

**Previsé™**

**Technical Manual**

# **Bailey DCS Connections**

**June 2013**

Prepared by:



### Printed in Canada

This document is subject to continuous improvement, and as such is subject to change without notice. Feedback or inquiries regarding this document are welcome. Contact Previsé via [www.previsé.com](http://www.previsé.com).

---

**Proprietary Notice:** This document and related software contain proprietary information which represents trade secrets of Previsé Inc.® and may not be copied or disclosed, except as provided in the license with Previsé Inc. Use of the information in this document and related software, for the reverse engineering of OPsCon,™ or for the development or manufacture of similar software is prohibited. The information in this document is subject to change without notice and should not be construed as a commitment by Previsé Inc. Previsé Inc. assumes no responsibility for any errors that may be in this document.

Copyright © 1999 - 2013 Previsé Inc.® All rights reserved.

Unauthorized reproduction is a violation of Previsé Inc. copyright.

### Trademarks

Previsé® is a trademark of Previsé Inc.®

iFIX™ and iHistorian are registered trademarks of GE Fanuc.

Bailey,® Network 90,® Net 90® and INFI 90® are registered trademarks of Elsasg Bailey Process Automation N.V.

Microsoft,® Windows NT,® and Microsoft SQL Server,™ are trademarks or registered trademarks of the Microsoft Corporation.

All other brand or product names are trademarks or registered trademarks of their respective holders.

### Notice

Previsé Inc.,® its partners, affiliates, employees, and agents, and the authors of, and contributors to, this publication and the software it represents, specifically disclaim all liabilities and warranties, express and implied (including warranties of merchantability and fitness for a particular purpose), for the accuracy, currency, completeness, and/or reliability of the information contained herein, and/or for the fitness for any particular use, and/or for the performance of any material, and/or for equipment selected in whole or part by the user in reliance upon information contained herein. Selection of materials and/or equipment is at the sole risk of the user of this publication.

# Table of Contents

<b>1</b>	<b>Introduction.....</b>	<b>1</b>
<b>2</b>	<b>Bailey DCS Overview .....</b>	<b>1</b>
<b>3</b>	<b>Supported Connections to Bailey DCS .....</b>	<b>2</b>
<b>4</b>	<b>CIC01 Connection .....</b>	<b>3</b>
<b>5</b>	<b>NCIU01 Connection .....</b>	<b>4</b>
<b>6</b>	<b>NCIU02 Connection .....</b>	<b>5</b>
<b>7</b>	<b>NCIU03 Connection .....</b>	<b>7</b>
<b>8</b>	<b>NCIU04 Connection .....</b>	<b>9</b>
<b>9</b>	<b>INICI01 / INICT01 Connection .....</b>	<b>11</b>
<b>10</b>	<b>INPCI02 Connection .....</b>	<b>13</b>
<b>11</b>	<b>IIMCP01 / IIMCP02 Connection .....</b>	<b>15</b>
<b>12</b>	<b>INICI03 / INICT03 Connection .....</b>	<b>19</b>
<b>13</b>	<b>INICI13 / INICT13 Connection .....</b>	<b>22</b>
<b>14</b>	<b>INICI12 / INICT12 Connection .....</b>	<b>25</b>

---

# Supported Bailey DCS Connections

---

## 1 Introduction

This manual provides technical information required for the physical connection of the Previs OPC Server/Driver to the Bailey® Net 90® or INFI 90® DCS.

This manual includes:

- Instructions for module set up for communications with Driver.
- Description of known communications limitations where applicable

This manual does not include:

- Instructions for installation or general configuration of modules.

### Previs OPC Server & Driver for Bailey DCS

Previs offers a Driver, which also functions as an OPC Server, for connection to Bailey DCS Systems. This product is sold in several different configurations, and this manual applies to all of them. In this manual, this Previs OPC Server/Driver is simply referred to as the **Driver**.

---

## 2 Bailey DCS Overview

The Net 90 DCS and the INFI 90 DCS are products of Elsas Bailey Process Automation N.V., now ABB, and are marketed and installed worldwide.

### Net 90 and INFI 90

The Net 90 DCS, introduced in the 1980, and the INFI 90 DCS, introduced in the 1988, are widely used for process control in process oriented plants, in industries such as pulp and paper, power generation, cement making, glass, chemical and many others. In these industries the Bailey DCS system are respected for the high level of process automation reliability that they bring.

### Data Highways

All DCS systems on the marketplace rely on a “data highway” for high speed data communications between all of the distributed components of the DCS system. Over the life of the Net 90 and INFI 90 product lines, three primary data highways have been used: Plant Loop™, Super Loop™ and INFI Net™.

### Connecting to Bailey DCS

The Driver may be connected to any Bailey DCS via a gateway device, variously called a Computer Interface Unit (CIU), an INFI-NET to Computer Interface (ICI) or a Plant Loop to Computer Interface (PCI). These interfaces, designed for connection of external devices to the Bailey DCS, allow the OPC Data Server to communicate with the Bailey DCS modules.

### 3 Supported Connections to Bailey DCS

The table below lists all of the Bailey DCS connections that are supported by the Driver. Further details regarding each of the supported connections may be found in the following sections within this appendix.

Support for communications to additional devices may be added. If you need support for devices not mentioned here, please contact us.

Supported Bailey DCS Connections							
Connection Method	Bailey DCS		Data Highway			Support	Ref. Section
	Net 90	INFI 90	Plant Loop	Super Loop	INFI Net		
CIC01 <sup>1</sup>						YES	4
NCIU01	X		X			YES <sup>2</sup>	5
NCIU02	X		X			YES	6
NCIU03	X		X			YES	7
NCIU04	X	X		X	X	YES	8
INICI01/INICT01		X		X	X	YES	9
INPCI02		X	X			YES	10
INMCP01	X	X	X	X	X	YES	11
INMCP02		X		X	X	YES <sup>3</sup>	11
INICI03/INICT03		X			X	YES <sup>4</sup>	12
INICI13/INICT13		X			X	YES	13
INICI12/INICT12	X	X	X	X	X	YES	14
INPCI01		X	X			YES <sup>5</sup>	-
IMCPM01/02/03						NO	

<sup>1</sup> This Loop Command Series product provides a connection to Bailey Module Bus rather than to data highway

<sup>2</sup> CIU01 data acquisition functions are supported. There are limitations for STATION type tags.

<sup>3</sup> INMCP02 support includes serial & SCSI communications. Previsc SCSI hardware kit required for SCSI communications.

<sup>4</sup> INICI03/INICT03 support includes serial & SCSI communications. Previsc SCSI hardware kit required for SCSI communications. Section 13 provides details of supported firmware versions.

<sup>5</sup> INPCI01 communications have not been tested, but we believe all required support is present. If INPCI01 communications are required, please call for assistance.

## 4 CIC01 Connection

### Overview

Overview Details of CIC01 Module	
<b>Supported Connections</b>	Supports connection to Plant Loop in Bailey Network 90 DCS.
<b>Maximum Point Capacity</b>	CIC01 supports to 500 Bailey Tags maximum. Driver supports 30,000 Tags and can support simultaneous multiple CIC01 connections.
<b>Bailey Document References</b>	Bailey Instruction Manual E92-504-2

### Module Overview

The CIC01 is a standalone communications module. It serves as an inexpensive communications link between the Driver and the Module Bus within the Bailey DCS.

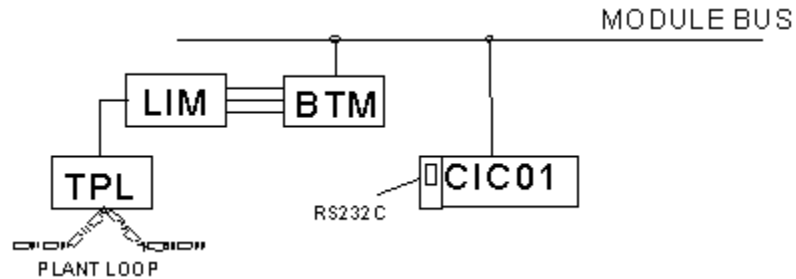

### Cabling to CIC01

The Driver is connected to the CIC01 using a serial RS-232 communication channel. Cables are not provided. Connect the serial RS-232 cable to the 9 pin D RS-232 connector. The wiring of the connector is defined in the CIC01 instruction manual E92-504-2. Connect the serial cable to the selected COM port of the computer containing the Driver.

### CIC01 Switch Settings

CIC01 Switch Settings		
<b>Switch Settings for CIC01</b>	S1-1 - Closed	Enables checksum of command reply
	S1-2 - Open	Selects 9600 baud, the maximum rate available with CIC01
	S1-3 - Open	
	S1-4 - Closed	Selects 8 data bits, 1 stop bit, no parity
	S1-5 - Closed	
	S1-6	n/a
	S1-7	
	S1-8	Open selects module address of 1; Closed selects default address of 0

## 5 NCIU01 Connection

The Driver supports all data acquisition functions of the NCIU01, but has limitations with respect to STATION tag types. Please call for details.

### Overview

NCIU01 Overview	
<b>Supported Connections</b>	Supports connection to Plant Loop in Bailey Network 90 DCS.
<b>Maximum Point Capacity</b>	NCIU01 supports to 511 Bailey tags. Driver supports to 30,000 tags and can support multiple simultaneous NCIU01 connections

### Module Structure

The NCIU01 consists of the following three modules:

- NLIM02 (Loop Interface Module - LIM)
- NPTM01 (Point Table Module - PTM)
- NSIM01 (Serial Interface Module - SIM).

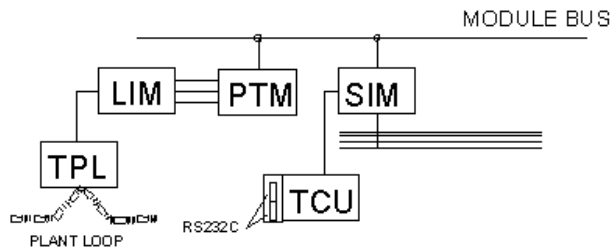

The LIM, PTM and SIM modules reside in a dedicated module mounting unit chassis (MMU). The PTM is connected to the LIM via a direct-memory-access ribbon cable. The PTM stores data then transfers it to the SIM for sending to the Driver. The three modules form a Plant Loop node.

The NSIM01 is connected to a NTCU01 termination unit that provides two RS232 serial ports. The Driver connects to one of these serial ports, communicating at a rate of up to 19,200 Baud.

### Cabling to NCIU01

The Driver is connected to the NCIU01 using a serial RS-232 communication channel. Cables are not provided. Connect the serial RS-232 cable to the 25 pin D connector labeled “Terminal”. The wiring of the connector is defined in the CIU driver’s instruction manual. At the computer containing the driver, connect the serial cable to the COM port.

### CIU01 Settings

NCIU01 Settings	
<b>Dip shunt Straps for TMF or IMF</b>	Note: 0=Cut (OPEN), 1=Intact (CLOSED) XU1 – 1110011010 XU2 – 0010100000

## 6 NCIU02 Connection

### Overview

NCIU02 Overview	
<b>Supported Connections</b>	Supports connection to Plant Loop in Bailey Network 90 DCS.
<b>Maximum Point Capacity</b>	NCIU02 supports to 2500 Bailey Tags. Driver supports to 30,000 Tags
<b>Bailey Document References</b>	Bailey Instruction Manual E93-905-9 Enhanced Computer Interface Unit Programmer's Reference Manual INFI-Net Communications Modules E96-601 Bailey Instruction Manual E93-905-2.

### Module Structure

The NCIU02 consists of following three modules:

- NLIM02 (Loop Interface Module)
- NBTM01 (Bus Transfer Module)
- NLSM01 (Loop Storage Module)

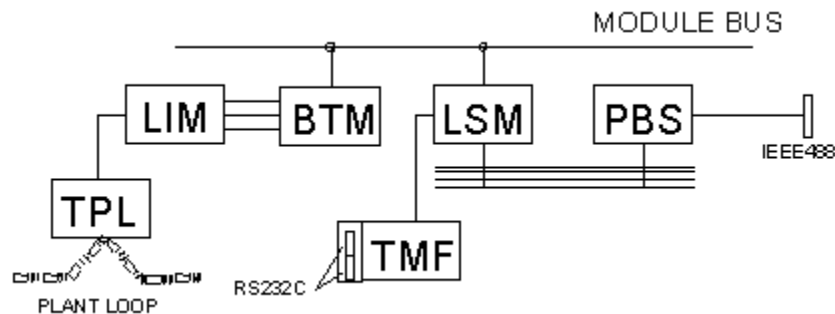

The BTM is connected to the LIM with a direct-memory-access ribbon cable. The two modules work together as one. The BTM transfers data from the Plant Loop to the LSM where it is held until required by the Driver. The three modules form a node on the Plant Loop.

The NLSM01 is connected to a NTMF01 termination unit that provides two RS232 serial ports. The Driver connects to one of these serial ports, communicating at 19,200 Baud.

### IEEE488 Parallel Bus

The NCIU02 can optionally contain an NPBS01 (Parallel Bus Slave module). This module takes a single slot. The PBS provides an IEEE-488 parallel bus for communication with the loop storage module. The module can transfer bursts of data over the IEEE-488 bus at 240K bytes/second. The communication transfer rate to the LSM is limited to 80,000 bytes/second by the expander bus capability. The Driver does not support IEEE-488 communications.

## Cabling to NCIU02

The Driver is connected to the NCIU02 using a serial RS-232 communication channel. The required cables are not provided.

### At the NCIU02:

Connect the serial RS-232 cable to the 25 pin D connector labeled “Terminal”. The wiring of the connector is defined in the CIU driver’s instruction manual.

### At the Driver:

Connect the serial cable to the selected COM port.

## NCIU02 Settings

NCIU02 Settings	
<b>DIP Switch Settings for LSM</b>	Note: 0=Closed (ON), 1=Open(OFF) U72 – 00010010 U73 – 11111111 U75 – 00000
<b>DIP Switch Settings for LIM</b>	Note: 0=Closed (ON), 1=Open(OFF) SW1 – 00110000 SW2 – Bailey Node Address
<b>DIP Switch Settings for BTM</b>	Note: 0=Closed (ON), 1=Open(OFF) SW1 - 00000
<b>Dip shunt Straps for TMF or IMF</b>	Note: 0=Cut (OPEN), 1=Intact (CLOSED) XU1 – 1110011010 XU2 – 0010100000

## 7 NCIU03 Connection

### Overview

NCIU03 Overview	
<b>Supported Connections</b>	Supports connection to Plant Loop in Bailey Network 90 DCS.
<b>Maximum Point Capacity</b>	NCIU03 supports to 5,000 Tags. Driver can support to 30,000 Tags
<b>Bailey Document References</b>	Bailey Instruction Manual E93-905-9: Enhanced Computer Interface Unit Programmer's Reference Manual Bailey Instruction Manual E93-905-2.

### Module Structure

The NCIU03 consists of the following three modules:

- NLIM02 (Loop Interface Module)
- NBTM01 (Bus Transfer Module)
- NLSM02 (Loop Storage Module).

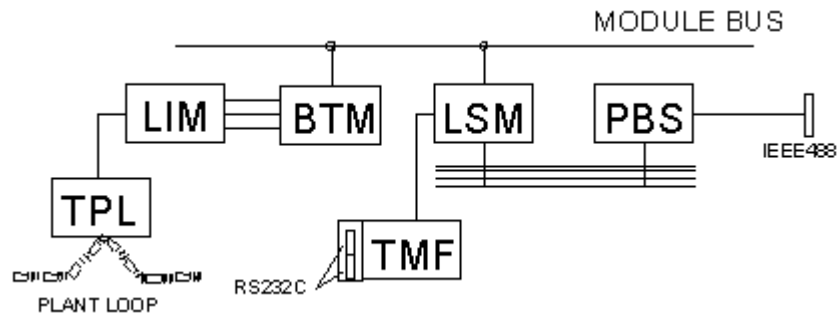

The BTM is connected to the LIM via a direct-memory-access ribbon cable. The two modules work together as one. The BTM transfers data from the Plant Loop to the LSM where it is held until required by the Driver node. The three modules form a node on the Plant Loop. Figure 4 illustrates the structure of the NCIU03.

The NLSM02 is connected to a NTMF01 termination unit that provides two RS232 serial ports.

### Optional IEEE488 Parallel Bus

The NCIU03 can optionally contain an NPBS01 (Parallel Bus Slave module). This module takes a single slot. The PBS provides an IEEE-488 parallel bus for communication with the loop storage module. The module can transfer bursts of data over the IEEE-488 bus at 240K bytes/second. The communication transfer rate to the LSM is limited to 80,000 bytes/second by the expander bus capability.

Driver does not support IEEE-488 communications..

## Cabling to NCIU03

The Driver is connected to the NCIU03 using a serial RS-232 communication channel. The required cables are not provided.

### At the NCIU03:

Connect the serial RS-232 cable to the 25 pin D connector labeled “Terminal”. The wiring of the connector is defined in the CIU driver’s instruction manual.

### At the Driver:

Connect the serial cable to the selected COM port.

## NCIU03 Setup

NCIU03 Setup	
<b>DIP Switch Settings for LSM</b>	Note: 0=Closed (ON), 1=Open(OFF) U72 – 00010010 U73 – 11111111 U75 – 00000
<b>DIP Switch Settings for LIM</b>	Note: 0=Closed (ON), 1=Open(OFF) SW1 – 00110000 SW2 – Bailey Node Address
<b>DIP Switch Settings for BTM</b>	Note: 0=Closed (ON), 1=Open(OFF) SW1 – 00000
<b>Dip shunt Straps for TMF or IMF</b>	Note: 0=Cut (OPEN), 1=Intact (CLOSED) XU1 – 1110011010 XU2 – 0010100000

## 8 NCIU04 Connection

### Overview

NCIU04 Overview	
<b>Supported Connections</b>	Supports connection to the Super Loop in Bailey Network 90 DCS.
<b>Maximum Tag Capacity</b>	NCIU04 supports to 10,000 tags. Driver supports up to 30,000 tags
<b>Bailey Document References</b>	Bailey Instruction Manual E93-905-9: Enhanced Computer Interface Unit Programmer's Reference Manual INFI-Net to Plant Loop Gateway (INIPL01) manual E96-602

### Module Structure

The NCIU04 is based on the Network 90 architecture. It uses the module bus for back plane communication. It consists of the following two modules:

- NLIS01 (Loop Interface Slave module)
- NSSM01 (Super Loop Storage Module)

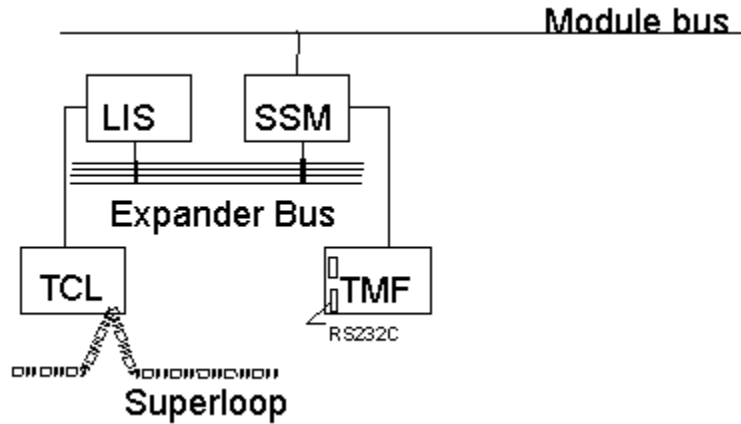

The NSSM01 occupies two slots. The NLIS01 is a slave module to the NSSM01, which acts as a bus master module. The SSM module communicates to the LIS module over the expander bus. These two modules form a Super Loop node.

The NSSM01 is connected to a NTMF01 termination unit that provides two RS232 serial ports. Driver connects to one of these serial ports, communicating at 19,200 Baud.

## Cabling to NCIU04

The Driver is connected to the NCIU04 using a serial RS-232 communication channel. The required cables are not provided.

### At the NCIU04:

Connect the serial RS-232 cable to the 25 pin D connector labeled “Terminal.” The wiring of the connector is defined in the CIU driver’s instruction manual.

### At the Driver:

Connect the serial cable to the selected COM port.

## NCIU04 Setup

<b>NCIU04 Setup</b>	
<b>DIP Switch Settings for SSM</b>	Note: 0=Closed (ON), 1=Open(OFF) U72 – 00010010 U73 – 11111111 U75 – 00000
<b>DIP Switch Settings for LIS</b>	Note: 0=Closed (ON), 1=Open(OFF) SW1 – Bailey Loop Address SW2 – Bailey Node Address SW3 – 01001000 (Set for 10MB Super Loop) SW4 – 00010000 Jumper Settings per Silk Screen on Module
<b>Dip shunt Straps for TMF or IMF</b>	Note: 0=Cut (OPEN), 1=Intact (CLOSED) XU1 – 1110011010 XU2 – 0010100000

## 9 INICI01 / INICT01 Connection

### Overview

INICI01 Overview	
<b>Supported Connections</b>	INFI-Net and the Super Loop in Bailey INFI 90 DCS.
<b>Maximum Tag Capacity</b>	ICI01 supports to 10,000 tags. Driver can support to 30,000 tags
<b>Bailey Document References</b>	Bailey Instruction Manual E93-905-9: Enhanced Computer Interface Unit Programmer's Reference Manual Manual E96-501D. Manual E96-610A.

### Module Structure

The ICI01 replaces the NCIU04 for communications to the Super Loop in an INFI-90 DCS system. The ICI01 consists of the following two modules:

- NNIS01 (Network Interface Slave module)
- INICT01 (INFI-NET to Computer Transfer module)

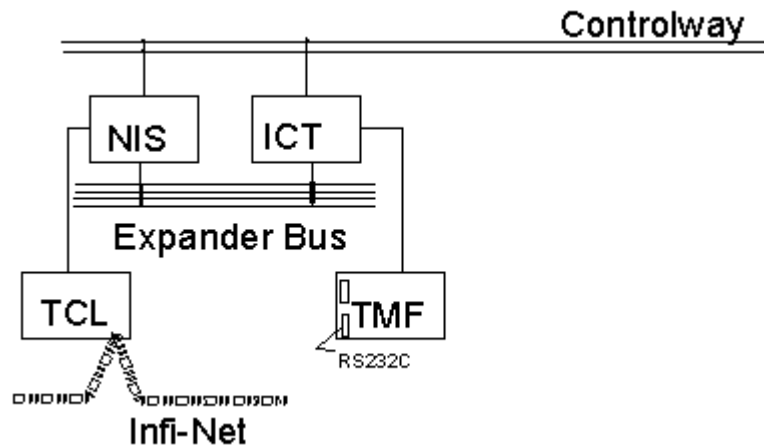

The INICT01 occupies two slots. The INNIS01 is a slave to the INICT01, which acts as a bus master module. The ICT module communicates to the NIS module over the expander bus. These two modules form an Infi-Net node.

The INICT01 is connected to a NTMF01 termination unit. This termination unit provides the physical wiring connections that allow the Driver to be connected to the INICT01 master module. The NTMF01 provides two RS232C serial ports for communication to the INICT01 module. The Driver uses one of these serial ports, communicating at 19,200 Baud.

## Cabling to ICI01

The Driver is connected to the ICI01 using a serial RS-232 communication channel. The required cables are not provided.

### At the ICI01:

Connect the serial RS-232 cable to the 25 pin D connector labeled “Terminal”. The wiring of the connector is defined in the CIU instruction manual.

### At the Driver:

Connect the serial cable to the selected COM port.

## INICI01 Component Setup

INICI01 Component Setup	
<b>DIP Switch Settings for ICT01</b>	Note: 0=Closed (ON), 1=Open(OFF) U72 – 00010010 U73 – 11111111 U75 – 00000
<b>DIP Switch Settings for NIS01</b>	Note: 0=Closed (ON), 1=Open(OFF) SW1 – Bailey Loop Address SW2 – Bailey Node Address SW3 – 01001000 (Set for 10MB Super Loop) SW4 – 00010000 Jumper Settings per Silk Screen on Module
<b>Dip shunt Straps for TMF or IMF</b>	Note: 0=Cut (OPEN), 1=Intact (CLOSED) XU1 – 1110011010 XU2 – 0010100000

## 10 INPCI02 Connection

### Overview

INPCI02 Overview	
<b>Supported Connections</b>	Plant Loop in Bailey Net 90 DCS.
<b>Maximum Tag Capacity</b>	INPCI02 supports to 5,000 tags. Driver support to 30,000 Tags
<b>Bailey Document References</b>	Bailey Instruction Manual E93-905-9: Enhanced Computer Interface Unit Programmer's Reference Manual Manual E96-501D. Manual E96-610A.
<b>Controller Modules Supported</b>	Driver supports Function Code data communications to the following controller modules: MFP01; MFP02; MFP03; MFC01; MFC02; MFC03; MFC04; MFC05 ;COM01; COM 02; COM03; COM04; LMM01; LMM02; RIO01; RIO02

### Module Structure

The INPCI02 consists of three modules:

- INLIM03 (Loop Interface Module)
- INBTM01 (Bus Transfer Module)
- INPCT01 (Plant Loop to Computer Transfer module)

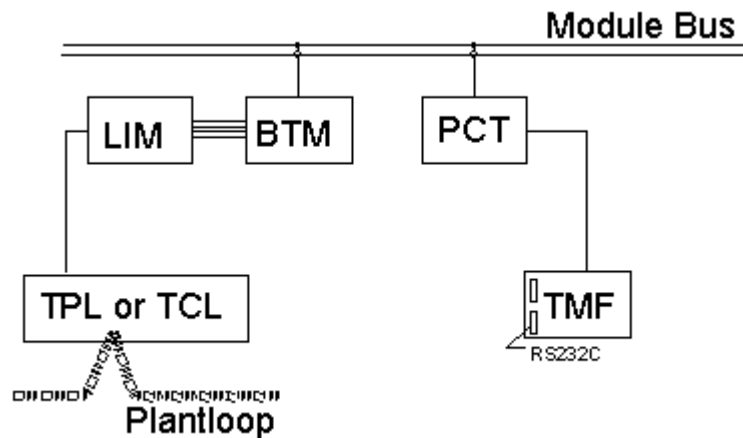

The bus transfer module communicates with the loop interface module through a direct memory access ribbon cable. The bus transfer module transfers the data from the plant loop to the computer transfer module. The computer transfer module responds to commands from the Driver and delivers the data requested.

The PCT provides two RS232C communication channels for communication. These channels are similar to those provided by its predecessor, the CIU.

## Cabling to INPCI02

The Driver is connected to the INPCI02 using a serial RS-232 communication channel. The required cables are not provided.

### At the INPCI02:

Connect the serial RS-232 cable to the 25 pin D connector labeled “Terminal”. The wiring of the connector is defined in the CIU driver’s instruction manual.

### At the Driver:

Connect the serial cable to the selected COM port.

## INPCI01 Setup

<b>INPCI02 Setup</b>	
<b>DIP Switch Settings for PCT</b>	Note: 0=Closed (ON), 1=Open(OFF) U72 – 00010010 U73 – 11111111 U75 – 00000
<b>DIP Switch Settings for LIM</b>	Note: 0=Closed (ON), 1=Open(OFF) SW1 – 00110000 SW2 – Bailey Node Address
<b>DIP Switch Settings for BTM</b>	Note: 0=Closed (ON), 1=Open(OFF) SW1 - 00000
<b>Dip shunt Straps for TMF or IMF</b>	Note: 0=Cut (OPEN), 1=Intact (CLOSED) XU1 – 1110011010 XU2 – 0010100000

## 11 IIMCP01 / IIMCP02 Connection

### Overview

IIMCP01/02 Overview	
<b>Supported Connections</b>	IIMCP01: Plant Loop IIMCP02: INFI-Net and the Super Loop in INFI 90
<b>Maximum Point Capacity</b>	IIMCP01/02 supports to 10,000/30,000 tags. Driver supports to 30,000 tags
<b>Bailey Document References</b>	Bailey Instruction Manual E93-905-9: Enhanced Computer Interface Unit Programmer's Reference Manual
	Manual E96-501D.
	Manual E96-610A. Operator Interface Station (40 Series) Hardware manual

### Module Structure

The CIU type interface consists of three modules:

- IIMLM01 multi-bus loop module
- IIMCP01/02 multi-bus communication processor module
- IIMCL01 loop termination module

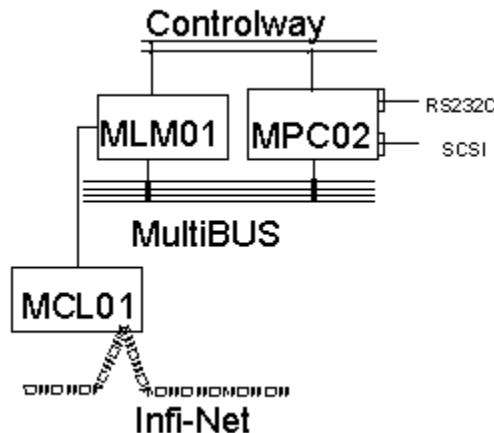

The IIMLM01 multi-bus loop module, allows communication between the multi-bus communication processor module (IIMCP01 or IIMCP02) and the INFI-NET or Plant Loop communication highway through the termination module (IIMCL01).

Two ribbon cables connect the loop module to the communication processor module and to the communication loop module terminations. Dipswitches SW1 and SW2 select the node address and ring number of the console.

An IIMKM02 keyboard interface or an IIMRM02 reset module is present in the multi-bus card cage. The modules provide power-up reset signal and power fault interrupt on the multi-bus back-plane.

## Cabling for Serial Communications (IIMCP01 & IIMCP02)

The Driver is connected to the IIMCP02 via serial RS-232.

### At the IIMCP01/02:

For serial connect the RS-232 cable to the 9 pin D connector labeled PORT-B. Standard 9 pin RS232 cables can be used (not provided). IIMCP01/02 DIP switch settings must be correct.

### At the Driver:

Connect the serial cable to the selected COM port.

## Cabling for SCSI Communications (IIMCP02)

A **SCSI Connection Kit** containing the required cables, certified SCSI interface adapter and terminators must be purchased from Previsé (or your supplier). This kit contains:

- a) SCSI Adapter for connect to PC computer<sup>6</sup>
- b) SCSI connector to connect to IIMCP02/INICT03 SCSI connector
- c) All cables & connectors required to connect between (a) and (b) above<sup>7</sup>
- d) Appropriate SCSI termination hardware<sup>8</sup>
- e) Installation instructions



***NOTE: The SCSI standard employed is an old 8 bit SCSI-1 standard. Maintenance of warranty requires purchase of SCSI kit mentioned above.***

### At the IIMCP02:

Connect the standard 50 pin flat cable connector to IIMCP02 connector P7. Appropriate SCSI termination hardware, provided in the kit, must be installed according to the accompanying instructions.

### At the Driver:

Install the provided SCSI adapter and connect the SCSI cable provided in the kit to the connector on the SCSI adapter.



***NOTE: The SCSI channel used for DCS communications must be a dedicated SCSI channel with no other devices on the same SCSI Adapter.***

<sup>6</sup> Previsé offers a SCSI Adapter kit suitable for installation in a 5 volt PCI card slot. It is expected that additional options will be required for installation in 3.5 volt PCIX card slot and via USB port. Contact us if you require this.

<sup>7</sup> The recommended SCSI cable length is limited to 6 feet (1.8 meters).

<sup>8</sup> SCSI termination will include one or more of (a) SCSI terminator connector to install in connector P8, or (b) SIP resistors may need to be inserted in IIMCP02 connectors labeled RN2, RN3 and RN4 or (c) SCSI cable may have a build in terminator.

## IIMCP01 Setup

<b>IIMLM01 DIP Switch Description</b>			
<b>Switch</b>	<b>Position</b>	<b>Description</b>	<b>Switch Settings / Range</b>
1	1-8	Node / PCU	1 - FA (hex pole 8 LSB)
2	1-8	Ring / Loop	1 - FA (hex pole 8 LSB)
3	1	Device Compatibility	<b>0 = MCP</b>
			1 = BCM
	2	ROM checksum	0 = No checksum
			<b>1 = Checksum Enabled</b>
	3	RUN mode	<b>0 = Normal Operation</b>
			1 = Test mode
	4	Busy Test	<b>0 = Normal Operations</b>
			1 = Busy NAK all loop messages if RUN mode is Test
5	Broken Loop Indication	0 = Disable LED's flashing	
		<b>1 = Flashing LED's</b>	
6	Diagnostic Enabled	<b>0 = Normal Operations</b>	
		1 = Diagnostic enabled	
7-8	Loop Type	00 = 10 MHz INFI-NET	
		01 = 2 MHz INFI-NET	
		10 = Do not use	
		11 = Plant Loop	
4	1-3	I/O expander bus address select	0 – 7
	4-8	LED display select	0 – 1F (hex)

**NOTE: 0 = CLOSED or ON, 1 = OPEN or OFF. Bold areas indicate factory default settings.**

Use factory settings, or settings to match DCS configuration, to set up IIMLM01.

<b>IIMCP01 DIP Switch Description</b>			
<b>Switch</b>	<b>Position</b>	<b>Description</b>	<b>Switch Settings / Range</b>
Configure the IIMCP01 module by setting dipswitches. Also located on the module board are jumpers J5, J6, and J7. Jumper J5 should not be changed from the factory setting.			
0	1	ROM checksum	0 = No checksum
			<b>1 = Checksum Enabled</b>
	2-3	Port A Parity settings	00 = 8 d, 1s, no parity
			01 = 8 d, 1s, even parity
			<b>10 = 8 d, 1s, odd parity</b>
			11 = 8 d, 1s, no parity
4	Port B Mode	0 = NIU command mode	
		<b>1 = NIU utility mode</b>	
5-6	Port B Parity settings	00 = 8 d, 1s, no parity	
		01 = 8 d, 1s, even parity	
		<b>10 = 8 d, 1s, odd parity</b>	
		11 = 8 d, 1s, no parity	
7	Command checksum	0 = No checksum	
		<b>1 = Checksum Enabled</b>	
1	1-4	Port A baud rate	<b>1111 = 19200</b> , 0111 = 9600
	5-8	Port B baud rate	1111 = 19200, <b>0111 = 9600</b>
2	1	Firmware test mode	0 = Test mode
			<b>1 = Normal Operation</b>
	2	Diagnostic mode	<b>0 = Disabled</b>
			1 = enabled
	3	INFI-NET system diagnostic mode	<b>0 = Disabled</b>
			1 = enabled
4-6	Not used	-	
7	NVRAM	<b>1 = enabled</b> , 0 = disabled	
8	RAM Size	<b>1, 0</b>	

**NOTE: 0 = CLOSED or ON, 1 = OPEN or OFF. Bold areas indicate factory default settings.**

<b>IIMCP02 DIP Switch Description</b>			
<b>Switch</b>	<b>Position</b>	<b>Description</b>	<b>Switch Settings / Range</b>
1	1-4	Port A baud rate	<b>1111 = 19200</b> , 0111 = 9600
	5-8	Port B baud rate	1111 = 19200, <b>0111 = 9600</b>
2	1	MLM handshake timeout	<b>0 = Enabled</b> 1 = Disabled
	2	MLM Diagnostic mode	<b>0 = Disabled</b> 1 = Enabled
	3	Diagnostic utilities mode	<b>0 = Disabled</b> 1 = Enabled
	4	Hardware diagnostics	<b>0 = Disabled</b> 1 = Enabled
	5-8	Not used	-
3	1	SCSI port	0 = Disabled <b>1 = Enabled</b>
	2-4	SCSI address	<b>100 = 4</b>
	5	SCSI parity check enabled	0 = Disabled <b>1 = Enabled</b>
	6-8	Not used	-
4	1	ROM checksum	<b>0 = Enabled</b> 1 = Disabled
			Serial Port Parity settings
	4	Serial Port B Mode	0 = NIU command mode <b>1 = NIU utility mode</b>
	5	Modem Password protection	<b>0 = Disabled</b> 1 = enabled
	6	Port addressing mode	<b>0 = Disabled</b> 1 = enabled
	7	Command checksum	0 = Disabled <b>1 = Enabled</b>
	8	Security ENABLE MCP02 only	1 = Security Enabled 0 = Security Disabled
<b>NOTE: 0 = CLOSED or ON, 1 = OPEN or OFF. Bold areas indicate factory default settings.</b>			

<b>IIMCP02 Default Jumper Settings</b>						
<b>J1</b>	<b>J2</b>	<b>J5,J6</b>	<b>J7</b>	<b>J8</b>	<b>J9</b>	<b>J10,J11</b>
1-3	1-4	1-2	1-2	1-2	3-4	1-2
2-4			3-4			
5-7			5-6			
6-8			7-8			
<b>Default jumper settings should not be changed for standard applications.</b>						

<b>IIMCP01 DIP Switch Settings for Serial Communications</b>	
<b>DIP Switch 0</b>	LSB 1101xx1x MSB
<b>DIP Switch 1</b>	LSB 1111xxxx MSB
<b>DIP Switch 2</b>	LSB 100xxx11 MSB

<b>IIMCP02 DIP Switch Settings for Serial Communications</b>	
<b>DIP Switch 1</b>	LSB 11111111 MSB
<b>DIP Switch 2</b>	LSB 00000000 MSB
<b>DIP Switch 3</b>	LSB 01000000 MSB
<b>DIP Switch 4</b>	LSB 00000010 MSB

<b>IIMCP02 DIP Switch Settings for SCSI Communications</b>	
<b>DIP Switch 1</b>	LSB 11111111 MSB
<b>DIP Switch 2</b>	LSB 00000000 MSB
<b>DIP Switch 3</b>	LSB 11001000 MSB
<b>DIP Switch 4</b>	LSB 00010010 MSB

## 12 INICI03 / INICT03 Connection

### Overview

INICI03 / INICT03 Overview	
<b>Supported Connections</b>	INFI-Net and the Super Loop in Bailey INFI 90 DCS.
<b>Maximum Tag Capacity</b>	INICI03 supports to 30,000 tags. Driver supports to 30,000 tags
<b>Bailey Document References</b>	Bailey Instruction Manual E93-905-9: Enhanced Computer Interface Unit Programmer's Reference Manual Manual E96-501D. Manual E96-610A.

### Module Structure

The ICI03 consists of the following modules:

- INNIS01 (Network Interface Slave module)
- INICT03 (INFI-NET to Computer Transfer module)
- IMMPI01 – SCSI and serial interface
- NKTU01 cable
- NTPM01 terminator

The INICT03 occupies two slots. The INNIS01 is a slave to the INICT03, which acts as a bus master module. The ICT03 communicates to the NIS over the expander bus. These two modules form a node on the INFI-NET.

The INICT03 is connected to a NTPM01 termination unit. This termination unit provides the physical wiring connections that allow the Driver to be connected to the INICT03 master module. The NTPM01 provides two RS232C serial ports for communication to the INICT03 module. The Driver can use one of these serial ports, communicating at 19,200 Baud.

The INICT03 is designed with a SCSI interface. This interface is the preferred connection to the host computer and should be used in most applications.

### Cabling for Serial Communications to INICT03

#### At the INICT03:

Connect the serial RS-232 cable to the 25 pin D connector labeled "Printer". The wiring of the connector is defined in the CIU driver's instruction manual.

#### At the Driver:

Connect the serial cable to the selected COM port.

## Cabling for SCSI Communications to INICT03

A **SCSI Connection Kit** containing the required cables and certified SCSI interface adapter must be purchased from Previsé (or your supplier). This kit contains:

- SCSI Adapter for connect to PC computer (PCI or PCI-X or PCI Express card slot)<sup>9</sup>
- Cable required to connect between SCSI adapter and INICI03<sup>10</sup>
- Installation instructions



**NOTE:** *The SCSI standard employed is an old 8 bit SCSI-1 standard. Maintenance of warranty requires purchase of SCSI kit mentioned above.*

### At the INICT03:

Connect the standard 50 pin flat cable connector to IMMPI01. Appropriate SCSI termination hardware, provided in the kit, must be installed according to the accompanying instructions.

### At the Driver:

Install the provided SCSI adapter and connect the SCSI cable provided within the SCSI kit to the connector on the SCSI adapter.



**NOTE:** *The SCSI channel used for DCS communications must be a dedicated SCSI channel with no other devices on the same SCSI Adapter.*

## NIS and TMF Setup

Configure INNIS01 per instructions in ABB Instruction Manual. Must be configured correctly for your specific DCS configuration.

## INICT03 Firmware Version Considerations

There is a set of versioned EPROM firmware installed on the INICT03. Driver support for this firmware is as follows:

Firmware Version	Supported?
Versions prior to E0	Supported
E0	Supported
F0, F1	Not Supported – Hardware dongle required.
G0 and later	Supported

<sup>9</sup> Previsé offers a SCSI Adapter kit, consisting of SCSI adapter card and SCSI cable. To order you must specify (a) whether the SCSI adapter card must insert into PCI or PCI-X or PCI Express card slot within the PC and (b) 6, 8, 10, pr 12 feet cable length. It is your responsibility to ensure this is correctly specified to Previsé.

<sup>10</sup> The SCSI cable length, between impedance termination at either end, MUST not exceed 6 meters (19 feet). Recommended SCSI cable length is 6, 8, 10 or 12 feet, provided that overall length between terminations < 6 meters maintained .

## INICT03 DIP Switch Description

<b>INICT03 DIP Switch Description</b>			
<b>Switch</b>	<b>Position</b>	<b>Description</b>	<b>Switch Settings / Range</b>
1	1-4	Port A baud rate	<b>1111 = 19200</b> , 0111 = 9600
	5-8	Port B baud rate	1111 = 19200, <b>0111 = 9600</b>
2	1	MLM handshake timeout	<b>0 = Enabled</b> 1 = Disabled
	2	MLM Diagnostic mode	<b>0 = Disabled</b> 1 = Enabled
	3	Diagnostic utilities mode	<b>0 = Disabled</b> 1 = Enabled
	4	Hardware diagnostics	<b>0 = Disabled</b> 1 = Enabled
	5-7	Not used	-
3	1	SCSI port	0 = Disabled <b>1 = Enabled</b>
	2-4	SCSI address	<b>100 = 4</b>
	5	SCSI parity check enabled	0 = Disabled <b>1 = Enabled</b>
	6-8	Not used	-
4	1	ROM checksum	<b>0 = Enabled</b> 1 = Disabled
			2-3
	4	Serial Port B Mode	0 = NIU command mode <b>1 = NIU utility mode</b>
	5	Modem Password protection	<b>0 = Disabled</b> 1 = enabled
	6	Port addressing mode	<b>0 = Disabled</b> 1 = enabled
	7	Command checksum	0 = Disabled <b>1 = Enabled</b>
	8	Security ENABLE MCP02 only	1 = Security Enabled <b>0 = Security Disabled</b>
<b>INICT03 DIP Switch Settings for Serial Communications</b>			
<b>DIP Switch 1</b>	LSB 11111111 MSB		
<b>DIP Switch 2</b>	LSB 00000000 MSB		
<b>DIP Switch 3</b>	LSB 01000000 MSB		
<b>DIP Switch 4</b>	LSB 00000010 MSB		
<b>INICT03 DIP Switch Settings for SCSI Communications</b>			
<b>DIP Switch 1</b>	LSB 11111111 MSB		
<b>DIP Switch 2</b>	LSB 00000000 MSB		
<b>DIP Switch 3</b>	LSB 11000000 MSB		
<b>DIP Switch 4</b>	LSB 00010010 MSB		
<b>NOTE: 0 = CLOSED or ON, 1 = OPEN or OFF. Bold areas indicate default settings.</b>			

## 13 INICI13 / INICT13 Connection

### Overview

INICI13 / INICT13 Overview	
<b>Supported Connections</b>	INFI-Net and the Super Loop in Bailey INFI 90 DCS.
<b>Maximum Tag Capacity</b>	INICI13 supports to 30,000 tags. Driver supports to 30,000 tags
<b>Bailey Document References</b>	ABB Instruction Manual 3BUA000354R0001 Harmony Series Cnet-to-Computer Communication Interface INICI03

### Module Structure

The ICI13 consists of the following modules:

- INNIS21 (Network Interface Slave module)
- INICT13 (INFI-NET to Computer Transfer module)
- P-HC-BRC-PBA20000 Symphony Processor Bus Adapter
- NKTU01 cable
- NTPM01 terminator.

The INICT13 occupies one slot. The INNIS21 is a slave to the INICT13, which acts as a bus master module. The ICT13 communicates to the NIS over the expander bus. These two modules form a node on the INFI-NET.

The INICT13 is connected to a NTPM01 termination unit. This termination unit provides the physical wiring connections that allow the Driver to be connected to the INICT13 master module. The NTPM01 provides two RS232C serial ports for communication to the INICT13 module. The Driver can use one of these serial ports, communicating at 19,200 Baud.

The INICT13 is designed with a SCSI interface. This interface is the preferred connection to the host computer and should be used in most applications.

### Cabling for Serial Communications to INICT13

#### At the INICT13:

Connect the serial RS-232 cable to the 25 pin D connector labeled “Printer”. The wiring of the connector is defined in the CIU driver’s instruction manual.

#### At the Driver:

Connect the serial cable to the selected COM port.

## Cabling for SCSI Communications to INICT13

A **SCSI Connection Kit** containing the required cables and certified SCSI interface adapter must be purchased from Previsé (or your supplier). This kit contains:

- SCSI Adapter for connect to PC computer (PCI or PCIX card slot)<sup>11</sup>
- Cable required to connect between SCSI adapter and INICI13<sup>12</sup>
- Installation instructions



***NOTE: The SCSI standard employed is an old 8 bit SCSI-1 standard. Maintenance of warranty requires purchase of SCSI kit mentioned above.***

---

### At the INICT13:

Connect the standard 50 pin flat cable connector to INICT13. Appropriate SCSI termination hardware, provided in the kit, must be installed according to the accompanying instructions.

### At the Driver:

Install the provided SCSI adapter and connect the SCSI cable provided within the SCSI kit to the connector on the SCSI adapter.



***NOTE: The SCSI channel used for DCS communications must be a dedicated SCSI channel with no other devices on the same SCSI Adapter.***

---

## INNIS21 Setup

Configure INNIS21 per instructions in ABB Instruction Manual 3BUA000354R00O1 - Harmony Series - Cnet-to-Computer Communication Interface INICI03. Must be configured correctly for your specific DCS configuration.

---

<sup>11</sup> Previsé offers a SCSI Adapter kit, consisting of SCSI adapter card and SCSI cable. To order you must specify (a) whether the SCSI adapter card must insert into PCI or PCI-X or PCI Express card slot within the PC and (b) 6, 8, 10, or 12 feet cable length. It is your responsibility to ensure this is correctly specified to Previsé.

<sup>12</sup> The SCSI cable length, between impedance termination at either end, MUST not exceed 6 meters (19 feet). Recommended SCSI cable length is 6, 8, 10 or 12 feet, provided that overall length between terminations < 6 meters maintained .

## INICT13 DIP Switch Description

<b>INICT13 DIP Switch Description</b>			
<b>Switch</b>	<b>Pole</b>	<b>Description</b>	<b>Switch Settings / Range</b>
SW2 RS232 Speed	1-4	Port 0 baud rate	1111 = 19200, 0111 = 9600
	5-8	Port 1 baud rate	1111 = 19200, 0111 = 9600
SW3 Diagnostics	1	Emulator Running in RAM	0 = Disabled 1 = Enabled
	2	ROM checksumming	0 = Enabled 1 = Disabled
	3	INNIS21 handshake timeout	0 = Enabled – Normal Operation 1 = Disabled
	4	INNIS module diagnostics	0 = Disabled – Normal operation 1 = Enabled
	5	Cnet/Infi-Net diagnostics	0 = Disabled – Normal operation 1 = Enabled
	6-8	Not used	-
	SW4	1	SCSI port
2-4		SCSI address <sup>13</sup>	0/0/0 = 0; 0/0/1 = 1; 0/1/0 = 2; 0/1/1 = 3; 1/0/0 = 4; 1/0/1 = 5; 1/1/0 = 6; 1/1/1 = 7;
5		SCSI parity check enabled	0 = Disabled 1 = Enabled
6-8		Cache Mode	0/0/0 = Disabled; 0/0/1 = Instruction; 0/1/0 = Data; 0/1/1 = Data, Instruction 1/0/0 = Branch; 1/0/1 = Branch, Instruction 1/1/0 = Branch, Data 1/1/1 = Branch, Data, Instruction
SW5	1	Hardware diagnostics	0 = Disabled 1 = Enabled
	2-3	Serial Port Parity settings (ports 0 and 1)	00 = 8 d, 1s, no parity 01 = 8 d, 1s, even parity 10 = 8 d, 1s, odd parity 11 = 8 d, 2s, no parity
	4	Serial Port 1 Mode	0 = Serial Port to Host computer 1 = Utility operation
	5	Modem Password protection	0 = Disabled 1 = enabled
	6	Port addressing mode	0 = Disabled 1 = enabled
	7	Checksumming Option	0 = Disabled 1 = Enabled
	8	Security	1 = Enabled (Port 1 key required) 0 = Disabled (Port 1 is 2nd command port)
<b>INICT13 Switch Settings for Serial Communications</b>			
<b>Switch SW2</b>		LSB 11111111 MSB	
<b>Switch SW3</b>		LSB 01000xxx MSB	
<b>Switch SW4</b>		LSB 0100x111 MSB	
<b>Switch SW5</b>		LSB 00000010 MSB	
<b>INICT13 Switch Settings for SCSI Communications</b>			
<b>Switch SW2</b>		LSB 11111111 MSB	
<b>Switch SW3</b>		LSB 01000xxx MSB	
<b>Switch SW4</b>		LSB 11000111 MSB	
<b>Switch SW5</b>		LSB 00010010 MSB	
<b>NOTE: 0 = CLOSED or ON, 1 = OPEN or OFF, x = don't care</b>			

<sup>13</sup> Recommended SCSI port address is 3 or 4.

## 14 INICI12 / INICT12 Connection

### Overview

INICI12 / INICT12 Overview	
<b>Supported Connections</b>	INFI-Net and the Super Loop in Bailey INFI 90 DCS.
<b>Maximum Tag Capacity</b>	INICI12 supports to 10,000 tags. Driver supports to 30,000 tags
<b>Bailey Document References</b>	ABB Instruction Manual WBPEEU250021A1 Harmony Series CNET-to-Computer Communication Interface INICI12

### Module Structure

The ICI11 consists of the following modules:

- INNIS11 (Network Interface Slave module)
- INICT12 (INFI-NET to Computer Transfer module)
- additional termination components

The INICT12 occupies one slot. The INNIS11 is a slave to the INICT12, which acts as a bus master module. The ICT12 communicates to the NIS over the expander bus. These two modules form a node on the INFI-NET.

The INICT12 is connected to a NTPM01 termination unit. This termination unit provides the physical wiring connections that allow the Driver to be connected to the INICT12 master module. The NTPM01 provides two RS232C serial ports for communication to the INICT12 module. The Driver can use one of these serial ports, communicating at 19,200 Baud.

### Cabling for Serial Communications to INICT12

#### At the INICT12:

Connect the serial RS-232 cable to the 25 pin D connector labeled “Printer”. The wiring of the connector is defined in the CIU driver’s instruction manual.

#### At the Driver:

Connect the serial cable to the selected COM port.

### INNIS11 Setup

Configure INNIS11 per instructions in ABB Manual WBPEEU250022A1 - *CNET-to-HCU Communication Interface, INNIS11/INNPM12*. Must be configured correctly for your specific DCS configuration.

### INICT12 DIP Switch Description

<b>INICT12 DIP Switch Description</b>			
<b>Switch</b>	<b>Pole</b>	<b>Description</b>	<b>Switch Settings / Range</b>
SW3 Operating Mode	1	Hardware Diagnostics	0 = Disabled 1 = Enabled
	2	NIS Diagnostics	0 = Disabled – Normal operation 1 = Enabled
	3	CNET Diagnostics	0 = Disabled – Normal operation 1 = Enabled
	4	NIS Handshake Timeout	0 = Enabled – Normal Operation 1 = Disabled
	5	ROM Checksums	0 = Enabled 1 = Disabled
	6	Modem Password protection	0 = Disabled 1 = enabled
	7	Port addressing mode	0 = Disabled 1 = enabled
	8	Port 1 Utility option	0 = Serial Port to Host computer
SW4 Port Options	½	Serial Port Parity settings (ports 0 and 1)	00 = 8 d, 1s, no parity
			01 = 8 d, 1s, even parity
			10 = 8 d, 1s, odd parity
			11 = 8 d, 2s, no parity
	3/4	Port 0 speed	00 = 2,400 baud
			01 = 4,800 baud
			10 = 9,600 baud
			11 = 19,200 baud
	5/6	Port 1 speed	00 = 2,400 baud
			01 = 4,800 baud
			10 = 9,600 baud
			11 = 19,200 baud
	7	Message Checksums	0 = Disabled 1 = Enabled
	8	Security Key on Port 1	0 = Disabled (Port 1 is 2nd command port)
1 = Enabled (Port 1 key required)			
1 = Utility operation			
<b>INICT12 Switch Settings for Serial Communications</b>			
<b>Switch SW3</b>		LSB 00000000 MSB	
<b>Switch SW4</b>		LSB 00111110 MSB	
<b>NOTE: 0 = CLOSED or ON, 1 = OPEN or OFF, x = don't care</b>			