

Purpose

The NTRL02 Terminal Unit (TU) provides NR002 Remote I/O (RIO) Modules and field equipment with a remote communication interface via a 1 Megabit/second fiber optic data link. The NTRL02 is designed for point-to-point communication and allows for a maximum cable distance between a master and slave RIO of 10,000 feet (3000 meters). This distance can be doubled by using two TUs with JP1 jumpered for repeater mode, and a remote +24 Vdc power supply. This TU also supports communication to Dgta Control and Dgta Indicator Stations.

Description

The NTRL02 Terminal Units shown in Figure 1 require +24 Vdc I/O power to drive its circuitry and has a maximum current consumption of 170 mA. A 25 Amp fuse (F1) provides input protection, and a 5 Amp fuse (F1) provides input protection and a 5 Amp fuse (F2) is fused to the Dgta Stations.

The following steps must be performed before the NTRL01, NTRL02, or NTRL03 Terminal Units are put into operation.

Handling

Special Handling

The NTRL01, NTRL02, and NTRL03 TUs use Electrostatic Sensitive (ESD) devices. Follow these handling procedures:

1. Keep the TU in the special static bag until you are ready to install it in the system. Save the bag for future use.
2. Ground the antistatic bag before opening.
3. Verify that all devices connected to the TU are properly grounded before using it.
4. Avoid touching the circuitry when handling the TU.

NOTE: Grounding straps (feet static kits) must be used when installing or removing the TU to configure or change jumper settings.

General Handling

1. Examine the TU immediately to verify that no damage has occurred in transit.

TABLE 1 NTRL02 Application Summary

INTERFACES TO	CABLE	APPLICATION
Remote I/O Module NR002	NKLM01	Provides communication between NR002s and the NTRL02.
NTRL02	Fiber Optic	Provides communication between NR002s.
Dgta Control Station NDCS03	NKDS01 NKDS02	Provides communication between NR002 and NDCS03 with or without bypass or ND S01.
Control Station Terminal Unit NTCS02	NKSE01	Provides communication between NR002s and NDCS03 with or without bypass or ND S01.

NTRL02

2. Notify the nearest Bailey Control Sales/Service Office of any damage.

3. File a claim for any damage with the transportation company that handled the shipment.

4. Use the original packing material and/or container to store the TU.

5. Store the TU in an environment of good air quality, and free from temperature and moisture extremes.

Installation

The NTRL02 TU can mount on a Field Termination Panel within a Process Control Unit (PCU), remotely. The maximum distance between the NTRL02 and NR002 is 200 feet (60 meters). Please refer to the Termination Unit and Cable Installation section of this manual for complete installation instructions or other information as necessary.

Cable Connection

An NKLMO1 cable connects between P1 on the TU and P3 on the RO Fiber optic cable connects two TUs via TX and RX.

Exercise caution when connecting fiber optic cables. Pay strict attention to the bend radius specification on pulling tensile strength during installation and normal system operation. Termination of the fiber optic cable with SMA type connectors must be performed by qualified personnel.

Fiber Optic Budget

The optical link has a minimum of 15 decibels (dB) of power that can be expended in a system. This is referred to as the Power Budget. The 15 dB of power that can be expended in a system. This is referred to as the Power Budget. The 15 dB of power is guaranteed when 62.5/125 micrometer fiber size is used.

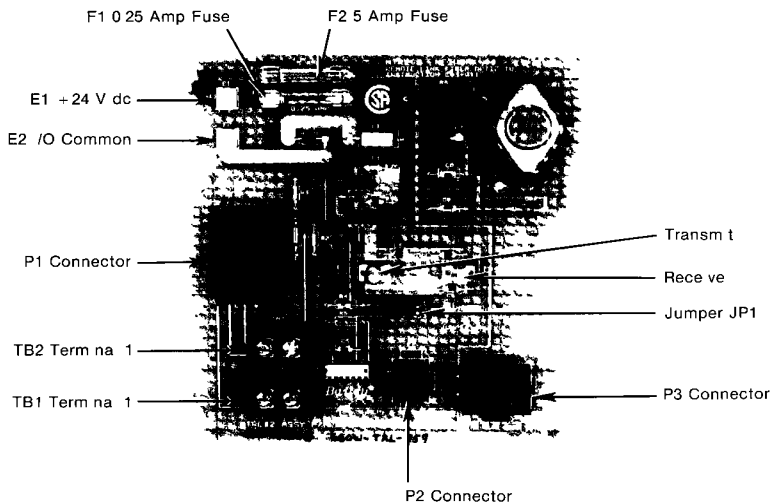

FIGURE 1 NTRL02 Termination Unit

The Power Budget determines the maximum distance over which the link can operate. The losses in a system measured in relative decibels, are due to fiber losses specified in dB/km, and losses due to connectors or splices in the system. The 62.5/125 fiber is available in 2 km maximum lengths with the maximum loss rates at 3.3 dB/km.

Example

If 3 km of cable is used the insertion loss due to the fibers is

$$3.3 \text{ dB/km} \times 3 \text{ km} = 9.9 \text{ dB}$$

Connector losses, if installed properly amount to an average of 1 dB per connector

If one connection is made in the cable the total loss due to connectors is 3 dB. This includes 1 dB each as the receiver and transmitter

The total loss to the system is

$$9.9 \text{ dB} + 3 \text{ dB} = 12.9 \text{ dB}$$

There would then be 2.1 dB left in the Power Budget (15 dB - 12.9 dB = 2.1 dB). This is the safety margin and should be at least 2 dB to allow for component degradation.

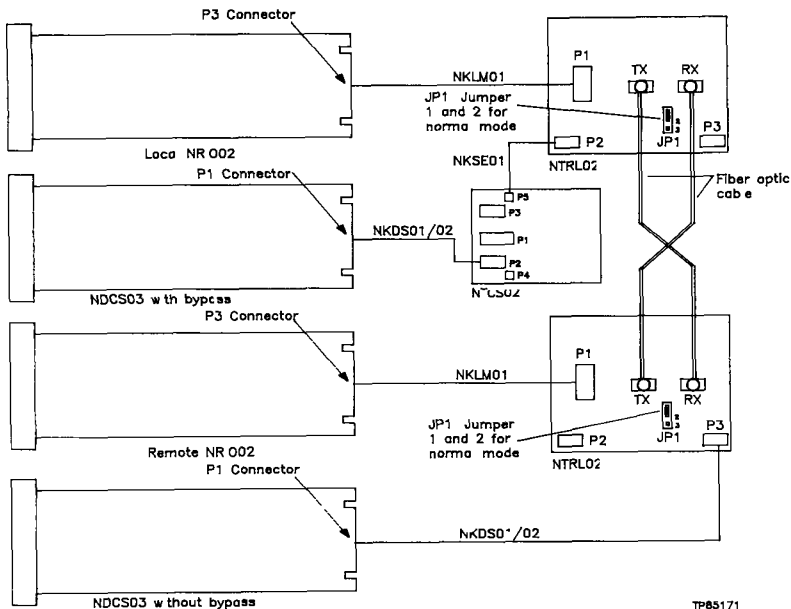
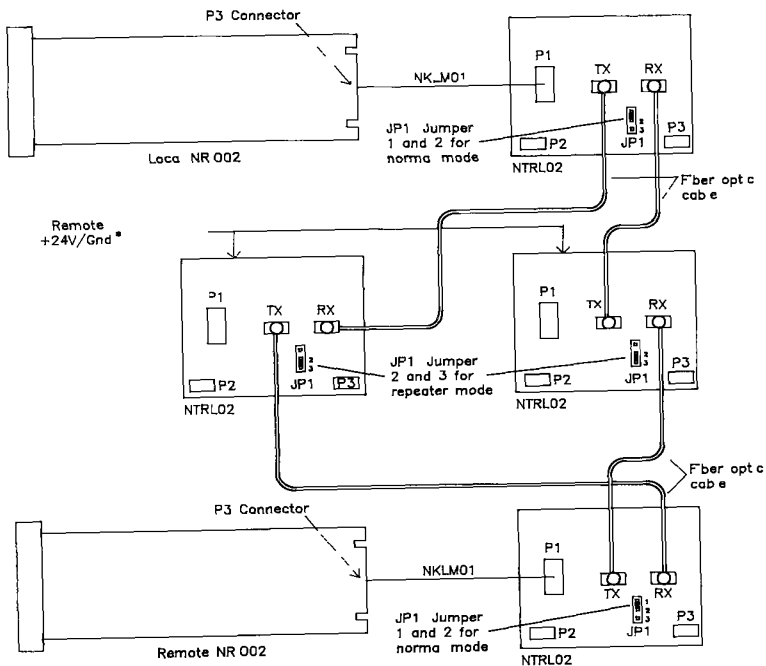

FIGURE 2 Cable Connections for NTRL02 Normal Mode

NTRL02



* If this remote power is removed for any reason the communication link will stop operating

TP85170

FIGURE 3 Cable Connections for NTRL02 Repeater Mode

Bailey Controls

NTDO01

Digital Outputs

Purpose

This Terminal Unit serves as an interface between the Digital Slave Module (NDSM05) and field wiring from AC or DC loads. The TU provides solid state relays for load switching.

Description

The NTDO01 Terminal Unit is shown in Figure 1.

Installation

Please refer to the Terminal Unit and Cable Installation section of this manual for complete instructions on installing the Terminal Unit.

Additional Cable Installation Procedures

In addition to the standard Terminal Unit Cable Installation procedures (see the Terminal Unit and Cable Installation section of this manual), the Terminal Unit can be connected to other Terminal Units and solid state relays. This is done using a Daisy Chain Cable (NKDO01) connected to the P2 plug of the Terminal Unit. Figure 2 depicts the cable connections between this Terminal Unit and the NDSM05 Digital Slave Module. The figure also shows connection between two NTDO01 Terminal Units, since the NDSM05 handles 16 outputs and each TU handles eight.

TABLE 1 NTDO01 Application Summary

INTERFACES TO	APPLICATION/SIGNAL TYPE	CONNECTING CABLE	NUMBER OF OUTPUTS
DIGITAL SLAVE MODULE NDSM05	120 V ac or 24 V dc	NKTU01	8
TERMINAL UNIT NTDO01	Enables user to daisy chain Digital Slave Modules together to increase the number of outputs	NKDO01	

NTDO01

Configuring the XU1 and XU2 Dipshunts

The XU1 and XU2 dipshunts are used to allow any Digital Slave Module (DSM) output to control any solid state relay(s), with a maximum of nine per output. This means that a maximum of 18 Terminal On Units can be easily chained together by NKDO01 cables and controlled by one DSM.

If an unprogrammed dipshunt is placed into the XU1 or XU2 socket, each output from group A or group B on the DSM controls one solid state relay on the Terminal On Unit of group A's outputs (1 through 8)

are a ready controlling one relay and group B's outputs (9 through 16) are needed, then another NTDO01 Terminal On Unit must be used.

If one output from the DSM has to control more than one relay, a socket adapter is inserted into the XU1 or XU2 sockets. An example of both cases is shown below. For the socket adapter application, the first output of either group A or B is set to control six relays. The second output from either group A or B is set to control up to two relays. If more relays are desired, then another Terminal On Unit(s) must be added.

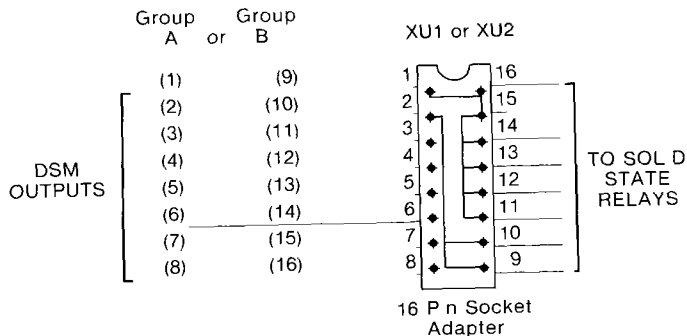
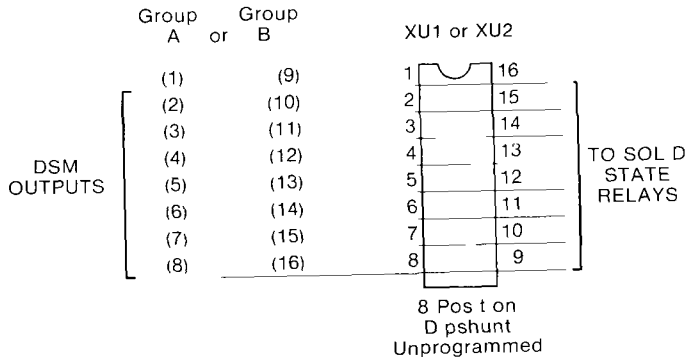

Typical Example Output 1 Driving 6 Relays, Output 2 Driving 2 Relays

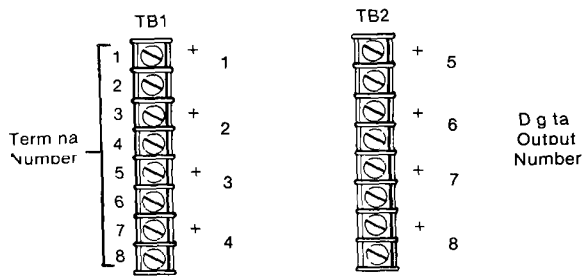
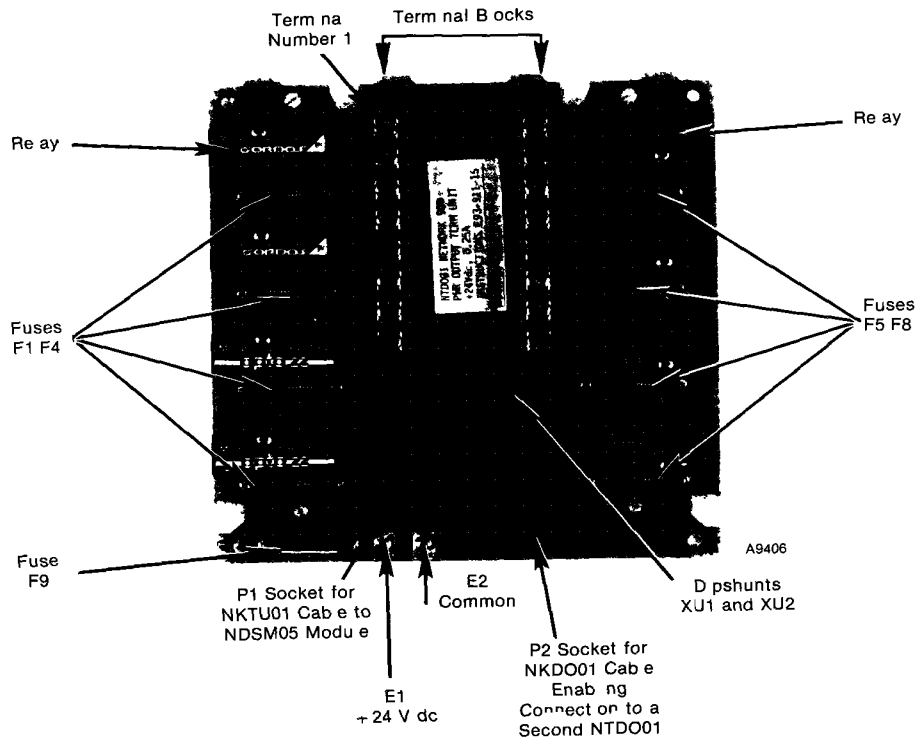

FIGURE 1 NTDO01 Termination Unit and Terminal Assignments

NTDO01

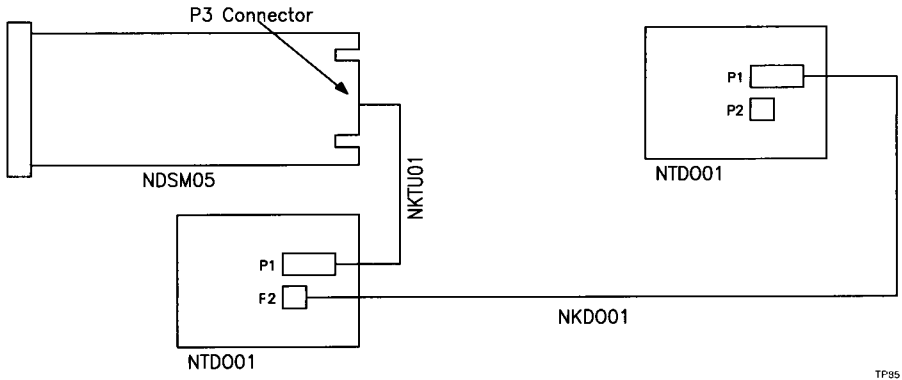

FIGURE 2 Cable Connections for the NTDO01

TP95 4-

Purpose

This Termination Unit provides the interface for

- field wiring when a NC S01/02 Slave Modules used to supply analog and digital field I/O
- Digital Control Stations and Digital Indicator Stations
- Controller Modules (NCOM02/03/04), Quick Response Controllers (NQRC01), Multi-Function Controllers, and Bailey PC-90™ Processors

Description

The NTCS02 Termination Units shown in Figure 1 I/O options are selected by means of dipswitch configurations. See Table 1.

Installation

Please refer to the Termination Unit and Cable Installation section of this manual for complete instructions on installing this Termination Unit.

Cable Installation Procedure

The Serial Extension Cable (NKSE01) enables the NTCS02 Termination Unit to be connected to the NTMF01 Termination Unit as follows: NTCS02 Termination Units to be daisy-chained for Multi-Function Controller to Station communication. The NKSE01 cable connects to the P2 connector on the NTMF01 Termination Unit and to the P4 or P5 connector on the NTCS02 Termination Unit.

The Serial Link Cable (NKSL01) connects the Multi-Function Controller to the NTCS02 Termination Unit. This cable is connected to the P1 or P2 connector of the Termination Unit and the P3 connector of the Multi-Function Controller on the CPU Board.

The Termination Unit Cable (NKTU01) connects the Termination Unit to the Controller I/O Slave Module (NC S01).

The NKDS01 Digital Station Cable or NKDS02 (with a Series Connector for daisy-chaining) links the Termination Unit, via the P1 connector to a Digital Control Station (using the P2 or P3 connectors). Figure 2 shows sample cabling configurations using the NTCS02 Termination Unit.

NTCS02

TABLE 1 NTCS02 Application Summary

MODULE (CABLE)	APPLICATION/ SIGNAL TYPE	D PSHUNT CONFIGURATION*
CONTROLLER /O SLAVE MODULE NC S01/02 (NKTU01)	ANALOG INPUT VARIABLES system powered 4 20 mA	D PSHUNTS XU1 XU4 1 2 3 4 5 6 7 8 1 0 1 0 0 1 1 1
CONTROLLER MODULE NCOM02/03/04 (NKTU01)	externally powered 4 20 mA	1 2 3 4 5 6 7 8 0 1 0 1 0 1 0 1
MULTIFUNCTION CONTROLLER MODULE NMFC01/02/03/04 (NKSL01, NKTU01)	single ended voltage	1 2 3 4 5 6 7 8 0 1 0 1 0 0 1 1
	differentia voltage	1 2 3 4 5 6 7 8 0 1 0 1 1 0 0 0
BAILEY PC 901* PROCESSOR MODULE NMPC01 (NKTU01)	DIGITAL INPUT VARIABLES analog + 24 V dc /O supply in series	D PSHUNTS XU5 XU7 1 2 3 4 5 6 7 8 0 0 0 0 1 0 1 0
QUICK RESPONSE CONTROLLER NQR01 (NKTU01)	separate (+ 24/- 25 V dc) /O supply in series	1 2 3 4 5 6 7 8 - 0 - 0 0 0 0 0
QUICK RESPONSE SLAVE NQRS01/02 (NKTU01)	no supply in series	1 2 3 4 5 6 7 8 0 0 0 0 0 0 0 1

* 1-8 represent strap numbers for d pshunts XU1 through XU9 where 0 represents a cut strap and 1 represents an uncut strap

NOTE The NTCS02 Terminal Unit handles 4 Analog Inputs, 2 Analog Outputs, 3 Digital Inputs, and 4 Digital Outputs

TABLE I NTCS02 Application Summary (cont.)

MODULE (CABLE)	APPLICATION/ SIGNAL TYPE	DPSHUNT CONFIGURATION
CONTROLLER MODULE NCOM02/03/04 (NKTU01)	ANALOG INPUT FEEDBACK VAR AT ONS	D PSHUNT XU8
DGTAL CONTROL STAT ON NDCS02/03 (NKDS02)	analog inputs 3 and 4 routed to stations 1 and 2 (socket P2 or P3 respectively)	1 2 3 4 5 6 7 8 1 1 0 1 1 0 0 0
DGTAL INDICATOR STAT ON ND S01 (NKDS02)	analog input 3 routed to station 1 ONLY (socket P2)	1 2 3 4 5 6 7 8 1 1 0 0 0 1 0 0
MULTI FUNCTION CONTROLLER MODULE NMFC01/02/03/04 (NKSL01, NKTU01)	analog input 4 routed to station 2 ONLY (socket P3)	1 2 3 4 5 6 7 8 0 0 1 1 1 0 0 0
BAILEY PC 90™ PROCESSOR MODULE NMPC01 (NKTU01)	NO analog input routed to either station	1 2 3 4 5 6 7 8 0 0 1 0 0 1 0 0
QUICK RESPONSE CONTROLLER NQRC01 (NKTU01)		

NTCS02

TABLE 1 NTCS02 Application Summary (cont.)

MODULE (CABLE)	APPLICATION/ SIGNAL TYPE	DIPSHUNT CONFIGURATION
CONTROLLER /O SLAVE MODULE NC S01/02 (NKTU01)	ANALOG OUTPUT VARIABLES both outputs are in voltage mode	DIPSHUNT XU9 1 2 3 4 5 6 7 8 1 1 0 0 0 0 1 1
CONTROLLER MODULE NCOM02/03/04 (NKTU01)	analog output 1 in voltage mode, analog output 2 in current mode	1 2 3 4 5 6 7 8 1 1 0 0 0 0 0 0
MULTIFUNCTION CONTROLLER NMFC01/02/03/04 (NKSL01, NKTU01)	analog output 1 in current mode, analog output 2 in voltage mode	1 2 3 4 5 6 7 8 0 0 0 0 0 0 1 1
BAILEY PC 90™ PROCESSOR MODULE NMPCC1 (NKTU01)	both outputs are in current mode	1 2 3 4 5 6 7 8 0 0 0 0 0 0 0 0
QUICK RESPONSE CONTROLLER NQRC01 (NKTU01)		
QUICK RESPONSE SLAVE NQRS01/02 (NKTU01)		

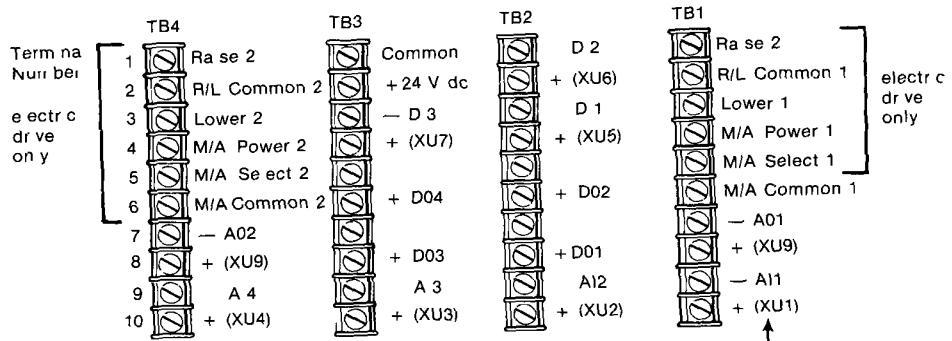
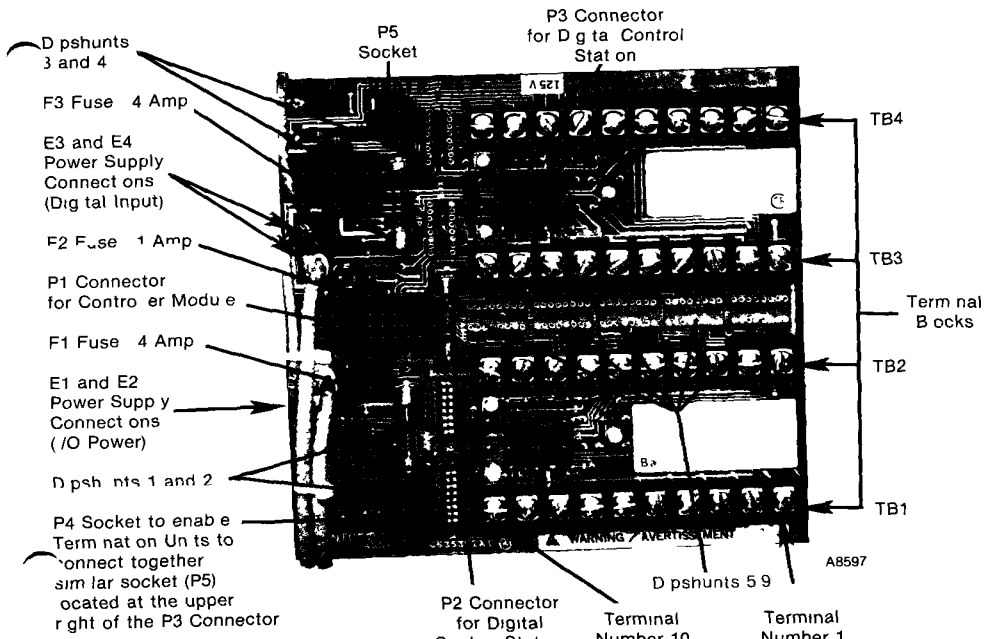

electrical drive only

NOTE A
 AO Analog Input Analog Output
 DO Digital Output
 D Digital Input
 M/A = Manual / Automatic
 D pshunt Used for IO

FIGURE 1 NTCS02 Termination Unit and Terminal Assignments

NTCS02

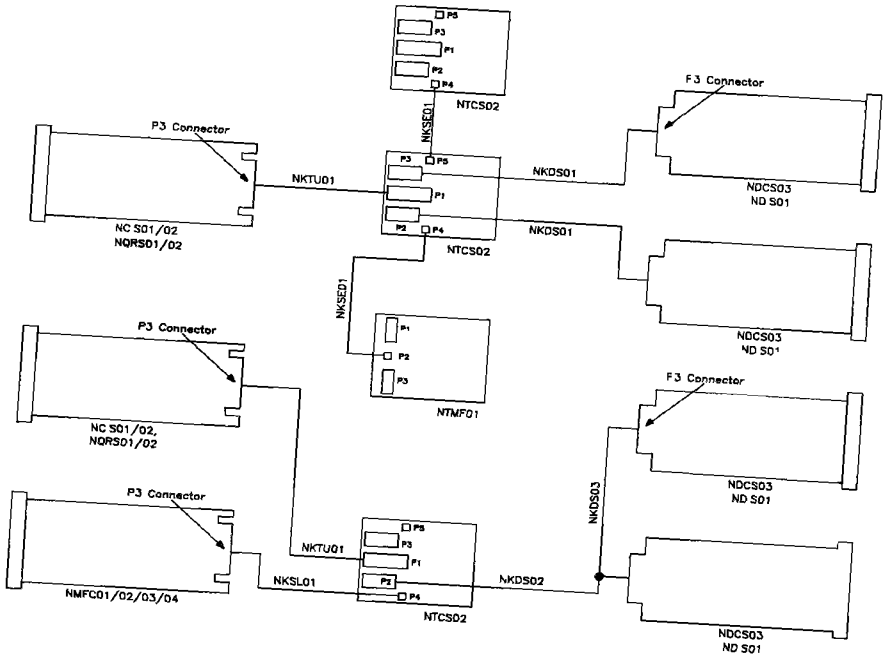

TPB5144

FIGURE 2 Cable Connections for the NTCS02

**Resistance Temperature Detector
Inputs (RTD)****Purpose**

This Terminal Unit is the interface between the feed wiring from RTD sensors and one or two Analog Slave Modules (NASM03)

Description

The NTA03 Terminal Unit is shown in Figure 1

Installation

Please refer to the Terminal Unit and Cable Installation section of this manual for complete instructions for installing this Terminal Unit

Additional Cable Installation Procedures

In addition to the standard Terminal Unit Cable installation procedures (see the Terminal Unit and Cable Installation section of this manual) the P2 socket connects the Terminal Unit to a second Analog Slave Module. Figure 2 shows the cable connection between the NTA03 Terminal Unit and the NASM03 Analog Slave Module

This TU provides a socket for calibrating a slave module by the master. See the **Analog Master Module — NAMM02 — Calibration Guide (Product Instruction Supplement — IS-E93-912-2)** for details

TABLE 1 NTAI03 Application Summary

INTERFACES TO	CONNECTING CABLE	APPLICATION/SIGNAL TYPE	NUMBER OF INPUTS
ANALOG SLAVE MODULE NASM03 and RTD Inputs	NKTU01	100 Ohm Pat num RTD	16

NTAI03

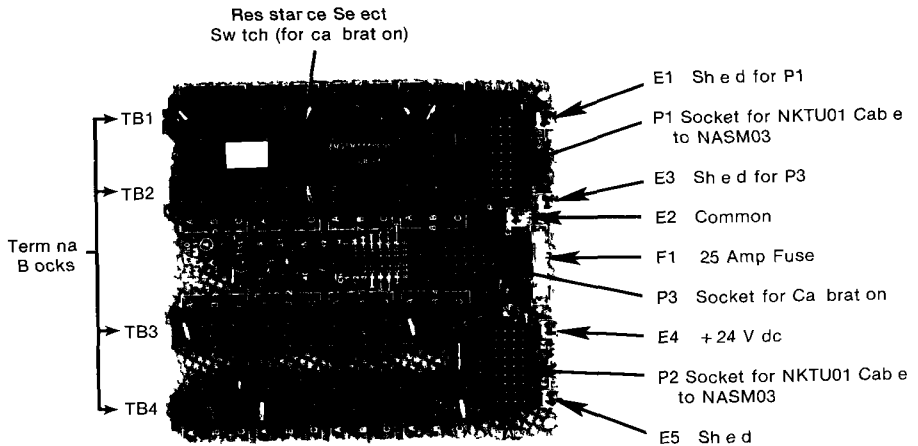

A8140

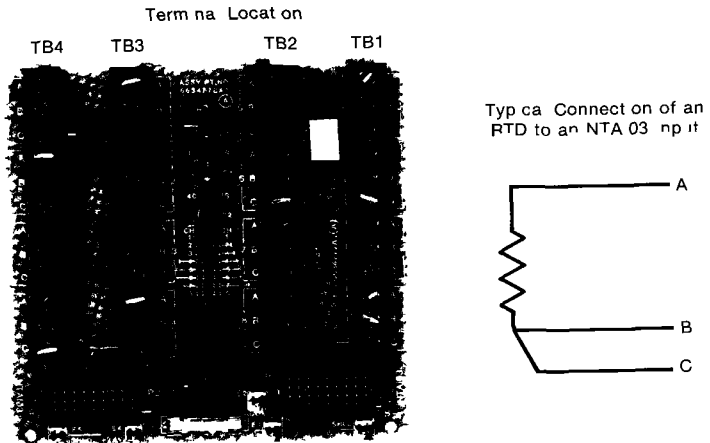
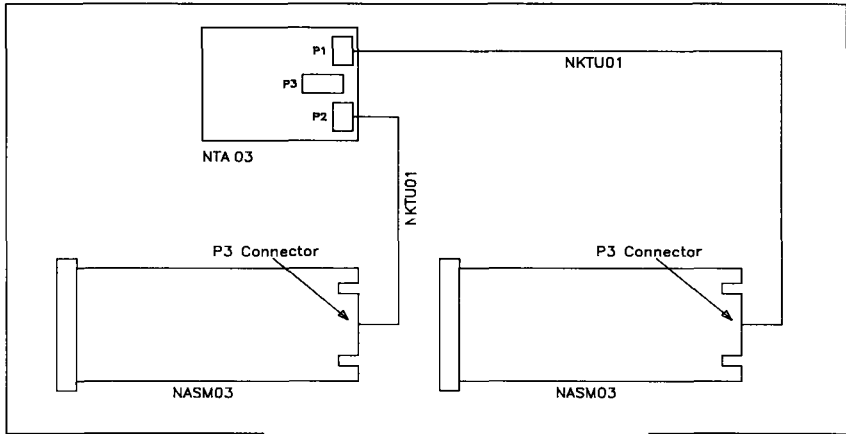
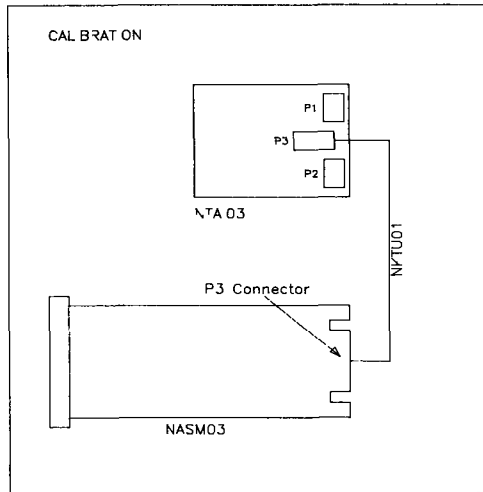

FIGURE 1 NTAI03 Termination Unit and Terminal Assignments



TP85139A



TP85139B

FIGURE 2 Cable Connections for the NTAI03

00 43 46 04 11 07

Purpose

This Termination Unit serves as an interface between the field wiring of the plant process and either an Analog Master Module (NAMM01) or an Analog Slave Module (NASM01). It also accommodates (via an eight position dipswitch in a socket) analog inputs of different types: specifically system powered or externally powered 4 to 20 mA current loops and single ended or differential voltage inputs on an industrial basis.

Description

The NTAI01 Termination Unit is shown in Figure 1. The P1 socket links this Termination Unit to its

respective module via the Termination Unit Cable (NKTU01). Analog input options are selected by means of dipswitch configuration (see Table 1).

Installation

Please refer to the Termination Unit and Cable installation section of this manual for complete installation instructions. Figure 2 shows the cable connection between this Termination Unit and the NAMM01 Analog Master Module.

TABLE 1 NTA101 Application Summary

INTERFACES TO	CONNECTING CABLE	NUMBER OF INPUTS	APPLICATION/SIGNAL TYPE	DIPSWITCH CONFIGURATION*
ANALOG MASTER MODULE NAMM01 or ANALOG SLAVE MODULE NASM01	NKTU01	8 (master) 16 (slave)	system powered 4.20 mA	DIPSHUNTS XU1 XU16 1 2 3 4 5 6 7 8 1 0 1 0 0 1 1 1
			externally powered 4.20 mA	1 2 3 4 5 6 7 8 0 1 0 1 0 1 0 1
			single ended voltage	1 2 3 4 5 6 7 8 0 1 0 1 0 0 1 1
			different voltage	1 2 3 4 5 6 7 8 0 1 0 1 1 0 0 0

*1 8 represent strap numbers on dipshunts XU1 through XU16 where 0 represents a cut strap and 1 represents a strap left intact. Strap one connects pin one to pin 16, strap two connects pin two to pin 15 etc

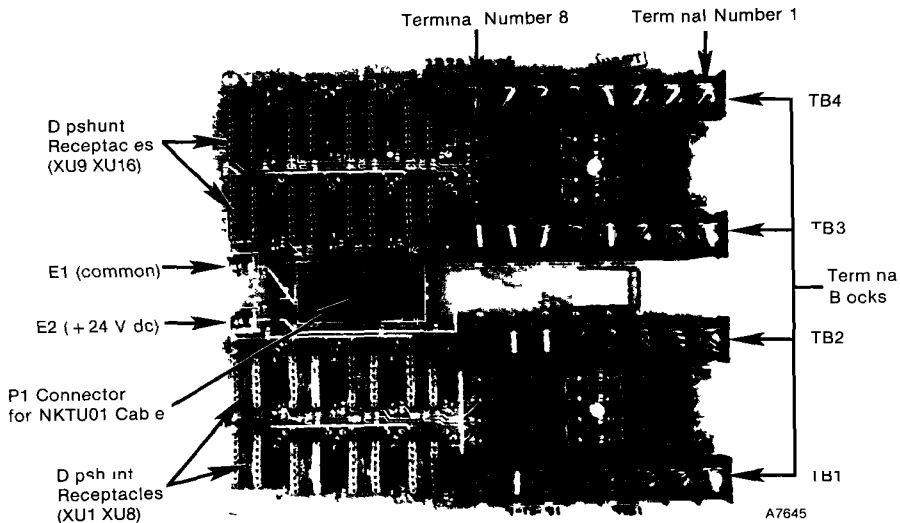

NOTE The d shunt number corresponds numerically to the analog input number

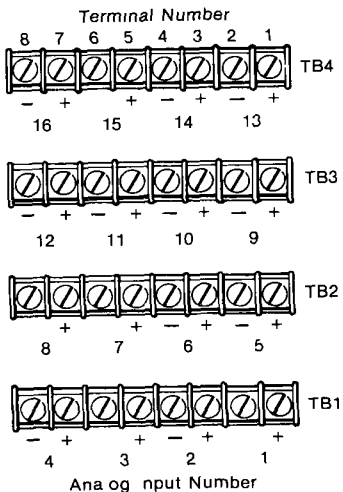
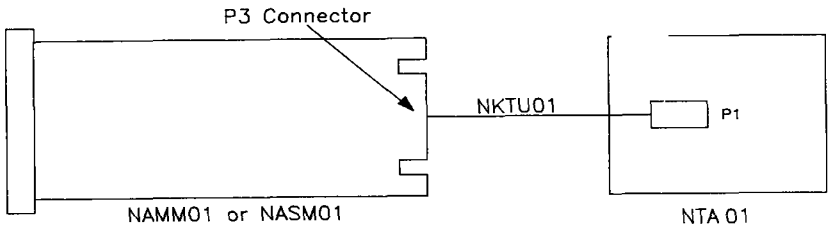

FIGURE 1 NTAI01 Termination Unit and Terminal Assignments

NTAI01



TP85137

FIGURE 2 Cable Connections for the NTAI01

Bailey Controls

NIPL01

Termination Module, Plant Loop

Purpose

This Termination Module provides two way access between the Loop Interface Module and the Plant Communication Loop. It also provides electrical isolation on surge protection and bypass capability.

Description

This Termination Module is shown in figure 1.

Installation

Please refer to the Termination Module and Cable Installation section of this manual for complete instructions on installing this Termination Module.

Cable Installation Procedure

The Termination Module Cable (NKTMO1), a 30 conductor ribbon cable connects the Termination Module to the Loop Interface Module. Connect the cable to the P1 connector on the Termination Module and the Loop Interface Module slot on the back of the Module Mounting Unit. Install this cable on the Module Mounting Unit BEFORE inserting the Loop Interface Module.

TABLE 1 NIPL01 Application Summary

INTERFACES TO	CONNECTING CABLE	APPLICATION
Loop Interface Module NLIM02	NKTMO1	Termination point for messages to/from the Plant Loop
Plant Loop	NKPL01	Connects Node to Plant Loop

WARNING

Repacing the NIPL01 with the NICL01 requires repacing the NKTMO1 cable with the NKLS04 cable. Failure to replace the cable will result in damage to the NL M02. Use caution when making a connection with the NKLS04. The cable end marked J1 connects to the NCL01 and the cable end marked J2 connects to the NLIM02. Failure to correctly connect the NKLS04 cable can damage the NL M02 or NCL01.

AVERTISSEMENT

Lorsqu'on remplace le NIPL01 par le NICL01, on doit également remplacer le câble et NKTMO1 par le câble et NKLS04. Soignez-vous de remplacer le câble et NL M02 pour éviter l'endommagement. Au moment de brancher le NKLS04, assurez-vous de raccorder l'extrémité du câble denté par J1 au NCL01 et l'extrémité dentée par J2 au NL M02. Si le câble n'est pas branché correctement, le NL M02 ou le NICL01 pourra être endommagé.

NIPLO1

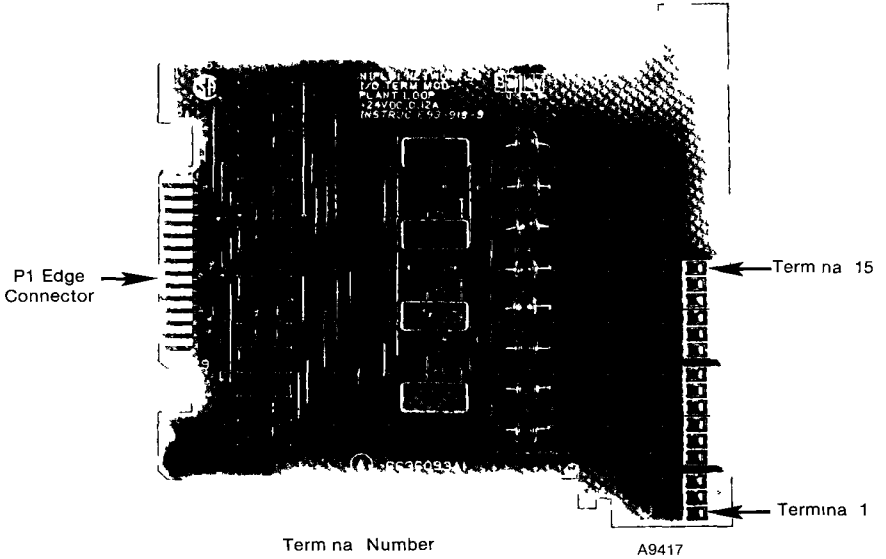

Term na Number

1		Ground
2		Common
3		+24 V dc
4		Loop 2 Sh e d
5		Loop 2 Out,
6		Loop 2 Out +
7		Loop 2 Sh e d
8		Loop 2 n
9		Loop 2 n +
10		Loop 1 Sh e d
11		Loop 1 Out.
12		Loop 1 Out +
13		Loop 1, Sh e d
14		Loop 1 n
15		Loop 1 n +

FIGURE 1 NIPLO1 Termination Module and Terminal Assignments

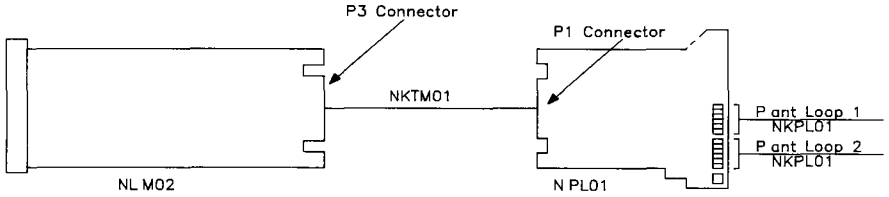

TP85134

FIGURE 2 Cable Connections for the NIPL01

Term nat on Module, Analog
Inputs**Purpose**

This Term nat on Modu e serves as an interface between the Ana og Slave Modu e (NASM01) and equipment such as two-wire transmitters. It also accommodates (via eight position d psw tches) ana og nputs of different types: specifcally system powered or externally powered 4 to 20 mA current loops, and single ended or differential voltage nputs on an nd v dua bas s.

Description

The NIA 01 Term nat on Modu e is shown n Figure 1. An NKT M01 or NKTU02 cable connects between the

P1 connector of the TM and the P3 connector of the Ana og Slave Modu e. Ana og nput options are selected by means of d psw tch conf gurat ons (see Table 1).

Installation

Please refer to the Term nat on Modu e and Cable nstallation section of this manual for complete instructions on nstalling this Term nat on Modu e and its cable. Figure 2 shows the cable connection between this Term nat on Modu e and the NASM01 Ana og Slave Modu e.

TABLE 1 NIA101 Application Summary

INTERFACES TO	CONNECTING CABLE	NUMBER OF INPUTS	APPLICATION/SIGNAL TYPE	DIPSWITCH CONFIGURATION*
ANALOG SLAVE MODULE NASM01	NKT M01 or NKTU02	15	ANALOG INPUT VARIATIONS	DIPSWITCHES S1-S15
			system powered 4-20 mA dc	1 2 3 4 5 6 7 8 1 1 1 1 1 1 0 0
			externally powered 4-20 mA dc	1 2 3 4 5 6 7 8 0 0 0 0 1 1 1 1
			differential voltage	1 2 3 4 5 6 7 8 0 0 0 0 0 0 1 1
			single ended voltage	1 2 3 4 5 6 7 8 0 0 0 1 0 1 1 1

*1-8 represent switch positions on d psw tches S1 through S15 where 0 is open and 1 is closed

NIAI01

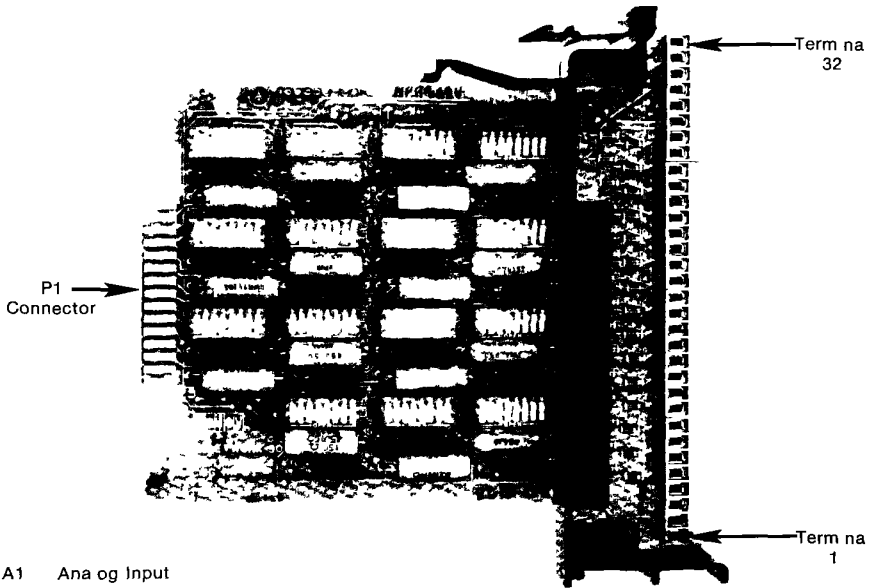

A1 Ana og Input

NOTE The dipsw tch number corresponds numer ca y to the ana og nput number

A9402

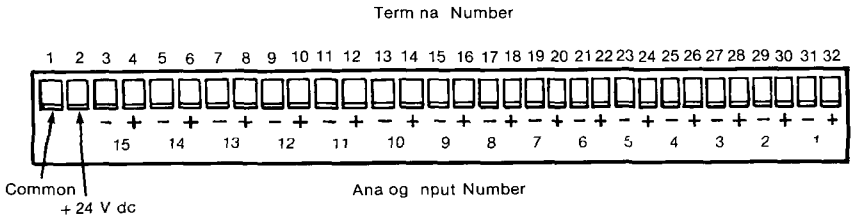
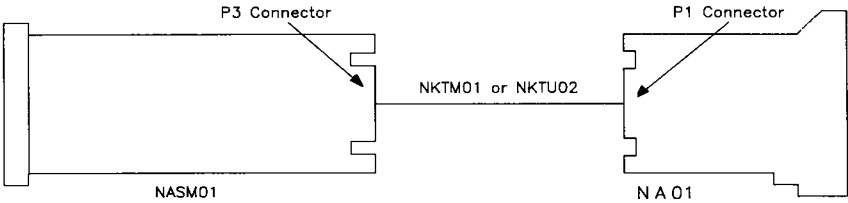

FIGURE 1 NIAI01 Termination Module and Terminal Assignments



TP85123

FIGURE 2 Cable Connections for the NIAI01

