

E97-303

# Instruction

## Single Drive Slave Module (IMDER01)

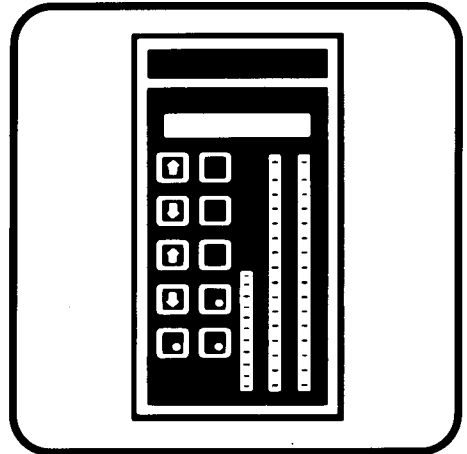
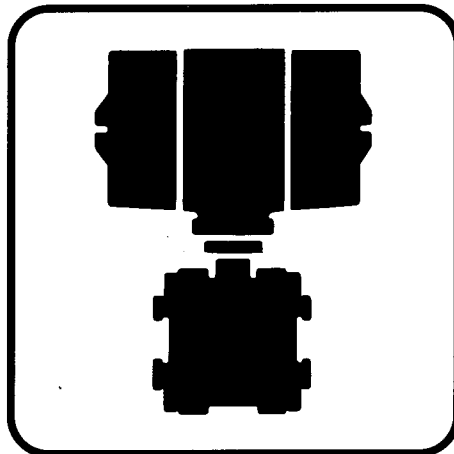
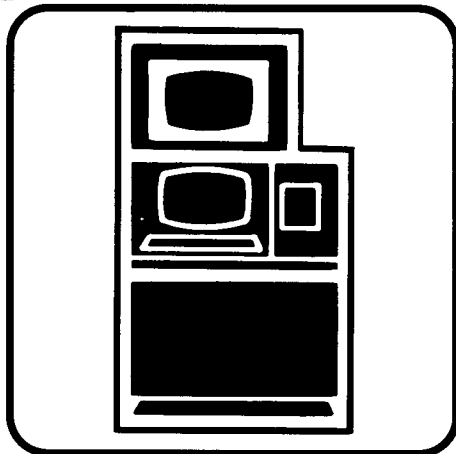
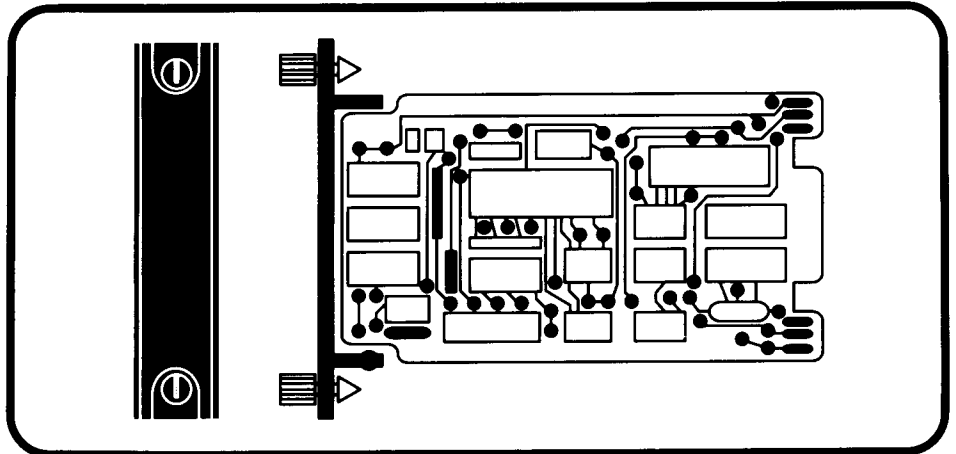
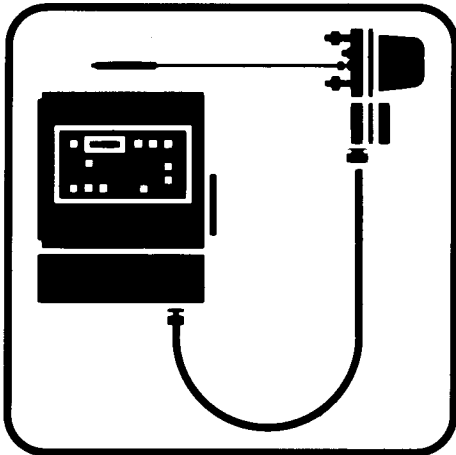

**WARNING** notices as used in this manual apply to hazards or unsafe practices which could result in personal injury or death.

**CAUTION** notices apply to hazards or unsafe practices which could result in property damage.

**NOTES** highlight procedures and contain information which assist the operator in understanding the information contained in this manual.

## WARNING

### INSTRUCTION MANUALS

DO NOT INSTALL, MAINTAIN OR OPERATE THIS EQUIPMENT WITHOUT READING, UNDERSTANDING AND FOLLOWING THE PROPER **Elsag Bailey** INSTRUCTIONS AND MANUALS, OTHERWISE INJURY OR DAMAGE MAY RESULT.

### RADIO FREQUENCY INTERFERENCE

MOST ELECTRONIC EQUIPMENT IS INFLUENCED BY RADIO FREQUENCY INTERFERENCE (RFI). CAUTION SHOULD BE EXERCISED WITH REGARD TO THE USE OF PORTABLE COMMUNICATIONS EQUIPMENT IN THE AREA AROUND SUCH EQUIPMENT. PRUDENT PRACTICE DICTATES THAT SIGNS SHOULD BE POSTED IN THE VICINITY OF THE EQUIPMENT CAUTIONING AGAINST THE USE OF PORTABLE COMMUNICATIONS EQUIPMENT.

### POSSIBLE PROCESS UPSETS

MAINTENANCE MUST BE PERFORMED ONLY BY QUALIFIED PERSONNEL AND ONLY AFTER SECURING EQUIPMENT CONTROLLED BY THIS PRODUCT. ADJUSTING OR REMOVING THIS PRODUCT WHILE IT IS IN THE SYSTEM MAY UPSET THE PROCESS BEING CONTROLLED. SOME PROCESS UPSETS MAY CAUSE INJURY OR DAMAGE.

## AVERTISSEMENT

### MANUELS D'OPERATION

NE PAS METTRE EN PLACE, REPARER OU FAIRE FONCTIONNER CE MATERIEL SANS AVIOR LU, COMPRIS ET SUIVI LES INSTRUCTIONS REGLIMENTAIRES DE **Elsag Bailey** TOUTE NEGLIGENCE A CET EGARD POURRAIT ETRE UNE CAUSE D'ACCIDENT OU DE DEFAILLANCE DU MATERIEL.

### PERTURBATIONS DE LA FREQUENCE RADIOPHONIQUE

LA PLUPART DES EQUIPEMENTS ELECTRONIQUES SONT SENSIBLES AUX PERTURBATIONS DE LA FREQUENCE RADIO. DES PRECAUTIONS DEVRONT ETRE PRISES LORS DE L'UTILISATION DE MATERIEL DE COMMUNICATION PORTATIF. LA PRUDENCE EXIGE QUE LES PRECAUTIONS A PRENDRE DANS CE CAS SOIENT SIGNALEES AUX ENDROITS VOULOUS DANS VOTRE USINE.

### PERTES PROCEDE RENVERSEMENTS

L'ENTRETIEN DOIT ETRE ASSURE PAR UN PERSONNEL QUALIFIE ET EN CONSIDERATION DE L'ASPECT SECURITAIRE DES EQUIPEMENTS CONTROLES PAR CE PRODUIT. L'ADJUSTEMENT ET/OU L'EXTRACTION DE CE PRODUIT LORSQU'IL EST INSERE A UN SYSTEME ACTIF PEUT OCCASIONNER DES A-COUPS AU PROCEDE CONTROLE. SUR CERTAINS PROCEDES, CES A-COUPS PEUVENT EGALEMENT OCCASIONNER DES DOMMAGES OU BLESSURES.

## NOTICE

The information contained in this document is subject to change without notice.

Elsag Bailey Company, its affiliates, employees, and agents, and the authors of and contributors to this publication specifically disclaim all liabilities and warranties, express and implied (including warranties of merchantability and fitness for a particular purpose), for the accuracy, currency, completeness, and/ or reliability of the information contained herein and/ or for the fitness for any particular use and/ or for the performance of any material and/ or equipment selected in whole or part with the user of/ or in reliance upon information contained herein. Selection of materials and/ or equipment is at the sole risk of the user of this publication.

This document contains proprietary information which is protected by copyright. All rights are reserved. No part of this document may be photocopied or reproduced without the prior written consent of **Elsag Bailey Company**.

---

## Preface

---

The Single Drive Slave Module (IMDER01) is a Slave Module used to connect sixteen field inputs and provide to the field eight outputs. The IMDER01 module and the relevant NTU-7C8 termination unit are especially designed to implement single drive I/O interfaces for ON/OFF final actuators and relevant mosaic tiles handling.

This manual describes slave module features, specifications and operations. It details the procedures you must follow to set up and install an IMDER01 module, and explains status indicators that help in system testing and diagnostics.

The system engineer or technician using the IMDER01 should read and understand this instruction before installing and operating the slave module. In addition, a complete understanding of the INFI 90 system is beneficial to the user.

---

## List of Effective Pages

---

Total number of pages in this manual is 56, consisting of the following:

<b>Page No.</b>	<b>Change Date</b>
Preface	Original
List of Effective Pages	Original
I through VI	Original
1-1 through 1-8	Original
2-1 through 2-8	Original
3-1 through 3-12	Original
4-1 through 4-2	Original
5-1 through 5-4	Original
6-1 through 6-2	Original
7-1 through 7-2	Original
8-1 through 8-2	Original
A-1 through A-8	Original

When an update is received, insert the latest changed pages and dispose of the superseded pages.

**NOTE:** On an updated page, the changed text or table is indicated by a vertical bar in the outer margin of the page adjacent to the changed area. A changed figure is indicated by a vertical bar in the outer margin next to the figure option.

---

# Table of Contents

	Page
<b>SECTION 1 - INTRODUCTION</b>	<b>1-1</b>
OVERVIEW	1-1
INTENDED USER	1-1
MODULE DESCRIPTION	1-1
FEATURES	1-3
INSTRUCTION CONTENT	1-3
HOW TO USE THIS MANUAL	1-3
REFERENCE DOCUMENTS	1-4
NOMENCLATURE	1-4
GLOSSARY OF TERMS AND ABBREVIATIONS	1-5
SPECIFICATIONS	1-6
<b>SECTION 2 - DESCRIPTION AND OPERATION</b>	<b>2-1</b>
INTRODUCTION	2-1
INPUTS	2-1
Input Circuits	2-1
Input Circuit Description	2-2
OUTPUTS	2-4
Output Circuits	2-4
Output Circuits Description	2-5
I/O Circuit Connections	2-6
CONTROL LOGIC	2-6
I/O Point Data Byte	2-6
Status Byte	2-7
LOGIC POWER	2-7
SLAVE EXPANDER BUS	2-7
UNIVERSAL SLAVE EXPANDER BUS INTERFACE	2-7
<b>SECTION 3 - INSTALLATION</b>	<b>3-1</b>
INTRODUCTION	3-1
SPECIAL HANDLING	3-1
UNPACKING AND INSPECTION	3-1
IMDER Configuration	3-2
Slave Address Selection (SW2, E1, E2, E3, E5, E6, E8)	3-2
Single addressing mode	3-2
Dual (contiguous) Addressing Mode	3-4
Dual (not contiguous) Addressing Mode	3-6
Digital Output (SW1, E4) Configuration	3-7
Digital Input Power Supply Detection Configuration (E7)	3-8
Other settings	3-8
TERMINATION UNIT NTU-7C8 CONFIGURATION	3-9
Physical Installation (IMDER01)	3-9
Physical Installation (NTU-7C8)	3-10
WIRING CONNECTIONS AND CABLING	3-11
Wiring	3-11
Cable Connections	3-11
Connecting Termination Cable to MMU Backplane	3-11
FUSING	3-11
PRE-OPERATING ADJUSTMENTS	3-11

---

## Table of Contents (continued)

	<b>Page</b>
<b>SECTION 4 - OPERATING PROCEDURES</b> . . . . .	<b>4-1</b>
INTRODUCTION . . . . .	4-1
INDICATORS . . . . .	4-1
START-UP PROCEDURES . . . . .	4-1
<b>SECTION 5 - TROUBLESHOOTING</b> . . . . .	<b>5-1</b>
INTRODUCTION . . . . .	5-1
ERROR INDICATION AND CORRECTIVE ACTION . . . . .	5-1
MASTER MODULE ERRORS . . . . .	5-1
LED indications . . . . .	5-2
MODULE PIN CONNECTIONS . . . . .	5-3
<b>SECTION 6 - MAINTENANCE</b> . . . . .	<b>6-1</b>
INTRODUCTION . . . . .	6-1
MAINTENANCE SCHEDULE . . . . .	6-1
<b>SECTION 7 - REPAIR/REPLACEMENT PROCEDURES</b> . . . . .	<b>7-1</b>
INTRODUCTION . . . . .	7-1
MODULE REPAIR/REPLACEMENT . . . . .	7-1
<b>SECTION 8 - SUPPORT SERVICES</b> . . . . .	<b>8-1</b>
INTRODUCTION . . . . .	8-1
REPLACEMENT PART AND ORDERING INFORMATION . . . . .	8-1
TRAINING . . . . .	8-1
TECHNICAL DOCUMENTATION . . . . .	8-1
<b>APPENDIX A - TERMINATION UNIT CONFIGURATION</b> . . . . .	<b>A-1</b>
INTRODUCTION . . . . .	A-1
TERMINATION UNIT (NTU-7C8) CONFIGURATION . . . . .	A-1

## List of Figures

No.	Title	Page
1-1.	IMDER01 Module in Actuator Control Unit . . . . .	1-2
2-1.	IMDER01 Module Block Diagram . . . . .	2-2
2-2.	NTU-7C8 Block Diagram . . . . .	2-3
2-3.	IMDER01 Digital Input Circuit . . . . .	2-4
2-4.	IMDER01 Digital Output Circuit . . . . .	2-5
3-1.	IMDER01 Module . . . . .	3-2
3-2.	Switch SW2 Settings . . . . .	3-3
3-3.	IMDER01 Cable Connection and Termination . . . . .	3-11
4-1.	IMDER01 Front Panel . . . . .	4-1
A-1.	Cable Connections for NTU-7C8 . . . . .	A-1
A-2.	FJB-789 Components Location . . . . .	A-2
A-3.	FIR-789 Connector and jumpers arrangements . . . . .	A-3

## List of Tables

No.	Title	Page
3-1.	Address Switch Settings (SW2) . . . . .	3-3
3-2.	Single Addressing Mode Jumper Settings . . . . .	3-4
3-3.	Address Switch Settings (SW2) . . . . .	3-5
3-4.	Dual (contiguous) Addressing Mode Jumper Settings . . . . .	3-5
3-5.	Address Switch Settings (SW2) . . . . .	3-6
3-6.	Dual (not contiguous) Addressing Mode Jumper Settings . . . . .	3-7
3-7.	Jumper E4 Configuration . . . . .	3-7
3-8.	Default Switch (SW1) Configuration Examples . . . . .	3-8
3-9.	Jumper E7 Configuration . . . . .	3-8
5-1.	Termination Unit Power Supplies Signalling LEDs . . . . .	5-2
5-2.	Power connector Pin Assignments . . . . .	5-3
5-3.	P2 Expander Bus Connector Pin Assignments . . . . .	5-3
5-4.	P3 Digital I/O Signal Connector Pin Assignments . . . . .	5-4
6-1.	Maintenance Schedule . . . . .	6-1
A-1.	NTU-7C8 Terminal Block Assignments . . . . .	A-4
A-2.	Connector Terminal Assignments . . . . .	A-5
A-3.	Jumper Settings for NTU-7C8 Digital Inputs . . . . .	A-6
A-4.	Digital Input Jumpers Settings . . . . .	A-8

## Safety Summary

**GENERAL  
WARNINGS****Equipment Environment**

All components, whether in transportation, operation or storage, must be in a non-corrosive environment.

**Electrical Shock Hazard During Maintenance**

Disconnect power or take precautions to ensure that contact with energized parts is avoided when servicing.

**SPECIFIC  
CAUTION**

We strongly recommend that you turn off cabinet power before doing any termination module wiring. Failure to do so could result in equipment damage. Do not apply power until you verify all wire connections. (p. 2-3)

## Sommaire de Sécurité

**AVERTISSEMENT  
D'ORDRE  
GÉNÉRAL****Environnement de l'équipement**

Ne pas soumettre les composants à une atmosphère corrosive lors du transport, de l'entreposage ou de l'utilisation.

**Risques de chocs électriques lors de l'entretien.**

S'assurer de débrancher l'alimentation ou de prendre les précautions nécessaires à éviter tout contact avec des composants sous tension lors de l'entretien.

**ATTENTION  
D'ORDRE  
SPÉCIFIQUE**

Il est fortement recommandé de débrancher l'alimentation électrique du cabinet avant d'effectuer toute connexion aux cartes de raccordement des modules. Des dommages aux équipements pourraient survenir dans le cas contraire. Ne pas rebrancher l'alimentation avant que toutes les connexions aient été vérifiées. (p. 2-3)

---

# SECTION 1 - INTRODUCTION

---

## OVERVIEW

The IMDER01 and the relevant NTU-7C8 termination unit are especially designed to implement "Single Drive I/O" interfaces for ON/OFF final actuators and relevant mosaic tiles handling.

It interfaces process inputs/outputs to a Multi-Function Processor. The IMDER01 and the NTU-7C8 are able to read 16 digital inputs and generate 8 digital outputs.

The digital inputs are typically used to receive operator commands from the control desk panel and to read feedback signals from the actuator contacts, the outputs can drive signalling LEDs on the control desk tiles and issue ON/OFF commands to the final control devices via power relays mounted on the NTU-7C8. Master modules provide control functions; slave module and termination units provide the I/O to the master modules.

This manual explains the purpose, operation and maintenance of the Digital Exchange Repeater (DER) module. It address handling precautions and installation procedures. Figure 1-1 illustrates the INFI 90 communication levels and the position of the DER module within these levels.

---

## INTENDED USER

System engineers and technicians should read this manual before installing and operating the DER module. A module SHOULD NOT be put into operation until this instruction is read and understood. You can refer to the Table of Contents to find specific information after the module is operating.

---

## MODULE DESCRIPTION

The IMDER01 module consists of a single printed circuit board that occupies one slot in a Module Mounting Unit (MMU). It monitors 16 digital inputs and drives 8 digital outputs.

Two captive screws on the module faceplate secure it to the MMU. Sixteen front panel LED status indicators display input status, eight front panel LED status indicators display output status.

The slave module has three card edge connectors for external signals and power (P1, P2 and P3). P1 connects to common (ground) and  $\pm 5$  VDC power (refer to Table 5-2). P2 connects the module to the Slave Expander Bus to communicate with a master module (refer to Table 5-3). The digital I/O signals are exchanged through connector P3 using a cable connected to a Termination Unit (T.U.) or Termination Module (T.M.) (refer to Table 5-4). The terminal blocks (physical connection points) for field wiring are on the T.U./T.M.

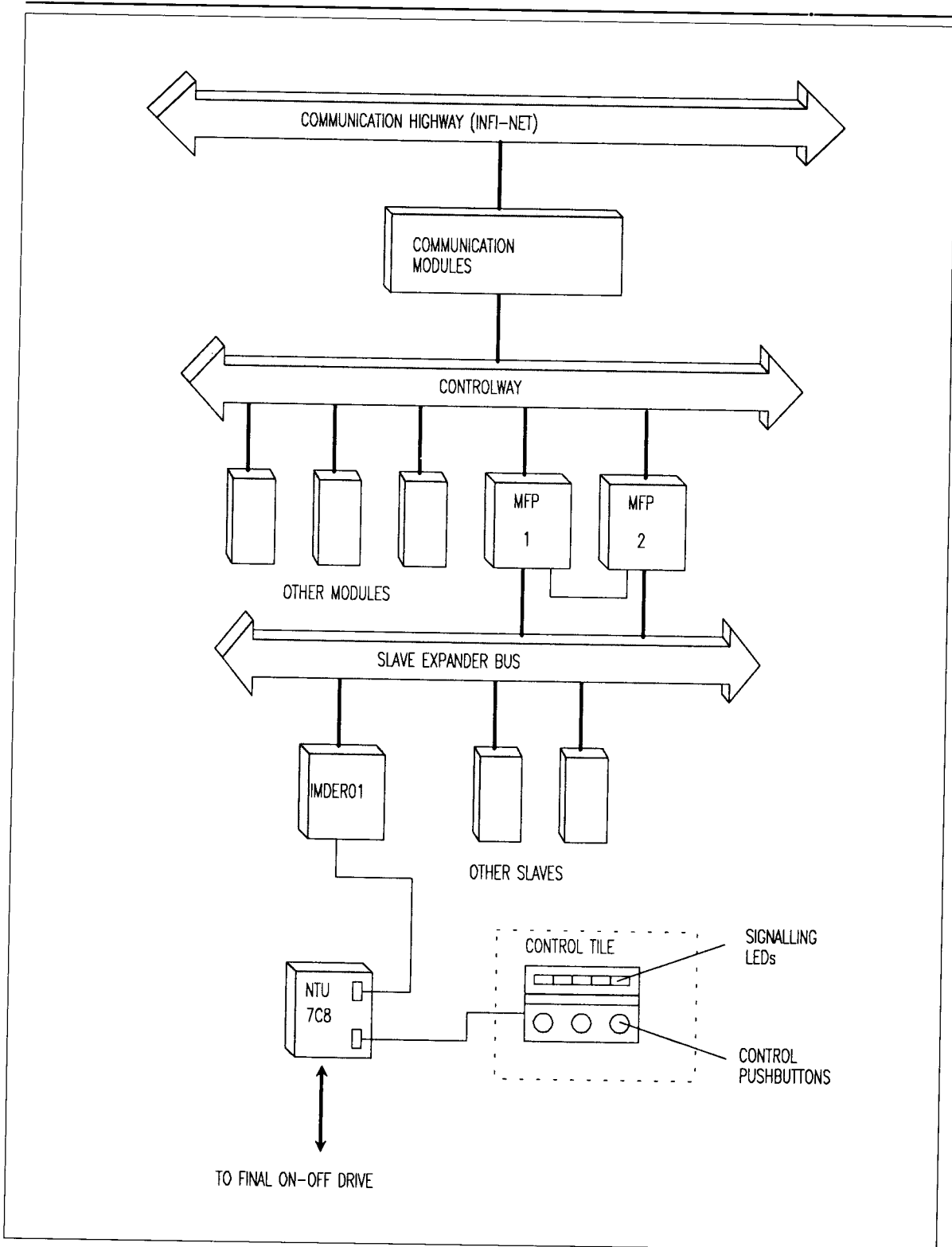

Figure 1-1. IMDER01 Module in Actuator Control Unit.

MODULE DESCRIPTION

---

**FEATURES**

The modular design of the DER module, as with all INFI 90 modules, allows for flexibility in creating a process management strategy. It brings sixteen separate digital signals into the system and bring eight separate digital signals out of the system.

Input, output and system circuitry are all mutually isolated. Selectable response times for DC inputs allow the INFI 90 system to compensate for process field device debounce time.

The front panel LED status indicators provide a visual indication of the input and output states to aid in system tests and diagnostics. Further module status is provided by the green/red LED visible through the module's front panel.

A DER module can be removed or installed without powering the system down.

---

**INSTRUCTION CONTENT**

This manual consists of eight sections. Introduction is an overview of the DER module: Features, description and specifications. Description and Operation explains the module operation and input circuitry. Installation describes precautions to observe when handling DER modules and set-up procedures required before module operation. It also discusses switches, jumpers and dipshunts settings and installation procedures.

Operating Procedures explains the front panel indicators and startup of the slave module. Troubleshooting describes the error indications and corrective actions to be taken.

Maintenance has a maintenance schedule for the slave module.

Repair/Replacement Procedures details the procedures to replace a module. Support Services provides replacement part ordering information. It explains other areas of support that Elsag Bailey provides.

---

**HOW TO USE THIS MANUAL**

Read this manual through in sequence. It is important to become familiar with the entire contents of this manual before using the IMSER01. The manual is organized in sections to enable you to find specific information quickly.

1. Read and do the steps in the **Installation** section.
2. Read the **Operating Procedures** section before powering up the module.
3. Refer to the **Troubleshooting** section if a problem occurs.
4. Refer to the **Maintenance** section for scheduled maintenance requirements.
5. Refer to the **Repair/Replacement Procedures** section for how to replace a module.
6. Use the **Support Services** section when ordering replacement parts.

---

**FEATURES**

---

**REFERENCE DOCUMENTS**

Document Number	Document
I-E96-201	Multi_Function Processor (IIMMFP01)
I-E96-202	Multi_Function Processor (IMMFP02)
I-E96-209	Logic Master Module (IMLMM02)
I-E93-911	Termination Unit Manual
I-E96-110	Operator Interface Station
I-E93-916	Engineering Work Station
E-96-200A	Function Code Application Manual
I-E92-501-2	Configuration and Tuning Terminal

---

**NOMENCLATURE**

The following modules and equipment can be used with an IMDER01 module:

Nomenclature	Hardware
IMMFP01	Multi-Function Processor Module
NTU-7C8	Termination Unit, Single Drive I/O
xKTU01	Cable, termination Unit
INSEM	Sequence of events system
IMUSM	Universal Simulation Module

**GLOSSARY OF TERMS AND ABBREVIATIONS**

<b>Term</b>	<b>Definition</b>
<b>Configuration</b>	A control strategy with function blocks.
<b>Controlway</b>	A redundant peer-to-peer communication path for point to point data transfer between intelligent modules within a process control unit
<b>Digital</b>	A discrete input signal having only two states: on or off.
<b>Dipshunt</b>	Dual in-line package with shorting bars
<b>Dipswitch</b>	A dual in-line package that contains single pole switches.
<b>EWS</b>	Engineering Work Station; an integrated hardware and software personal computer system for configuring and monitoring INFI 90 modules and systems.
<b>Function Code</b>	An algorithm that defines specific functions. These functions link together to form the control strategy.
<b>LED</b>	Light Emitting Diode; the module front panel indicator that shows status and error messages.
<b>LSB</b>	Least Significant Bit; the bit of a binary number that carries the least numerical weight.
<b>Master Module</b>	One of a series of controller modules designed to direct field processes through a slave module. The multi-function processor is an example.
<b>MFP</b>	Multi-Function Processor Module; a multiple-loop controller with data acquisition and information processing capabilities.
<b>MMU</b>	Module Mounting Unit; a card cage that provides electrical and communication support for INFI 90 modules.
<b>MSB</b>	Most Significant Bit; the bit of a binary number that carries the most numerical weight.
<b>OIS</b>	Operator Interface Station; integrated operator console with data acquisition and reporting capabilities. It provides a window into the process for flexible control and monitoring.
<b>PCU</b>	Process Control Unit; rack type industrial Cabinet that contains master, slave and communication modules, and their communication paths.
<b>Slave Expander Bus</b>	Parallel address/data bus between the master module and the slave.
<b>T.M.</b>	Termination Module: provides input/output connection between plant equipment and the INFI 90 process modules. The termination module slides into a slot in the termination mounting unit.
<b>T.U.</b>	Termination Unit; provides input/output connection between plant equipment and the INFI 90 process modules. The termination unit is a flat circuit board for panel mounting.
<b>Jumper</b>	Package with shorting bar.

**SPECIFICATIONS**

<b>Logic Power (IMDER01 only)</b>		
Supply Voltage	± 5 VDC (± 5%)	
Current Consumption	80 mA @ + 5 VDC (typical)	
<b>Digital Inputs (1 to 12) <sup>2</sup></b>		
Voltages	24 VDC (± 10%) 48 VDC (±10%) 110/125 VDC (±10%) 120/127 VAC (±10%) 220 VAC (±10%) <b>Digital Input 7 only</b>	
Input current (typical)	4.9 mA @ 24 VDC 5.1 mA @ 48 VDC 5.1 mA @ 48 VDC 5.8 mA @ 110 VDC 6.7 mA @ 125 VDC 6.5 mA @ 120 VAC 8.2 mA @ 220 VAC <b>Digital Input 7 only</b>	
Turn-On Voltage (minimum)	24 VDC 48 VDC 110/125 VDC 120/127 VAC 220 VAC	14.7 VDC 32.2 VDC 68.4 VDC 53.8 VAC 107.8 VAC <b>Digital Input 7 only</b>
Turn-On Voltage (maximum)	24 VDC 48 VDC 110/125 VDC 120/127 VAC 220 VAC	13.2 VDC 28.7 VDC 57.9 VDC 47.8 VAC 99.6 VAC <b>Digital Input 7 only</b>
Maximum Input Current at Minimum Turn-on	24 VDC 48 VDC 110/125 VDC 120/127 VAC 220 VAC	3.53 mA @ 14.7 VDC 3.5 mA @ 32.2 VDC 3.56 mA @ 68.4 VDC 3.0 mA @ 53.8 VAC 3.57 mA @ 107.8 VAC <b>Digital Input 7 only</b>
<b>Digital Inputs (13 to 16) <sup>2</sup></b>		
Voltages	24 VDC (± 10%) 48 VDC (±10%)	
Input Current (typical)	3.00 mA @ 24 VDC 3.12 mA @ 48 VDC	
Turn-On Voltage (minimum)	24 VDC 48 VDC	14.7 VDC 32.2 VDC
Turn-On Voltage (maximum)	24 VDC 48 VDC	11.9 VDC 22.8 VDC
Maximum Input Current at Minimum Turn-on	24 VDC 48 VDC	1.82 mA @ 14.7 VDC 1.82 mA @ 28.3 VDC
<b>Digital Outputs (4 to 8) <sup>2</sup></b>		
Typology	Open Collector	
Voltages	from 24 VDC to 48 VDC (no configuration required)	
Output Current (maximum)	320 mA	
<b>Digital Outputs (1 and 2) <sup>2</sup></b>		
Typology	Relay Contacts	
Normally Open Contacts		

**SPECIFICATIONS (continued)**

Voltage (up to)	220 VAC	
Current (max.)	10 Arms	
Switching Capacity (cosphi 0,4)	4 A @ 110 VAC	----
Switching Capacity (L/R = 10ms)	----	1A @ 110 VDC
Life Expectancy (operation)	2.5x10 <sup>5</sup>	1x10 <sup>5</sup>
Open Contact Dielectric Strength	2kV (1 second)	
<b>Normally Closed Contacts</b>		
Voltage (up to)	220 VAC	
Current (max.)	10 Arms	
Switching Capacity (cosphi 0,4)	4 A @ 110 VAC	----
Switching Capacity (L/R = 10ms)	----	0.25A @ 110 VDC
Life Expectancy	2.5x10 <sup>5</sup>	1x10 <sup>5</sup>
Open Contact Dielectric Strength	1kV (1 second)	
<b>Digital Outputs (3) <sup>2</sup></b>		
Typology	Relay Contacts	
Both Normally Open and Normally Closed Contacts		
Voltage (up to)	220 VAC	
Current (max.)	8 Arms	
Switching Capacity (cosphi 0,4)	1 A @ 110 VAC	----
Switching Capacity (L/R = 10mS)	----	0.5A @ 110 VDC
Life Expectancy (operation)	2.5x10 <sup>5</sup>	1x10 <sup>5</sup>
Open Contact Dielectric Strength	1kV (1 second)	
<b>Communication Interface (IMDER01 only)</b>		
Passive contact input interface and outputs read/write the Multi-Function Processor or Logic Master Module via Slave Expander Bus		
<b>Isolation (As for IEC255-5):</b>		
	Common mode	Normal mode
Pulse Voltage Test (1.2/50µs) (as for IEC801-5)	2kVp	1kVp
Line Frequency wave (50Hz)	50 Vp	
Low Voltage Wave Train (sweep from 1kHz to 1 MHz)	100 Vp	10 Vp
Damped 1 MHz Oscillatory Wave 1 kVp (as for IEEE-472)	0.5 kVp	
Damped 100 kHz Oscillatory Wave (as for IEEE-472)	0.5 kVp	0.2 kVp
Electrical Fast Transient/Burst 1 kVp (as for IEC 801-4)	1 kVp	
Radio frequency interferences	No value available at this time. Keep cabinet door closed. Do not use communication equipments closer than 2 mt. from cabinet.	
<b>Environmental Specifications</b>		
Ambient Temperature	0° to +70°C (32° to 158° F)	
Relative Humidity	5% to 95% up to 55°C (131° F) (non condensing)	
Atmospheric Pressure	Sea level to 3 km (1.86 miles)	
Air Quality	Non corrosive	
<b>Mounting</b>		
IMDER01 occupies one slot in a standard INFI 90 Module Mounting Unit (MMU) NTU-7C8 is screw Mounted On The Field Termination Panel (NFTP01)		

**SPECIFICATION SUBJECT TO CHANGE WITHOUT NOTICE**

- <sup>1</sup> Isolation measured at sea level. All inputs and outputs isolated if isolated power supplies are used.  
<sup>2</sup> Referred to Single Drive System (IMDER01 and NTU-7C8 together)



---

## SECTION 2 - DESCRIPTION AND OPERATION

### **INTRODUCTION**

This section describes the digital input circuitry, control logic, logic power and connections for the Digital Exchange Repeater (IMDER01) module. The IMDER01 is a digital input/output interface to a Multi-Function Processor (MFP). The master module provides the control functions. A Master module communicates with its slave modules over a 12-line Slave Expander Bus as shown in Figure 1-1.

Each slave on the Slave Expander Bus has an address set by its slave address dipswitch (SW2) (see Figure 2-1).

The following description is referred to the "Single Drive Unit", that is the characteristic coming from the IMDER01 plus the T.U. NTU-7C8.

---

### **INPUTS**

The digital inputs are of the passive type. Closed contacts are detected by the input circuitry as energized (ON) field devices; open contacts are detected as de-energized (OFF) field devices. The IMDER01 has filter for contacts debounce.

---

### **Input Circuits**

Figure 2-1 shows the IMDER01 in block diagram form to illustrate signal flow through the module. The input isolation block consists of input transient voltage protection and optocouplers to isolate the sixteen field inputs from the module circuitry.

The threshold detection block circuits test the input voltage to determine if it is at a proper voltage level to indicate an ON or OFF state. The output of this comparator is sent to a read buffer in the control logic block (the threshold of this comparator is specified in the INTRODUCTION section). If an input is energized (ON), it also causes the corresponding input status LED on the front panel to light.

The control logic block consists of buffers that hold the input and status byte values. The Slave Expander Bus interface allows the master module to read these bytes.

Figure 2-1. IMDER01 Module Block Diagram

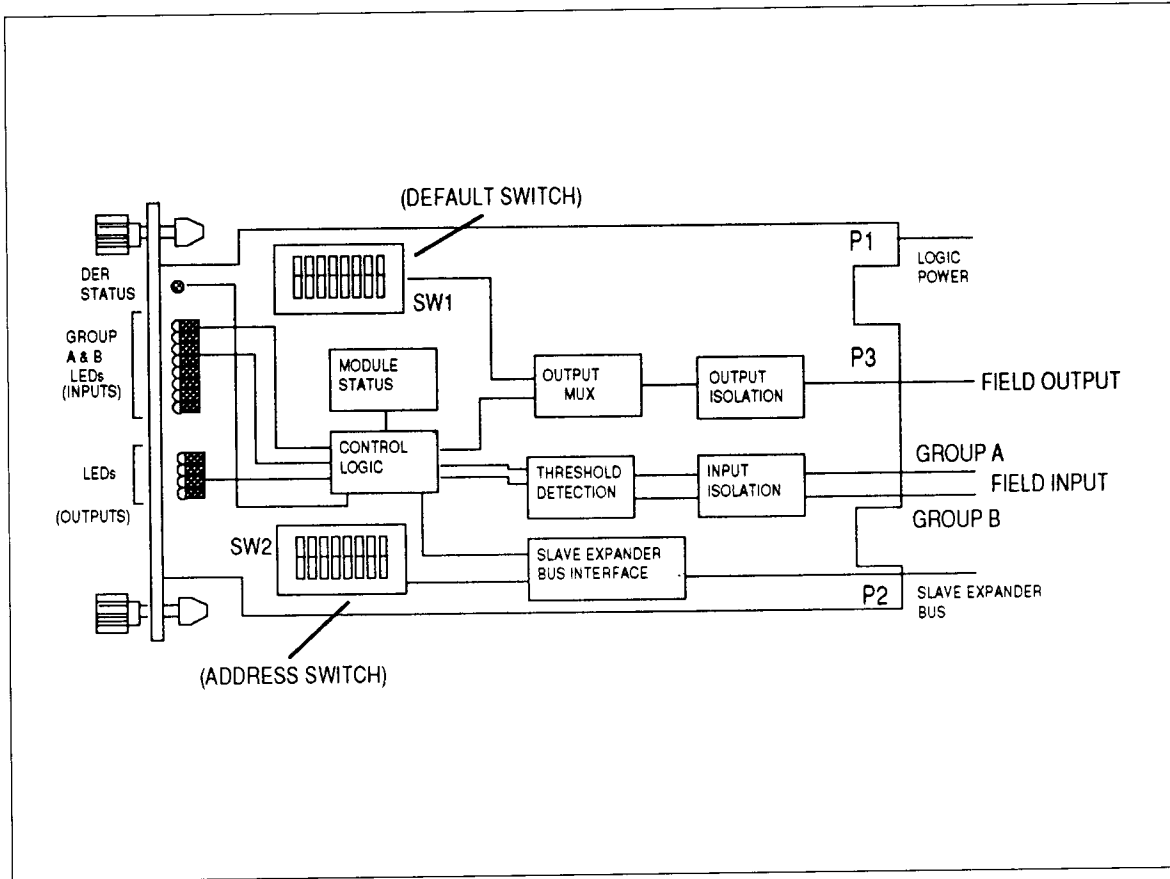

**Input Circuit Description (On IMDER01)**

When the contact detected by the digital input is closed, the optocoupler diode (OC) conducts. The output of the optocoupler goes high (+5 V), causing the output of the comparator (STC) to go to logic "0". The LED corresponding to this input lights to indicate that a closed contact (ON) has been detected. The Slave Expander Bus interface transmits a logic "1" to the master module over the Slave Expander Bus.

When the contact detected by the digital input is open, current does not flow in the optocoupler diode (OC). The output of the optocoupler remains low (0 V), causing the output of the comparator (STC) to go to logic "1". The LED corresponding to this input stays off to indicate that an open contact (OFF) has been detected. The slave expander bus interface transmits a logic "0" to the master module over the Slave Expander Bus.

To configure the digital inputs refer to the Installation section in this instruction.

Figure 2-3 shows the digital input circuitry.

This circuits are on the IMDER01 and are the circuits used to input the tile pushbuttons status.

Fig. 2-2 shows the T.U. block diagram. As can be seen, the field inputs have an additional input circuit, including isolation, on the T.U.

The three power outputs have the relays on the T.U.

Figure 2-2. NTU-7C8 Block Diagram

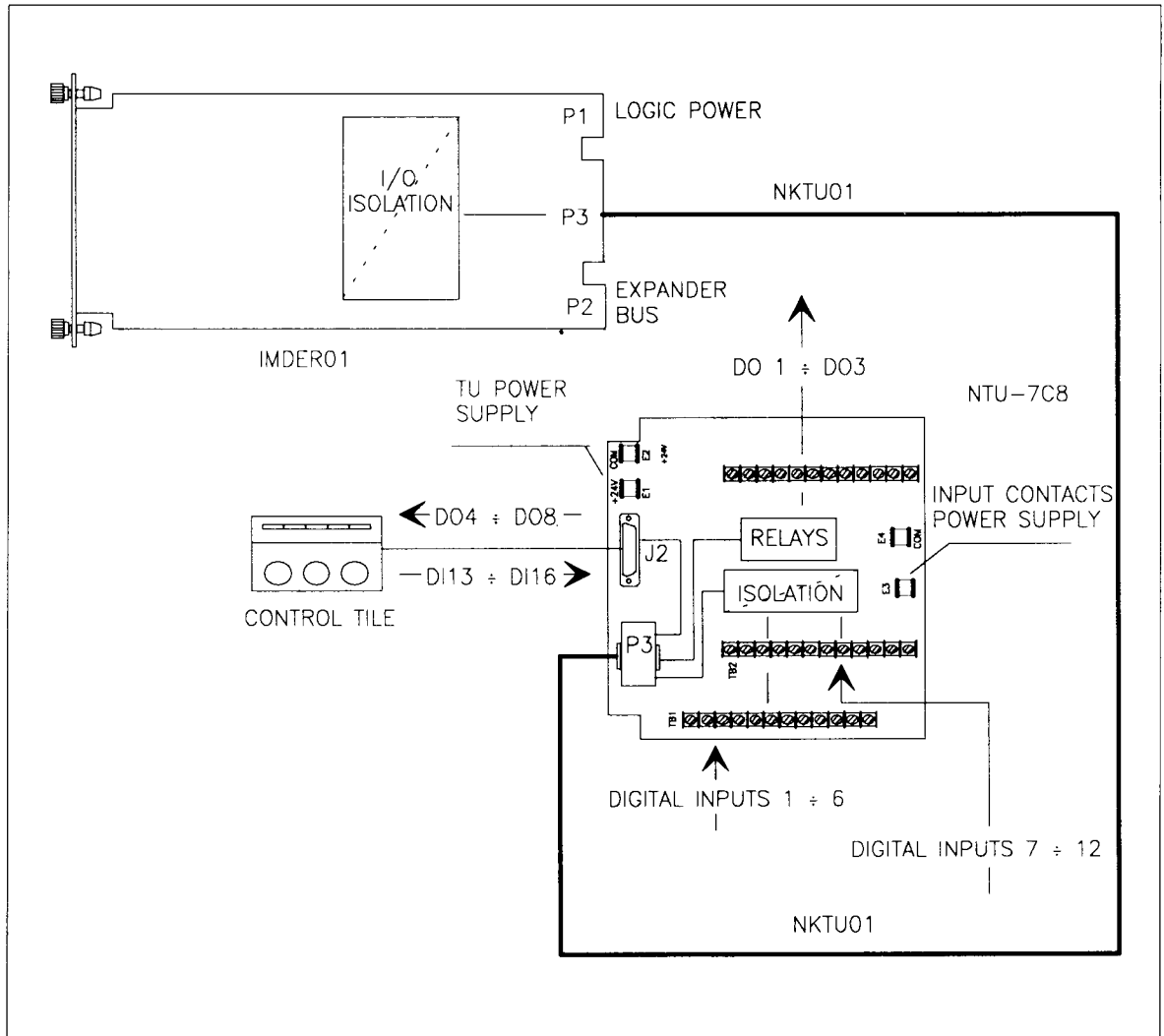

The 12 field inputs have a similar circuit on the T.U., which output is connected to the circuit on the IMDER01, that is these 12 inputs are double isolated.

The main difference between the input circuits on the IMDER01 and those on the NTU-7C9 is that the latter can be configured for different contact power voltage, whereas the former are powered at 24 VDC. The field inputs are DI 1-DI 12, whereas the tile inputs are DI 13-DI 16.

The inputs characteristics are listed into the "SPECIFICATIONS".

Figure 2-3. IMDER01 Digital Input Circuit.

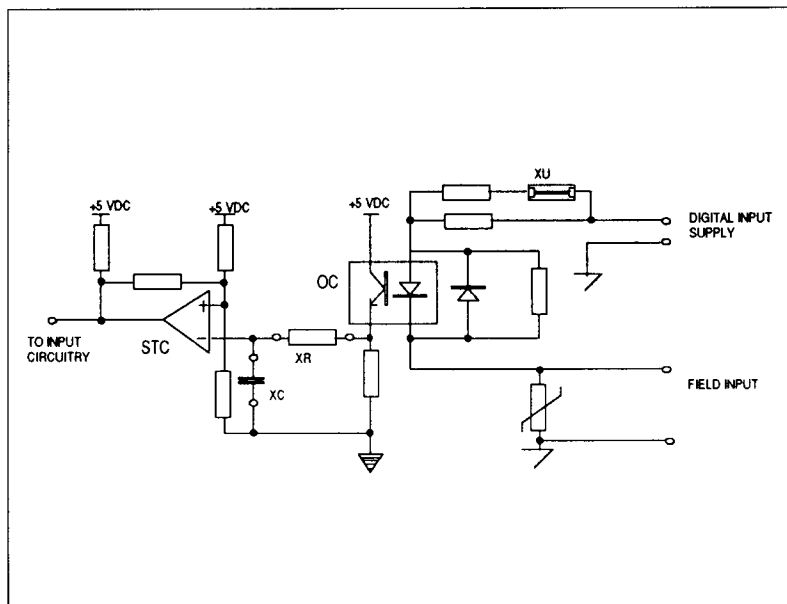

## OUTPUTS

The IMDER01 module can drive 8 digital outputs.

### Output Circuits

Figure 2-1 shows the IMDER01 in block diagram form to illustrate signal flow through the module whereas figure 2-2 shows an NTU-7C9 block diagram. The output isolation blocks consists of current limiters and optocouplers to isolate the eight field outputs from the module circuitry.

If there is a communications failure with the master module, the output multiplexer (OUTPUT MUX) enables the digital outputs to be forced high or low according to dipswitch SW1 settings (DEFAULT SWITCH). The outputs can also be maintained at the level most recently written by the master module if this option is selected on the same dipswitch SW1.

If an output is activated, the corresponding output status LED on the front panel lights.

The control logic block comprises a register containing the status of the digital outputs written periodically by the master module. The master module writes to the register over the Slave Expander Bus. If there is a communication failure with the master module (detected by the slave expander bus interface), the control logic block enables the outputs to be maintained at the last value written or to be forced to the default value (DEFAULT SWITCH) by driving the output multiplexer.

## OUTPUTS

### Output Circuit Description

Refer to figure 2-4.

When the master module activates an output, the corresponding output multiplexer output goes to logic "0". This causes the optocoupler diode (OC) to conduct and its output to go low, allowing current to flow at the base of the output transistor (Q1).

The output transistor (Q1) is saturated (ON), so delivering the power supply to the load connected to the output.

When the master module de-activates an output, the corresponding output multiplexer output goes high. No current flows through the optocoupler diode. This causes the optocoupler (OC) output to go high, cutting off the current to the base of the output transistor (Q1).

The output transistor (Q1) cuts out, removing the power supply from the load connected to the output.

The three cascade connected diodes (CR1, CR2, CR3), resistor R1 and thermistor PTC make up the output current limiting circuit. The varistor R2 provides protection against transient voltages (spikes).

The outputs DO4-DO8 are used to drive LEDs on the passive tile and go through the NTU-7C9 directly to the tile. The power outputs DO1-DO3 go to the field device through three relays housed on the T.U.

The output characteristics are listed into the "SPECIFICATIONS".

Figure 2-4. IMDER01 Digital Output Circuit

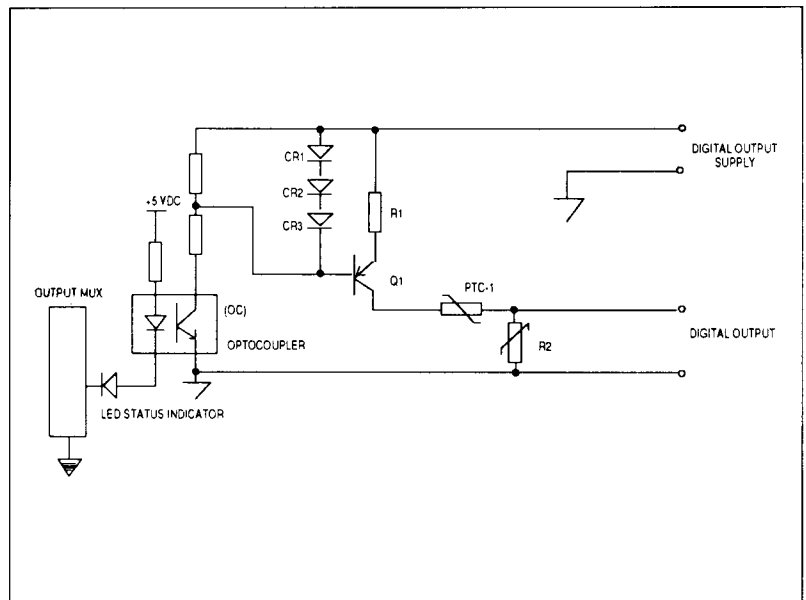

OUTPUTS

---

**I/O Circuit Connections**

The power supplies for the input and output circuits can be at different voltages. The two power supplies use a common ground. The contact input and output signals connect to the 30-pin card edge connector (P3), shown in figure 2-1, using a termination cable from a termination unit or module.

---

**CONTROL LOGIC**

Function Code 84 in the master module configuration accesses the IMDER01 over the Slave Expander Bus. It also allows the master module to automatically read point (input) data or status data from the IMDER01.

This data is output by the buffer circuits (control logic) to the slave expander bus interface (see figure 2-1).

Function Code 83 in the master module configuration accesses the IMDER01 over the slave expander bus to write to digital outputs. It also allows the master module to automatically write point (output) data or read status data to/from the IMDER01. This data is output by the buffer circuits (control logic) to the slave expander bus interface (read status) or written to the data output register (control logic) by the slave expander bus (see figure 2-1).

The IMDER01 module can be set for three different addressing modes:

- Single addressing mode: Function Code 83 and 84 configured with the same address.
- Dual (contiguous) addressing mode: Function Code 83 and 84 configured with contiguous addresses (e.g. F.C. 84 Specification S1 = 04. F.C. 83 Specification S1 = 05), occupying two addresses on the expander bus.
- Dual (not contiguous) addressing mode: Function Code 83 and 84 configured with the different non-contiguous addresses with a displacement of 64 (e.g. F.C. 84 Specification S1 = 04. F.C. 83 Specification S1 = 68), occupying two addresses on the expander bus.

For further information on addressing modes, refer to the Installation section of this instruction.

The F.C. 83 must be configured as for driving an IMDSO04, that is: S2 = 010.

---

**I/O Point Data Byte**

Input point data is two 8-bit bytes. Each byte corresponds to group A or group B inputs. Each bit of data represents one input. The bit value reflects the state of that input, either open (logic "0") or closed (logic "1").

Output Point data is one 8-bit byte. This byte corresponds to group A outputs. Each bit of data represents one output. The bit value is the state of that output, either open (logic "0", de-energized output) or closed (logic "1", energized output).

---

**CONTROL LOGIC**

**Status Byte**

The status byte ensures module integrity. It makes sure slave expander bus communication are correct. The master module reads the status byte and compares it to an expected value. If there is a mismatch, it flags the error and marks the point as bad quality (for digital inputs - F.C. 84) or flags the error by setting the output of the block relative to Function Code 83 (Group Status)) to logic "1".

---

**LOGIC POWER**

Logic Power (+5 VDC) drives the IMDER01 circuits. It connects through the top 12 pin card edge connector (P1) shown in figure 2-1.

---

**SLAVE EXPANDER BUS**

The INFI 90 Slave Expander Bus is a high speed synchronous parallel bus. It provides a communication path between master module and slave modules. The master module provides the control functions and the IMDER01 module provides input/output to/from the master module. The IMDER01 and master module P2 card edge connectors connect to the bus.

The Slave Expander Bus is twelve signal lines located on the Module Mounting Unit (MMU) back plane. A 12-strap dipshunt placed in a connection socket on the MMU backplane connects the bus between the master and slave modules. Cable assemblies can extend the bus up to six MMUs.

A master module and its slaves form an individual subsystem within a Process Control Unit (PCU). The Slave Expander Bus between master/slave subsystems must be separated. Leaving a dipshunt socket empty or not connecting the MMUs with cables separates them.

---

**UNIVERSAL SLAVE EXPANDER BUS INTERFACE**

The IMDER01 uses a custom gate array to perform the slave expander bus interface function. All control logic and the communication protocol is built into an integrated circuit (IC). This IC provides the following functions:

- Address comparison and detection
- Function Code latching and decoding
- read and write strobe generation
- Data line filtering of bus signals
- On-board bus drivers

LOGIC POWER

---



---

## SECTION 3 - INSTALLATION

---

### **INTRODUCTION**

This section explains what you must do before you put the IMDER01 module into operation. **DO NOT PROCEED** with operation until you read, understand and perform the steps in order in which they appear.

**NOTE:** Refer to the Appendix A for NTU-7C8 wiring instructions.

---

### **SPECIAL HANDLING**

**NOTE:** Always use Bailey's Field Static Kit (P/N 1948385A2 - consists of wrist strap, ground cord assembly, alligator clip) when working with modules. The kit is designed to connect a technician and the static dissipative work surface to the same ground point to prevent damage to the modules by electrostatic discharge.

The IMDER01 module uses electrostatic sensitive devices. Follow Steps 1 through 4 when handling:

1. Keep the module in its special anti-static bag until you are ready to install it in the system. Save the bag for future use.
  2. Ground the anti-static bag before opening.
  3. Verify that all devices connected to the module are properly grounded before using them.
  4. Avoid touching the circuitry when handling the module.
- 

### **UNPACKING AND INSPECTION**

1. Examine the hardware immediately to verify it has not been damaged in transit.
2. Notify the nearest Elsag Bailey Sale Office of any such damage.
3. File a claim for any damage with the transportation company that handled the shipment.
4. Use the original packing material and container to store the hardware.
5. Store the hardware in an environment of good quality, free from temperature and moisture extremes.

INTRODUCTION

---

**IMDER01 Configuration**

Prior to installation, you must set the address of the IMDER01, install jumpers to configure addressing mode and the action taken by control logic on loss of master, set the dipshunts to configure Digital input supply voltage and configure the propagation time (speed) of digital inputs by setting the appropriate resistor value.

**Slave Address Selection (SW2, E1, E2, E3, E5, E6, E8)**

The IMDER01 module is provided with three possible addressing modes:

- Single addressing mode
- Dual a(contiguous) addressing mode
- Dual (not contiguous) addressing mode

**Single addressing mode**

This mode enables a single address to be used for Function Codes 84 and 83. The IMDER01 module can be set to one of the 64 addresses (0 to 63) on the slave expander bus. This address uniquely identifies the slave to the master module and must be the same as the address set in the master module configuration (Function Code 84 specification S1 and Function Code 83 specification S1).

The address is set by an eight pole address switch (SW2) shown in Figure 3-1. The six rightmost poles position (3 through 8) of SW2 set the six bit IMDER01 address. Poles 1 and 2 are not used and must remain in the closed position (see Figure 3-2). Table 3-1 is a binary address conversion table for setting SW2. Table 3-2 contains jumper settings for this configuration.

*Figure 3-1. IMDER01 Module*

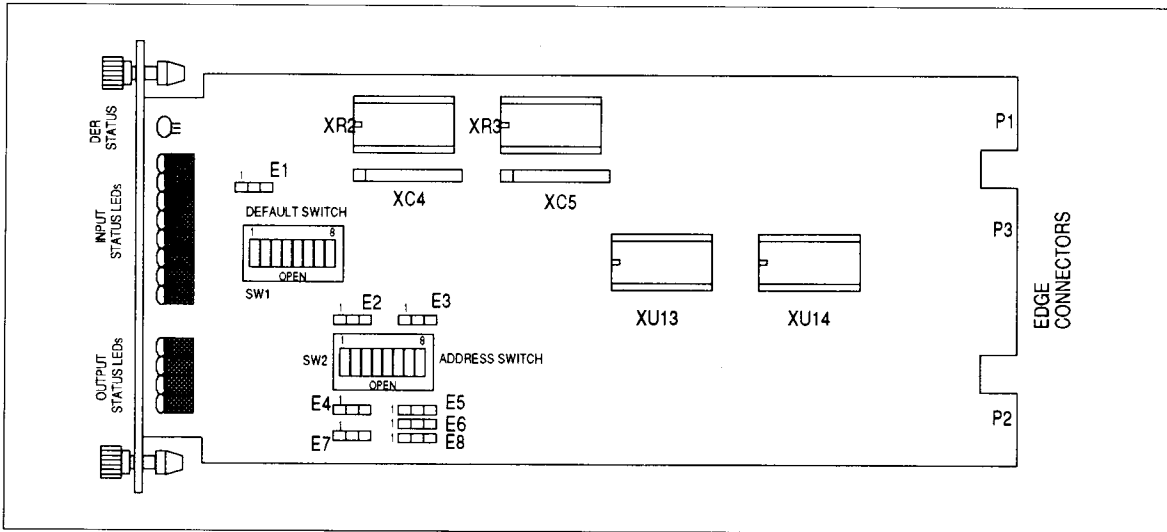

UNPACKING AND INSPECTION

Figure 3-2. Switch SW2 Settings

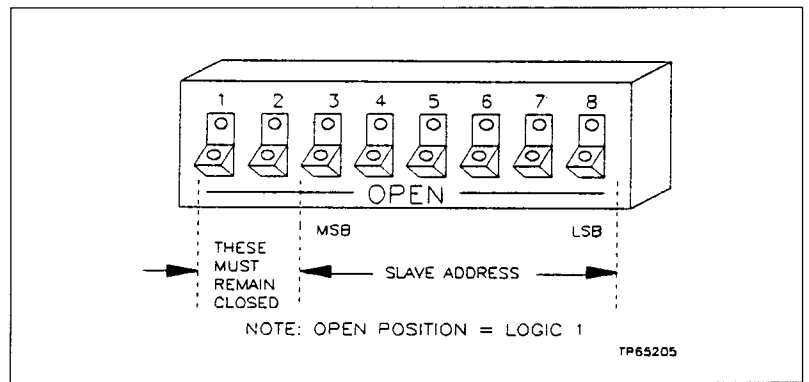

Table 3-1. Address Switch Settings (SW2)

3	4	5	6	7	8	Addr.	3	4	5	6	7	8	Addr.
0	0	0	0	0	0	00	1	0	0	0	0	0	32
0	0	0	0	0	1	01	1	0	0	0	0	1	33
0	0	0	0	1	0	02	1	0	0	0	1	0	34
0	0	0	0	1	1	03	1	0	0	0	1	1	35
0	0	0	1	0	0	04	1	0	0	1	0	0	36
0	0	0	1	0	1	05	1	0	0	1	0	1	37
0	0	0	1	1	0	06	1	0	0	1	1	0	38
0	0	0	1	1	1	07	1	0	0	1	1	1	39
0	0	1	0	0	0	08	1	0	1	0	0	0	40
0	0	1	0	0	1	09	1	0	1	0	0	1	41
0	0	1	0	1	0	10	1	0	1	0	1	0	42
0	0	1	0	1	1	11	1	0	1	0	1	1	43
0	0	1	1	0	0	12	1	0	1	1	0	0	44
0	0	1	1	0	1	13	1	0	1	1	0	1	45
0	0	1	1	1	0	14	1	0	1	1	1	0	46
0	0	1	1	1	1	15	1	0	1	1	1	1	47
0	1	0	0	0	0	16	1	1	0	0	0	0	48
0	1	0	0	0	1	17	1	1	0	0	0	1	49
0	1	0	0	1	0	18	1	1	0	0	1	0	50
0	1	0	0	1	1	19	1	1	0	0	1	1	51
0	1	0	1	0	0	20	1	1	0	1	0	0	52
0	1	0	1	0	1	21	1	1	0	1	0	1	53
0	1	0	1	1	0	22	1	1	0	1	1	0	54
0	1	0	1	1	1	23	1	1	0	1	1	1	55
0	1	1	0	0	0	24	1	1	1	0	0	0	56
0	1	1	0	0	1	25	1	1	1	0	0	1	57
0	1	1	0	1	0	26	1	1	1	0	1	0	58
0	1	1	0	1	1	27	1	1	1	0	1	1	59
0	1	1	1	0	0	28	1	1	1	1	0	0	60
0	1	1	1	0	1	29	1	1	1	1	0	1	61
0	1	1	1	1	0	30	1	1	1	1	1	0	62
0	1	1	1	1	1	31	1	1	1	1	1	1	63

NOTE: 1 = open; 0 = closed

*Table 3-2. Single Addressing Mode Jumper Settings*

Jumper	Position
E1	1 - 2
E2	2 - 3
E3	2 - 3
E5	1 - 2
E6	1 - 2
E8	Don't care

**Dual (contiguous) addressing mode**

This mode enables two next Expander Bus addresses to be used for the interface with the master module. One address is reserved for use by Function Code 84, and the other by Function Code 83. The IMDER01 module can use two of the 64 addresses (0 to 63) on the slave expander bus. The odd address is used by the digital output function (F.C. 83). The even address is used by the digital input function (F.C. 84).

The address is set by an eight pole address switch (SW2) shown in Figure 3-1.

The six rightmost poles (3 through 8) of SW2 set the six bit IMDER01 address. Poles 1 and 2 are not used and must remain in the closed position (see Figure 3-2).

In this configuration the least significant bit (LSB) of switch SW2 is don't care. Table 3-3 is a binary address conversion table for setting SW2. Table 3-4 contains jumper settings for dual contiguous addressing mode.

These addresses identify the slave to the master module and must be the same as the address set in the master module configuration (Function Code 84 specification S1 and Function Code 83 specification S1).

Table 3-3. Address Switch Settings (SW2)

3	4	5	6	7	8	DER Addr. FC 83	FC 84	3	4	5	6	7	8	DER Addr. FC 83	FC 84
0	0	0	0	0	X	00	01	1	0	0	0	0	X	32	33
0	0	0	0	1	X	02	03	1	0	0	0	1	X	34	35
0	0	0	1	0	X	04	05	1	0	0	1	0	X	36	37
0	0	0	1	1	X	06	07	1	0	0	1	1	X	38	39
0	0	1	0	0	X	08	09	1	0	1	0	0	X	40	41
0	0	1	0	1	X	10	11	1	0	1	0	1	X	42	43
0	0	1	1	0	X	12	13	1	0	1	1	0	X	44	45
0	0	1	1	1	X	14	15	1	0	1	1	1	X	46	47
0	1	0	0	0	X	16	17	1	1	0	0	0	X	48	49
0	1	0	0	1	X	18	19	1	1	0	0	1	X	50	51
0	1	0	1	0	X	20	21	1	1	0	1	0	X	52	53
0	1	0	1	1	X	22	23	1	1	0	1	1	X	54	55
0	1	1	0	0	X	24	25	1	1	1	0	0	X	56	57
0	1	1	0	1	X	26	27	1	1	1	0	1	X	58	59
0	1	1	1	0	X	28	29	1	1	1	1	0	X	60	61
0	1	1	1	1	X	30	31	1	1	1	1	1	X	62	63

NOTE: 1 = open; 0 = closed

Table 3-4. Dual (contiguous) Addressing Mode Jumper Settings

Jumper	Position
E1	2 - 3
E2	2 - 3
E3	1 - 2
E5	2 - 3
E6	2 - 3
E8	1 - 2

**Dual (not contiguous) Addressing Mode**

This mode allows one address to be used for Function Code 84 and another address for Function Code 83. The DER module can use one of the 64 addresses (0 to 63) on the Slave Expander Bus. This address is reserved for use by the digital input function (Function Code 84). The digital output function (Function Code 83) uses the address obtained by adding 64 to the digital input function address. Tables 3-5 and 3-6 show the jumper settings and address switch positions to use for this configuration.

**WARNING** The use of addresses above 63 may create address conflict if on the same Expander Bus either an IMSEM or an IMUSM system is used.

Table 3-5. Address Switch Settings (SW2)

3	4	5	6	7	8	DER Addr. FC 83	FC 84	3	4	5	6	7	8	DER Addr. FC 83	FC 84
0	0	0	0	0	0	00	64	1	0	0	0	0	0	32	96
0	0	0	0	0	1	01	65	1	0	0	0	0	1	33	97
0	0	0	0	1	0	02	66	1	0	0	0	1	0	34	98
0	0	0	0	1	1	03	67	1	0	0	0	1	1	35	99
0	0	0	1	0	0	04	68	1	0	0	1	0	0	36	100
0	0	0	1	0	1	05	69	1	0	0	1	0	1	37	101
0	0	0	1	1	0	06	70	1	0	0	1	1	0	38	102
0	0	0	1	1	1	07	71	1	0	0	1	1	1	39	103
0	0	1	0	0	0	08	72	1	0	1	0	0	0	40	104
0	0	1	0	0	1	09	73	1	0	1	0	0	1	41	105
0	0	1	0	1	0	10	74	1	0	1	0	1	0	42	106
0	0	1	0	1	1	11	75	1	0	1	0	1	1	43	107
0	0	1	1	0	0	12	76	1	0	1	1	0	0	44	108
0	0	1	1	0	1	13	77	1	0	1	1	0	1	45	109
0	0	1	1	1	0	14	78	1	0	1	1	1	0	46	110
0	0	1	1	1	1	15	79	1	0	1	1	1	1	47	111
0	1	0	0	0	0	16	80	1	1	0	0	0	0	48	112
0	1	0	0	0	1	17	81	1	1	0	0	0	1	49	113
0	1	0	0	1	0	18	82	1	1	0	0	1	0	50	114
0	1	0	0	1	1	19	83	1	1	0	0	1	1	51	115
0	1	0	1	0	0	20	84	1	1	0	1	0	0	52	116
0	1	0	1	0	1	21	85	1	1	0	1	0	1	53	117
0	1	0	1	1	0	22	86	1	1	0	1	1	0	54	118
0	1	0	1	1	1	23	87	1	1	0	1	1	1	55	119
0	1	1	0	0	0	24	88	1	1	1	0	0	0	56	120
0	1	1	0	0	1	25	89	1	1	1	0	0	1	57	121
0	1	1	0	1	0	26	90	1	1	1	0	1	0	58	122
0	1	1	0	1	1	27	91	1	1	1	0	1	1	59	123
0	1	1	1	0	0	28	92	1	1	1	1	0	0	60	124
0	1	1	1	0	1	29	93	1	1	1	1	0	1	61	125
0	1	1	1	1	0	30	94	1	1	1	1	1	0	62	126
0	1	1	1	1	1	31	95	1	1	1	1	1	1	63	127

NOTE: 1 = open; 0 = closed

*Table 3-6.  
Dual (not contiguous) Addressing Mode Jumper Settings*

Jumper	Position
E1	2 - 3
E2	1 - 2
E3	2 - 3
E5	2 - 3
E6	2 - 3
E8	2 - 3

**Digital Output (SW1, E4) Configuration**

Data are exchanged between the master module and the IMDER01 module over the Expander Bus. If there is a communication failure (master module failure, bus failure, etc.), the Slave Expander Bus interface enters an operating mode called "STALL". Jumper E4 is used to select the status of the outputs in "STALL" mode:

- Hold Slave output on Stall (loss of master)
- Go to Default output value on Stall (loss of master)

If Hold Slave output is selected the outputs are held at their status immediately before a communications failure with the master. If Go to Default output value is selected, the outputs are set to the default switch (SW1) values.

Jumper E4 and switch SW1 settings are shown in Tables 3-7 and 3-8.

*Table 3-7. Jumper E4 Configuration*

Jumper E4 Position	Function
1 - 2	Hold Slave output on Stall (Loss of master)
2 - 3	Go to default output value on Stall (Loss of master)

If the default output is enabled, in case of "STALL" the IMDER01 output the value configured on switch SW1.

There is a switch for each output, if a switch is set to 1 (1 = OFF), the corresponding output is closed (active) in case of "STALL".

Any combination of set is allowed, Table 3-8 gives, as examples, the possible configurations.

Table 3-8. Default Switch (SW1) Configuration Examples

1	2	3	4	5	6	7	8	Active Digital Output
0	0	0	0	0	0	0	0	None
0	0	0	0	0	0	0	1	1
0	0	0	0	0	0	1	0	2
0	0	0	0	0	1	0	0	3
0	0	0	0	1	0	0	0	4
0	0	0	1	0	0	0	0	5
0	0	1	0	0	0	0	0	6
1	0	0	0	0	0	0	0	7
1	0	0	0	0	0	0	0	8
1	1	1	1	1	1	1	1	All Active

NOTE: 1 = open; 0 = closed

**Digital Input Power Supply Detection Circuit Configuration (E7).**

The IMDER01 module uses an auxiliary input to detect power supply voltage presence at the digital inputs (e.g. if the termination unit is not powered on).

If this function is enabled, when no power is supplied to the inputs, the detection circuit modifies the status word, causing the master module to mark the input data point as bad quality (FC 84) and to issue bad status on digital output group block (FC 83).

If this function is disabled, an error is not flagged if there is no power supply to the digital inputs.

Table 3-9 shows jumper E7 settings.

Table 3-9. Jumper E7 Configuration

Jumper E7 Position	Function
1 - 2	Digital Input Power Supply Detection ENABLED
2 - 3	Digital Input Power Supply Detection DISABLED

**Other settings:**

XW13 and XW14 are factory set and should be present with all straps intact.

**TERMINATION UNIT NTU-7C8 CONFIGURATION**

An NTU-7C8 connects the field device wiring to the INFI 90 system. The terminal blocks (I/O connection points) are located on the termination unit. For details see APPENDIX A.

**Physical Installation (IMDER01)**

**NOTE:** The installation section provides instructions pertaining to the physical installation of the slave only. For complete cable and T.U. information, refer to the APPENDIX A.

The IMDER01 module plugs into a standard INFI 90 Module Mounting Unit (MMU) and occupies one slot. To install:

1. Verify the slot assignment of the module.

<b>WARNING</b>	<b>Disconnect power before installing dipshunts for slave modules on the MMU backplane (Slave Expander Bus). Failure to do so could result in severe or fatal shock.</b>
<b>AVERTISSEMENT</b>	<b>Couper l'alimentation avant d'installer les dipshunts sur la plaque arriere du chassis de montage de modules (MMU). Toute negligence à cet egard constitue un risque de choc pouvant entrainer des blessures graves, voire mortelles.</b>

2. Verify that a dipshunt is in the slave expander bus socket on the MMU backplane between the slave and master module.
3. Connect the hooded end of the termination cable from the T.U. to the MMU backplane. To do this, insert the connector into the backplane slot in the same slot as the one assigned to the slave module. The latches should snap securely into place.
4. Align the module with the plastic guide rails in the MMU; gently slide the module in until the front panel is flush with the top and the bottom of the MMU frame.
5. Push and turn the two captive retaining screws on the module faceplate one half turn to the latched position. It is latched when the slots on the screws are vertical and the open ends face the centre of the module. (To remove the module, turn the module retaining screws to the unlatched position and gently slide out).

### Physical Installation (NTU-7C8)

The NTU-7C8 termination unit stands on a standard INFI 90 field termination panel. To install the termination unit:

1. Configure all the jumpers on termination unit.
2. Install the termination unit on the field termination panel and secure into place with two screws.
3. Connect the wiring from the field, refer to this Appendix for terminal assignments.
4. Connect +24 VDC from an external source or from the system DC output bar to E1 on the NTU-7C8. Connect E2 to the external source common or to the system common on the DC input bus bar.
5. Connect the xKTU01 cable to P3 on termination unit.
6. Connect the cable for passive tile to J2 connector on termination unit.
7. Connect digital Input Power Supply from an external source (24/48/110/125 VDC or 120/127 VAC) or from the system DC output bar (+24 VDC) to E3 on the NTU-7C8. Connect E4 to the external source common or to the system common on the DC input bus bar.

The IMDER01 slave module and the relevant NTU-7C8 termination unit are standard Bailey INFI 90 components, especially designed to implement single drive I/O interfaces for on/off final actuators and relevant mosaic tiles handling.

The IMMFP01 calculates control strategies from the input data and sends process control data back to the slave module for output to the process.

The IMDER01 module and the NTU-7C8 are able to read 16 digital inputs and generate 8 digital outputs. The inputs are typically used to receive operator commands from the control desk panel (4 digital inputs: DI13÷DI16) and to read feedback signals from the actuator contacts (12 digital inputs: DI1÷DI12).

The outputs can drive signalling LEDs on the control desk tiles (5 digital outputs; DO4÷DO8) and issue ON/OFF commands to the final control drivers via power relays on the NTU-7C8 (3 digital outputs: DO1÷DO3).

Optoisolators in the NTU-7C8 termination unit galvanically isolate the field and the control panel devices. The IMDER01 module, inserted in one slot of the module mounting unit, is connected to the NTU-7C8 termination unit by means of a standard KTU01 cable.

The NTU-7C8 is composed of two interconnected boards and can be installed on the INFI 90 Field Termination Panel.

The IMDER01 module can acquire 12 digital inputs from the field and 4 digital signals from the control desk push buttons via NTU-7C8 termination unit.

It can also send 3 digital outputs to the field (2 of them via power relays) and 5 to the control desk signalling LEDs.

The DO1 and DO2 have different specifications from DO3.

### TERMINATION UNIT NTU-7C8 CONFIGURATION

**WIRING CONNECTION AND CABLING**

The IMDER01 has three card edge connectors to supply logic power, establish slave expander bus communication and provide digital input/output (P1, P2, P3 respectively).

**Wiring**

**NOTE:** You must install a dipshunt on the backplane of the MMU to connect the slave expander bus between the slave module and master module. Locate the modules so that they can be connected, over the bus or communication will not be possible.

Installing the module in the MMU connects the slave module to the logic power (+ 5 VDC, required to drive the circuitry), at P1. It also connects P2 to the slave expander bus for communication with the master module. P1 and P2 connection requires no additional wiring or cabling.

**Cable Connections**

The IMDER01 uses an NTU-7C8 for termination. See Figure 3-3 to determine the cables to use with the T.U. you are using.

**Connecting Termination Cable to MMU Backplane**

The KTU01 termination cable edge connector snaps securely into place in the backplane of the MMU. If the cable connector does not fit properly, do not force the connector into position. The connector slots in the MMU contain small notches that allow the connector to be inserted one way. Be aware of these notches when inserting the connector in the MMU backplane.

**FUSING**

The IMDER01 does not have any on board fusing requirements.

**PRE-OPERATING ADJUSTMENTS**

You do not have to make any adjustments to the IMDER01 prior to operating.

*Figure 3-3. IMDER01 Cable Connection and Termination Unit*

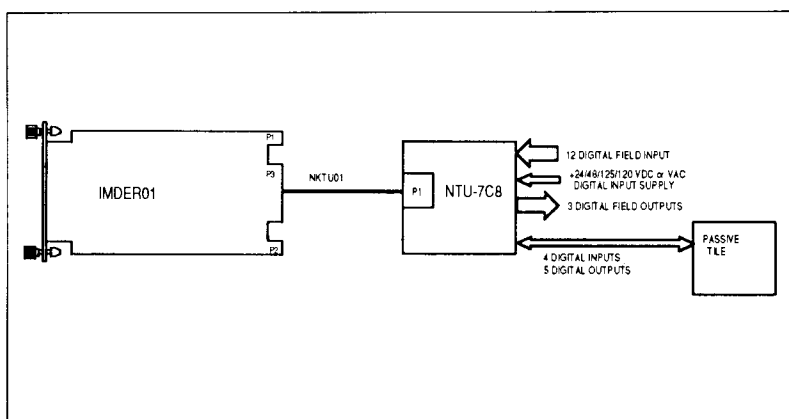



---

## SECTION 4 - OPERATING PROCEDURES

---

### INTRODUCTION

This section explains the front panel indicators and start-up procedures for the IMDER01 module.

---

### INDICATORS

The IMDER01 module has point (input/output) status LED indicators on the front panel to aid in system testing and diagnostics. There are sixteen LEDs divided in two groups of eight (group A and group B) for digital inputs. The location of the LEDs is shown in Figure 4-1. Each indicator represents a digital input. A red LED indicates an energized input (closed input). An off LED indicates a de-energized input (open input).

One group of eight LEDs (group A) is provided for digital outputs. The location of the LEDs is shown in Figure 4-1. Each indicator represents a digital output. A red LED indicates an energized output. An off LED indicates a de-energized output.

Further module status information is provided by the Red and Green LED visible through the module's front panel (a green LED indicates normal slave operation, a red LED indicates a malfunction).

---

### START-UP PROCEDURES

The master module controls the startup of the IMDER01 module, which is fully automatic. Function Code 84 and Function Code 83 in the master module configuration enables the IMDER01. Specification S1 of F.C. 84 and Specification S1 of F.C. 83 are the slave module address.

Figure 4-1. IMDER01 Front Panel

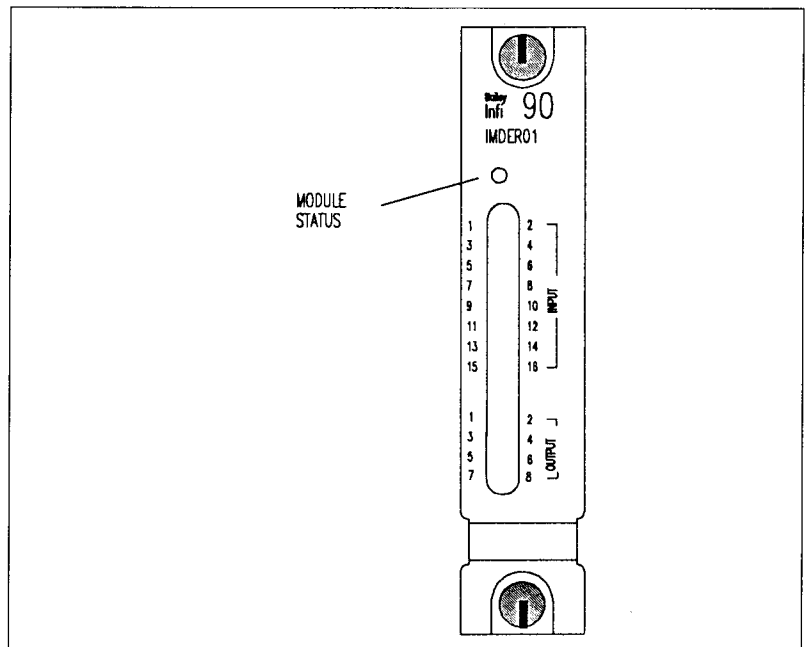

INTRODUCTION

---



---

## SECTION 5 - TROUBLESHOOTING

---

### INTRODUCTION

This section explains error indications and corrective action for the Digital Exchange Repeater (IMDER01) module.

---

### ERROR INDICATION AND CORRECTIVE ACTION

You can obtain the status of the IMDER01 by checking the master module for good quality at its input blocks using Fusing Code 84 or/and checking the output of Function Code 83 (0 = Good Status, 1 Bad Status (slave failed to respond)). Use an INFI 90 operator interface (Operator Interface Station, Engineering Work Station, Configuration and Tuning Terminal) to do this.

**NOTE:** if you at the IMDER01 front panel input/output status LED indicators and there are no LEDs lit, this may indicate a faulty IMDER01 ((an input or output must be energized to light a LED). Check the master module for bad quality at its input/output blocks. Also check module status LED. The LED must be Green in normal operating conditions. When the LED is Red or off there is a malfunction.

---

### MASTER MODULE ERRORS

The addresses set on the IMDER01 module (as shown in the Installation section) and in the master module configuration must be the same. The master module generates a MISSING SLAVE MODULE error if they do not match. Verify that the address set on IMDER01 is the same as the address in Function Code 84 specification S1 and Function Code 83 specification S1. If not:

1. Remove the module and change the setting of the IMDER01 address to correspond with the module configuration (refer to the installation section for the procedures to set an address and to install a slave module).

OR

2. Modify the address in the module configuration (F.C. 84 specification S1; F.C. 83 specification S1) to correspond with the address set on the IMDER01 module. Use an INFI 90 operator interface to modify a function code specification, refer to the Product Instruction for the operator interface you are using).

The master module generates a MISSING SLAVE MODULE error if the Slave Expander Bus is not connected between the slave module and the master module. Verify the bus connection on the MMU back plane.

**NOTE:** If F.C. 84 and F.C. 84 specification S3 is set to 0, the master module will trip when the IMDER01 module fails. Changing specifications S3 to a 1 will allow the master module to continue to operate if the slave fails.

If the slave module is found to be faulty, replace it with a new one. Refer to the Repair/Replacement Procedure Section for procedures to replace an IMDER01 module.

INTRODUCTION

---

**LED indications**

**IMDER01** (see Figure 4-1).

*MODULE STATUS*

GREEN Module initialized and master active on Slave Expander Bus.

RED Module on "STALL" (Master inactive)

Not lit Module not yet initialized.

*INPUT*

16 LEDs, lit when the corresponding input is closed

*OUTPUT*

8 LEDs, lit when the corresponding output is closed.

**NTU-7C8**

The T.U. has four LEDs to monitor the T.U. power supply and the field inputs power supply. Two LEDs indicate the power presence, whereas the other two indicate the power within range. The LEDs meaning is as below:

*Table 5-1. Termination Unit Power Supplies Signaling LEDs.*

<b>LED/Color</b>	<b>Meaning</b>
DS1/Green	Lit LED Signals T.U. Power Supply Presence Unlit LED Signals T.U. Power Supply Absence
DS2/Green	Lit LED Signals T.U. Digital Input Power Supply Presence Unlit LED Signals T.U. Digital Input Power Supply Absence
DS3/Jellow	Unlit LED Signals T.U. Power Supply into range Lit LED Signals T.U. Power Supply out of range
DS4/Jellow	Unlit LED Signals T.U. Digital Input Power Supply into range Lit LED Signals T.U. Digital Input Power Supply out of range

**MODULE PIN CONNECTIONS**

The slave module has three connector for external signals and power (P1, P2 and P3). Tables 5-2, 5-3 and 5-4 show the pin assignment.

*Table 5-2. P1 Power connector Pin Assignments*

Pin (P1)	Connection
1	+ 5 VDC
2	+5 VDC
3	NC
4	NC
5	Common
6	Common
7	NC
8	NC
9	NC
10	NC
11	NC
12	NC

**NOTE:** NC = Not Connected

*Table 5-3. P2 Expander Bus Connector Pin Assignments*

Pin (P1)	Connection
1	Data 1
2	Data 0
3	Data 3
4	Data 2
5	Data 5
6	Data 4
7	Data 7
8	Data 6
9	Clock
10	Sync
11	NC
12	NC

**NOTE:** NC = Not Connected

Table 5-4. P3 Digital I/O Signal Connector Pin Assignments

Pin (P3)	Connection	Pin (P3)	Connections
1	Digital Input 2	A	Digital Input 1
2	Digital Input 4	B	Digital Input 3
3	Digital Input 6	C	Digital Input 5
4	Digital Input 8	D	Digital Input 7
5	Digital Input 10	E	Digital Input 9
6	Voltage Control	F	+24/+48 VDC Digital Input
7	Digital Input 12	H	Digital Input 11
8	COM I/O	J	+24/+48 VDC Digital Output
9	Digital Output 2	K	Digital Output 1
10	Digital Output 4	L	Digital Output 3
11	Digital Output 6	M	Digital Output 5
12	Digital Output 8	N	Digital Output 7
13	Digital Input 14	P	Digital Output 13
14	COM I/O	R	COM I/O
15	Digital Input 16	S	Digital Output 15

---

## SECTION 6 - MAINTENANCE

---

### **INTRODUCTION**

The IMDER01 module requires limited maintenance. This section contains a maintenance schedule.

---

### **MAINTENANCE SCHEDULE**

Perform the tasks in Table 6-1 at the specified intervals.

*Table 6-1. Maintenance Schedule*

<b>Task</b>	<b>Interval</b>
Clean and tighten all power and grounding connections.	Every 6 months or during plant shutdown, whichever occurs first.
Use a static safe vacuum cleaner to remove dust from:  Modules Module Mounting Unit Fan Assembly Power Entry Panel	



---

## SECTION 7 - REPAIR/REPLACEMENT PROCEDURES

---

### **INTRODUCTION**

This section explains the replacement procedures for a Digital Exchange Repeater (IMDER01) module. There are no special tools required to replace an IMDER01 module.

---

### **MODULE REPAIR/REPLACEMENT**

If the IMDER01 is found to be faulty, replace it with a new one. **DO NOT** try to repair the module; replacing components may affect module performance. You can remove the module while system power is supplied. To replace a module:

1. Push and turn the two front panel captive retaining screws one half turn to unlatch the module. It is unlatched when the slots on the screws are vertical and the open end of the slots face away from the module.
2. Gently slide the module out of the MMU.
3. Configure the replacement module switches, jumpers and dipshunt settings. Ensure they are set the same as the original module.
4. In the same slot assignment as the original module, align the replacement module with the plastic guide rails in the MMU; gently slide it in until the front panel is flush with the top and bottom of the MMU frame.
5. Push and turn the two captive retaining screws on the module faceplate one half turn to the latched position. It is latched when the slots on the screws are vertical and the open ends face the centre of the module.
6. Return to normal operation.



---

## SECTION 8 - SUPPORT SERVICES

---

### **INTRODUCTION**

Elsag Bailey is ready to help in the use, application and repair of its products. Contact your nearest sales office to make requests for sale, application, installation, repair, overhaul and maintenance contract services.

---

### **REPLACEMENT PART AND ORDERING INFORMATION**

When making repairs at your facility, order replacement parts an Elsag Bailey sales office. Provide this information:

1. Part description, part number and quality.
2. Model and serial numbers (if applicable)
3. Elsag Bailey instruction manual number, page number and reference figure that identifies the part.

You can order parts without commercial description from the nearest Elsag Bailey sales offices.

---

### **TRAINING**

Elsag Bailey has a modern training facility that provides service and repair instruction. This facility is available for in-plant training of your personnel.

Contact an Elsag Bailey sales office for detailed information and scheduling.

---

### **TECHNICAL DOCUMENTATION**

You can obtain additional copies of this manual from the nearest Elsag Bailey sales office at a reasonable charge.



# APPENDIX A

## TERMINATION UNIT CONFIGURATION

### INTRODUCTION

The IMDER01 module uses the NTU-7C8 as Termination Unit. The Termination Unit must be configured according to the application.

### TERMINATION UNIT (NTU-7C8) CONFIGURATION

The NTU-7C8 termination unit comprises two piggy-back modules (FIR-789 and FJB-789). It is used with the DER module to implement a single drive control unit. Figure A-1 shows the cable connections for the NTU-7C8. Refer to Tables A-1, A-2 and A-3 for termination unit configuration.

Digital I/O to field connections are made at terminal blocks TB1, TB2 and TB3. Connector J2 makes connections between the digital I/Os and the control tile. Terminal blocks signal assignment and J2 connector pin-out is shown in Tables A-1 and A-2. Figures A-2 and A-3 show the components layout for the upper (FJB-789) and lower (FIR-789) modules.

Figure A-1. Cable Connections For NTU-7C8.

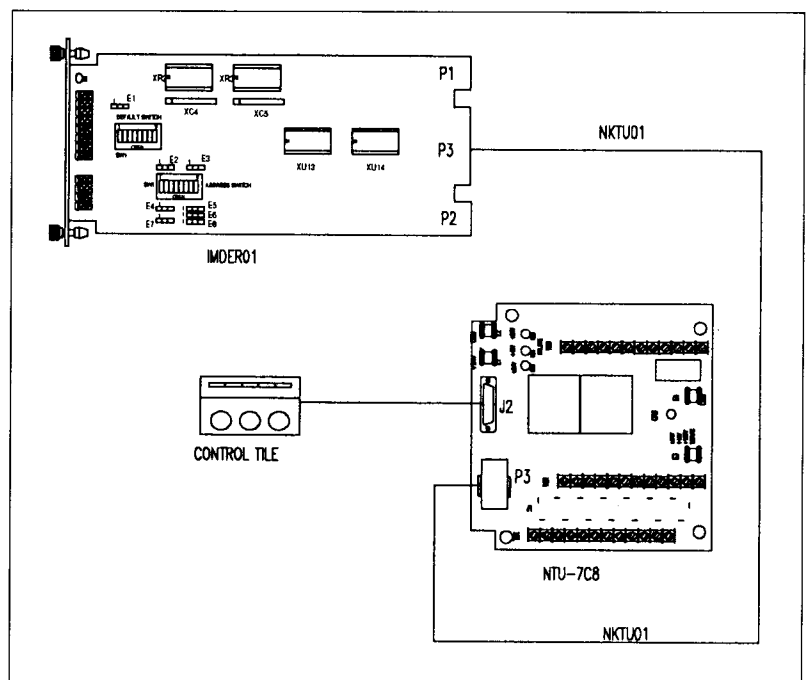
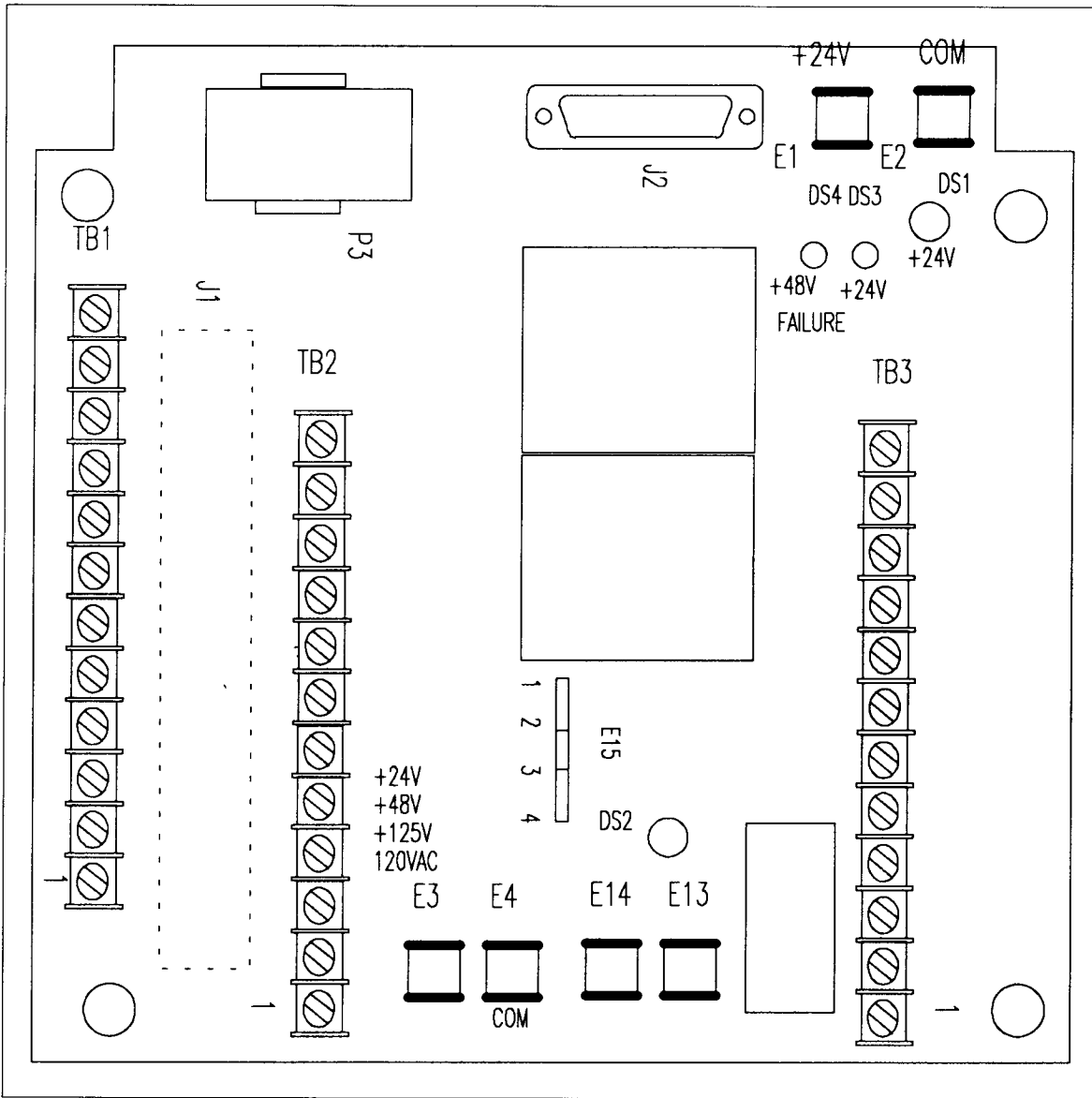
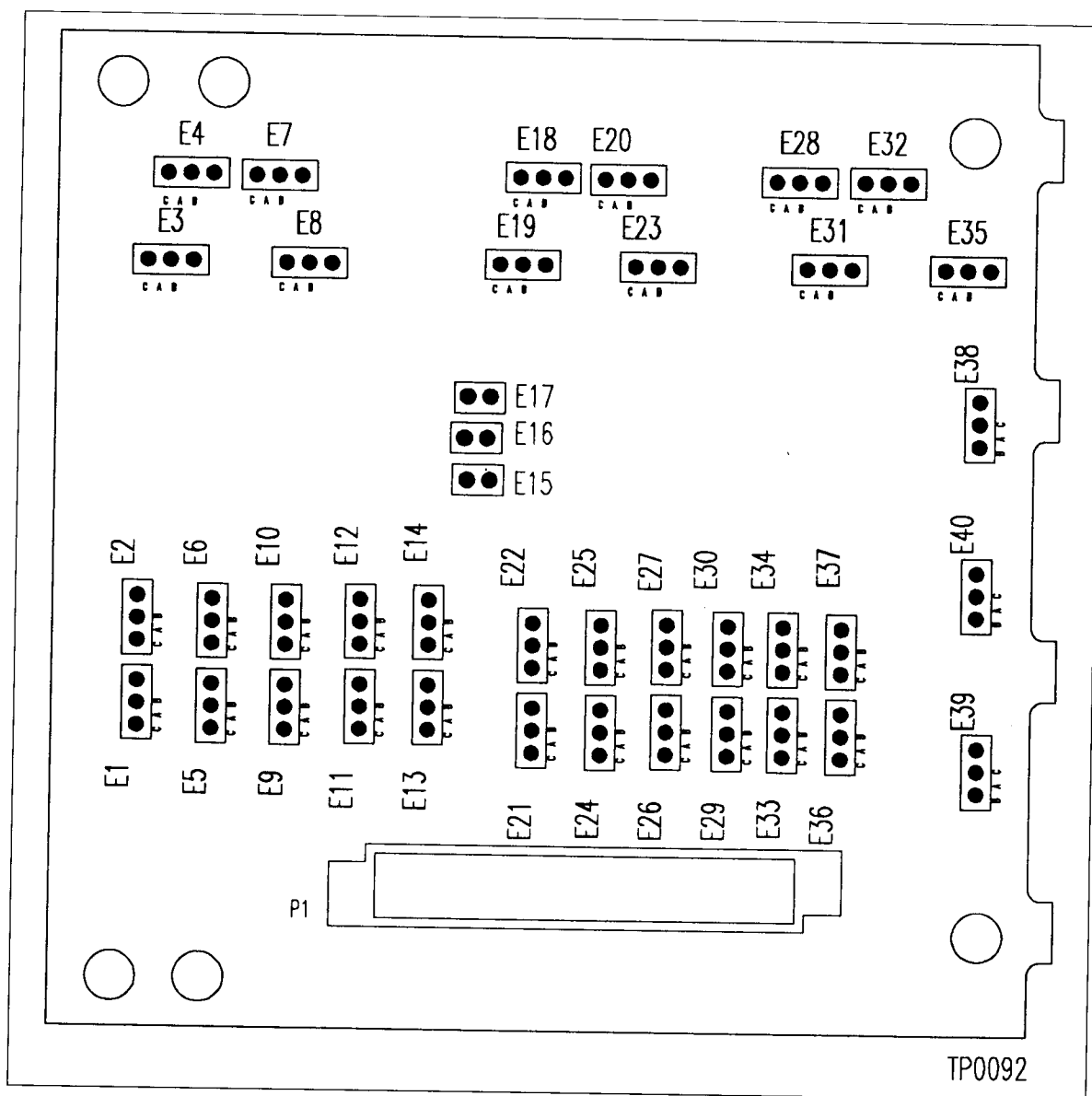

Figure A-2. FJB-789 Components Location.



TERMINATION UNIT (NTU-7C8) CONFIGURATION

Figure A-3. FIR-789 Connector and Jumpers Arrangements.



TERMINATION UNIT (NTU-7C8) CONFIGURATION

Table A-1. NTU-7C8 Terminal Block Assignments

Terminal Block	Pin	Signal
TB 1	1	D I 1
	2	D I 1 (+)
TB 1	3	D I 2 (+)
	4	D I 2
TB 1	5	D I 3
	6	D I 3 (+)
TB 1	7	D I 4 (+)
	8	D I 4
TB 1	9	D I 5
	10	D I 5 (+)
TB 1	11	D I 6 (+)
	12	D I 6
TB 2	1	D I 7
	2	D I 7 <sup>(1)</sup>
TB 2	3	D I 8 (+)
	4	D I 8
TB 2	5	D I 9
	6	D I 9 (+)
TB 2	7	D I 10 (+)
	8	D I 10
TB 2	9	D I 11
	10	D I 11 (+)
TB 2	11	D I 12 (+)
	12	D I 12
TB 3		DO 3
	1	CONTACTS COMMON
	2	N.C.
	3	CONTACTS COMMON
TB 3	4	N.O.
		DO 2
	5	N.C.
	6	N.C.
TB 3	7	N.O.
	8	N.O.
		DO 1
	9	N.C.
TB 3	10	N.C.
	11	N.O.
	12	N.O.

**NOTE:** 1) Positive when this input is configured as System Powered and don't care when this input is configured as Externally Powered.  
N.C. Normally Closed  
N.O. Normally Open

Table A-2. J2 Connector Terminal Assignments

Pin	Signal
1	NOT USED
2	NOT USED
3	NOT USED
4	NOT USED
5	I/O COMMON
6	I/O COMMON
7	DO 4
8	DO 8
9	DO 5
10	DO 6
11	DI 13
12	DI 15
13	DI 14
14	DI 16
15	DO 7

TERMINATION UNIT (NTU-7C8) CONFIGURATION

Table A-3. Jumper Settings for NTU-7C8 Digital Inputs

Digital Input/Channel	24 VDC	48 VDC	100/125 VDC
Input Channel Power Supply Alarm Circuit	E15 1 (1) E16 0 E17 0 (on FJB-789)	E15 0 E16 0 E17 1 (on FJB-789)	E15 0 E16 1 E17 0 (on FJB-789)
DI 1	E36 A - C (2) E37 A - C E32 A - B (on FIR-789)	E36 A - C E37 A - B E32 A - B (on FIR-789)	E36 A - B E37 A - B E32 A - B (on FIR-789)
DI 2	E33 A - C E34 A - C E28 A - B (on FIR-789)	E33 A - C E34 A - B E28 A - B (on FIR-789)	E33 A - B E34 A - B E28 A - B (on FIR-789)
DI 3	E29 A - C E30 A - C E31 A - B (on FIR-789)	E29 A - C E30 A - B E31 A - B (on FIR-789)	E29 A - B E30 A - B E31 A - B (on FIR-789)
DI 4	E26 A - C E27 A - C E35 A - B (on FIR-789)	E26 A - C E27 A - B E35 A - B (on FIR-789)	E26 A - B E27 A - B E35 A - B (on FIR-789)
DI 5	E24 A - C E25 A - C E20 A - B (on FIR-789)	E24 A - C E25 A - B E20 A - B (on FIR-789)	E24 A - B E25 A - B E20 A - B (on FIR-789)
DI 6	E21 A - C E22 A - C E18 A - B (on FIR-789)	E21 A - C E22 A - B E18 A - B (on FIR-789)	E21 A - B E22 A - B E18 A - B (on FIR-789)
DI 7	see NOTE (3)	see NOTE (3)	see NOTE (3)
DI 8	E13 A - C E14 A - C E23 A - B (on FIR-789)	E13 A - C E14 A - B E23 A - B (on FIR-789)	E13 A - B E14 A - B E23 A - B (on FIR-789)
DI 9	E11 A - C E12 A - C E7 A - B (on FIR-789)	E11 A - C E12 A - B E7 A - B (on FIR-789)	E11 A - B E12 A - B E7 A - B (on FIR-789)
DI 10	E9 A - C E10 A - C E4 A - B (on FIR-789)	E9 A - C E10 A - B E4 A - B (on FIR-789)	E9 A - B E10 A - B E4 A - B (on FIR-789)
DI 11	E5 A - C E6 A - C E3 A - B (on FIR-789)	E5 A - C E6 A - B E3 A - B (on FIR-789)	E5 A - B E6 A - B E3 A - B (on FIR-789)
DI 12	E1 A - C E2 A - C E8 A - B (on FIR-789)	E1 A - C E2 A - B E8 A - B (on FIR-789)	E1 A - B E2 A - B E8 A - B (on FIR-789)

**NOTE:** 1) 1 = Jumper Fitted; 0 = Jumper Missing 2) A-B or A-C Indicates Jumper Position.  
3) Refer to Table A-4 for Jumper Setting of this Input.

TERMINATION UNIT (NTU-7C8) CONFIGURATION

Table A-3. Jumper Settings for NTU-7C8 Digital Inputs (Continued)

Digital Input/Channel	24 VAC	48 VAC	100/127 VAC
Input Channel Power Supply Alarm Circuit	E15 1 (1) E16 0 E17 0 (on FIR-789)	E15 0 E16 0 E17 1 (on FJB-789)	E15 0 E16 1 E17 0 (on FJB-789)
DI 1	E36 A - C (2) E37 A - C E32 A - C (on FIR-789)	E36 A - C E37 A - B E32 A - C (on FIR-789)	E36 A - B E37 A - B E32 A - C (on FIR-789)
DI 2	E33 A - C E34 A - C E28 A - C (on FIR-789)	E33 A - C E34 A - B E28 A - C (on FIR-789)	E33 A - B E34 A - B E28 A - C (on FIR-789)
DI 3	E29 A - C E30 A - C E31 A - C (on FIR-789)	E29 A - C E30 A - B E31 A - C (on FIR-789)	E29 A - B E30 A - B E31 A - C (on FIR-789)
DI 4	E26 A - C E27 A - C E35 A - C (on FIR-789)	E26 A - C E27 A - B E35 A - C (on FIR-789)	E26 A - B E27 A - B E35 A - C (on FIR-789)
DI 5	E24 A - C E25 A - C E20 A - C (on FIR-789)	E24 A - C E25 A - B E20 A - C (on FIR-789)	E24 A - B E25 A - B E20 A - C (on FIR-789)
DI 6	E21 A - C E22 A - C E18 A - C (on FIR-789)	E21 A - C E22 A - B E18 A - C (on FIR-789)	E21 A - B E22 A - B E18 A - C (on FIR-789)
DI 7	see NOTE (3)	see NOTE (3)	see NOTE (3)
DI 8	E13 A - C E14 A - C E23 A - C (on FIR-789)	E13 A - C E14 A - B E23 A - C (on FIR-789)	E13 A - B E14 A - B E23 A - C (on FIR-789)
DI 9	E11 A - C E12 A - C E7 A - C (on FIR-789)	E11 A - C E12 A - B E7 A - C (on FIR-789)	E11 A - B E12 A - B E7 A - C (on FIR-789)
DI 10	E9 A - C E10 A - C E4 A - C (on FIR-789)	E9 A - C E10 A - B E4 A - C (on FIR-789)	E9 A - B E10 A - B E4 A - C (on FIR-789)
DI 11	E5 A - C E6 A - C E3 A - C (on FIR-789)	E5 A - C E6 A - B E3 A - C (on FIR-789)	E5 A - B E6 A - B E3 A - C (on FIR-789)
DI 12	E1 A - C E2 A - C E8 A - C (on FIR-789)	E1 A - C E2 A - B E8 A - C (on FIR-789)	E1 A - B E2 A - B E8 A - C (on FIR-789)

**NOTE:** 1) 1 = Jumper Fitted; 0 = Jumper Missing 2) A-B or A-C Indicates Jumper Position.  
3) Refer to Table A-4 for Jumper Setting of this Input.

TERMINATION UNIT (NTU-7C8) CONFIGURATION

Table A-4. Digital Input Jumper Settings

Digital Input Signal Type	24 VDC	48 VDC	110/125 VDC	120/127 VAC	220 VAC
System Powered from E3/E4 E15 1-2 3-4 (on FJB-789)	E39 A-B E40 A-C E38 A-C E19 A-B (on FIR-789)	E39 A-B E40 A-C E38 A-B E19 A-B (on FIR-789)	E39 A-B E40 A-B E38 A-B E19 A-B (on FIR-789)	E39 A-B E40 A-B E38 A-B E19 A-C (on FIR-789)	Not Available
	<b>24 VDC</b>	<b>48 VDC</b>			
	E39 A-B E40 A-C E38 A-C E19 A-C (on FIR-789)	E39 A-B E40 A-C E38 A-B E19 A-C (on FIR-789)			
	<b>+ 24 VDC</b>	<b>+ 48 VDC</b>	<b>110/125 VDC</b>	<b>120/127 VAC</b>	<b>220 VAC</b>
Field Powered E15 2-3 (on FJB-789)	E39 A-B E40 A-C E38 A-C E19 A-B (on FIR-789)	E39 A-B E40 A-C E38 A-B E19 A-B (on FIR-789)	E39 A-B E40 A-B E38 A-B E19 A-B (on FIR-789)	E39 A-B E40 A-B E38 A-B E19 A-C (on FIR-789)	E39 A-C E40 A-B E38 A-B E19 A-C (on FIR-789)
	<b>24 VAC</b>	<b>48 VAC</b>			
	E39 A-B E40 A-C E38 A-C E19 A-C (on FIR-789)	E39 A-B E40 A-C E38 A-B E19 A-C (on FIR-789)			







**For prompt, personal attention to your instrumentation and control needs or a full listing of  
Bailey representatives in principal cities around the world, contact the Bailey location nearest you.**

---

**Australia**

Bailey Australia Pty. Limited  
26 Auburn Road  
Regents Park, New South Wales 2143  
Telephone: 61-2-645-3322  
Telefax: 61-2-645-2212

**Brazil**

Bailey do Brasil  
Alameda Campinas 463,  
conj. 5A and 5B  
01404-902 Sao Paulo SP  
Telephone: 55-11-288-4000  
Telefax: 55-11-289-0057

**Canada**

Bailey Canada  
860 Harrington Court  
Burlington, Ontario L7N 3N4  
Telephone: 1-905-639-8840  
Telefax: 1-905-639-8639

**China, People's Republic of**

Bailey Beijing Controls Co., Ltd.  
41 Gulou West Street  
Beijing  
Telephone: 86-1-401-0651  
Telefax: 86-1-401-1643

**France**

Elsag Bailey SA  
100, rue de Paris  
Massy Cedex 91342  
Telephone: 33-1-64-47-2000  
Telefax: 33-1-64-47-2016

**Germany**

Bailey MD Automation GmbH  
Zum Alten Wasserwerk 9  
5063 Overath 6, Cologne  
Telephone: 49-220-4-739-0  
Telefax: 49-220-4-739-79

**Italy**

Elsag Bailey  
Via Puccini 2  
16154 Genova  
Telephone: 39-10-658-2-944  
Telefax: 39-10-658-2-941

**Japan**

Bailey Japan Company, Ltd.  
511 Baraki, Nirayama-Cho  
Tagata-Gun, Shizuoka-Ken, 410-21  
Telephone: 81-559-49-3311  
Telefax: 81-559-49-1114

**Jordan**

Bailey Controls Jordan  
P.O. Box 2310  
Amman  
Telephone: 962-6-756-908  
Telefax: 962-6-756-908

**Mexico**

Bailey Mexico, SA de CV  
Felix Guzman No. 15  
Col. El Parque  
Naucalpan, Edo de Mexico 55390  
Telephone: 52-5-557-6100  
Telefax: 52-5-395-3984

**Netherlands**

Bailey Nederland BV  
P.O. Box 572, 3190 AM Botlek Rt.  
Welplaathoek 20  
3197 KP Botlek/Rotterdam  
Telephone: 31-10-416-9696  
Telefax: 31-10-416-9423

**Norway**

Bailey Petrovest AS  
Box 93, Kokstaddalen 4  
N-5061 Kokstad, Bergen  
Telephone: 47-55-229-601  
Telefax: 47-55-229-610

**Singapore**

Elsag Bailey Pte. Ltd.  
750 E. Chai Chee Road, 05-03  
Singapore, 1646  
Telephone: 65-442-3200  
Telefax: 65-442-2700

**United Kingdom**

Bailey ICS plc  
Hortonwood 37  
Telford, Shropshire TF1 4GT  
Telephone: 44-952-670-477  
Telefax: 44-952-670-455

**United States**

Bailey Controls Company  
29801 Euclid Avenue  
Wickliffe, Ohio 44092  
Telephone: 1-216-585-8500  
Telefax: 1-216-585-8756

Electronic Technology Systems, Inc.  
P.O. Box 366  
New Kensington, Pennsylvania 15068  
Telephone: 1-412-335-1300  
Telefax: 1-412-335-2450

Network Management Technology, Inc.  
P.O. Box 5031  
Sugar Land, Texas 77487  
Telephone: 1-713-274-5000  
Telefax: 1-713-240-6986

**Venezuela**

Bailey de Venezuela S.A.  
Este Oeste No. 6, Parcela 216, 218  
Galpon No. 4  
Valencia  
Telephone: 58-41-405-138  
Telefax: 58-41-322-994

Form EI-E97-303A/E Litho in Italy 0694

Copyright © 1993 by Elsag Bailey Process Automation

® Registered Trademark of Elsag Bailey Process Automation

™ Trademark of Elsag Bailey Process Automation

**Elsag Bailey**

A Finmeccanica Company

Via G. Puccini, 2 - 16154 Genova - Italy  
Phone 39.10.6581 - Fax 39.10.6582898