

E96-610

Bailey®
infi 90

Instruction

INFI-NET to Computer Interfaces (INICI01/03)

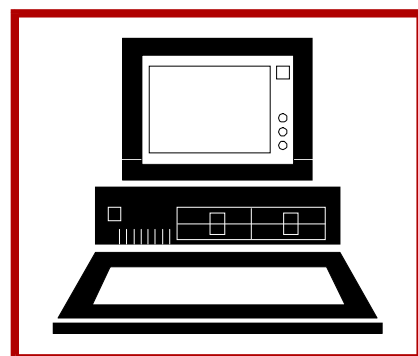
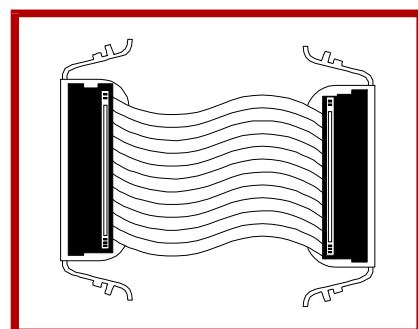
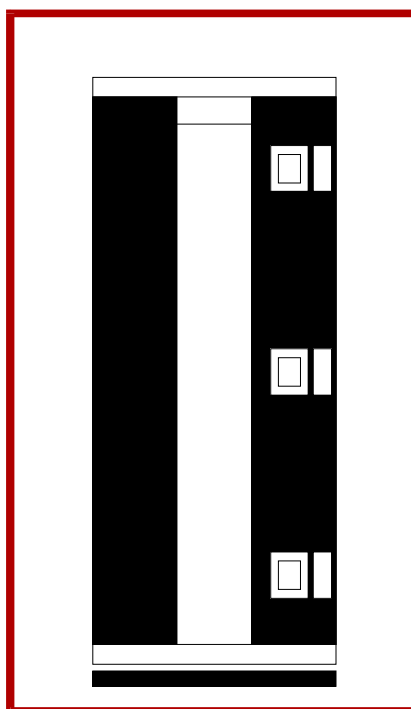
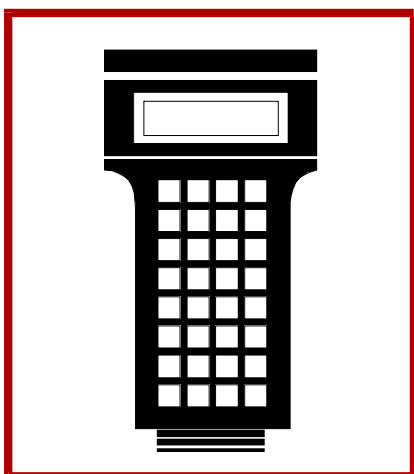
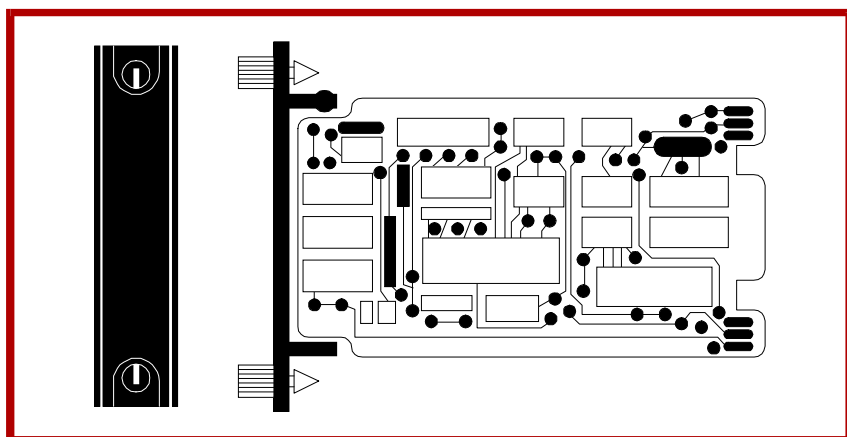
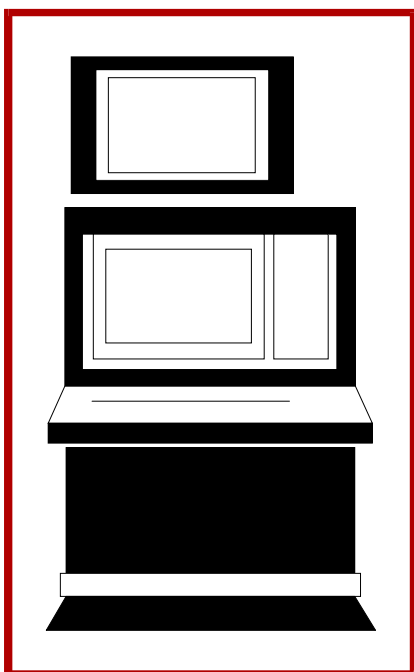

WARNING notices as used in this instruction apply to hazards or unsafe practices that could result in personal injury or death.

CAUTION notices apply to hazards or unsafe practices that could result in property damage.

NOTES highlight procedures and contain information that assists the operator in understanding the information contained in this instruction.

WARNING

INSTRUCTION MANUALS

DO NOT INSTALL, MAINTAIN, OR OPERATE THIS EQUIPMENT WITHOUT READING, UNDERSTANDING, AND FOLLOWING THE PROPER **Elsag Bailey** INSTRUCTIONS AND MANUALS; OTHERWISE, INJURY OR DAMAGE MAY RESULT.

RADIO FREQUENCY INTERFERENCE

MOST ELECTRONIC EQUIPMENT IS INFLUENCED BY RADIO FREQUENCY INTERFERENCE (RFI). CAUTION SHOULD BE EXERCISED WITH REGARD TO THE USE OF PORTABLE COMMUNICATIONS EQUIPMENT IN THE AREA AROUND SUCH EQUIPMENT. PRUDENT PRACTICE DICTATES THAT SIGNS SHOULD BE POSTED IN THE VICINITY OF THE EQUIPMENT CAUTIONING AGAINST THE USE OF PORTABLE COMMUNICATIONS EQUIPMENT.

POSSIBLE PROCESS UPSETS

MAINTENANCE MUST BE PERFORMED ONLY BY QUALIFIED PERSONNEL AND ONLY AFTER SECURING EQUIPMENT CONTROLLED BY THIS PRODUCT. ADJUSTING OR REMOVING THIS PRODUCT WHILE IT IS IN THE SYSTEM MAY UPSET THE PROCESS BEING CONTROLLED. SOME PROCESS UPSETS MAY CAUSE INJURY OR DAMAGE.

AVERTISSEMENT

MANUELS D'OPÉRATION

NE PAS METTRE EN PLACE, RÉPARER OU FAIRE FONCTIONNER L'ÉQUIPEMENT SANS AVOIR LU, COMPRIS ET SUIVI LES INSTRUCTIONS RÉGLEMENTAIRES DE **Elsag Bailey**. TOUTE NÉGLIGENCE À CET ÉGARD POURRAIT ÊTRE UNE CAUSE D'ACCIDENT OU DE DÉFAILLANCE DU MATÉRIEL.

PERTURBATIONS PAR FRÉQUENCE RADIO

LA PLUPART DES ÉQUIPEMENTS ÉLECTRONIQUES SONT SENSIBLES AUX PERTURBATIONS PAR FRÉQUENCE RADIO. DES PRÉCAUTIONS DEVRONT ÊTRE PRISES LORS DE L'UTILISATION DU MATÉRIEL DE COMMUNICATION PORTATIF. LA PRUDENCE EXIGE QUE LES PRÉCAUTIONS À PRENDRE DANS CE CAS SOIENT SIGNALÉES AUX ENDROITS VOULUS DANS VOTRE USINE.

PERTURBATIONS DU PROCÉDÉ

L'ENTRETIEN DOIT ÊTRE ASSURÉ PAR UNE PERSONNE QUALIFIÉE EN CONSIDÉRANT L'ASPECT SÉCURITAIRE DES ÉQUIPEMENTS CONTRÔLÉS PAR CE PRODUIT. L'AJUSTEMENT ET/OU L'EXTRACTION DE CE PRODUIT PEUT OCCASIONNER DES À-COUPS AU PROCÉDÉ CONTRÔLE LORSQU'IL EST INSÉRÉ DANS UNE SYSTÈME ACTIF. CES À-COUPS PEUVENT ÉGALEMENT OCCASIONNER DES BLESSURES OU DES DOMMAGES MATÉRIELS.

NOTICE

The information contained in this document is subject to change without notice.

Elsag Bailey, its affiliates, employees, and agents, and the authors and contributors to this publication specifically disclaim all liabilities and warranties, express and implied (including warranties of merchantability and fitness for a particular purpose), for the accuracy, currency, completeness, and/or reliability of the information contained herein and/or for the fitness for any particular use and/or for the performance of any material and/or equipment selected in whole or part with the user of/or in reliance upon information contained herein. Selection of materials and/or equipment is at the sole risk of the user of this publication.

This document contains proprietary information of Elsag Bailey, Elsag Bailey Process Automation, and is issued in strict confidence. Its use, or reproduction for use, for the reverse engineering, development or manufacture of hardware or software described herein is prohibited. No part of this document may be photocopied or reproduced without the prior written consent of Elsag Bailey.

Preface

The INICIO1 and INICIO3 INFI-NET[®] to Computer Interfaces provide a host computer or console with access to an INFI-NET communication loop. State-of-the-art INFI 90[®] modules are used in these interfaces.

The INNISO1 Network Interface Slave Module (NIS) is a part of all INFI-NET to computer interfaces. It provides the intelligent link between a node and an INFI-NET loop. One NIS module and one INICT01 INFI-NET to Computer Transfer Module make up an INICIO1 INFI-NET to Computer Interface. One NIS module, one INICT03 INFI-NET to Computer Transfer Module, and one IMMPIO1 Multi-Function Processor Interface Module make up an INICIO3 INFI-NET to Computer Interface.

This instruction explains INFI-NET to computer interface features, specifications, and operation. It also includes installation and troubleshooting procedures for each module.

List of Effective Pages

Total number of pages in this instruction is 94, consisting of the following:

Page No.	Change Date
Preface	Original
List of Effective Pages	Original
iii through ix	Original
1-1 through 1-8	Original
2-1 through 2-6	Original
3-1 through 3-20	Original
4-1 through 4-12	Original
5-1 through 5-6	Original
6-1 through 6-4	Original
7-1 through 7-2	Original
8-1	Original
A-1 through A-3	Original
B-1 through B-3	Original
C-1 through C-5	Original
D-1 through D-5	Original
E-1 through E-4	Original
F-1 through F-4	Original
Index-1 through Index-2	Original

When an update is received, insert the latest changed pages and dispose of the superseded pages.

NOTE: On an update page, the changed text or table is indicated by a vertical bar in the outer margin of the page adjacent to the changed area. A changed figure is indicated by a vertical bar in the outer margin next to the figure caption. The date the update was prepared will appear beside the page number.

Safety Summary

**GENERAL
WARNINGS****Equipment Environment**

All components, whether in transportation, operation or storage, must be in a noncorrosive environment.

Electrical Shock Hazard During Maintenance

Disconnect power or take precautions to insure that contact with energized parts is avoided when servicing.

Special Handling

This module uses electrostatic sensitive devices (ESD).

**SPECIFIC
WARNINGS**

Disconnect power before installing dipshunts on the module mounting unit backplane. Failure to do so will result in contact with cabinet areas that could cause severe or fatal shock. (p. 3-8, 3-12, 3-20)

Wear eye protection whenever working with cleaning solvents. When removing solvents from printed circuit boards using compressed air, injury to the eyes could result from splashing solvent as it is blown off the printed circuit board. (p. 6-1)

**SPECIFIC
CAUTIONS**

Never operate the ICT module with the machine fault timer circuit disabled (jumper pins connected). Unpredictable module outputs may result. These unpredictable module outputs may adversely affect the entire communication system. (p. 3-16)

To avoid potential module damage, evaluate your system for compatibility prior to module installation. This module uses connections to the module mounting unit backplane that served other functions in early Network 90 systems. (p. 3-19)

Sommaire de Sécurité

**AVERTISSEMENT
D'ORDRE
GENERAL**

Environnement de l'Équipement

Nes pas soumettre les composants à une atmosphère corrosive lors du transport, de l'entreposage ou l'utilisation.

Possibilité de Chocs Électriques Durant l'Entretien

Débrancher l'alimentation ou de prendre les précautions pour éviter tout contact avec des composants sous tension durant l'entretien.

Précautions de Manutention

Ce module contient des composantes sensibles aux décharges électrostatiques.

**AVERTISSEMENT
D'ORDRE
SPECIFIQUE**

Interrompez l'alimentation avant d'installer des dipshunts sur le fond de panier du châssis de montage des modules. Sinon, tout contact avec cette zone entraîne des risques d'électrocution sérieuse ou fatale. (p. 3-8, 3-12, 3-20)

Portez toujours des lunettes de protection lorsque vous utilisez des solvants de nettoyage. L'air comprimé servant à enlever le solvant des cartes de circuits imprimés provoque des éclaboussures qui risquent d'atteindre les yeux. (p. 6-1)

**ATTENTION
D'ORDRE
SPECIFIQUE**

Ne jamais faire fonctionner le module ICT alors que le circuit MFT (Machine Fault Timer) est hors-circuit. Il pourrait en résulter des sorties imprévisibles. Ces sorties imprévisibles pourraient affecter très défavorablement le système entier de communication. (p. 3-16)

Pour éviter d'endommager des modules, évaluez la compatibilité de votre système avant de les y brancher. L'usage que fait ce module de certaines connexions au fond de panier du châssis de montage diffère de l'assignation prévue par le système Network 90 original. (p. 3-19)

Table of Contents

	<i>Page</i>
SECTION 1 - INTRODUCTION	1-1
OVERVIEW	1-1
INTENDED USER	1-1
COMPUTER INTERFACE DESCRIPTION	1-1
INICIO1 INFI-NET to Computer Interface	1-1
INICIO3 INFI-NET to Computer Interface	1-1
MODULE DESCRIPTION	1-2
INNIS01 Network Interface Slave Module	1-2
INICT01 INFI-NET to Computer Transfer Module	1-3
INICT03 INFI-NET to Computer Transfer Module	1-3
IMMPI01 Multi-Function Processor Interface Module	1-4
FEATURES	1-4
INSTRUCTION CONTENT	1-5
HOW TO USE THIS MANUAL	1-5
GLOSSARY OF TERMS AND ABBREVIATIONS	1-6
REFERENCE DOCUMENTS	1-6
NOMENCLATURE	1-6
SPECIFICATIONS	1-7
SECTION 2 - DESCRIPTION AND OPERATION	2-1
INTRODUCTION	2-1
MODULE INTEGRITY	2-1
INNIS01 NETWORK INTERFACE SLAVE MODULE	2-1
Exception Reports	2-1
Messages	2-2
Broadcast	2-2
Time Synchronization	2-2
Multicast	2-2
NIS Poll	2-2
Message Format	2-2
Message Transmission	2-3
NIS Data Integrity	2-3
Retry Logic	2-3
Node Status Table	2-3
Polling	2-3
INICT01 INFI-NET TO COMPUTER TRANSFER MODULE	2-4
INICT03 INFI-NET TO COMPUTER TRANSFER MODULE	2-4
INFI-NET TO COMPUTER INTERFACE COMMANDS	2-5
Data Acquisition	2-5
Configuration	2-6
Process Control	2-6
System Status	2-6
SECTION 3 - INSTALLATION	3-1
INTRODUCTION	3-1
SPECIAL HANDLING	3-1
UNPACKING AND INSPECTION	3-2
INNIS01 NETWORK INTERFACE SLAVE MODULE CONFIGURATION	3-2
Dipswitch Settings	3-2
Dipswitch SW1 - Node Address	3-3
Dipswitch SW2 - Loop Address	3-3
Dipswitch SW3 - Loop Mode	3-3
Dipswitch SW4 - I/O Module Address and Counters	3-4
Jumper Settings	3-6
Power System Status	3-7

Table of Contents (continued)

	<i>Page</i>
SECTION 3 - INSTALLATION (continued)	
INNIS01 MODULE INSTALLATION	3-7
INICT01 INFI-NET TO COMPUTER TRANSFER MODULE CONFIGURATION	3-8
Dipswitch Settings.....	3-9
Dipswitch U72 - Options	3-9
Dipswitch U73 - Serial Port Communication Rate	3-10
Dipswitch U75 - Diagnostics	3-11
INICT01 MODULE INSTALLATION	3-11
INICT03 INFI-NET TO COMPUTER TRANSFER MODULE CONFIGURATION	3-13
Dipswitch Settings.....	3-13
Dipswitch SW1 - Serial Port Communication Rate	3-14
Dipswitch SW2 - Diagnostics	3-14
Dipswitch SW3 - SCSI Port	3-14
Dipswitch SW4 - Options	3-15
Jumper Settings	3-16
HW SETUP Socket Jumper	3-17
IMMPI01 MULTI-FUNCTION PROCESSOR INTERFACE MODULE CONFIGURATION ..	3-17
JUMPER SETTINGS.....	3-18
INICT03 AND IMPPI01 MODULE INSTALLATION	3-19
SECTION 4 - OPERATING PROCEDURES.....4-1	
INTRODUCTION	4-1
INNIS01 NETWORK INTERFACE SLAVE MODULE START-UP PROCEDURES	4-1
Event Counters	4-1
Error Counters	4-1
INICT01 INFI-NET TO COMPUTER TRANSFER MODULE LEDS AND CONTROLS	4-1
Status LED.....	4-2
CPU LEDs	4-2
Memory LEDs.....	4-2
Stop Switch	4-3
Reset Switch.....	4-3
INICT03 INFI-NET TO COMPUTER TRANSFER MODULE LEDS AND CONTROLS	4-4
Status LED.....	4-4
CPU LEDs	4-5
Stop/Reset Pushbutton	4-5
INICIO1 AND INICIO3 MODES OF OPERATION	4-5
Execute Mode	4-5
Error Mode	4-5
SECURITY FUNCTIONS	4-5
Hardware Checks	4-6
Software Checks	4-6
UTILITIES.....	4-6
TALK90 Option	4-6
Configure/View Callup Password Option	4-9
Computer Command/Reply Sequences Option	4-9
Set Local Time and Date Option	4-9
Monitor Mode Option	4-10
Real Value Conversion Option	4-10
Port Address Option	4-12
Dump On Halt Option	4-12
Time Sync Accuracy Option	4-12

Table of Contents (continued)

	<i>Page</i>
SECTION 5 - TROUBLESHOOTING	5-1
INTRODUCTION	5-1
ERROR COUNTERS	5-1
INNIS01 MODULE ERROR CODES	5-1
INICT01 AND INICT03 MODULE ERROR CODES	5-2
SECTION 6 - MAINTENANCE	6-1
INTRODUCTION	6-1
PREVENTIVE MAINTENANCE SCHEDULE	6-1
EQUIPMENT/TOOLS REQUIRED	6-2
PREVENTIVE MAINTENANCE PROCEDURES	6-2
Printed Circuit Board Cleaning	6-2
General Cleaning and Washing	6-3
Edge Connector Cleaning	6-3
Checking Connections	6-4
SECTION 7 - REPAIR/REPLACEMENT PROCEDURES	7-1
INTRODUCTION	7-1
MODULE REPLACEMENT PROCEDURE	7-1
TERMINATION UNIT OR MODULE REPLACEMENT PROCEDURES	7-2
SECTION 8 - SUPPORT SERVICES	8-1
INTRODUCTION	8-1
REPLACEMENT PARTS AND ORDERING INFORMATION	8-1
TRAINING	8-1
TECHNICAL DOCUMENTATION	8-1
APPENDIX A - NTCL01 TERMINATION UNIT CONFIGURATION	A-1
INTRODUCTION	A-1
APPENDIX B - NICL01 TERMINATION MODULE CONFIGURATION	B-1
INTRODUCTION	B-1
APPENDIX C - NTFM01 TERMINATION UNIT CONFIGURATION	C-1
INTRODUCTION	C-1
APPENDIX D - NIMF01/NIMF02 TERMINATION MODULE CONFIGURATION	D-1
INTRODUCTION	D-1
APPENDIX E - NTMP01 TERMINATION UNIT CONFIGURATION	E-1
INTRODUCTION	E-1
APPENDIX F - NIMP01/NIMP02 TERMINATION MODULE CONFIGURATION	F-1
INTRODUCTION	F-1

List of Figures

<i>No.</i>	<i>Title</i>	<i>Page</i>
1-1.	INICI01 and INICI03 INFI-NET to Computer Interfaces	1-2
3-1.	INNIS01 Module Dipswitch and Jumper Locations	3-2
3-2.	INNIS01 Module Jumper Settings	3-7
3-3.	INICT01 Module CPU Circuit Board Dipswitch Locations	3-9
3-4.	INICT03 Module Dipswitch and Jumper Locations	3-13
3-5.	IMMPI01 Module Jumper Locations	3-18
3-6.	IMMPI01 Module Jumper J1 Settings	3-18
3-7.	IMMPI01 Module Jumper J2 Settings	3-19
4-1.	INNIS01 Module Faceplate LEDs	4-2
4-2.	INICT01 Module Faceplate LEDs and Controls	4-3
4-3.	INICT03 Module Faceplate LEDs and Controls	4-4
4-4.	Example INICT03 Module Utilities Menu	4-7
4-5.	Example INICT01 Module Utilities Menu	4-7
4-6.	Example TALK90 Command Menu	4-8
4-7.	RESTART and DEMAND MODULE STATUS Commands and Replies	4-10
4-8.	Example Time Utilities Menu	4-11
A-1.	NTCL01 Connector and Jumper Locations (Revision F or Greater)	A-1
A-2.	NTCL01 Coaxial Cable Connections to INNIS01 Modules	A-2
A-3.	NTCL01 Twinaxial Cable Connections to INNIS01 Modules	A-2
B-1.	NICL01 Connector and Jumper Locations (Revision D or Greater)	B-1
B-2.	NICL01 Coaxial Cable Connections to INNIS01 Modules	B-2
B-3.	NICL01 Twinaxial Cable Connections to INNIS01 Modules	B-2
C-1.	NTMF01 Dipshunt Configuration for Direct Connection to a Host Computer	C-1
C-2.	NTMF01 Dipshunt Configuration for Direct Connection to a Modem	C-2
C-3.	NTMF01 Dipshunt Configuration for Direct Connection to Mainframe Computer ...	C-3
C-4.	NTMF01 Dipshunt Configuration for Diagnostic Terminal	C-4
C-5.	NTMF01 DB-25 Connector Pin Assignments and RS-232-C Signals	C-5
D-1.	NIMF01/02 Dipshunt Configuration for Direct Connection to a Host Computer	D-1
D-2.	NIMF01/02 Dipshunt Configuration for Direct Connection to a Modem	D-2
D-3.	NIMF01/02 Dipshunt Configuration for Direct Connection to Mainframe Computer.....	D-3
D-4.	NIMF01/02 Dipshunt Configuration for Diagnostic Terminal	D-4
D-5.	NIMF01/02 DB-25 Connector Pin Assignments and RS-232-C Signals	D-5
E-1.	DTE Jumper Configuration for NTMP01 Termination Unit	E-1
E-2.	DCE Jumper Configuration for NTMP01 Termination Unit	E-2
E-3.	NTMP01 Nonhandshake Jumper Configuration	E-2
E-4.	NTMP01 Loopback Jumper Configuration	E-3
E-5.	NTMP01 Jumpers J3 through J10 Configuration	E-3
E-6.	NTMP01 Jumpers J14 through J17 Configuration	E-4
E-7.	NTMP01 Connector Assignments and Jumper Locations	E-4
F-1.	DTE Jumper Configuration for NIMP01 Termination Module	F-1
F-2.	DCE Jumper Configuration for NIMP01 Termination Module	F-2
F-3.	NIMP01 Nonhandshake Jumper Configuration	F-2
F-4.	NIMP01 Loopback Jumper Configuration	F-2
F-5.	NIMP01 Jumpers J5 through J10 Configuration	F-3
F-6.	NIMP01 Jumpers J14 through J17 Configuration	F-3
F-7.	NIMP01 Connector Assignments and Jumper Locations	F-4

List of Tables

<i>No.</i>	<i>Title</i>	<i>Page</i>
1-1.	Glossary of Terms and Abbreviations	1-6
1-2.	Reference Documents	1-6
1-3.	Nomenclature	1-7
1-4.	Specifications.....	1-7
3-1.	NNIS01 Module Dipswitch SW1 Settings	3-3
3-2.	INNIS01 Module Dipswitch SW2 Settings	3-3
3-3.	INNIS01 Module Dipswitch SW3 Settings	3-4
3-4.	INNIS01 Module Address Settings	3-5
3-5.	INNIS01 Module Event Counters	3-5
3-6.	INNIS01 Module Error Counters.....	3-6
3-7.	INICT01 Module Dipswitch U72 Settings	3-9
3-8.	INICT01 Module Dipswitch U73 Settings	3-10
3-9.	INICT01 Module Dipswitch U75 Settings	3-11
3-10.	INICT03 Module Dipswitch SW1 Settings	3-14
3-11.	INICT03 Module Dipswitch SW2 Settings	3-15
3-12.	INICT03 Module Dipswitch SW3 Settings	3-15
3-13.	INICT03 Module Dipswitch SW4 Settings	3-16
3-14.	INICT03 Module Jumpers J1, J2, J4 and J5 Settings	3-17
3-15.	INICT03 Module HW SETUP Socket Jumper Settings	3-17
4-1.	INICT01 Module Status LED States	4-3
4-2.	INICT03 Module Status LED States	4-4
5-1.	INNIS01 Module Error Codes	5-1
5-2.	INICT01 and INICT03 Module Error Codes	5-2
5-3.	INNIS01 Module Edge Connector P1 Pin Assignments	5-3
5-4.	INNIS01 Module Edge Connector P2 Pin Assignments	5-3
5-5.	INNIS01 Module Edge Connector P3 Pin Assignments	5-3
5-6.	INICT01 Module Edge Connector P1 Pin Assignment	5-4
5-7.	INICT01 Module Edge Connector P2 Pin Assignments	5-4
5-8.	INICT01 Module Edge Connector P3 Pin Assignments	5-4
5-9.	INICT03 Module Edge Connector P1 Pin Assignment	5-5
5-10.	INICT03 Module Edge Connector P2 Pin Assignments	5-5
5-11.	INICT03 Module Edge Connector P3 Pin Assignments	5-5
5-12.	IMMPI01 Module Edge Connector P1 Pin Assignment	5-6
5-13.	IMMPI01 Module Edge Connector P3 Pin Assignments	5-6
6-1.	Preventive Maintenance Schedule	6-2
8-1.	Spare Parts List	8-1
A-1.	NTCL01 Jumper Settings for Revision D and E.....	A-3
A-2.	NTCL01 Jumper Settings for Revision F or Greater	A-3
B-1.	NICL01 Jumper Settings for Revision C	B-3
B-2.	NICL01 Jumper Settings for Revision D or Greater	B-3

SECTION 1 - INTRODUCTION

OVERVIEW

INFI-NET is a unidirectional, high speed serial data highway shared by all INFI 90 nodes. INFI-NET utilizes sophisticated computer interfaces for data exchange. These computer interfaces use state-of-the-art INFI 90 modules.

INTENDED USER

Personnel installing, operating, or maintaining the INFI-NET to computer interfaces should read this manual before performing any installation, operation, or maintenance procedures. Installation requires an engineer or technician experienced handling electronic circuitry and familiar with communication networks.

COMPUTER INTERFACE DESCRIPTION

The computer interfaces are the INICIO1 and INICIO3 INFI-NET to Computer Interfaces. The INNISO1 Network Interface Slave Module (NIS) is a part of all INFI-NET to computer interfaces. It is the intelligent link between a node and the INFI-NET loop. The NIS module and other modules make up a specific computer interface. Refer to Figure 1-1.

INICIO1 INFI-NET to Computer Interface

The INICIO1 INFI-NET to Computer Interface (ICI) is made up of the NIS module and the INICT01 INFI-NET to Computer Transfer Module (ICT). This computer interface gives a host computer access to point data. Point data is available through an RS-232-C serial link at standard rates up to 19.2 kilobaud. The INFI-NET to computer interface is command driven through software on the host computer. The ICI computer interface receives a command from the host computer, executes it and then replies to the host computer.

INICIO3 INFI-NET to Computer Interface

The INICIO3 INFI-NET to Computer Interface (ICI) is made up of the NIS module, the INICT03 INFI-NET to Computer Transfer Module (ICT), and the IMMPIO1 Multi-Function Processor Interface Module (MPI). This computer interface gives a host computer access to point data. Point data is available through an RS-232-C serial link at rates up to 19.2 kilobaud or through a SCSI parallel port. The INFI-NET to computer interface is command driven through software on the host computer. The ICI computer interface receives a command from the host computer, executes it and then replies to the host computer.

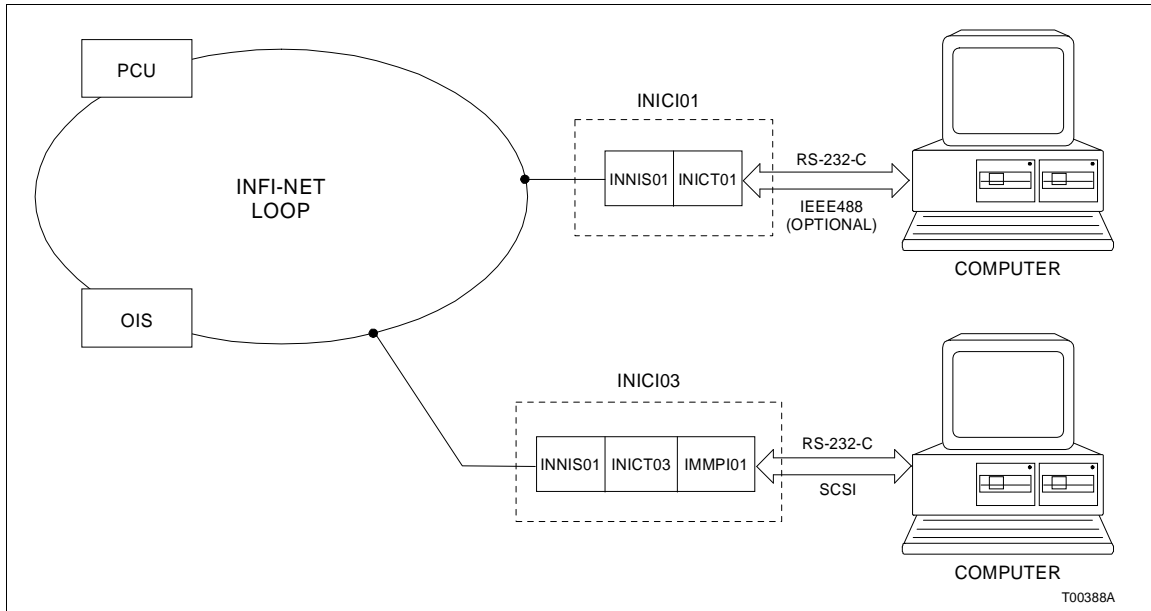

Figure 1-1. INICI01 and INICI03 INFI-NET to Computer Interfaces

MODULE DESCRIPTION

A description of each module used in the INICI01 and INICI03 INFI-NET to Computer Interfaces follows.

INNIS01 Network Interface Slave Module

The NIS module is an I/O module that works in conjunction with the other INFI-NET communication modules. This allows a node to communicate with any other node on the INFI-NET loop.

The NIS module is a single printed circuit board that occupies one slot in the module mounting unit. The circuit board contains microprocessor based communication circuitry that enables it to interface with other INFI-NET communication modules. All INFI-NET to computer interfaces require a specific communication module or modules and the NIS module.

Two latching screws on the faceplate secure the NIS module to the module mounting unit. There are sixteen LEDs on the faceplate that display error codes and event/error counts.

The NIS module has three card edge connectors for external signals and power (connector P1, P2 and P3). Connector P1 connects to common (ground) and +5 VDC power. Connector P2 connects the NIS module to the I/O expander bus to communicate with a control module within its node. Serial communication to other nodes is through connector P3 using a cable connected to a termination unit or termination module. Communication between nodes is through coaxial or twinaxial cables that connect the termination units or modules on each node.

INICT01 INFI-NET to Computer Transfer Module

The INICT01 INFI-NET to Computer Transfer Module (ICT) provides the electronics needed to direct the operation of the INICI01 INFI-NET to Computer Interface. It handles all communication with the host computer through RS-232-C serial communication ports (one or both) and communicates directly with the NIS module over the I/O expander bus.

The ICT module consists of two printed circuit boards. One circuit board is a memory board while the other is a central processing unit. These boards contain the serial communication circuitry necessary for the ICT module to communicate with a computer. The ICT module occupies two mounting unit slots adjacent to its associated NIS module.

Two latching screws on the ICT module faceplate secure the module in the module mounting unit. The faceplate contains eight CPU LEDs, two memory LEDs, a stop switch, and a reset switch.

The communication path to the computer is through a cable connection between connector P3 of the ICT module and a NTMF01 Multi-Function Controller Termination Unit or NIMF01 Multi-Function Controller Termination Module. Power and I/O expander bus connections follow the same connector assignments common to most INFI 90 modules (connector P1 for power, connector P2 for I/O expander bus).

INICT03 INFI-NET to Computer Transfer Module

The INICT03 INFI-NET to Computer Transfer Module (ICT) provides the electronics needed to direct the operation of the INICI03 INFI-NET to Computer Interface. It handles all communication with the host computer through the IMMPIO1 Multi-Function Processor Interface Module (MPI), RS-232-C (one or both) or SCSI communication ports. The ICT module also communicates directly with the NIS module over the I/O expander bus.

The ICT module consists of one printed circuit board. This board contains the communication circuitry necessary for the ICT module to communicate, through an MPI module, with a host computer. The ICT module occupies one module mounting unit slot adjacent to its associated NIS module and MPI module.

Two latching screws on the ICT faceplate secure the module in the module mounting unit. The faceplate contains 17 CPU LEDs and a stop/reset switch.

The host computer can be connected to the ICT module in one of two ways. One way is to connect a SCSI communication cable from the SCSI port on the MPI faceplate to the SCSI port on the host computer. The other way is to connect a NKTU01, NKTU02, NKTU11, or NKTU12 cable from the MPI module to the NTMP01 termination unit or NIMP01 termination module and then an RS-232-C communication cable from the termination device to the RS-232-C port on the host computer. Power and I/O expander bus connections follow the same connector assignments common to most INFI 90 modules (connector P1 for power, connector P2 for I/O expander bus).

IMMPI01 Multi-Function Processor Interface Module

The IMMPI01 Multi-Function Processor Interface Module (MPI) provides the INICT03 INFI-NET to Computer Transfer Module (ICT) with communication ports. It contains I/O ports (i.e., RS-232-C, SCSI) that the ICT module can use. The MPI module is an interface device that handles I/O to and from the ICT module. Control and data signals from the ICT module travel through a 60-pin ribbon cable to the MPI module.

The MPI module connects to an NTMP01 Multi-Function Processor Termination Unit or NIMP01 Multi-Function Processor Termination Module. Input and output signals enter or leave the MPI circuit board through a NKTU01, NKTU02, NKTU11, or NKTU12 cable to the termination device. The SCSI connection comes out of the faceplate for connection to a host computer.

FEATURES

The INFI-NET to computer interfaces have the following features:

- INFI-NET, which provides a plantwide communication network, is used.
- INFI-NET time synchronizes the control process plantwide.
- Each INFI-NET node can operate independently of other INFI-NET nodes.
- Computer interface modules provide localized start-up and shutdown on power failure without operator intervention.
- The 10-megabaud response rate gives timely information exchange.
- The ICT modules package process information for maximum transmission efficiency.

- The computer interface modules handle four message types: broadcast, time synchronization, multicast and NIS poll.
- All messages contain cyclic redundancy check codes (CRC) and checksums to ensure data integrity.

INSTRUCTION CONTENT

This manual consists of eight sections and six appendices.

Introduction	Provides an overview of the computer interfaces. It contains module descriptions, features, and specifications.
Description and Operation	Explains module operation.
Installation	Covers handling guidelines and explains how to configure the modules before placing them into operation.
Operating Procedures	Provides information about normal module operation.
Troubleshooting	Explains how to troubleshoot the modules using error codes and lists the corrective action.
Maintenance	Contains a maintenance schedule for the modules.
Repair/Replacement Procedures	Explains how to replace the modules.
Support Services	Explains the customer training Bailey Controls Company provides and information about ordering replacement parts.
Appendices	Provides information on termination unit and module configuration.

HOW TO USE THIS MANUAL

Read this manual in sequence. It is important to become familiar with the entire contents of this manual before using the modules. This manual is organized to enable quick information retrieval.

1. Read and perform all steps in **Section 3**.
2. Thoroughly read **Section 4** before applying power to the computer interfaces.
3. Refer to **Section 5** if a problem occurs. This section will help to diagnose and correct a problem.
4. Refer to **Section 6** for scheduled maintenance requirements.

5. Go to **Section 7** to find instructions on how to replace a module.
6. Refer to **Section 8** for a list of replacement parts and warranty information.

GLOSSARY OF TERMS AND ABBREVIATIONS

Table 1-1 lists the terms and abbreviations used in this instruction that are unique to Bailey Controls Company.

Table 1-1. Glossary of Terms and Abbreviations

Term	Definition
Checksum	A value computed from a data stream by treating each element as a number and computing a sum of the elements.
Exception Report	Information update generated when the status or value of a point changes by more than a specified significant amount; abbreviated as XR.
Node	A point of interconnection to a network.
NVRAM	Nonvolatile random access memory. Retains stored information when power is removed.
Termination Module	Provides input/output connection between plant equipment and the INFI 90/ Network 90 [®] modules.
Termination Unit	Provides input/output connection between plant equipment and the INFI 90/ Network 90 modules.

REFERENCE DOCUMENTS

Table 1-2 lists the documents that provide additional information for related hardware/software. Refer to them as needed.

Table 1-2. Reference Documents

Number	Document
I-E96-200	Function Code Applications Manual
I-E96-401	NIMP01/02 Multi-Function Processor Termination Module
I-E96-408	NICL01 Communication Termination Module
I-E96-413	NIMF01/02 Multi-Function Controller Termination Module
I-E96-422	NTCL01 Communication Termination Unit
I-E96-427	NTMF01 Multi-Function Controller Termination Unit
I-E96-428	NTMP01 Multi-Function Processor Termination Unit

NOMENCLATURE

Table 1-3 lists the nomenclatures of the modules and associated equipment used in this instruction.

[®] Network 90 is a registered trademark of Eltag Bailey Process Automation.

Table 1-3. Nomenclature

Nomenclature	Hardware/Description
IEMMU01/02	Module mounting unit
INICI01	INFI-NET to computer interface
INICT01	Requires modules:
INNIS01	INFI-NET to computer transfer module
	Network interface slave module
INICI03	INFI-NET to computer interface
IMMPI01	Requires modules:
INICT03	Multi-function processor interface module
INNIS01	INFI-NET to computer transfer module
	Network interface slave module
NFTP01	Field termination panel
NICL01	Communication termination module
NIMF01	Multi-function controller termination module
NIMF02	Redundant multi-function controller termination module
NIMP01	Multi-function processor termination module
NKLS01/11	Termination cable, INNIS01 to NTCL01
NKLS02/12	Termination cable, INNIS01 to NICL01
NKTU01/11	Termination cable, INICT01 to NTMF01 or IMPPI01 to NTMP01
NKTU02/12	Termination cable, IMPPI01 to NIMP01
NTCL01	Communication termination unit
NTMF01	Multi-function controller termination unit
NTMP01	Multi-function processor termination unit
NTMU01/02	Termination mounting unit

SPECIFICATIONS

Refer to Table 1-4 for the specifications of the modules making up the INFI-NET to Computer Interfaces.

Table 1-4. Specifications

Property	Characteristic/Value
IMMPI01	
Communication Ports	Two RS-232-C and one SCSI
Power Requirements	+5 VDC @ 415 mA; 2.08 W typical
Mounting	Occupies one slot in a standard INFI 90 module mounting unit
INNIS01	
Memory	208 kbytes RAM 64 kbytes ROM

Table 1-4. Specifications (continued)

Property	Characteristic/Value
INNIS01 (continued)	
Power Requirements	+5 VDC @ 900 mA; 4.50 W typical +15 VDC @ 5 mA; 0.08 W typical -15 VDC @ 200 mA; 3.00 W typical
System Capability	62,500 nodes in the system; 250 nodes on a loop. Any combination of PCU, MCS, OIS, or ICI interfaces.
Communication Rates	2 Mbaud or 10 Mbaud
Mounting	Occupies one slot in standard INFI 90 module mounting unit.
INICT01	
Ports	Two full duplex serial EIA standard RS-232-C
Memory	256 kbytes ROM 512 kbytes RAM 80 kbytes NVRAM
Power Requirements	+5 VDC @ 4.2 A; 21 W typical +15 VDC @ 40 mA; 0.6 W typical -15 VDC @ 20 mA; 0.3 W typical
Communication Rates	50 to 19,200 baud (user-selectable)
Mounting	Occupies two slots in standard INFI 90 module mounting unit
INICT03	
Memory	512 kbytes ROM 2 Mbytes RAM
Power Requirements	+5 VDC @ 1.958 A; 9.8 W typical
Communication Rates	50 to 19,200 baud (user-selectable) or 4 Mbytes/sec (SCSI port)
Mounting	Occupies one slot in standard INFI 90 module mounting unit
All INFI-NET Communication Modules	
Electromagnetic/Radio Frequency Interference	Values not available at this time. Keep cabinet doors closed. Do not use communication equipment any closer than 2 meters from the cabinet.
Ambient Temperature	0° to 70°C (32° to 158°F)
Relative Humidity	0% to 95% up to 55°C (131°F)(noncondensing) 0% to 45% above 55°C (131°F)(noncondensing)
Atmospheric Pressure	Sea level to 3 km (1.86 mi.)
Air Quality	Noncorrosive
Certification	The INFI-NET to computer interface modules are CSA certified for use as process control equipment in an ordinary (nonhazardous) environment. The INFI-NET to computer interface modules are Factory Mutual approved for use in Class I, Division 2, hazardous locations.

SPECIFICATIONS SUBJECT TO CHANGE WITHOUT NOTICE.

SECTION 2 - DESCRIPTION AND OPERATION

INTRODUCTION

INFI-NET is a unidirectional, high-speed serial data highway that can be used by all INFI 90 modules. The INNISO1 Network Interface Slave Module (NIS) and the INICT01 INFI-NET to Computer Transfer Module make up the INICIO1 INFI-NET to Computer Interface. The NIS module, INICT03 INFI-NET to Computer Transfer Module, and the IMMPIO1 Multi-Function Processor Interface Module make up the INICIO3 INFI-NET to Computer Interface.

MODULE INTEGRITY

All INFI-NET communication modules have normal INFI 90 security functions that insure module integrity. The module hardware checks for illegal addresses and monitors the machine fault timer (MFT) and the I/O expander bus clock. If a module detects an illegal address, it generates a bus error and displays an error code on the faceplate LEDs. If the microprocessor fails to reset the MFT timer, it expires. When this happens, the communication module stops and the status LED turns red. Module hardware also monitors the I/O expander bus clock. If there is no clock signal, the module hardware generates an interrupt.

INNISO1 NETWORK INTERFACE SLAVE MODULE

The NIS module serves as an I/O module to both the INICT01 and INICT03 modules. While each computer interface uses different INFI-NET communication modules, the NIS module operates with each communication module in the same manner. This section provides an overview of INFI-NET communication module operating theory.

Exception Reports

Each INFI 90 module establishes exception reporting parameters for process inputs (points). Some examples of exception report parameters are high and low alarm limits, minimum and maximum report time intervals, and percent of change in span limits. When a point changes more than a given parameter, or an alarm state changes, the module generates an exception report.

The computer transfer module polls modules (via the Controlway or module bus) for exception reports, and packs the exception reports having a common node destination. Packing places all exception reports for a destination (or multiple destinations) into one message (of variable length). The NIS module

sends this message to other INFI-NET nodes. This process reduces the number of transmissions required, and adjusts the message size for maximum INFI-NET loop efficiency.

Exception reports can have data values in the following formats: Boolean, analog, digital and status report. Exception reports are time stamped to reflect their processing sequence.

The maximum and minimum report time parameters insure that an exception report is generated for static or rapidly changing data. The minimum report time parameter controls the quantity of exception reports a single rapidly changing point generates. The maximum report time parameter generates a periodic exception report of data items that do not change or change very slowly.

NOTE: If a point goes into or out of alarm, the time parameters are ignored and an exception report is generated immediately.

Messages

The NIS module processes four different message types. They are broadcast, time synchronization, multicast, and NIS poll.

BROADCAST

The NIS module generates a broadcast message when sending information to all system nodes. Typically, these messages announce changes in node status. Broadcast messages include NODE ONLINE, NODE OFFLINE, NODE RESTART and NODE BUSY.

TIME SYNCHRONIZATION

The time synchronization message is a high priority broadcast type of message. The NIS module services this message type immediately. Time synchronization provides a common system time base to be used for sequencing exception reports, accessing trend data, and display on a system console.

MULTICAST

A message that contains data for multiple destinations is a multicast message. This message can have from one to 64 destinations.

NIS POLL

The NIS poll message is a single destination message. The NIS module uses this message type to poll the operational status of another node.

MESSAGE FORMAT

Messages exist as frames of information. Each frame consists of a message control field that follows an information field. The

information field contains the message data. It can consist of multiple messages and vary in size to a maximum of 1,500 bytes. The control field contains time of origination, sequence, source, size, circulation count, message type, destinations, and checksum value.

The NIS module increments the circulation count field of all incoming messages. When a message count field reaches 256, the next message is discarded. This is useful in keeping retry and spurious message traffic to a minimum. The NIS module uses the message type to determine how to process the message. The checksum and cyclic redundancy check code fields verify data integrity.

MESSAGE TRANSMISSION

Any NIS module can transmit a message at any time without regard to the activities of any other NIS module on the system. Each NIS module can transmit and receive messages simultaneously. NIS module start-up or shutdown is local and requires no interaction with other NIS modules on the INFI-NET loop. Each NIS module receives all incoming messages and transmits a new stream of messages in a store and forward fashion to the next node. When there are no messages for the NIS module to transmit, the NIS module transmits flag characters (null packets) as the loop synchronizing condition to keep the receivers in lock.

NIS Data Integrity

There are three methods the NIS module uses to insure data integrity. They are retry logic, node status table, and polling.

RETRY LOGIC

If on the first message transmission the NIS module does not receive a positive or negative acknowledgment from the destination node, it retransmits the message eleven times. If after this series of retries there is still no response, the destination node is marked off-line and the NIS module informs other communication modules of the negative acknowledgment.

NODE STATUS TABLE

The NIS module maintains an internal table of system wide status's such as off-line and busy nodes. The NIS module relays node status changes to other communication modules. When the NIS module periodically polls nodes, it updates this table accordingly.

POLLING

The NIS module uses the information in its status table for polling purposes. As it scans the status table, it picks out

destinations targeted for multicast messages that have been marked off-line or busy. After polling the destination, the NIS module updates its table and forwards pertinent information to other communication modules.

INICT01 INFI-NET TO COMPUTER TRANSFER MODULE

The INICT01 INFI-NET to Computer Transfer Module (ICT) provides the electronics needed to direct the operation of the INFI-NET to Computer Interface. It handles all communication with the host computer through a RS-232-C serial communication port. It communicates directly with the NIS module over the I/O expander bus. When communicating through the serial port, the ICT module can act as data communication equipment (DCE) or data terminal equipment (DTE). The dip-shunt configuration on the termination unit (NTMF01) or module (NIMF01 or NIMF02) determines if this computer interface operates as DTE or DCE.

The ICT module has enough memory that it can store up to 10,000 point definitions (depending on point types). ICT module firmware enables the host computer to issue commands for data acquisition, process monitoring and control, and system functions (security, time and configuration control). The ICT module maintains the point table and interprets commands coming from the host computer. Thus, it directs all interaction between the host computer and the INFI-NET system.

The ICT module receives data from INFI 90 modules and then sorts, organizes, and stores it in its database. The NIS module receives frames from the INFI-NET system and passes them on to the ICT module for processing. The ICT module then sorts this incoming data, storing exception reports and incoming requests until the host computer is ready for the data. This buffering action allows the host computer to operate completely asynchronously to the INFI-NET loop. When the host is ready to process more data, it issues a command to the ICT module that forwards the data as a reply.

INICT03 INFI-NET TO COMPUTER TRANSFER MODULE

The INICT03 INFI-NET to Computer Transfer Module (ICT) also provides the electronics needed to direct the operation of the INICI03 INFI-NET to Computer Interface. It handles all communication with the host computer through the IMMPIO1 Multi-Function Processor Interface Module (MPI) SCSI or RS-232-C communication ports. When communicating through the RS-232-C serial port, the MPI module can act as data communication equipment (DCE) or data terminal equipment (DTE). The jumper configuration on the termination unit (NTMP01) or termination module (NIMP01 or NIMP02)

determines if this interface operates as DTE or DCE. It also communicates directly with the NIS module over the I/O expander bus.

The ICT module has enough memory that it can store up to 30,000 point definitions (depending on point types). ICT module firmware enables the host computer to issue commands for data acquisition, process monitoring and control, and system functions (security, time and configuration control). The ICT module maintains the point table and interprets commands coming from the host computer. Thus, it directs all interaction between the host computer and the INFI-NET system.

The ICT module receives data from INFI 90 modules and then sorts, organizes and stores the data in a database. The NIS module receives frames from the INFI-NET system and passes them on to the ICT module for processing. The ICT module then sorts this incoming data, storing exception reports and incoming requests until the host computer is ready for the data. This buffering action allows the host computer to operate completely asynchronously to the INFI-NET loop. When the host computer is ready to process more data, it issues a command to the ICT module that forwards the data as a reply.

The MPI module provides the ICT module with serial ports and a SCSI interface. It contains SCSI and RS-232-C I/O ports.

INFI-NET TO COMPUTER INTERFACE COMMANDS

The computer transfer modules receive a command from a host computer, perform the desired action, and then reply to the host computer. The computer interface uses over 80 commands for data acquisition, process monitoring and control, and system functions (security, time, configuration). These commands fall into four basic command types: data acquisition, configuration, process control, and system status.

Data Acquisition

The host computer uses the ESTABLISH POINT and ESTABLISH REPORT commands to establish a database in the ICT modules. This database has the capacity for 10,000 points (INICI01) or 30,000 points (INICI03), depending on point types. The host computer has access to the ICT module database through data acquisition commands. Any trend block configured in the system can be read through the TREND DATA POLL command.

Configuration

The computer interfaces can be used to download control strategy configurations to INFI 90 modules. Also, the TUNE BLOCK and READ BLOCK OUTPUT commands are used to tune and monitor outputs.

Process Control

The command list provides process control abilities for the host computer. The host computer is able to handle analog and digital process requirements such as changing setpoints and control outputs, supplying data values to INFI 90 module blocks as exception reports, controlling and setting digital remote switches and constants.

System Status

Time synchronization is a critical function of the computer interfaces and part of overall status. It enables the host computer to set and display system time and date, and provides a mechanism for relating the time stamp to system time and date. The host computer is able to monitor individual module statuses and provide password protection.

SECTION 3 - INSTALLATION

INTRODUCTION

This section explains what must be done before placing any INFI-NET to computer interface modules into operation. Read, understand, and complete the steps in the order they appear before operating the modules.

SPECIAL HANDLING

Observe these steps when handling electronic circuitry:

NOTE: Always use Bailey Controls field static kit (part number 1948385_1 - consisting of two wrist straps, ground cord assembly, alligator clip, and static dissipating work surface) when working with the modules. The kit is designed to connect the technician and the static dissipating work surface to the same ground point to prevent damage to the modules by electrostatic discharge.

1. **Use Static Shielding Bag.** Keep the modules in the static shielding bag until you are ready to install them in the system. Save the packaging for future use.
2. **Ground Bags before Opening.** Before opening a bag containing an assembly with semiconductors, touch it to the equipment housing or a ground to equalize charges.
3. **Avoid Touching Circuitry.** Handle assemblies by the edges; avoid touching the circuitry.
4. **Avoid Partial Connection of Semiconductors.** Verify that all devices connected to the module are properly grounded before using them.
5. **Ground Test Equipment.**
6. **Use Antistatic Field Service Vacuum.** Remove dust from the module if necessary.
7. **Use a Grounded Wrist Strap.** Connect the wrist strap to the appropriate grounding plug on the power entry panel. The grounding plug on the power entry panel is connected to the cabinet chassis ground.
8. **Do Not Use Lead Pencils to Set Dipswitches.** To avoid contamination of dipswitch contacts that can result in unnecessary circuit board malfunction, do not use a lead pencil to set a dipswitch.

UNPACKING AND INSPECTION

1. Examine the hardware immediately for shipping damage.
2. Notify the nearest Bailey Controls sales office of any such damage.
3. File a claim for any damage with the transportation company that handled the shipment.
4. Use the original packing material and container to store the hardware.
5. Store the hardware in an environment of good air quality, free from temperature and moisture extremes.

INNIS01 NETWORK INTERFACE SLAVE MODULE CONFIGURATION

Both INFI-NET to computer interfaces require an INNIS01 Network Interface Slave Module (NIS). Configure the NIS module as follows.

Dipswitch Settings

There are four dipswitches on the NIS module. The dipswitches and their functions are described below. See Figure 3-1 for dipswitch locations.

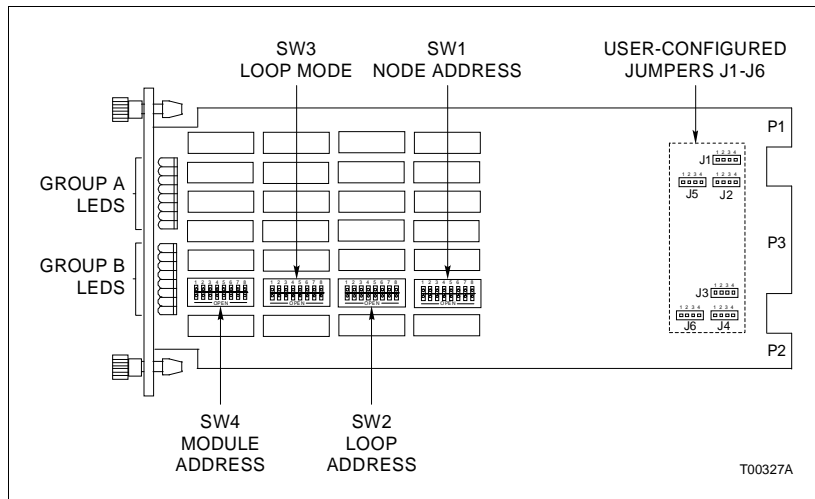

Figure 3-1. INNIS01 Module Dipswitch and Jumper Locations

DIPSWITCH SW1 - NODE ADDRESS

This dipswitch sets the node address. Valid node addresses are one through 250. Refer to Table 3-1. Pole one is the MSB bit with a binary weight of 128. Pole eight is the LSB bit with a binary weight of one. Record the dipswitch SW1 settings in the space provided.

Table 3-1. NNIS01 Module Dipswitch SW1 Settings

Address Example	Dipswitch Position (Binary Value)							
	1 (128)	2 (64)	3 (32)	4 (16)	5 (8)	6 (4)	7 (2)	8 (1)
1	0	0	0	0	0	0	0	1
64	0	1	0	0	0	0	0	0
250	1	1	1	1	1	0	1	0
User Setting								

NOTE: 0 = CLOSED (ON), 1 = OPEN (OFF).

DIPSWITCH SW2 - LOOP ADDRESS

This dipswitch sets the loop number of the loop off of the main INFI-NET loop. Valid loop numbers are one through 250. Refer to Table 3-2. Record the dipswitch SW2 setting in the space provided.

Table 3-2. INNIS01 Module Dipswitch SW2 Settings

Address Example	Dipswitch Position (Binary Value)							
	1 (128)	2 (64)	3 (32)	4 (16)	5 (8)	6 (4)	7 (2)	8 (1)
1	0	0	0	0	0	0	0	1
64	0	1	0	0	0	0	0	0
250	1	1	1	1	1	0	1	0
User Setting								

NOTE: 0 = CLOSED (ON), 1 = OPEN (OFF).

DIPSWITCH SW3 - LOOP MODE

Dipswitch SW3 enables or disables ROM checksums, identifies the loop as a Plant Loop or INFI-NET loop, identifies the NIS module in a node, and sets the loop communication speed to 500 kilobaud (Plant Loop), 2 megabaud (INFI-NET) or 10 megabaud (INFI-NET). Refer to Table 3-3. Record the dipswitch SW3 settings in the space provided.

Dipswitch SW3 pole one determines network processing module compatibility. Set pole one to the one position for a node

Table 3-3. INNIS01 Module Dipswitch SW3 Settings

Pole	Setting	Function	User Setting
1	1	This NIS module is part of a network to network connecting device.	
	0	This NIS module is part of a PCU or ICI interface.	
2	1	ROM checksumming enabled.	
	0	ROM checksumming disabled.	
3	1	Test mode: no time-out for handshake failure.	
	0	Normal operating mode.	
4 ¹	1	All loop messages return a busy negative acknowledgement.	
	0	Normal operating mode.	
5	1	Group A LEDs will toggle on and off if loop 1 is idle or shorted. Group B LEDs will toggle on and off if loop 2 is idle or shorted. Normal display otherwise.	
	0	LED display as defined by dipswitch SW4.	
6 ¹	1	Diagnostic mode.	
	0	Normal operating mode.	
7/8	0/0	10 Mbaud INFI-NET mode.	
	0/1	2 Mbaud INFI-NET mode.	
	1/0	Unused.	
	1/1	500 kbaud Plant Loop mode.	

NOTE: 0 = CLOSED (ON), 1 = OPEN (OFF); shaded areas designate normal operating positions.
 1. Applies to modules with revision B or later ROMs. For modules with revision A ROMs, poles 4 through 6 must be set to 0.

that connects two loops. Set pole one to zero for all other node types. Pole two enables or disables ROM checksumming. Bailey recommends that the NIS be installed with checksumming enabled to take full advantage of the on-board diagnostics. Pole three enables internal testing which must be disabled for normal operation. Pole four, in conjunction with pole three, makes the node appear to be busy to other nodes. Pole five enables the channel idle condition display for the front panel LEDs. If channel one is idle, the group A LEDs will flash on and off about twice per second. If channel two is idle, the group B LEDs will flash. The channel idle display is intended to serve as a warning that a loop integrity problem exists. Pole six enables diagnostic tests that preclude normal NIS module operation. Poles seven and eight determine loop speed and loop mode.

NOTE: Testing modes involving poles 3, 4 and 6 interfere with normal node operation.

DIPSWITCH SW4 - I/O MODULE ADDRESS AND COUNTERS

The NIS module can have an I/O address from zero to seven. Poles one through three of dipswitch SW4 set the I/O module address of the NIS module. Refer to Table 3-4 for I/O module address settings. Poles four through eight set the address of the on-board event and error counters that the NIS module

displays using the group A and B faceplate LEDs. Table 3-5 lists the event counters. Table 3-6 lists the error counters. Record the dipswitch SW4 settings in the space provided.

Example of Counter Usage

Counter 0A keeps track of the number of multicast messages received excluding those originated. To display this counter on the front panel LEDs, set dipswitch SW4 as follows: pole four = zero, five = one, six = zero, seven = one, and eight = zero.

Table 3-4. INNIS01 Module Address Settings

Address Example	Dipswitch Position (Binary Value)		
	1 (4)	2 (2)	3 (1)
0	0	0	0
3	0	1	1
7	1	1	1
User Setting			

NOTE: 0 = CLOSED (ON), 1 = OPEN (OFF).

Table 3-5. INNIS01 Module Event Counters

Dipswitch Position (Binary Value)	Hexadecimal Value	Description
4 5 6 7 8 (16) (8) (4) (2) (1)		
0 0 0 0 0	00	Number of timer interrupts.
0 1 0 0 1	09	Number of multicast messages received (excluding originated messages).
0 1 0 1 0	0A	Number of multicast destinations received.
0 1 0 1 1	0B	Number of time sync messages received (excluding originated messages).
0 1 1 0 0	0C	Number of broadcast messages received (excluding originated messages).
0 1 1 0 1	0D	Number of NIS poll messages received (excluding originated messages).
0 1 1 1 0	0E	Number of poll messages acknowledged by this node.
0 1 1 1 1	0F	Number of poll messages busy-not acknowledged by this node.
1 0 0 0 0	10	Number of messages transmitted (total loop traffic).
1 0 0 0 1	11	Number of loop messages received and forwarded by this node.
1 0 0 1 0	12	Number of messages originated by this node (including retries).
1 0 0 1 1	13	Number of message retries originated by this node.
1 0 1 0 0	14	Number of transmitted message watchdog expirations.

Table 3-5. INNIS01 Module Event Counters (continued)

Dipswitch Position (Binary Value)	Hexadecimal Value	Description
4 5 6 7 8 (16) (8) (4) (2) (1)		
1 0 1 0 1	15	Number of messages put into the receive buffer and retained.
1 0 1 1 0	16	Number of bytes originated by this node (including retries).
1 0 1 1 1	17	Number of bytes received and forwarded by this node.
1 1 0 0 0	18	Number of I/O expander bus to NIS module handshakes.
1 1 0 0 1	19	Number of I/O expander bus to transmit buffer signals.
1 1 0 1 0	1A	Number of I/O expander bus PCU status requests.
1 1 0 1 1	1B	Number of I/O expander bus NIS module status requests.
1 1 1 0 0	1C	Number of I/O expander bus interrupts with invalid status.
1 1 1 0 1	1D	Number of transmit buffer realignments due to invalid contents.
1 1 1 1 0	1E	Number of receive buffer realignments.
1 1 1 1 1	1F	Number of status buffer realignments.
		User Setting

NOTE: 0 = CLOSED (ON), 1 = OPEN (OFF); shaded areas designate normal operating positions.

Table 3-6. INNIS01 Module Error Counters

Dipswitch Position (Binary Value)	Hexadecimal Value	Description
4 5 6 7 8 (16) (8) (4) (2) (1)		
0 0 0 0 1	01	Number of channel 1 receive errors.
0 0 0 1 0	02	Number of channel 2 receive errors.
0 0 0 1 1	03	Number of transmitter errors.
0 0 1 0 0	04	Number of messages lost to receive queue overflow.
0 0 1 0 1	05	Number of messages dumped with circulation count errors.
0 0 1 1 0	06	Number of messages dumped with destination count or message-type errors.
0 0 1 1 1	07	Number of messages dumped with source-state errors.
0 1 0 0 0	08	Number of messages dumped with source-sequence mismatch.
		User Setting

NOTE: 0 = CLOSED (ON), 1 = OPEN (OFF).

Jumper Settings

There are six jumpers on the NIS module that set the communication rate of the receiver analog circuit. See Figure 3-1 for jumper locations. All six jumpers must be set in the same position. Jumper setting instructions are silk screened on the upper left corner of the NIS circuit board. The jumper setting

must match the communication rate set by poles seven and eight of dipswitch SW3. Figure 3-2 shows which pins to jumper for various loop modes. This figure shows placement of the pins when looking at the top of the NIS circuit board with the faceplate on the left.

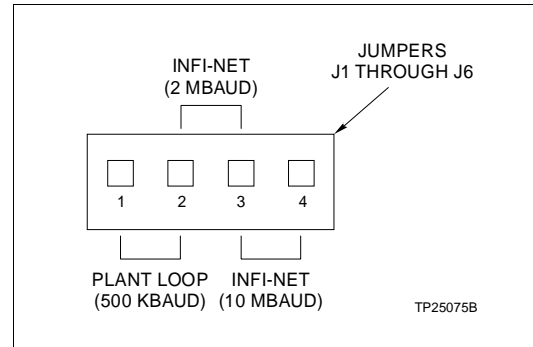

Figure 3-2. INNIS01 Module Jumper Settings

Power System Status

The communication system provides a means to monitor the status of the power system of each node. This status information can be displayed on the operator console. Electronics within the power entry panel monitor the power system status. A single status output is made available to the communication system. To use this feature, wire the status output to the terminal block on the termination device labeled PSS1 or PSS2. Two sets of terminals are available on each termination device for daisy chaining the power system status output.

This power system status signal is fed through the termination device cable to the P3 connector on the NIS module. The power system status input is a TTL-compatible signal. A high voltage level on power system status indicates good status. A low voltage level indicates bad status. When no connection is made to either of the power system status inputs, a pull-up resistor on the NIS module causes a high level signal on the power system status input, thereby reporting good status.

INNIS01 MODULE INSTALLATION

If the NIS module is properly configured, it is ready to be installed in the module mounting unit. To install the NIS module:

1. Verify the NIS module slot assignment in the module mounting unit.

WARNING

Disconnect power before installing dipshunts on the module mounting unit backplane. Failure to do so will result in contact with cabinet areas that could cause severe or fatal shock.

AVERTISSEMENT

Interrompez l'alimentation avant d'installer des dipshunts sur le fond de panier du châssis de montage des modules. Sinon, tout contact avec cette zone entraîne des risques d'électrocution sérieuse ou fatale.

2. Verify that a 24-pin dipshunt is installed in the I/O expander bus sockets between the module mounting unit slot to be used by the NIS module and the slot to be used by the INICT01 or INICT03 module.

NOTE: When installing the NIS module with an INICT01 module, there must be continuity between the NIS module and the CPU circuit board of the INICT01 module. When installing the NIS, IMMPIO1 and INICT03 modules, there must be continuity between the NIS and INICT03 modules.

3. Remove any 24-pin dipshunts from the I/O expander bus sockets that would connect the NIS module to any module other than the INICT01, INICT03, or IMMPIO1 module.

4. Attach the hooded end of the NKLS01, NKLS02, NKLS11, or NKLS12 cable to the module mounting unit backplane cable connector opening for the NIS module.

5. Slide the NIS module in while guiding the top and bottom edges of the circuit board along the top and bottom rails of the module mounting unit.

6. Push on the faceplate until the rear edge of the module is firmly seated in the backplane connector.

7. Turn the two latching screws $\frac{1}{2}$ turn to lock the module in place. The module is locked into place when the open side of the slot on the latching screws face the center of the faceplate.

Refer to the NTCL01 termination unit or NICL01 termination module manual for complete termination device information. **Appendix A** and **B** provide quick reference information about these termination devices.

INICT01 INFI-NET TO COMPUTER TRANSFER MODULE CONFIGURATION

Install one INICT01 INFI-NET to Computer Transfer Module (ICT) with one NIS module to make an INICIO1 INFI-NET to Computer Interface.

Dipswitch Settings

The INICT01 module consists of two circuit boards (a memory circuit board and a CPU circuit board). The memory board has no user-configurable operating options. The CPU circuit board has three dipswitches that set the module operating characteristics. These dipswitches select module operation options, serial port communication characteristics and baud rate. Figure 3-3 shows the dipswitch locations on the CPU circuit board.

NOTE: Jumpers J1 through J3 are factory set. Do not change the jumper settings.

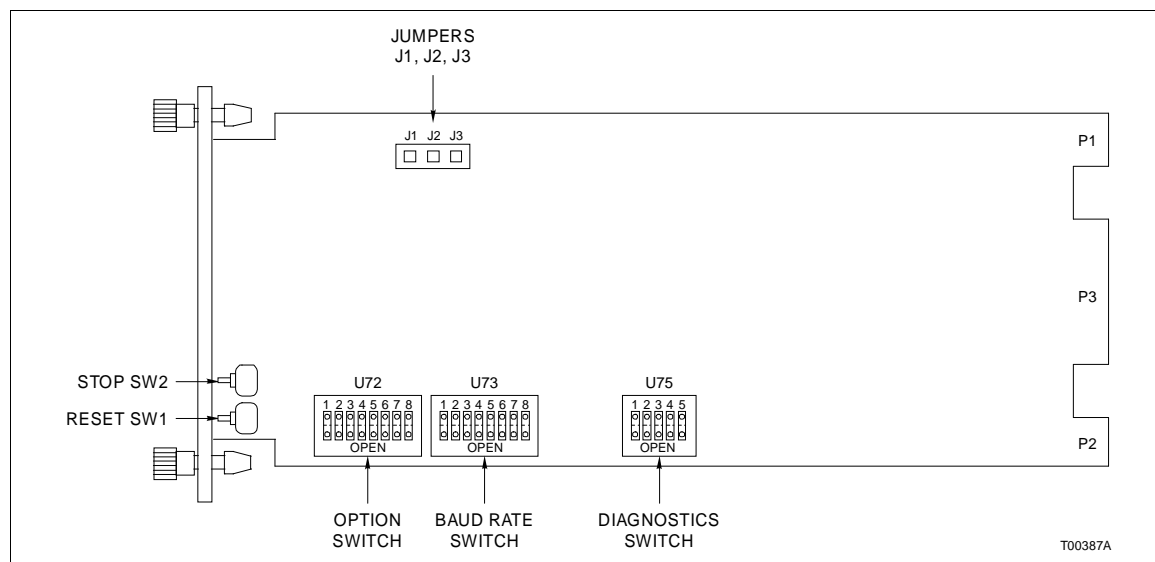

Figure 3-3. INICT01 Module CPU Circuit Board Dipswitch Locations

DIPSWITCH U72 - OPTIONS

Dipswitch U72 is an eight pole dipswitch that determines the operating options of the ICT module. Table 3-7 lists the dipswitch U72 option settings. Record the dipswitch U72 settings in the space provided.

Table 3-7. INICT01 Module Dipswitch U72 Settings

Pole	Setting	Function	User Setting
1	1	ROM checksumming disabled.	
	0	ROM checksumming enabled.	
2/3		Ports 0 and 1 data characteristics.	
	0/0	8 data bits, 1 stop bit, no parity.	
	0/1	8 data bits, 1 stop bit, even parity.	
	1/0	8 data bits, 1 stop bit, odd parity.	
	1/1	8 data bits, 2 stop bits, no parity.	

Table 3-7. INICT01 Module Dipswitch U72 Settings (continued)

Pole	Setting	Function	User Setting
4	1	Port 1 utility option.¹	
	0	Port 1 option serial port to host computer.	
5	1	Modem password protection enabled.	
	0	Modem password protection disabled.	
6	1	Port addressing mode enabled. ²	
	0	Port addressing mode disabled.	
7	1	Checksumming option enabled.³	
	0	Checksumming option disabled.	
8	N/A	Unused.	

NOTES: 0 = CLOSED (ON), 1 = OPEN (OFF); shaded areas designate normal operating positions.

1. Selecting this option automatically overrides dipswitch positions 2 and 3 and sets port 1 data characteristics to 8 data bits, 1 stop bit, and no parity bit. Dipswitch poles 2 and 3 retain full functionality when this option is not selected.

2. When this option is enabled, the ICT module expects all commands from the host computer to send the port address configured through the utilities menu as the first character of each command.

3. When this option is enabled, the ICT module expects all commands from the host computer to include a checksum byte as the last character before the carriage return. The ICT module includes a checksum in each reply.

DIPSWITCH U73 - SERIAL PORT COMMUNICATION RATE

Dipswitch U73 is an eight pole dipswitch that sets the serial port (RS-233-C) communication rate. The communication rate directly affects data throughput. Refer to Table 3-8 for communication rates. Record the dipswitch U73 settings in the space provided.

Table 3-8. INICT01 Module Dipswitch U73 Settings

Dipswitch Position				Baud Rate	Dipswitch Position			
Port 0		Port 1			Port 0		Port 1	
1	2	3	4		1	2	3	4
0	0	0	0	50				
1	0	0	0	75				
0	1	0	0	110				
1	1	0	0	134.5				
0	0	1	0	150				
1	0	1	0	300				
0	1	1	0	600				
1	1	1	0	1,200				

Table 3-8. INICT01 Module Dipswitch U73 Settings (continued)

Dipswitch Position				Baud Rate	Dipswitch Position					
Port 0		Port 1			Port 0		Port 1			
1	2	3	4		1	2	3	4		
0	0	0	1	0	0	0	1	1,800		
1	0	0	1	1	0	0	1	2,000		
0	1	0	1	0	1	0	1	2,400		
1	1	0	1	1	1	0	1	3,600		
0	0	1	1	0	0	1	1	4,800		
1	0	1	1	1	0	1	1	7,200		
0	1	1	1	0	1	1	1	9,600		
1	1	1	1	1	1	1	1	19,200		

NOTE: 0 = CLOSED (ON), 1 = OPEN (OFF).

DIPSWITCH U75 - DIAGNOSTICS

Dipswitch U75 enables computer interface diagnostic functions that are meaningful to qualified Bailey Controls Company service personnel only. All poles on dipswitch U75 must be closed for normal operation. Table 3-9 shows the dipswitch settings. Verify that all poles on dipswitch U75 are set to zero (closed or on).

Table 3-9. INICT01 Module Dipswitch U75 Settings

Pole	Setting	Function
1	1	NIS module handshake time-out disabled.
	0	NIS module handshake time-out enabled.
2	1	NIS module diagnostics enabled.
	0	NIS module diagnostics disabled.
3	1	INFI-NET diagnostic utilities enabled.
	0	INFI-NET diagnostic utilities disabled.
4/5	0	Unused.

NOTE: 0 = CLOSED (ON), 1 = OPEN (OFF); shaded areas designate normal operating positions.

INICT01 MODULE INSTALLATION

If the ICT module is properly configured, it is ready to be installed in the module mounting unit. To install the ICT module:

1. Verify the ICT module slot assignment in the module mounting unit is adjacent to its associated NIS module.

WARNING

Disconnect power before installing dipshunts on the module mounting unit backplane. Failure to do so will result in contact with cabinet areas that could cause severe or fatal shock.

AVERTISSEMENT

Interrompez l'alimentation avant d'installer des dipshunts sur le fond de panier du châssis de montage des modules. Sinon, tout contact avec cette zone entraîne des risques d'lectrocution sérieuse ou fatale.

2. Verify that a 24-pin dipshunt is installed in the I/O expander bus sockets between the module mounting unit slot to be used by the NIS module and the slot to be used by the ICT module.

NOTE: When installing the NIS module with an ICT module, there must be continuity between the NIS module and the CPU circuit board of the ICT module. Observe the following:

- a. Install one dipshunt in the I/O expander bus socket between the NIS slot and ICT slot if the NIS module is mounted to the left of the ICT module.
- b. If the NIS module is mounted to the right of the ICT module, two dipshunts are required. Install one dipshunt between the NIS slot and ICT slot. Install the second dipshunt between the slots of the memory circuit board and the CPU circuit board of the ICT module.

3. Remove any 24-pin dipshunts from the I/O expander bus sockets that would connect the INICT01 module to any module other than the NIS module.

4. Attach the hooded end of the NKTU01, NKTU02, NKTU11, or NKTU12 cable to the module mounting unit backplane cable connector opening for the ICT module. The other end of the cable attaches to the termination device or to the termination mounting unit backplane.

5. Slide the ICT module in while guiding the top and bottom edges of the circuit boards along the top and bottom rails of the module mounting unit.

6. Push on the faceplate until the rear edges of the module are firmly seated in the backplane connectors.

7. Turn the 2 latch screws $\frac{1}{2}$ turn to lock the module in place. The module is locked into place when the open end of the slot on the latching screws face the center of the faceplate.

Refer to the NTMF01 termination unit or NIMF01 and NIMF02 termination module instruction for complete termination device information. **Appendix C** and **D** provide quick reference information about these termination devices.

INICT03 INFI-NET TO COMPUTER TRANSFER MODULE CONFIGURATION

Install one INICT03 INFI-NET to Computer Transfer Module (ICT), one IMMPIO1 Multi-Function Processor Interface Module (MPI), and one NIS module to make an INICIO3 INFI-NET to Computer Interface.

NOTE: The INICT03 module uses connections to the module mounting unit backplane that served other functions in early Network 90 systems. To avoid potential module damage, evaluate your system for compatibility prior to module installation:

Early Network 90 systems applied -30 VDC to pins 3 and 4 of the module connector P1. This voltage is not required for INFI 90 modules. In INFI 90 systems, pin 4 is used for the Controlway bus.

If your system contains modules that require -30 VDC, set jumper J5 to the 30 VDC position. Doing so allows the installation of the ICT module in a module mounting unit that uses -30 VDC and limits communication to the module bus.

Dipswitch Settings

The ICT module consists of one circuit board. The board has four dipswitches. These dipswitches select module operation options, serial port communication characteristics and baud rate. Figure 3-4 shows the dipswitch locations. Module placement within the module mounting unit is important when installing an ICT module with the MPI module. Installing an MPI module with the ICT module requires two adjacent slots in a module mounting unit. The ICT module must occupy the right slot (when facing the front of the module mounting unit) and the MPI module must occupy the left slot.

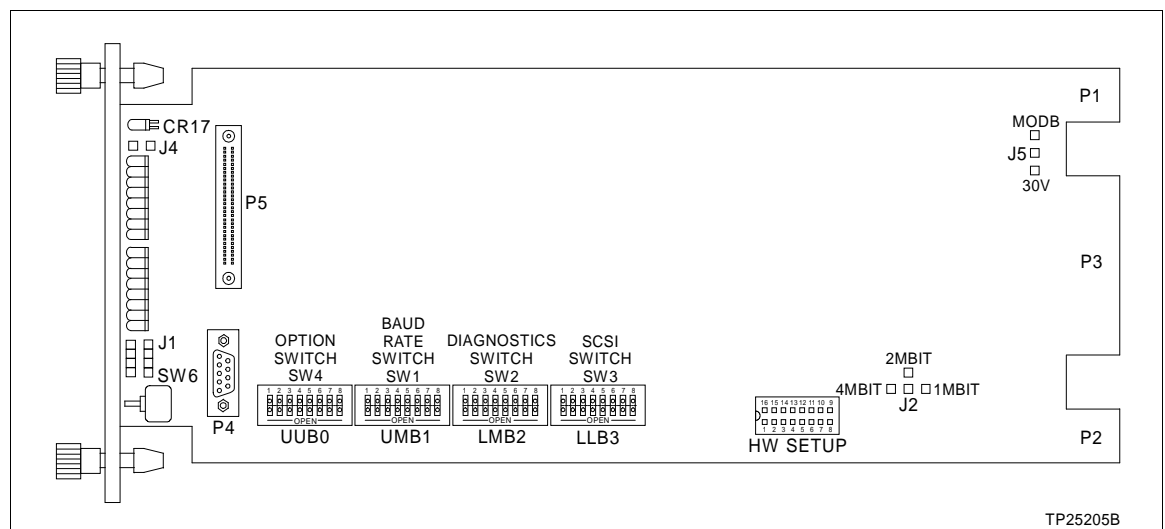

Figure 3-4. INICT03 Module Dipswitch and Jumper Locations

DIPSWITCH SW1 - SERIAL PORT COMMUNICATION RATE

Dipswitch SW1 is an eight pole dipswitch that sets the serial port (RS-232-C) communication rate. The communication rate directly affects data throughput. Refer to Table 3-10 for communication rates. Record the dipswitch SW1 settings in the space provided.

Table 3-10. INICT03 Module Dipswitch SW1 Settings

Dipswitch Position				Baud Rate	Dipswitch Position			
Port 0		Port 1			Port 0		Port 1	
1	2	3	4		5	6	7	8
0	0	0	0	50				
1	0	0	0	75				
0	1	0	0	110				
1	1	0	0	134.5				
0	0	1	0	150				
1	0	1	0	300				
0	1	1	0	600				
1	1	1	0	1,200				
0	0	0	1	1,800				
1	0	0	1	2,000				
0	1	0	1	2,400				
1	1	0	1	3,600				
0	0	1	1	4,800				
1	0	1	1	7,200				
0	1	1	1	9,600				
1	1	1	1	19,200				

NOTE: 0 = CLOSED (ON), 1 = OPEN (OFF).

DIPSWITCH SW2 - DIAGNOSTICS

Dipswitch SW2 enables computer interface diagnostics that are meaningful to qualified Bailey Controls Company service personnel only. All poles on dipswitch SW2 must be closed for normal operation. Table 3-11 shows the dipswitch settings. Verify that all dipswitch poles on dipswitch SW2 are set to zero (closed or on).

DIPSWITCH SW3 - SCSI PORT

Dipswitch SW3 enables or disables the SCSI port and sets the SCSI port address. Table 3-12 shows the dipswitch settings. If the SCSI port is enabled, serial port 1 is disabled.

Table 3-11. INICT03 Module Dipswitch SW2 Settings

Pole	Setting	Function
1	1	NIS module handshake time-out disabled.
	0	NIS module handshake time-out enabled.
2	1	NIS module diagnostics enabled.
	0	NIS module diagnostics disabled.
3	1	INFI-NET diagnostic utilities enabled.
	0	INFI-NET diagnostic utilities disabled.
4	1	Hardware diagnostics enabled.
	0	Hardware diagnostics disabled.
5 - 7		Unused.

NOTE: 0 = CLOSED (ON), 1 = OPEN (OFF); shaded areas designate normal operating positions.

Table 3-12. INICT03 Module Dipswitch SW3 Settings

Pole	Setting	Function	User Setting
1	1	SCSI port enabled.	
	0	SCSI port disabled.	
2/3/4	0/0/0	Address = 0	
	0/0/1	Address = 1	
	0/1/0	Address = 2	
	0/1/1	Address = 3	
	1/0/0	Address = 4	
	1/0/1	Address = 5	
	1/1/0	Address = 6	
	1/1/1	Address = 7	
5	1	SCSI parity checking enabled.	
	0	SCSI parity checking disabled.	
6 - 8		Unused.	

NOTE: 0 = CLOSED (ON), 1 = OPEN (OFF).

DIPSWITCH SW4 - OPTIONS

Dipswitch SW4 is an eight-pole dipswitch that determines the operating options of the module. Table 3-13 lists the option settings. Record the dipswitch SW4 settings in the space provided.

Table 3-13. INICT03 Module Dipswitch SW4 Settings

Pole	Setting	Function	User Setting
1	1	ROM checksumming disabled.	
	0	ROM checksumming enabled.	
2/3		Ports 0 and 1 data characteristics.	
	0/0	8 data bits, 1 stop bit, no parity	
	0/1	8 data bits, 1 stop bit, even parity	
	1/0	8 data bits, 1 stop bit, odd parity	
	1/1	8 data bits, 2 stop bits, no parity	
4	1	Port 1 utility option.¹	
	0	Port 1 option serial port to host computer.	
5	1	Modem password protection enabled.	
	0	Modem password protection disabled.	
6	1	Port addressing mode enabled. ²	
	0	Port addressing mode disabled.	
7	1	Checksumming option enabled.³	
	0	Checksumming option disabled.	
8	N/A	Unused.	

NOTES: 0 = CLOSED (ON), 1 = OPEN (OFF); shaded areas designate normal operating positions.

1. Selecting this option automatically overrides dipswitch poles 2 and 3 and sets port 1 data characteristics to 8 data bits, 1 stop bit, and no parity bit. Dipswitch poles 2 and 3 retain full functionality when this option is not selected.

2. When this option is enabled, the ICT module expects all commands from the host computer to send the port address configured through the utilities menu as the first character of each command.

3. When this option is enabled, the ICT module expects all commands from the host computer to include a checksum byte as the last character before the carriage return. The ICT module includes a checksum in each reply.

Jumper Settings

CAUTION

Never operate the ICT module with the machine fault timer circuit disabled (jumper pins connected). Unpredictable module outputs may result. These unpredictable module outputs may adversely affect the entire communication system.

ATTENTION

Ne jamais faire fonctionner le module ICT alors que le circuit MFT (Machine Fault Timer) est hors-circuit. Il pourrait en résulter des sorties imprévisibles. Ces sorties imprévisibles pourraient affecter très défavorablement le système entier de communication.

There are four jumpers (jumper J1, J2, J4, and J5) on the ICT module. These jumpers are for special ICT hardware applications. They define the RS-232-C diagnostic port as data terminal equipment (DTE) or data communication equipment (DTE), define the type of SRAM contained on the SRAM modules, enable the machine fault timer and enable the module to operate in a module mounting unit that uses -30 VDC. Refer to Table 3-14 for the jumper settings.

Table 3-14. INICT03 Module Jumpers J1, J2, J4 and J5 Settings

Jumper	Setting	Function	User Setting
J1	Vertical ¹	Set the RS-232-C diagnostic port to operate as DCE.	
	Horizontal	Set the RS-232-C diagnostic port to operate as DTE.	
J2 ²	4 - 3	1 Megabit SRAM device (128k x 8).	
	4 - 2	2 Megabit SRAM device (256k x 8).	
	4 - 1	4 Megabit SRAM device (512k x 8).	
J4	Open	Machine fault timer disabled. This jumper must remain open for normal operation.	
J5 ³	30V	Disconnects Controlway channel B for early Network 90 module mounting units (-30 VDC used).	
	MODB	Connects Controlway channel B for operation in module mounting units utilizing the Controlway.	

NOTES: Shaded areas designate normal operating positions.

1. This feature is used by Bailey Controls service personnel only. The jumper J1 setting does not affect the module during normal operation.
2. Defines the type of SRAM memory. Jumper J2 must be set to 4 - 3 for the current release.
3. This setting sets up the ICT module for operation in systems using early Network 90 modules that require -30 VDC.

HW SETUP Socket Jumper

The HW SETUP socket defines the number of SRAM memory banks installed and selects wait states for ROM and SRAM memory. Refer to Table 3-15 for the jumper settings.

Table 3-15. INICT03 Module HW SETUP Socket Jumper Settings

Socket Position	Jumper Settings
1 to 16	Install this jumper for INICT03 modules containing firmware revision level B.0. Remove this jumper for firmware revision levels greater than B.0.
2 to 15	Install this jumper for INICT03 modules containing firmware revision level C.0 or greater. Remove this jumper for firm-ware revision levels prior to C.0.
3 to 14	Open.
4 to 13	
5 to 12	
6 to 11	
7 to 10	
8 to 9	

IMMPI01 MULTI-FUNCTION PROCESSOR INTERFACE MODULE CONFIGURATION

The IMPPI01 Multi-Function Processor Interface Module (MPI) provides the INICT03 INFI-NET to Computer Transfer Module (ICT) with two serial ports and a SCSI parallel port. A 60-pin ribbon cable (supplied with MPI modules) connects the MPI module to the ICT module.

JUMPER SETTINGS

The MPI module has two sets of jumpers that select handshake signal types: request to send (RTS) or clear to send (CTS). These signals leave the module through a cable connection to the multi-function processor termination unit or the multi-function processor termination module. Figure 3-5 shows the jumper locations on the MPI module. Jumpers J1 and J2 must be set as shown in Figures 3-6 and 3-7.

Module placement within the module mounting unit is important when installing an ICT module with the MPI module. Installation requires two adjacent slots in a module mounting unit. The ICT module must occupy the right slot (when facing the front of the module mounting unit) and the MPI module must occupy the left slot.



Figure 3-5. IMMPIO1 Module Jumper Locations

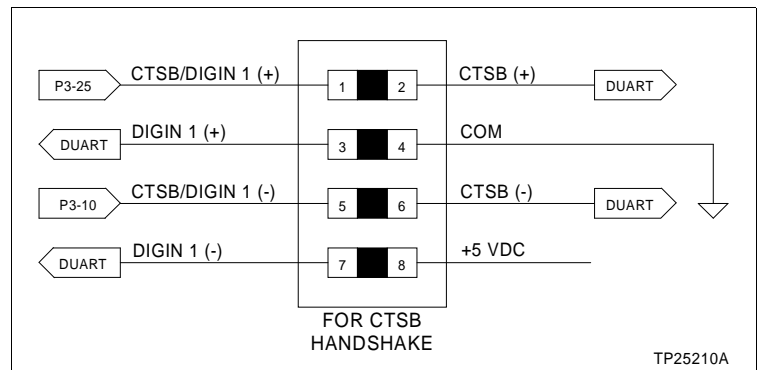

Figure 3-6. IMMPIO1 Module Jumper J1 Settings

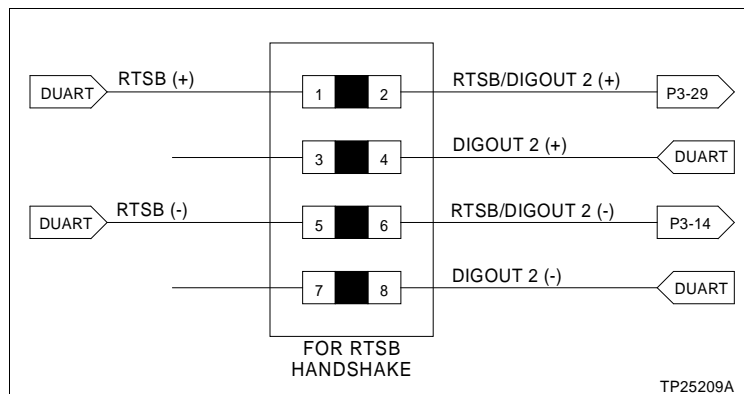

Figure 3-7. IMMPIO1 Module Jumper J2 Settings

INICT03 AND IMMPIO1 MODULE INSTALLATION

If the INICT03 and IMMPIO1 modules are properly configured, they are ready to be installed in the module mounting unit.

CAUTION	<p>To avoid potential module damage, evaluate your system for compatibility prior to module installation. This module uses connections to the module mounting unit backplane that served other functions in early Network 90 systems.</p>
ATTENTION	<p>Pour éviter d'endommager des modules, évaluez la compatibilité de votre système avant de les y brancher. L'usage que fait ce module de certaines connexions au fond de panier du châssis de montage diffère de l'assignation prévue par le système Network 90 original.</p>

To determine if the module mounting unit uses -30 VDC:

1. Locate the -30 VDC faston. It is the second faston from the top when viewing the module mounting unit from the rear.
2. Check for -30 VDC with respect to system common at the -30 VDC faston.
3. If -30 VDC is present, set the Jumper J5 of the ICT module to the appropriate positions.

To install the ICT and MPI modules:

1. Verify the ICT and MPI module slot assignments (ICT module in the right slot, MPI module in the left slot) in the module mounting unit are adjacent to its associated NIS module.
2. Connect one end of the 60-pin ribbon cable to connector P5 on the ICT module (see Figure 3-4).

3. Connect the other end of the cable to connector P6 on the MPI module (see Figure 3-5).

WARNING

Disconnect power before installing dipshunts on the module mounting unit backplane. Failure to do so will result in contact with cabinet areas that could cause severe or fatal shock.

AVERTISSEMENT

Interrompez l'alimentation avant d'installer des dipshunts sur le fond de panier du châssis de montage des modules. Sinon, tout contact avec cette zone entraîne des risques d'électrocution sérieuse ou fatale.

4. Verify that a 24-pin dipshunt is installed in the I/O expander bus sockets between the module mounting unit slot to be used by the NIS module and the slots to be used by the ICT and MPI modules.

NOTE: When installing the NIS, MPI and ICT modules, there must be continuity between the NIS and ICT modules. Observe the following:

- a. Install one dipshunt in the I/O expander bus socket between the NIS slot and ICT slot if the NIS module is mounted to the right of the MPI/ICT combination.
- b. If the NIS module is mounted to the left of the ICT module, two dipshunts are required. Install one dipshunt between the NIS slot and MPI slot. Install the second dipshunt between the MPI slot and the ICT slot.

5. Remove any 24-pin dipshunts from the I/O expander bus sockets that would connect the INICT03 or IMMPIO1 modules to any module other than those making up the INICIO3 computer interface.

6. Attach the hooded end of the NKTU01, NKTU02, NKTU11, or NKTU12 cable to the module mounting unit backplane cable connector opening for the ICT module. The other end of the cable attaches to the termination device or to the termination mounting unit backplane.

7. Slide the ICT and MPI modules in while guiding the top and bottom edges of the circuit boards along the top and bottom rails of the module mounting unit.

8. Push on the faceplate until the rear edges of the modules are firmly seated in the backplane connectors.

9. Turn the 2 latching screws of each faceplate ½ turn to lock the module in place. The modules are locked into place when the open end of the slot on the latching screws face the center of the faceplate.

SECTION 4 - OPERATING PROCEDURES

INTRODUCTION

After completing the configuration and installation steps detailed in [Section 3](#), the INFI-NET to computer interface modules are ready to be put into operation. This section provides the necessary information for daily operation of the INFI-NET to computer interface modules.

INNIS01 NETWORK INTERFACE SLAVE MODULE START-UP PROCEDURES

On power up, the INNIS01 Network Interface Slave Module (NIS) microprocessor stays in reset mode until its associated transfer module (INICT01 or INICT03) removes the reset mode and allows the firmware to execute self-diagnostic routines. The ICT module determines when the NIS module will go on-line. The NIS module comes on-line in the loop mode set by positions seven and eight of dipswitch SW3, with the counter display set by positions four through eight of dipswitch SW4.

Use the counter display (faceplate LEDs) to check the NIS module operation. If communication errors occur, the host module sets the NIS module communication status bits in the module status. View the module status using a monitoring device (console, computer, etc.) on the loop.

Event Counters

Internal counters maintain a count of events such as the number of messages transmitted, retries, and number of messages lost. [Table 3-5](#) has a complete list of event counters. The group A and B LEDs on the module faceplate display a binary value of the event counters (LED B-8 is the most significant bit, LED A-1 is the least significant bit). [Figure 4-1](#) shows the location of the group A and group B LEDs.

Error Counters

Errors such as receive errors, messages with circulation count errors, etc. are maintained in internal counters just like the event counters. Refer to [Table 3-6](#) for a listing of error counters. [Table 5-1](#) lists the error codes that appear on the NIS module faceplate LEDs.

INICT01 INFI-NET TO COMPUTER TRANSFER MODULE LEDs AND CONTROLS

The faceplate of the INICT01 module has the following components (see [Figure 4-2](#)):

- Status LED.

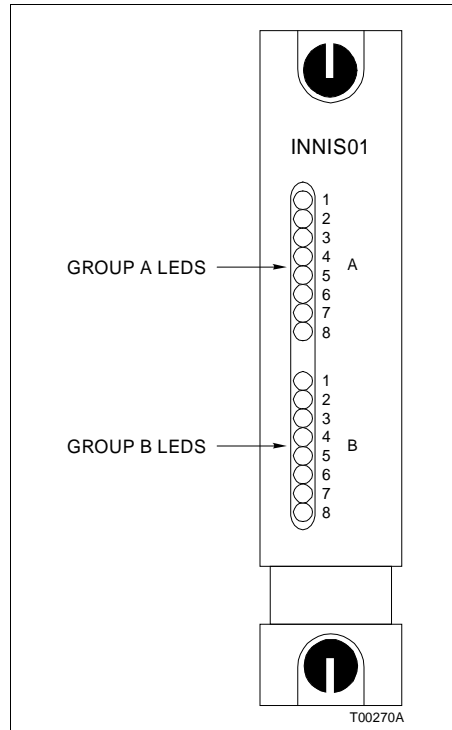

Figure 4-1. INNIS01
Module Faceplate LEDs

- Stop pushbutton.
- Two memory status LEDs.
- Eight CPU LEDs.
- Reset pushbutton.

Status LED

The status LED is a two color (red and green) LED that displays the operating status of the ICT module. It has three states. Table 4-1 lists the meaning of the status LED states. Refer to Section 5 for corrective action if the status LED indicates that an error exists.

CPU LEDs

During normal operation, the CPU LEDs keep a count of the commands and replies that pass through the ICT module. If an error occurs, these LEDs display an error code and the status LED turns red. Refer to Table 5-2 for a list of CPU LED error codes and associated corrective action.

Memory LEDs

There are two memory LEDs. The MEM LED 2 is on while the module is correcting single bit errors. Both LEDs are on when a two-bit error or a complete memory failure occurs.

SECTION 5 - TROUBLESHOOTING

INTRODUCTION

Troubleshooting the INICIO1 and INICIO3 INFI-NET to Computer Interfaces is limited to viewing the contents of the error counters and the module status report from any INFI 90 operator interface. Refer to the instruction for your specific computer interface for information on module status reports.

ERROR COUNTERS

All INFI-NET communication modules have faceplate LEDs that serve as error code displays. The NIS module has event and error counters that are selectable (refer to Tables 3-5 and 3-6).

INNIS01 MODULE ERROR CODES

The NIS module error counters count errors in the same manner as the event counters count events. Table 3-6 lists the error counters. The NIS module halts operation if a fatal error condition occurs. Group A LEDs display error codes. Group B LEDs are off when group A LEDs are displaying error codes. Refer to Table 5-1 for a list of error codes and associated corrective action.

Table 5-1. INNIS01 Module Error Codes

Code	LED	Condition	Corrective Action
	8 7 6 5 4 3 2 1		
13	0 0 0 1 0 0 1 1	ROM checksum error	Replace NIS module
16	0 0 0 1 0 1 1 0	Loopback test failure	Replace NIS module, check cabling and termination unit
31	0 0 1 1 0 0 0 1	Memory or CPU fault	Replace NIS module
32	0 0 1 1 0 0 1 0	Address or bus error	Reset ICT module, replace NIS module if error continues
33	0 0 1 1 0 0 1 1	Illegal instruction	
34	0 0 1 1 0 1 0 0	Trace/privilege violation	
35	0 0 1 1 0 1 0 1	Spurious/unassigned exception	
36	0 0 1 1 0 1 1 0	Divide by zero/checksum/format error	
37	0 0 1 1 0 1 1 1	Trap instruction	
38	0 0 1 1 1 0 0 0	Invalid dipswitch setting on NIS module	Check dipswitch SW1 through SW4
3E	0 0 1 1 1 1 1 0	NIS/device handshake failure	Verify that dipshunt exists between NIS and ICT modules. If dipshunt exists, replace NIS or ICT module.

NOTE: 0 = LED OFF, 1 = LED ON.

INICT01 AND INICT03 MODULE ERROR CODES

If errors occur while the ICT module is operating, the status LED turns red and the CPU LEDs on the ICT module faceplate display error codes. Table 5-2 lists the ICT module error codes and associated corrective action. The ICT module displays error codes only when it is halted. Five status bytes provide information about the ICT module status. Tables 5-3, 5-4, and 5-5 list the NIS module edge connector pin assignments. Tables 5-6, 5-7, and 5-8 list the INICT01 module edge connector pin assignments. Tables 5-9, 5-10, and 5-11 list the INICT03 module edge connector pin assignments. Tables 5-12 and 5-13 list the IMMPIO1 module edge connector pin assignments.

A code that is not on the list may appear if a machine fault time-out occurs. Reset the ICT module if this happens. The ICT module has failed if the status LED remains red. Replace the ICT module in this case.

Table 5-2. INICT01 and INICT03 Module Error Codes

Code	LED	Condition	Corrective Action
	8 7 6 5 4 3 2 1		
0D	0 0 0 0 1 1 0 1	I/O expander bus errors	Check I/O expander bus for connections to other modules.
12	0 0 0 1 0 0 1 0	NIS module not responding	Replace NIS module.
13	0 0 0 1 0 0 1 1	ROM checksum error	Replace NIS module
19	0 0 0 1 1 0 0 1	SCSI port error (INICT03 only)	Replace NIS module, check cabling and termination unit
31	0 0 1 1 0 0 0 1	Memory or CPU fault	Replace ICT module
32	0 0 1 1 0 0 1 0	Address or bus error	Reset ICT module, replace ICT module if error continues
33	0 0 1 1 0 0 1 1	Illegal instruction	
34	0 0 1 1 0 1 0 0	Trace/privilege violation	
35	0 0 1 1 0 1 0 1	Spurious/unassigned exception	
36	0 0 1 1 0 1 1 0	Divide by zero/checksum/format error	
39	0 0 1 1 1 0 0 1	Duplicate node number on loop	Change node number
3F	0 0 1 1 1 1 1 1	The ICT module has stopped because the user pressed the stop pushbutton	Reset ICT module

NOTE: 0 = LED OFF, 1 = LED ON.

1. Codes are displayed only when the ICT module is halted and the status LED is red.

*Table 5-3. INNIS01 Module Edge Connector
P1 Pin Assignments*

Pin	Signal	Pin	Signal
1	+5 VDC	2	+5 VDC
3	Unused	4	Unused
5	Common	6	Common
7	+15 VDC	8	-15 VDC
9	Power fail interrupt	10	Power fail interrupt
11	Unused	12	Unused

*Table 5-4. INNIS01 Module Edge Connector
P2 Pin Assignments*

Pin	Signal	Pin	Signal
1	Data bit 1	2	Data bit 0
3	Data bit 3	4	Data bit 2
5	Data bit 5	6	Data bit 4
7	Data bit 7	8	Data bit 6
9	Clock	10	Sync
11	Unused	12	Unused

*Table 5-5. INNIS01 Module Edge Connector
P3 Pin Assignments*

Pin	Signal	Pin	Signal
1	Receive 1 (-)	A	Receive 1 (+)
2	Ground	B	Ground
3	Ground	C	Ground
4	Bypass control (-)	D	Bypass control (+)
5	Ground	E	Ground
6	Transmit 1 (-) (phase 2)	F	Transmit 1 (+) (phase 2)
7	Transmit 1 (+) (phase 1)	H	Transmit 1 (-) (phase 1)
8	Ground	J	Ground
9	Transmit 2 (-) (phase 1)	K	Transmit 2 (+) (phase 1)
10	Transmit 2 (+) (phase 2)	L	Transmit 2 (-) (phase 2)
11	Ground	M	Ground
12	Power system status 2	N	Power system status 1
13	Ground	P	Ground
14	Ground	R	Ground
15	Receive 2 (+)	S	Receive 2 (-)

Table 5-6. INICT01 Module Edge Connector
P1 Pin Assignment

Pin	Signal	Pin	Signal
1	+5 VDC	2	+5 VDC
3	Unused	4	Controlway B
5	Common	6	Common
7	Unused	8	Unused
9	Power fail interrupt	10	Power fail interrupt
11	Controlway A/module bus	12	Unused

Table 5-7. INICT01 Module Edge Connector
P2 Pin Assignments

Pin	Signal	Pin	Signal
1	Data bit 1	2	Data bit 0
3	Data bit 3	4	Data bit 2
5	Data bit 5	6	Data bit 4
7	Data bit 7	8	Data bit 6
9	Clock	10	Sync
11	Unused	12	Unused

Table 5-8. INICT01 Module Edge Connector P3 Pin Assignments

Pin	Signal	Pin	Signal
1	SAC/DCS link (+)	A	SAC/DCS link (-)
2	Redundancy link transmit data (+)	B	Redundancy link transmit data (-)
3	Redundancy link receive data (-)	C	Redundancy link receive data (+)
4	Terminal port transmit data	D	Terminal port receive data
5	Terminal port request to send	E	Terminal port clear to send
6	Terminal port data carrier detect	F	Unused
7	Printer port transmit data	H	Printer port receive data
8	Printer port request to send	J	Printer port clear to send
9	Printer port data carrier detect	K	Unused
10	Digital output 1 (+)	L	Digital output 1 (-)
11	Digital output 2 (+)	M	Digital output 2 (-)
12	Unused	N	Unused
13	Unused	P	Unused
14	Unused	R	Unused
15	Unused	S	Unused

*Table 5-9. INICT03 Module Edge Connector
P1 Pin Assignment*

Pin	Signal	Pin	Signal
1	+5 VDC	2	+5 VDC
3	Power supply status	4	Controlway B
5	Common	6	Common
7	Unused	8	-15 VDC
9	Power fail interrupt	10	Power fail interrupt
11	Controlway A/module bus	12	Unused

*Table 5-10. INICT03 Module Edge Connector
P2 Pin Assignments*

Pin	Signal	Pin	Signal
1	Data bit 1	2	Data bit 0
3	Data bit 3	4	Data bit 2
5	Data bit 5	6	Data bit 4
7	Data bit 7	8	Data bit 6
9	Clock	10	Sync
11	Unused	12	Unused

*Table 5-11. INICT03 Module Edge Connector
P3 Pin Assignments*

Pin	Signal	Pin	Signal
1	Red1 parity	16	Ground
2	Red1 data 7	17	Red1 data 6
3	Red1 data 5	18	Red1 data 4
4	Red1 data 3	19	Red1 data 2
5	Red1 data 1	20	Red1 data 0
6	Ground	21	Ground
7	Red1 clock	22	Red2 clock
8	Ground	23	Ground
9	Red1 busy	24	Red2 busy
10	Ground	25	Ground
11	Red2 data 7	26	Red2 data 6
12	Red2 data 5	27	Red2 data 4
13	Red2 data 3	28	Red2 data 2
14	Red2 data 1	29	Red2 data 0
15	Ground	30	Red2 parity

Table 5-12. IMMPIO1 Module Edge Connector
P1 Pin Assignment

Pin	Signal	Pin	Signal
1	+5 VDC	2	+5 VDC
3	Unused	4	Unused
5	Common	6	Common
7	Unused	8	Unused
9	Unused	10	Unused
11	Unused	12	Unused

Table 5-13. IMMPIO1 Module Edge Connector
P3 Pin Assignments

Pin	Signal	Pin	Signal
1	SAC/DCS link A (-)	16	SAC/DCS link A (+)
2	SAC/DCS link B (-)	17	SAC/DCS link B (+)
3	Unused	18	Unused
4	Unused	19	Unused
5	Unused	20	Unused
6	Unused	21	Unused
7	Receive data A (-)	22	Receive data A (+)
8	Receive data B (-)	23	Receive data B (+)
9	Clear to send A (-)	24	Clear to send A (+)
10	Clear to send B (-)	25	Clear to send B (+)
11	Transmit data A (-)	26	Transmit data A (+)
12	Transmit data B (-)	27	Transmit data B (+)
13	Request to send A (-)	28	Request to send A (+)
14	Request to send B (-)	29	Request to send B (+)
15	Digital output 1 (+)	30	Digital output 1 (-)

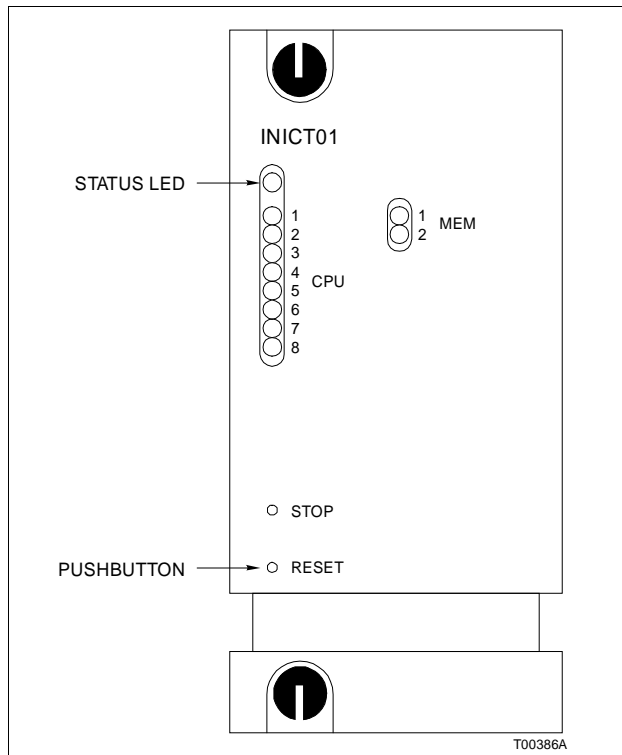

Figure 4-2. INICT01 Module Faceplate LEDs and Controls

Table 4-1. INICT01 Module Status LED States

LED State	Description
Off	No power to the ICT module.
Solid Green	The ICT module is in execute mode.
Solid Red	The ICT module diagnostics detect a hardware failure or configuration problem. CPU LEDs display an error code when the status LED is red.

Stop Switch

Push the stop switch and wait for the status LED to turn red before removing a ICT module from the module mounting unit. Using the stop switch allows any NVRAM write operation in progress to complete before the module halts operation.

Reset Switch

Pressing the reset switch causes the restoration of the ICT module to the power up values after a halt. It is also used to recover from an operator-initiated stop or a module time-out.

INICT03 INFI-NET TO COMPUTER TRANSFER MODULE LEDS AND CONTROLS

The faceplate of the INICT03 module has the following components (see Figure 4-3):

- Status LED.
- 16 CPU LEDs.
- Stop/reset pushbutton.

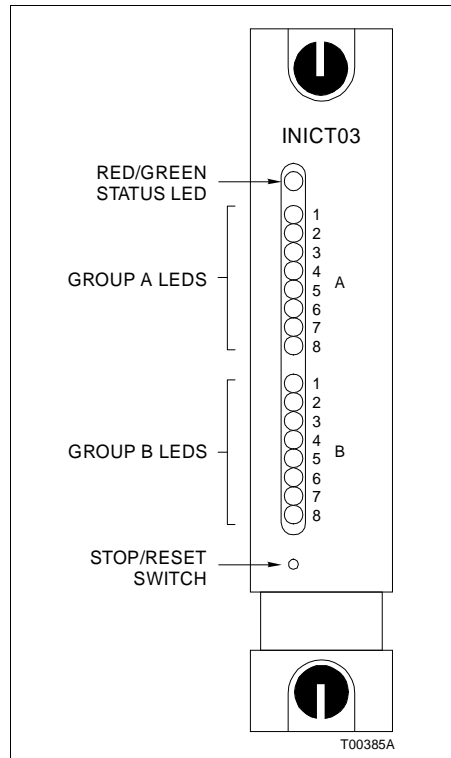

Figure 4-3. INICT03 Module Faceplate LEDS and Controls

Status LED

The status LED is a two color (red and green) LED that displays the operating status of the ICT module. It has three possible states. Table 4-2 lists the meaning of the status LED states. Refer to Section 5 for corrective action if the status LED indicates that an error exists.

Table 4-2. INICT03 Module Status LED States

LED State	Description
Off	No power to the ICT module.
Solid Green	The ICT module is in execute mode.
Solid Red	The ICT module diagnostics detect a hardware failure or configuration problem. CPU LEDs display an error code when the status LED is red.

CPU LEDs

There are two groups of eight CPU LEDs. Group A LEDs display a moving pattern to indicate the module is functioning. Group B LEDs, during normal operation, keep count of the commands and replies that pass through the INICT03 module. If an error occurs, these LEDs display an error code and the status LED turns red. Refer to Table 5-2 for a list of CPU LED error codes and associated corrective action.

Stop/Reset Pushbutton

Push the stop/reset pushbutton once and wait for the status LED to turn red before removing an ICT module from the module mounting unit. Pressing the stop/reset pushbutton twice causes the restoration of the ICT module to power up values after a halt. It is also used to recover from an operator initiated stop or a module time-out.

INICI01 AND INICI03 MODES OF OPERATION

The INICI01 and INICI03 INFI-NET to Computer Interfaces have two modes of operation: execute and error.

Execute Mode

This mode applies to the INICT01 and INICT03 modules and is the normal mode of operation for the ICI computer interface. In the execute mode, the host computer and INFI-NET system interact through the ICI computer interface. ICI computer interface firmware permits the configuration of computer interface and control modules through the host computer. Refer to the **Function Code Applications Manual** for more information. The ICT module (while in execute mode) can collect exception reports, exercise control, allow the operator to adjust tunable module specifications, configure modules within a node residing on the INFI-NET system and do routine system security functions.

Error Mode

The INICT01 and INICT03 modules enter this mode if the built-in system diagnostic routines detect a hardware or execution error. If the ICT module detects an error, the module halts and displays an error code on the CPU LEDs. Refer to **Section 5** for corrective action when the ICT module enters the error mode.

SECURITY FUNCTIONS

The INICT01 and INICT03 modules perform both hardware and software security checks to insure module integrity.

Hardware Checks

The INICT01 and INICT03 modules do the following hardware checks:

Error Detection and Correction	(INICT01 module only) Detects single bit and double bit errors in the dynamic RAM memory. Corrects single bit errors but halts ICT module operation on double bit errors.
Illegal Address Detection	Detecting an illegal address generates a bus error and the ICT module halts operation.
Machine Fault Timer	The microprocessor updates this timer. A machine fault time-out halts ICT module operation.

Software Checks

The INICT01 and INICT03 modules do the following software checks:

Module Diagnostics	The ICT module diagnostic routines execute automatically on system power up. If the diagnostic tests fail, the faceplate LEDs display error conditions, the status LED goes red, and the module operation halts.
ROM Checksum Check	This test verifies checksums of the ROM memory. Discrepancies cause the ICT module status LED to go solid red and the ICT module operation halts.

UTILITIES

The utilities menu shown in Figures 4-4 (INICT01 module) and 4-5 (INICT03 module) is available by attaching a diagnostic monitor to port two of the ICT module termination device. Enable this option through the ICT module dipswitches. Description of the utilities menu options follow:

TALK90 Option

Selecting this option displays a menu of all the commands available to the computer interface. Figure 4-6 shows an example *TALK90 COMMAND MENU*.

The ICT module must be on-line to use most of these commands. Use the RESTART command to put the ICT module on-line. To execute the RESTART command, select command 19 from the *TALK90 COMMAND MENU*. Enter the following values when prompted:

Key? 0

Watchdog? 0

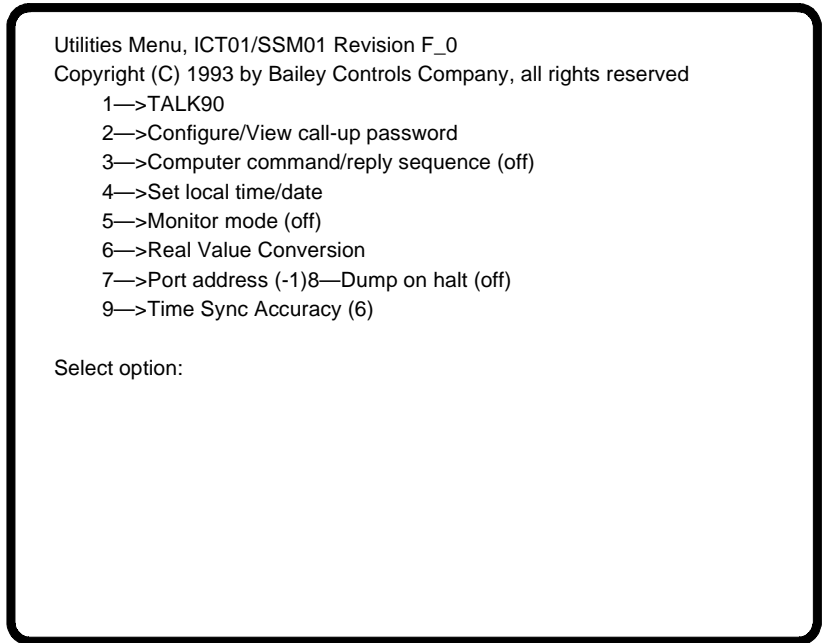

Figure 4-4. Example INICT03 Module Utilities Menu

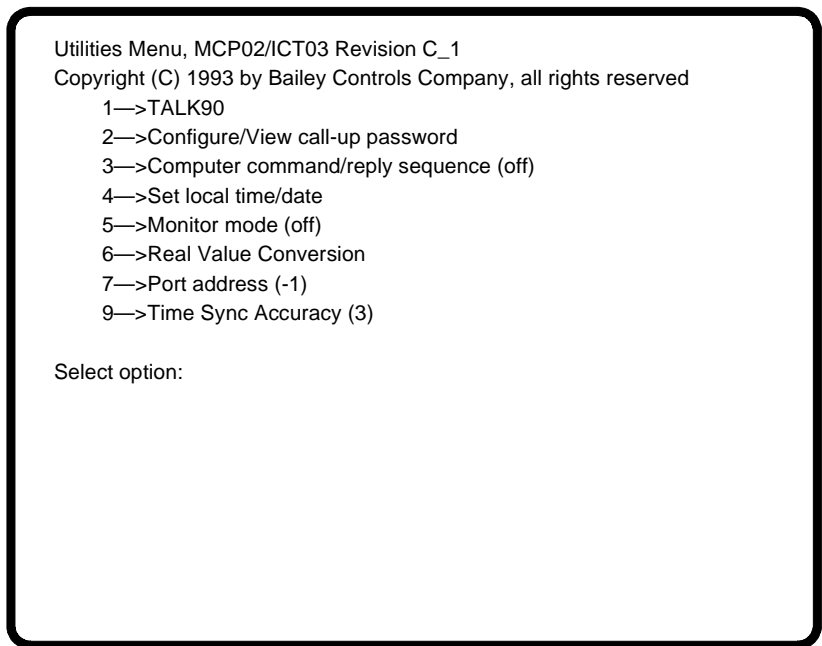

Figure 4-5. Example INICT01 Module Utilities Menu

TALK90 COMMAND MENU			
1 Establish Point	2 Establish Report	3 Output Misc	4 Connect Pnt List
5 Discnct Pnt List	6 Read Value List	7 Read Status List	8 Read Exceptions
10 Output Value	11 Output Status	12 Module Operation	13 Read Block
14 Read Next Block	15 Read Default Blk	16 Write Block	17 Tune Block
18 Delete Block	19 Restart	20 Read Blk Output	21 Rd Misc Stat Lst
22 Rd Misc Stat XR	23 Disestablish Pnt	24 Read Specs	25 Dequeue
26 Read Problem Rpt	27 Demand Mod Stat	28 Regenerate Specs	33 Set Status
34 Read Work Flag	35 Read Value Group	36 Discnct Pnt Grp	37 Connect Pnt Grp
38 Read Stat Grp	39 Rd Misc Stat Grp	40 Output Value Grp	41 Callup
42 Hangup	43 Read Sys Time	44 On/Offline	45 Output Misc Grp
46 Rd Ext Prob Rpt	47 Output Stat Value	48 Trend Data Poll	49 Est & Connect
50 Cancel Keyed Cmd	52 Rd Station Specs	53 Rd Station XR	54 Read Station Lst
55 Read Station Grp	56 Output Stn Value	57 Output Stn Group	58 Read Command XR
59 Output Stn Reprt	60 Set Sys Time	61 Define Nodes	62 Quick XR
63 Read Data XR	64 Read Data List	65 Read Data Group	66 Read Data Specs
67 Output Report	69 Environment	70 Data Formats	71 Set Clock
72 Read Clock	73 Set Time	74 Read Time	75 Read Trend XR's
76 Enh Trend Poll	77 Disestab Trend	78 Comm Diagnostics	97 Repeat Command
98 Build Command	99 Exit		

Select Command:

Figure 4-6. Example TALK90 Command Menu

Restart Options:

128 = enhanced mode

64 = separate command exceptions from XR's

32 = time-sync enabled

16 = XR screening

8 = return work-flag in replies

4 = XON/XOFF protocol

2 = primary mode

1 = stations can be put into computer mode

Sum? 130

Reply Delay? 0

Additional Options:

4 = Bad Quality Alarm Management

2 = add Wall Clock Offset to Time Stamp

1 = return Time Stamp

Sum? 0

If the computer interface is functioning properly, the utilities menu will appear again. Select TALK90 to continue. The computer interface should return a reply code of 0 followed by the node and loop address as follows:

Response → 0

No Error

Node Number: 2

Loop Number: 1

<RET> to continue

The CPU LEDs on the ICT module will display the count of commands and replies that were sent and received. The NIS module should then go on-line and the computer interface will be able to communicate to INFI-NET nodes. The utilities menu will appear again. Select TALK90 to continue.

Use any of the available commands on the TALK90 menu to check the system.

Configure/View Callup Password Option

Selecting this option allows the password to be viewed and/or changed. The following information is displayed by this option:

Current Password: 1 2 3 4 5 6 7 8

Define new password (Y/N)?

Answering **Y** to the prompt causes the following information to be displayed. A sample password is shown being entered:

Input 8 hexadecimal password bytes, example:

? **BB CC DD EE FF 11 22 33**

? 11 22 33 44 55 66 77 88

New password written!

Answering **N** to the prompt causes the terminal to return to the utilities menu (see Figure 4-4 or 4-5).

NOTE: This option defines the password for the ICT ports. To use this feature, the password protection option (position 5, dipswitch U72) on the ICT module must be enabled.

Computer Command/Reply Sequences Option

This option, when enabled, causes the computer interface to echo computer commands and replies in hexadecimal format on the terminal. Commands on the serial port are preceded by a CS; replies on the serial port are preceded by an RS. Commands on the parallel port are preceded by a CP, and replies on the parallel port are preceded by a RP. Pressing **3** toggles this feature on and off. Figure 4-7 shows an example of a RESTART command followed by a DEMAND MODULE STATUS command.

NOTE: This option slows computer interface response time and should be disabled when not in use.

Set Local Time and Date Option

Selecting this option causes the following information to be displayed:

0:0:0 Saturday 3/1/1980 Change (Y/N)?

```
CD 13 00 00 0A 00 00 1D 0D
RS 00 05 00 05 0D

CS 1B 1B 00 00 32 00 00 4D 0D
RS 00 E1 00 80 00 61 0D
```

*Figure 4-7. RESTART and DEMAND MODULE STATUS
Commands and Replies*

Answering **Y** to the prompt causes the *TIME Utilities* menu to be displayed. See Figure 4-8 for an example time utilities menu. Select the desired function and follow the screen prompts to complete the task. Answering **N** to the prompt causes the terminal to return to the utilities menu.

Monitor Mode Option

Selecting this option enables or disables the monitor mode. When enabled, all control commands from the terminal or the host computer are ignored by the computer interface. The terminal or host computer can monitor data only.

Real Value Conversion Option

This option does real value conversions on the terminal screen. Selecting this option causes the following information to be displayed:

Value or REAL 2/3/4/8 conversion (V or R)?

Pressing **V** enables the decimal to real number converter feature and causes the following prompt to appear:

Enter value:

Entering a sample value of 1.0 causes the following information to be displayed:

Enter value: 1.0

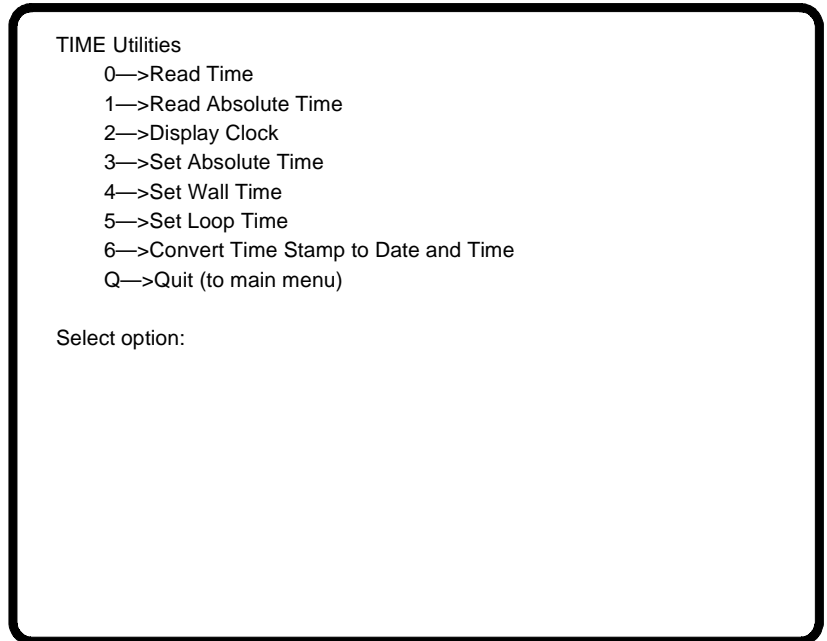

Figure 4-8. Example Time Utilities Menu

REAL2 = D2 00
 REAL3 = 02 80 00
 REAL4 = 3F 80 00 00
 REAL8 = 3F F0 00 00 00 00 00 00

Enter value:

Press **ENTER** to continue or exit. The original prompt appears:

Value or REAL 2/3/4/8 conversion (V or R)?

Pressing **R** enables the real to decimal number conversion feature and causes the following prompt to appear:

Enter REAL 2/3/4/8:

Entering a sample value of 3F 00 00 00 causes the following information to be displayed:

Enter REAL 2/3/4/8: **3F 00 00 00**

0.500000

Enter REAL 2/3/4/8:

Press **ENTER** to continue or exit.

Port Address Option

Selecting this option allows the port address to be changed. The following information will be displayed:

*Port Address is currently 0
Change Port Address (Y/N)?*

Answering **Y** to the prompt causes the following prompt to appear:

Enter new Port Address (0 to 31):

The new port address appears in line 7 of the utilities menu. The utilities menu automatically returns after executing this option.

Dump On Halt Option

Selecting this option (INICT01 modules only) toggles the dump on halt feature. If dump on halt is enabled, the ICT module will dump pertinent system data to the ICT module NVRAM upon a fatal error (the ICT module status LED will be red). This data can be used by qualified Bailey Controls Company personnel to determine the cause of a module failure.

Time Sync Accuracy Option

Selecting this option displays the current time synchronization accuracy and prompts the operator to enter a new rating. The rating indicates the accuracy (lack of drift) of the host clock device where:

- 0 = No clock (lowest accuracy rating)
- 3 = Default
- 6 = Low accuracy battery-backed clock
- 9 = High accuracy battery-backed clock
- 12 = Satellite clock (highest accuracy rating)

SECTION 6 - MAINTENANCE

INTRODUCTION

WARNING	Wear eye protection whenever working with cleaning solvents. When removing solvents from printed circuit boards using compressed air, injury to the eyes could result from splashing solvent as it is blown off the printed circuit board.
AVERTISSEMENT	Portez toujours de lunettes de protection lorsque vous utilisez des solvants de nettoyage. L'air comprimé servant à enlever le solvant des cartes de circuits imprimés provoque des éclaboussures qui risquent d'atteindre les yeux.

The reliability of any stand-alone product or control system is affected by the maintenance of the equipment. Bailey Controls recommends that all equipment users practice a preventive maintenance program that will keep the equipment operating at an optimum level.

This section presents procedures that the customer should be able to perform on site. These preventive maintenance procedures should be used as a guideline to assist you in establishing good preventive maintenance practices. Select the minimum steps required to meet the cleaning needs of your system.

Personnel performing preventive maintenance should meet the following qualifications:

- Maintenance personnel should be qualified electrical technicians or engineers that know the proper use of test equipment.
- Maintenance personnel should be familiar with the modules that make up the INICIO1 and INICIO3 INFI-NET to Computer Interfaces, have experience working with process control systems, and know what precautions to take when working on live AC systems.

PREVENTIVE MAINTENANCE SCHEDULE

Table 6-1 is the preventive maintenance schedule for the modules that make up the INICIO1 and INICIO3 INFI-NET to Computer Interfaces. The table lists the preventive maintenance tasks in groups according to their specified maintenance interval. Some tasks in Table 6-1 are self explanatory. Instruction

for tasks that require further explanation are covered under **PREVENTIVE MAINTENANCE PROCEDURES**.

NOTE: The preventive maintenance schedule is for general purposes only. Your application may require special attention.

Table 6-1. Preventive Maintenance Schedule

Task	Frequency
Check cabinet air filters. Clean or replace them as necessary. Check the air filter more frequently in excessively dirty environments.	3 months
Check cabinet and computer interface module for dust. Clean as necessary using an anti-static vacuum.	
Check all computer interface signal, power and ground connections within the cabinet. Verify that they are secure. See procedure.	
Check computer interface circuit boards, giving special attention to power contacts and edge connectors. Clean as necessary. See procedure.	12 months
Complete all tasks in this table.	Shutdown

EQUIPMENT/TOOLS REQUIRED

Listed below are the tools and equipment required for maintenance procedures.

- Antistatic vacuum.
- Clean, lint free cloth.
- Compressed air.
- Eberhard Faber (400A) pink pearl eraser.
- Fiberglass or nylon burnishing brush.
- Foam tipped swab.
- Flat screwdriver suitable for terminal blocks.
- Isopropyl alcohol (99.5 % electronic grade).
- Natural bristle brush.

PREVENTIVE MAINTENANCE PROCEDURES

This section covers tasks from Table 6-1 (preventive maintenance schedule) that require specific instruction or further explanation. The tasks and instruction covered are:

- Printed circuit board cleaning.
- How to check signal, power, and ground connections.

Printed Circuit Board Cleaning

There are several circuit board cleaning procedures in this section. These procedures cover circuit board cleaning and washing, cleaning edge connectors and circuit board laminate between edge connectors. Use the procedures that meet the needs of each circuit board. Remove all dust, dirt, oil, corrosion or any other contaminant from the circuit board.

Do all cleaning and handling of the printed circuit boards at static safe work stations. Always observe the steps under **SPECIAL HANDLING** in Section 3 of this instruction when handling printed circuit boards.

GENERAL CLEANING AND WASHING

If the printed circuit board needs minor cleaning:

Remove dust and residue from the printed circuit board surface using clean, dry, filtered compressed air or an antistatic field service vacuum cleaner.

Another method of washing the printed circuit board is:

1. Clean the printed circuit board by spraying it with isopropyl alcohol (99.5% electronic grade) or wiping the board with a foam tipped swab wetted in isopropyl alcohol.
2. When the circuit board is clean, remove excess solvent by using compressed air to blow it free of the circuit board.

EDGE CONNECTOR CLEANING

To clean edge connector contacts:

1. Use a solvent mixture of 80% isopropyl alcohol (99.5% electronic grade) and 20% distilled water.
2. Soak a lint free cloth with the solvent mixture.
3. Work the cloth back and forth parallel to the edge connector contacts.
4. Repeat with a clean cloth that is soaked with the solvent mixture.
5. Dry the edge connector contact area by wiping with a clean lint-free cloth.

To clean tarnished or deeply stained edge connector contacts:

1. Use an Eberhard Faber (400A) pink pearl eraser, or equivalent to remove tarnish or stains. Fiberglass or nylon burnishing brushes may be used also.
2. Minimize electrostatic discharge by using the 80/20 isopropyl alcohol and water solution during burnishing.
3. Do not use excessive force while burnishing. Use only enough force to shine the contact surface. Inspect the edge connector after cleaning to assure no loss of contact surface.

Checking Connections

Check all signal wiring, power and ground connections within the cabinet to verify their integrity. When checking connections, always turn a screw, nut or other fastening device in the direction to tighten only. If the connection is loose, it will be tightened. If the connection is tight, the tightening action will verify that it is secure. There must not be any motion done to loosen the connection.

NOTE: Power to the cabinet must be off while performing this preventive maintenance task.

Check and verify that all cable connections are secure.

SECTION 7 - REPAIR/REPLACEMENT PROCEDURES

INTRODUCTION

Repair procedures are limited to module replacement. If an INFI-NET to computer interface module fails, remove and replace it with another. Verify that the replacement module dipswitch and jumper settings are the same as those of the failed module.

NOTE: Do not remove INICT01 and INICT03 modules under power unless the stop (INICT01) or stop/reset (INICT03) pushbutton has been depressed and module operation has been halted.

MODULE REPLACEMENT PROCEDURE

Follow Steps 1 through 7 to replace computer interface modules. Observe the steps listed in the **SPECIAL HANDLING** portion of this manual when handling computer interface modules.

1. Turn the 2 latching screws on the defective computer interface module $\frac{1}{2}$ turn either way to release them. In the case of the INICT03 INFI-NET to Computer Interface, the INICT03 and IMMPIO1 or IMMPIO2 modules are connected by cable and must be disconnected.
2. Grasp the screws and slide out the module or modules.
3. If necessary, disconnect the cable connecting the modules and remove only the defective module.
4. Set any dipswitches and jumpers on the replacement module to match the settings of the removed module.
5. If necessary, connect the replacement module with any interconnecting modules.
6. Hold the module or modules by the faceplate and slide them into their assigned slots; push until the rear edges of the modules are firmly seated in the backplane connectors.
7. Turn the 2 latching screws on the module or modules $\frac{1}{2}$ turn to lock the modules in place. Modules are locked into the module mounting unit when the open end of the slots on the latching screws face the center of the module faceplate.

TERMINATION UNIT OR MODULE REPLACEMENT PROCEDURES

To replace the following termination devices, refer to the appropriate instructions for step by step replacement procedures and spare parts information:

- NTCL01 Communication Termination Unit.
- NICL01 Communication Termination Module.
- NTMF01 Multi-Function Controller Termination Unit.
- NIMF01 and NIMF02 Multi-Function Controller Termination Modules.
- NTMP01 Multi-Function Processor Termination Unit.
- NIMP01 and NIMP02 Multi-Function Processor Termination Modules.

SECTION 8 - SUPPORT SERVICES

INTRODUCTION

Bailey Controls is ready to help in the use and repair of its products. Contact the nearest sales office to make requests for sales, applications, installation, repair, overhaul and maintenance contract services.

REPLACEMENT PARTS AND ORDERING INFORMATION

When making repairs, order replacement parts from a Bailey Controls sales office. Provide this information:

1. Part description, part number and quantity.
2. Model and serial numbers (if applicable).
3. Bailey Controls instruction manual number, page number and reference figure that identifies the part.

Order parts without commercial descriptions from the nearest Bailey Controls sales office.

Table 8-1. Spare Parts List

Description	Part Number
Jumper	1946984_1

NOTE: It is impractical to specify a recommended quantity of spare parts because Bailey custom designs every system. Contact Bailey Controls Company if you need help determining the quantity of spare parts you should keep on hand for your particular system.

TRAINING

Bailey Controls has a modern training facility available for training your personnel. On-site training is also available. Contact a Bailey Controls sales office for specific information and scheduling.

TECHNICAL DOCUMENTATION

Additional copies of this manual or other Bailey Controls manuals, can be obtained from the nearest Bailey Controls sales office at a reasonable charge.

APPENDIX A - NTCL01 TERMINATION UNIT CONFIGURATION

INTRODUCTION

The INNIS01 Network Interface Slave Module (NIS) can use the NTCL01 Communication Termination Unit (TCL) for termination. Jumpers on the TCL unit select the type of cable used to connect the NIS module to an INFI-NET system. Refer to the NTCL01 instruction for complete information. Figure A-1 shows the location of jumpers and connectors. Figures A-2 and A-3 show the coaxial and twinaxial cable connections. Table A-1 lists the jumper settings used on TCL unit circuit board revision levels D and E. Table A-2 lists the jumper settings used on TCL unit circuit board revision levels F or higher.

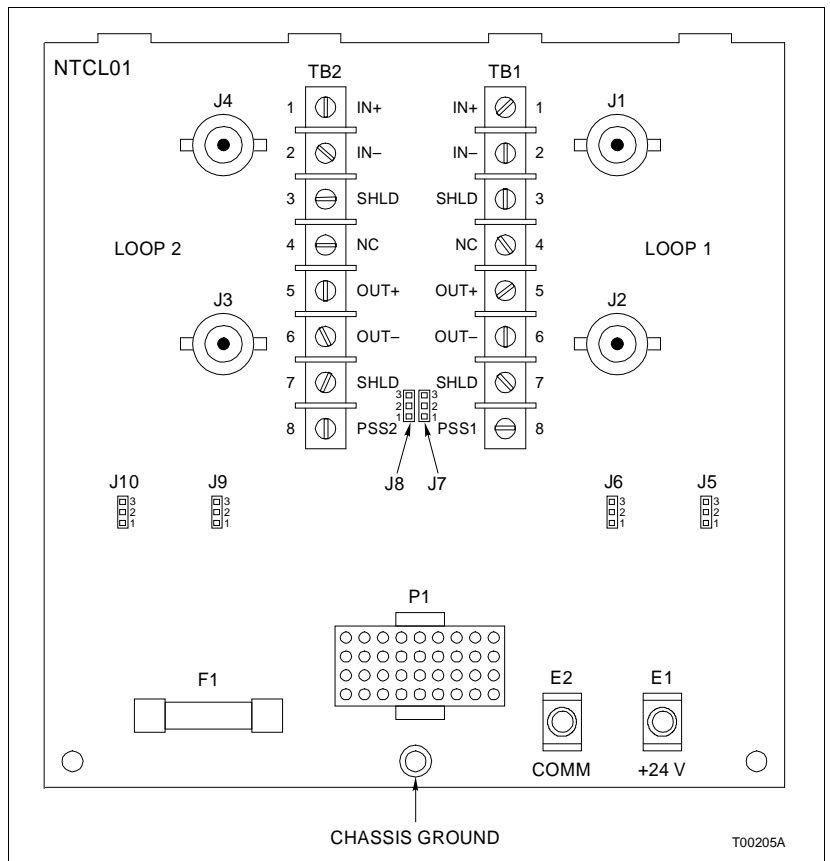

Figure A-1. NTCL01 Connector and Jumper Locations (Revision F or Greater)

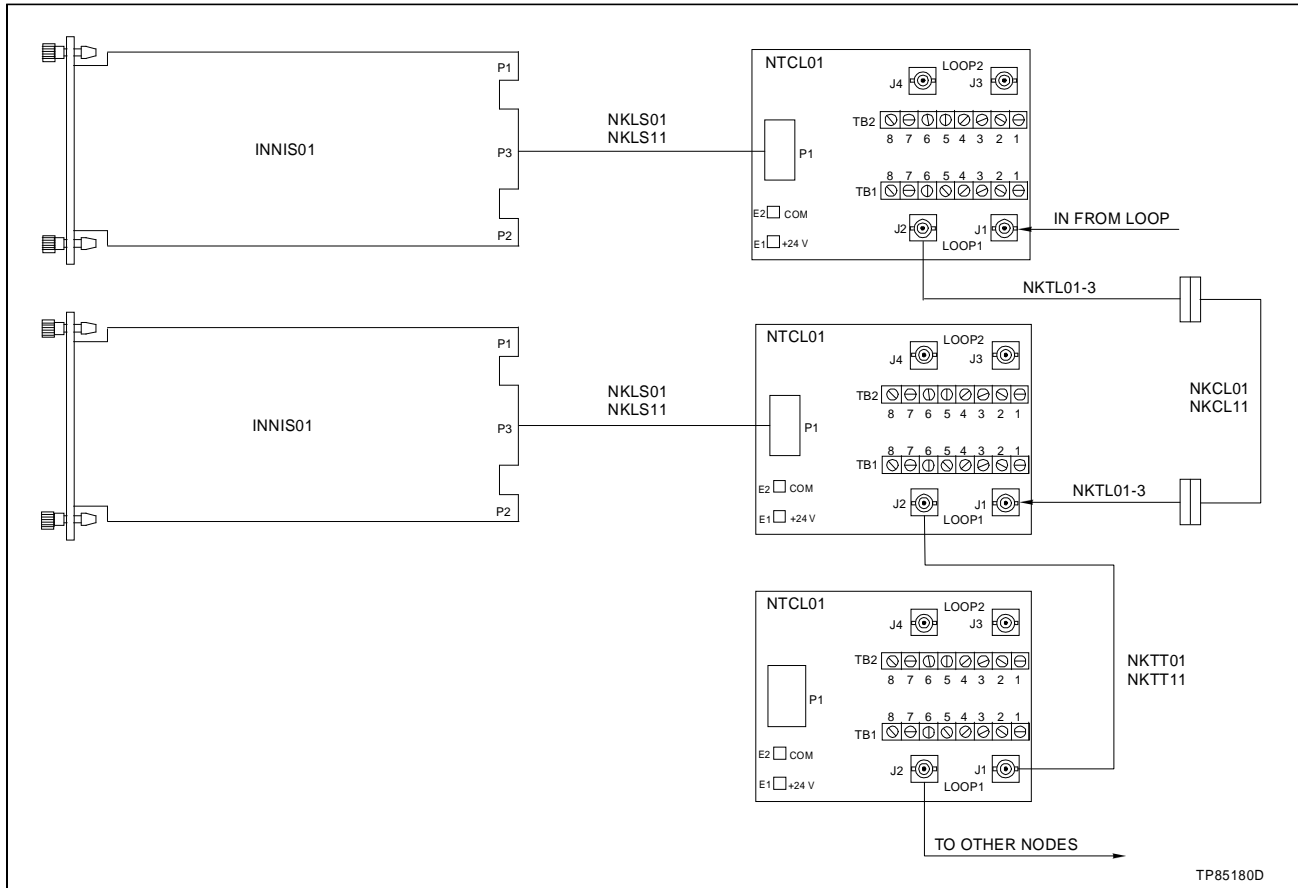

Figure A-2. NTCL01 Coaxial Cable Connections to INNIS01 Modules

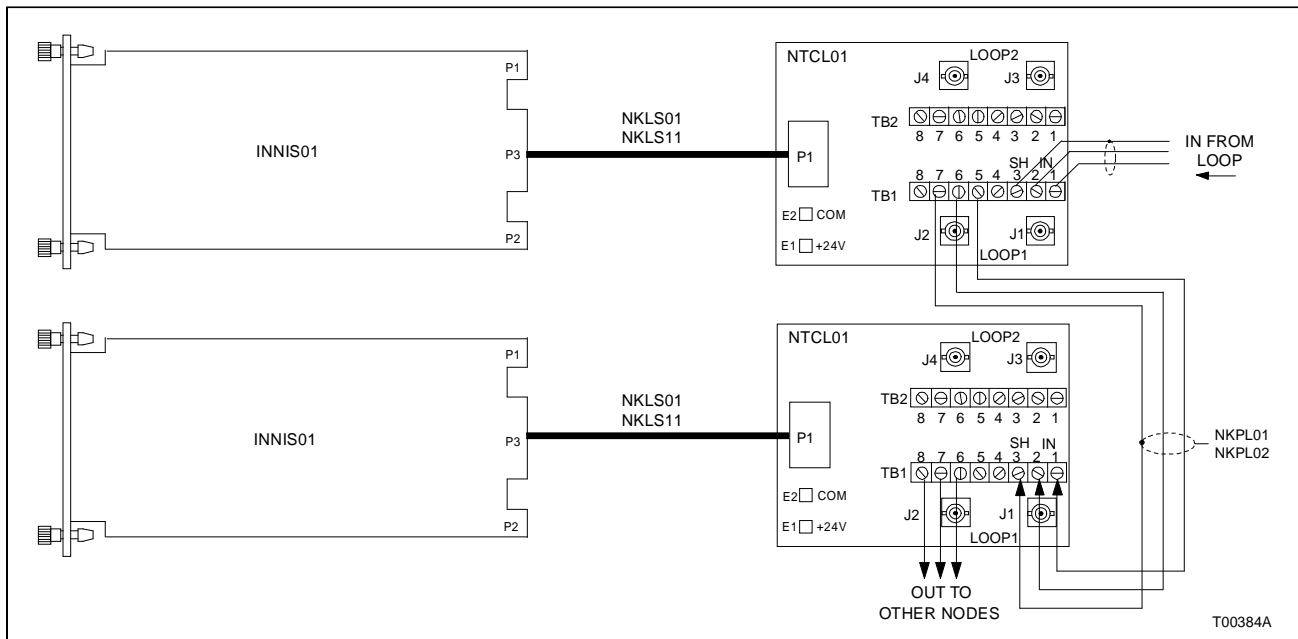

Figure A-3. NTCL01 Twinaxial Cable Connections to INNIS01 Modules

Table A-1. NTCL01 Jumper Settings for Revision D and E

Jumper Number	Twinaxial Cable Jumper Settings	Coaxial Cable Jumper Settings
J5 - J12	2 - 3	2 - 3
J13 - J18	1 - 2	2 - 3

Table A-2. NTCL01 Jumper Settings for Revision F or Greater

Jumper Number	Twinaxial Cable Jumper Settings	Coaxial Cable Jumper Settings
J5 - J10	1 - 2	2 - 3

APPENDIX B - NICL01 TERMINATION MODULE CONFIGURATION

INTRODUCTION

The INNIS01 Network Interface Slave Module (NIS) can use the NICL01 Communication Termination Module (ICL) for termination. Jumpers on the ICL module select the type of cable used to connect the NIS module to an INFI-NET system. Refer to the NICL01 instruction for complete information. Figure B-1 shows the location of jumpers and connectors. Figures B-2 and B-3 show the coaxial and twinaxial cable connections. Table B-1 lists the jumper settings used on ICL module circuit board revision level C. Table B-2 lists the jumper settings used on ICL module circuit board revision levels D or higher.

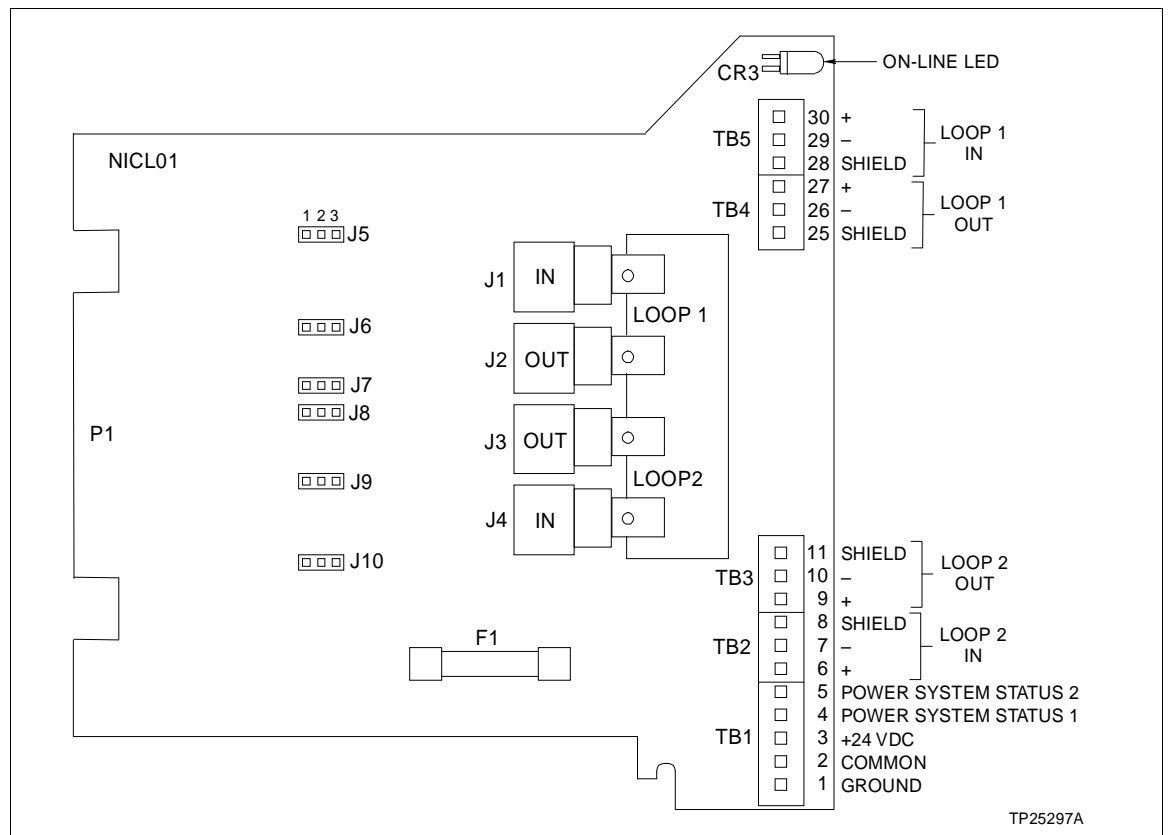

Figure B-1. NICL01 Connector and Jumper Locations (Revision D or Greater)

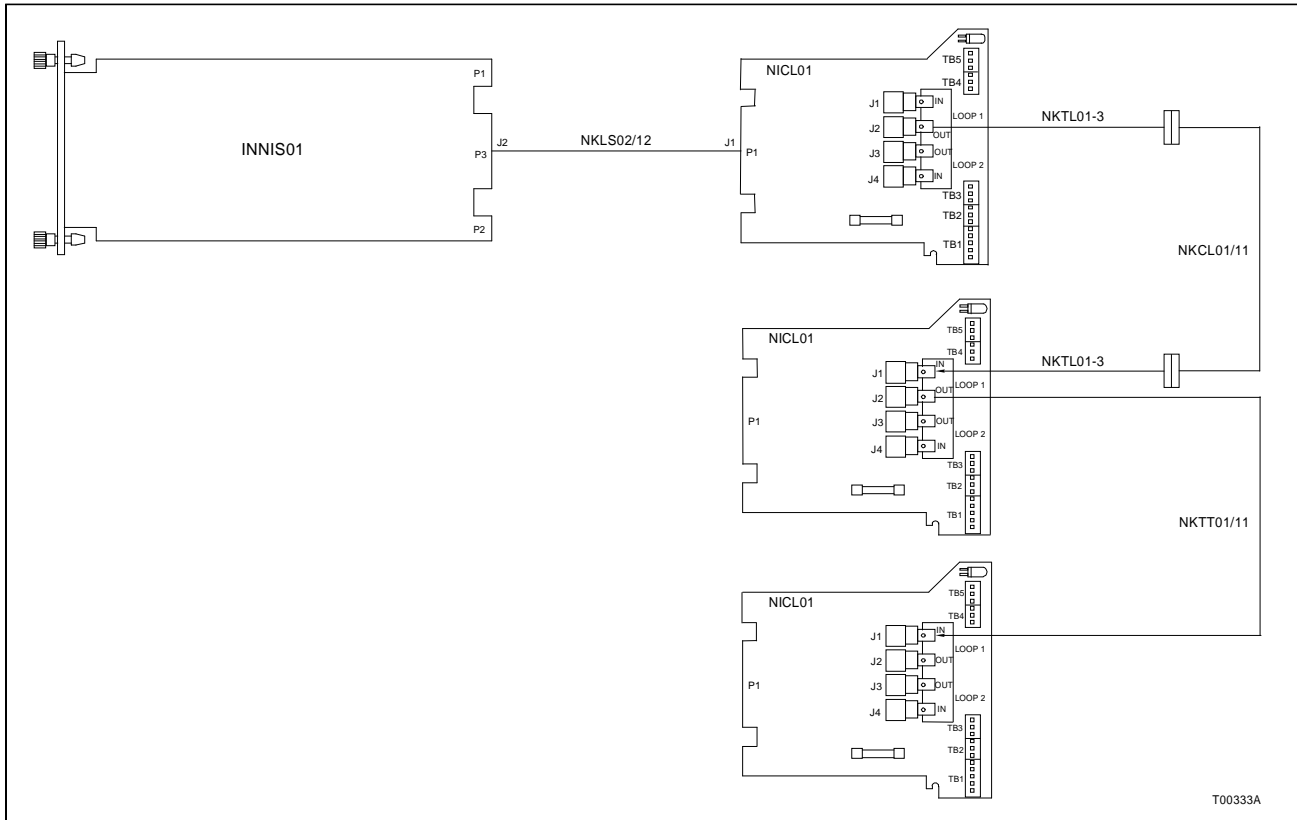

Figure B-2. NICL01 Coaxial Cable Connections to INNIS01 Modules

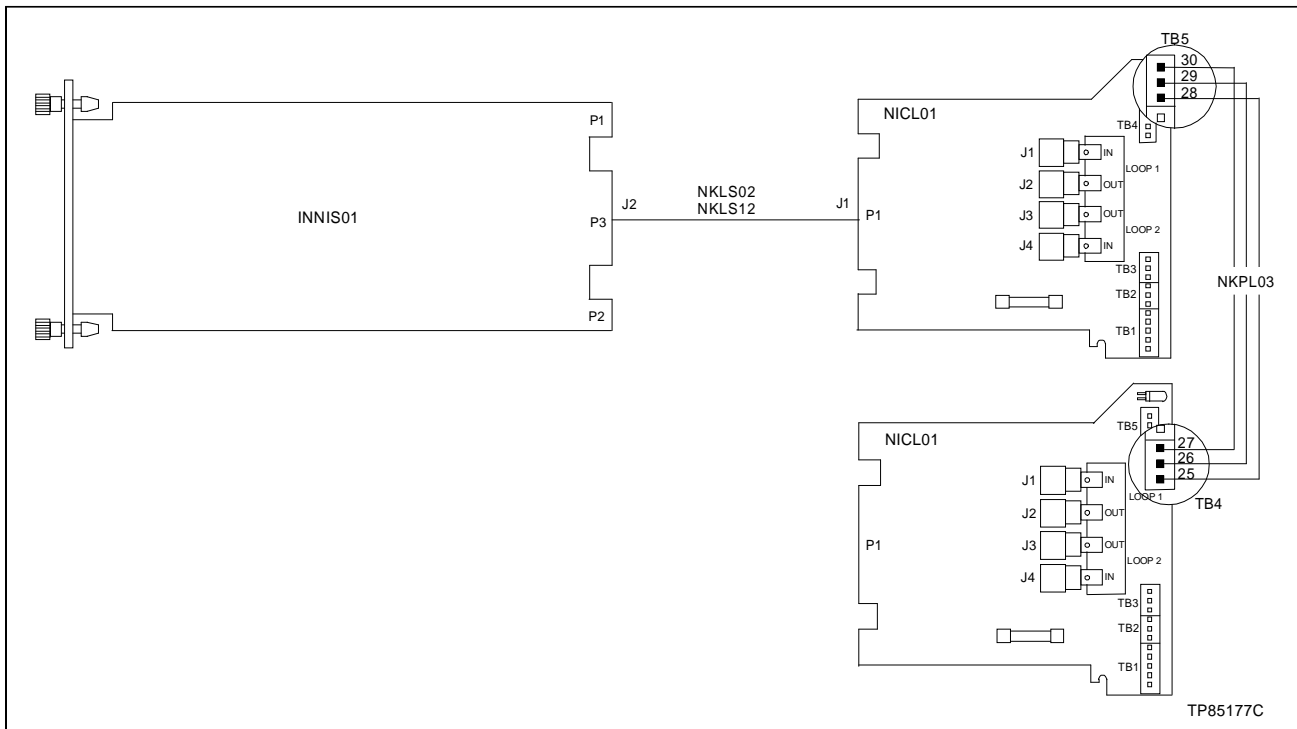

Figure B-3. NICL01 Twinaxial Cable Connections to INNIS01 Modules

Table B-1. NICL01 Jumper Settings for Revision C

Jumper Number	Twinaxial Cable Jumper Settings	Coaxial Cable Jumper Settings
J5 - J12	2 - 3	2 - 3
J13 - J18	1 - 2	2 - 3

Table B-2. NICL01 Jumper Settings for Revision D or Greater

Jumper Number	Twinaxial Cable Jumper Settings	Coaxial Cable Jumper Settings
J5 - J10	1 - 2	2 - 3

APPENDIX D - NIMF01/NIMF02 TERMINATION MODULE CONFIGURATION

INTRODUCTION

The INICT01 INFI-NET to Computer Transfer Module (ICT) uses the NIMF01 Multi-Function Controller Termination Module for termination. The NIMF02 Multi-Function Controller Termination Module is required when terminating redundant interfaces. The dipshunt configurations shown in Figures D-1, D-2, D-3, and D-4 apply to both NIMF01 and NIMF02 modules.

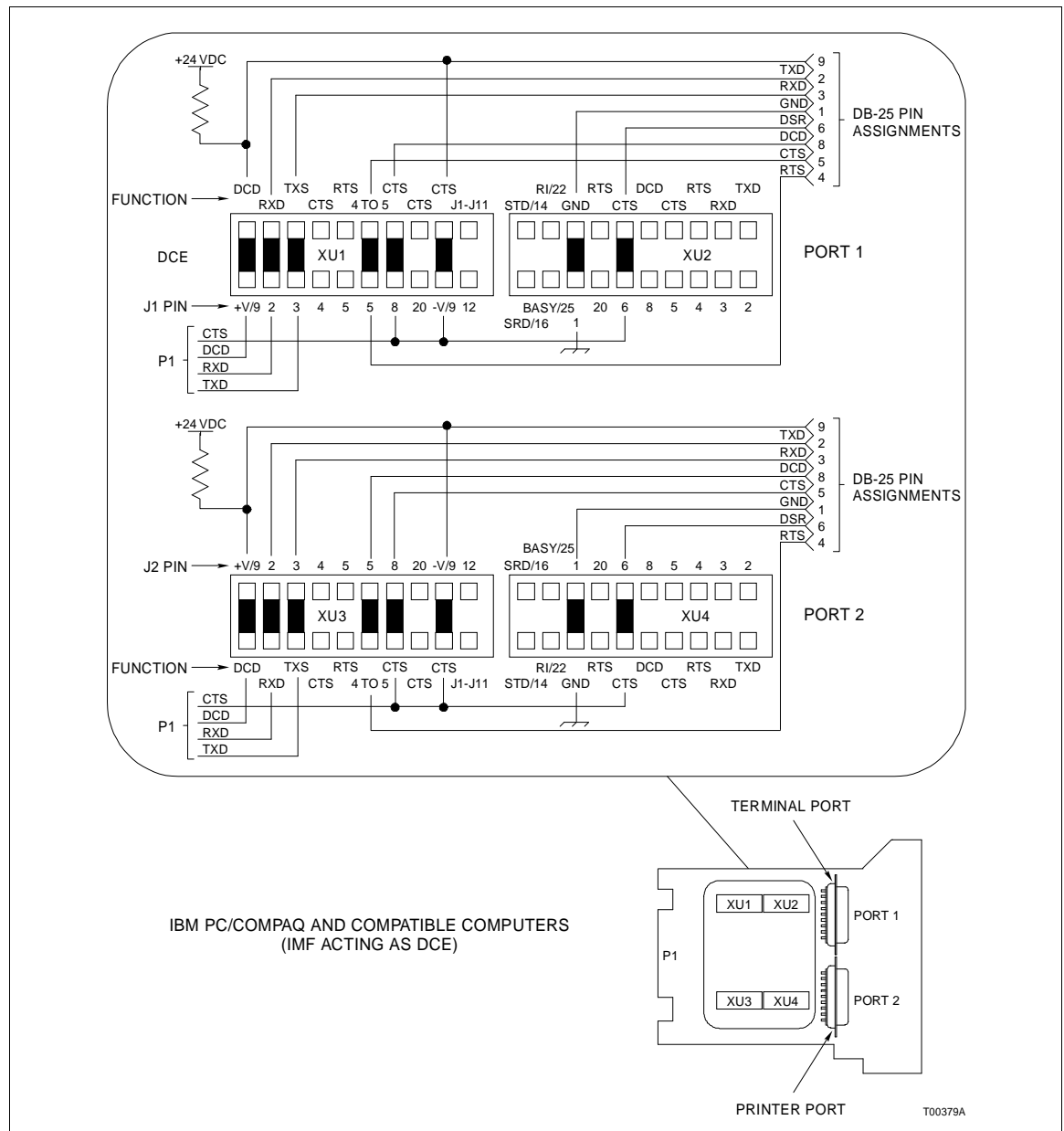

Figure D-1. NIMF01/02 Dipshunt Configuration for Direct Connection to a Host Computer

Figure D-1 shows the dipshunt configuration required when connecting an ICT module (DCE) directly to the host computer (DTE). Figure D-2 shows the dipshunt configuration required when connecting an ICT module (DTE) to a modem (DCE). Figure D-3 shows the dipshunt configuration required to interface to a mainframe computer (VAX). Figure D-4 shows how to configure the IMF unit so that port 2 can drive a diagnostics terminal. Figure D-5 shows the RS-232-C signals and the associated DB-25 connector pin assignments. Refer to the NIMF01 and NIMF02 instruction for complete information.

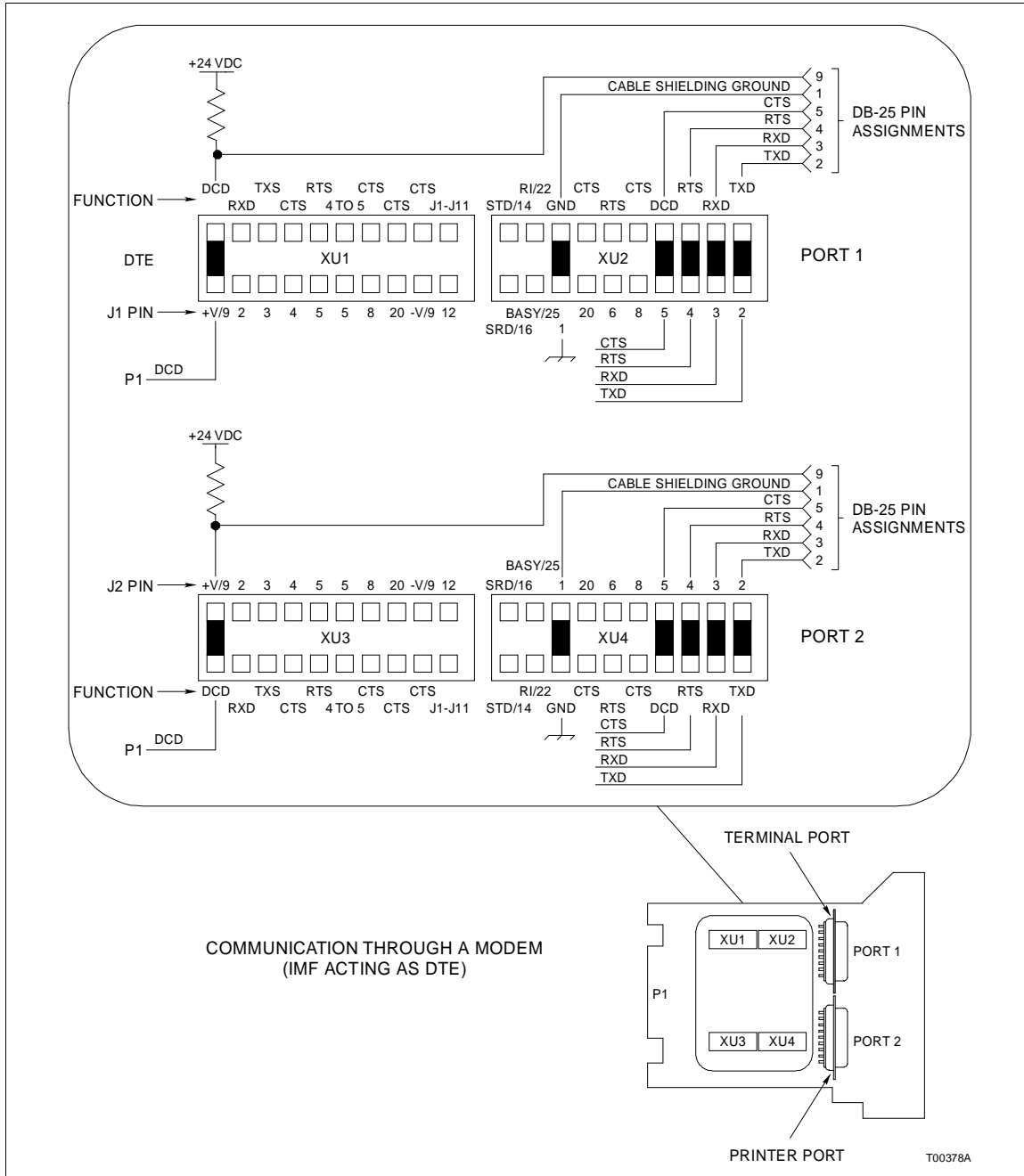

Figure D-2. NIMF01/O2 Dipshunt Configuration for Direct Connection to a Modem

NIMF01/NIMF02 TERMINATION MODULE CONFIGURATION

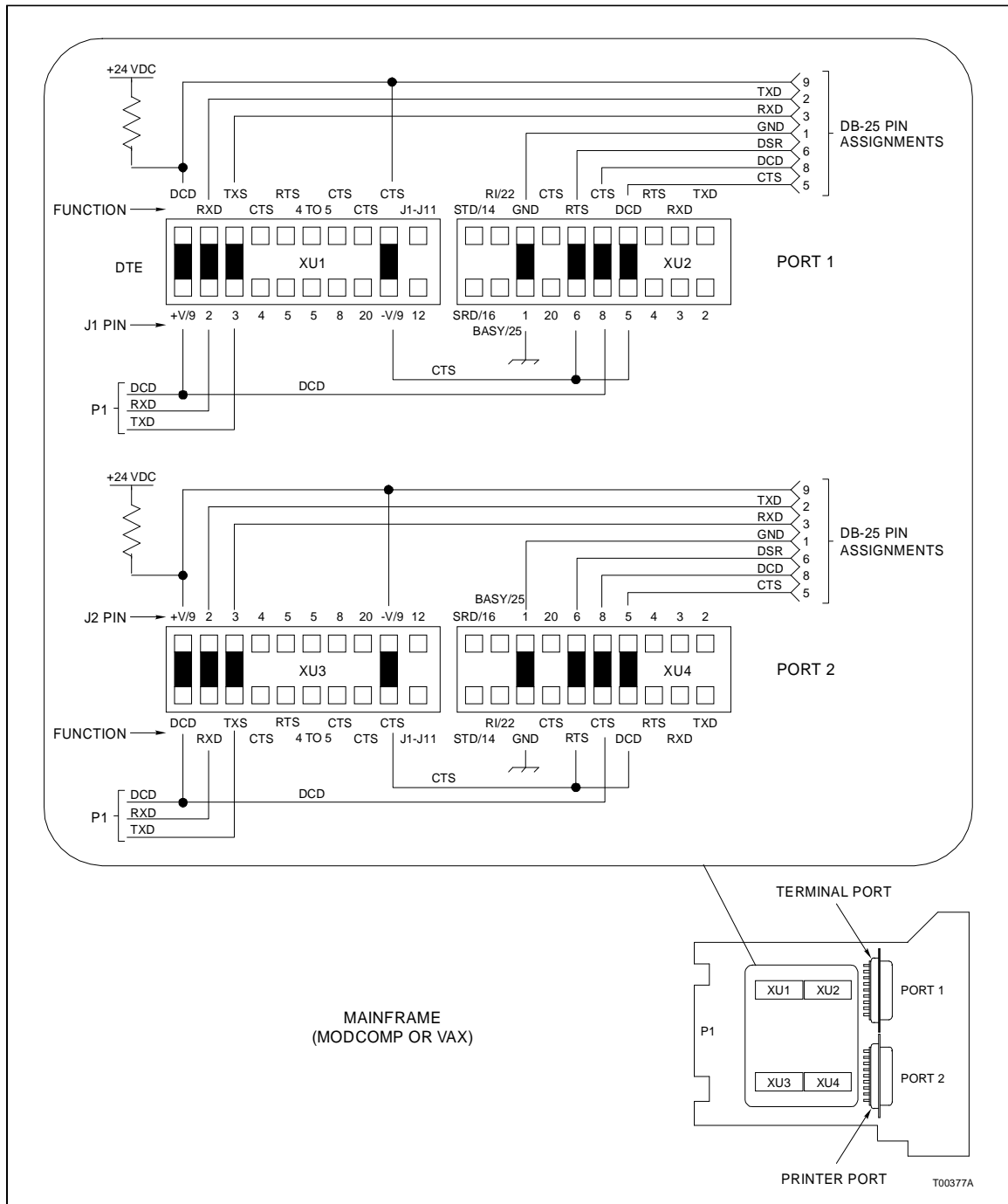

Figure D-3. NIMF01/02 Dipshunt Configuration for Direct Connection to Mainframe Computer

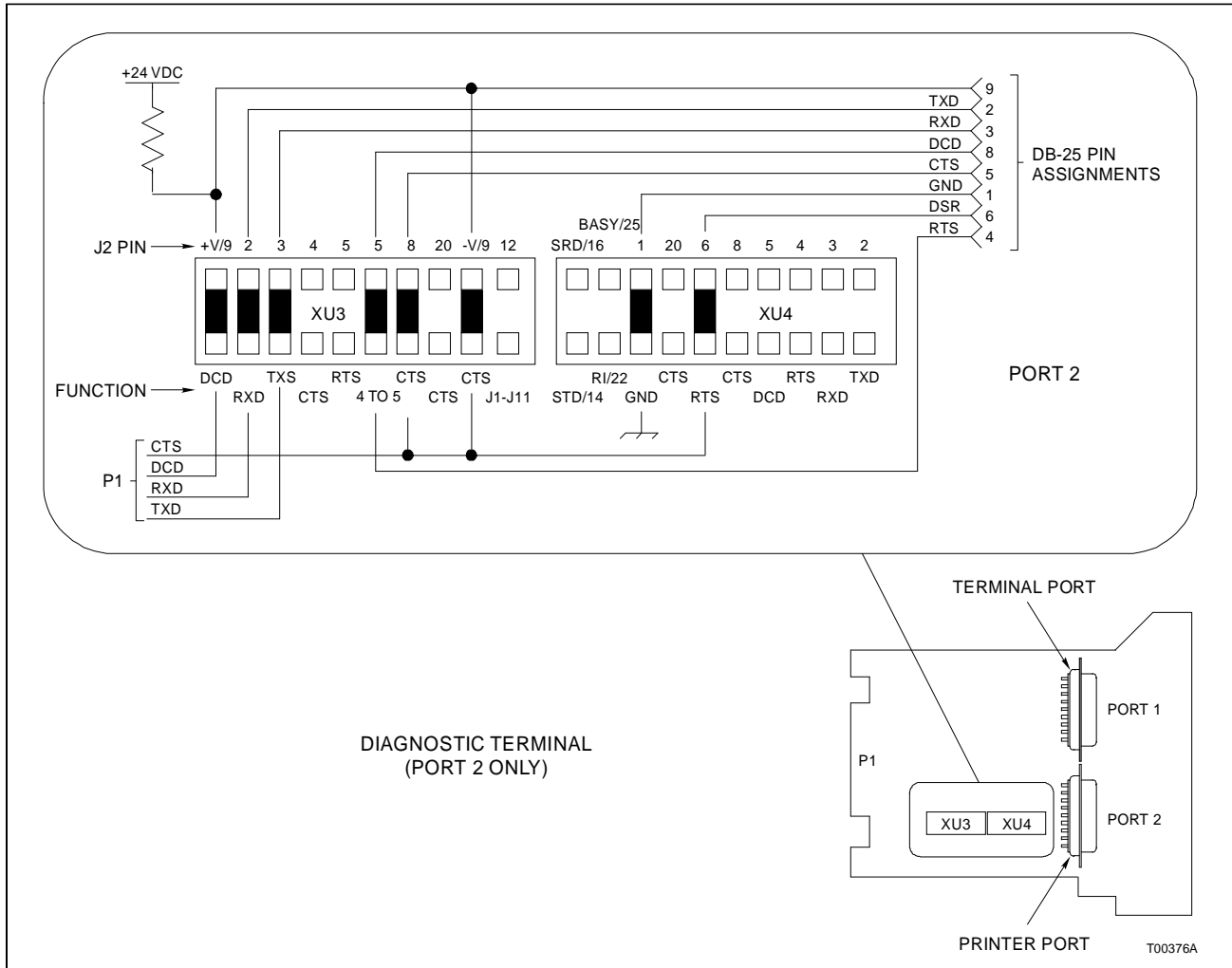

Figure D-4. NIMF01/02 Dipshunt Configuration for Diagnostic Terminal

NIMF01/NIMF02 TERMINATION MODULE CONFIGURATION

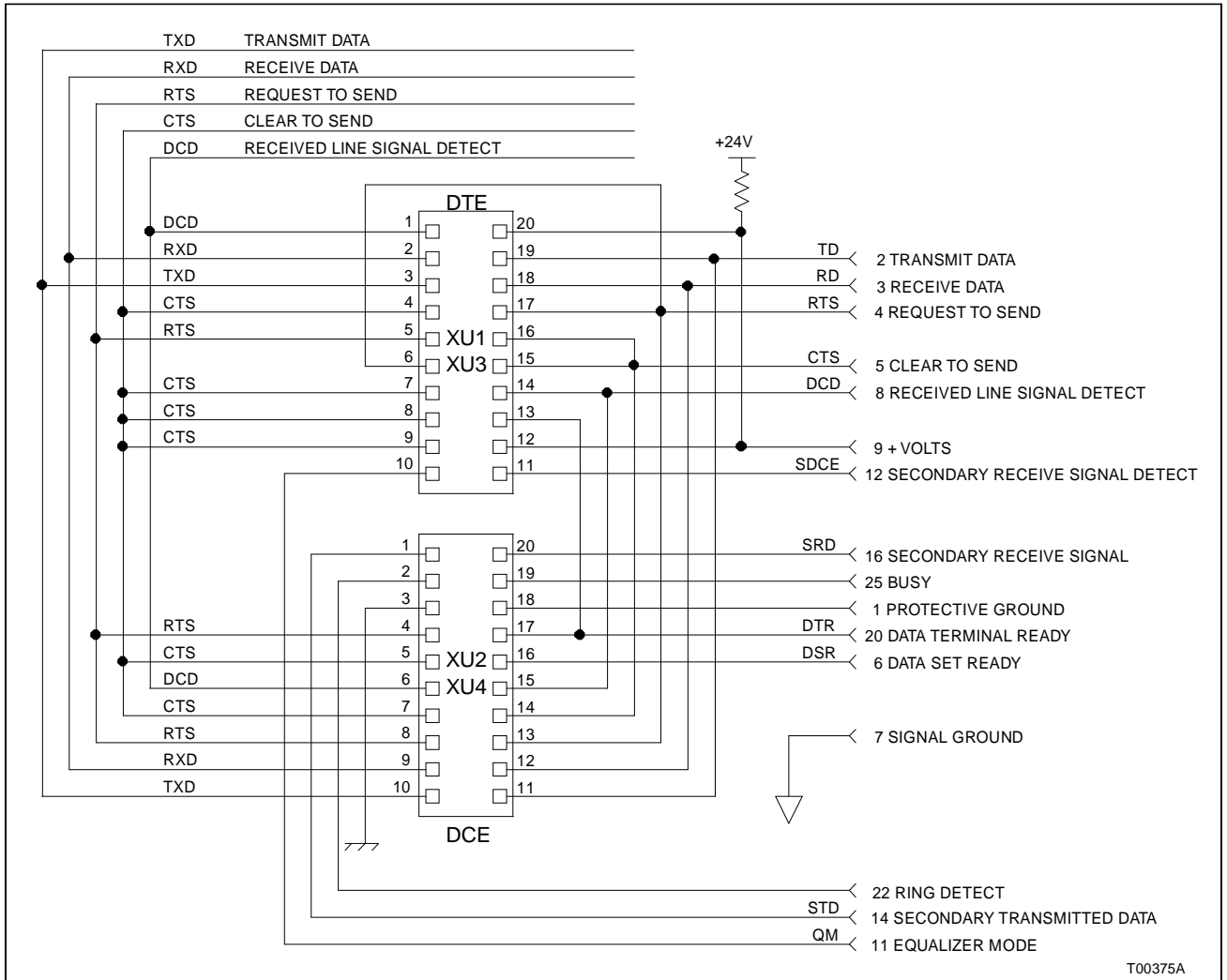

Figure D-5. NIMF01/02 DB-25 Connector Pin Assignments and RS-232-C Signals

T00375A

APPENDIX E - NTMP01 TERMINATION UNIT CONFIGURATION

INTRODUCTION

The INICT03 INFI-NET to Computer Transfer Module (through the IMMPIO1 Multi-Function Processor Interface Module (MPI) can use the NTMP01 termination unit for termination. Jumpers on the TMP unit configure the two RS-232-C ports for data terminal equipment (DTE) or data communication equipment (DCE). One of the RS-232-C ports can be configured as an RS-485 port. Refer to the NTMP01 instruction for complete information.

Figures E-1, E-2, E-3, and E-4 show the jumper configurations for jumpers J1 and J2. Figure E-5 shows the jumper configurations for jumpers J3 through J10. Figure E-6 shows the jumper configurations for jumpers J14 through J17. Figure E-7 shows the NTMP01 connector assignments and jumper locations.

Jumpers J11 and J12 are storage posts for extra jumpers. Jumper J13 is normally set with pins one and two connected. This connects the cable shielding pin of connector P7 to chassis ground. Jumper J18 configures the terminal serial port for RS-485 operation when pins two and three are connected and connector P7 is used instead of connector P5.

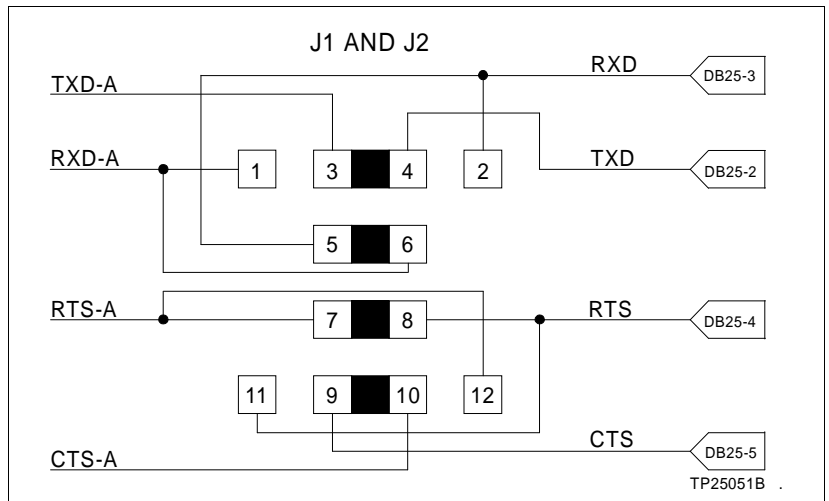

Figure E-1. DTE Jumper Configuration for NTMP01 Termination Unit

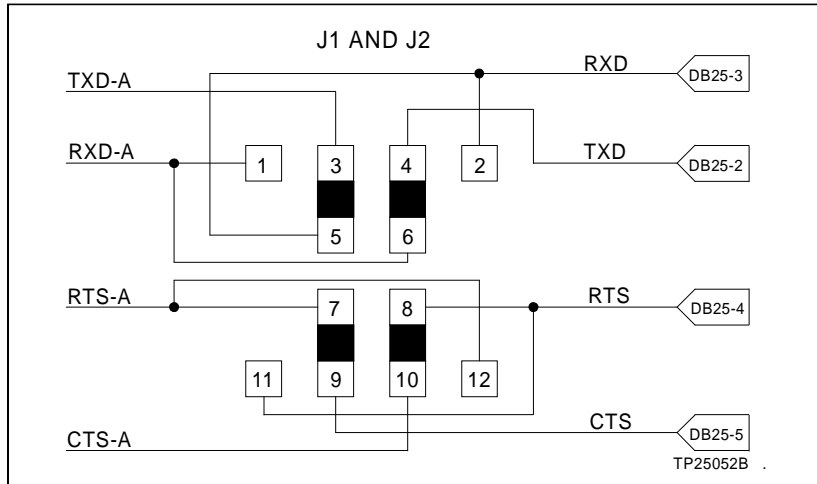

Figure E-2. DCE Jumper Configuration for NTMP01 Termination Unit

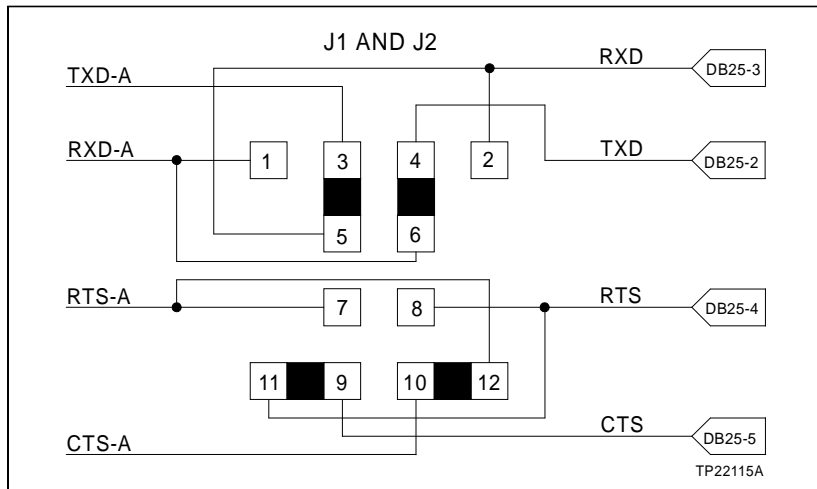

Figure E-3. NTMP01 Nonhandshake Jumper Configuration

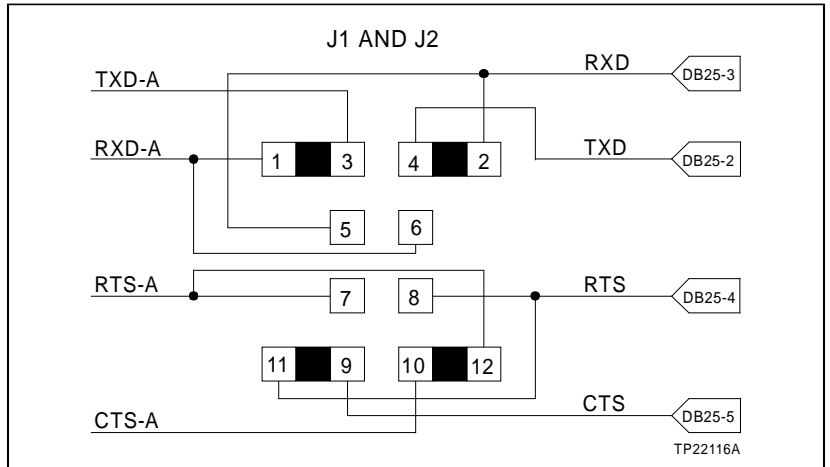

Figure E-4. NTMP01 Loopback Jumper Configuration

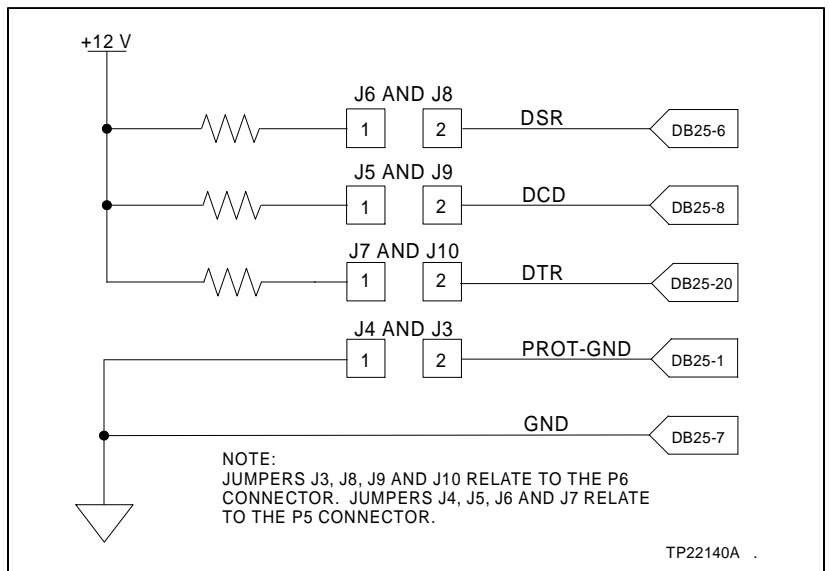

Figure E-5. NTMP01 Jumpers J3 through J10 Configuration

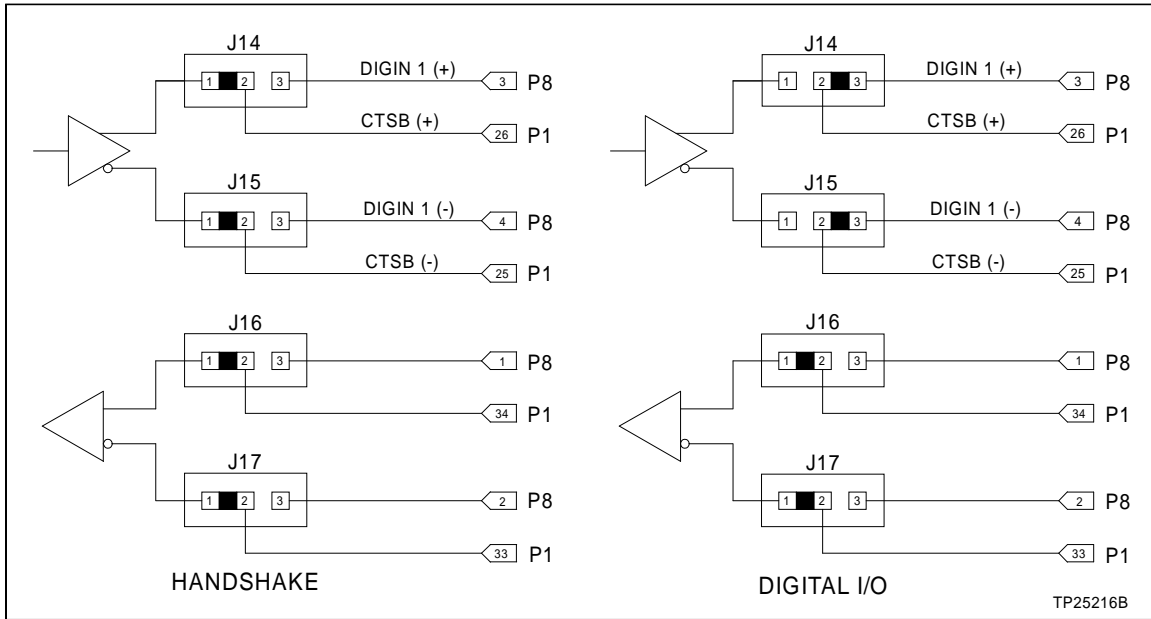

Figure E-6. NTMP01 Jumpers J14 through J17 Configuration

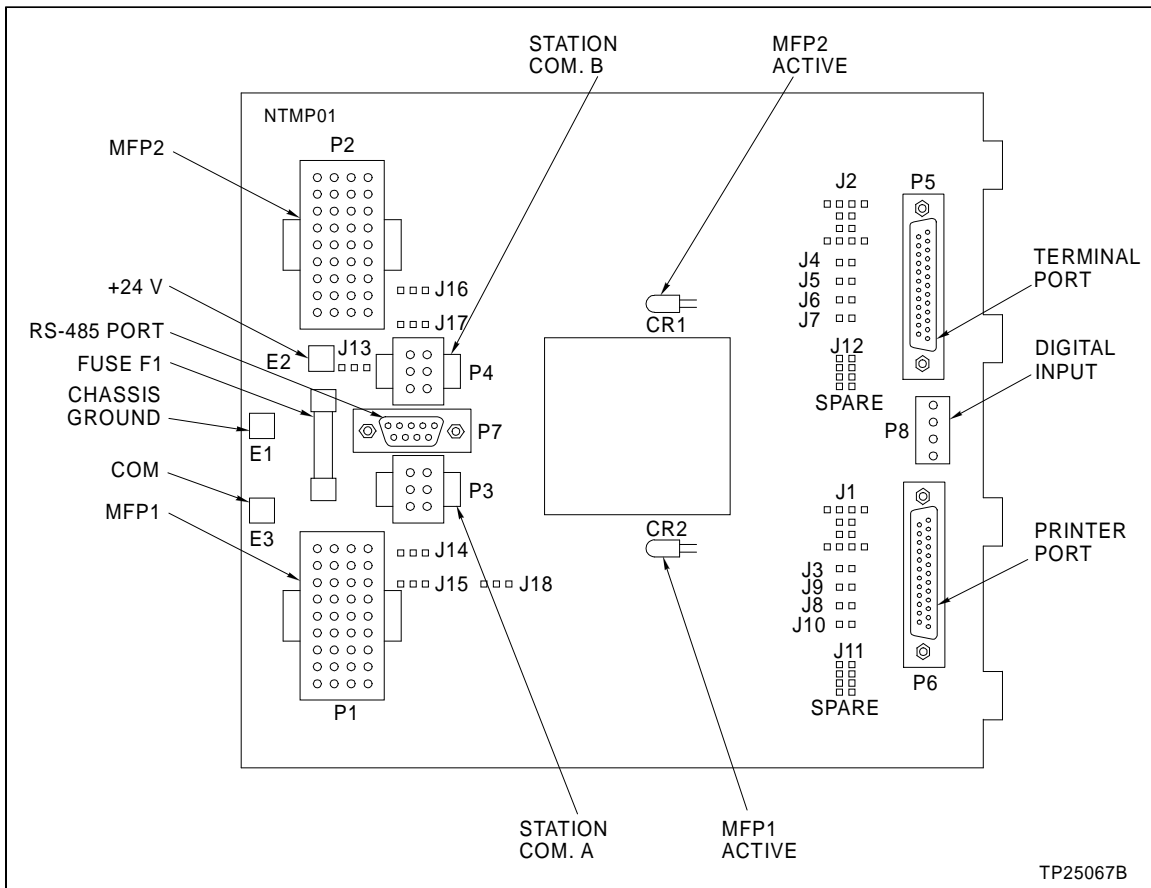

Figure E-7. NTMP01 Connector Assignments and Jumper Locations

APPENDIX F - NIMP01/NIMP02 TERMINATION MODULE CONFIGURATION

INTRODUCTION

The INICT03 INFI-NET to Computer Transfer Module (through the IMMPIO1 Multi-Function Processor Interface Module) can use the NIMP01 and NIMP02 termination module for termination. Jumpers on the NIMP01 module configure the two RS-232-C ports for data terminal equipment (DTE) or data communication equipment (DCE). One of the RS-232-C ports can be configured as an RS-485 port. The NIMP02 module is required when installing redundant ICT modules. Refer to the NIMP01 and NIMP02 instruction for complete information on termination module applications.

Figures F-1, F-2, F-3, and F-4 show the jumper configurations for jumpers J1 and J2. Figure F-5 shows the jumper configurations for jumpers J5 through J10. Figure F-6 shows the jumper configurations for jumpers J14 through J17. Figure F-7 shows the NIMP01 connector and jumper locations.

Jumpers J11 and J12 are storage posts for extra jumpers. Jumper J13 is normally set with pins one and two connected. Jumper J18 configures the terminal serial port for RS-485 operation when pins two and three are connected and connector P7 is used instead of connector P5.

NOTES:

1. RS-232-C port connections on the IMP module are through DB-9 connectors. Use Bailey Controls cable NKMR02 to connect a standard piece of equipment (computer or printer with a DB-25 connector) to the IMP module.
2. There are no jumper settings on the NIMP02 termination module.

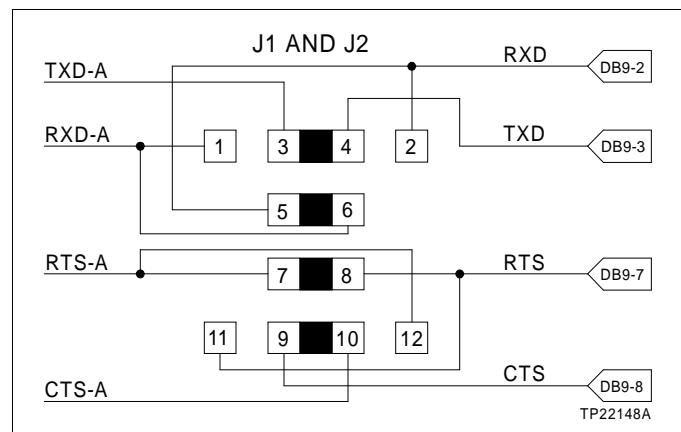

Figure F-1. DTE Jumper Configuration for NIMP01 Termination Module

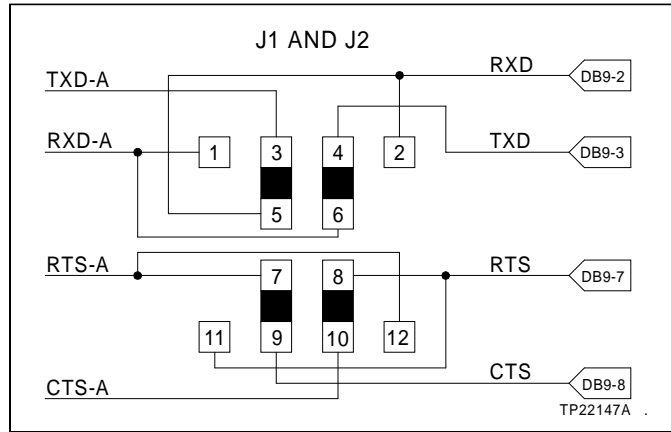

Figure F-2. DCE Jumper Configuration for NIMP01 Termination Module

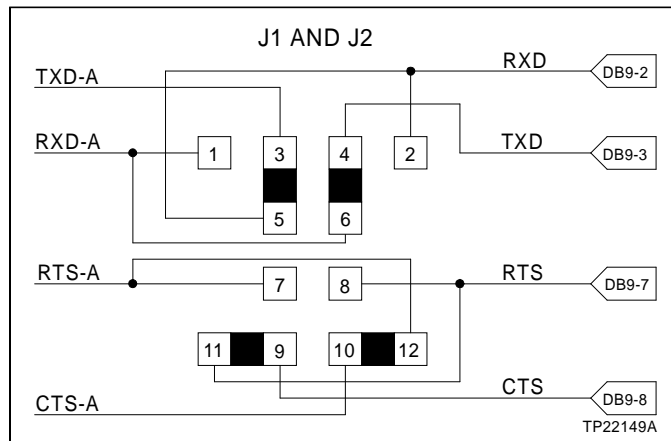

Figure F-3. NIMP01 Nonhandshake Jumper Configuration

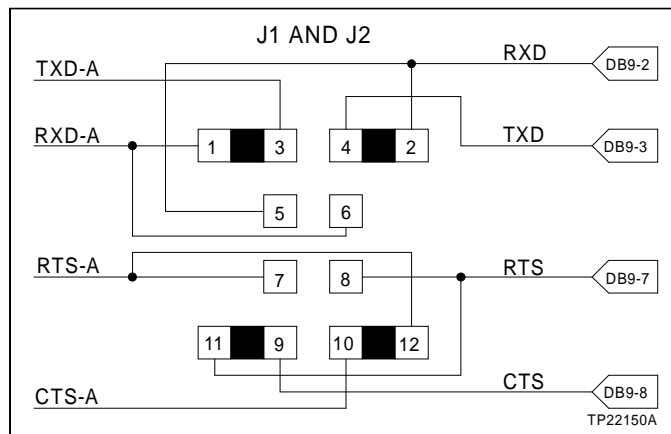

Figure F-4. NIMP01 Loopback Jumper Configuration

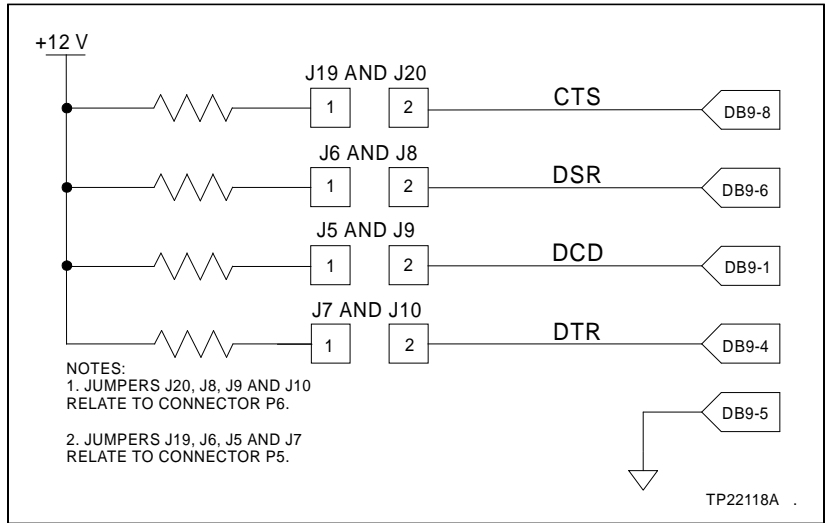

Figure F-5. NIMP01 Jumpers J5 through J10 Configuration

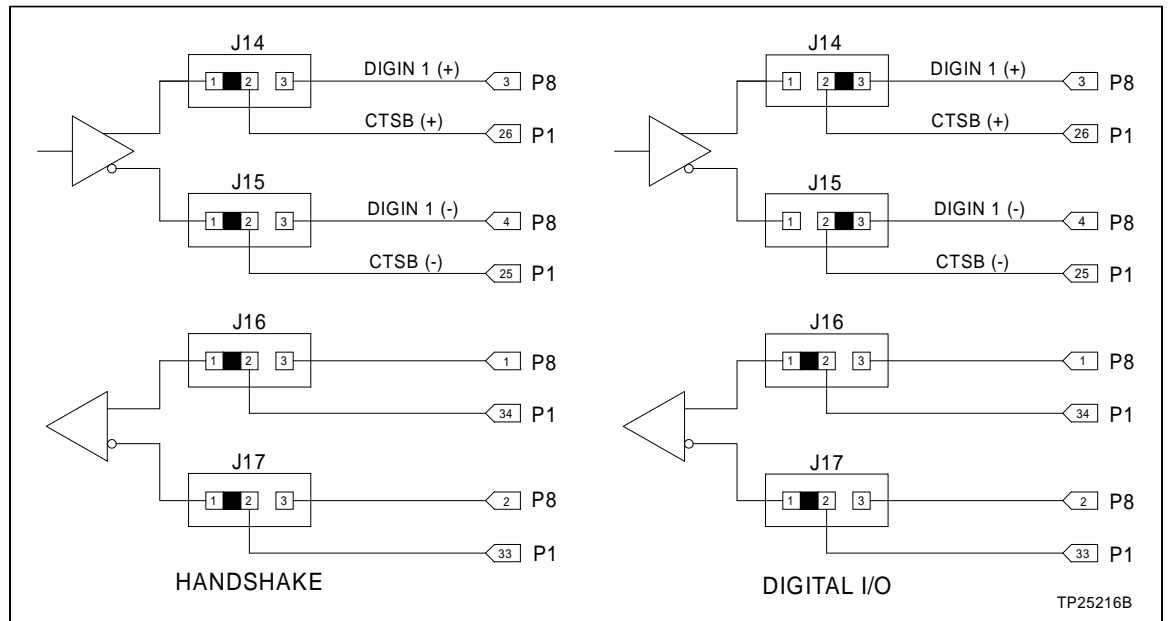

Figure F-6. NIMP01 Jumpers J14 through J17 Configuration

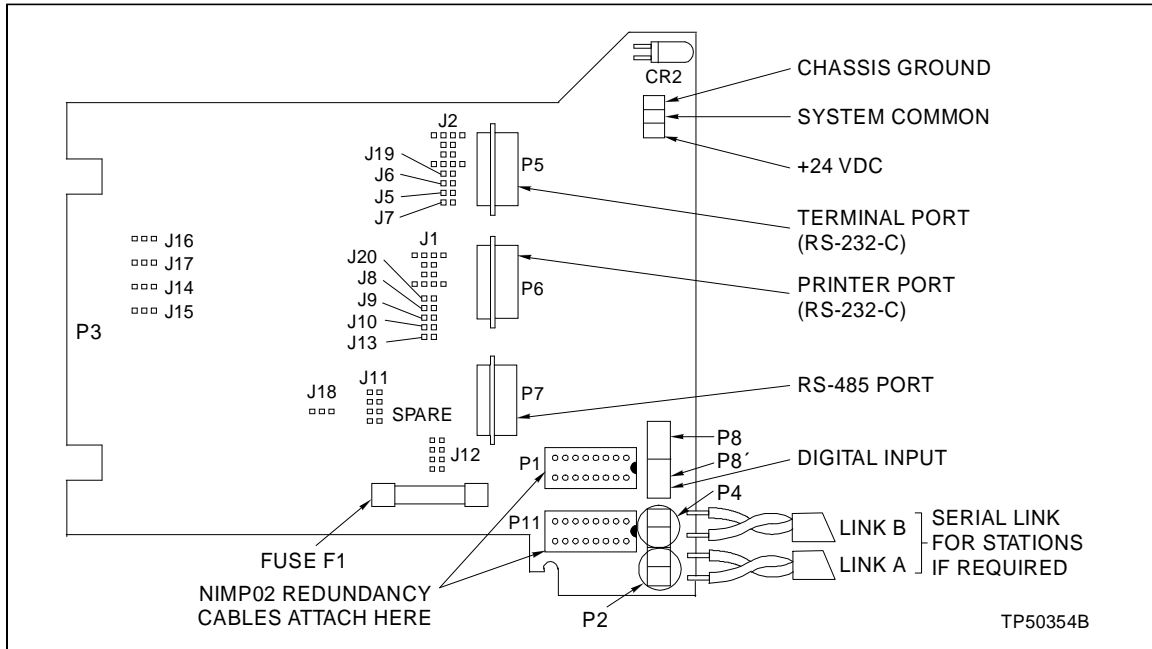

Figure F-7. NIMP01 Connector Assignments and Jumper Locations

Index

A	
Abbreviations	1-6

C	
Computer interface commands	
Configuration	2-6
Data acquisition	2-5
Process control	2-6
System status	2-6
Configuration	
IMMPI01	3-17
NIMP01/02	F-1
NTMP01	E-1
INICT01	3-8
NIMF01/02	D-1
NTMF01	C-1
INICT03	3-13
INNIS01	3-2
NICL01	B-1
NTCL01	A-1

D	
Data integrity	2-3
Description	
IMMPI01	1-4
INICI01	1-1
INICI03	1-1
INICT01	1-3, 2-4
INICT03	1-3, 2-4
INNIS01	1-2, 2-1
Dipshunts	
NIMF01/02	D-1
NTMF01	C-1
Dipswitches	
INICT01	3-9
INICT03	3-13
INNIS01	3-2
Documentation	8-1

E	
Error codes	
INICT01	5-2
INICT03	5-2
INNIS01	5-1
Exception reports	2-1

G	
Glossary	1-6

I	
IMMPI01	
Configuration	3-17
Description	1-4
Edge connectors	5-6
Installation	3-19
Replacement procedures	7-1
Specifications	1-7
Termination device	
NIMP01/02	F-1
NTMP01	E-1
INICI01	
Description	1-1
Operating modes	4-5
INICI03	
Description	1-1
Operating modes	4-5
INICT01	
Configuration	3-8
Description	1-3, 2-4
Edge connectors	5-4
Error codes	5-2
Installation	3-11
LEDs and controls	4-1
Operating modes	4-5
Replacement procedures	7-1
Security functions	4-5
Specifications	1-7
Termination device	
NIMF01/02	D-1
NTMF01	C-1
Utilities	4-6
INICT03	
Configuration	3-13
Description	1-3, 2-4
Edge connectors	5-5
Error codes	5-2
Installation	3-19
LEDs and controls	4-4
Operating modes	4-5
Replacement procedures	7-1
Security functions	4-5
Specifications	1-7
Utilities	4-6

Index (continued)

INNIS01		NIMP01/02 termination module	F-1
Configuration	3-2	Nomenclature	1-6
Description	1-2, 2-1	NTCL01 termination unit.....	A-1
Edge connectors	5-3	NTMF01 termination unit.....	C-1
Error codes.....	5-1	NTMP01 termination unit.....	E-1
Installation	3-7		
LEDs.....	4-1	O	
Replacement procedures	7-1	Operating modes	4-5
Specifications	1-7	Overview.....	1-1
Start-up procedures.....	4-1		
Termination device		R	
NICL01	B-1	Reference documents	1-6
NTCL01	A-1	Replacement	
Installation		Parts	8-1
IMMPI01	3-19	Procedures	7-1
INICT01	3-11		
INICT03	3-19	S	
INNIS01	3-7	Security functions	4-5
		Special handling precautions.....	3-1
J		Specifications	1-7
Jumpers			
IMMPI01	3-18	T	
INICT01	3-9	TALK90.....	4-6
INICT03	3-16	Termination devices	
INNIS01	3-6	NICL01	B-1
NIMP01/02	F-1	NIMF01/02	D-1
NTCL01	A-3	NIMP01/02.....	F-1
NTMP01	E-1	NTCL01	A-1
		NTMF01	C-1
M		NTMP01.....	E-1
Maintenance	6-1	Terms	1-6
Procedures	6-2	Training.....	8-1
Schedule	6-1	Troubleshooting.....	5-1
Tools/equipment required.....	6-2		
Manual content	1-5	U	
Message types	2-2	Unpacking and inspection	3-2
		Utilities	4-6
N			
NICL01 termination module	B-1		
NIMF01/02 termination module.....	D-1		

Visit Elsasg Bailey on the World Wide Web at <http://www.bailey.com>

Our worldwide staff of professionals is ready to meet *your* needs for process automation.
For the location nearest you, please contact the appropriate regional office.

AMERICAS

29801 Euclid Avenue
Wickliffe, Ohio USA 44092
Telephone 1-216-585-8500
Telefax 1-216-585-8756

ASIA/PACIFIC

152 Beach Road
Gateway East #20-04
Singapore 189721
Telephone 65-391-0800
Telefax 65-292-9011

EUROPE, AFRICA, MIDDLE EAST

Via Puccini 2
16154 Genoa, Italy
Telephone 39-10-6582-943
Telefax 39-10-6582-941

GERMANY

Graefstrasse 97
D-60487 Frankfurt Main
Germany
Telephone 49-69-799-0
Telefax 49-69-799-2406