

E96-624

Bailey®
infi 90

Instruction

Plant Loop to Plant Loop Remote Interface (INPPR01)

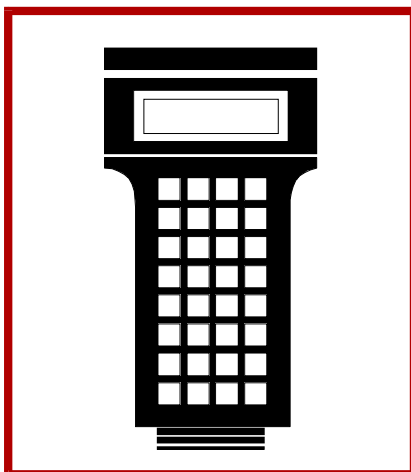
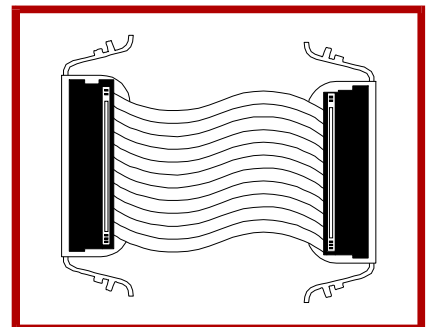
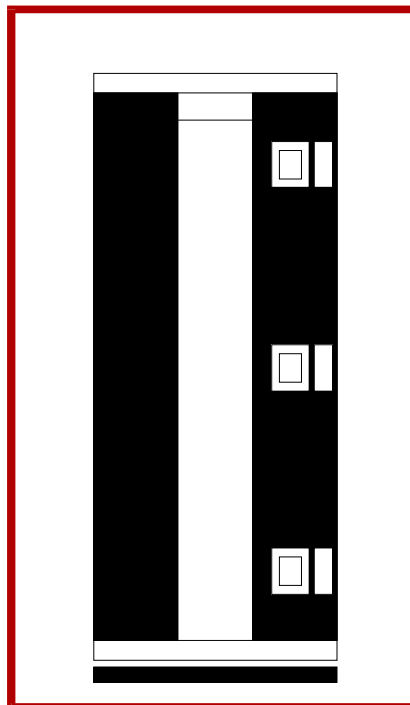
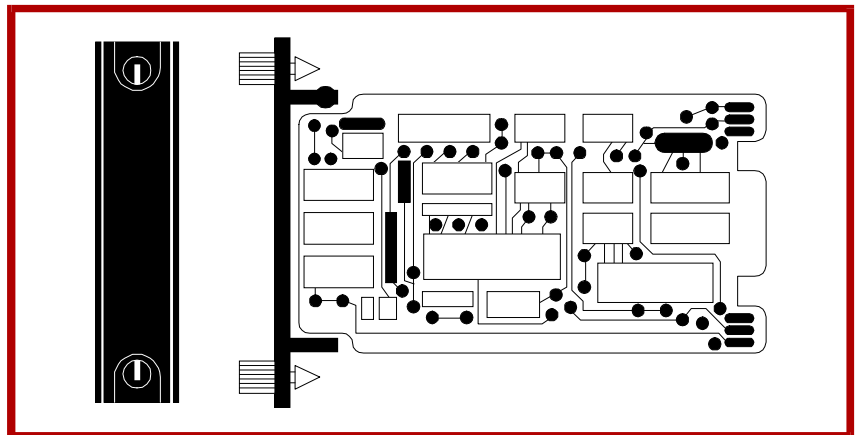
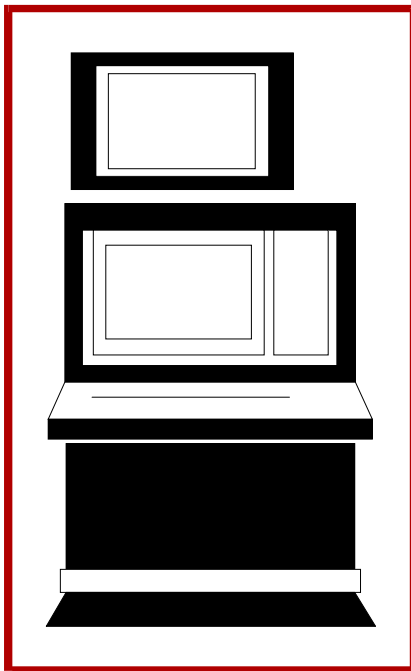

WARNING notices as used in this instruction apply to hazards or unsafe practices that could result in personal injury or death.

CAUTION notices apply to hazards or unsafe practices that could result in property damage.

NOTES highlight procedures and contain information that assists the operator in understanding the information contained in this instruction.

WARNING

INSTRUCTION MANUALS

DO NOT INSTALL, MAINTAIN, OR OPERATE THIS EQUIPMENT WITHOUT READING, UNDERSTANDING, AND FOLLOWING THE PROPER **Elsag Bailey** INSTRUCTIONS AND MANUALS; OTHERWISE, INJURY OR DAMAGE MAY RESULT.

RADIO FREQUENCY INTERFERENCE

MOST ELECTRONIC EQUIPMENT IS INFLUENCED BY RADIO FREQUENCY INTERFERENCE (RFI). CAUTION SHOULD BE EXERCISED WITH REGARD TO THE USE OF PORTABLE COMMUNICATIONS EQUIPMENT IN THE AREA AROUND SUCH EQUIPMENT. PRUDENT PRACTICE DICTATES THAT SIGNS SHOULD BE POSTED IN THE VICINITY OF THE EQUIPMENT CAUTIONING AGAINST THE USE OF PORTABLE COMMUNICATIONS EQUIPMENT.

POSSIBLE PROCESS UPSETS

MAINTENANCE MUST BE PERFORMED ONLY BY QUALIFIED PERSONNEL AND ONLY AFTER SECURING EQUIPMENT CONTROLLED BY THIS PRODUCT. ADJUSTING OR REMOVING THIS PRODUCT WHILE IT IS IN THE SYSTEM MAY UPSET THE PROCESS BEING CONTROLLED. SOME PROCESS UPSETS MAY CAUSE INJURY OR DAMAGE.

AVERTISSEMENT

MANUELS D'OPÉRATION

NE PAS METTRE EN PLACE, RÉPARER OU FAIRE FONCTIONNER L'ÉQUIPEMENT SANS AVOIR LU, COMPRIS ET SUIVI LES INSTRUCTIONS RÉGLEMENTAIRES DE **Elsag Bailey**. TOUTE NÉGLIGENCE À CET ÉGARD POURRAIT ÊTRE UNE CAUSE D'ACCIDENT OU DE DÉFAILLANCE DU MATÉRIEL.

PERTURBATIONS PAR FRÉQUENCE RADIO

LA PLUPART DES ÉQUIPEMENTS ÉLECTRONIQUES SONT SENSIBLES AUX PERTURBATIONS PAR FRÉQUENCE RADIO. DES PRÉCAUTIONS DEVRONT ÊTRE PRISES LORS DE L'UTILISATION DU MATÉRIEL DE COMMUNICATION PORTATIF. LA PRUDENCE EXIGE QUE LES PRÉCAUTIONS À PRENDRE DANS CE CAS SOIENT SIGNALÉES AUX ENDROITS VOULUS DANS VOTRE USINE.

PERTURBATIONS DU PROCÉDÉ

L'ENTRETIEN DOIT ÊTRE ASSURÉ PAR UNE PERSONNE QUALIFIÉE EN CONSIDÉRANT L'ASPECT SÉCURITAIRE DES ÉQUIPEMENTS CONTRÔLÉS PAR CE PRODUIT. L'AJUSTEMENT ET/OU L'EXTRACTION DE CE PRODUIT PEUT OCCASIONNER DES À-COUPS AU PROCÉDÉ CONTRÔLE LORSQU'IL EST INSÉRÉ DANS UNE SYSTÈME ACTIF. CES À-COUPS PEUVENT ÉGALEMENT OCCASIONNER DES BLESSURES OU DES DOMMAGES MATÉRIELS.

NOTICE

The information contained in this document is subject to change without notice.

Elsag Bailey, its affiliates, employees, and agents, and the authors and contributors to this publication specifically disclaim all liabilities and warranties, express and implied (including warranties of merchantability and fitness for a particular purpose), for the accuracy, currency, completeness, and/or reliability of the information contained herein and/or for the fitness for any particular use and/or for the performance of any material and/or equipment selected in whole or part with the user of/or in reliance upon information contained herein. Selection of materials and/or equipment is at the sole risk of the user of this publication.

This document contains proprietary information of Elsag Bailey, Elsag Bailey Process Automation, and is issued in strict confidence. Its use, or reproduction for use, for the reverse engineering, development or manufacture of hardware or software described herein is prohibited. No part of this document may be photocopied or reproduced without the prior written consent of Elsag Bailey.

Preface

The Plant Loop to Plant Loop Remote Interface (INPPR01) enables communication between a local and remote Plant Loop. The interface consists of three modules, the Plant Loop to Plant Loop Transfer Module (INPPT01), the Bus Transfer Module (INBTM01) and the Loop Interface Module (INLIM03). Plant Loop to Plant Loop Remote Interfaces connect through cable, modem or microwave link.

This instruction explains PPR features, specifications, and operation. It also includes installation and troubleshooting procedures for the interface.

The system engineer or technician using the INPPR01 should read and understand this instruction before installing the interface modules. In addition, a complete understanding of the INFI 90 system is beneficial to the user.

List of Effective Pages

Total number of pages in this manual is **62**, consisting of the following:

Page No.	Change Date
Preface	Original
List of Effective Pages	Original
iii through viii	Original
1-1 through 1-6	Original
2-1 through 2-4	Original
3-1 through 3-13	Original
4-1 through 4-10	Original
5-1 through 5-5	Original
6-1	Original
7-1	Original
8-1	Original
A-1 through A-5	Original
B-1 through B-2	Original
C-1 through C-4	Original
D-1 through D-2	Original

When an update is received, insert the latest changed pages and dispose of the superseded pages.

NOTE: On an update page, the changed text or table is indicated by a vertical bar in the outer margin of the page adjacent to the changed area. A changed figure is indicated by a vertical bar in the outer margin next to the figure caption. The date the update was prepared will appear beside the page number.

Safety Summary

**GENERAL
WARNINGS**

Equipment Environment

All components, whether in transportation, operation or storage must be in a noncorrosive environment.

Electrical Shock Hazard During Maintenance

Disconnect power or take precautions to ensure that contact with energized parts is avoided when servicing.

Special Handling

This unit uses Electrostatic Sensitive Devices (ESD).

**SPECIFIC
WARNINGS**

Disconnect power before installing dipshunts for slave modules on the MMU backplane (slave expander bus). Failure to do so could result in severe or fatal shock. (p. 3-10)

**SPECIFIC
CAUTIONS**

Ensure that the cable end marked J1 is connected to P1 on the NICL01, and J2 is connected to the LIM. Failure to do so could result in module damage (see Figure D-1). (p. D-1)

Sommaire de Sécurité

**AVERTISSEMENTS
D'ORDRE
GÉNÉRAL****Environnement de l'équipement**

Ne pas soumettre les composants à une atmosphère corrosive lors du transport, de l'entreposage ou de l'utilisation.

Risques de chocs électriques lors de l'entretien

S'assurer de débrancher l'alimentation ou de prendre les précautions nécessaires à éviter tout contact avec des composants sous tension lors de l'entretien.

Précautions de manutention

Ce module contient des composants sensibles aux décharges électro-statiques.

**AVERTISSEMENTS
D'ORDRE
SPÉCIFIQUE**

Couper l'alimentation avant d'installer les dipshunts sur la plaque arrière du châssis de montage de modules (MMU). Toute négligence à cet égard constitue un risque de choc pouvant entraîner des blessures graves, voire mortelles. (p. 3-10)

**ATTENTIONS
D'ORDRE
SPÉCIFIQUE**

S'assurer que l'extrémité identifiée par J1 est reliée à P1 du module NICL01 et que J2 est reliée au module LIM. Sinon, les modules pourraient être endommagés (voir la figure D-1). (p. D-1)

Table of Contents

	<i>Page</i>
SECTION 1 - INTRODUCTION	1-1
OVERVIEW	1-1
INTENDED USER	1-1
HARDWARE DESCRIPTION	1-2
Plant Loop to Plant Loop Transfer Module (INPPT01)	1-2
Bus Transfer Module (INBTM01)	1-2
Loop Interface Module (INLIM03)	1-2
Additional Hardware	1-2
FEATURES	1-2
INSTRUCTION CONTENT	1-3
HOW TO USE THIS MANUAL	1-3
GLOSSARY OF TERMS AND ABBREVIATIONS	1-4
REFERENCE DOCUMENTS	1-5
NOMENCLATURE	1-5
SPECIFICATIONS	1-6
SECTION 2 - DESCRIPTION AND OPERATION	2-1
INTRODUCTION	2-1
LOCAL/REMOTE COMMUNICATIONS	2-1
DATA INTEGRITY	2-2
TIMING INTERVAL	2-2
Transmit/Receive Timing	2-3
SECTION 3 - INSTALLATION	3-1
INTRODUCTION	3-1
SPECIAL HANDLING	3-1
UNPACKING AND INSPECTION	3-1
INPPT01 SWITCH SETTINGS	3-1
Option Switch (U72)	3-2
Serial Port Communication Rate (U73)	3-3
Loop Address (U75)	3-4
INLIM03 SWITCH SETTINGS	3-5
INBTM01 SWITCH SETTINGS	3-7
TERMINATION UNIT (MODULE) CONFIGURATION	3-8
NTMF01/NIMF01/NIMF02 Configuration	3-8
One-way Control	3-8
Two-way Control	3-10
NTCL01/NICL01 Configuration	3-10
INSTALLING THE INTERFACE MODULES	3-10
Installing the INPPT01	3-10
Installing the INLIM03 and INBTM01	3-11
INSTALLING A REDUNDANT INTERFACE	3-12
INTERFACE CONFIGURATION	3-12
SECTION 4 - OPERATING PROCEDURES	4-1
INTRODUCTION	4-1
PLANT LOOP TO PLANT LOOP TRANSFER MODULE LEDs AND CONTROLS	4-1
Status LED	4-2
CPU LEDs	4-2
Memory LEDs	4-2

Table of Contents (continued)

	<i>Page</i>
<hr/>	
SECTION 4 - OPERATING PROCEDURES (continued)	
Stop Pushbutton	4-2
Reset Pushbutton	4-2
LOOP INTERFACE MODULE LEDs	4-3
BUS TRANSFER MODULE LED	4-3
MODES OF OPERATION	4-3
Configure Mode	4-4
Execute Mode	4-4
Error Mode	4-5
One-Way Control	4-5
Two-Way Control	4-6
REDUNDANT INTERFACE OPERATION	4-6
INTERFACE POINT CAPACITY	4-7
MEMORY USAGE EXAMPLE	4-8
Memory Usage in the Local PPT	4-8
Memory Usage in the Remote PPT	4-8
SECURITY FUNCTIONS	4-9
Hardware Checks	4-9
Software Checks	4-9
Utilities	4-9
<hr/>	
SECTION 5 - TROUBLESHOOTING	5-1
INTRODUCTION	5-1
Status Bytes	5-2
<hr/>	
SECTION 6 - MAINTENANCE	6-1
INTRODUCTION	6-1
MAINTENANCE SCHEDULE	6-1
<hr/>	
SECTION 7 - REPAIR/REPLACEMENT PROCEDURES	7-1
INTRODUCTION	7-1
MODULE REPAIR/REPLACEMENT	7-1
<hr/>	
SECTION 8 - SUPPORT SERVICES	8-1
INTRODUCTION	8-1
REPLACEMENT PARTS AND ORDERING INFORMATION	8-1
TRAINING	8-1
TECHNICAL DOCUMENTATION	8-1
<hr/>	
APPENDIX A - TERMINATION UNIT CONFIGURATION (NTMF01)	A-1
INTRODUCTION	A-1
<hr/>	
APPENDIX B - TERMINATION UNIT CONFIGURATION (NTCL01)	B-1
INTRODUCTION	B-1
<hr/>	
APPENDIX C - TERMINATION MODULE CONFIGURATION (NIMF01/NIMF02)	C-1
INTRODUCTION	C-1

Table of Contents (continued)

	<i>Page</i>
APPENDIX D - TERMINATION MODULE CONFIGURATION (NICL01)	D-1
INTRODUCTION.....	D-1

List of Figures

<i>No.</i>	<i>Title</i>	<i>Page</i>
1-1.	Diagram of Plant Loop to Plant Loop Remote Interfaces in Two-Way Control Mode ..	1-1
2-1.	Send/Receive Timing Diagram	2-4
3-1.	Switch Locations on the PPT (CPU board)	3-2
3-2.	LIM Switch Locations	3-5
3-3.	BTM Switch (SW1) Location	3-7
3-4.	NTMF01 and NTCL01 in a Redundant Installation	3-9
3-5.	NIMF01/NIMF02 and NICL01 in a Redundant Installation	3-9
3-6.	Redundant Transceiver	3-13
4-1.	PPT Faceplate LEDs	4-1
4-2.	LIM Faceplate LEDs	4-3
4-3.	BTM Faceplate LEDs	4-4
4-4.	Local Plant Loop Using Bosth Serial Ports in One-Way Control	4-5
4-5.	Local and Remote Plant Loops in Two-Way Control	4-6
4-6.	PPT Utilities Menu	4-10
A-1.	Dipshunt Configuration for PPT Acting as DTE (Requires Modem or Other DCE) ...	A-1
A-2.	Dipshunt Configuration for Direct Connection with Local PPT Acting as DTE	A-2
A-3.	Dipshunt Configuration for Direct Connection with Remote PPT Acting as DCE	A-3
A-4.	Disphunt Configuration for Diagnostic Terminal (Port 1 only)	A-4
A-5.	DB-25 Pin Assignments and RS-232-C Signals	A-5
B-1.	NTCL01 Termination Unit and Terminal Assignments	B-2
C-1.	Dipshunt Configuration for PPT Acting as DTE (requires Modem or Other DCE) ...	C-1
C-2.	Dipshunt Configuration for Direct Connection of Local PPT Acting as DTE	C-2
C-3.	Dipshunt Configuration for Direct Connection of Remote PPT Acting as DCE	C-3
C-4.	Disphunt Configuration for Diagnostic Terminal	C-4
D-1.	Typical Twinax Cable Connection for the NICL01	D-2

List of Tables

<i>No.</i>	<i>Title</i>	<i>Page</i>
3-1.	Option Switch (U72) Settings	3-2
3-2.	Serial Port Communication Rate (U73)	3-3
3-3.	Message Throughput	3-4
3-4.	U75 Loop Addresses	3-4
3-5.	LIM Event Counter Addresses (SW1)	3-5
3-6.	LIM Error Counter Addresses (SW1)	3-6
3-7.	LIM Node Address Setting (SW2)	3-7
3-8.	BTM Options (SW1)	3-8
3-9.	INPPR01 Function Codes	3-13
4-1.	PPT Status LED States	4-2
4-2.	BTM Status LEDs States	4-4
4-3.	Memory Usage in Receiving Communication	4-7
4-4.	Memory Usage in Sending Communication	4-8
5-1.	PPT Error Codes	5-1
5-2.	Status Bytes	5-2
5-3.	Status Byte Definitions	5-3
5-4.	LIM Edge Connector P3 Pin Assignments	5-3
5-5.	BTM Edge Connector P1 Pin Assignments	5-4
5-6.	PPT CPU Board Edge Connector P2 Pin Assignments	5-4
5-7.	PPT CPU Board Edge Connector P3 Pin Assignments	5-4
6-1.	Maintenance Schedule.....	6-1
B-1.	NTCL01 Terminal Assignments	B-1
B-2.	BNC Terminal Assignments	B-1
B-3.	Jumper Settings and Cable Types	B-2
D-1.	NICL01 Terminal Assignments.....	D-1
D-2.	BNC Assignments	D-1
D-3.	Jumper Settings and Cable Types	D-2

SECTION 1 - INTRODUCTION

OVERVIEW

The Plant Loop to Plant Loop Remote Interface (INPPR01) enables communication between a local and remote Plant Loop. Two modes (user-selectable) of control are available. A local Plant Loop is able to issue control commands and receive Exception Report (XR) data from up to 32 remote Plant Loops when it is in the one-way mode. Only the local Plant Loop can initiate control commands and request exception reports in the one-way mode. The two-way mode connects only two Plant Loops. In the two-way mode, either Plant Loop is able to initiate control commands and request exception reports. Plant Loop to Plant Loop Remote Interfaces can connect through cable, modem or microwave link. Figure 1-1 shows a block diagram of Plant Loop to Plant Loop Remote Interfaces in two-way control. The INPPR01 is a direct replacement of the Network 90 Plant Loop to Plant Loop Gateway (NPPG02).

INTENDED USER

System engineers and technicians should read this manual before installing and operating the INPPR01 module. Refer to the **Table of Contents** to find specific information after the module is operating.

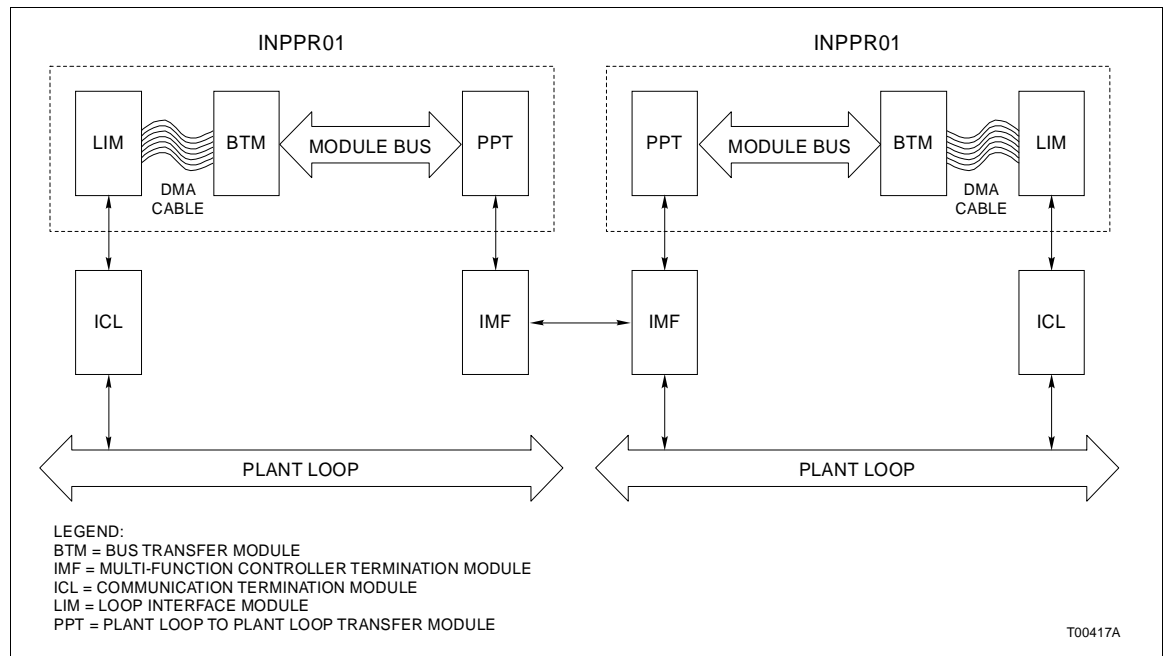

Figure 1-1. Diagram of Plant Loop to Plant Loop Remote Interfaces in Two-Way Control Mode

HARDWARE DESCRIPTION

The Plant Loop to Plant Loop Remote Interface acts as another node on the Plant Loop. The interface consists of three modules on a dedicated module bus.

Plant Loop to Plant Loop Transfer Module (INPPT01)

This module processes incoming and outgoing Plant Loop messages, buffers data and communicates with other PPT modules in remote Plant Loops. The PPT is a double circuit board module. It has a memory board and CPU board. The user selects general operating characteristics and point definitions through software configuration. Other characteristics such as type of control (one-way or two-way), Node ID and port options are user-configured through dipswitches on the CPU board.

Bus Transfer Module (INBTM01)

The BTM is responsible for translating messages from the LIM and placing them on the module bus. It also receives messages from the PPT. It translates those messages and sends them to the LIM through a direct memory access (DMA) cable.

Loop Interface Module (INLIM03)

The LIM provides the communication link between the Plant Loop and the PPT. It receives messages from Plant Loop nodes and monitors loop status. The LIM forwards messages from the loop to the PPT (through the BTM) via a direct memory access (DMA) cable. Additionally, it receives messages from the PPT (through the BTM) and sends them to the proper node on the loop.

Additional Hardware

Some applications require additional hardware such as a modem network, radio link or microwave link. This hardware is not part of the INPPR01 standard hardware. INFI 90 Digital Slave Modules (IMDSO01 through IMDSO04, IMDSM05) support control signals to these devices.

FEATURES

The Plant Loop to Plant Loop Remote Interface provides communication between a local loop and one or more remote loops. This interface has user selectable control modes. Selecting the one-way mode enables a local loop to receive exception reports from up to 32 remote loops. In the one-way mode, only the local loop can initiate control commands. The two-way mode enables bidirectional control and exception reporting between

a local and one remote loop. This interface handles a maximum capacity of 5,000 blocks of exception report data.

The INPPRO1 can handle a mixture of point types. Point types include analog and digital station, remote control memory, manual set constant and device driver. The user can select the interface communication rate, up to 19.2 kbaud.

INSTRUCTION CONTENT

This document is divided into eight sections. **Introduction** provides an overview of the individual modules of the PPR, a list of related documents, glossary of terms and abbreviations and specifications. **Description and Operation** explains how PPR communication occurs. **Installation** covers preliminary module setup, physical installation and configuration. **Operating Procedures** explains faceplate LEDs, controls and interface operating modes. **Troubleshooting** explains how to troubleshoot problems with the interface modules using error codes and status byte information and lists the corrective action. **Maintenance** contains a maintenance schedule for the slave module. **Repair/Replacement Procedures** explain how to replace the PPR modules. **Support Services** explains the customer training Bailey Controls Company provides and information about ordering replacement parts.

HOW TO USE THIS MANUAL

Read this manual in sequence. It is important to become familiar with the entire contents of this manual before using the PPR. The organization of this manual enables the user to find needed information quickly.

1. Read and do the steps in **Section 3**.
2. Read **Section 4** thoroughly before powering up the station.
3. Refer to **Section 5** if a problem occurs.
4. Refer to **Section 6** for scheduled maintenance requirements.
5. Use the **Section 8** for a list of replacement parts and warranty information.

GLOSSARY OF TERMS AND ABBREVIATIONS

Term	Definition
DCE	Data Circuit-Terminating Equipment - The termination point of a communication circuit such as a line driver or modem.
DTE	Data Terminal Equipment - End-user machine of a communication circuit such as a terminal or computer.
Dipshunt	A dual in-line package with shorting bars.
EWS	Engineering Work Station - An integrated hardware and software personal computer system for configuring and monitoring INFI 90/Network 90 modules.
Module Bus	The serial communication link between a process control module and other process control modules.
Node	Device(s) on the INFI 90/Network 90 Plant Loop, Superloop or INFI-NET (maximum of 63 on Plant Loop, 250 on Superloop/INFI-NET). A node can be an Operator Interface Station (OIS), a Process Control Unit (PCU) or Engineering Work Station (EWS) in any combination.
OIS	Operator Interface Station - Integrated operator console with data acquisition and reporting capabilities. It provides a window into the process for flexible control and monitoring.
PCI	Plant Loop to Computer Interface (INPCI01/02) - A Plant Loop communication interface that provides configuration and control of the Plant Loop through a host computer.
PCU	Process Control Unit - Rack type industrial cabinet that contains master, slave and communication modules and their communication paths.
Plant Loop	INFI 90 data communication highway with 63 node capacity.
RS-232-C	One in a series of standards developed by the Electronics Industry Association (EIA) that specifies what signals and voltages will be used to transmit data from DTE (computer) to DCE (modem).
Slave Expander Bus	Parallel address/data bus between the master module and the slave.
XR	Exception Report - A function block that reports a monitored point value when that value changes and is polled by a communication or master module.

REFERENCE DOCUMENTS

The following documents provide additional information about INPPR01 support hardware and software. Please refer to them as needed.

Document Number	Document
I-E96-309	Digital Slave Module (IMDSM05)
I-E96-310	Digital Slave Output Module (IMDSO01/02/03)
I-E96-313	Digital Slave Output Module (IMDSO04)
I-E93-905-2	Enhanced CIU Programmer's Reference Manual
I-E93-900-20	Function Code Application Manual
I-E96-611	Loop Interface/Bus Interface Module (INLIM03/INBIM02)
I-E96-110	Operator Interface Station
I-E96-620	Plant Loop to Computer Interface (INPCI01)
I-E96-621	Plant Loop to Computer Interface (INPCI02)
I-E93-900-5	Site, Planning and Equipment Installation
I-E93-911	Termination Unit Manual

NOMENCLATURE

Hardware	Nomenclature
Field Termination Panel	NFTP01
Module Mounting Unit	IEMMU01/02
Multi-Function Controller Termination Module Redundant Termination Module Cable	NIMF01 NIMF02 NKTM01
Multi-Function Controller Termination Unit Cable	NTMF01 NKTU01
Communication Termination Module Cable	NICL01 NKLS04
Communication Termination Unit Cable	NTCL01 NKLS03
Termination Mounting Unit	NTMU01/02

SPECIFICATIONS

Memory	
PPT	256 kbytes UVROM 512 kbytes RAM 80 kbytes NVM (non-volatile memory)
LIM	2 kbytes RAM 4 kbytes ROM
BTM	32 kbytes RAM 16 kbytes ROM
I/O Ports	2 RS-232C serial ports
Communication Rates	50 to 19,200 baud (user selectable)
Power Requirements	
PPT	6 amps @ +5 VDC; 30 watts 37 mA @ +15 VDC; 0.55 watts 18 mA @ -15 VDC; 0.27 watts
LIM	+5 VDC @ 2.0 amps; 10 watts nominal ±15 VDC @ 80 mA; 1.2 watts nominal
BTM	+5 VDC @ 1.0 amps; 5 watts nominal +15 VDC @ 150 mA; 2.25 watts nominal -15 VDC @ 120 mA; 1.80 watts nominal
Environmental	
Electromagnetic/Radio Frequency Interference	Values are not available at this time. Keep cabinet doors closed. Do not use communication equipment any closer than two meters from the cabinet.
Ambient Temperature	0° to 70°C (32° to 158°F)
Relative Humidity	0 to 95% up to 55°C (131°F) (non-condensing) 0 to 45% at 70°C (158°F) (non-condensing)
Altitude	Sea level to 3 Km (1.86 miles)
Air Quality	Noncorrosive
Certification	All INPPR01 modules have been individually CSA certified for use as process control equipment in an ordinary (nonhazardous) environment.

Specifications Subject To Change Without Notice

SECTION 2 - DESCRIPTION AND OPERATION

INTRODUCTION

This section explains the operation of the Plant Loop to Plant Loop Remote Interface.

LOCAL/REMOTE COMMUNICATIONS

Local and remote PPTs communicate with each other through a series of commands and replies over the serial ports. In the one-way mode, the local PPT issues commands only; in two-way, both the local and remote PPTs issue commands. The command format is:

1	2	3	4	5
Loop Number	Message Byte Count	Command Code	Command Data	Checksum or CRC

where:

1. Loop number is the loop that responds to the command (1 byte field).
2. Message byte count is the total length of the message (2 byte field).
3. Command code is the command code the PPT processes (1 byte field).
4. Command data is the specific command (variable length field).
5. Checksum is the sum of all the bytes in the command (1 byte field) or CRC, the cyclic redundancy check word computed for all of the bytes in the command using the CRC-16 algorithm (2 byte field).

All communications between interfaces use this format. INPPR01 commands are a modified form of Plant Loop to Computer Interface commands (refer to I-E93-905-9 for command details). The PPT format eliminates the key field from the PCI command. In addition to PCI commands, the PPT processes a command (code 29) that permits passage of a required PPT message.

DATA INTEGRITY

Verification of data integrity consists of even parity checking and the checksum in each command and reply format. The interface retries a transaction whenever it detects a communication error.

There are two levels of communication breakdown detection. The first level detects a complete failure of the communication link. Should this occur, Function Code 130 output block one will be set (logic one) and the alarm status bit set if port 1 fails. If port 0 fails, the output of block two will be set (logic one) and the alarm status bit set.

The second level of communication failure concerns the loss of a single remote interface. If this occurs, all blocks coming from that remote interface are bad quality. The PPR makes use of a user-configurable watchdog timer or absolute retry count in determining the sensitivity to these failures (refer to I-E93-200-20 for information about Function Code 130, S10 and S12).

TIMING INTERVAL

The local interface attempts communication twice a second with all the remote interfaces. Each successful transaction resets the communication watchdog timer. Therefore, if the communication link is faulty, no transactions occur successfully. After the watchdog time period expires, the link is marked bad.

For all communication transactions, the watchdog timer is reset on the reception of each character. If the time interval between characters in a transaction exceeds 1.25 seconds, the transaction is flushed and the remote interface is marked as being suspect. This condition causes retry logic to begin. Retry logic consists of retrying communication once per second for a number of times equal to one-fourth the watchdog time period if the absolute retry count is set to zero. A non-zero absolute retry count causes a specific number of retries (the number of the retry count). If the failure persists after the retry period expires, the remote interface is internally marked off-line and the quality of all the points it provides are marked bad.

Thereafter, a single retry of the failed remote interface occurs at a period equal to one half the watchdog timer period until a successful transaction occurs. The local interface sets the quality of all the points to their original state (before the communication failure). It also does a one time poll of the current value of each point.

A user-configurable time delay envelopes each command/reply sequence. This time delay accommodates the keying up/down

of modems and transmission equipment. The interface coordinates this activity through the RTS (Request-To-Send) signal of the RS-232-C port for modems or through digital outputs when using Digital Slave Modules (IMDSM05, IMDSO01/02/03/04) to enable other transmission equipment.

Transmit/Receive Timing

The user can set up the RS-232-C ports to operate as Data Circuit-Terminating Equipment (DCE) or Data Terminal Equipment (DTE). In the DCE mode, the Request-To-Send (RTS) line is always asserted. In the DTE mode, the RTS line is asserted before data transmission and inhibited after data transmission occurs.

The following events occur (see Figure 2-1) on port 0 when transmitting a command:

1. Assert RTS on the RS-232-C port (DTE mode) or set digital outputs 1 and 4 on the digital slave module.
2. A delay occurs between the time the port 0 asserts the RTS (or the digital outputs are set) and the command transmission occurs. Function Code 130 (S5) sets this delay (in milliseconds).
3. Output 4 is reset.
4. A delay occurs between the time output 4 is reset and output 1 is reset. Function Code 130 (S6) sets the length of this delay.
5. Output 1 is reset and RS-232-C RTS signal is inhibited (DTE mode).
6. A delay set by S5 of Function Code 130 occur between the output 1 reset and the reception of the reply.
7. The remote target issues a reply.

The following events occur (see Figure 2-1) when Port 0 receives a command:

1. The port receives the command.
2. A time delay set by S6 of Function Code 130 occurs.
3. The RS-232-C asserts the RTS signal (DTE mode) or set outputs 1 and 4 on the digital slave modules.
4. A time delay set by S5 of Function Code 130 occurs.

5. The remote interface transmits a reply to the interface sending the command.
6. Output 4 is reset.
7. A time delay set by S6 of Function Code 130 occurs.
8. Output 1 resets, RS-232-C RTS signal is inhibited (DTE mode).

NOTE: RTS assert and inhibit apply to DTE mode only. RTS is always asserted for DCE mode.

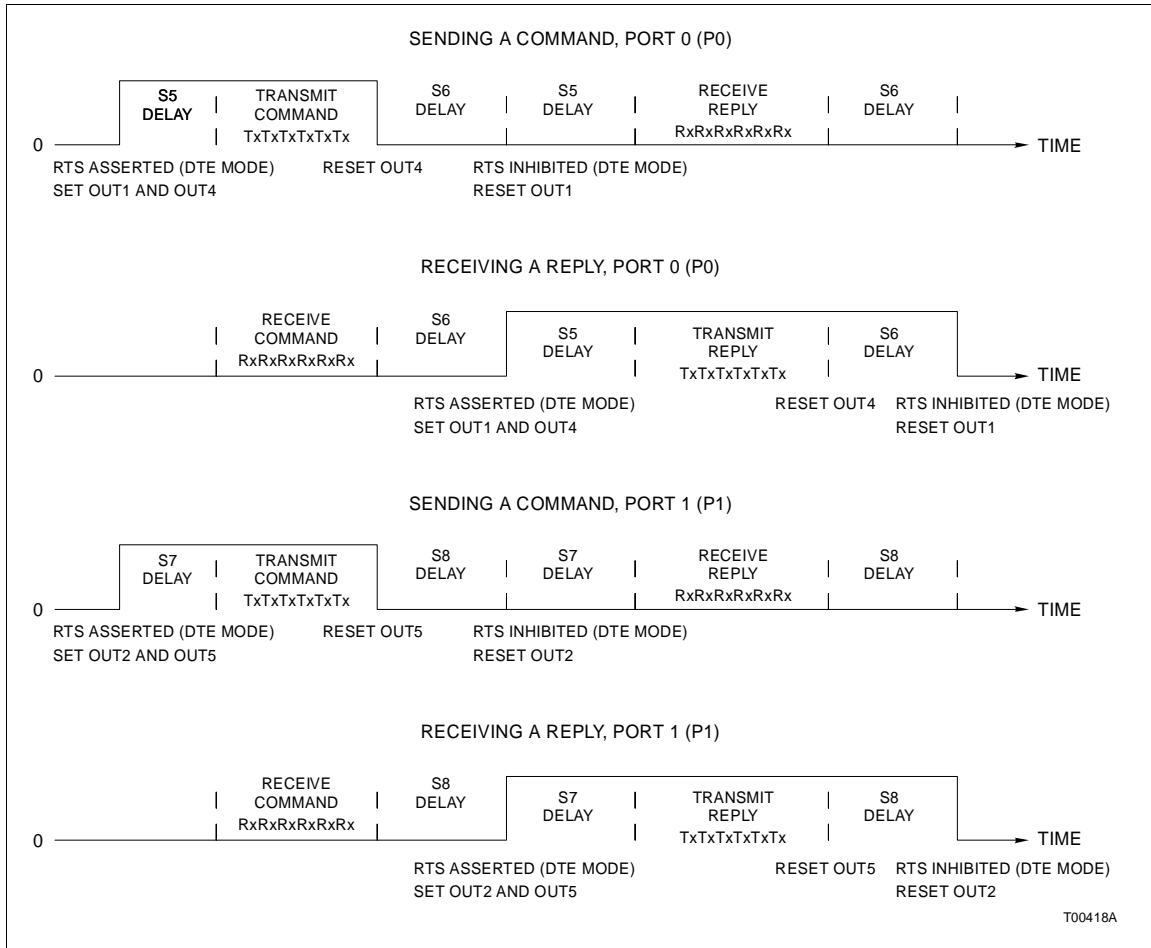

Figure 2-1. Send/Receive Timing Diagram

SECTION 3 - INSTALLATION

INTRODUCTION

This section explains special handling procedures, switch settings for each interface module, and how to install related hardware. Complete the preliminary procedures in this section before placing the INPPR01 into operation.

SPECIAL HANDLING

Plant Loop to Plant Loop Interface modules use Electrostatic Sensitive (ESD) devices. Follow these handling procedures:

NOTE: Always use the Bailey Field Static Kit (P/N 1948385A1) when working with interface modules. This kit connects the static dissipative work surface and technician to the same ground point.

1. Keep the modules in their special anti-static bags until you are ready to install them in the system. Save the bags for future use.
2. Ground the anti-static bag before opening.
3. Verify that all devices connected to the modules are properly grounded before using them.
4. Avoid touching the circuitry when handling the module.

UNPACKING AND INSPECTION

1. Examine the PPT, LIM and BTM immediately to verify that they have not been damaged in transit.
2. Notify the nearest Bailey Controls Sales Office of any such damage.
3. File a claim for any damage with the transportation company that handled the shipment.
4. Use the original packing material and/or container to store the modules.
5. Store the module in an environment of good air quality and free from temperature and moisture extremes.

INPPT01 SWITCH SETTINGS

The INPPT01 consists of two circuit boards, a memory board and a CPU board. The memory board has no user-configurable

operating options. The CPU board has three dipswitches that set the module operating characteristics. These switches provide the means of establishing the type of control, serial port communication rate, and loop address. Figure 3-1 shows the dipswitch locations on the CPU board.

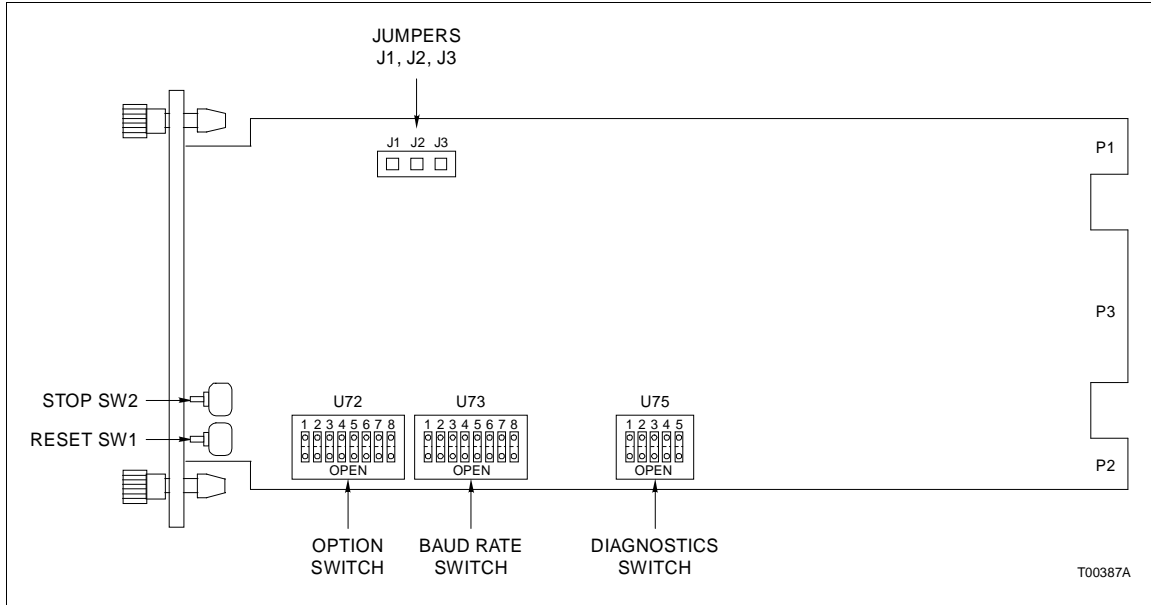

Figure 3-1. Switch Locations on the PPT (CPU board)

Option Switch (U72)

U72 is an eight position dipswitch that determines the operating options of the module. Table 3-1 lists the U72 option settings. Record the U72 settings in the space provided. When setting switches, 0 = Closed (on) and 1 = Open (off).

Table 3-1. Option Switch (U72) Settings

Position	Setting	Function	User Setting
1	0	ROM checksumming enabled	
	1	ROM checksumming disabled	
2	0	RS-232-C port in DCE mode (direct connections)	
	1	RS-232-C port in DTE mode (modem connections)	
3	0	Equipment select output de-energized	
	1	Equipment select output energized ¹	
4	0	Port 1 option interface communication	
	1	Port 1 utility option ²	
5	0	Interface ID local ³	
	1	Interface ID remote	
6	0	Interface mode two-way control ⁴	
	1	Interface mode one-way control	

Table 3-1. Option Switch (U72) Settings (continued)

Position	Setting	Function	User Setting
7	0 1	Don not initialize NVM Initialize NVM	
8	0 1	Primary/Secondary (one module of redundant pair is set to 0, the other module is set to 1)	

NOTES: 0 = Closed (on), 1 = Open (off)

1. A unique equipment select output can exist between the primary and secondary PPT. The equipment select output is digital output three of a digital slave (IMDSM05 or IMDSO01/02/03/04).
2. Port 1 responds as DCE when it is configured as a utility port. Set switch position 4 = 1 if port 1 is not used as a communication interface.
3. Define only one interface as a local interface (position 5).
4. The following conditions apply when using two-way control (position 6 = 0):
 - a. The port 1 option defaults to interface communication (position 4 = 0).
 - b. The local INPPR01 uses port 0 as its command port and port 1 as its reply port.
 - c. The remote INPPR01 uses port 1 as its command port and port 0 as its reply port.
 - d. Both the local and remote interface must have a loop address of 0 (U75).

Serial Port Communication Rate (U73)

U73 is an eight pole dipswitch that sets the serial port communication rate. The communication rate directly affects data throughput. Refer to Table 3-2 for communication rates. Table 3-3 lists message throughput for different point types. Record the U73 setting in the space provided.

Table 3-2. Serial Port Communication Rate (U73)

Switch Position								Baud Rate	User Setting							
Port 0				Port 1					Port 0				Port 1			
1	2	3	4	5	6	7	8		1	2	3	4	5	6	7	8
0	0	0	0	0	0	0	0	50								
1	0	0	0	1	0	0	0	75								
0	1	0	0	0	1	0	0	110								
1	1	0	0	1	1	0	0	134.5								
0	0	1	0	0	0	1	0	150								
1	0	1	0	1	0	1	0	300								
0	1	1	0	0	1	1	0	600								
1	1	1	0	1	1	1	0	1200								
0	0	0	1	0	0	0	1	1800								
1	0	0	1	1	0	0	1	2000								
0	1	0	1	0	1	0	1	2400								
1	1	0	1	1	1	0	1	3600								
0	0	1	1	0	0	1	1	4800								
1	0	1	1	1	0	1	1	7200								
0	1	1	1	0	1	1	1	9600								
1	1	1	1	1	1	1	1	19200								

NOTE: 0 = Closed (on), 1 = Open (off)

Table 3-3. Message Throughput

Point Type	Number of Bytes	Time per Point ¹	Points per Second
Station	19	10.4 msec	96
Analog	8	4.7 msec	214
Digital	5	3.1 msec	322
Remote Control Memory (RCM)	7	4.1 msec	241
Remote Manual Set Constant (RMSC)	7	4.1 msec	241
Device Driver	7	4.1 msec	241

1. These figures are based on the calculated throughput of the various Exception Report data types (at 19200 baud). Regardless of communication rate, the software overhead is approximately 0.5 millisecond per point.

Loop Address (U75)

Dipswitch U75 sets the loop address. Valid addresses are 0 through 31. Table 3-4 shows examples of switch settings for the loop address. Record the loop address in the space provided.

Table 3-4. U75 Loop Addresses

Example Settings						
Address Example	Switch Position	1	2	3	4	5
	Binary Value	16	8	4	2	1
0		0	0	0	0	0
9		0	1	0	0	1
26		1	1	0	1	0

User Setting						
User Address	Switch Position	1	2	3	4	5
	Binary Value	16	8	4	2	1

NOTE: 0 = Closed (on), 1 = Open (off)

INLIM03 SWITCH SETTINGS

The Loop Interface Module (INLIM03), shown in Figure 3-2, has two user-configurable dipswitches: Event/Error Counter Address Switch SW1 and Address Switch SW2. Tables 3-5 and 3-6 list the switch settings for the Event and Error Counters. The LIM faceplate LEDs display the contents of the event/error counters. Switch SW2 poles 1 and 2 are CLOSED for normal operation. Refer to Table 3-7 for SW2 settings. The LIM can have any address from 1 to 63.

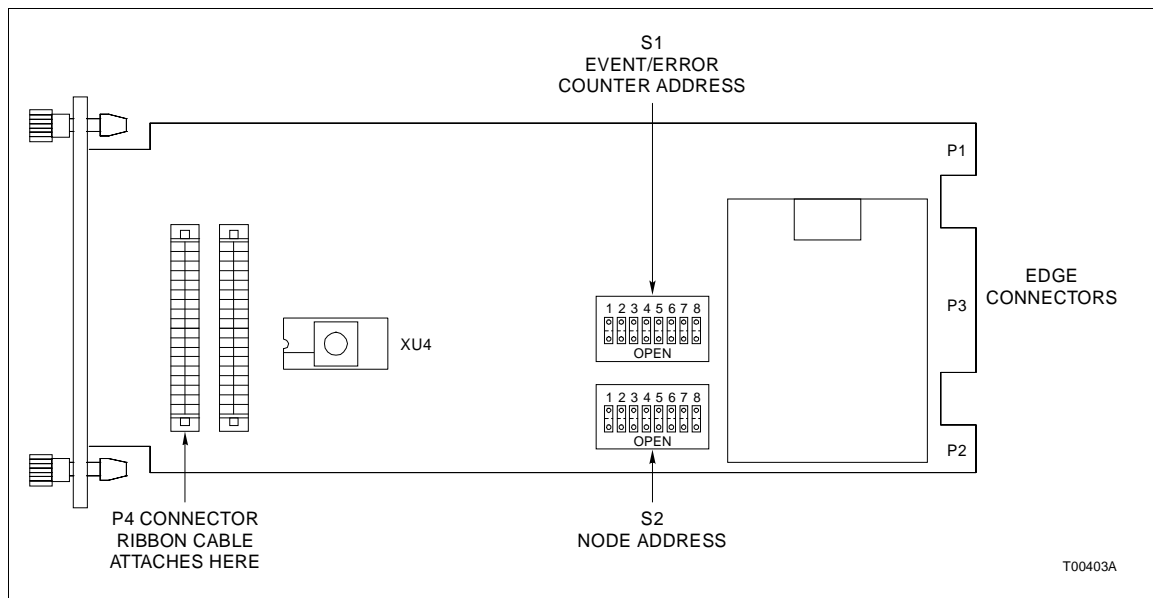

Figure 3-2. LIM Switch Locations

Table 3-5. LIM Event Counter Addresses (SW1)

Counter Address	Hex Address	Switch Position 1 2 3 4 5 6 7 8	Description	User Setting
48	30	0 0 1 1 0 0 0 0	Total messages transmitted, including forwarding.	
49	31	0 0 1 1 0 0 0 1	Transmit retries.	
50	32	0 0 1 1 0 0 1 0	Composite BTM Receive/Transmit, 4 bits each. Receive is viewed at the top LED.	
51	33	0 0 1 1 0 0 1 1	Messages taken from the BTM transmit buffer.	
52	34	0 0 1 1 0 1 0 0	Messages stored in BTM receive buffer.	
53	35	0 0 1 1 0 1 0 1	Interrupt Requests (IRQs) sent by BTM.	
54	36	0 0 1 1 0 1 1 0	High Priority (HP) messages transmitted.	
55	37	0 0 1 1 0 1 1 1	High Priority messages received.	
56	38	0 0 1 1 1 0 0 0	Commands issued by the BTM.	
57	39	0 0 1 1 1 0 0 1	Missed BTM transmit requests.	

Table 3-5. LIM Event Counter Addresses (SW1) (continued)

Counter Address	Hex Address	Switch Position 1 2 3 4 5 6 7 8	Description	User Setting
58	3A	0 0 1 1 1 0 1 0	Spurious Non-Maskable Interrupts (NMI) caused by address present.	
59	3B	0 0 1 1 1 0 1 1	HEY (request for an interrupt; generated by BTM) message sent.	
60	3C	0 0 1 1 1 1 0 0	Messages discarded when the destination is off-line.	
61	3D	0 0 1 1 1 1 0 1	HEY time expirations.	
62	3E	0 0 1 1 1 1 1 0	Passes through the IDLE level (2 bytes wide).	

NOTE: 0 = Closed (on), 1 = Open (off)

Table 3-6. LIM Error Counter Addresses (SW1)

Counter Address	Hex Address	Switch Position 1 2 3 4 5 6 7 8	Description	User Setting
64	40	0 1 0 0 0 0 0 0	Composite error count developed every handshake period - the summation of all other error counters.	
65	41	0 1 0 0 0 0 0 1	Unresolved NMI interrupts.	
66	42	0 1 0 0 0 0 1 0	Unresolved IRQ interrupts.	
67	43	0 1 0 0 0 0 1 1	Unresolved timer interrupts.	
68	44	0 1 0 0 0 1 0 0	Unused.	
69	45	0 1 0 0 0 1 0 1	Queue overflows.	
70	46	0 1 0 0 0 1 1 0	Unresolved BTM IRQs.	
71	47	0 1 0 0 0 1 1 1	Sequence errors.	
72	48	0 1 0 0 1 0 0 0	Header CRC/OVRN errors.	
73	49	0 1 0 0 1 0 0 1	Data CRC/OVRN errors.	
74	4A	0 1 0 0 1 0 1 0	Messages developing data CRC errors on route to destination.	
75	4B	0 1 0 0 1 0 1 1	Transmission failures.	
76	4C	0 1 0 0 1 1 0 0	Watchdog timer expirations.	
77	4D	0 1 0 0 1 1 0 1	Data length errors.	
78	4E	0 1 0 0 1 1 1 0	Loop - 1 Receive (RCV) failure.	
79	4F	0 1 0 0 1 1 1 1	Loop - 2 Receive failures.	
80	50	0 1 0 1 0 0 0 0	Loop - 1 Transmit (TX) failure.	
81	51	0 1 0 1 0 0 0 1	Loop - 2 Transmit failures.	

NOTE: 0 = Closed (on), 1 = Open (off)

Table 3-7. LIM Node Address Setting (SW2)

		Example Settings							
Address Example	Switch Position	1	2	3	4	5	6	7	8
	Binary Value	128	64	32	16	8	4	2	1
1		0	0	0	0	0	0	0	1
9		0	0	0	0	1	0	0	1
63		0	0	1	1	1	1	1	1

		User Setting							
User Address	Switch Position	1	2	3	4	5	6	7	8
	Binary Value	128	64	32	16	8	4	2	1

NOTE: 0 = Closed (on), 1 = Open (off)

INBTM01 SWITCH SETTINGS

The Bus Transfer Module (INBTM01), shown in Figure 3-3, has one user-configured dipswitch (SW1). SW1 enables module diagnostics. Refer to Table 3-8 and set SW1 for normal operation.

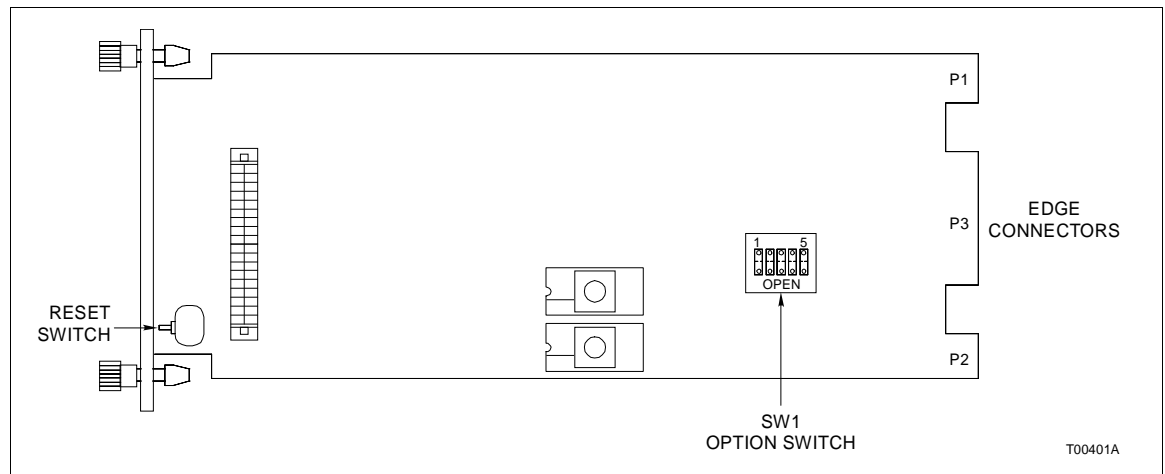

Figure 3-3. BTM Switch (SW1) Location

Table 3-8. BTM Options (SW1)

Switch Position 1 2 3 4 5	Function	User Setting
0 0 0 0 0	Normal operation.	
0 0 0 1 0	Normal BTM operation without catastrophic error checking (for Test Purposes ONLY).	
0 0 1 0 0	RAM test mode. If Status LED turns red, the module has failed the test.	
0 0 1 1 0	ROM test mode. If Status LED turns red, the module has failed the test.	
0 1 0 0 0	Execute Interrupt Request (IRQ) LIM handshake diagnostic. Used in combination with the LIM off-line diagnostics.	

NOTE: 0 = Closed (on), 1 = Open (off)

TERMINATION UNIT (MODULE) CONFIGURATION

Two of the interface modules (INLIM03, INPPT01) require termination. The INPPT01 terminates with the NTMF01 or NIMF01/NIMF02. The INLIM03 terminates with the NTCL01 or NICL01. Appendices A through D contain dipshunt configuration information. Figure 3-4 shows a diagram of the NTMF01 and NTCL01 in a redundant installation. Figure 3-5 shows a diagram of the NIMF01/NIMF02 and NICL01 in a redundant installation.

NTMF01/NIMF01/NIMF02 Configuration

The TMF and IMF provide the INPPT01 with two RS-232-C ports. Configure these ports to operate as DTE, DCE or diagnostic terminal. Refer to Figures A-1, A-2, and A-3 for NTMF01 dipshunt configurations. Refer to Figures C-1, C-2, and C-3 for NIMF01/NIMF02 dipshunt configurations.

NOTE: You must use the NIMF01 and NIMF02 when using termination modules to terminate a redundant interface. Non-redundant interfaces need only the NIMF01.

ONE-WAY CONTROL

Configure port 0 on the local and remote interfaces to act as DTE. One local INPPR01 can communicate with up to 32 remote interfaces in the one-way control mode. Additional communication equipment such as a modem network, radio link or microwave link is required when interfacing multiple remotes. The user supplies any additional equipment that is needed.

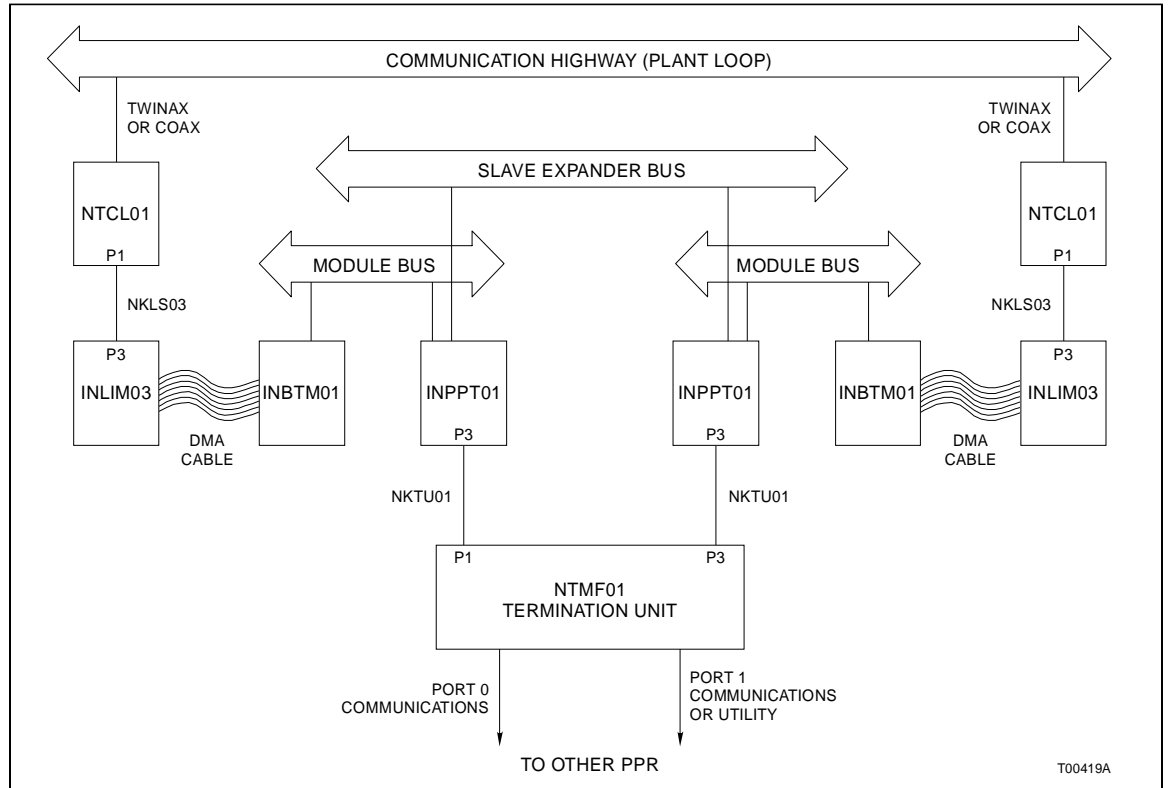

Figure 3-4. NTMF01 and NTCL01 in a Redundant Installation

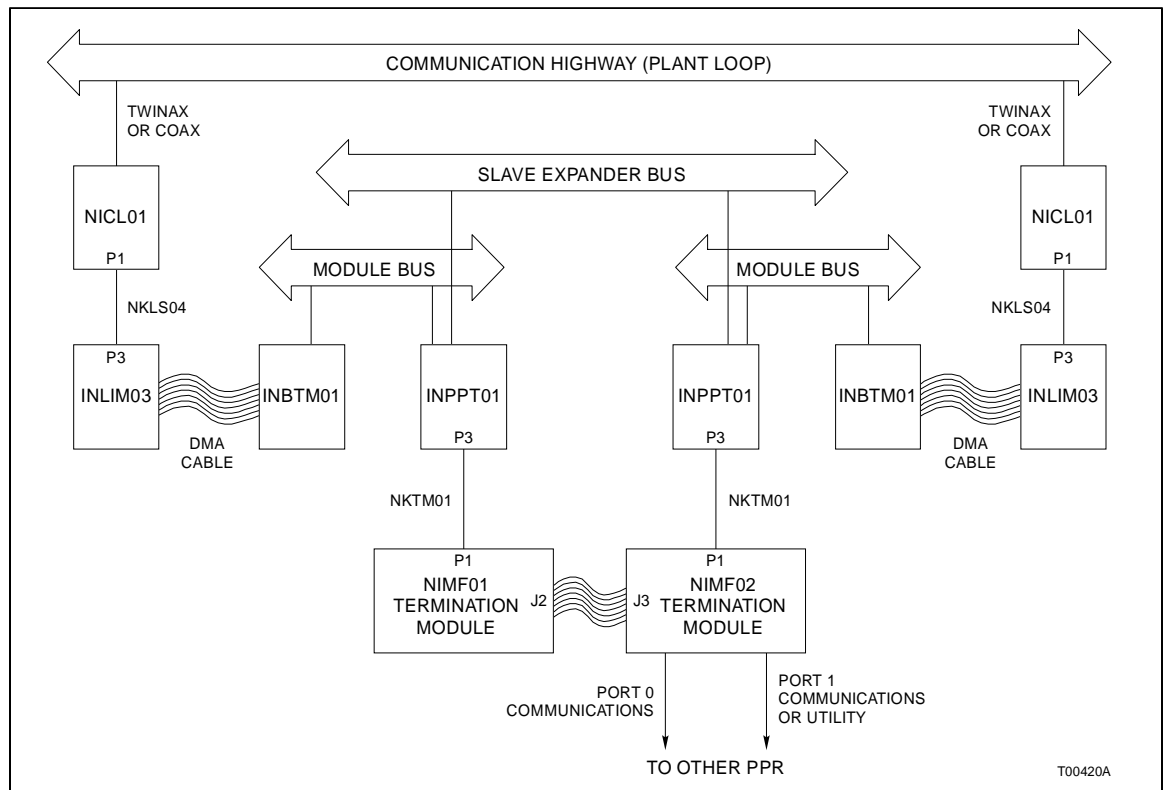

Figure 3-5. NIMF01/NIMF02 and NICL01 in a Redundant Installation

When directly connecting only one remote interface in one-way control, set port 0 on the local interface to act as a DTE. Set port 0 on the remote interface to act as DCE.

NOTE: Always configure port 1 as a utility port if it is not used as an interface communication port. The PPT option switch (U72) position 4 must be set to 0 (utility option). Port 1 will always act as a DCE in this configuration.

TWO-WAY CONTROL

The interface requires both serial communication ports in the two-way control mode. Connect port 0 of the local Plant Loop to port 0 of the remote Plant Loop. Connect port 1 of local Plant Loop to port 1 of the remote Plant Loop.

Configure the termination unit to act as DTE to enable the Plant Loop to Plant Loop Transfer Module to communicate with DCE (i.e., a modem). Configure the termination unit to act as DCE to enable the PPT to communicate with DTE (i.e., a terminal). Figure A-4 shows how the termination dipshunt configuration directs the RS-232-C signals.

NTCL01/NICL01 Configuration

The TCL and ICL provide the INLIM03 with Plant Loop termination. The user has the option of using Twinax or Coax cable to connect the interface to the Plant Loop. Tables B-3 (NTCL01) and D-3 (NICL01) show the jumper settings for twinax and coax cables. Set the jumpers accordingly for your application.

NOTE: For complete cable and TU/TM installation information, refer to the *Termination Unit Manual (I-E93-911)*.

INSTALLING THE INTERFACE MODULES

If the switch settings on the interface modules are complete, they are ready to be installed in the Module Mounting Unit (MMU).

Installing the INPPT01

WARNING

Disconnect power before installing dipshunts for slave modules on the MMU backplane (slave expander bus). Failure to do so could result in severe or fatal shock.

AVERTISSEMENT

Couper l'alimentation avant d'installer les dipshunts sur la plaque arriere du chassis de montage de modules (MMU). Toute negligence a cet egard constitue un risque de choc pouvant entrainer des blessures graves, voire morelles.

To install the PPT:

1. Verify the PPT slot assignment in the MMU.
 - a. If you are installing redundant PPTs, install a 24 pin disphunt in the Slave Expander Bus socket between the slot used by the primary PPT and the slot used by the secondary PPT. Both PPTs must reside on the same Slave Expander Bus.
 - b. Each PPT must reside on its own module bus.
2. Attach the hooded end of the cable (NTKU01 for the NTFM01; NKTM01 for the NIMF01 and NIMF02) to the MMU backplane cable connector opening for the PPT. The other end of the cable attaches to the termination unit or backplane of the Termination Mounting Unit (NTMU01).
3. Guide the top and bottom edges of the circuit card along the top and bottom rails of MMU.
4. Slide the module into the slot; push the module until the front panel is flush with the top and bottom of the MMU frame.
5. Turn the two captive latches a half turn to lock the module in place.

Installing the INLIM03 and INBTM01

The LIM and BTM should be installed as a pair in adjacent slots. To install the LIM/BTM:

1. Verify the MMU slot assignments for the modules. If you are installing redundant LIM/BTM pairs, each BTM must be installed on the module bus that belongs to its related PPT.
2. Attach the hooded end of the cable (NKLS03 for NTCL01; NKLS04 for the NICL01) to the MMU backplane cable connector opening for the LIM. The other end of the cable attaches to the termination unit or TMU backplane.
3. Connect one end of the Bailey supplied ribbon cable (DMA cable) to the P4 connector on the LIM. Connect the other end of the DMA cable to the P4 connector on the BTM (see Figures 3-2 and 3-3).
4. Guide the top and bottom edges of both circuit cards along the top and bottom rails of adjacent slots in the MMU.
5. Slide the modules into the slot; push the module until the front panels are flush with the top and bottom of the MMU frame.

6. Turn the two captive latches a half turn to lock the module in place.

INSTALLING A REDUNDANT INTERFACE

Installing a redundant interface requires an additional set of INPPT01, INLIM03 and INBTM01 modules. Both PPT modules must be on the same Slave Expander Bus, but reside on separate Module Bus. Each PPT has a pair of LIM/BTM modules on a dedicated Module Bus.

Observe the following conditions when installing a redundant interface:

1. U72 position 8 must be set to 0 on the primary PPT.
2. U72 position 8 must be set to 1 on the secondary PPT.
3. SW1 all positions must be set to 0 on both BTMs.
4. The slave expander bus of two adjacent MMUs (one on top of the other) are connected with the expander bus extender cable (Bailey P/N 1958502A0340).
5. The module bus between these MMUs are not connected.

Applications that use redundant communication equipment may require additional hardware. Figure 3-6 shows a diagram of the interface using the IMDSM05 to enable redundant transceivers. Function Code 130 provides the software the PPT needs to enable the transceivers. Voltage levels and polarities of enable signals to transceivers and other communication equipment may vary. Refer to the applicable user manual when connecting this equipment to the IMDSM05, IMDSO01/02/03/04 Digital Slave Module.

INTERFACE CONFIGURATION

The user must configure the PPT with the proper function codes before it can be placed into service. The PPT configuration determines interface operating characteristics such as time synchronization, serial communication rate, node definition, point definitions and general execution characteristics.

Table 3-9 lists the function codes used by the INPPR01. Refer to the **Function Code Application Manual (I-E93-900-20)** for information about the function codes in Table 3-9.

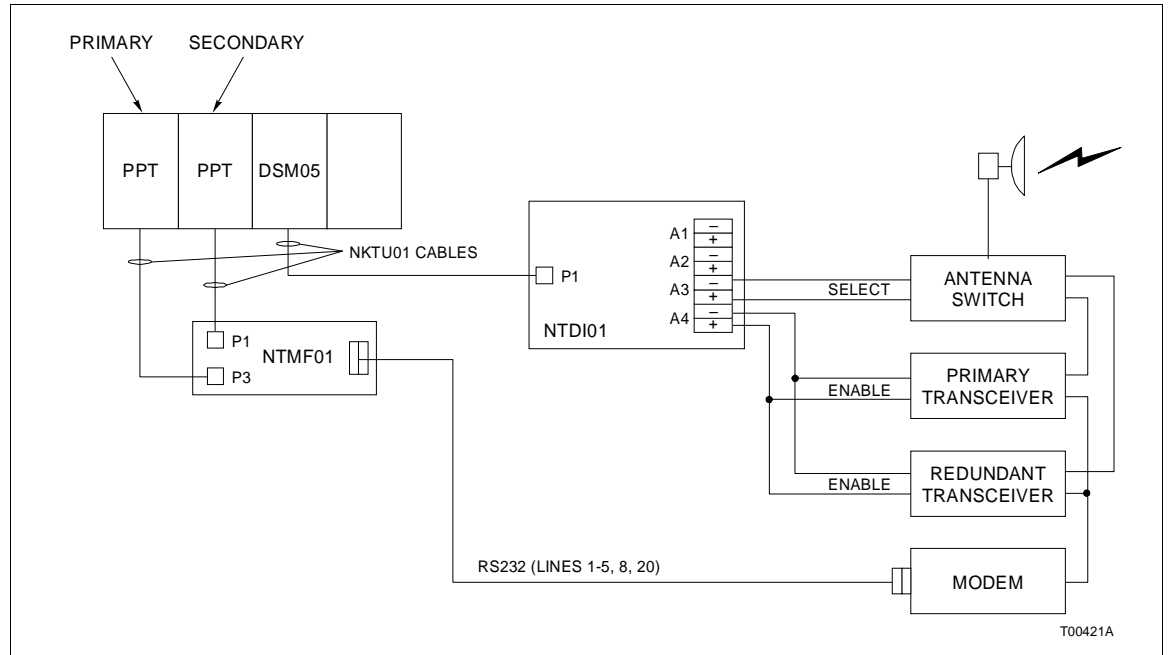

Figure 3-6. Redundant Transceiver

Table 3-9. INPPR01 Function Codes

Function Code	Title
FC 127	Plant Loop Gateway Node Map
FC 130	Plant Loop Gateway Executive
FC 131	Plant Loop Gateway Point Definition

SECTION 4 - OPERATING PROCEDURES

INTRODUCTION

This section explains how to place the INPPRO1 in operation. It covers faceplate LEDs, modes of operation, and the two control types. Additionally, it provides information concerning redundant operation and interface memory utilization.

PLANT LOOP TO PLANT LOOP TRANSFER MODULE LEDs AND CONTROLS

The faceplate of the PPT has the following components (see Figure 4-1):

1. Status LED
2. 8 CPU LEDs
3. 2 Memory Status LEDs
4. Stop pushbutton
5. Reset pushbutton

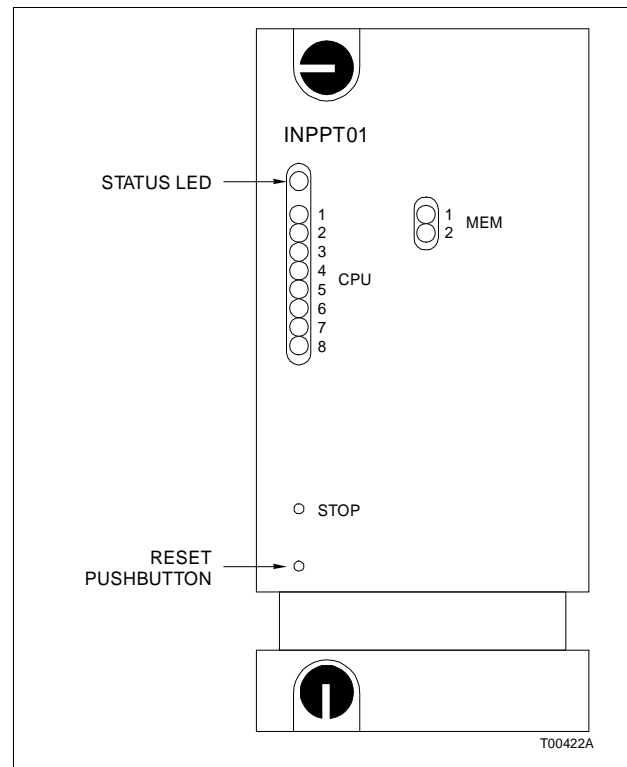

Figure 4-1. PPT Faceplate LEDs

Status LED

The Status LED is a red/green LED that displays the operating status of the PPT. It has five possible states. Table 4-1 lists the meaning of the status LED states. Refer to Section 5 for corrective action if the status LED indicates that an operating error exists.

Table 4-1. PPT Status LED States

LED State	Meaning
Off	No power to the PPT.
Solid Green	The PPT is in the EXECUTE Mode.
Flashing Green (once per second)	The PPT is in the EXECUTE Mode and detects a NVM checksum error.
Flashing Green (4 times per second)	The PPT is in the CONFIGURE or ERROR Mode.
Solid Red	The PPT diagnostics detect a hardware failure or configuration problem. CPU LEDs display an error code when the status LED is red.

CPU LEDs

During normal operation, the CPU LEDs keep a count of the internal and external messages that pass through the PPT. If a communication error occurs, these LEDs display an error code and the Status LED turns RED. Refer to Table 5-1 for a list of CPU LED error codes and corrective action.

Memory LEDs

There are two Memory LEDs. MEM LED 2 is on while the module is correcting single bit errors. Both LEDs are on when a two-bit error or a complete memory failure occurs.

Stop Pushbutton

Push the stop pushbutton before removing a PPT from the Module Mounting Unit. The stop pushbutton causes the following actions to occur:

1. Allows any NVM write in progress to complete.
2. Forces control from a primary to a secondary PPT in redundant configurations.

Reset Pushbutton

Pressing the reset pushbutton causes:

1. Restoration of PPT to power-up values after a halt.

2. Recovery from an operator-initiated stop or a module timeout.

LOOP INTERFACE MODULE LEDs

There are eight LEDs on the LIM faceplate (see Figure 4-2). These LEDs display the contents of event and error counters, and pass/fail information when on-board diagnostics are run (refer to Tables 3-4 and 3-5 for a list of event and error counter codes).

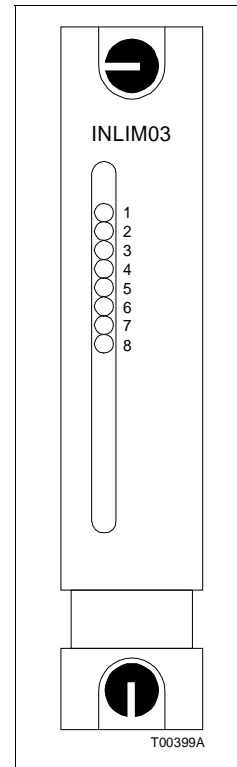

Figure 4-2. LIM Faceplate LEDs

BUS TRANSFER MODULE LED

The Bus Transfer Module has one red/green LED that displays the module's operating condition (see Figure 4-3). The BTM Status LED has three possible states. Refer to Table 4-2 for BTM Status LED states and their meaning. Section 5 explains the corrective action to take if the Status LED displays a BTM hardware failure.

MODES OF OPERATION

The Plant Loop-to-Plant Loop Remote Interface has three modes of operation: Configure, Execute and Error. Within the Execute mode the module has two methods of control: one-way or two-way control.

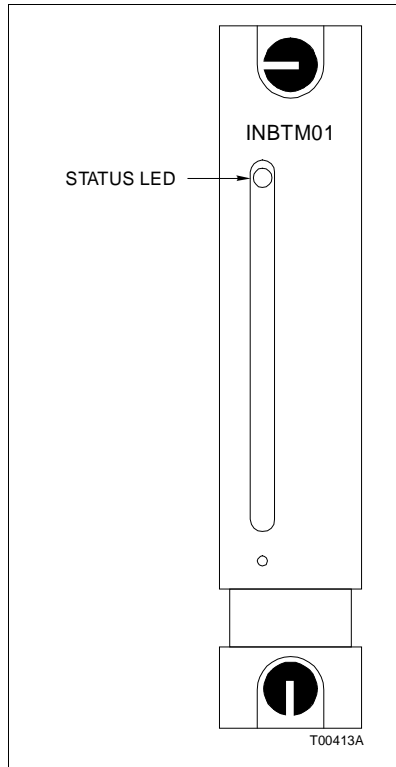

Figure 4-3. BTM Faceplate LEDs

Table 4-2. BTM Status LEDs States

LED States	Meaning
Off	No power to the BTM.
Solid Green	Normal Operation.
Solid Red	BTM hardware failure.

Configure Mode

This mode applies to the INPPT01 module. Module configuration requires an INF1 90 operator interface device (i.e., Operator Interface Station, Management Command System, Engineering Work Station, etc.). Refer to [Section 3](#) and to the instruction for your operator interface device for information about interface configuration.

Execute Mode

This is the normal mode of operation for the PPR. In the execute mode, the PPR issues requests for exception reports (XRs) twice a second, collects XRs, exercises control (local to remote), allows the operator to adjust tunable module specifications and configure modules in remote loops. The interface enters one of the two control types that the user configures during installation.

Error Mode

The PPT enters this mode if the built-in system diagnostics detect a hardware or configuration error. If the PPT detects a hardware error, the module halts and displays an error code on the CPU LEDs. If the CPU LEDs display a configuration error, the module remains in the error mode. Refer to [Section 5](#) for corrective action when the PPT enters the error mode.

One-Way Control

The PPT option switch setting (set during installation) determines if the module is in one-way control. In one-way control, the local Plant Loop requests XRs from all remotes twice a second. The operator does module tuning and configuration, and issues control commands to the remote Plant Loops through the operator interface.

This type of control requires only one serial port (port 0). Port 1 can also be used as an additional link through which the local loop issues commands. Using both ports increases the total throughput of the PPT (see [Figure 4-4](#)).

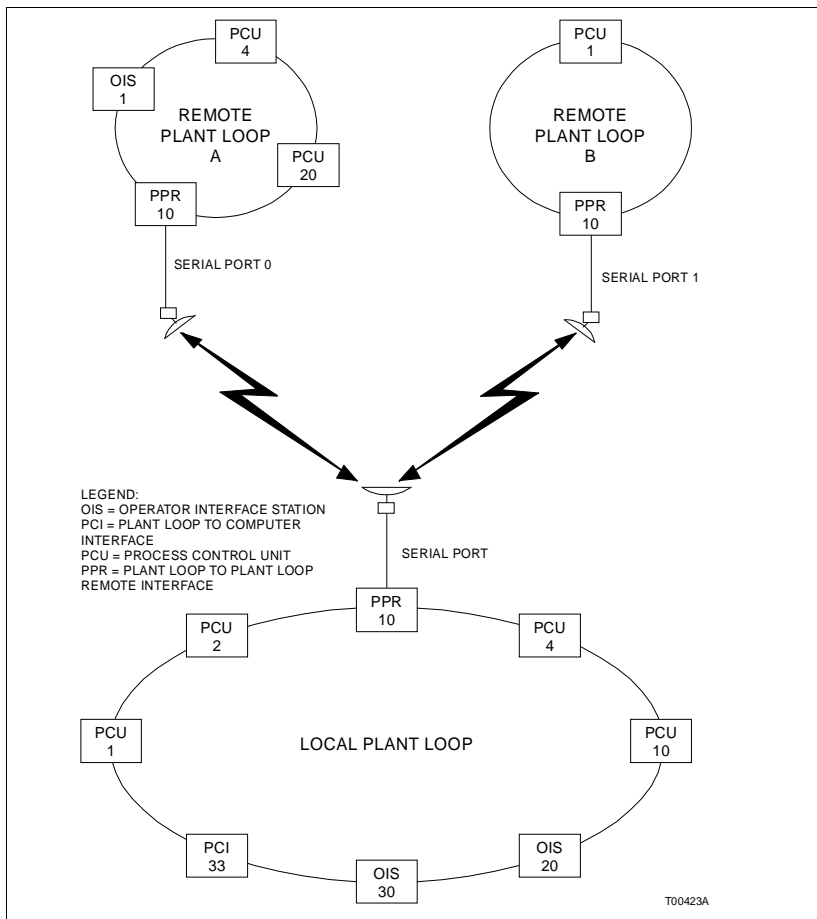

Figure 4-4. Local Plant Loop Using Both Serial Ports in One-Way Control

Two-Way Control

In two-way control, bidirectional communication requires both ports on both Plant Loops (Port 0 to Port 0; Port 1 to Port 1). Both loop interfaces can issue requests, control commands and do module tuning and configuration. The local interface uses one serial port to issue commands and receive replies (see Figure 4-5). The remote interface uses the other port for the same purpose. As in one-way control, the PPT requests XRs twice a second; control and configuration commands are through operator action.

REDUNDANT INTERFACE OPERATION

Redundant interface configurations require two sets of LIM/BTM and PPT modules. Each set of modules reside on a separate module bus. Redundant interfaces share a common slave expander bus. Upon start-up, one interface assumes the primary role; the other waits in a backup role. The primary PPT

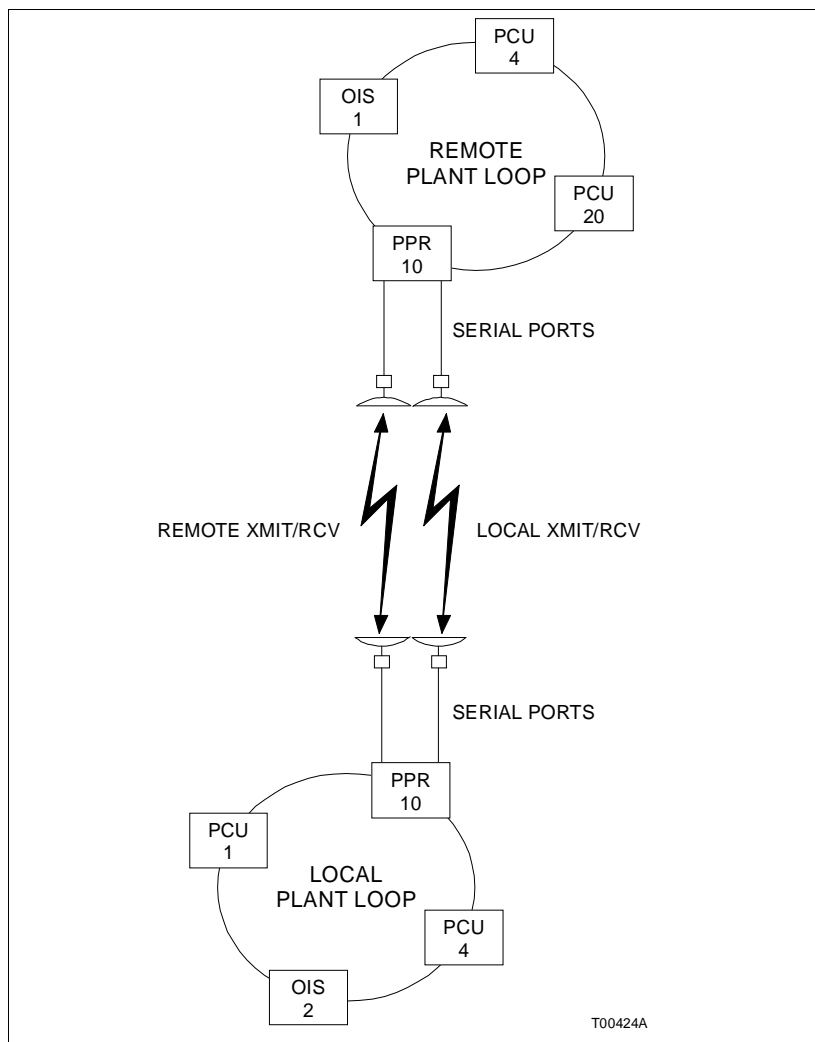

Figure 4-5. Local and Remote Plant Loops in Two-Way Control

downloads the interface configuration to the secondary (redundant modules are identically configured to their primary counterpart). If the primary interface fails, the redundant unit takes over and re-establishes the point data.

INTERFACE POINT CAPACITY

There are three factors that determine the maximum number of points in a PPT configuration. Those factors are: point type (exception report data type), the number of devices that receive interface generated exception reports and the total memory available (440,000 bytes). Table 4-3 lists the required memory bytes for all point types when memory usage is for:

1. The local PPT receiving points from the remote PPT.
2. The remote PPT (in two-way mode) receiving points from the local PPT.

Table 4-3. Memory Usage in Receiving Communication

Point Type	Memory Bytes Required
Digital	16
Analog	30
Station	76
Remote Control Memory (RCM)	22
Remote Manual Set Constant (RMSC)	38
Device Driver	22

NOTE: Add 6 bytes per point per destination being sent.

Table 4-4 lists the required memory bytes for all point types when the memory usage is for:

1. The remote PPT sending points to the local PPT.
2. The local PPT (in two-way mode) sending points to the remote PPT.

NOTE: The PPT has a capacity of 5,000 blocks.

Table 4-4. Memory Usage in Sending Communication

Point Type	Memory Bytes Required
Digital	18
Analog	22
Station	70
Remote Control Memory(RCM)	22
Remote Manual Set Constant (RMSC)	26
Device Driver	22

NOTE: Add 16 bytes for each PCU that sources Exception Reports. Add 10 bytes for each module that sources Exception Reports.

MEMORY USAGE EXAMPLE

In this example, a pair of interfaces in one-way mode has the following mix of points in their configuration:

500 digital points (S3 of FC131 = 0)
 200 analog points (S3 of FC131 = 1)
 50 stations (S3 of FC131 = 2)

Distribution of 750 total points on the remote loop is among 20 modules residing in 10 different PCUs. There are five OISs on the local loop. Each OIS receives all of the points.

Memory Usage in the Local PPT

The points are coming to the local from the remote, therefore, Table 4-3 applies. The calculations are:

500 digital points x 16 bytes/point = 8,000 bytes
 200 analog points x 30 bytes/point = 6,000 bytes
 50 station points x 76 bytes/point = 3,800 bytes

Each OIS receives all 750 points:
 5 OIS x 750 points x 6 bytes/point = 22,500 bytes
 Total memory used in the local PPT = 40,300 bytes

Memory Usage in the Remote PPT

These points are to be sent to the local, therefore, Table 4-4 applies. The calculations are:

500 digital points x 18 bytes/point = 9,000 bytes
 200 analog points x 22 bytes/point = 4,400 bytes
 50 station points x 70 bytes/point = 3,500 bytes
 20 modules x 10 bytes/module = 200 bytes
 10 PCUs x 16 bytes/PCU = 160 bytes
 Total memory used in the remote PPT = 17,260 bytes

SECURITY FUNCTIONS

The PPT performs both hardware and software security checks to insure module integrity.

Hardware Checks

The PPT does the following hardware checks:

1. Error Detection and Correction - Detects single bit and double bit errors in the dynamic RAM. Corrects single bit errors; halts PPT operation on double bit errors.
2. Illegal Address Detection - Detecting an illegal address generates a bus error and the PPT halts operation.
3. Machine Fault Timer - The microprocessor updates this timer. A machine fault timeout halts module operation.

Software Checks

The PPT does the following software checks:

1. Module Diagnostics - Module diagnostics execute automatically on system power up. PPT faceplate LEDs display error conditions if the diagnostic tests fail.
2. Module Status Check - This test verifies checksums of the UVROM and NVM. Discrepancies cause the PPT Status LED to flash green and PPT operation halts.

Utilities

The utilities menu shown in Figure 4-6 is available to the user by attaching a diagnostic monitor to serial port 1. Items 1, 4 and 5 are used for Bailey Engineering purposes. Items 2 and 3 are available to the user.

When **2** is keyed in, the following appears:

*2 - Which Loop?
reply: not configured or
communicating or
communication failed, will retry in x seconds*

When **3** is keyed in, the following appears:

*3 - Enter Slave Address:
enter new digital outputs:
reply 0 or 1*

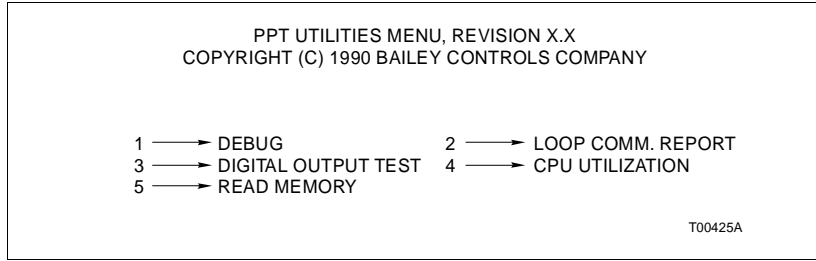

Figure 4-6. PPT Utilities Menu

SECTION 5 - TROUBLESHOOTING

INTRODUCTION

If errors occur while the interface is operating, the CPU LEDs on the PPT faceplate display error codes. Table 5-1 lists the error codes and corrective action.

NOTE: Codes are displayed only when the PPT is halted and the Status LED is red. A 0 represents a LED that is off and a 1 represents a LED that is on.

Table 5-1. Table 5-1. PPT Error Codes

LED 8 7 6 5 4 3 2 1	Meaning	Corrective Action
0 0 0 0 0 0 0 1	An error affecting the NVM checksum has occurred.	None.
0 0 0 0 0 0 1 0	An error occurred while the PPT was writing to its non-volatile memory.	None.
0 0 0 0 0 0 1 1	External communication equipment failure detected.	Check the external communication equipment.
0 0 0 0 1 0 1 1	Contact 7 of Option Switch U72 has been set (NVM initialized).	None.
0 0 0 0 1 1 0 0	NVM write in progress when power lost.	None.
0 0 0 0 1 1 0 1	An error occurred in communication between primary PPT and redundant PPT.	None.
0 0 0 0 1 1 1 0	PPT redundancy switches (Option Switch U72 contact 8) are the same.	Set U72 (position 8) on secondary PPT to 0 and U72 on the primary PPT to 1.
0 0 0 0 1 1 1 1	Primary PPT failed before its configuration was copied to the backup.	Reset the secondary PPT and enter the configuration.
0 0 0 1 0 0 0 0	Secondary PPT loop address (U75) does not match primary PPT.	Set secondary PPT loop address to match the primary PPT loop address.
0 0 0 1 0 0 0 1	Secondary PPT control mode or RS-232C mode (DCE or DTE) or ID (local or remote) does not match primary PPT.	Check the option switch settings (U72) on the secondary PPT.
0 0 0 1 0 0 1 0	BTM not responding.	Replace the BTM.
0 0 0 1 0 0 1 1	ROM checksum error.	Reset the PPT.
0 0 1 1 0 0 0 0	The system tried to force control to the redundant PPT while the primary PPT was still functioning.	None.
0 0 1 1 0 0 0 1	A fault in either the CPU or MEM boards exists.	Replace the PPT.
0 0 1 1 0 0 1 0	An addressing error occurred on internal microprocessor address bus.	Reset the PPT.
0 0 1 1 0 0 1 1	Attempt to execute an illegal processor instruction.	Reset the PPT.

Table 5-1. Table 5-1. PPT Error Codes (continued)

LED 8 7 6 5 4 3 2 1	Meaning	Corrective Action
0 0 1 1 0 1 0 1	Microprocessor received spurious exception vector.	Reset the PPT.
0 0 1 1 0 1 1 0	A divide by 0 or CHK instruction was expected.	Reset the PPT.
0 0 1 1 0 1 1 1	TRAP instruction was executed.	None.
0 0 1 1 1 1 1 1	The PPT has stopped because the user pressed the Stop pushbutton.	Reset the PPT.
0 0 0 0 0 0 0 0 ¹	The secondary PPT configuration is not copied from the primary PPT yet.	None.
1 0 0 0 0 0 0 0 ¹	The secondary PPT correctly copied the primary configuration and is ready to take over.	None.

1. These codes apply to the secondary PPT in a redundant configuration.

Status Bytes

Five status bytes provide information about Plant Loop to Plant Loop Transfer Module status. These bytes are available through any operator interface such as the Operator Interface Station (OIS). Refer to the instruction for your operator interface for an explanation of how to access status bytes. Table 5-2 lists the status bytes. Table 5-3 lists the status byte definitions.

Table 5-2. Status Bytes

Byte	Bit+							
	7	6	5	4	3	2	1	0
1	ES	MODE		TYPE				
2	FTX	BAC	RIO	LIO	N/A	NVI	CFG	N/A
3	PCU	MEM	NEF	N/A	N/A	N/A	N/A	N/A
4	LIE	LRE	LRE	LTE	LTE	N/A	N/A	N/A
5	N/A	N/A	N/A	N/A	N/A	N/A	N/A	N/A

Table 5-3. Status Byte Definitions

Field	Value	Description
Byte 1		
ES	80	Error Summary (0-OK, 1-Error)
MODE	60	Module Mode (00-Config, 01-Error, 11-Exec)
TYPE	1F	Module Type Code = Hex 11 (INPPT01)
Byte 2		
FTX	80	First Time in Execute (0-No, 1-Yes)
BAC	40	Backup PPT Status (0-OK, 1-Bad)
RIO	20	Summary Remote I/O Status (0-OK, 1-Bad)
LIO	10	Summary Local I/O Status (0-OK, 1-Bad)
N/A		Not Applicable
NVI	04	NVM Checksum Error (0-OK, 1-Bad)
CFG	02	Default Configuration (0-No, 1-Yes)
N/A		Not Applicable
Byte 3		
PCU	01	One or more PCUs offline (0-No, 1-Yes)
MEM	02	Memory Full (0-No, 1-Yes)
NEF	03	Node Environment Failure (0-No, 1-Yes)
Bits 0-4		Not Applicable
Byte 4		
LIE	80	LIM Internal Error
LRE	40	Loop Receive Error Channel 1
LRE	20	Loop Receive Error Channel 2
LTE	40	Loop Transmit Error Channel 1
LTE	80	Loop Receive Error Channel 2
Bits 0-3		Not Applicable
Byte 5		
Bits 0-7		Not Applicable

Table 5-4. LIM Edge Connector P3 Pin Assignments

Pin No.	Signal	Pin No.	Signal
1	Loop 2 In (+)	13	Loop 2 Bypass Control
2	Loop 2 In (-)	14	Cable Shield
3	Cable Shield	A	Cable Shield
4	Loop 1 Out (+)	D	Loop 1 Out (-)
5	Loop 1 Out (+)	E	Loop 1 Out (-)
6	Loop 1 In (+)	F	Cable Shield
7	Loop 1 In (-)	H	Loop 2 Bypass Control
8	Cable Shield	K	Loop 2 Out (-)
9	Loop 2 Out (+)	L	Loop 2 Out (-)
10	Loop 2 Out (+)	M	Cable Shield
11	Cable Shield	S	Cable Shield

Table 5-5. BTM Edge Connector P1 Pin Assignments

Pin No.	Signal	Pin No.	Signal
1	+5 VDC	2	+5 VDC
3	N/C	4	N/C
5	Common	6	Common
7	+15 VDC	8	-15 VDC
9	Power Fail Interrupt	10	Power Fail Interrupt
11	Module Bus	12	Module Bus

Table 5-6. PPT CPU Board Edge Connector P2 Pin Assignments

Pin No.	Signal	Pin No.	Signal
1	Data Bit D1	2	Data Bit D0
3	Data Bit D3	4	Data Bit D2
5	Data Bit D5	6	Data Bit D4
7	Data Bit D7	8	Data Bit D6
9	Clock	10	Sync
11	N/C	12	N/C

NOTE: All data bits are low true.

Table 5-7. PPT CPU Board Edge Connector P3 Pin Assignments

Pin No.	Signal	Pin No.	Signal
1	SAC Link (+)	A	SAC Link (-)
2	Redundancy Link Transmit Data (+)	B	Redundancy Link Transmit Data (-)
3	Redundancy Link Receive Data (-)	C	Redundancy Link Receive Data (+)
4	Terminal Port Transmit Data	D	Terminal Port Receive Data
5	Terminal Port Request to Send	E	Terminal Port Clear to Send
6	Terminal Port Data Carrier Detect	F	N/A
7	Printer Port Transmit Data	H	Printer Port Receive Data
8	Printer Port Request to Send	J	Printer Port Clear to Send
9	Printer Port Data Carrier Detect	K	N/A

Table 5-7. PPT CPU Board Edge Connector P3
Pin Assignments (continued)

Pin No.	Signal	Pin No.	Signal
10	Digital Output 1 (+)	L	Digital Output 1 (-)
11	Digital Output 2 (+)	M	Digital Output 2 (-)
12	N/A	N	N/A
13	N/A	P	N/A
14	N/A	R	N/A
15	N/A	S	N/A

SECTION 6 - MAINTENANCE

INTRODUCTION

The Plant Loop to Plant Loop Remote Interface (INPPR01) requires minimal maintenance. The following maintenance schedule will ensure trouble free service.

NOTE: Only qualified personnel should perform maintenance.

MAINTENANCE SCHEDULE

The PPR maintenance schedule is shown in Table 6-1. Perform these tasks at the specified intervals.

Table 6-1. Maintenance Schedule

Task	Interval
Clean and check all cable connections to the INLIM03, INBTM01 and INPPT01.	Every 6 months or during plant shutdown, whichever occurs first.
Use a static vacuum cleaner to remove dust from: Modules Module Mounting Unit Fan Assembly Power Entry Panel	Every 6 months or during plant shutdown, whichever occurs first.

SECTION 7 - REPAIR/REPLACEMENT PROCEDURES

INTRODUCTION

This section explains the replacement procedures for the Plant Loop to Plant Loop Remote Interface (INNPPR01). There are no special tools required to replace an interface module.

NOTE: Always use the Bailey Field Static Kit (P/N 1948385A1) when working with the interface modules. This kit connects the static dissipative work surface and technician to the same ground point.

MODULE REPAIR/REPLACEMENT

If you determine an interface module is faulty, replace it with a new one. **DO NOT** try to repair the module; replacing components may affect the module performance. You can remove the module while system power is supplied. To replace a module:

1. Press the stop pushbutton and wait for the status LED to turn red.
2. Push and turn the two front panel captive latches one half turn to unlatch the module. It is unlatched when the slots on the latches are vertical and the open end of the slots face away from the module.
3. Gently slide the module out of the MMU.
4. Configure the replacement module switch and jumper settings. Ensure they are set the same as the original module.
5. In the same slot assignment as the original module, align the replacement module with the guide rails in the MMU; gently slide it in until the front panel is flush with the top and bottom of the MMU frame.
6. Push and turn the two captive retaining latches on the module faceplate one half turn to the latched position. It is latched when the slots on the latches are vertical and the open ends face the center of the module.
7. Return to normal operation.

SECTION 8 - SUPPORT SERVICES

INTRODUCTION

Bailey Controls is ready to assist in the use of its products. Requests for sales, applications services, installation, repair, overhaul and maintenance contract services should be made to the nearest sales office.

REPLACEMENT PARTS AND ORDERING INFORMATION

If you are making repairs at your own facility, replacement parts should be ordered through a Bailey sales office. Provide the following information for parts orders:

1. Part description, part number and quantity.
2. Model, serial number (if applicable) and ratings of the assembly containing the ordered part.
3. Bailey publication number and reference used in identifying the part.

When ordering standard parts from Bailey Controls, use the part number and description from the Replacement Parts section of the manual. Parts not having a commercial description in the Replacement Parts section must be ordered from a Bailey Controls sales office.

TRAINING

Bailey Controls has a modern training facility equipped to provide service and repair instructions. This facility is available for in-plant training of your personnel. Contact a Bailey Controls sales office for information on available classes and scheduling.

TECHNICAL DOCUMENTATION

You can obtain additional copies of this manual through the nearest Bailey sales office. Copies, over and above those provided with the original purchase, are available at a minimum charge to the customer. Contact a Bailey Controls sales office for information.

APPENDIX A - TERMINATION UNIT CONFIGURATION (NTMF01)

INTRODUCTION

The INPPT01 uses the NTMF01 for termination. Figure A-1 shows the dipshunt configuration required when connecting a local and remote PPT (DTE) via a modem (DCE). Figure A-2 and A-3 show the dipshunt configuration required when directly connecting a local PPT (DTE) to a remote PPT (DCE) via a cable. Figure A-4 shows how to configure the dipshunts so that port 1 can drive a diagnostics terminal. Figure A-5 shows the RS-232-C signals and the associated DB-25 pin assignments.

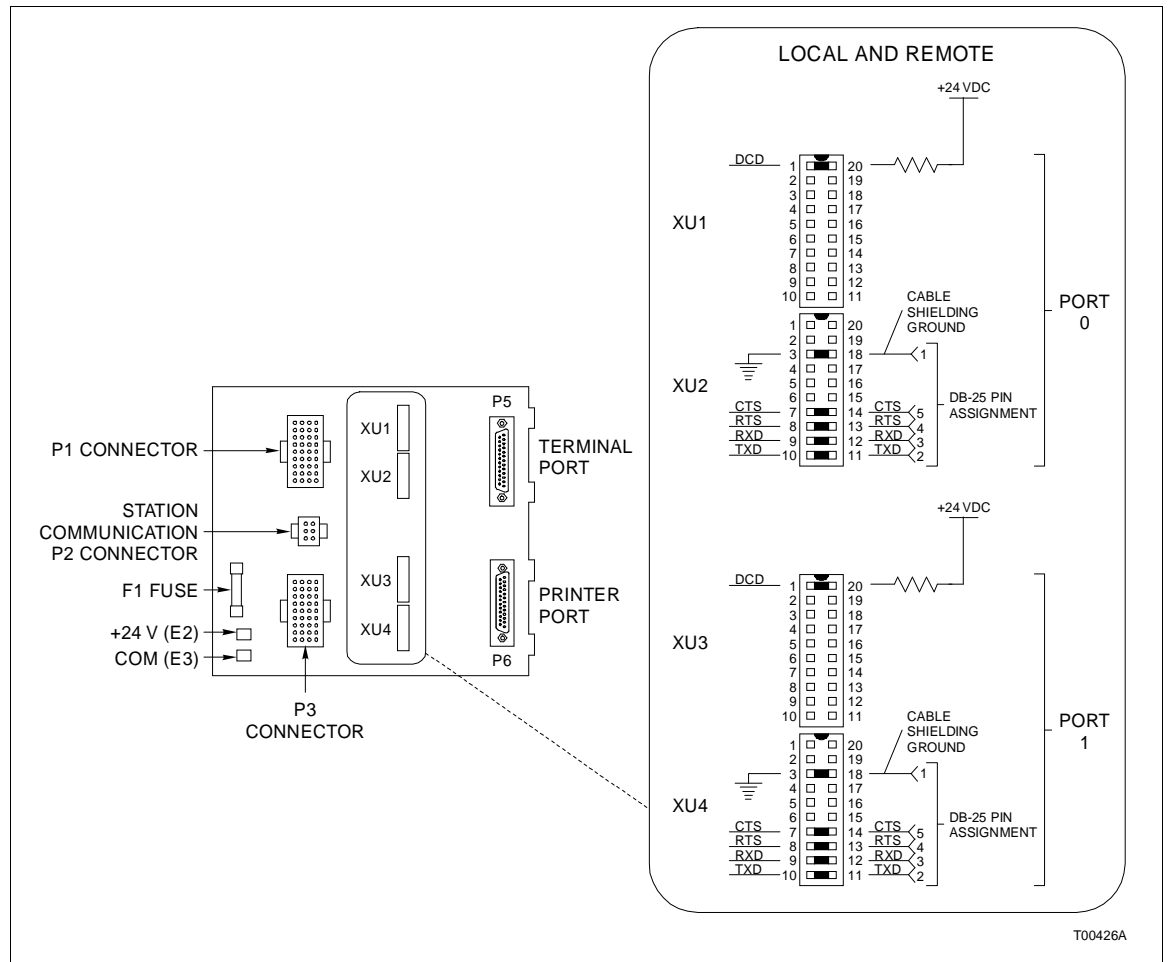

Figure A-1. Dipshunt Configuration for PPT Acting as DTE (Requires Modem or Other DCE)

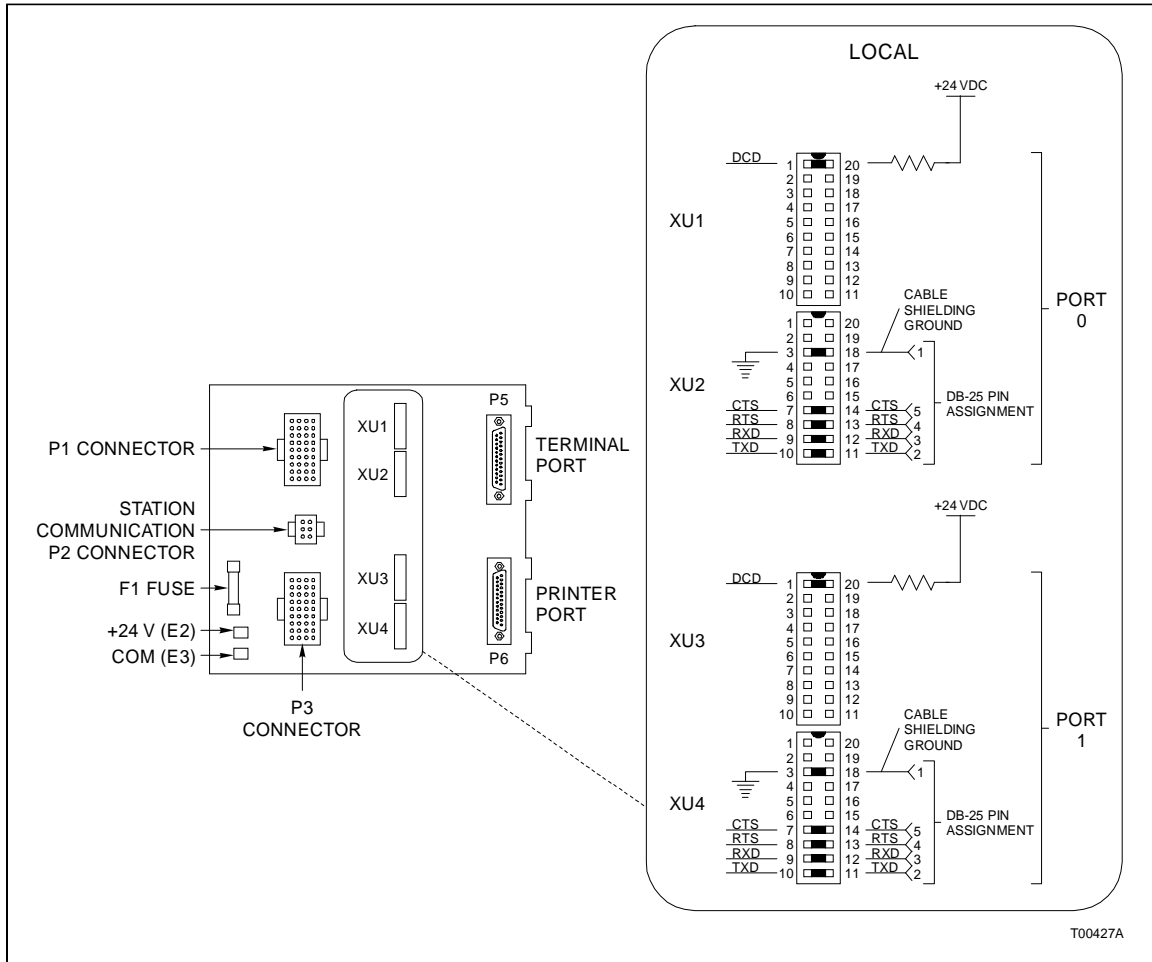

Figure A-2. Dipshunt Configuration for Direct Connection with Local PPT Acting as DTE

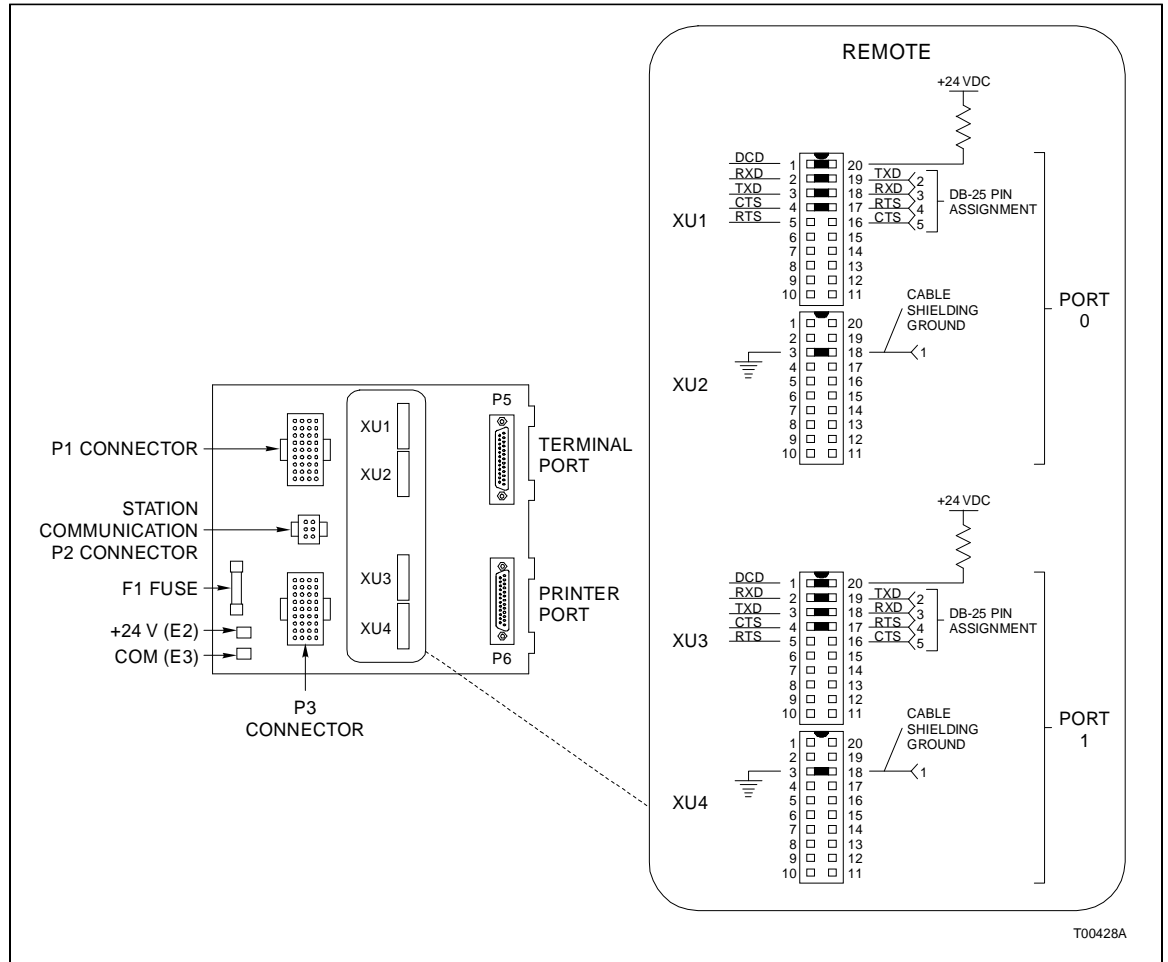

Figure A-3. Dipshunt Configuration for Direct Connection with Remote PPT Acting as DCE

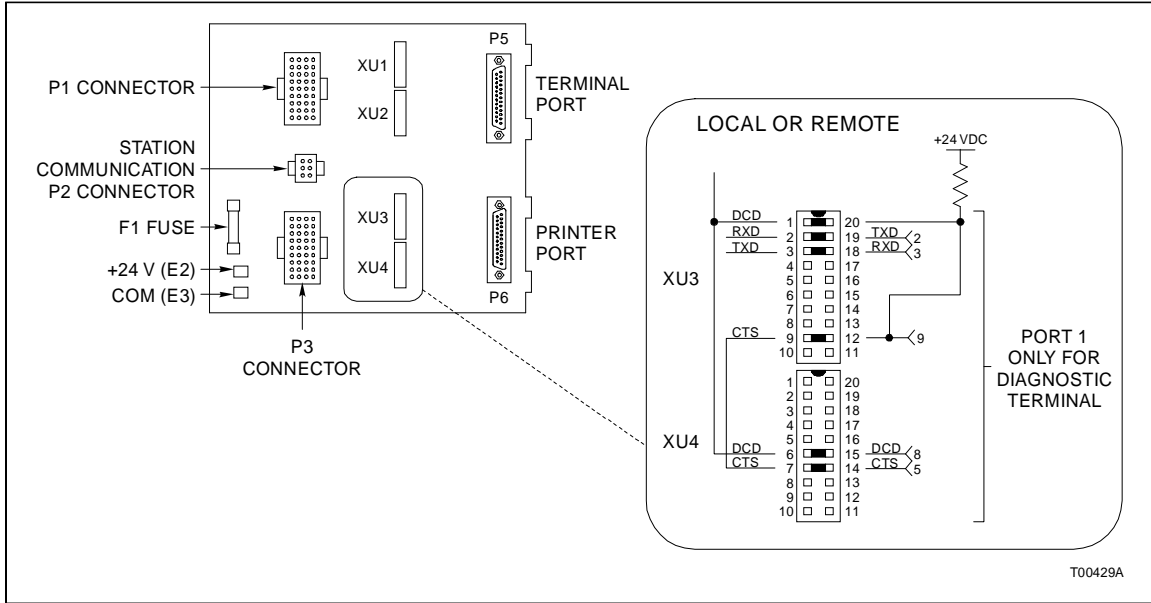
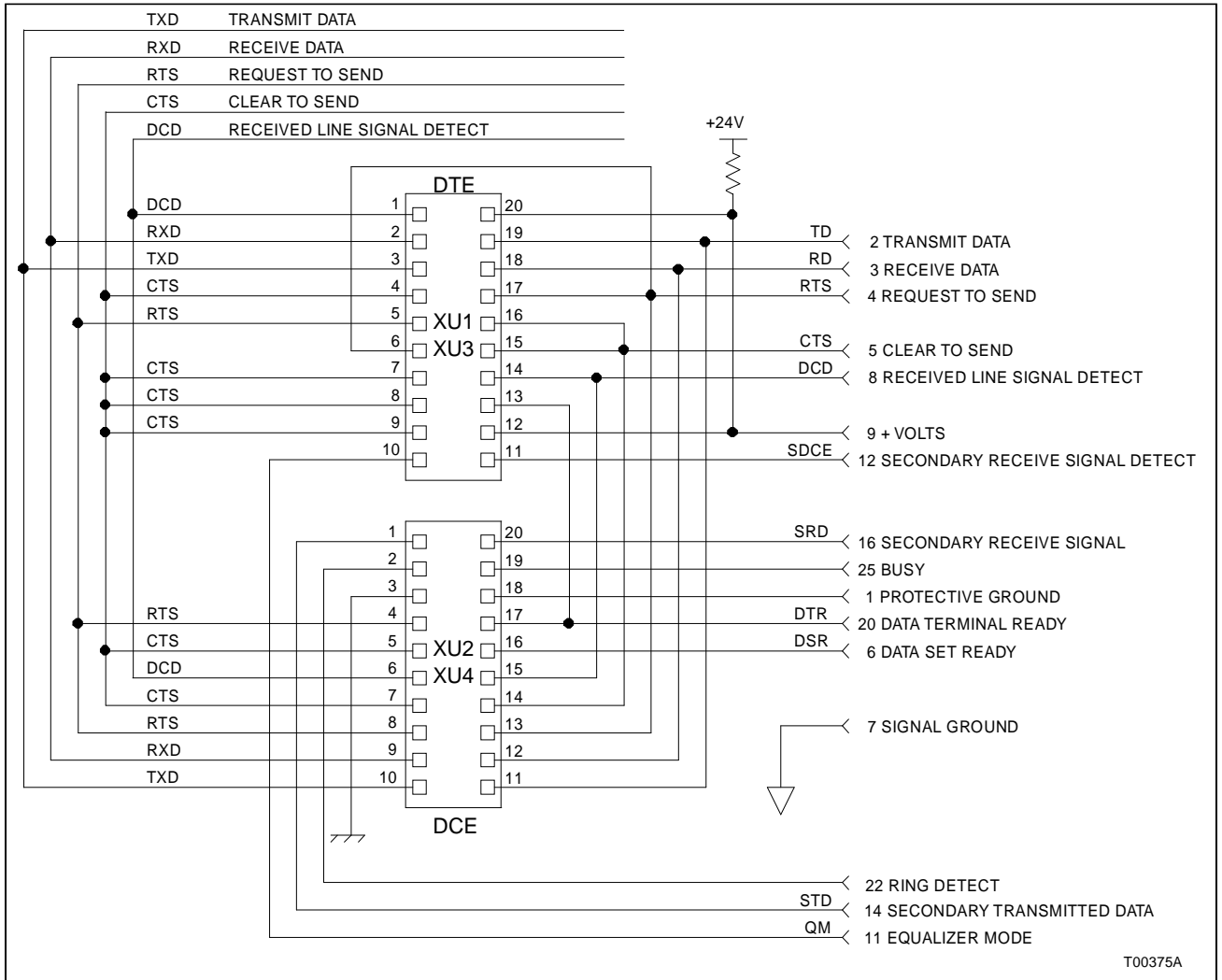

Figure A-4. Dipshunt Configuration for Diagnostic Terminal (Port 1 only)



T00375A

Figure A-5. DB-25 Pin Assignments and RS-232-C Signals

APPENDIX B - TERMINATION UNIT CONFIGURATION (NTCL01)

INTRODUCTION

The INLIM03 uses the NTCL01 for termination. Table B-1 lists the terminal assignments and Table B-2 lists the BNC terminal assignments for the loop input/output connections. Table B-3 provides jumper settings associated with cable type. Figure B-1 shows twinax cable connections for the NTCL01.

NOTE: Twinax cables connect to the terminals. Coax cables connect to the BNC connectors.

Table B-1. NTCL01 Terminal Assignments

Terminal Number TB1	Assignments	Terminal Number TB3	Assignments
1	Loop 1 In, +	1	Loop 2 In, +
2	Loop 1 In, -	2	Loop 2 In, -
3	Loop 1 In, Shield	3	Loop 2 In, Shield
4	no connection	4	no connection
5	Loop 1 Out, +	5	Loop 2 Out, +
6	Loop 1 Out, -	6	Loop 2 Out, -
7	Loop 1 Out, Shield	7	Loop 2 Out, Shield
8	Power System Status 1	8	Power System Status 2

Table B-2. BNC Terminal Assignments

BNC Number	Assignments	BNC Number	Assignments
J1	Loop 1 In	J8	Loop 2 In
J2	Loop 1 Out	J9	Loop 2 Out

Table B-3. Jumper Settings and Cable Types

NLIM03		
JUMPER NO.	TWINAX	COAX
J3, J10		
J4-J7, J11-J14		
J15-J18		

POST NUMBERS

T00365A

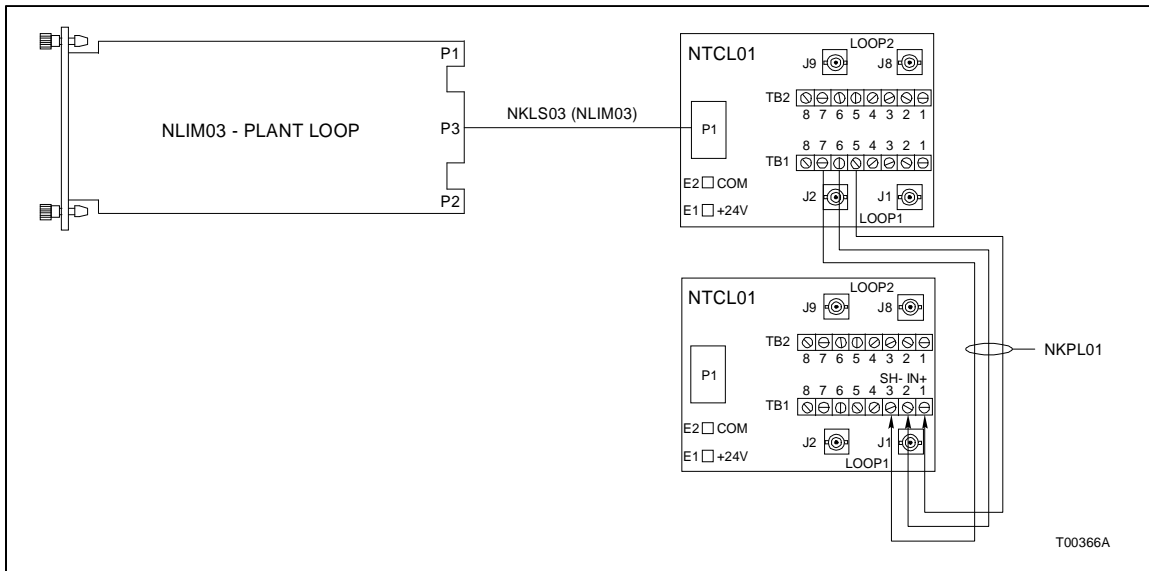

Figure B-1. NTCL01 Termination Unit and Terminal Assignments

APPENDIX C - TERMINATION MODULE CONFIGURATION (NIMF01/NIMF02)

INTRODUCTION

The INPPT01 can use the NIMF01 for termination. The NIMF02 is required when terminating redundant interfaces. The dipshunt configurations shown in Figure C-1 through C-4 apply to the NIMF01 and NIMF02. Figure C-1 shows the dipshunt configuration required when connecting a local and remote PPT (DTE) via a modem (DCE). Figure C-2 and C-3 show the dipshunt configuration required when directly connecting a local PPT (DTE) to a remote PPT (DCE) via a cable.

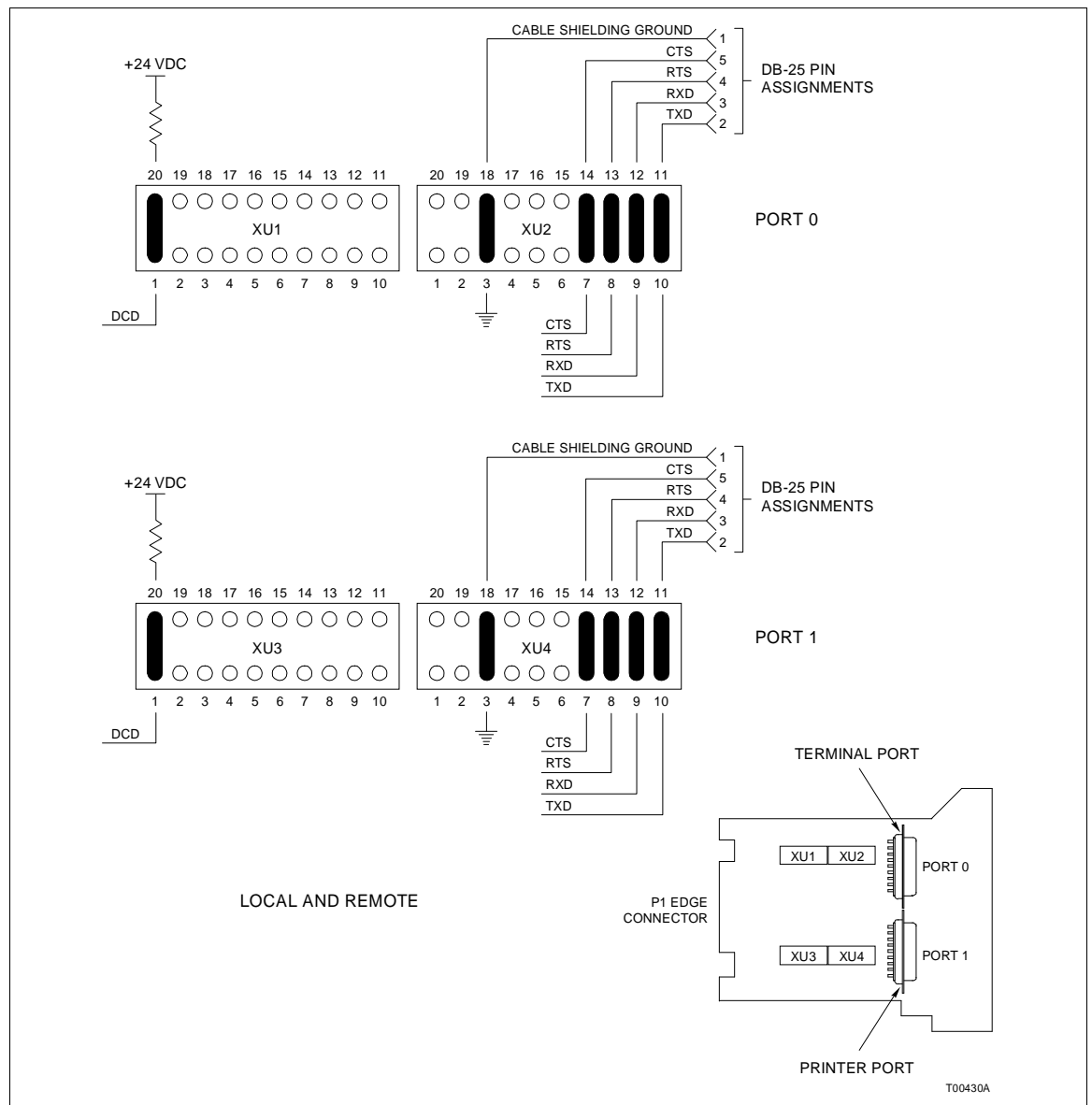

Figure C-1. Dipshunt Configuration for PPT Acting as DTE (requires Modem or Other DCE)

Figure C-3 shows how to configure the dipshunts so that port 1 can drive a diagnostics terminal.

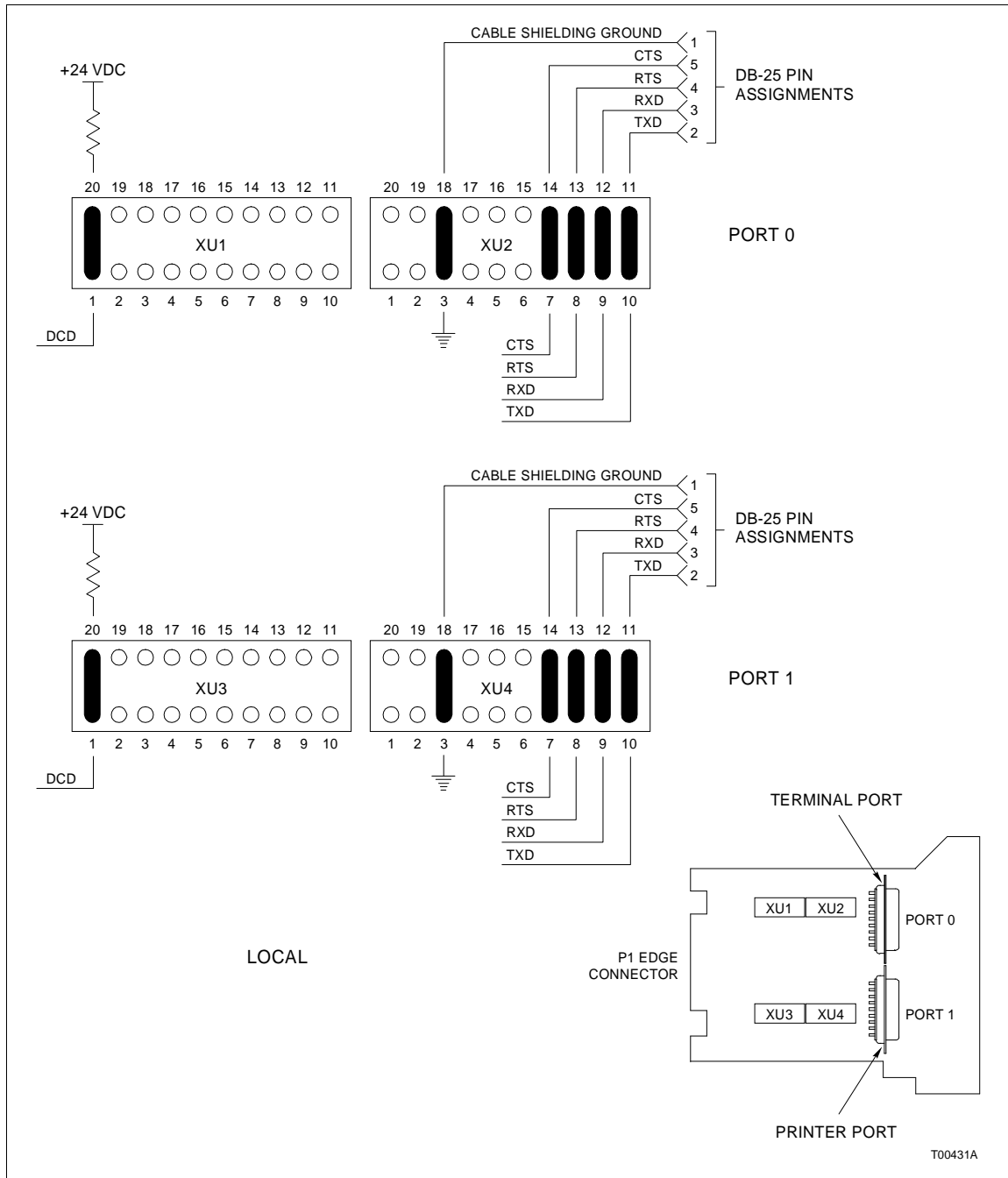

Figure C-2. Dipshunt Configuration for Direct Connection of Local PPT Acting as DTE

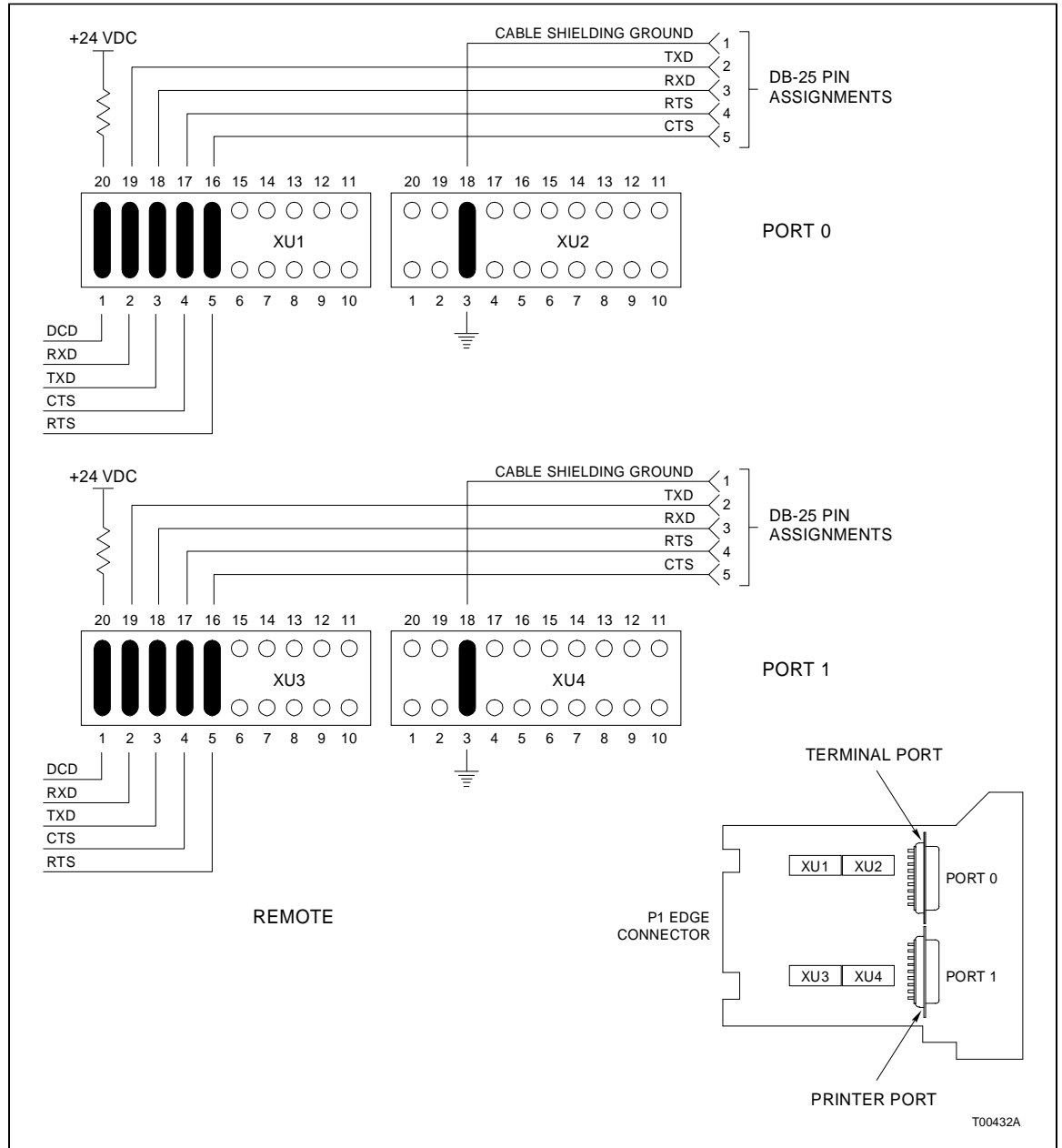

Figure C-3. Dipshunt Configuration for Direct Connection of Remote PPT Acting as DCE

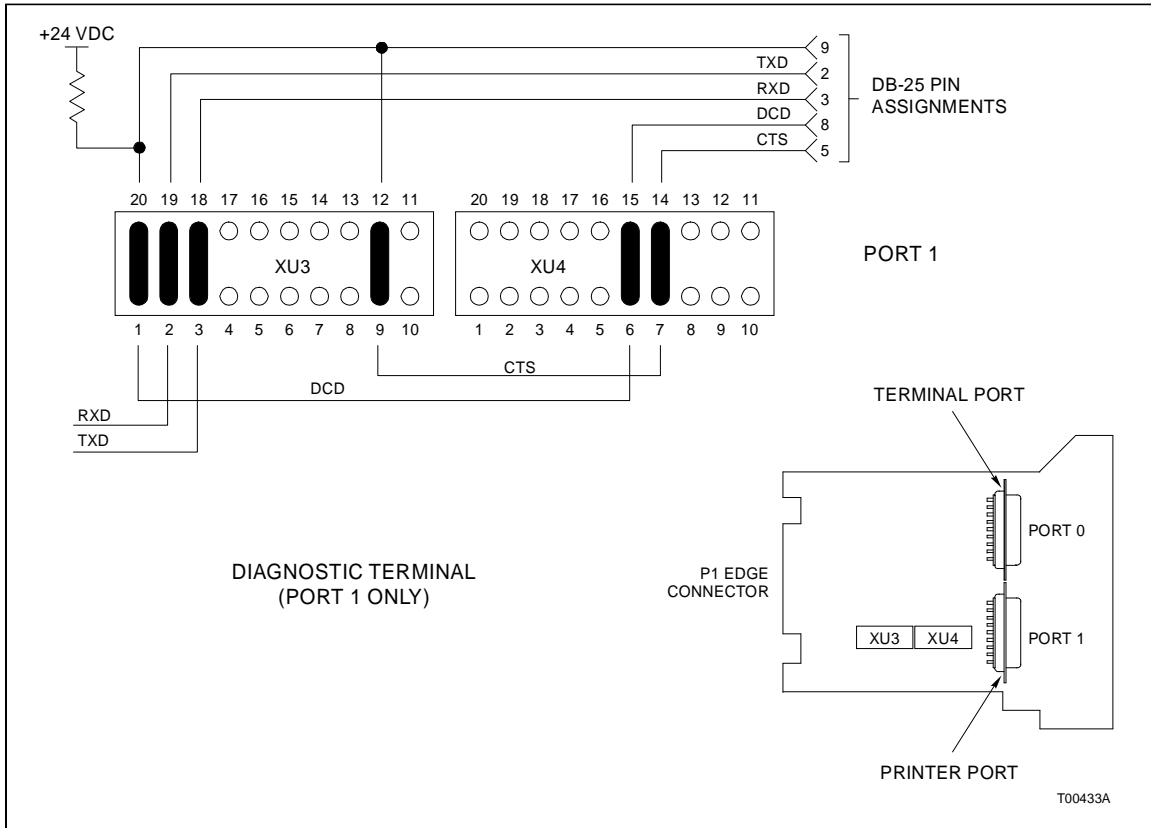

Figure C-4. Dispsihunt Configuration for Diagnostic Terminal

APPENDIX D - TERMINATION MODULE CONFIGURATION (NICL01)

INTRODUCTION

The INLIM03 can use the NICL01 for termination. Table D-1 lists the terminal assignments for the loop input/output connections. Table D-2 provides jumper settings associated with cable type. Figure D-1 shows twinax cable connections for NICL01.

NOTE: Twinax cables connect to the terminals. Coax cables connect to the BNC connectors.

CAUTION	Ensure that the end marked J1 is connected to P1 on the NICL01, and J2 is connected to the LIM. Failure to do so could result in module damage (see Figure D-1).
ATTENTION	S'assurez que L'extremite identifiee par J1 est reliee a P1 du module NICL01 et que J2 est reliee au module LIM. Sinon, les modules pourraient etre endommages (voir la figure D-1).

Table D-1. NICL01 Terminal Assignments

TB1 Terminal	Assignments	TB2 Terminal	Assignments	TB3 Terminal	Assignments
1	Ground	4	Power System Status 1	25	Loop 1 Out, Shield
2	Common	5	Power System Status 2	26	Loop 1 Out, -
3	+24 VDC	6	Loop 2 In, +	27	Loop 1 Out, +
		7	Loop 2 In, -	28	Loop 1 In, Shield
		8	Loop 2, Shield	29	Loop 1 In, -
		9	Loop 2 Out, +	30	Loop 1 In, +
		10	Loop 2 Out, -	31	no connection
		11	Loop 2 Out, Shield	32	no connection

Table D-2. BNC Assignments

BNC Number	Assignments
J1	Loop 1 In
J2	Loop 1 Out
J8	Loop 2 In
J9	Loop 2 Out

Table D-3. Jumper Settings and Cable Types

NLIM03		
JUMPER NO.	TWINAX	COAX
J3, J10		
J4-J7, J11-J14		
J15-J18		

POST 1 2 3
 NUMBERS

T00365A

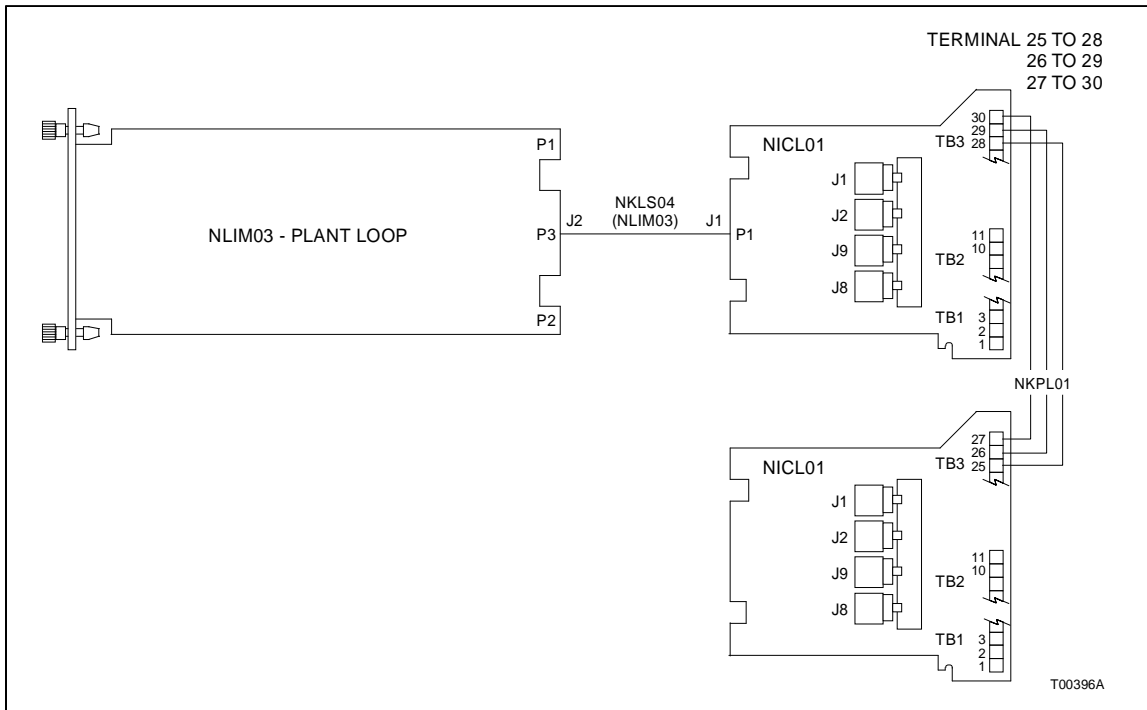

Figure D-1. Typical Twinax Cable Connection for the NICL01

Visit *Elsag Bailey* on the World Wide Web at <http://www.bailey.com>

Our worldwide staff of professionals is ready to meet *your* needs for process automation.
For the location nearest you, please contact the appropriate regional office.

AMERICAS

29801 Euclid Avenue
Wickliffe, Ohio USA 44092
Telephone 1-216-585-8500
Telefax 1-216-585-8756

ASIA/PACIFIC

152 Beach Road
Gateway East #20-04
Singapore 189721
Telephone 65-391-0800
Telefax 65-292-9011

EUROPE, AFRICA, MIDDLE EAST

Via Puccini 2
16154 Genoa, Italy
Telephone 39-10-6582-943
Telefax 39-10-6582-941

GERMANY

Graefstrasse 97
D-60487 Frankfurt Main
Germany
Telephone 49-69-799-0
Telefax 49-69-799-2406