

PWC90

# Instruction

## Operation Personal Work Center 90 (Release 1.0)

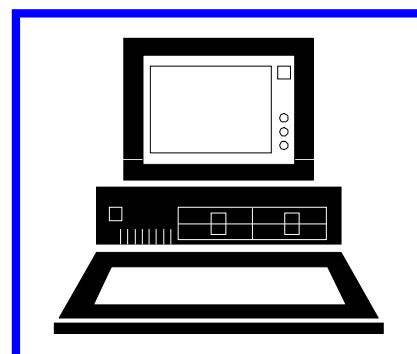
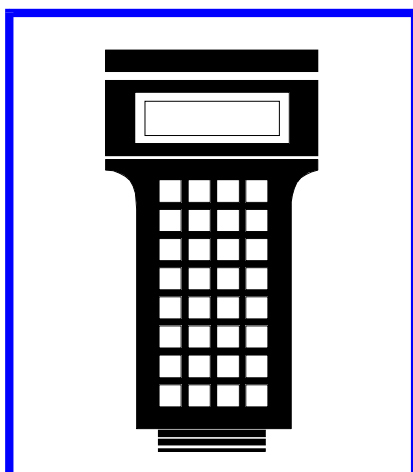
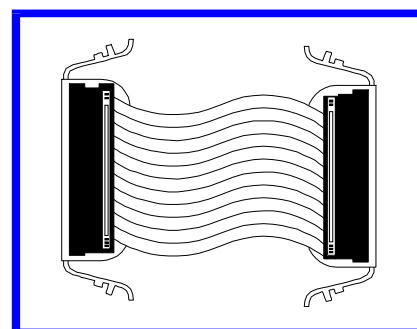
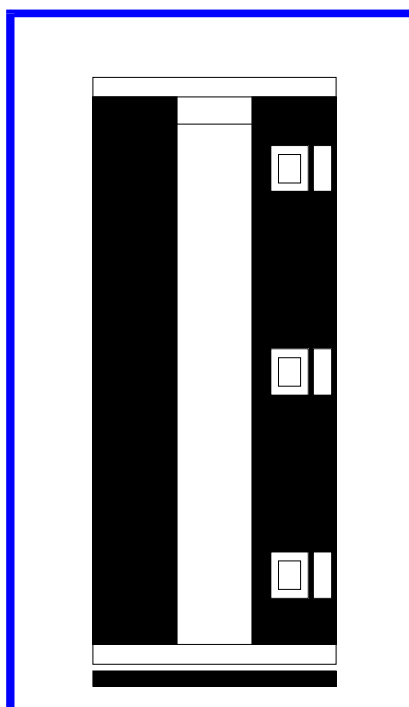
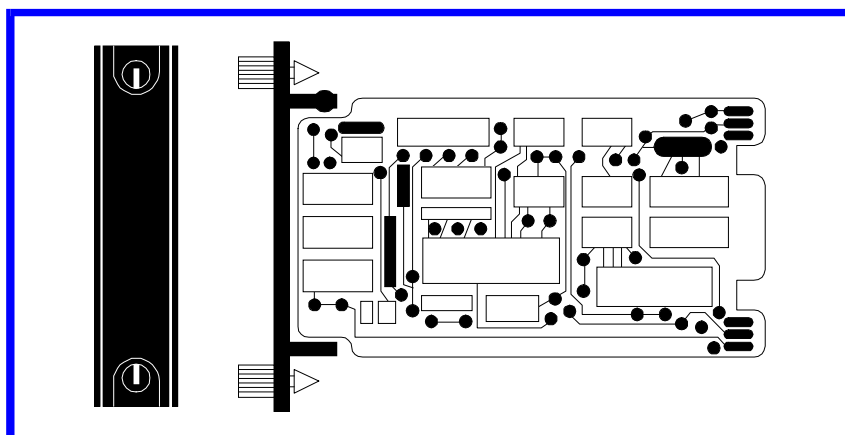
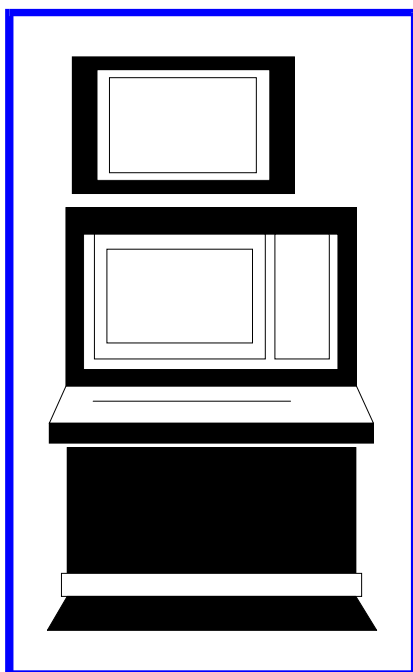

**WARNING** notices as used in this instruction apply to hazards or unsafe practices that could result in personal injury or death.

**CAUTION** notices apply to hazards or unsafe practices that could result in property damage.

**NOTES** highlight procedures and contain information that assists the operator in understanding the information contained in this instruction.

## WARNING

### INSTRUCTION MANUALS

DO NOT INSTALL, MAINTAIN, OR OPERATE THIS EQUIPMENT WITHOUT READING, UNDERSTANDING, AND FOLLOWING THE PROPER **Bailey Controls** INSTRUCTIONS AND MANUALS; OTHERWISE, INJURY OR DAMAGE MAY RESULT.

### RADIO FREQUENCY INTERFERENCE

MOST ELECTRONIC EQUIPMENT IS INFLUENCED BY RADIO FREQUENCY INTERFERENCE (RFI). CAUTION SHOULD BE EXERCISED WITH REGARD TO THE USE OF PORTABLE COMMUNICATIONS EQUIPMENT IN THE AREA AROUND SUCH EQUIPMENT. PRUDENT PRACTICE DICTATES THAT SIGNS SHOULD BE POSTED IN THE VICINITY OF THE EQUIPMENT CAUTIONING AGAINST THE USE OF PORTABLE COMMUNICATIONS EQUIPMENT.

### POSSIBLE PROCESS UPSETS

MAINTENANCE MUST BE PERFORMED ONLY BY QUALIFIED PERSONNEL AND ONLY AFTER SECURING EQUIPMENT CONTROLLED BY THIS PRODUCT. ADJUSTING OR REMOVING THIS PRODUCT WHILE IT IS IN THE SYSTEM MAY UPSET THE PROCESS BEING CONTROLLED. SOME PROCESS UPSETS MAY CAUSE INJURY OR DAMAGE.

## AVERTISSEMENT

### MANUELS D'OPÉRATION

NE PAS METTRE EN PLACE, RÉPARER OU FAIRE FONCTIONNER L'ÉQUIPEMENT SANS AVOIR LU, COMPRIS ET SUIVI LES INSTRUCTIONS RÉGLEMENTAIRES DE **Bailey Controls** TOUTE NÉGLIGENCE À CET ÉGARD POURRAIT ÊTRE UNE CAUSE D'ACCIDENT OU DE DÉFAILLANCE DU MATÉRIEL.

### PERTURBATIONS PAR FRÉQUENCE RADIO

LA PLUPART DES ÉQUIPEMENTS ÉLECTRONIQUES SONT SENSIBLES AUX PERTURBATIONS PAR FRÉQUENCE RADIO. DES PRÉCAUTIONS DEVRONT ÊTRE PRISES LORS DE L'UTILISATION DU MATÉRIEL DE COMMUNICATION PORTATIF. LA PRUDENCE EXIGE QUE LES PRÉCAUTIONS À PRENDRE DANS CE CAS SOIENT SIGNALÉES AUX ENDROITS VOULUS DANS VOTRE USINE.

### PERTURBATIONS DU PROCÉDÉ

L'ENTRETIEN DOIT ÊTRE ASSURÉ PAR UNE PERSONNE QUALIFIÉE EN CONSIDÉRANT L'ASPECT SÉCURITAIRE DES ÉQUIPEMENTS CONTRÔLÉS PAR CE PRODUIT. L'AJUSTEMENT ET/OU L'EXTRACTION DE CE PRODUIT PEUT OCCASIONNER DES À-COUPS AU PROCÉDÉ CONTRÔLE LORSQU'IL EST INSÉRÉ DANS UNE SYSTÈME ACTIF. CES À-COUPS PEUVENT ÉGALEMENT OCCASIONNER DES BLESSURES OU DES DOMMAGES MATÉRIELS.

## NOTICE

The information contained in this document is subject to change without notice.

Bailey Controls Company, its affiliates, employees, and agents, and the authors and contributors to this publication specifically disclaim all liabilities and warranties, express and implied (including warranties of merchantability and fitness for a particular purpose), for the accuracy, currency, completeness, and/or reliability of the information contained herein and/or for the fitness for any particular use and/or for the performance of any material and/or equipment selected in whole or part with the user of/or in reliance upon information contained herein. Selection of materials and/or equipment is at the sole risk of the user of this publication.

This document contains proprietary information of Bailey Controls Company, Elsag Bailey Process Automation, and is issued in strict confidence. Its use, or reproduction for use, for the reverse engineering, development or manufacture of hardware or software described herein is prohibited. No part of this document may be photocopied or reproduced without the prior written consent of Bailey Controls Company.

---

## Preface

---

This instruction covers the operation of the Personal Work Center 90 (PWC90). PWC90 operates in the Windows NT™ version 4.0 operating system. It communicates with the INFI 90® OPEN system via the INICIO3 connected to the INFI-NET® system.

The PWC90 console provides an operator interface to the INFI 90 OPEN system.

Special features of the PWC90 console include:

- Online process graphic configuration.
- Configuration and online changing of the tag database.
- Changing the operating parameters of tags.
- Monitoring and logging of alarms.
- Multilevel security system.
- Creation of spreadsheets using Microsoft EXCEL.
- Microsoft Windows access to other software applications.
- Tag summaries application.
- Module details application.
- Block details application.
- Server diagnostics application.
- Fixed and/or custom display hierarchy.
- Open standard data server (@aGlance™).

## List of Effective Pages

---

Total number of pages in this instruction is 284, consisting of the following:

<b>Page No.</b>	<b>Change Date</b>
Preface	Original
List of Effective Pages	Original
iii through xiv	Original
1-1 through 1-7	Original
2-1 through 2-33	Original
3-1 through 3-23	Original
4-1 through 4-61	Original
5-1 through 5-4	Original
6-1 through 6-15	Original
7-1 through 7-10	Original
8-1 through 8-10	Original
9-1 through 9-16	Original
10-1 through 10-8	Original
11-1 through 11-42	Original
12-1 through 12-6	Original
13-1 through 13-6	Original
14-1 through 14-10	Original
15-1 through 15-4	Original
16-1 through 16-5	Original
17-1 through 17-8	Original
Index-1 through Index-2	Original

When an update is received, insert the latest changed pages and dispose of the superseded pages.

**NOTE:** On an update page, the changed text or table is indicated by a vertical bar in the outer margin of the page adjacent to the changed area. A changed figure is indicated by a vertical bar in the outer margin next to the figure caption. The date the update was prepared will appear beside the page number.

---

# Table of Contents

	<i>Page</i>
<b>SECTION 1 - INTRODUCTION</b> .....	<b>1-1</b>
INTRODUCTION .....	1-1
INTENDED USER .....	1-1
FUNCTIONAL DESCRIPTION .....	1-1
User Interface .....	1-2
PWC90 Console Management Features .....	1-2
Hierarchical Displays .....	1-2
Logging .....	1-3
Trends .....	1-3
Graphic Displays .....	1-3
Process Alarms .....	1-3
Events .....	1-3
Message Review .....	1-4
PWC90 Console Utilities .....	1-4
Printer Review .....	1-4
Operating Parameters .....	1-4
Tag Summaries .....	1-4
Server Diagnostics .....	1-5
Module Details .....	1-5
Block Details .....	1-5
DOCUMENT CONVENTIONS .....	1-5
REFERENCE DOCUMENTS .....	1-5
GLOSSARY OF TERMS AND ABBREVIATIONS .....	1-6
<b>SECTION 2 - PWC90 CONSOLE USER INTERFACE</b> .....	<b>2-1</b>
INTRODUCTION .....	2-1
PWC90 CONSOLE APPEARANCE .....	2-1
INPUT DEVICES .....	2-1
Pointing Devices .....	2-2
Keyboard .....	2-3
PWC90 CONSOLE DISPLAY .....	2-6
Description of Window Operations - General .....	2-7
Typical Window Components .....	2-7
Directing Input to a Window - Keyboard Focus .....	2-8
Move .....	2-9
Resize .....	2-9
Maximize .....	2-10
Restore .....	2-10
Other Window Features .....	2-11
Keyboard Traversal .....	2-16
System Window .....	2-18
Components .....	2-18
Menu Functions .....	2-19
Mini-Alarm Window .....	2-21
Operator Window .....	2-23
Operator Window Operations .....	2-25
Open .....	2-27
Page Up/Page Down .....	2-28
Forward/Back .....	2-28
Close .....	2-28
Resize .....	2-29
Arrange Windows Function .....	2-29
Summary - Window Types, Components and Operations .....	2-29

## Table of Contents (continued)

	<i>Page</i>
<b>SECTION 3 - PWC90 CONSOLE FEATURES .....</b>	<b>3-1</b>
INTRODUCTION .....	3-1
GETTING STARTED .....	3-1
System Default State .....	3-1
Logging In .....	3-2
Logging Out .....	3-4
Changing Your Password .....	3-5
SYSTEM FEATURES .....	3-7
Security .....	3-8
Message Configuration .....	3-9
Message Text .....	3-9
Message Priority .....	3-9
Message Destination Area .....	3-9
Send the Operator Message .....	3-11
Message Routing .....	3-11
Message Color Definition .....	3-12
Message Indentation Definition .....	3-12
Message Class: Process Alarm Messages .....	3-12
Message Class: System Event Messages .....	3-13
Message Class: Operator Messages .....	3-13
Message Class: Operating Status Messages .....	3-13
Message Class: Operating Errors .....	3-14
Message Class: Operator Actions .....	3-14
Message Filter Parameters .....	3-14
SYSTEM STATUS DISPLAY .....	3-15
PWC90 Nodes .....	3-17
Node Name .....	3-17
Info Menu .....	3-18
INFI 90 OPEN Server Nodes .....	3-19
Utilities Menu .....	3-20
Printer Queue Control .....	3-21
Printer Queue Information .....	3-22
<b>SECTION 4 - HIERARCHICAL PROCESS DISPLAYS .....</b>	<b>4-1</b>
INTRODUCTION .....	4-1
SUMMARY DISPLAY .....	4-2
GROUP DISPLAY .....	4-6
Group Legends .....	4-8
Faceplate Tagnames .....	4-8
Tag Descriptions .....	4-8
Status Area .....	4-8
PROCESS CONTROL FUNCTIONS .....	4-12
Control Faceplates .....	4-12
Control Tags .....	4-13
Control Inhibit .....	4-13
Common Control Faceplate Attributes .....	4-14
Loop Control .....	4-15
Station Faceplate .....	4-15
STATION Control .....	4-18
Device Control .....	4-20
Remote Control Memory Faceplate .....	4-20
RCM Control .....	4-22
Remote Manual Set Constant Faceplate .....	4-23

## Table of Contents (continued)

	<i>Page</i>
<hr/>	
<b>SECTION 4 - HIERARCHICAL PROCESS DISPLAYS (continued)</b>	<b>4-24</b>
RMSC Control.....	4-24
Device Driver Faceplate .....	4-25
DD Control .....	4-26
Multi-state Device Driver Faceplate .....	4-27
MSDD Control .....	4-29
Remote Motor Control Block Faceplate .....	4-30
RMCB Control .....	4-33
DATA ACQUISITION FUNCTIONS .....	4-34
Data Acquisition Faceplates .....	4-34
Data Acquisition Tags .....	4-34
Control Inhibit .....	4-35
Common Data Acquisition Faceplate Attributes .....	4-35
Analog Faceplate Attributes .....	4-35
Digital Faceplate Attributes .....	4-38
Data Acquisition Analog Faceplate .....	4-40
DAANG Faceplate Attributes .....	4-40
DAANG Control .....	4-43
Data Acquisition Digital Faceplate .....	4-43
DADIG Faceplate Attributes .....	4-44
DADIG Control .....	4-46
Text String Faceplate .....	4-46
TEXTSTR Faceplate Attributes .....	4-47
TEXTSTR Control .....	4-49
PWC90 FACEPLATES .....	4-52
Analog Export .....	4-52
Digital Export .....	4-53
Module Status .....	4-54
INFI 90 OPEN Scanner Tag .....	4-55
POINT DISPLAY .....	4-56
Accessing the Point Display .....	4-56
Point Display .....	4-58
Tagname.....	4-58
Tag Description .....	4-58
Status Area .....	4-59
Info Pushbutton.....	4-59
Param Pushbutton.....	4-60
Process Display Area .....	4-60
<hr/>	
<b>SECTION 5 - LOGS .....</b>	<b>5-1</b>
INTRODUCTION .....	5-1
ACCESSING LOG PRINT .....	5-1
EVENT LOGS .....	5-2
SPREADSHEET LOGS .....	5-3
<hr/>	
<b>SECTION 6 - TREND DISPLAYS .....</b>	<b>6-1</b>
INTRODUCTION .....	6-1
TREND DISPLAY FORMAT .....	6-5
Trend Graph .....	6-5
Time Base and Size of Display Window .....	6-5
Trend Readout Arrow .....	6-6
Time at Arrow Button .....	6-6

## Table of Contents (continued)

	<i>Page</i>
<hr/>	
<b>SECTION 6 - TREND DISPLAYS (continued)</b>	
Trace On/Off Button .....	6-7
Display Option Button .....	6-8
Trace Scale Button .....	6-8
Trace Tag and Atom .....	6-8
Value at Arrow .....	6-8
Value Precision Indicator .....	6-8
Database Select Button .....	6-9
INFO Button .....	6-9
Compression Button and Arrows .....	6-10
Trend Compression Speed Factors .....	6-12
Zoom/UnZoom Button .....	6-14
Reset Button .....	6-14
Pause/Resume Button .....	6-15
Segment Button and Arrows .....	6-15
<hr/>	
<b>SECTION 7 - GRAPHICS .....</b>	<b>7-1</b>
INTRODUCTION .....	7-1
ACCESSING GRAPHIC DISPLAYS .....	7-2
CONTROL THROUGH GRAPHICS .....	7-3
DISPLAY VECTORING .....	7-5
ERROR INDICATION .....	7-6
ALARM ACKNOWLEDGMENT .....	7-7
ZOOM MENU ITEM .....	7-7
Pan Operations - Up, Down, Left, Right, Center .....	7-8
Zoom Operations - In, Out, Fit, Pick .....	7-9
Zoom and Pan Operations in Pop-Up Graphic Windows .....	7-10
Resizing the Zoomed/Panned Operator Window .....	7-10
<hr/>	
<b>SECTION 8 - PROCESS ALARMS .....</b>	<b>8-1</b>
INTRODUCTION .....	8-1
PROCESS ALARMS IN THE MINI-ALARM WINDOW .....	8-1
Process Alarm Priorities .....	8-1
Audible Alarm Format .....	8-1
Acknowledging Alarms in the Mini-Alarm Window .....	8-2
Filtering Alarms in the Mini-Alarm Window .....	8-2
PROCESS ALARM REVIEW .....	8-3
Accessing the Alarm Review Display .....	8-3
Alarm Review Display Acknowledgment .....	8-4
Display Vectoring from the Alarm Review Display .....	8-5
Filtering Alarms .....	8-6
Message Class: Process Alarm Messages .....	8-7
Message Class: Priority .....	8-8
Message Class: Area .....	8-8
Clearing and Setting Alarm Review Message Types .....	8-8
Sort Alarms in the Alarm Review .....	8-8
Freeze Alarm Review Display .....	8-9
Search Alarm Review Display .....	8-10
<hr/>	
<b>SECTION 9 - EVENTS .....</b>	<b>9-1</b>
INTRODUCTION .....	9-1
SYSTEM EVENT MESSAGES IN THE MINI-ALARM WINDOW .....	9-1

---

## Table of Contents (continued)

	<i>Page</i>
<hr/> <b>SECTION 9 - EVENTS (continued)</b>	
Audible Alarm Format for Event Messages .....	9-1
Acknowledging Event Messages in the Mini-Alarm Window .....	9-1
System Event Format .....	9-2
SYSTEM EVENT REVIEW .....	9-2
Accessing the Event Review Display .....	9-2
Event Review Display Acknowledgment .....	9-3
Filtering Event Messages .....	9-4
Message Class: System Event Messages .....	9-5
Clearing and Setting Event Review Message Types .....	9-6
Sort Event Messages in the Event Review Display .....	9-6
Freeze Event Review Display .....	9-7
EVENT HISTORIAN .....	9-7
Accessing the Event Historian .....	9-7
Scrolling the Event .....	9-8
Pause/Resume the Event Historian .....	9-9
Filtering Messages in the Event Historian .....	9-9
Filtering Messages by Time .....	9-10
Filtering Messages by Class and Type .....	9-11
Print Event Historian File .....	9-14
<hr/> <b>SECTION 10 - MESSAGE REVIEW ..... 10-1</b>	
INTRODUCTION .....	10-1
MESSAGES IN THE MINI-ALARM WINDOW .....	10-1
Audible Alarm Format for Operator Messages .....	10-1
Acknowledging Messages in the Mini-Alarm Window .....	10-1
Operator Message Format .....	10-2
MESSAGE REVIEW .....	10-2
Accessing the Message Review Display .....	10-2
Message Review Display Acknowledgment .....	10-3
Filtering Messages .....	10-4
Message Class: Operator Messages .....	10-5
Message Class: Priority .....	10-6
Clearing and Setting Message Review Message Types .....	10-6
Sort Messages in the Message Review Display .....	10-6
Freeze Message Review Display .....	10-7
<hr/> <b>SECTION 11 - PWC90 UTILITIES ..... 11-1</b>	
INTRODUCTION .....	11-1
Notes on QIC Tape Drive Use .....	11-2
Notes on DAT Tape Drive Use .....	11-2
BACKUP AND RESTORE .....	11-3
Backup Utility .....	11-3
Backing Up Network Wide Information .....	11-4
Backing Up Local Application Data .....	11-6
Backup Options .....	11-7
Performing the Backup .....	11-7
Restore Utility .....	11-9
List Tape Button .....	11-11
List Disk Button .....	11-12
Restore File Button .....	11-13
DATABASE MAINTENANCE .....	11-14

## Table of Contents (continued)

	<i>Page</i>
<hr/>	
<b>SECTION 11 - PWC90 UTILITIES (continued)</b>	
Historical Manual Entry .....	11-14
Viewing an Historical Database Value .....	11-15
Changing a Historical Database Value .....	11-17
Adding an Historical Database Value .....	11-17
Deleting an Historical Database Value .....	11-17
Database Maintenance Windows .....	11-18
Archival Database Maintenance .....	11-18
Archival Block Database Maintenance .....	11-21
ARCHIVAL UTILITIES .....	11-21
Archive Historical Data .....	11-22
Archive Historical Block Data .....	11-24
Restore Archival Data .....	11-26
Restore Archival Block Data .....	11-27
List Archival Block Data .....	11-28
ALARM GROUPS.....	11-28
CRT PRINT .....	11-32
Selecting the Image Type .....	11-32
Selecting the Printer .....	11-32
Printing the Image .....	11-33
OTHER APPLICATIONS.....	11-33
RELEASE ALL CONFIGURATION LOCKS .....	11-33
PWC90 HELP.....	11-34
QUICK KEYS .....	11-34
Accessing the Quick Keys Feature .....	11-35
Configuring Quick Keys .....	11-36
Configuring Quick Keys 33 Through 64 .....	11-37
Clearing Quick Key Assignments .....	11-38
Exiting Quick Keys .....	11-38
Summary - Quick Keys.....	11-38
CRT CONTEXT KEYS.....	11-39
Preparing the Context.....	11-39
Initial Display Layout - Login Context Key .....	11-39
Accessing CRT Context Keys.....	11-39
Configuring CRT Context Keys.....	11-40
Clearing CRT Context Keys .....	11-41
Exiting CRT Context Keys .....	11-41
Summary - CRT Context Keys .....	11-41
<hr/>	
<b>SECTION 12 - PRINTER REVIEW .....</b>	<b>12-1</b>
INTRODUCTION .....	12-1
USING PRINTER REVIEW .....	12-3
Scrolling the Printer Review Display.....	12-3
Pause/Resume the Printer Review Display .....	12-3
Time Selection .....	12-4
Printing Messages.....	12-5
<hr/>	
<b>SECTION 13 - OPERATING PARAMETERS.....</b>	<b>13-1</b>
INTRODUCTION .....	13-1
GENERAL TAB.....	13-2
INFI 90 TAB.....	13-2
TAG SPECIFIC TAB.....	13-3

---

## Table of Contents (continued)

	<i>Page</i>
<hr/>	
<b>SECTION 13 - OPERATING PARAMETERS</b> (continued)	
RED TAG TAB .....	13-4
SUBSTITUTE BUTTON .....	13-5
<hr/>	
<b>SECTION 14 - TAG SUMMARIES APPLICATION</b> .....	<b>14-1</b>
INTRODUCTION .....	14-1
USING TAG SUMMARIES .....	14-1
Designing a Query .....	14-2
Arithmetic Operators .....	14-5
Where Clause .....	14-6
Comparison Operators.....	14-6
Wildcards and the Like Clause .....	14-7
Logical Operators.....	14-7
Order by Clause.....	14-8
Query Results.....	14-8
Print Results.....	14-10
Query File Operations .....	14-10
<hr/>	
<b>SECTION 15 - SERVER DIAGNOSTICS</b> .....	<b>15-1</b>
INTRODUCTION.....	15-1
GENERAL TAB .....	15-2
MESSAGE TAB .....	15-2
TAGS TAB .....	15-3
<hr/>	
<b>SECTION 16 - MODULE DETAILS</b> .....	<b>16-1</b>
INTRODUCTION.....	16-1
GENERAL TAB .....	16-1
STATUS TAB .....	16-2
PROBLEMS TAB .....	16-3
TECHNICAL TAB.....	16-4
<hr/>	
<b>SECTION 17 - BLOCK DETAILS</b> .....	<b>17-1</b>
INTRODUCTION .....	17-1
SPECIFICATIONS TAB.....	17-2
Block Button .....	17-2
Tunable Blocks .....	17-4
Properties Option.....	17-5
OUTPUTS TAB .....	17-6
DESCRIPTION TAB .....	17-7
<hr/>	

## List of Figures

<i>No.</i>	<i>Title</i>	<i>Page</i>
2-1.	PC Mouse .....	2-2
2-2.	PWC90 Console System Default Window .....	2-7
2-3.	Typical Window Components .....	2-8
2-4.	Window Frame Composed of Resize Handles .....	2-10
2-5.	Distinctive Cursor Shapes for Resize Handles .....	2-10
2-6.	Cascading Menu .....	2-11
2-7.	Check Buttons .....	2-12
2-8.	Dialog Box .....	2-12
2-9.	Entry Box .....	2-13
2-10.	List Box .....	2-14
2-11.	Pop-Up Menu .....	2-14
2-12.	Pull-Down Menu .....	2-15
2-13.	Radio Buttons .....	2-16
2-14.	Toggle Buttons .....	2-16
2-15.	System Window .....	2-19
2-16.	Bailey Logo Pushbutton .....	2-19
2-17.	Mini-Alarm Window .....	2-21
2-18.	Operator Window .....	2-25
2-19.	PWC90 Console with One Operator Window .....	2-26
2-20.	PWC90 Console with Two Operator Windows .....	2-26
2-21.	PWC90 Console with Three Operator Windows .....	2-27
2-22.	PWC90 Console with Four Operator Windows .....	2-27
2-23.	System Window Menu, Windows Option Selected .....	2-28
3-1.	System Window Menu with Login/Logout Menu .....	3-2
3-2.	PWC90 Console Login Window .....	3-3
3-3.	Change Password Window .....	3-6
3-4.	Illegal Entry Pop Up Window .....	3-7
3-5.	Message Configuration Window .....	3-9
3-6.	Area Selection Window .....	3-10
3-7.	System Status Display .....	3-15
3-8.	SSD Object for a PWC90 Console .....	3-16
3-9.	Network Info Window Example .....	3-18
3-10.	Services Window Example .....	3-19
3-11.	SSD Object for a Server .....	3-20
3-12.	Device Status Window .....	3-21
3-13.	Printer Queues Control Window .....	3-22
4-1.	Operator Window Select Menu .....	4-2
4-2.	Summary Index Entry Window .....	4-2
4-3.	Select Summary Window .....	4-3
4-4.	Summary Display Example .....	4-4
4-5.	Group Information Window .....	4-5
4-6.	Group Display Configured for Four Tags .....	4-7
4-7.	Group Selection Window .....	4-8
4-8.	Tagname and Status Areas from a Group Display .....	4-9
4-9.	Value Entry Window .....	4-12
4-10.	Control Station Faceplate .....	4-16
4-11.	Remote Control Memory Faceplate .....	4-21
4-12.	Remote Manual Set Constant Faceplate .....	4-23
4-13.	Device Driver Faceplate .....	4-25
4-14.	Multi-State Device Driver Faceplate .....	4-28
4-15.	Remote Motor Control Block Faceplate .....	4-31
4-16.	Analog Faceplate .....	4-36

## List of Figures (continued)

<i>No.</i>	<i>Title</i>	<i>Page</i>
4-17.	Analog Annunciator Faceplate.....	4-37
4-18.	Digital Faceplate .....	4-38
4-19.	Digital Annunciator Faceplate .....	4-39
4-20.	Data Acquisition Analog Faceplate .....	4-40
4-21.	Data Acquisition Digital Faceplate.....	4-44
4-22.	Text String Faceplate .....	4-47
4-23.	Analog Export Faceplate .....	4-53
4-24.	Digital Export Faceplate .....	4-54
4-25.	Module Status Faceplate .....	4-55
4-26.	INFI 90 OPEN Scanner Faceplate .....	4-56
4-27.	Enter Tagname Pop-Up Window .....	4-57
4-28.	Enter Tagname Window .....	4-57
4-29.	ANALOG Module Point Display .....	4-58
4-30.	Operating Parameters Window .....	4-59
4-31.	Block Details Window .....	4-60
5-1.	Log Print Window .....	5-2
5-2.	Print Log Window (Event Logs) .....	5-3
6-1.	Selecting the Trend Option.....	6-2
6-2.	Trend Index Entry Window.....	6-3
6-3.	Select Trend Window.....	6-3
6-4.	Trend Display Example .....	6-4
6-5.	Time Entry Pop up Window .....	6-7
6-6.	Compression Value Entry Window .....	6-10
6-7.	Original Waveform .....	6-12
6-8.	Compressed Waveform - 6:1 Compression .....	6-12
6-9.	Compressed Waveform - 7:1 Compression .....	6-12
6-10.	Compressed Waveform - 5:1 Compression .....	6-12
6-11.	Section Number Entry Window .....	6-15
7-1.	Typical Graphic Display .....	7-2
7-2.	Select Graphic Pop-Up Window .....	7-3
7-3.	Graphic Display with Control Pushbutton .....	7-4
7-4.	Control Window .....	7-5
7-5.	Display Vector Pushbutton .....	7-5
7-6.	Error Indicator.....	7-6
7-7.	Zoom/Pan Window .....	7-8
8-1.	Alarm Review Window .....	8-3
8-2.	Number Entry Keypad.....	8-5
8-3.	Alarm Review Filter Window.....	8-6
8-4.	Alarm Review Sort Window .....	8-9
8-5.	Display Frozen Window .....	8-10
8-6.	Tag Search Window.....	8-10
9-1.	Event Review Window .....	9-2
9-2.	Number Entry Keypad.....	9-4
9-3.	Event Review Filter Window .....	9-5
9-4.	Event Review Sort Window .....	9-6
9-5.	Display Frozen Window .....	9-7
9-6.	Event Historian Display .....	9-8
9-7.	Event Historian Filter Window.....	9-10
9-8.	Time Selection Window .....	9-11
9-9.	Print Event Log Window .....	9-15
9-10.	Printer Selection Window .....	9-16
10-1.	Message Review Window .....	10-2

## List of Figures (continued)

<i>No.</i>	<i>Title</i>	<i>Page</i>
10-2.	Number Entry Keypad .....	10-4
10-3.	Message Review Filter Window .....	10-5
10-4.	Message Review Sort Window .....	10-7
10-5.	Display Frozen Window .....	10-8
11-1.	PWC90 Utilities Menu .....	11-1
11-2.	Backup Window .....	11-4
11-3.	Backup File Selection Window .....	11-5
11-4.	Find Window .....	11-5
11-5.	PWC90 Configuration Data Window .....	11-6
11-6.	Backup Operation Window .....	11-7
11-7.	Backup Status Window .....	11-9
11-8.	Restore Operation Window .....	11-9
11-9.	File Restore Confirmation Box .....	11-10
11-10.	Restore Window .....	11-10
11-11.	Restore File Selection Window .....	11-11
11-12.	Disk File Selection window .....	11-12
11-13.	Database Maintenance Menu .....	11-14
11-14.	Manual Data Entry Window .....	11-15
11-15.	Archival Database Maintenance Window .....	11-19
11-16.	Archive Database Menu .....	11-22
11-17.	Historical Database Archive Window .....	11-23
11-18.	Database Archive Parameters Window .....	11-24
11-19.	Historical Block Archive Window .....	11-25
11-20.	Historical Block Archive Child Window .....	11-25
11-21.	Archival Database Restore Window .....	11-26
11-22.	Alarm Groups Utility Window .....	11-29
11-23.	Alarm List Window .....	11-31
11-24.	Line Pop-Up Window .....	11-31
11-25.	CRT Print Setup Window .....	11-32
11-26.	Default Quick Keys Keypad Display .....	11-35
11-27.	Quick Key Label Assignment Window .....	11-36
11-28.	Quick Key Pop-Up .....	11-37
11-29.	CRT Context Keys Keypad .....	11-40
11-30.	CRT Context Key Assignment Window .....	11-41
12-1.	Select Menu With The Printer Review Option Selected .....	12-1
12-2.	Printer Selection Window .....	12-2
12-3.	Printer Review Display .....	12-3
12-4.	Time Selection Window .....	12-5
13-1.	Operating Parameters Window .....	13-1
13-2.	INFI 90 Tab .....	13-3
13-3.	Tag Specific Tab .....	13-4
13-4.	Red Tag Tab .....	13-5
13-5.	Set Red Tag Dialog Box .....	13-5
13-6.	Substitute Dialog Box .....	13-6
14-1.	Select Query Window .....	14-1
14-2.	Tag Summaries Window .....	14-2
14-3.	Query Design Window .....	14-3
14-4.	SQL Query Window .....	14-4
14-5.	Query Results .....	14-9
15-1.	Server Diagnostics Property Sheet .....	15-1
15-2.	Message Tab .....	15-3
15-3.	Tags Tab .....	15-4

---

## List of Figures (continued)

<i>No.</i>	<i>Title</i>	<i>Page</i>
16-1.	Module Details Window .....	16-1
16-2.	Status Tab .....	16-3
16-3.	Problems Tab .....	16-3
16-4.	Technical Tab .....	16-4
17-1.	Block Details Window .....	17-1
17-2.	Block Address Dialog Box .....	17-3
17-3.	Jump History List Dialog Box .....	17-4
17-4.	Tunable Specification Dialog Box .....	17-5
17-5.	Specification Properties Dialog Box .....	17-5
17-6.	Output Tab .....	17-7
17-7.	Description Tab .....	17-8

---

## List of Tables

<i>No.</i>	<i>Title</i>	<i>Page</i>
1-1.	Reference Documents .....	1-6
1-2.	Glossary .....	1-6
2-1.	Mouse Functions .....	2-3
2-2.	Function Key Operation .....	2-4
3-1.	Access Levels .....	3-8
4-1.	Group Status Conditions .....	4-4
4-2.	Alarm Status Descriptors (Two Character) .....	4-9
4-3.	Recommended Point Format .....	4-11
4-4.	Control Tags .....	4-13
4-5.	Control Inhibit Indications (Control Tags) .....	4-13
4-6.	Station Modes .....	4-18
4-7.	RMCB Feedback Signal to Feedback Indicator Relationship .....	4-32
4-8.	Data Acquisition Tags .....	4-34
4-9.	Control Inhibit Indications (Data Acquisition Tags) .....	4-35
4-10.	DAANG Faceplate Next High and Next Low Alarm Limit Criteria .....	4-42
4-11.	Locked and Unlocked Indicators (DAANG) .....	4-43
4-12.	Locked and Unlocked Indicators (DADIG) .....	4-46
4-13.	TEXTSTR Faceplate Operating Conditions .....	4-50
9-1.	Event Historian Time Entries .....	9-11
12-1.	Time Entry .....	12-5
14-1.	Arithmetic Operators .....	14-5
14-2.	Comparison Operators .....	14-6
14-3.	Wildcard Characters .....	14-7
14-4.	Datasheet View Translation Example .....	14-9
16-1.	Module Status Bytes .....	16-4

---

## Trademarks and Registrations

---

Registrations and trademarks used in this document include:

<sup>TM</sup> Acrobat	Trademark of Adobe Systems, Incorporated.
<sup>TM</sup> @aGlance/IT	Trademark of Intuitive Technology Corporation.
® INFI 90	Registered trademark of Elsag Bailey Process Automation.
® INFI-NET	Registered trademark of Elsag Bailey Process Automation.
<sup>TM</sup> Pentium	Trademark of INTEL corporation.
<sup>TM</sup> Windows NT	Trademark of Microsoft corporation.

---

---

# SECTION 1 - INTRODUCTION

---

## *INTRODUCTION*

The Personal Work Center 90 (PWC90) is an operating station for use with INFI 90 OPEN system. This instruction describes the operations required to use a configured PWC90 console. It is designed to accomplish the following objectives:

- Provide instructions on how to perform operational tasks on the PWC90 console.
- Provide suggestions and examples for operator activities.
- Provide additional information as necessary.

The PWC90 console communicates with the INFI 90 OPEN system through an INICIO3 interface connected to the INFI-NET system.

---

## *INTENDED USER*

This instruction is intended for use by personnel engaged in operating a PWC90 console and Bailey INFI 90 OPEN equipment.

---

## *FUNCTIONAL DESCRIPTION*

The INFI 90 OPEN Strategic Enterprise Management System is a distributed process management and control system. Using a series of integrated control PCUs, the system allows monitoring and control of process variables such as flow rate, temperature, and pressure according to a control configuration that the process (system) engineer or technician defines. A PCU is any device connected for communication on the INFI-NET or Plant Loop communication highway.

Automation of most processes requires more than control at the unit operations level. The system must also include an inherent ability to provide process management functions such as scheduling and graphical presentation of plant process conditions as well as reporting functions. The PWC90 console, process control units (PCUs) and field wiring interface terminal boards form the basic building blocks of the INFI 90 OPEN distributed control system. The PWC90 console is the human interface to this system, providing the process operator, process engineer, instrument engineer and maintenance personnel with global access to all process and system parameters required by each to perform their respective tasks.

The PWC90 console operates on a personal computer hardware platform under the Windows NT environment. Using interactive process graphics the process operator can monitor and control all analog loops and digital devices interfaced to the network via PCUs.

The PWC90 console provides the engineer with an interface through which to configure and change graphic and hierarchical displays, database I/O, process control functions and sequences, log (report) formats, and security features (including access levels for operating personnel). Most changes are immediate, on line and global, requiring no compilation time before downloading and therefore no interruption of the process.

The PWC90 console provides maintenance personnel with the capability to globally monitor the operating status of any system component on the network, and to diagnose component failures from any PWC90 console.

---

### ***User Interface***

The PWC90 console provides the process operator, engineer and maintenance technician with a window based interface to both the process and the PWC90 console itself. The user interface is described in detail in [Section 2](#).

---

### ***PWC90 Console Management Features***

The PWC90 console contains many items which aid in managing use of the system. These include:

- User logins.
- Security features.
- Messages.
- Message routing.
- System status display.

These items are described in [Section 3](#).

---

### ***Hierarchical Displays***

Hierarchical displays are a set of preconfigured, network wide graphical representations emulating traditional instrument displays. A three tiered hierarchy of displays exists to provide the user easy accessibility to process information. This hierarchy consists of summary, group and point displays, which are available network wide.

A summary display provides an overview of 24 groups, arranged in six rows of four blocks. There are 128 summary displays available.

A group display provides an operation overview of four, six or eight points simultaneously. All process control actions and alarm acknowledgment for points within a group can be performed from the group display on a point by point basis.

A point display provides the most detailed information and operation functions about a single point in the hierarchical display system. From this level the operator can perform regulatory changes. Hierarchical displays are described in [Section 4](#).

---

### ***Logging***

Logs are used to collect and format data for use in reports and spreadsheet calculations. The two types of logs available on the PWC90 console include event logs and spreadsheet logs. Logs are available network wide. Logs are discussed in [Section 5](#).

---

### ***Trends***

Trend traces display the values of from one to eight points in an analog trend format similar to that presented by a conventional strip chart recorder. Three types of trend recording are provided on the PWC90 console, including current trending, historical trending and archival trending. Trend displays are available network wide. Trends are discussed in [Section 6](#).

---

### ***Graphic Displays***

Up to 1024 network wide graphic displays can be configured on the PWC90 console. A graphic display configured on any PWC90 console is distributed (when saved or installed) to all PWC90 consoles on the same network; the graphic can then be viewed on any PWC90 console. The operator may control a process by using control pushbuttons located on graphic displays. The display vector pushbutton allows the user to move quickly and easily to other graphics or displays of other types. Graphic displays, control through graphics and display vectoring are discussed in [Section 7](#).

---

### ***Process Alarms***

A process alarm is generated when a process variable is in an abnormal condition. Process alarms are displayed in the top two lines of the mini-alarm window and in the alarm review display, and are accompanied by audible alarms. Process alarms are discussed in [Section 8](#).

---

### ***Events***

System events occur when a problem or change of state is detected with the INFI 90 OPEN system, as opposed to abnormal conditions, problems, or changes of state associated with

the process which is being monitored. System event messages are displayed in the third line of the mini-alarm window, the event review display, and the event historian. System events are discussed in [Section 9](#).

---

### ***Message Review***

Operator messages are used to provide the operator with information and instructions for performing actions, and can be generated from any PWC90 console. Operator messages are displayed in the fourth line of the mini-alarm window and in the message review display, and can be accompanied by an audible alarm. Message review is discussed in [Section 10](#).

---

### ***PWC90 Console Utilities***

A number of useful maintenance and information management functions are provided as PWC90 console utilities. Utilities discussed in this operator's instruction include:

- Alarm groups test utility.
- CRT print.
- Release all configuration locks.
- Display center help.
- User help.
- Quick keys.
- CRT context keys.

These utilities are discussed in [Section 11](#).

---

### ***Printer Review***

Messages which have been sent to a printer or to a file can be displayed using the printer review display. Printer review is discussed in [Section 12](#).

---

### ***Operating Parameters***

The operating parameters application allows the user to monitor and change the status of tags maintained by the server. Red tagging capability is also maintained in this application. Operation parameters is discussed in [Section 13](#).

---

### ***Tag Summaries***

The tag summaries application provides an interface for querying tag information and producing tag summary reports. The query can be viewed in one of three ways: design view, SQL view, or datasheet view. [Section 14](#) explains the use of the tag summaries application.

---

### Server Diagnostics

The server diagnostics application provides detailed information about the working status of a selected PWC90 server. The application supports possible server changes and can be started even if the server is not running. Server diagnostics is discussed in [Section 15](#).

---

### Module Details

The module details application provides detailed information about the operational status of a selected INFI 90 OPEN module. [Section 16](#) explains the use of the module details application.

---

### Block Details

The block details function provides detailed information about a selected function (program) block in the processor modules of the PCUs. This application also permits the tuning of tunable blocks to adjust the process control. Block details is discussed in [Section 17](#).

---

## DOCUMENT CONVENTIONS

This document uses standard text conventions throughout to represent keys, user data inputs, and display items:

**KEY** Identifies a keyboard key.

Example: Press **ENTER**.

**USER INPUT** Indicates a fixed input that must be entered exactly as shown.

Example: Type **FIRMWARE**.

*Display item* Any item that displays in the screen appears as italic text.

Example: *Restore File button*  
*User Administrator logged in on PWC1*

**File name** Any file names and file extensions appear in bold italics.

Example: ***query1.qry***

---

## REFERENCE DOCUMENTS

This Instruction provides information only for the operation of the PWC90 console. Table [1-1](#) list additional documents that relate to the operation of the INFI90 OPEN system.

Table 1-1. Reference Documents

Number	Document Title
WBPEEU1220762A0	Personal Work Center 90 Configuration Instruction
WBPEEU1220763A0	Personal Work Center 90 Installation and Setup Instruction
I-E96-200	Function Code Application Manual

## GLOSSARY OF TERMS AND ABBREVIATIONS

This glossary provides definition for terms used in the **Personal Work Center 90 Operation** instruction. Where alternate usage is defined in the glossary, the first listed term is considered the preferred usage.

Table 1-2. Glossary

Term	Definition
Atom	A single data element in the global database. Atoms can exist in various forms, including (but not limited to) a single bit (e.g., Auto/Manual), a floating point number, a tagname or a multi-character legend; there is no predefined limit to the size of an atom. See also Module.
GMS (Graphical Modeling System)	A PWC90 application program licensed from SL Corporation. GMS is used to create PWC90 displays. Each PWC90 console incorporates an RT (runtime) license to utilize GMS models.
ISO (International Standardization Organization)	A worldwide federation of national member bodies providing guidelines for the development of standards.
ISO9000	A set of ISO standards which provide guidelines for rationalization of the many and various internal practices used by vendor companies to insure the absence of deficiencies in the company's internal organizational systems, practices, and specifications used to design and produce a product or service.
Mini-Alarm Window	The Mini-Alarm Window is located to the right of the system window on the PWC90 screen. It automatically appears upon system start-up and is visible at all times. The mini-alarm window provides a title bar, an alarm display area, an event display area, alarm acknowledge buttons to acknowledge alarms and events, and a filter button and more alarms indicator.
Node	A point of interconnection to a network. On the INFINET all INICI, CIU, or NIS/NPM connections are considered nodes, and on the ethernet all PWC90 consoles and servers are nodes.
Operator Window	Located on the PWC90 screen below the system window and mini-alarm window, the operator window provides the operator interface to the process, and displays program output from operator window applications such as hierarchical displays, trends, graphics, alarm review, etc. The operator window is composed of a title bar, a menu bar, and a display area. Up to four operator windows may be present simultaneously on a PWC90 console.
Parent Window	The top level window placed on the screen when a new application is started. When a parent window is closed (removed from display), all child windows are also closed. The PWC90 keyboard (A/N keys, mouse, etc.) is focused on one parent window, with the parent window border indicating the focus.

Table 1-2. Glossary (continued)

Term	Definition
Personal Work Center 90 (PWC90)	The Personal Work Center 90 is a Windows NT-based system which supports the PWC90 software.
PIC (Personality Integrated Circuit)	A hardware key associated with software licensing.
Process Area	A functional partition of the process. A tag is assigned to and often located in a particular Process Area. PWC90 functions can be assigned by Area.
PWC90	See Personal Work Center 90.
Quick Key	A menu button on the PWC90 screen which, when pressed, provides the user with the ability to vector directly to one of 64 possible displays.
SL-GMS (SL Corporation Graphical Modeling System)	See GMS.
Software License	A software license conveys to the purchaser the right to use a defined software product. A license for some software (i.e. SL-GMS/RT) is incorporated in the purchase price of a INFI 90 OPEN product. Other software licenses (i.e., for SL-GMS/DEV) must be purchased separately. Local software products are licensed for a specific platform, while Global Application products are licensed for network wide usage. Software licenses are enforced with PICs and with a software licensing manager program.
System Window	A small window located at the top left corner of the PWC90 screen. It appears automatically upon system start-up, and is visible at all times. The system window provides a date/time indicator and a menu button for access to other system features and utilities.

---

## SECTION 2 - PWC90 CONSOLE USER INTERFACE

---

### *INTRODUCTION*

The PWC90 software is installed on a supported personal computer (PC). The PWC90 console graphical user interface (GUI) is based on Windows NT. This technology allows the user to work simultaneously with multiple application programs, each within a separate window.

The PWC90 console user interface provides:

- Window management.
- One system window.
- One mini-alarm window.
- Up to four operator windows.

The function and use of these user interface elements are explained in this section.

---

### *PWC90 CONSOLE APPEARANCE*

Visually, the graphical user interface is presented in a window based format. Multiple windows can be opened simultaneously, allowing the user to view up to four different process displays at once.

The window format provides a three dimensional (3 D) appearance to such screen objects as buttons, scrollbars and window frames. For example, graphical buttons displayed on the screen are shaded to appear in either the raised (out) position or pressed (in) position. A pointing device, such as a mouse or trackball (refer to **INPUT DEVICES** in this section), is used to position the screen pointer on a 3 D button on the screen, and the select button on the mouse or trackball (left button) is pressed and released, or clicked. In this manner, clicking on a graphical button that is out changes the shading so that it appears to be pressed in, and vice versa.

---

### *INPUT DEVICES*

Operation of PWC90 console functions is most conveniently accomplished by the use of a pointing device, such as a mouse or trackball. Although it is possible to access all displays and all menu bar choices via the keyboard, a pointing device is required to access the object-oriented graphical functions, such as pushbuttons, toggle buttons, radio buttons and so on.

(**PWC90 CONSOLE DISPLAY** in this section provides a detailed discussion of these items.)

**NOTE:** While it is possible to perform all process operation functions at the PC using only a pointing device, a keyboard is required for some configuration activities.

---

### Pointing Devices

The pointer cursor (also known as the mouse cursor) is a small, mobile image on the screen, which is controlled by a pointing device such as a mouse or trackball. In this instruction, the term pointer refers to the pointer cursor, while the term mouse refers to the pointing device. The pointing device is physically and electrically a separate device; it can be used next to the keyboard, but this is not a requirement.

**Mouse** The standard pointing device on the PC is a three button mouse as shown in Figure 2-1.

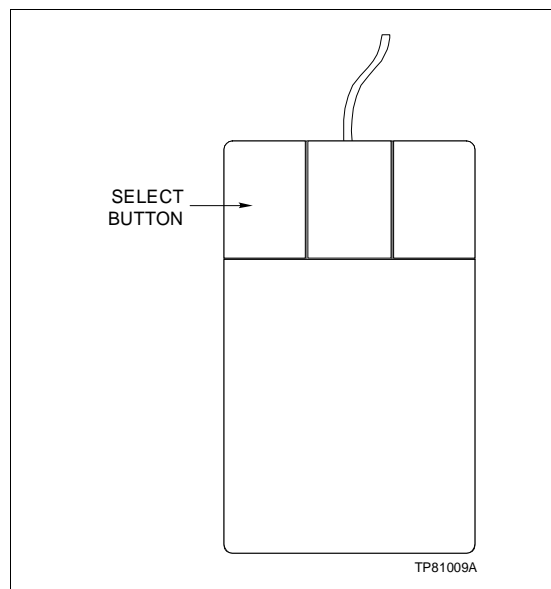

Figure 2-1. PC Mouse

When moved on the surface of a desk or table the mouse allows the user to perform the following actions:

- Pointing** Sliding the mouse on the desktop or tabletop to position the pointer on an object on the screen.
- Pressing** Holding down a mouse button.
- Clicking** Pressing and releasing a mouse button without moving the pointer.
- Double Clicking** Clicking a mouse button twice in rapid succession.

**Dragging** Pressing a mouse button while moving the pointer.

On the PC mouse, the left mouse button functions as the select button, unless otherwise indicated. The mouse and select button can be used together to perform actions as described in Table 2-1.

**NOTE:** While generally only the left button is used with PWC90 software, all three mouse buttons are supported for compatibility with possible usage in third party software.

Table 2-1. Mouse Functions

Left Button Action	Desired Action	Example
Press the left button.	Initiate a drag operation.	Pressing the left button with the pointer on a window menu button on an operator window frame causes the window menu to be displayed.
Dragging the left button (i.e., drag the mouse while holding down the left button).	Perform a drag function, such as moving a window, resizing a window, or browsing a menu.	Pointing to the title area of an operator window and dragging the mouse with the left button pressed performs a move operation.
Release the left button.	Complete an action started with a press and drag of the left button.	Releasing the left button after dragging the button on a title bar ends the move operation.
Click the left button.	Left an object or action.	Clicking the Left button with the pointer positioned on the maximize button on a graphic configuration window frame of original size causes the window to be maximized to fill the available area of the screen.
Double click the left button.	Use a shortcut for performing a default action associated with an object.	Double clicking on an item in a scrolled list will cause the item to be selected.

To select menu items, either of two methods can be used. Position the pointer on a menu item and click the left mouse button, repeating this action for each menu item selected from any cascading menus. Alternatively, position the pointer on the desired menu item, then press the left mouse button while dragging the pointer to the next menu item.

---

**Keyboard**

The IBM AT compatible 101 key keyboard provides the function keys (F1) through (F12) and Alt-function key combinations. They are used to perform the functions listed in Table 2-2. Where an Alt-function key combination is specified, press and hold Alt simultaneously with the specified function key.

Table 2-2. Function Key Operation

Function Key	Display Function
F1	Graphic
ALT-F1	Network Status Display
F2	Summary
F3	Group
F4	Point Display
F5	Quick Keys
F6	Trend
F7	Alarm Review
ALT-F7	Print Log
F8	Event Review
ALT-F8	Arrange Windows
F9	Display Forward
ALT-F9	Alarm Ack
F10	Display Backward
ALT-F10	Window Acknowledge
F11	Not Used
ALT-F11	Silence
F12	Help

**F1 Graphic** Displays the graphic selection dialog box. Enter the number of the graphic (1 - 1024), then click on *OK* (or press **Return** on the keyboard) to display a specific graphic. To view an index list of all graphics which have been defined, click on *List* located at the bottom of the graphic selection dialog box.

**F2 Summary** Displays the summary selection dialog box. Enter the number of the summary (1 - 128) to be displayed, then click on *OK* in the dialog box (or press **Return** on the keyboard). To view an index list of all summaries which have been defined, click on *List* located at the bottom of the summary selection dialog box.

After viewing a point or group display called up via the hierarchy (i.e., the user first called up a summary, then a group from that summary, then a point from that group), recall the last summary displayed by pressing **F2**. This is the only instance in which the system will automatically vector to the last summary display shown.

**F3 Group** Displays the group selection dialog box. Enter the summary number (1-128) and group number (1-24) for the group to be displayed (separated by a period [.]), then click on *OK* in the dialog box (or press **Return** on the keyboard). To view an index list of all groups which have been defined, click on *List* located at the bottom of the group selection dialog box.

After viewing a point display called up via the hierarchy (i.e., first a group was called up, then a point from that group), the last group displayed can be recalled by pressing **F3**. This is the only instance in which the system will automatically vector to the last group display shown.

- F4 Point** Displays the point dialog box. Enter the tagname of the point to be displayed (up to 16 alphanumeric characters), then click on *OK* in the dialog box (or press **Return** on the keyboard).
- F5 Quick** Calls up the quick key keypad for the operator window which has keyboard focus.
- F6 Trend** Calls up the trend selection dialog box. Enter the number of the Trend (1 - 512) to be displayed, then click on *OK* in the dialog box (or press **Return** on the keyboard). To view an index list of all trends which have been defined, click on *List* located at the bottom of the trend selection dialog box.
- F7 Alarm Review** Shows the alarm review display, a list of all active process alarms captured on the system. The order in which process alarms are listed on the alarm review display is the same as that used in the mini-alarm window. The configurer can elect to display either the newest or oldest high priority alarm, and this can depend on whether or not unacknowledged alarms exist.
- If more than one page of process alarms exists, use the scrollbar or **Pg Up** and **Pg Dn** to view the additional alarms.
- F8 Event Review** Shows the event review display, a list of all active process alarms and system events captured on the system.
- If more than one page of system alarms exists, use the scrollbar or **Pg Up** and **Pg Dn** to view the additional alarms.
- F9 Display Forward** Use **F9** and **F10** to move forward and backward between the last ten displays which have appeared in the window with keyboard focus, regardless of display type. These keys correspond to the *Display Forward* and *Display Back* functions available from the *Window* option on the menu bar of each operator window.

Changing displays by any means other than *Display Forward* and *Display Back* will affect the list which keeps track of the last ten displays viewed. For example, if the user is on display *n* (where *n* is greater than one and less than ten) and selects another display by any means other than *Display Forward* or *Display Back*, then displays *n+1* through ten will be discarded,

and the new display will be placed at the end of the list (i.e., it becomes display  $n + 1$ ).

**NOTE:** Use **F9** display forward and **F10** display back function keys to move through displays of different types, which have already appeared on the screen; these keys should not be confused with **Pg Up** and **Pg Dn**, which are used to move through different pages of one display type.

<b>F10 Display Back</b>	See <i>Display Forward</i> .
<b>F12 Help</b>	Calls up context sensitive <i>Help</i> displays.
<b>Alt-F1 System Status</b>	Displays the status of the nodes on the INFI 90 OPEN System.
<b>Alt-F7 Print Log</b>	Displays the <i>Log Print</i> window. This window provides access to lists of summary logs, event logs and spreadsheet logs, and also provides access to the printing mechanism for the logs which appear in these lists.
<b>Alt-F8 Arrange Windows</b>	Returns all windows to their original size and location, and move the pointer to the upper left hand corner of the screen.
<b>ALT-F9 Alarm Ack</b>	Acknowledges the alarm in the top line of the mini-alarm window, and silences the audible alarm.
<b>ALT-F10 Window Ack</b>	Acknowledges all alarms associated with the page on display. This button is functional only on point and group displays, alarm and event review displays and on graphic displays. Use of this button is equivalent to clicking the <i>Acknowledge</i> item on the <i>Window</i> menu of the operator window.
<b>ALT-F11 Silence</b>	Silences the audible alarm. Does not perform alarm acknowledgment.

---

## PWC90 CONSOLE DISPLAY

The PWC90 console provides a window based user interface to the process. A window is a rectangular portion of the screen, which has a background color and a border. Windows contain displays which can be accessed by the user via the input devices available on the system. The standard input devices are the keyboard and the mouse. A trackball is available as an optional replacement for the mouse.

Three key types of windows which appear on the PWC90 console are the system window, the mini-alarm window and operator windows. One system window, one mini-alarm window, and up to four operator windows can appear on the display. Each of these window types has a different purpose and appearance.

The PWC90 console default display consists of the system window, the mini-alarm window and one operator window, as shown in Figure 2-2. This default window configuration is used

at system startup. If no other default window configuration has been configured, it is also used when an operator logs out.

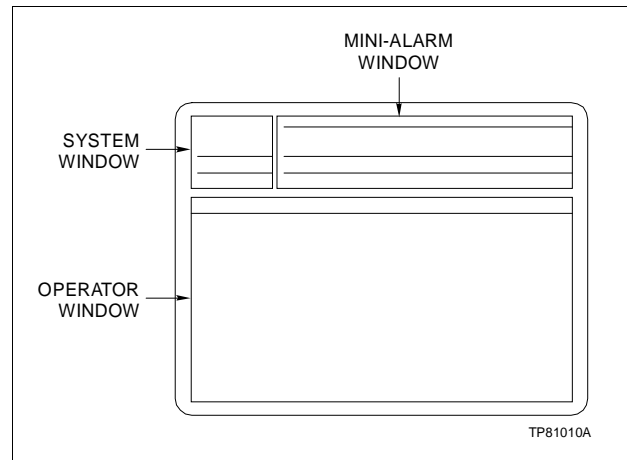

Figure 2-2. PWC90 Console System Default Window

---

**Description of Window Operations - General**

The system window and mini-alarm window are fixed in size and location, and cannot be altered. Other types of windows, including (but not limited to) operator windows, help displays and graphic configuration displays, contain elements and features which allow the user to manually perform window management operations, such as changing the size and shape of the window, moving the window and closing the window. Other window operations include making selections from the window, viewing selection lists and text.

---

**TYPICAL WINDOW COMPONENTS**

Windows are generally composed of three main areas (Figure 2-3):

- Title bar.
- Menu bar.
- Display area.

The title bar contains information which identifies the window. In the case of an operator window, it contains the number of the operator window and type of process display, if any, running in the window. In the case of a child window, the title bar contains the number of the parent window. In Figure 2-3, the title bar identifies the window as *Operator Window #1*, and reports that the display area contains *SUMMARY 3* (not shown). At the left end of the title bar is a small square button which contains a horizontal bar; this is known as the window menu button, which provides access to the window control functions move, resize, and minimize.

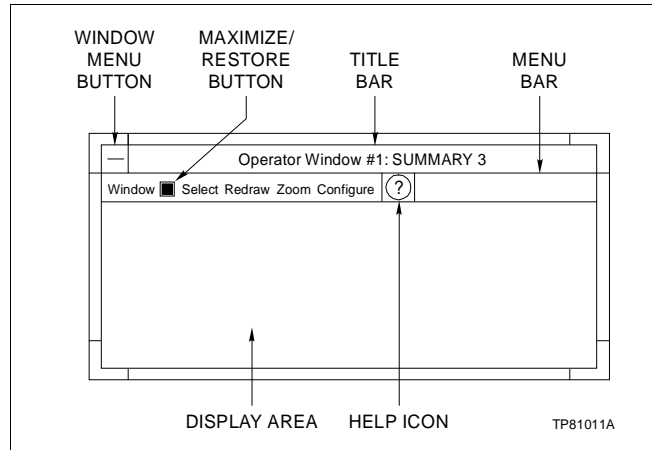

Figure 2-3. Typical Window Components

The menu bar contains the titles of any pull-down menus and functions available for the window. In Figure 2-3, for example, the *Window* and *Select* options cause pull-down menus to appear, while the *Redraw* option performs a function (redrawing the screen).

The display area is used to contain the display for the process interface feature the user wishes to access (i.e., summaries, points, groups, graphics, and so on).

The Help icon on the menu bar allows the user to access on line files of the Operation and the Configuration instructions.

The frames of some windows contain features which allow the user to change the size of the window. In this case the sides and corners of the frame function as *resize handles*, which allow the user to change the size of the window in one or two directions. **RESIZE** in this section provides details on use of resize handles.

---

### **DIRECTING INPUT TO A WINDOW - KEYBOARD FOCUS**

Keystrokes from the keyboard go to the window with keyboard focus. To achieve keyboard focus using the mouse or trackball, position the pointer somewhere on the window which is to receive keyboard input, then click the left mouse button to select that window. The window border and title bar will change color to indicate that it is the window with keyboard focus. Only one window can have keyboard focus at any given time, although it is possible for no window to have keyboard focus. A single click using the mouse (or trackball) can be used to select objects in a window which does not have keyboard focus; after the click, the window will have keyboard focus.

Using the keyboard, keyboard focus can be achieved by pressing **Alt** and **Tab** simultaneously. The **Alt-Tab** combination can

be used to change keyboard focus to the other windows on the screen, including the system window and mini-alarm window. The **Alt-Tab** combination routes keyboard focus to the previously selected window(s), moving the keyboard focus back through the order in which they were selected. The combination **Alt-Shift-Tab** can also be used to change keyboard focus; this combination is the opposite of **Alt-Tab** and can be used to reverse the order of window selection for keyboard focus.

---

### **MOVE**

Once opened, an operator window can be moved to any location on the screen. It is recommended that windows be placed in such a manner that they do not cover the system window or mini-alarm window, although the system will allow these windows to be covered. When a new alarm is displayed, the mini-alarm window will pop to the top layer of the display.

Windows can be moved by positioning the pointer on the title bar of the window to be moved, then press the left mouse button. Drag the mouse to move the bounding box to the desired location and release the left mouse button. The window will be moved to that location.

The system window and mini-alarm window cannot be moved.

---

### **RESIZE**

Windows which have resize handles (located on the frame of the window) can be shrunk or stretched (Figure 2-4). Window size can be changed vertically, horizontally or diagonally (in two directions). The display which appears in the window is automatically adjusted to the new window size.

Windows which can be resized have frames which are actually composed of eight separate pieces, each of which is a resize handle. These pieces include the top, bottom, left side and right sides of the frame, which allow vertical and horizontal movement. The upper right corner, upper left corner, lower right corner and lower left corner allow diagonal (two dimensional) resizing.

To resize an operator window using the resize handles, position the pointer on the desired portion of the operator window frame and press the left mouse button. The pointer will assume the distinctive cursor shape for that particular resize handle, as shown in Figure 2-5.

Still pressing the left mouse button, drag the mouse to reposition the corner or edge of the window. Release the mouse button when the corner or edge is in the desired location.

The system window and mini-alarm window cannot be resized.

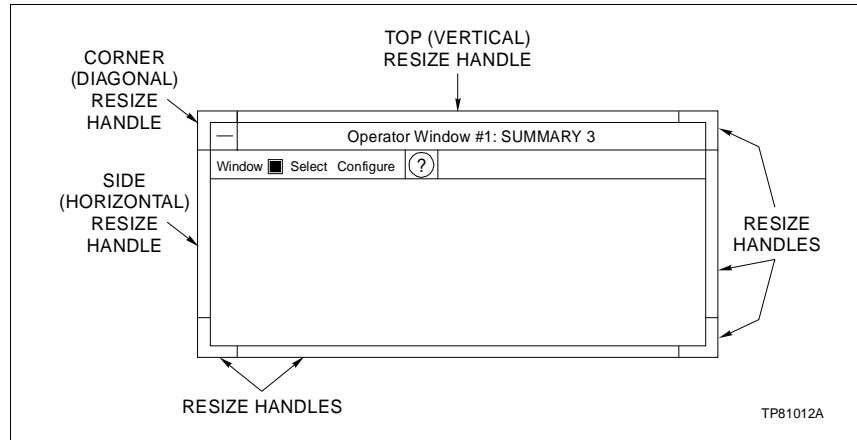

Figure 2-4. Window Frame Composed of Resize Handles

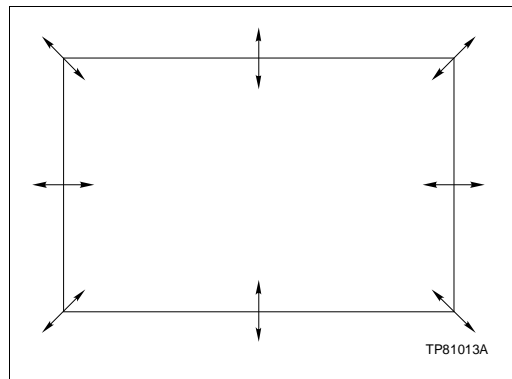

Figure 2-5. Distinctive Cursor Shapes for Resize Handles

---

### MAXIMIZE

The *Maximize* option causes a window to expand to fill the entire work area below the system and mini-alarm windows. To *Maximize* a window, position the pointer on the *Maximize* button (Figure 2-3) on the operator window menu bar and click the left mouse button; the window will be maximized to fill the entire area below the system and mini-alarm windows.

Some types of windows (i.e., the graphics configuration window) contain a *Maximize* button located at the right end of the title bar, instead of on the menu bar. Position the pointer on the *Maximize* button and click the left mouse button. The window will be maximized to fill the entire screen. The system window and mini-alarm window are covered by windows maximized via this type of *Maximize* button.

---

### RESTORE

The mini-alarm window will move to the top of the stack when a new alarm is displayed.

If a window has been maximized, it can be returned to its original size by placing the pointer on the *Maximize* button and clicking the left mouse button.

**NOTE:** If an operator window has been maximized and then resized, clicking on the *Maximize* button a second time will only be used to restore the window to the size determined by the resize operation. The window's original size, prior to being maximized, is lost.

---

### OTHER WINDOW FEATURES

Windows can contain other features such as pushbuttons, toggle buttons and scroll bars. These special features are described below. Although the system window and mini-alarm window do not contain all of these features, many of the functions available from these windows produce offspring (also known as child windows or subwindows) which use them.

A cascading menu is a submenu, which provides selections that amplify the parent selection on a pull-down or pop-up menu (Figure 2-6).

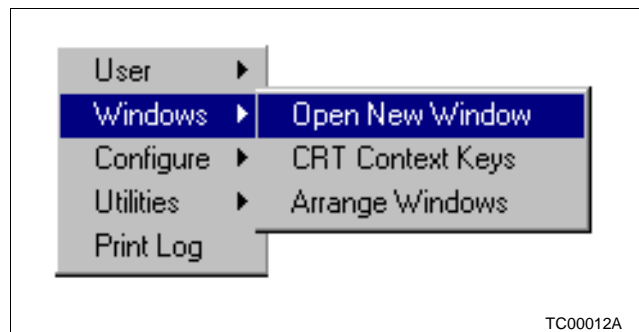

Figure 2-6. Cascading Menu

A check button is a type of graphic control button used to select settings that are not mutually exclusive. The visual cue to indicate that an item has been selected consists of a button which is filled in or appears to be pressed in (Figure 2-7).

A dialog box is a window which displays as a result of a user action and contains graphical controls such as toggle buttons, radio buttons or other pushbuttons (Figure 2-8).

An entry box is an area, usually located in a pop-up window, which allows the user to enter and edit text. The text can be a simple string, such as a key label, or multiple lines, such as user help text (Figure 2-9).

When a text entry box has keyboard focus, a blinking vertical bar cursor appears in the box. Each keystroke from the keyboard will add a character to the right of the cursor. Press **Delete** to delete the character to the right of the cursor. Press

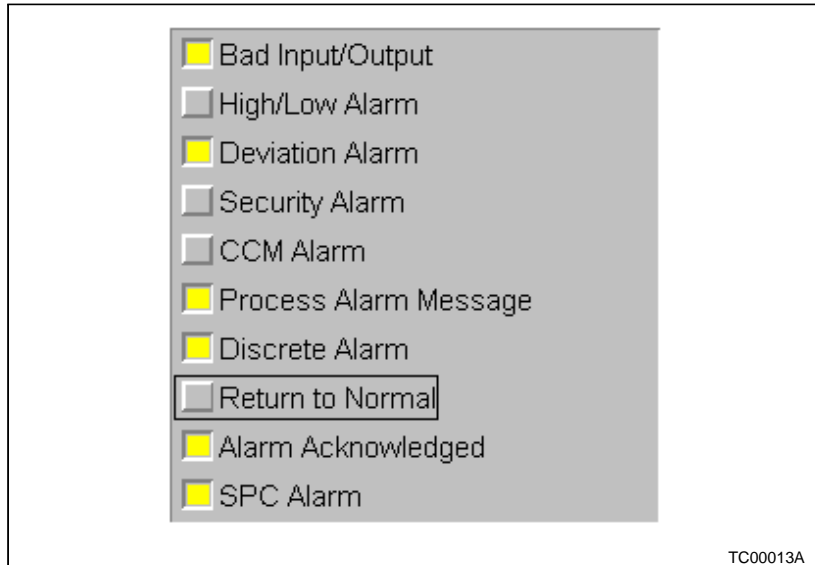

Figure 2-7. Check Buttons

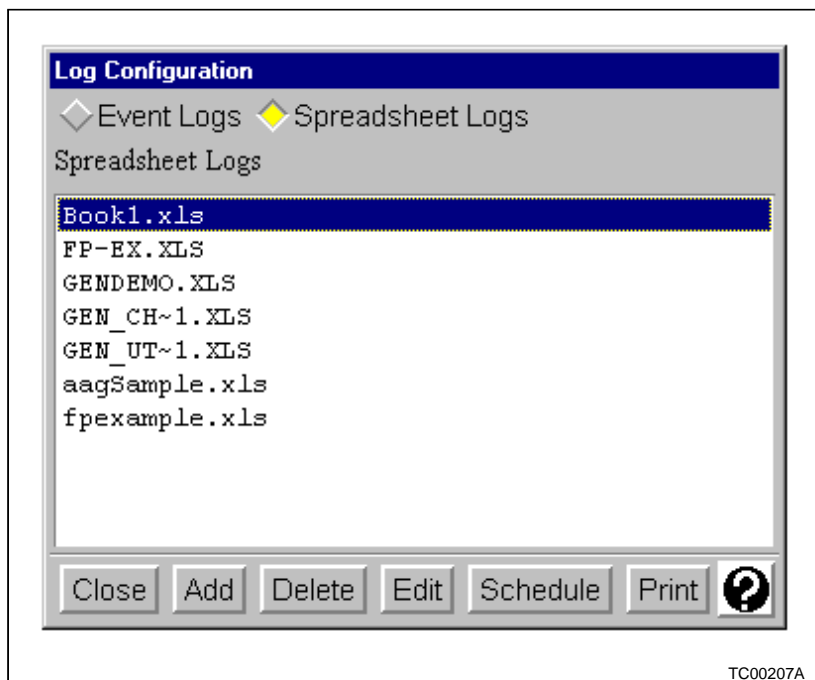

Figure 2-8. Dialog Box

**Backspace** to delete the character to the left of the cursor. The arrow keys can move the cursor without modifying text. The cursor can also be moved using the mouse, by clicking on any character in the entry box.

More complex editing is accomplished by using the mouse to select portions of the text, as described below:

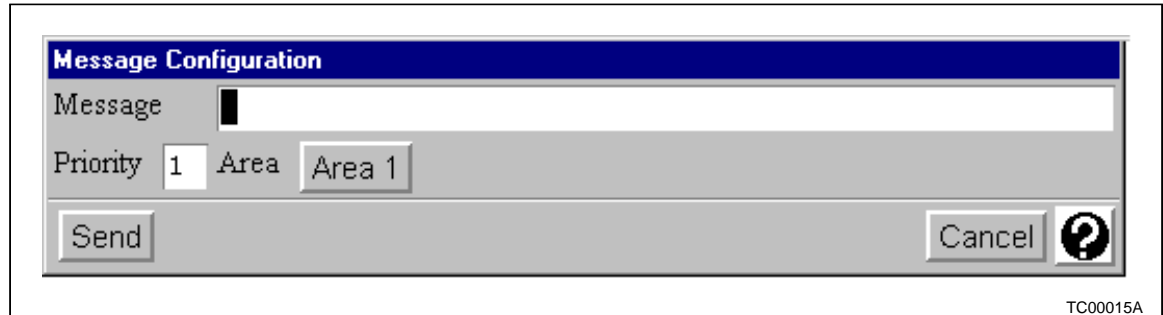

Figure 2-9. Entry Box

- To edit a single word, position the vertical bar cursor before the first letter of the word, or anywhere within the word, and then double click the left mouse button. The word will be highlighted. Enter the new text to replace the old word, or press **Delete** to remove the word.
- To edit an entire line of text, triple click the left mouse button; the entire line of text will be highlighted. Note that the entire line is highlighted regardless of the initial position of the vertical bar cursor on the line. With the line of text highlighted, enter the new text to replace the old line, or press **Delete** to remove the line.
- If the text consists of more than one line (i.e., an operator message), and all of the text is to be edited or removed, quadruple click the left mouse button. All of the text will be highlighted. Note that all of the text is highlighted regardless of the initial position of the vertical bar cursor within the text. With the text highlighted, simply enter the new text to replace the old, or press **Delete** to remove all of the text.
- To edit multiple lines (or multiple words) of text, highlight the desired area by dragging the vertical bar cursor to select the desired text. Begin by moving the pointer to the starting point in the text entry box, then pressing and holding the left mouse button. This action positions the vertical bar cursor at that point. Next, drag the vertical bar cursor along the line (or lines) to be removed. When you reach the end of the text to be edited, release the left mouse button; the selected text is highlighted. With the text highlighted, simply enter the new text to replace the old, or press **Delete** to remove the selected text.
- To add text to the currently selected (highlighted) text (known as the current primary selection), move the pointer to the position in the text that corresponds to the last character you want to add, then simultaneously press **Shift** and left mouse button. Text can be added in front of or after the current primary selection. The selected text can then be edited or deleted as described above.

A list box is an area within a window which provides the user with a scrollable list of options from which to choose. An example of a list box is the list of alarm priority colors, shown in Figure 2-10. To select an item from the list in the list box, position the pointer on that item and click the left mouse button.

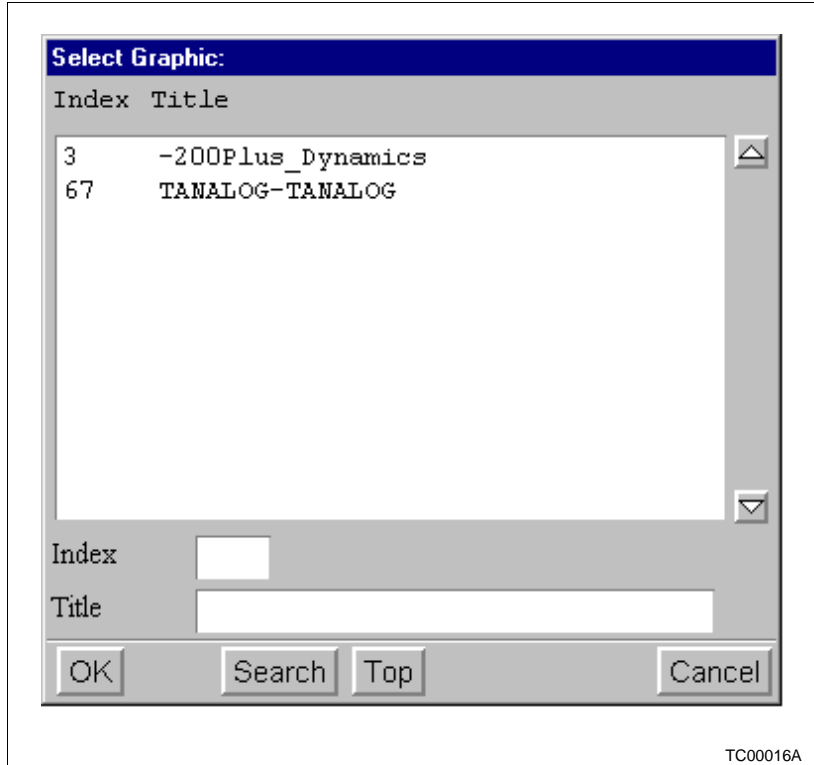

Figure 2-10. List Box

A pop-up menu is a menu which provides no visual clue to its presence, but simply pops up when a particular action is performed (Figure 2-11).

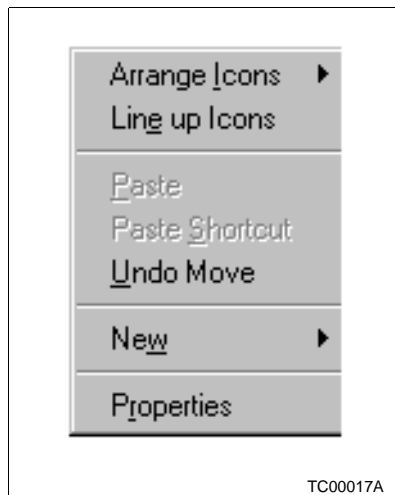

Figure 2-11. Pop-Up Menu

A pull-down menu is a menu which is pulled down from the window's menu bar (Figure 2-12).

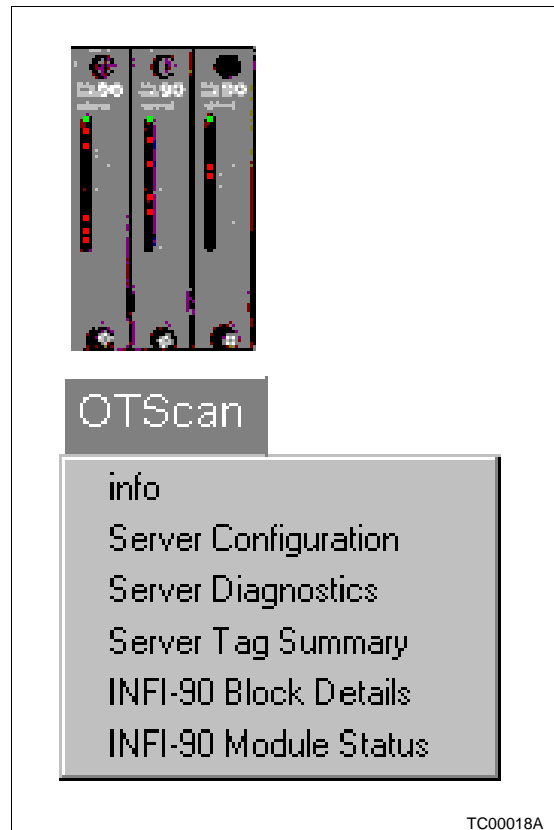

Figure 2-12. Pull-Down Menu

A pushbutton is an area of the screen surrounded by a border shadow. *Close* in figure Figure 2-8 is an example of a push button. When the pushbutton is selected, the shadow moves to give the illusion that the pushbutton has been pressed in. When the pushbutton is unselected, the shadow moves to give the appearance that the pushbutton has been released. Pushbuttons can contain text, numbers, colors or symbols such as directional arrows. Pushbuttons which appear frequently are the *Ok*, *Cancel*, *Close*, *Apply* and *Default* pushbuttons. Exit a window without committing any of the selections made in the window by clicking *Cancel*. When there is no data to save, click on *Close* to close the window. Clicking *OK* completes a selection operation, saving any changes made via the window, and exiting from that window. Clicking *Apply* also completes a selection operation, but the window containing the button remains open. Clicking on the *Default* key causes all parameters in the window to be reset to their default settings.

A scroll bar is a feature used to view data that is too large to be viewed in its entirety in the associated work area. A scroll bar can be seen in Figure 2-10. (The work area typically contains data such as a list or block of text.) A scroll bar consists of two

arrows pointing in opposite directions at each end of a small rectangle. The rectangle is called the scroll region. A smaller rectangle called the slider is located within the scroll region. The ratio of slider size to the scroll region size corresponds to the relationship between the visible data and the total amount of data. For example, if fifty percent of the data is visible in the work area, the slider will fill fifty percent of the scroll region. Scroll bars can be located both horizontally and vertically. Horizontal scroll bars are located at the bottom edge of a work area; vertical scroll bars appear at the right edge. To scroll through the data in the work area, position the pointer on the slider, press the left mouse button, and drag the slider through the scroll region. Release the left mouse button when the desired data is in the work area.

A radio button is a graphic control button on a window display which simulates the buttons found on a car radio (Figure 2-13). Each button represents a mutually exclusive selection. radio buttons are typically used to set states or modes.

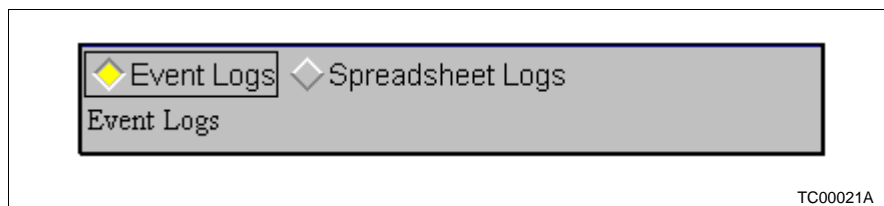

Figure 2-13. Radio Buttons

A toggle button is a square shaped box located to the left of text or graphics items (Figure 2-14). These items can be selected or deselected using the toggle button. Select (or unselect) the item by positioning the pointer inside the toggle button and click the left mouse button. The toggle button is then shaded to appear pressed in, indicating that it has been selected, or is shaded to appear in the out position to indicate it has been unselected.

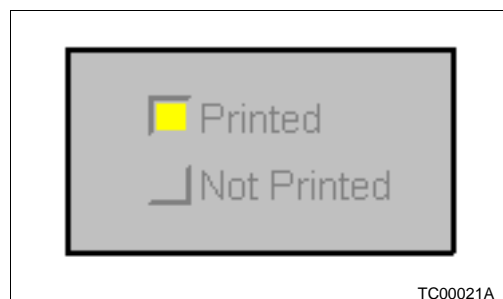

Figure 2-14. Toggle Buttons

---

## KEYBOARD TRAVERSAL

Keyboard actions are available which can be substituted for mouse movement and selection during configuration opera-

tions. This technique is called keyboard traversal and includes the following operations:

- Calling up displays via function keys.
- Selecting items from menus using mnemonic keys.
- Using arrow keys to highlight menu items for selection.
- Changing keyboard focus between windows.
- Changing keyboard focus between parent and child windows.

**NOTE:** The keyboard traversal feature can not be used on any part of the process displays for trend, point, group or graphic displays (i.e., trace buttons on a trend display, or slew buttons on a point display); these displays require use of the mouse. Keyboard traversal can be used during configuration of these displays, however.

---

### ***Mnemonic Menu Keys***

The selections which appear on a window's menu bar vary, depending on the type of display contained in the window. The W, S, R, Z and C are capitalized on the trend display menu bar, as shown in Figure 2-3. The capitalized letter is the mnemonic letter for the selection.

Pressing the mnemonic letter key (on the keyboard) and the **Alt** key simultaneously causes the desired menu to be displayed. This action affects the window with keyboard focus. The first available selection on the menu is automatically highlighted.

If no menu is attached to the menu bar item, the function it represents will be invoked; i.e., pressing **Alt-R** when a window containing a trend display has keyboard focus, will cause the display to be redrawn.

---

### ***Menu Item Selection via Arrow Keys***

Once a menu has been displayed, the arrow keys can be used to move around the menu or to move to cascading menus. Once the desired item is highlighted, press **Enter** to select the item.

To remove the menu from the display without selecting an item, move the pointer off the menu and click the left mouse button, or press **Esc**.

---

### ***Changing Windows via the Keyboard***

Using the PWC90 console keyboard, keyboard focus can be achieved by pressing **Alt** and **Tab** simultaneously. The **Alt-Tab**

combination can be used to change keyboard focus to the other windows on the screen, including the system window and mini-alarm window. The **Alt-Tab** combination routes keyboard focus to the previously selected window(s), moving the keyboard focus back through the order in which they were selected. The combination **Alt-Shift-Tab** can also be used to change keyboard focus; this combination is the opposite of **Alt-Tab**, and can be used to reverse the order of window selection for keyboard focus.

The **Alt-Tab** combination treats a window and its pop-up offspring as a single unit.

---

### **Using Pop-Up Windows via the Keyboard**

To change focus between a window and its pop-up offspring, press **Cntrl** and **Tab** simultaneously. If focus is transferred from a modal window (which requires user input) to its offspring, the **Cntrl-Tab** combination causes focus to subsequently be moved from area to area within the current pop-up window. This type of focus (denoted by a heavy black outline) shifts to buttons and entry boxes within a tab group. (The arrow keys can also be used to shift focus between items in a tab group.) To change focus between different tab groups within a pop-up window, press **Tab**. To select a button or submit text entered in an entry box, press **Enter**.

---

### **System Window**

The system window is a small window located in the top left corner of PC screen, immediately to the left of the mini-alarm window (Figure 2-15). The system window appears automatically upon system startup and is visible at all times, unless it is intentionally covered by the operator or is temporarily covered by a pop-up window. The system window cannot be moved, closed, or resized. Normal window operations such as opening an operator window or maximizing a window will not cover or overlap the system window.

---

### **COMPONENTS**

The system window is composed of three main parts:

- Bailey logo pushbutton.
- Date and time indicator.
- *Menu* pushbutton and Help icon.

The Bailey logo pushbutton identifies the system as a Bailey product; pressing the button causes the PWC90 software version number to be displayed (Figure 2-16).

The date and time indicator continuously displays the date and time.



Figure 2-15. System Window

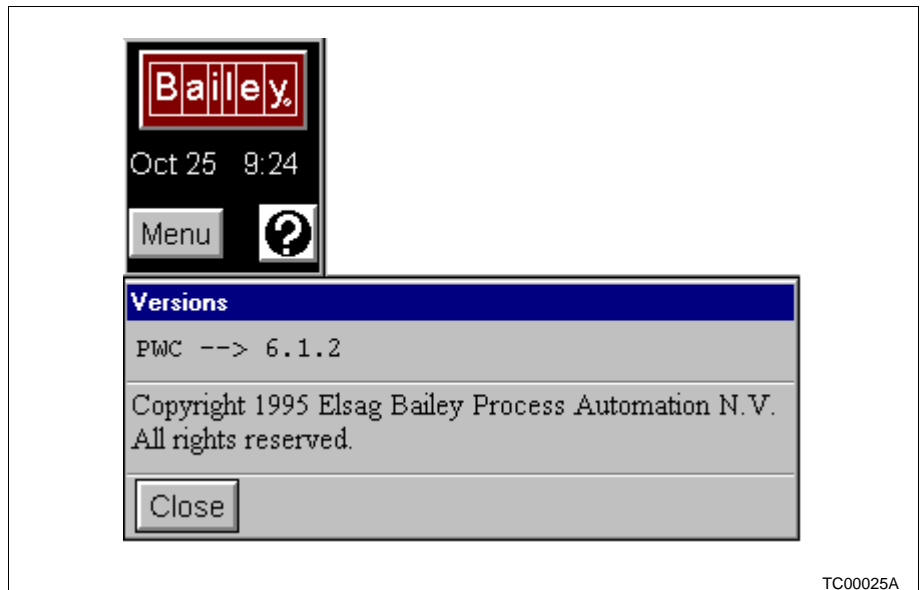

Figure 2-16. Bailey Logo Pushbutton

The menu pushbutton provides access to the system window menu functions.

---

### **MENU FUNCTIONS**

The *Menu* pushbutton on the system window provides access to configuration of PWC90 console parameters, security parameters, and network parameters.

---

### **Console Parameters**

The following PWC90 console setup parameters are available for user configuration from the system window:

- System name (title bar in mini-alarm window).
- PC network name.
- Alarm presentation on top line of mini alarm window.
- Priority color assignments.

---

**Console Security Parameters**

The following security parameters are configurable for each user logged into PWC90 console:

- Password.
- Operator access level.
- Area access.
- Priority access.
- Node access.
- Initial displays.
- 64 quick key assignments per login name (single window display).
- 16 CRT context key assignments per login name (multi window displays).
- Message filtering.

The following security parameters are configurable for a PWC90 console with no user logged in (default security):

- Operator access level.
- Area access.
- Priority access.
- Node access.
- Initial displays.
- 64 quick key assignments.
- 16 CRT context key assignments.
- Message filtering.

---

**Network Parameters**

The following network parameters allow for configuration of parameters that are global to the network:

- Alarm setup.
- Alarm vectors.
- Area names.
- Event bit names.
- Printer assignment.
- Message routing.
- Network device assignments.
- Operator window parameters.

**Mini-Alarm Window**

The mini-alarm window appears to the right of the system window on the screen (Figure 2-17). Like the system window, the mini-alarm window appears automatically upon system start up and is visible at all times, unless it is intentionally covered by the operator or is temporarily covered by a pop-up window.

The mini-alarm window appears on all screens and cannot be maximized, minimized, closed or resized. Two alarm lines, one event line, and one operator message line are displayed.

The mini-alarm window (Figure 2-17) is composed of the following parts:

- Title bar.
- Process alarm display area.
- System event display area.
- Operator message display area.
- Alarm acknowledge buttons to acknowledge alarms, events and messages.
- Vector button on each process alarm line (lines 1 and 2), used to call up a predetermined display associated with the point which is in alarm.
- Filter button and more alarms (+ALARMS) indicator.

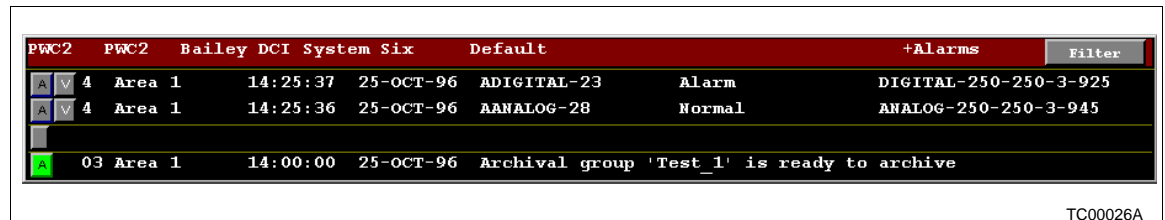

Figure 2-17. Mini-Alarm Window

The title bar identifies the window by PWC90 console name. The name of the current host node is displayed to the right of the PWC address; if the system (i.e., PWC1) communicating with the PWC is the primary node assigned to the PWC (refer to **Personal Work Center 90 Configuration** instruction), this will be displayed in normal video; if the host node is a backup node, the host node name will be displayed in reverse video. The title bar also contains a string which can be configured to provide further information, such as plant name and location. The login name of the user currently logged in on the PWC90 console appears on the title bar, followed by the +ALARMS indi-

cator (if more alarms exist), a *Silence* button, and the *Filter* button. (The *Silence* button contains a horn icon on the button face, and is visible only when audible alarms exist.)

The process alarm display area has a black background, on which up to two process alarms appear. The data contained in each line of the process alarm display area is displayed in a number of fields; the width of each field is configurable. The fields are:

- Priority.
- Area.
- Time.
- Date.
- Tag.
- Status.
- Alarm Tag.
- Legend.

The system event display area appears below the process alarm display area. Event messages report the occurrence of system events (as opposed to process events) such as database loading and server status (i.e., server is off-line). One event message is displayed in this area.

The operator message display area appears below the system event display. Operator messages are sent to all operators in an area of the plant to provide information. This feature provides the users with on line communication between areas which are distant from one another. Refer to **SYSTEM FEATURES** in Section 3 for details on use of the operator message feature.

An alarm acknowledge button is located at the leftmost side of each alarm line. this button is displayed in the priority color of the alarm, and contains the letter A until the associated alarm is acknowledged. If the associated alarm has been acknowledged, the button is displayed in the priority color of the alarm, but is otherwise blank. Individual alarms can be acknowledged by placing the cursor on this button and clicking the left mouse button.

A vector button is located immediately to the right of the alarm acknowledge button. This button contains the letter V. If alarm vectoring (refer to **Display Vectoring from the Alarm Review Display** in Section 8) has been configured for the point named in that alarm line, the display assigned via alarm vectoring will appear in the operator window which has the lowest number (i.e., operator *Window #1*). If no display has been assigned via alarm vectoring, the point display for the point in alarm will be used. If no operator window is open when the vector button is clicked on, no display appears. To cause the display to appear in an operator window other than the one with the lowest number, position the pointer on the vector button and press down

the left mouse button; continue to hold the left mouse button down while dragging the pointer inside the frame of the window you wish to contain the resulting display. The pointer will change shape to resemble a plus sign (+) during this operation. When the pointer is in the desired window, release the mouse button. If the user attempts to place the display in a window other than an operator window (i.e., a pop-up window), the PWC90 console will emit a beep to indicate an error, and no further action will be taken. Similarly, if the pointer is on an operator window frame (instead of inside the window or on the title bar) when the mouse button is released, the PWC90 console will beep and the operation will terminate. If the contents of the alarm line change during the drag operation, the alarm vectoring configuration in effect when the vector button was selected will remain in effect until the operation is completed.

The **+ALARMS** indicator is located immediately to the right of the title bar. This indicator appears when more process alarms exist than can be shown in the alarm display area (i.e., when there are more than two process alarms).

The filter button is located to the right of the title bar, beyond the **+ALARMS** indicator. Clicking on this button causes the *Mini-Alarm Filtering* window to appear; this window contains options which can be used to filter process alarms by priority, area and PWC90 console. If all alarms will be displayed the label on this button reads *Filter*; if some alarms will not be displayed due to filtering configured for the user's login, the label reads *Filtered*. The *Mini-Alarm Filtering* window also provides a toggle button with which to enable or disable audible alarms. This toggle button is functional when audible alarms have been enabled for the local PWC90 console via the *Device Type Assignment* window described The **Personal Work Center 90 Configuration** instruction.

**NOTE:** The message filtering configured for a user's login takes precedence over filtering configured at any other level. If access to a particular message type is filtered out at the login level, it cannot be turned on using the *Filter* button on the mini-alarm or using the *Filter* options which appear on the menu bars of the alarm review, event review, message review or event historian displays. All messages which are accessible to the user can be further filtered using these items. If the user elects to filter the contents of a display using a *Filter* option from a window menu bar or the mini-alarm window *Filter* button, the menu bar item will change to *L-FILTERED*, to indicate that filtering is local (L) to the window.

---

### **Operator Window**

The operator window provides the operator interface to the process, and can display output contained in process displays. These process displays include:

- Hierarchical displays (including summary, group and point displays).
- Trend displays.
- Graphics.
- System status display (SSD).
- Process alarm review.
- System event review.
- Printer review.
- Event historian.
- Message review (including server messages and operator generated messages).

By default, one operator window automatically appears at system startup (when the default account logs in) or when a new user logs in, if no default CRT contexts (described in **CRT CONTEXT KEYS** in Section 11) have been defined for these accounts. Under these conditions, additional operator windows will not automatically appear, but can be opened by the user. It is possible to have up to four operator windows open simultaneously on a PWC90 console. **Operator Window Operations** in this section provides further information on the default arrangement of operator windows. A user's login account can be configured to automatically open up to four operator windows each time that user logs in. The operator window can be maximized, closed and resized.

Because each operator window operates independently, a different process display can be run in each operator window. For example, while *Window #1* displays a summary page, *Window #2* could display a graphic, *Window #3* a trend display, and *Window #4* a process alarm display.

The operator window is composed of the three main window components: a title bar, a menu bar, and a display area.

The title bar identifies the number of the operator window and type of process display, if any, running in the window. In Figure 2-18, the title bar identifies the window as operator *Window #1* and reports that *SUMMARY 3* is displayed in the work area of the window (not shown). At the left end of the title bar is a small square button which contains a horizontal bar known as the window menu button, which provides access to the window control functions move, resize, and lower.

The menu bar provides the user with the following items:

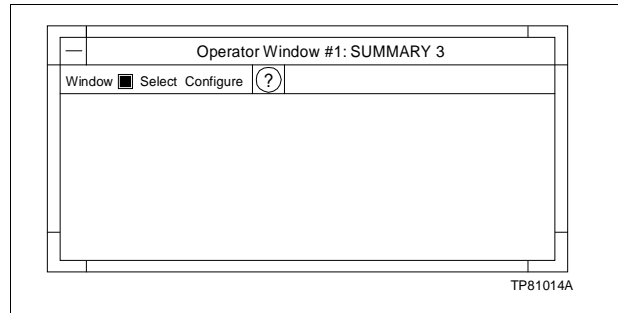

Figure 2-18. Operator Window

- Window.
- Maximize/restore button.
- Select.
- Help.

The *Window* button on the menu bar provides access to a cascading submenu of additional window control functions, including page up, page down, display back, display forward, acknowledge, and close.

The *Maximize/Restore* button on the menu bar is used to change the size of the operator window. Click on this button to enlarge a small operator window to fill the entire display area below the system and mini-alarm windows. Click on this button again to return the window to its previous size.

The *Select* button on the menu bar provides access to a cascading submenu of process interface features, such as graphics, trends, summaries, points, groups, quick keys, various review displays and the network status display. If the security level of the current operator does not allow access to an option, that option appears on the display, but in a lighter shade of gray; this effect is referred to as stippling.

The help icon on the menu bar allows the user to access on line, context sensitive *System Help*, as well as user generated *User Help*.

---

### **Operator Window Operations**

A maximum of four operator windows can be opened on the PWC90 console. As windows are opened on the screen, the size and location of each window and its contents are automatically adjusted to fit in the available space.

The PWC90 console is designed to open one operator window automatically when the system is started, when the default login state exists, or when a new user logs in (if no CRT Context has been assigned for that user). The first operator window

to be opened occupies the entire work area below the system and mini-alarm windows (Figure 2-19).

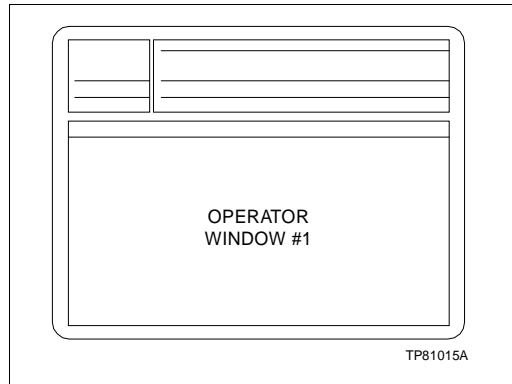

Figure 2-19. PWC90 Console with One Operator Window

If a second operator window is opened, operator Window #1 is resized to occupy the left half of the screen; operator Windows #1 and #2 are displayed side by side. The window contents are scaled to fit the new size (Figure 2-20).

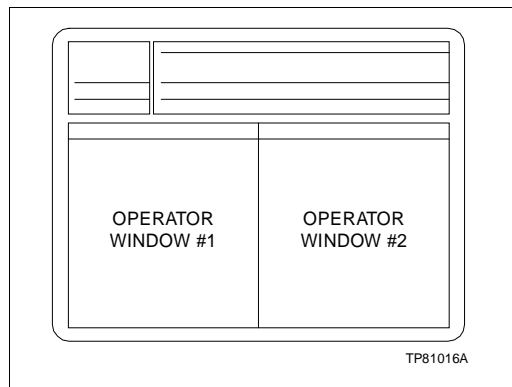

Figure 2-20. PWC90 Console with Two Operator Windows

Operator Window #3 will occupy the lower left quadrant of the screen work area, with operator Window #1 being resized and scaled to fit in the quadrant above it (Figure 2-21).

Operator Window #4 will occupy the lower right quadrant of the screen work area, with operator Window #2 being resized and scaled to fit in the quadrant above it (Figure 2-22).

Although the initial size and location of each window are predetermined, this can be modified, using the options available from the *Window* option on the operator window menu bar, or by using the resize handles.

The windows can be restored to their original size and shape at any time by selecting the *Arrange Windows* menu item, which

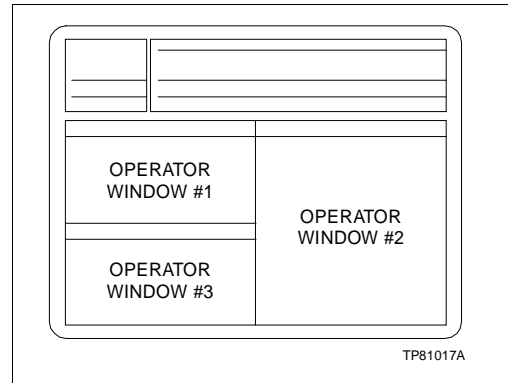

Figure 2-21. PWC90 Console with Three Operator Windows

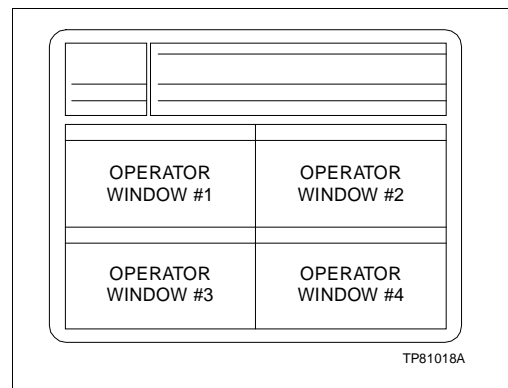

Figure 2-22. PWC90 Console with Four Operator Windows

is accessed via the *Menu* button on the system window, and discussed in **Arrange Windows Function** in this section.

---

**OPEN**

To open an operator window manually, the system window must first have keyboard focus. From the system window, select the *Menu* pushbutton. A pulldown menu will appear; from this menu select the *Windows* option. A second submenu will appear (Figure 2-23). From the submenu, select the first option, *Open New Window*.

Selecting the option to create an operator window causes that window to be opened in the display area of the screen below the mini-alarm window.

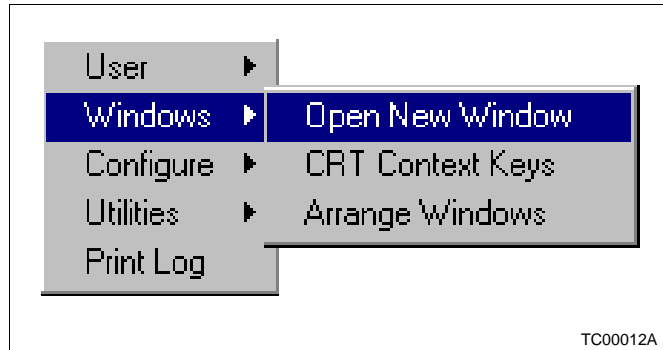

Figure 2-23. System Window Menu, Windows Option Selected

---

### PAGE UP/PAGE DOWN

The *Window* option on the menu bar provides *Page Up* and *Page Down* functions. These functions are used to move through other pages of the display currently on view in the display area, such as pages of an alarm review display. *Page Down* moves the user from a display with a lower page number to a display with a higher page number; i.e., from alarm review page one to alarm review page two. *Page Up* reverses the process.

*Page Up* and *Page Down* can also be used to move through displays of the same type, such as the 128 Summary displays.

The same functionality is provided by **Pg Up** and **Pg Dn**, located on the keyboard.

---

### FORWARD/BACK

The *Window* option on the menu bar provides *Display Back* and *Display Forward* functions. These functions are used to move backward and forward between the last ten displays which have appeared in the window, regardless of the display type. For example, a user might view a group display, then a point display, followed by a trend display. To return to the point display, the user need only select the *Display Back* function. This saves time and keystrokes by removing the need to call up the display via the *Select* button and resulting pop-up windows.

---

### CLOSE

To close an operator window, position the pointer on the *Window* on the menu bar of the window. Select *Close* from the resulting cascade menu. A modal pop-up window will appear (all other input is rejected until the user responds to and closes the modal pop-up window). The pop-up window asks:

*Close Window?*

The pointer must be positioned on a *Yes* or *No* button, and the left mouse button clicked. No other action can be taken until a selection is made. This guards against accidental closure of an operator window. Any remaining windows will be resized as described in **Operator Window Operations** in this section.

---

### **RESIZE**

An operator window can be stretched or shrunk by using the *Resize* menu item (available from the window menu button at the left of the title bar), or by using the resize handles located on the frame of the operator window. Window size can be changed vertically, horizontally or diagonally (in two directions). The display which appears in the window is automatically adjusted to the new window size.

To resize an operator window using the *Resize* menu item, position the pointer on the window menu button and press the left mouse button. On the resulting pull-down menu, select the *Resize* option. Selection can be made using the mouse or by pressing the letter **R** on the operator's keyboard.

The operator window can also be resized using the resize handle segments of the window's frame, as described in **RESIZE** in this section.

---

### **Arrange Windows Function**

If the size and/or location of a window has been modified, the windows can be restored to their original size and shape at any time by selecting the *Arrange Windows* menu item.

To access the *Arrange Windows* function using the menu system, first select the system window *Menu* button. From the resulting pull-down menu, select the *Windows* option. The *Arrange Windows* function can be selected from the resulting cascading menu.

Selecting this menu item will arrange the open operator windows so that none overlap and the screen area is divided as evenly as possible among these windows, as shown in Figures 2-19 through 2-23. The pointer will be moved to the upper left corner of the screen. Any pop-up windows present will be unchanged in size and position.

---

### **Summary - Window Types, Components and Operations**

#### **Alarm Acknowledge Button**

The alarm acknowledge button is located at the leftmost side of each alarm line. This button is displayed in the priority color of the alarm, and contains the letter *A* until the associated alarm is acknowledged. If the associated alarm has been acknowledged, the button is displayed in the priority color of the alarm, but is otherwise blank. The user may acknowledge individual

alarms by placing the cursor on this button and clicking the left mouse button.

<b>Arrange Windows</b>	A function which allows all operator windows present to be quickly restored to their original size, shape and location.
<b>Cascading Menu</b>	A cascading menu is a submenu, which provides selections that amplify the parent selection on a pull-down or pop-up menu.
<b>Check Button</b>	A check button is a type of graphic control button used to select settings that are not mutually exclusive. The visual cue used to indicate that an item has been selected consists of a selected button that is filled in or checked.
<b>Dialog Box</b>	A dialog box is a window displayed as a result of a user action containing graphical controls such as toggle buttons, radio buttons or other pushbuttons.
<b>Entry Box</b>	An entry box is an area, usually located in a pop-up window, which allows the entering of text. The text can be a simple string, such as a key label, or multiple lines, such as user help text (refer to <b>RELEASE ALL CONFIGURATION LOCKS</b> in Section 11).
<b>Bailey Logo Pushbutton</b>	A pushbutton on the system window. Press this button to display the PWC90 software version number.
<b>Filter Button</b>	The filter button is a pushbutton located at the right end of the mini-alarm window title bar, beyond the more alarms indicator. Pressing this button causes a pull-down display to appear; this display contains options which can be used to filter process alarms by priority, area and PWC90 console.
<b>Help Icon</b>	The help Icon is a button which contains a question mark (?). Press this button to display further information regarding the current operation.
<b>Keyboard Focus</b>	The PWC90 console uses the explicit model of keyboard focus; that is, the pointer (also known as the mouse cursor must be positioned somewhere on the window which is to receive input from the keyboard (or other input device). The left mouse button must then be pressed once to select the window. The color of the border and title bar of the selected window will then change, and that window will receive keyboard input.
<b>List Box</b>	A list box is an area within a window containing a scrollable list of options from which to choose. An example of a list box is the list of alarm priority colors.
<b>Menu Bar</b>	An area located below the title bar on an operator window. The menu bar contains several options, including select and help. Other options can be present; this depends on the type of display contained in the window.

<b>Menu Pushbutton</b>	The menu pushbutton is located on the system window and provides access to system, security and network parameters as well as configuration functions.
<b>Mini-Alarm Window</b>	The mini-alarm window is located to the right of the system window on the PWC90 console screen. It automatically appears upon system start up and is visible at all times. The mini-alarm window provides a title bar, an alarm display area, an event display area, alarm acknowledge buttons to acknowledge alarms and events, and a filter button and more alarms (+ALARMS) indicator.
<b>Operator Window</b>	Located on the PWC90 console screen below the system window and mini-alarm window, the operator window provides the operator interface to the process, and displays program output from operator window process displays such as hierarchical displays, trends, graphics, alarm review, etc. The operator window is composed of a title bar, a menu bar, and a display area. Up to four operator windows may be present simultaneously on a PWC90 console.
<b>Option Menu</b>	An option menu is a list of items which are selectable using associated check buttons or toggle buttons.
<b>Pop-Up Menu</b>	A menu that appears any where on the screen other than the standard menu bar location.
<b>Pull-Down Menu</b>	A pull-down menu is a menu which is pulled down from the window menu bar.
<b>Pushbutton</b>	A pushbutton is an area of the screen surrounded by a border shadow. When the pushbutton is selected (pressed), the shadow moves to give the illusion that the pushbutton has been pressed in 3 D look. When the pushbutton is unselected, the shadow moves to give the appearance that the pushbutton has been released. Pushbuttons can contain text, numbers, colors or symbols such as directional arrows. For example, the Bailey logo appears on a button in the system window. Selecting a pushbutton causes an action to take place; for example, selecting the <i>OK</i> button on a display allows the user to exit the display and commit any changes made via the display. Conversely, selecting the <i>Cancel</i> button causes the user to exit the display and abandon any changes or selections made via that display.
<b>Resize Handles</b>	Resize handles are segments of a window frame which can be used to shrink or stretch the window, changing the window size vertically, horizontally or diagonally (in two directions). The display which appears in the window is automatically adjusted to the new window size.
<b>Scroll Bar</b>	A scroll bar is a feature used to view data that is too large to be viewed in its entirety in the associated work area. (The work area typically contains data such as a list or block of text.) A

scroll bar consists of two arrows pointing in opposite directions at each end of a small rectangle. The rectangle is called the scroll region. A smaller rectangle called the slider is located within the scroll region. The ratio of slider size to the scroll region size corresponds to the relationship between the visible data and the total amount of data. For example, if fifty percent of the data is visible in the work area, the slider will fill fifty percent of the scroll region. Scroll bars can be located both horizontally and vertically. Horizontal scroll bars are located at the bottom edge of a work area; vertical scroll bars appear at the right edge.

To scroll through the data in the work area, position the pointer on the slider, press the left mouse button, and drag the slider through the scroll region. Release the left mouse button when the desired data is in the work area.

<b>Scroll Region</b>	Refer to Scroll Bar.
<b>Slider</b>	Refer to Scroll Bar.
<b>System Window</b>	A small window located at the top left corner of the PWC90 console screen. It appears automatically upon system start up, and is visible at all times unless deliberately covered by the operator. The system window provides a date/time indicator and a menu button for access to other system features and utilities.
<b>Tab Group</b>	Items on a window between which focus can be shifted using either <b>Ctrl-Alt</b> combination or the arrow keys.
<b>Title Bar</b>	An area located at the top of a PWC90 console window, which provides information to identify the window.
<b>Toggle Button</b>	A toggle button is a small square or diamond shaped box located to the left of text or graphics items. These items can be selected or deselected using the toggle button. Select the item by positioning the pointer inside the toggle button and click the left mouse button. The toggle button then changes to the selection color, indicating that it has been selected. Click on the toggle button again to unselect it.
<b>Vector Button</b>	A vector button is located immediately to the right of the alarm acknowledge button in each alarm line. This button contains the letter V. Clicking on this button allows the user to vector to a display previously assigned to the point which appears in that alarm line. If no other display has been previously configured, the point display for the point in alarm on that alarm line will appear. The display called up in this manner will automatically appear in the operator window with the lowest number. To load the display in a different operator window, position the pointer on the vector button and continue to hold the left mouse button while dragging the pointer to the desired opera-

tor window. Release the left mouse button when the pointer is inside the frame of the target window.

**Window** A rectangular section of the screen, which has a background color and a border. Windows may also incorporate scroll bars, title bars, and other higher level user interface components. See also system window, mini-alarm window, and operator window.

---

## SECTION 3 - PWC90 CONSOLE FEATURES

---

### INTRODUCTION

The Personal Work Center 90 (PWC90) contains features which aid in use and management of the system. These features include activities such as:

- Logging in.
- Logging out.
- Changing passwords.
- Opening and arranging windows.
- Accessing utilities.
- Accessing the system status display.
- Printing logs and CRT screen contents.

This chapter provides basic information required to get started using the system, then moves on to briefly discuss various system features. Note that this manual does not attempt to describe configuration operations; refer to the **Personal Work Center 90 Configuration** instruction for details on configuration.

Many of these system features are accessed using the menus available via the system window *Menu* button. (The system window is described in **System Window** in Section 2.) To access these menus, click on the system window *Menu* button, then continue to make selections (by clicking on items) from the resulting pull-down and cascading menus, until the desired item is selected.

---

### GETTING STARTED

One of two states can exist on a PWC90 console that is running:

- System default state (no user logged in).
- User logged in state.

---

#### **System Default State**

The system default state occurs after a PWC90 console initial start up or restart, after a user has logged out of a PWC90 console or when a PWC90 console is restarted.

- Security access level, quick keys and CRT context keys are those defined in the default login setup.
- Username in the title bar of the mini-alarm window is *Default*.

- Displays contained in the operator windows are those defined in the initial login displays of the default login setup. If no initial login displays are defined for the default login, a single operator window is opened, which contains the system status display.

When the system default state exists, the system responds as though a user named *Default* is logged in on the system. Depending on the security level assigned to this *Default* user, various activities can be performed on the system, such as opening operator windows, viewing displays or printing the contents of the CRT.

If logged in as ***pwcuser*** the PWC90 system is started automatically but does not permit a full shutdown of PWC. This is because ***pwcuser*** is the target operator account (auto log in) and full shutdown privileges are withheld. If necessary a user with administrative privileges can use *PWC Maintenance* to select *Full PWC Shutdown* under the *Basic* menu item to perform a full shutdown.

---

### Logging In

The user logged in state exists when a user (other than *Default*) has logged in. To login, click on the system window *Menu* button, then select the *User* option from the system window pull-down menu. A second menu cascades from the first, as shown in Figure 3-1.

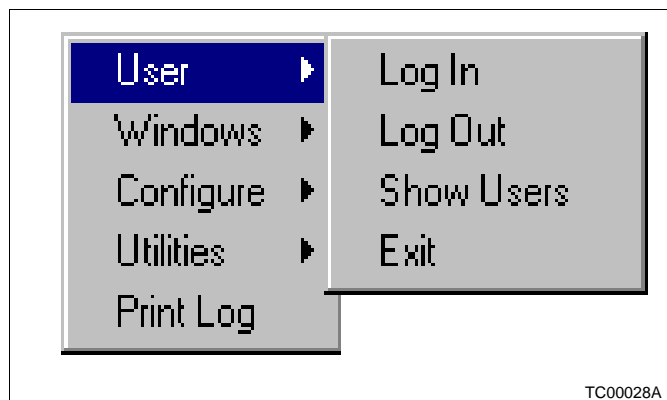

Figure 3-1. System Window Menu with Login/Logout Menu

This menu allows the user to login to (or logout of) the PWC90 console. A security system of access levels controls the user's access to areas and priorities as well as network and server functions. When the security system is active, the user's access to these parameters is defined by the system default or by the user's login configuration. When the security system is inactive, no restrictions are placed on the user's access abilities.

To login, click on *Log in*; the PWC90 console login window appears, as shown in Figure 3-2.

In the area next to the *Log in* prompt enter the login name of the user to be logged in, using either the PWC90 console keyboard or by clicking on the appropriate keys on the video keyboard which appears in the login window. The login name should be followed by **Return** (or by clicking on *OK*). Next, enter the password in the same manner, again followed by **Return** (or by clicking on *OK*).

The operation can be aborted at any time prior to completion. To do so, click on *Cancel* which appears on the PWC90 console login window.

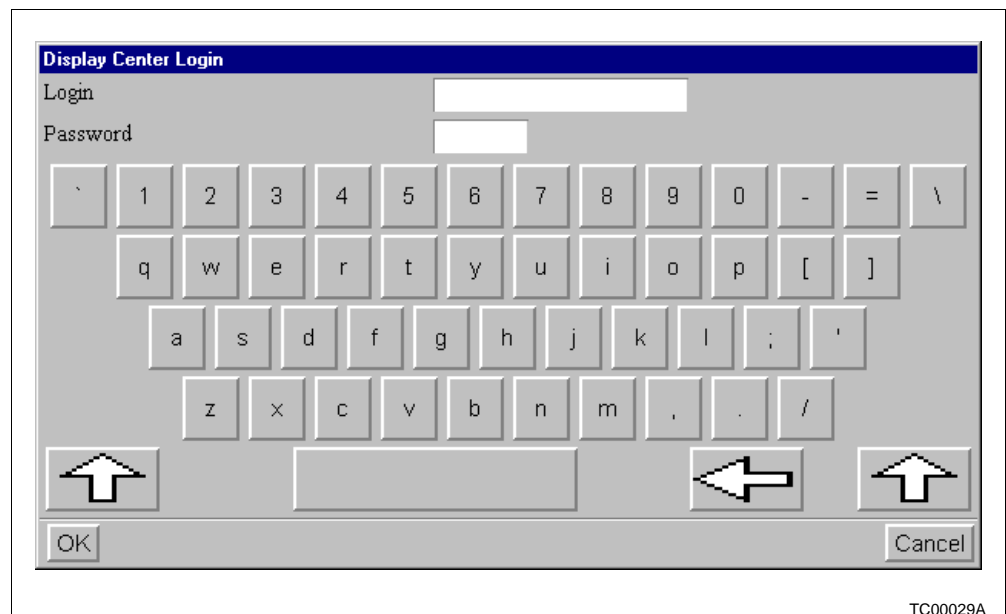

Figure 3-2. PWC90 Console Login Window

If an incorrect login name or password is entered during a login attempt, a system event message will be generated; this message will appear in the system event display area of the mini-alarm window. The message will also be stored in the event historian (refer to **EVENT HISTORIAN** in Section 9). The message will include the time and date, the node name, the name of the user already logged in on the PWC90 console at the time of the unsuccessful attempt, a message regarding the invalid attempt, the name of the PWC90 console on which the unsuccessful login was attempted, and the name under which the invalid login was attempted; for example:

```
16:42:43 12-JUL-95 PWC1 User Default Invalid Login
Attempt on Terminal PWC1_PWC1:0 fred.
```

Here, the default user was logged in on PWC1 when the user fred unsuccessfully attempted to login.

If the attempt is unsuccessful, a pop up window will be displayed, which prompts:

*!Login failure.  
Try again?*

Click on *OK* to close the pop up window and return to the PWC90 console login window.

**NOTE:** It is possible to configure a user login account which is restricted from using specified systems. If you cannot login on a PWC90 console, your account may be restricted from using it. Ask your system administrator for details on PWC90 console availability from your login account.

The initial displays assigned in the user's login configuration are placed on the PWC90 console used for the login operation. The quick keys (refer to **QUICK KEYS** in Section 11) and CRT context keys (refer to **CRT CONTEXT KEYS** in Section 11) assigned in the user's login configuration are available to the user. The user's name is displayed in the title bar of the mini-alarm window.

A user can login on a terminal which already has an active login on it. This action causes the previous user to be logged out. If the new user has defined an initial CRT context (i.e., CRT login context key), the screen will display this new environment. If no initial screen context has been defined, the displays on the screen remain unchanged.

**NOTE:** If Security is activated on the system, and a user's login account is configured to filter out (exclude) messages from one or more process areas, then that login account cannot be used to perform tag operations on the process areas for which message filtering has been applied. Questions on how message filtering is configured on your system and specifically for your account should be directed to your system administrator. Configuration of these items is discussed in the **Personal Work Center 90 Configuration** instruction.

---

## Logging Out

When a user logs out of the PWC90 console, the following actions take place only on the computer from which the user is logging out:

- The security access level, quick keys and CRT context keys change to those defined for the default user.
- The username in the title bar of the mini-alarm window changes to *Default*.

- The login context changes to that of the default user, and the login parameters will change to those of the default user. (In other words, when an actual user logs out, the PWC90 console returns to the default login state; it is as if the default user had logged in.)

The logout procedure is very similar to that used to login. To logout, click on the system window *Menu* button, then select the *User* option from the system window pull-down menu. A second menu cascades from the first. Click on *Log Out* menu item; the current user will be logged out.

---

### ***Changing Your Password***

When a login is initially configured, the password for the login defaults to the first seven characters of the username entered for the login. One of a new user's first actions should be to change this password, to prevent unauthorized persons from using the account.

A good password is an essential component of system security. The user should use the following guidelines when choosing a password:

- Avoid the obvious choices, such as names, social security numbers, words that appear in a dictionary, license plate numbers, etc.
- Make it complex; use a mixture of upper and lower case letters, as well as numbers, in the password.
- Use all seven characters; a password that is too short is easy to guess.

While the user is not prevented from using a single character or spouse's name as a password, this is not good practice.

To change a password, the user must:

1. Login on the system.
2. Click on the system window *Menu* button.
3. Click on *Configure* in the resulting pull-down menu.
4. Click on *Security* in the *Configure* menu.
5. Click on *Change Password* in the *Security* menu. The *Change Password* window (Figure 3-3) appears.

A text entry box appears to the right of the word *Log in*. Enter your login name in this area, followed by **Return**. Use the same method to enter your current password for that login name.

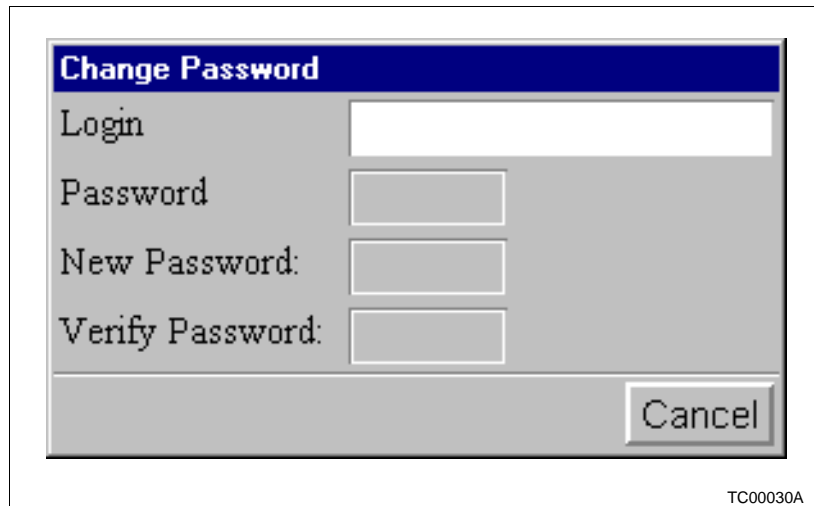

The image shows a graphical user interface window titled "Change Password". The window has a blue header bar with the title. Below the header, there are four text input fields arranged vertically. The first field is labeled "Login". The second field is labeled "Password". The third field is labeled "New Password:". The fourth field is labeled "Verify Password:". At the bottom right of the window, there is a "Cancel" button. The window is set against a light gray background.

TC00030A

Figure 3-3. Change Password Window

Note that the password will not be displayed on the screen, for security reasons.

For most users, this operation will be performed only on one's own login name and password, although it is possible for a user with a higher access level (refer to **Security** in this section) to change the password of a user with a lower access level. Note that by being required to enter the password as described above, the user is forced to prove possession of the original password before it can be changed.

Next, enter the *New Password* in the appropriate text entry box, followed by **Return**. Enter the new password again, this time in the *Verify Password* text entry box. Because the passwords do not appear on the screen, this step is essential to make sure that there were no typing mistakes when the new password was entered.

After the new password is typed in the *Verify Password* text entry box, enter **Return** to complete the operation. If the new password and the verification entry match, the new password is accepted and the *Change Password* window is removed from the screen. If they do not match, a pop up window (Figure 3-4) appears, advising the user to try again.



Figure 3-4. Illegal Entry Pop Up Window

## SYSTEM FEATURES

Clicking on the system window *Menu* button produces a pull-down menu containing the following items:

- User.
- Windows.
- Configure.
- Utilities.
- Print Log.

The first item, *User*, has been discussed in **GETTING STARTED** in this section. The other menu items provide access to additional features which allow the user to:

- Open windows (described in **Operator Window** in Section 2).
- Arrange windows (described in **Arrange Windows Function** in Section 2).

With proper security access levels:

- Perform configuration operations. Discussion of configuration topics is beyond the scope of this document; the user is referred to the **Personal Work Center 90 Configuration** instruction for details on configuration.
- Change passwords (described in **Changing Your Password** in this section).

Access PWC90 console utilities (described in **PWC90 UTILITIES** in Section 11), which include:

- Backup and restoration of data.
- Manual data entry.
- Historical database maintenance operations.
- Archival database maintenance operations.
- Print the all or part of the contents of a screen.

- Use the calculator pop up display.
- Message configuration.
- Message routing.
- Print logs on demand.

Additional PWC90 console features which aid in management of the system and with which the user should be familiar are:

- Security (refer to **Security** in this section), which determines limits of a user's ability to access items on the PWC90 console.
- System status display (refer to **SYSTEM STATUS DISPLAY** in this section), which provides information on the PWC90 consoles and INFI 90 OPEN server nodes.

---

## Security

The PWC90 console includes a security system of nine access levels which control the user's access to:

- PWC90 console functions.
- Process control functions.
- Plant areas.

Access levels are assigned to both users and to the areas and functions. You must have an access level equal to or higher than that of the function you wish to use, in order to have access to it. The nine access levels are displayed in Table 3-1.

Table 3-1. Access Levels

Name	Ranking
Operator Level 1	(Lowest Access Level)
Operator Level 2	
Operator Level 3	
Engineer Level 1	
Engineer Level 2	
Engineer Level 3	
Supervisor Level 1	
Supervisor Level 2	
Supervisor Level 3	(Highest Access Level)

Security can be configured to be active or inactive on the PWC90 console. When the security system is active, the user's access to these parameters is defined by the system default or by the user's login configuration. When the security system is inactive, no restrictions are placed on the user's access abilities.

If you do not have access to a function, the menu item or button for that function will appear stippled out. If you encounter difficulty in accessing a function or plant area, see your system administrator to verify that you have been assigned the proper access level or to have your access level changed.

---

### **Message Configuration**

A method of communication between operators is available on the PWC90 console, allowing text messages known as operator messages to be sent from one plant area to another. The message configuration feature provides this method of generating operator messages from a PWC90 console.

To create an operator message, access message configuration by using the pull-down menus available from the system window *Menu* button. Click on *Menu*; from the resulting pull-down menu, click on *Configure* option, then click on *Message Configuration* in the resulting cascading menu. The *Message Configuration* window (Figure 3-5) will be displayed.

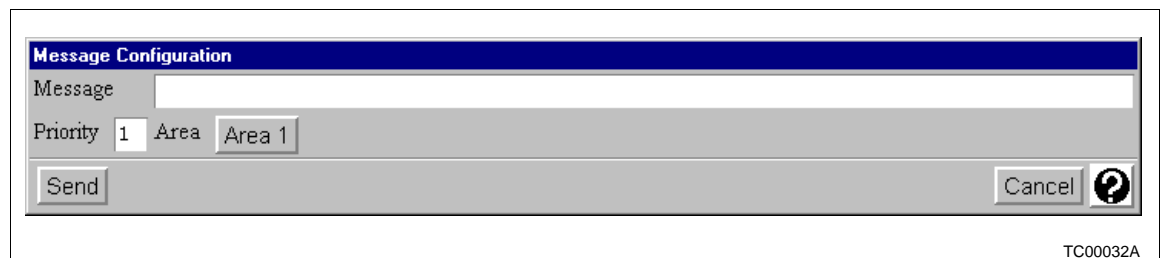

Figure 3-5. Message Configuration Window

The window is used to configure the text, priority and destination of the operator message.

---

#### **MESSAGE TEXT**

To configure the text of the message, click on the text entry box located at the top of the *Message Configuration* window to gain focus on it, then enter a message of up to 80 ASCII characters.

---

#### **MESSAGE PRIORITY**

Each message is associated with a priority. To set the priority, click on *Priority* text entry box and enter the number of the desired priority (range of 1 - 16).

---

#### **MESSAGE DESTINATION AREA**

Each message can be associated with a specific plant area. The *Area* assignment is used to route the message to the devices (files, printers) which have been configured to receive operator

messages associated with that area. The message will also be sent to all PWC90 consoles where users who have access to that area are logged in. On the PWC90 console, the message will be displayed in the message line (bottom line) of the mini-alarm window. To assign the operator message to an area, click on *Area*. The *Area Selection* window (Figure 3-6) will be displayed.

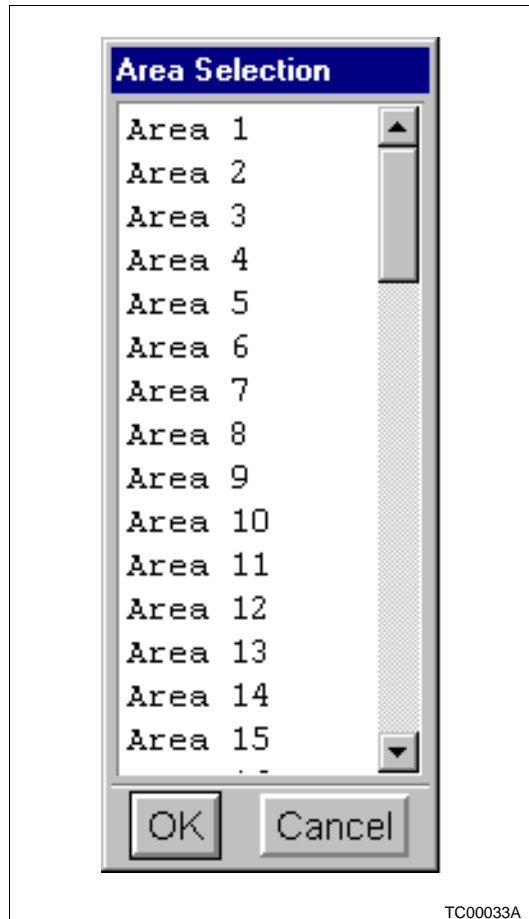

Figure 3-6. Area Selection Window

The area selection window consists primarily of a scrollable list box which contains 64 areas. To select the destination area for the operator message, click on the desired area, then click on *OK*. The default is *Area 1*. (To exit without changing the area assignment, click on *Cancel*.)

---

### **SEND THE OPERATOR MESSAGE**

To send the operator message and exit *Message Configuration*, click on *Send*. To exit without sending the message, click on *Cancel*.

---

### **Message Routing**

Information on various topics is provided by the system in the form of messages. Messages are divided into categories called message classes; this enables the system to distinguish between different kinds of messages and allows efficient message sorting.

Messages within each class are further distinguished by separation into message types. Definitions of types within a message class enables the PWC90 console to quickly process and/or sort messages within a class. Message classes in the PWC90 console include:

- Process alarms.
- System events.
- Operator messages.
- Operating status messages.
- Operating errors.
- Operator actions.

Process alarms, system events and operator messages provide information which must be immediately available to the operator; messages from these three classes are displayed in the mini-alarm window on the PWC90 console screen. The remaining message classes reflect status changes in the system rather than alarm conditions; messages belonging to these classes are not displayed in the mini-alarm window. Logging of messages is configurable; questions on how message routing is configured on your system should be directed to your system administrator.

In addition to message classes, message routing also allows the filtering of messages based on the following parameters:

- Priority.
- Area.
- PWC.

Message routing enables messages of any message class to be separately routed to any device which has been configured through the *Printer Assignment* menu selection. message routing also defines which message types in each message class are to be routed to any device, filtering out messages which are not important for the specific application.

---

### **MESSAGE COLOR DEFINITION**

By default, messages which are sent to a printer are printed in black, and messages which are sent to a file appear as black characters on a white background.

Different colors can be configured for use when a message from a particular class is sent to a file (or to an optional color printer).

**NOTE:** The message color defined here is used when the message is logged to a device (file or printer); it is *not* the same as alarm priority color (refer to **Process Alarm Priorities** in Section 8), and will not affect messages in the mini-alarm window or alarm review display.

If you have questions regarding message color definition on your system, contact your system administrator.

---

### **MESSAGE INDENTATION DEFINITION**

Another feature which can be configured on the system is the number of spaces of indentation to be used for each message class. Where a number of different message classes are routed to the same printer, a different indentation can be used for each message class; this can assist the user when looking for messages of a particular class.

If you have questions regarding message indentation definition on your system, contact your system administrator.

---

### **MESSAGE CLASS: PROCESS ALARM MESSAGES**

Process alarm messages are displayed in the top two lines of the mini-alarm window, known as the alarm display area.

Process alarms are displayed in the following format:

<Priority><Area><Time><Date><Tagname><AlarmCondition><Legend>

Process alarm messages are classified into the following message types:

- Bad Input/Output.
- High/Low alarm.
- Deviation alarm.
- Security alarm.
- Process alarm message.
- Discrete alarm.
- Return to normal.
- Alarm acknowledged.

Process alarm messages can be filtered by message type.

---

**MESSAGE CLASS: SYSTEM EVENT MESSAGES**

System event messages are displayed in the third line of the mini-alarm window, known as the event display area. System event messages are displayed in the format of the following example:

<Time><Date> INFI 90 OPEN CIU IS OFFLINE

System event messages are classified into the following message types:

- Server events.
- PWC events.
- Network events.
- Return to normal.
- Event acknowledged.

System events can be filtered by message type.

---

**MESSAGE CLASS: OPERATOR MESSAGES**

Operator messages are messages sent by an operator to all operators in an area, and appear in the fourth line of the mini-alarm window.

Operator messages are displayed in the format of the following example:

<Priority><Area><Time><Date> Acid Tank Levels High.

Operator messages are classified into the following message types:

- Operator message.
- Operator call.
- Message acknowledged.
- Operator call acknowledged.

Operator calls are messages issued from a server. Operator messages can be filtered by message type.

---

**MESSAGE CLASS: OPERATING STATUS MESSAGES**

Operating status messages are sent to a device designated via the message routing assignment matrix. This device can be a printer or a file. Operating status messages are displayed in the format of the following example:

<Priority><Area><Time><Date><Tagname><Status Legend><Legend>

Operating status messages are classified into the following message types:

- Operating messages.

Operating status messages can be filtered by message type.

---

**MESSAGE CLASS: OPERATING ERRORS**

Operating error messages are sent to a device designated via the message routing assignment matrix. This device can be a printer or a file.

Operating error messages are displayed in the format of the following example:

```
<Time><Date><Device> Insufficient Permission to Add/Remove Red Tag.
```

Operating error messages are classified into the following message type:

- Operating message.

Operating error messages can be filtered.

---

**MESSAGE CLASS: OPERATOR ACTIONS**

Operator action messages are sent to a device designated via the message routing assignment matrix. This device can be a printer or a file.

Network operator action messages are displayed in the format of the following example:

```
<Area> <Time> <Date> <Username> <TerminalName> HS-5441.C_DPV  
NEW=1 OLD=0
```

PWC90 console operator action messages are displayed in the format of the following example:

```
<Time><Date><Username><TerminalName>graphic 1 installed
```

Operator action messages can be filtered.

---

**MESSAGE FILTER PARAMETERS**

In addition to the above message classes, messages can also be filtered to include or exclude messages according to the following parameters:

- Priority.
- Area.
- PWC.

## SYSTEM STATUS DISPLAY

The system status display (SSD), shown in Figure 3-7, provides information about each node connected to the INFI 90 OPEN system. A node can be a Personal Work Center 90 (PWC90) console or a server. PWC90 consoles on the network are labelled as PWCs.

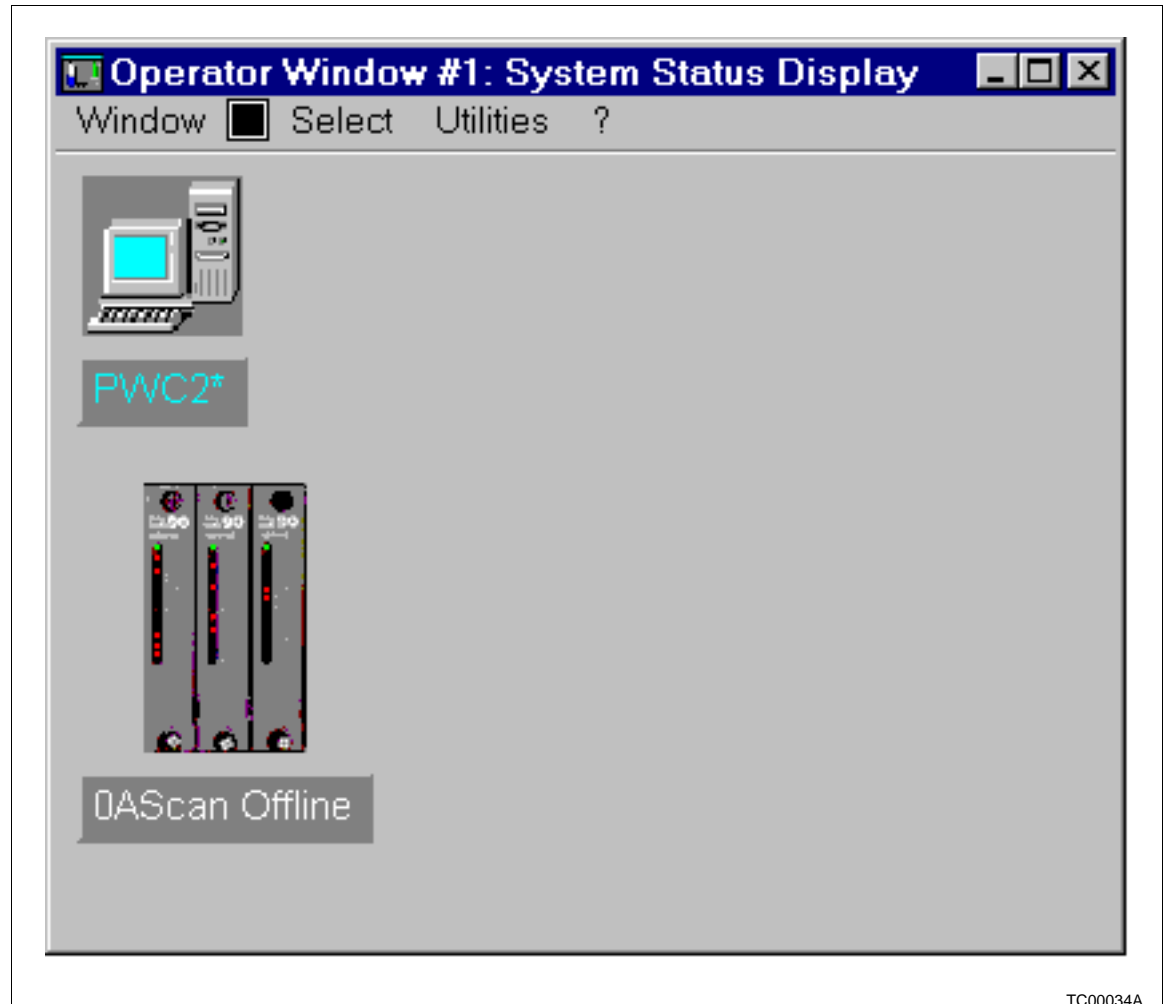

TC00034A

Figure 3-7. System Status Display

Each node on the network is depicted by a pictorial representation known as an *SSD object*.

An SSD object is composed of a schematic illustration of the node above a button containing the name of the node and information on the state of the node and its connections to the INFI 90 OPEN system. The appearance of the SSD object varies, depending on the type and state of the node. Click on the button to access a pull-down menu for the node represented by the SSD object. Like the appearance of the SSD object, the entries on the pull-down menu vary with the type of node rep-

resented. Figure 3-8 is an example of the SSD object for a PWC90 console.



*Figure 3-8. SSD Object for a PWC90 Console*

The system status display is organized into rows of nodes, using following rules:

1. A row contains nodes of only one type of device (i.e., servers).
2. The rows of device types are ordered as follows, from top to bottom:
  - Personal Work Center (labelled PWC).
  - INFI 90 OPEN server.
  - Other.

If no nodes of a particular device type exist, subsequent rows of other devices are moved up in the SSD (i.e., no blank rows are created).

3. A row can contain up to eight nodes. If more than 8 nodes of one type exist on the network, they are displayed on multiple, consecutive rows.
4. Within a row, nodes are ordered left to right according to device number; i.e., PWC1 appears to the left of PWC2, and so on.

**NOTE:** The INFI 90 OPEN network is separate from the PWC90 network. The INFI 90 OPEN network is only a node on the PWC90 network.

If more nodes exist on the network than can be shown in the normal viewing area of the SSD, scrollbars will appear at the right and bottom sides of the display. These can be used to view the portions of the SSD which extend beyond the normal viewing area.

If the operator window containing the SSD is positioned so that a SSD object is near the right edge of the screen, it may be dif-

difficult to use the pull-down menu for the node in the normal manner. There are two possible solutions to resolve this problem.

1. Resize or move the window so that the node is not at the right edge.
2. Use the bottom scrollbar to shift the contents of the window so that the node is not at the right edge.

---

### ***PWC90 Nodes***

All SSD objects, regardless of node type, share certain features, including:

- Node name.
- Info menu.

These features are discussed in the following paragraphs.

---

### ***NODE NAME***

The *Node Name* is displayed on the face of the button which is located below the schematic illustration of the node (the Node Icon). The node name is composed of a three character descriptor which indicates the device type (i.e., server, or PWC90 console) followed by the device number (i.e., PWC6). The color of the node name indicates the network status of the node, as follows:

**Cyan** Indicates that the node is the local PWC90 node. The terminal on which the SSD is displayed is controlled by this PWC. The node icon of the local PWC90 node is also displayed in cyan.

**NOTE:** The local node is also indicated by an asterisk (\*) following the node name.

**White** Indicates the node is on the network. The node can be accessed by the local PWC.

**Black (Text and Node Icon) on Red (Button Color)** Indicates that the node is not currently on the network. The node can no longer be accessed from the local PWC90 console. (However, the node was accessible at some point in time following the most recent restart of the local PWC. If the node is still inaccessible at the time of the next local PWC90 console restart, it will be removed entirely from the SSD). The pull-down menu of the node cannot be used in this state. The node icon is displayed in black, as well as the node name.

**NOTE:** In this case the node name is also enclosed in parentheses.

---

### **INFO MENU**

Click on the button containing the node name to display the pull-down menu for a node. The pull-down menu for each node contains a button labeled *Info*. Click on this button to access a cascading menu titled *Info Menu*. This *Info Menu* contains, at the minimum, the following two entries:

- *Network Info*.
- *Show Available Services*.

---

### **Network Info**

Clicking on the *Network Info* item in the *Info Menu* will cause a *Network Info* window (similar to the example in Figure 3-9) to be displayed.

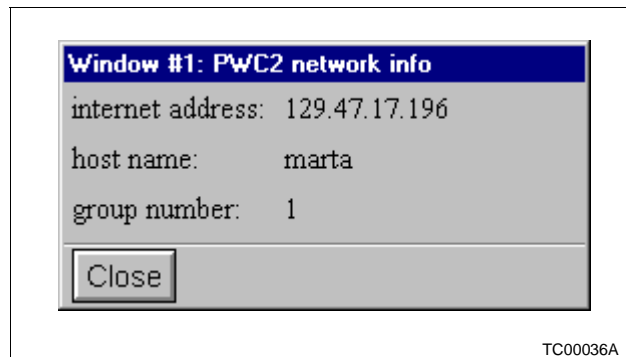

Figure 3-9. Network Info Window Example

This window contains read only information about the node selected from the system status display. The information will include the internet (IP) address, the host name (if any), and the ethernet address of the node (if known).

Click on *OK* to return to the system status display.

---

### **Show Available Services**

Clicking on *Show Available Services* item in the *Info Menu* will cause a *Services* window (similar to the example in Figure 3-10) to be displayed.

This window contains a read only list of the services available on the PWC90 console selected from the system status display. This information is used by technical support personnel during trouble shooting. If a node function does not work as expected, check this list to find out if the service is actually available on the node. Note that each data transaction on the network is preceded by a code number identifying the service associated

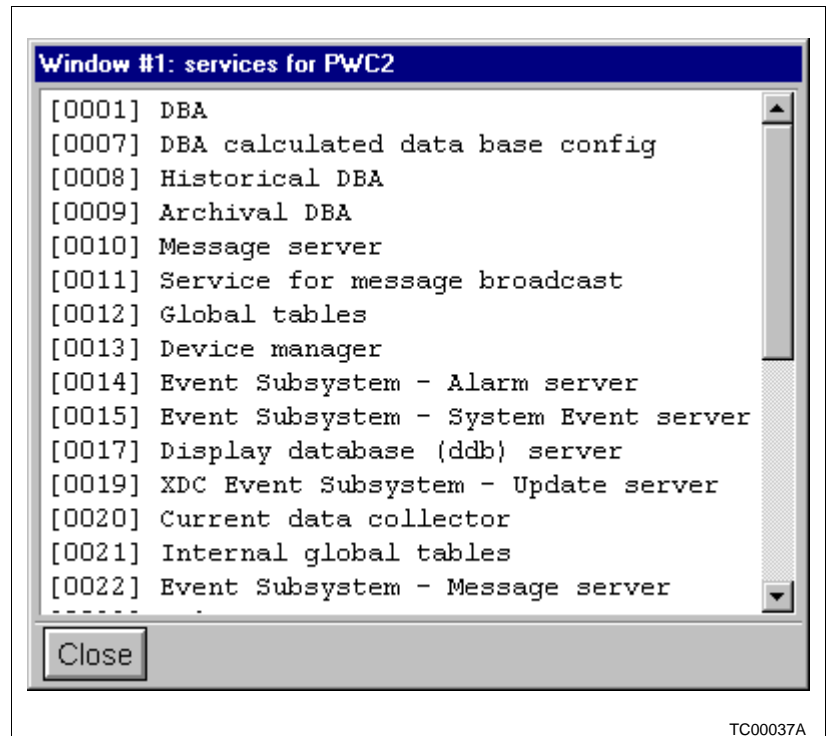

Figure 3-10. Services Window Example

with the transaction. These code numbers are shown in brackets preceding each item on the list of available services.

Click on *CLOSE* to return to the system status display.

### INFI 90 OPEN Server Nodes

The INFI 90 OPEN server node provides access to the INFI-NET network (Figure 3-11). Multiple servers may access the same INFI 90 OPEN network but must use unique tagnames. The server button gives access to a pull down menu of available services.

- Info.
- Server configuration.
- Server diagnostics.
- Server tag summary.
- INFI-90 block details.
- INFI-90 module status.

The Info option displays a pop-up window that provides information on the server such as:

- Type of server.
- Server host.
- Server name.

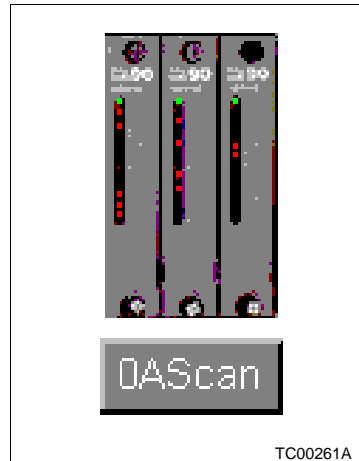

Figure 3-11. SSD Object for a Server

*Server Configuration* invokes the tag configuration application. For more information on this application refer to the **Personal Work Center 90 Configuration** instruction.

*INFI-90 Module Status* invokes the operating parameters application. For more information on this application refer to [Section 13](#).

*Server Tag Summary* invokes the tag summaries application. For more information on this application refer to [Section 14](#).

*Server Diagnostics* invokes the server diagnostics application. For more information on this application refer to [Section 15](#).

*INFI-90 Block Details* invokes the block details application. For more information on this application refer to [Section 17](#).

---

## Utilities Menu

The *Utilities* option, located on the *System Status Display* menu bar, provides access to printer device status information and printer control utilities, discussed below. To access these functions, click on the *Utilities* item on the menu bar. Then select *Device Status*, to access the printer control utilities. Click on this item to display the *Device Status* window (Figure 3-12).

**NOTE:** If no devices are configured, a confirmation box will appear which contains an error message informing the user that no devices are configured.

This window provides information about items being printed and access to job and printer control. The following information is provided for each device:

- Device name.
- Device status.

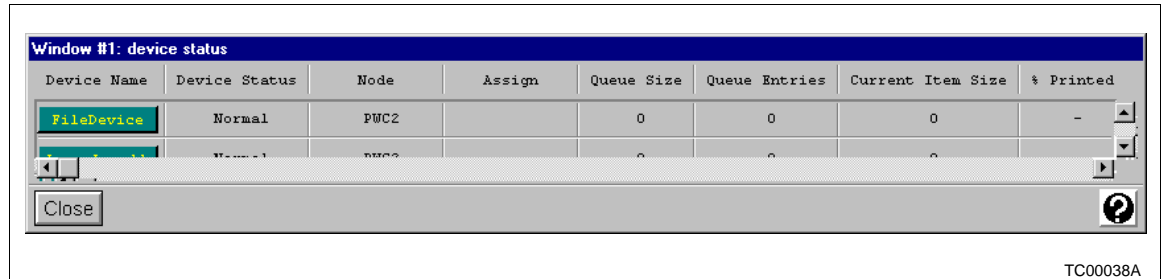

Figure 3-12. Device Status Window

- Node.
- Active backup unit name (Assign).
- Queue size.
- Number of queue entries.
- Size of current job.
- Percent of current job printed.

### PRINTER QUEUE CONTROL

The column labelled *Device Name* contains a button for each device which has been defined via *Printer Assignment* configuration (**Personal Work Center 90 Configuration** instruction). The name of the device appears on the face of the button. The color of the button indicates the status of the device:

- *Green* indicates the device is operating *Normally*.
- *Red* indicates the device has *Failed*.
- *Yellow* indicates the device has been placed in *Suspend* mode.

**NOTE:** When the button color changes to indicate the device status, the text on the button also changes color so that it remains visible. The text color has no other significance.

In addition to button color, the *Device Status* field to the right of each *Device Name* button provides status indication in text form, i.e., it will display the word *Normal*, *Failed* or *Suspended*.

When the *Device Name* button is pressed, the *Printer Queue Control* window (Figure 3-13) will be displayed.

The first item in the *Printer Queue Control* window is the name of the device. Below this identifier the window is divided into two main sections. The first of these is labelled *Cancel* and contains two buttons:

- *Current Item*.
- *All Items*.

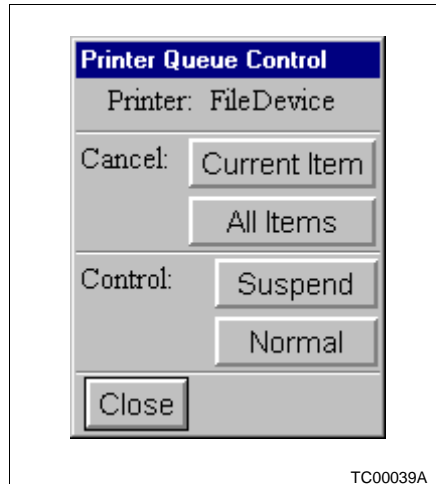

Figure 3-13. Printer Queues Control Window

Click on *Current Item* to terminate the job which is active in the device. Click on *All Items* to terminate the active job and delete all other entries from the queue for that device.

Canceling a job removes its entry from the print queue; however, any portion of the job which has already been loaded into buffer space (in any relevant device, such as the printer, the PWC90 console, and so on) will be printed. Therefore, it is not unusual for a few pages of a job to print out after the job has been canceled.

The next portion of the window is labelled *Control*, which also contains two buttons:

- *Suspend*.
- *Normal*.

Click on *Suspend* to suspend operation of the device (*Suspend* mode). When this action is performed, processing of any jobs in the queue will be completed, but no new jobs will be accepted in the queue. Click on *Normal* to return to normal operation.

Click on *Close* to close the *Printer Queues Control* window.

---

### **PRINTER QUEUE INFORMATION**

The *Node* field on the *Device Status* window displays the name of the node which is currently serving the print device.

When a device is operating normally, nothing is displayed in the *Assign* field. When a device fails, the *Assign* field will display the device name of the backup unit which is actually servicing the queue for the failed device. Backup device

assignments are configured via *Printer Assignment* (refer to the ***Personal Work Center 90 Configuration*** instruction).

The *Queue Size* field displays the number of bytes in all jobs in the device's print queue, while the *Queue Entries* field indicates the number of jobs in the queue. The *Current Item Size* indicates the size, in bytes, of the job which is currently active. The *% Printed* field indicates what portion of the currently active job has been completed.

---

## SECTION 4 - HIERARCHICAL PROCESS DISPLAYS

---

### INTRODUCTION

This chapter describes the hierarchy of displays that provide the user with process information. This hierarchy consists of summary, group, faceplate and point displays. The PWC90 console also provides the means to create custom displays which can be used in place of the standard displays. If the hierarchical displays on your PWC90 console are different from those described here, it is possible that custom hierarchical displays are in use on your system. Consult your system administrator for information on local custom displays.

With an operator window open and given keyboard focus, press one of these keys (**F2** for a summary display, **F3** for a group display, and **F4** for a point display.) A pop-up window will appear, which allows the entry of the index number of the display to be viewed. This pop-up window varies with the type of display selected.

Alternatively, the mouse can be used (instead of a keyboard key) to display this pop-up window. Again, an operator window must be open; use the mouse to click on the *Select* option on the operator window menu bar. This action both confers keyboard focus on that window, and causes a pull-down menu to appear, as shown in Figure 4-1.

Click on *Summary*, *Group* or *Point* item to display the appropriate pop-up window.

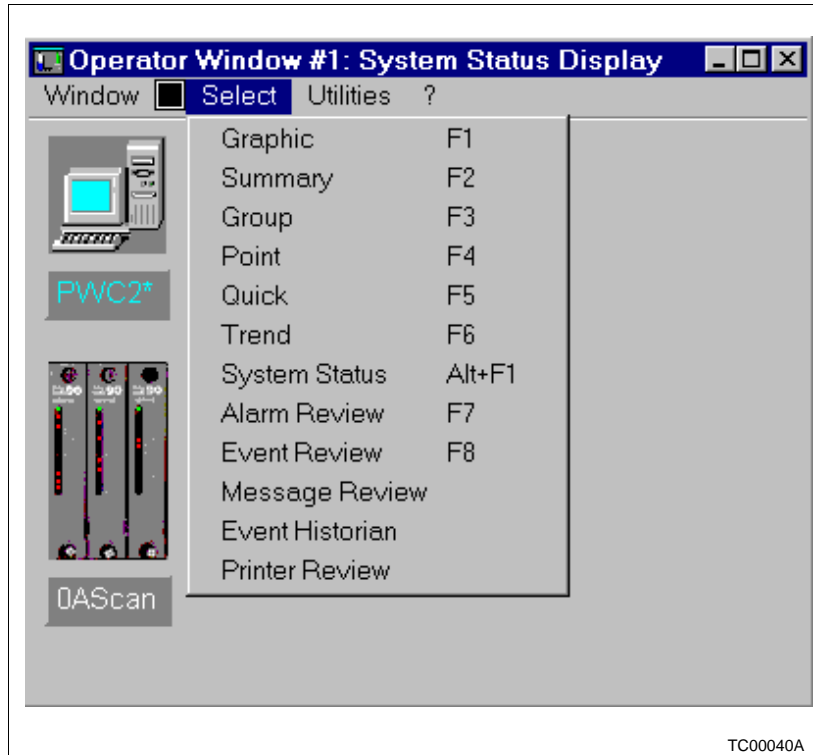

Figure 4-1. Operator Window Select Menu

**SUMMARY DISPLAY**

Pressing **F2** or clicking on the *Summary* option causes the pop-up window shown in Figure 4-2 to appear.

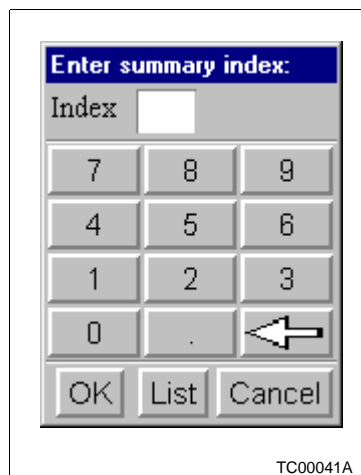

Figure 4-2. Summary Index Entry Window

The top portion of this window contains an entry box labelled *Index*.

Below the entry box is a keypad which includes the index numbers zero through nine, a decimal point, and a **Backspace**. Enter the desired number using either the number keys followed by **Return** on the keyboard or by using the mouse to click on the desired index number(s) in the keypad area of the window. When using the mouse, click on *OK* to complete the operation, or click on *Cancel* to exit without making a selection.

The summary index entry window also contains a button marked *List*. Click on *List* to call up the *Select Summary* window (Figure 4-3).

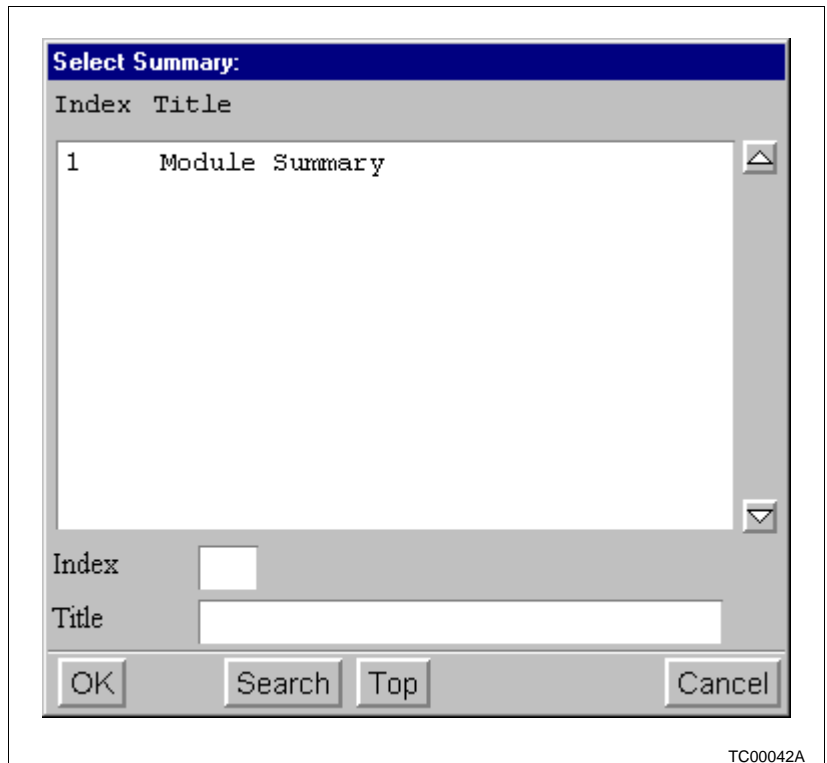

Figure 4-3. Select Summary Window

This window provides a list box which contains a scrollable list of all summaries configured on the system; it also contains an entry box labelled *Index*. Click on an item in the list box to select it. The index number of that summary will automatically appear in the *Index* entry box. If desired, this number can be entered or changed manually by clicking on the entry box, then entering an index number from the keyboard.

To locate a summary for which only the title (or a portion of the title) is known, enter the known string in the entry box labelled *Title*, then click on *Search* at the bottom of the window. The first summary title containing an instance of that string will be placed at the top of the list box and highlighted.

To place *Summary Display 1* at the top of the list box, click on *Top*.

**Using the Summary Display**

A summary display provides an overview of 24 groupings of points, arranged in six rows of four blocks, each representing a group (Figure 4-4). At the top of the screen a legend for the 24 groups is displayed. The legend can consist of up to 48 characters. There are 128 summary displays available.

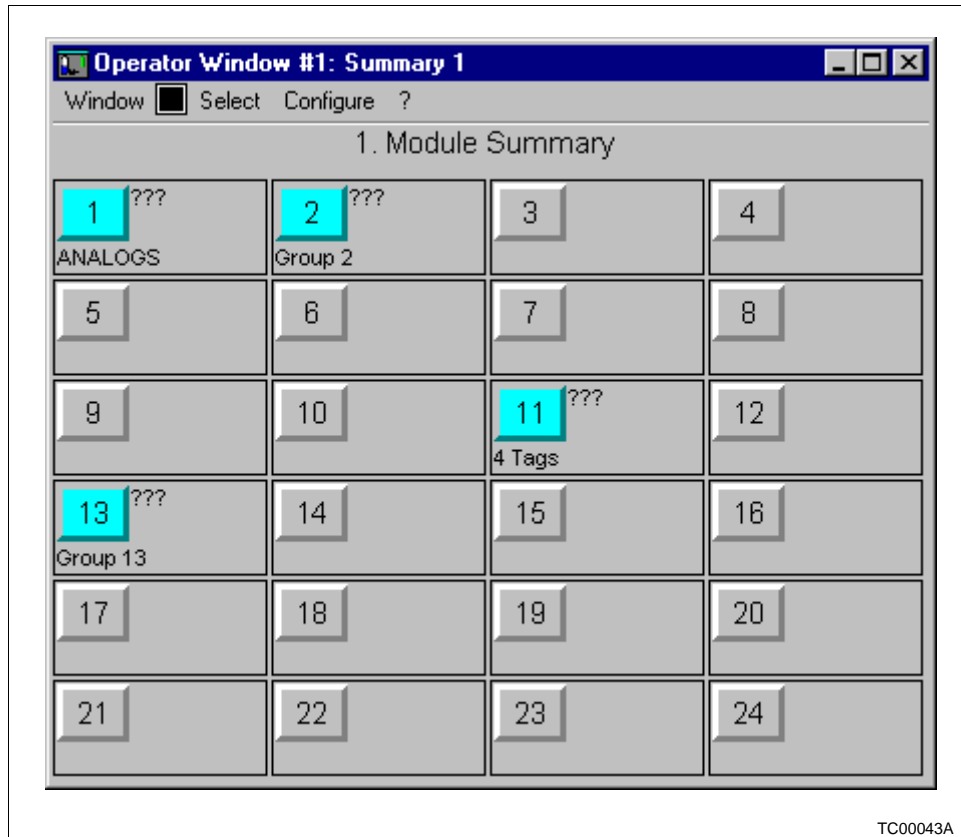

Figure 4-4. Summary Display Example

A pushbutton is located in the upper left corner of each block on the summary display; this pushbutton contains the number (1 through 24) of the group represented by the block. The color of the pushbutton provides information regarding the status of the group, as described in Table 4-1.

Table 4-1. Group Status Conditions

Color	Text	Status
Red	Unack. Alarms	At least one tag in the group is in an alarm state, and the alarm is unacknowledged.
Yellow	(Unack.)	At least one tag in the group was previously in alarm, and, although the tag in alarm has returned to normal, the alarm has not been acknowledged.

Table 4-1. Group Status Conditions (continued)

Color	Text	Status
Yellow	Alarms	At least one tag in the group is in an alarm state, and the alarm has been acknowledged.
Cyan	???	The status of at least one tag in the group is unknown because the tag cannot be accessed from the INFI 90 OPEN system.
Green	[no text]	All tags in the group are accessible, are in normal state or alarm inhibit state, and no alarms need acknowledgment.
Gray	[no text]	If the group has not been configured, the pushbutton appears in gray.

Click on this pushbutton using the left mouse button to display the *Group* window (Figure 4-5), which provides access to the group display or to individual point displays.

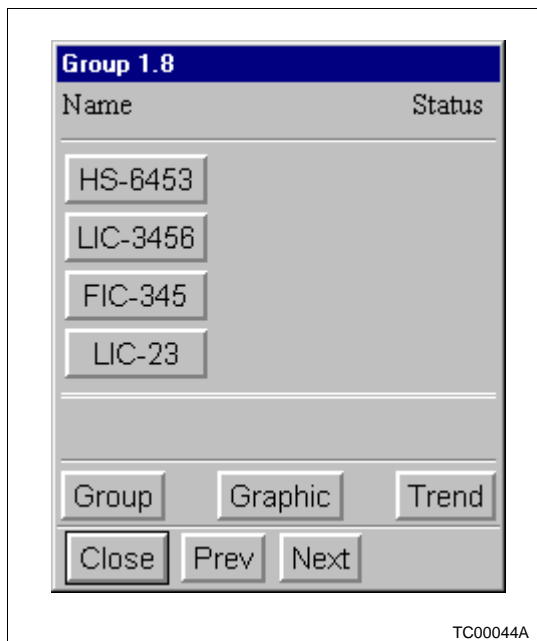

Figure 4-5. Group Information Window

The *Group* window provides an overview of a group of points, listing both the point name and the status of each point. From this window, it is possible to go directly to any one of the following displays:

- Group display for the group.
- Point display for any tag in the group.
- Graphic display assigned to the group.
- Trend display assigned to the group.
- *Next* or *Previous* group display.

The top portion of the *Group* window contains a list of tags assigned to the group. The tagname for each point is located on the face of a pushbutton. To the right of each tagname pushbutton is a field which reports the status of the tag. To call up the point display for a point in the group, click on the button which contains the tagname of the point. To call up the graphic or trend display assigned to the group, click on *Graphic* or *Trend* located below the point information area.

To call up the group display, click on *Group* on the *Group* display, or on *OK*.

To view the group display for the previous group in the summary display, click on *Prev*; to view the group display for the next group, click on *Next*. Wrap is provided between the first and last available groups; groups which have not been configured are ignored.

Alarms cannot be acknowledged from the summary display, nor can they be acknowledged from the *Group* window. The *Window Ack* key has no effect when the window with focus contains a summary display. Alarms can be acknowledged from group, point, graphic and alarm review displays, or from the mini-alarm window.

To exit the *Group* window without selecting a group display, click on *Cancel*.

---

## GROUP DISPLAY

A group display presents operational data for up to eight tags simultaneously (Figure 4-6). Points are assigned to the group display according to their location in the *Group Info* window. Any tag in the INFI 90 OPEN server database can be assigned to a group display.

All available process control actions (e.g., *Auto*, *Manual*, *Run*, *Reset* and so on) and alarm acknowledgment for tags in a group can be performed from the group display on a point by point basis. Equal access is available at all times to every display button on every tag on the group display; it is not necessary to select a particular faceplate prior to using the control features available for it. Clicking on a button automatically selects the button and faceplate.

Although all control features can be used from the group display, parameters of a tag must be changed from its point display.

**NOTE:** Operation of the ZOOM item on the group display menu bar is identical to that of the ZOOM item found on graphic displays.

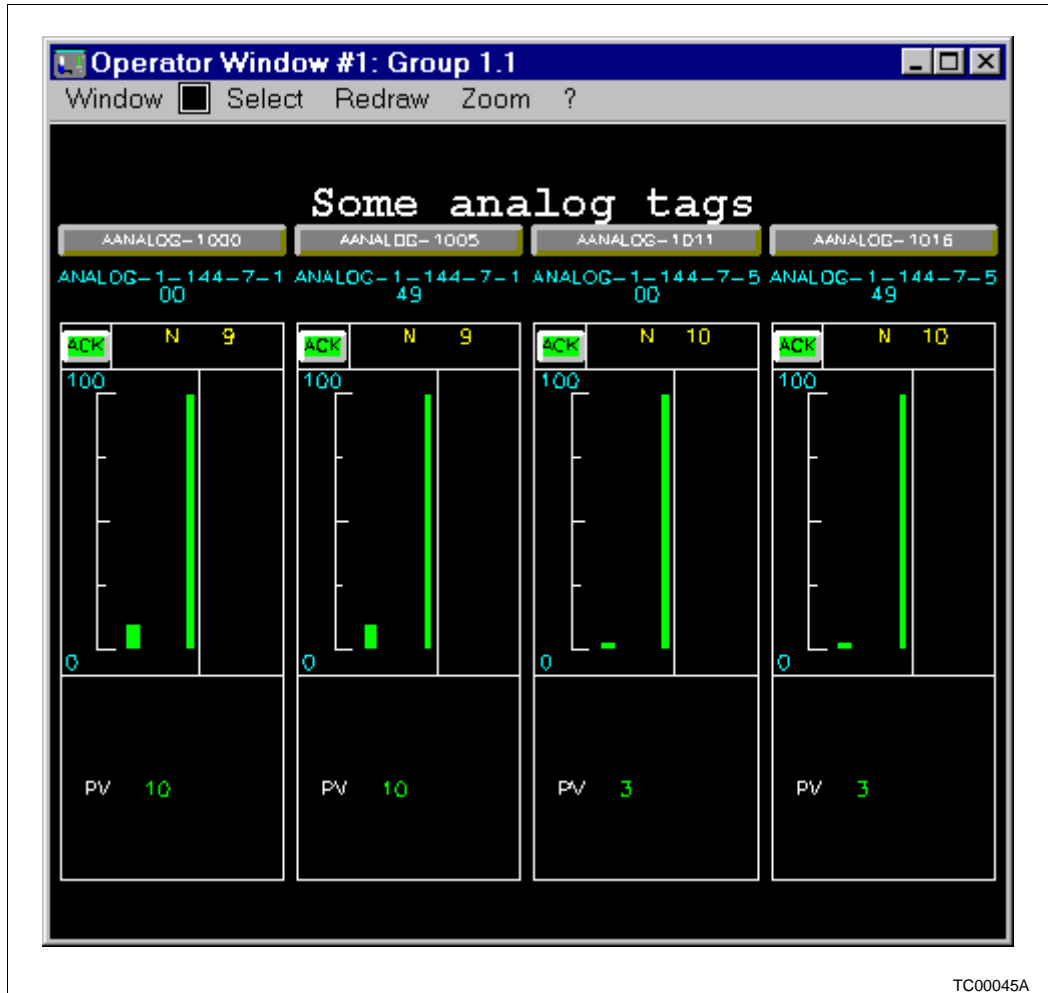

Figure 4-6. Group Display Configured for Four Tags

**Accessing the Group Display**

In addition to access via the *Group* window, it is also possible to call up a group display directly from any operator window via the *Select* menu (Figure 4-1) by clicking on the *Group* item, or by pressing the **F3** on the keyboard. Either of these actions will cause a pop-up window (Figure 4-7) to be displayed:

To call up a group display using this window, enter the summary index number, a period (.), and then the group index number in the text entry box labelled *Index*. The keypad and *List* button on this display are identical in function to those used in the summary index window (Figure 4-2).

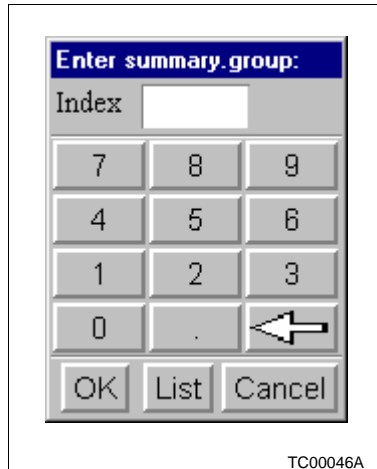

Figure 4-7. Group Selection Window

---

**Group Legends**

At the top of the group display is a group legend of up to 48 characters. The main area of the display is divided into four, six or eight blocks; the information within each block relates to one tag. There are 3072 group displays available.

---

**Faceplate Tagnames**

At the top of each block on the group display is a button which contains the first 12 characters of the faceplate tagname. If the tagname is longer than 12 characters, the last (twelfth) character displayed in the tagname is a tilde (~). Click on this button to call up the point display for that tagname in the operator's window. (The complete tagname appears on the point display.)

---

**Tag Descriptions**

The Tag Descriptions is displayed below the tagname in three lines of up to 12 characters each, for a total of 36 characters. Each line of 12 characters is centered. If it is necessary to truncate the description (which can be configured to a maximum of 48 characters), the thirty sixth character is a tilde (~). (The complete description appears on the point display.)

---

**Status Area**

Each faceplate on the group display contains a status area, located directly below the tag description (Figure 4-8). The status area is composed of two lines and an indicator area.

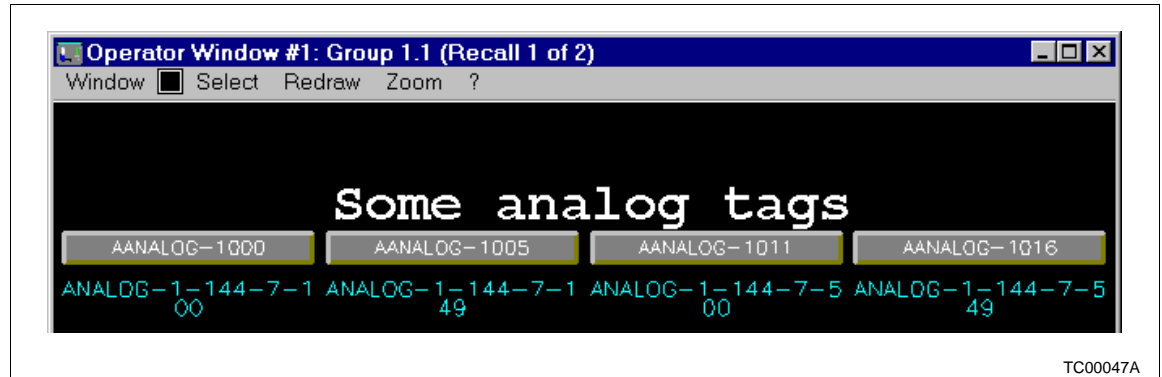

Figure 4-8. Tagname and Status Areas from a Group Display

**Status Messages**

Tag status messages are displayed in the first line of the status area. Depending on the type of tag displayed, this message can be an alarm or other condition of the tag. The area number is displayed to the right of the alarm status descriptors. Detailed descriptions of status messages are provided in Table 4-2.

Table 4-2. Alarm Status Descriptors (Two Character)

Descriptor	Description	Tag Type
Blank	No alarm	All
3H	Three-high alarm	DAANG
2H	Two-high alarm	DAANG
H	High alarm	ANALOG, DAANG, STATION
L	Low alarm	ANALOG, DAANG, STATION
2L	Two-low alarm	DAANG
3L	Three-low alarm	DAANG
HD	High deviation alarm	DAANG, STATION
LD	Low deviation alarm	DAANG, STATION
HR	High rate of change alarm	DAANG
LR	Low rate of change alarm	DAANG
N	Return to normal from alarm	All
A	Digital	DIGITAL, INTDIG, RCM, RMCB, DD, MSDD, DADIG, TEXTSTR
*	Bad quality <sup>1</sup>	All
!!	Alarms suppressed	DAANG, DADIG, TEXTSTR

---

### ***Alarm Indicator***

In addition to a status message and mode, each faceplate status area contains an ACK[nowledge] button, located on the left side of the area. This button appears when an unacknowledged alarm exists for the point. The color of the button reflects the current status of the tag:

- Yellow for high, low or digital alarm.
- Green for return to normal.

A DAANG tag has extra colors:

- Red for three-high or three-low alarm.
- Orange for two-high or two-low.

Click on ACK to acknowledge the alarm or, if the operator window containing the alarm indicator has keyboard focus, press **Alt-F10** on the keyboard to acknowledge all tags in the group which are in alarm.

If no unacknowledged alarms exist for the tag, the ACK button is not visible.

---

### ***Process Display Area***

Directly below the status area for each faceplate on the group display, the process display area is arranged in one of several forms, according to the type of module being described.

Analog tag types (Analog, Analog Export, DAANG, RMSC and Station) are displayed in a form which includes a process bar in the process display area. The length of the process bar corresponds to the value of the process variable (PV) atom and is displayed as a percentage of full scale; the upper and lower limits of the range of the process variable are reflected in the values at the top and bottom of the scale located at the left of the process bar. These limits are presented in a fixed precision format, with one digit to the right of the decimal point.

Below the process bar, the data displayed includes the values of the process variable for all types of analog tags, the value of the setpoint and setpoint controls (if applicable), controller output indicator, the value of the output, and output controls (if applicable). The number of digits used to display a value (including the decimal point) and the size of the group display (whether it is configured for four, six or eight tags) can affect the appearance of the display. There are no restrictions on the number of digits which can be configured to display a value; however, if the format contains too many digits, part of the displayed value may overlap onto the portion of the screen occupied by the adjacent point's display. To avoid this, the

recommended combinations of points and formats are shown in Table 4-3.

Table 4-3. Recommended Point Format

Points	Formats
4 tag group display	9 digits (including decimal point)
6 tag group display	6 digits (including decimal point)
8 tag group display	4 digits (including decimal point)

The C\_RANGLO (Base Value) and EB\_SPAN (Span) atoms define the range of values which the variable can assume. The EB\_DECDIG (Decimal Digits atom specifies the number of digits to be displayed to the right of the decimal point. For example, the following configuration ensures that the process variable will contain no more than six digits, including decimal point. (The widest value that will be displayed is 100.00):

```
C_RANGLO: 0
EB_SPAN: 100
EB_DECDIG: 2
```

If the instrument range includes negative values, a place must be allowed for the minus sign. (The plus sign is not shown for positive values.) For example, the following configuration ensures that the process variable will contain no more than six digits, including decimal point and sign. (The widest value that will be displayed is -100.0):

```
C_RANGLO: -100
EB_SPAN: 100
EB_DECDIG: 1
```

If control of the setpoint or output are available for the point, a button containing the legend *SP* or *OUT* will appear to the left of the setpoint or output value. Clicking on one of these buttons will cause a value entry window to appear; this window will contain an entry box and keypad display, such as the one shown in Figure 4-9. Enter the desired value for the setpoint or output value in the entry box (using either the pop-up keypad or the keyboard), then click on *OK* or press **Return** to complete the operation, or click on *Cancel* to exit the *Value Entry* window without entering a new value.

The following paragraphs characterize the different types of modules as they appear in the process display area of the group display.

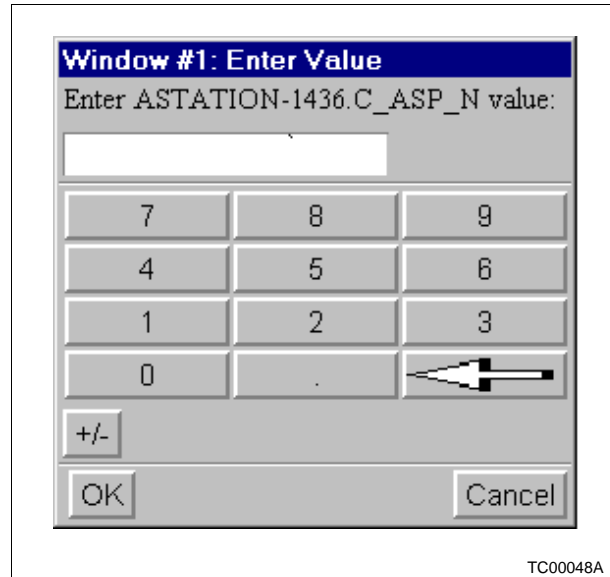

Figure 4-9. Value Entry Window

## PROCESS CONTROL FUNCTIONS

Control functions provide the ability to monitor individual process variables and devices, and provide the ability to perform manual and automatic mode device control. Process information is received in exception reports from function blocks configured in a Multi-Function Processor module. The control ability allows changing process conditions from the PWC90 console by initiating changes to the Multi-Function Processor module. A Multi-Function Processor module receives input from and sends output signals to the process through termination units connected to process devices and stations.

**NOTE:** Control abilities can be limited to specific personnel by defining password security. The security level of a user must give control access rights before any control can be initiated.

### Control Faceplates

Dynamic faceplates for the different types of control tags can be either standard or user created. Standard control faceplates are provided. A control faceplate can be a fixed part of a display or it can be called as a pop-up faceplate. The same control actions can be performed from a fixed faceplate as can be performed from a pop-up faceplate. This assumes that the symbol file used for the fixed faceplate is also the same one used for the pop-up faceplate, or the pop-up faceplate, if different, has all the same capabilities as the fixed faceplate built in.

**Control Tags**

Control tags provide access to control function blocks within a module. The access can be used to manually initiate process changes and to monitor the results of both automatic and manual control operations. Automatic refers to operation being performed under Multi-Function Processor module execution. Manual refers to those actions initiated after taking a function block out of automatic Multi-Function Processor control. Table 4-4 lists the control tags and the function codes (FC) they associate with. Refer to the **Function Code Application** instruction for a description of these function codes and their specifications.

Table 4-4. Control Tags

Tag	Function Code <sup>1</sup>
DD	Device driver, FC 123.
MSDD	Multi-state device driver, FC 129.
RCM	Remote control memory, FC 62.
RMCB	Remote motor control, FC 136.
RMSC	Remote manual set constant, FC 68.
STATION	M/A station (basic), FC 21; M/A station (cascade), FC 22; M/A station (ratio), FC 23; and control station, FC 80.

**NOTE:**

1. Information reported by these function codes can be incorporated into any display. This information is not restricted to faceplate symbols only.

**Control Inhibit**

Control can be inhibited at the module level. This prevents control changes from the PWC90 console. The inhibit status is checked when a control action is initiated. If inhibited, an invalid action message appears. Table 4-5 shows the inhibit indications that appear for control tags.

Table 4-5. Control Inhibit Indications (Control Tags)

Tag	Control Inhibit Indication
DD	REMOTE or AUTO
MSDD	AUTO
RCM	NP (No Permissive)
RMCB	Zero state permissive
RMSC	T (Tracking)
STATION	COTR (control output change inhibit) LOCK (mode change inhibit) SPTR (set point change inhibit).

**Common Control Faceplate Attributes**

The standard faceplates share some common attributes:

- Alarm status/quality/group.
- Red tag descriptor.
- Tag descriptor.
- Tag name.
- Alarm acknowledge button.

These attributes can be incorporated into any graphic or custom faceplate.

**Alarm Status/Quality/Group**

An alarm status/quality/group field displays alarm status and is used for alarm processing. In standard faceplate symbols, this field accommodates five characters.

**NOTE:** Only available for points capable of generating alarms.

From left to right, the first two character positions are the alarm status. A descriptor in these positions identifies the last alarm threshold that a point passed as determined and exception reported by the Multi-Function Processor module.

The third character position is the quality field. This field identifies the quality associated with a process value or state and the operating status for the tag.

**NOTES:**

1. Operator actions on the PWC90 console trigger disestablished, substitute, and inhibit status indications (i.e., operating parameters functions). Multi-Function Processor modules report good, suspect, and bad in exception reports.
2. Control cannot be performed for any tag reporting bad quality or off scan.

The last two character positions identify the alarm group to which the tag is assigned. The field appears as *1* through *64*.

An alarm status/quality/group field appears as:

*2H 10*

This indicates the point has passed the two-high threshold set in the Multi-Function Processor module, the module has determined that it is receiving good data for the point, and the tag defining the process point is part of alarm group ten.

Refer to **PROCESS ALARMS** in Section 8 for an explanation of alarm processing, alarm conditions, and alarm indications.

**Red Tag Descriptor**

A red tag descriptor (*RT*) identifies a process point as being red tagged. Red tagging performed from the PWC90 console does

not prevent a process device from operating. The PWC90 console can be set up to either display red tag status and disable control actions from the PWC90 console or to display red tag status only.

A Multi-Function Processor module reports red tag status in an exception report. Red tag status is available for the following control tags:

- DD.
- RMCB.
- MSDD.
- STATION.
- RCM.

<b>Tag Descriptor</b>	A tag descriptor can be up to 40 characters and is defined during tag configuration. Normally, this descriptor explains the purpose of the tag (process point).
<b>Tag Name</b>	A tag name can be up to 16 characters and is defined during tag configuration. This identifies the tag defined to allow monitoring and control of the process point.
<b>Alarm Acknowledge Button</b>	The alarm acknowledge button appears when the point controlled by the faceplate is in an alarm state. To acknowledge the alarm click on the ACK button.

---

**Loop Control**

A station faceplate allows adjustment of a control loop. A station tag defined for the station function block controlling the loop and a station faceplate are required for loop control. The tag and faceplate allow monitoring and controlling of the loop from the PWC90 console.

---

**STATION FACEPLATE**

A station faceplate is a representation of an analog control station. The same functions that can be performed and the same values that can be displayed on an analog control station physically located in the plant can be performed and displayed on the PWC90 console using this faceplate. The station presents a detailed on-line display of a single process loop. A station tag is required to acquire process values from a manual/auto (M/A) station block in a Multi-Function Processor module and to direct control.

Figure 4-10 details the information presented in a station faceplate.

The station block level (local or computer) and mode (manual or auto, and basic, cascade, or ratio) determines the operations that can be performed from the PWC90 console. The level and

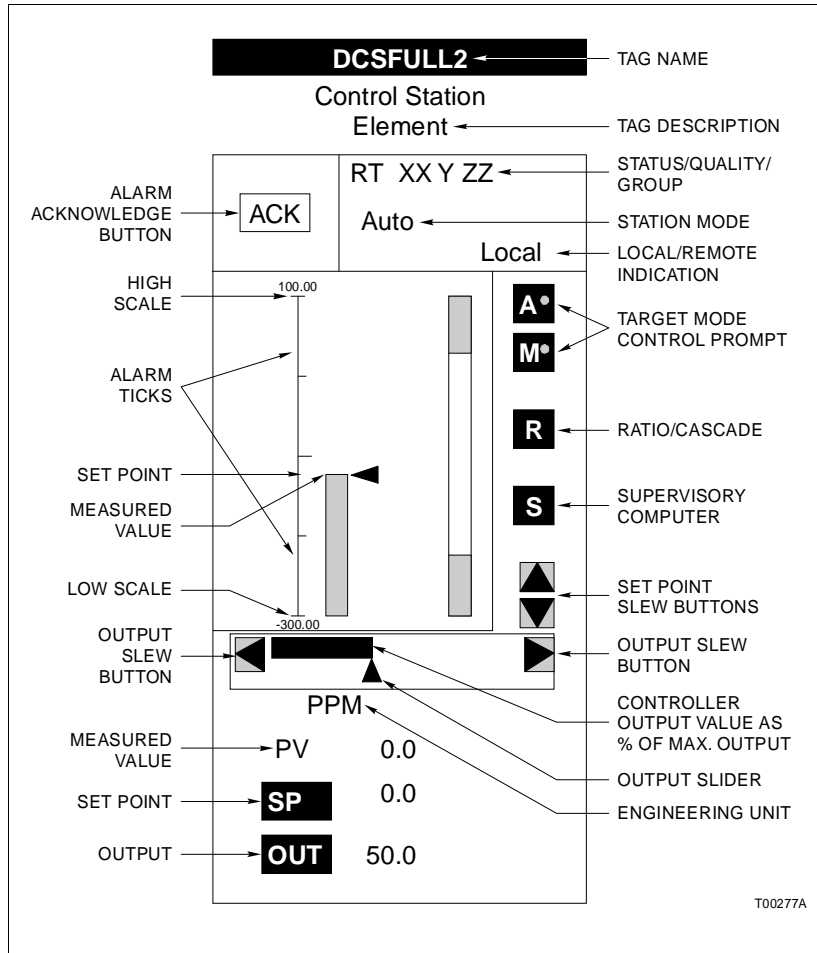

Figure 4-10. Control Station Faceplate

mode can be changed from the PWC90 console.

A station function block exception reports the dynamic values, mode, alarm status, and quality that display in a station faceplate. The following information explains the attributes that relate to a Station tag and can be incorporated into any graphic or custom faceplate. Figure 4-10 shows the location of the attributes described.

**Alarm Bar** The alarm bar provides a scale reference to easily determine when the PV dynamic bar passes an alarm limit. These bars use colored areas to indicate the position of the high and low alarm limit points.

**Controller Output Value Dynamic Bar** The controller output value (CO) dynamic bar shows the control output as an expanding or contracting dynamic bar. The bar expands horizontally from the baseline mark on the scale as the control output increases as a percentage and contracts back to the baseline mark as the control output decreases.

<b>Output</b>	The output is the current value (in percent of output) being output from the station function block. The control output can be adjusted from the PWC90 console.
<b>Engineering Unit Descriptor</b>	The engineering unit descriptor (EUD) shows the unit of measurement for the process variable and set point. The station function block reports an EUD index number to select the appropriate engineering unit descriptor. Station faceplates that present the process variable and set point values are in this unit of measurement.
<b>High and Low Scale Limits</b>	The high and low scale limits are the maximum and minimum value associated with the top line and baseline of the static scale respectively. The limits are derived from the zero and span configured in the station function block for either the process variable or the set point depending on the station faceplate configuration.
<b>Process Variable and Set Point Scale</b>	The process variable (PV) and set point (SP) scale is a static display element used for reference. It is built as a fixed part of the faceplate.
<b>Process Variable Dynamic Bar</b>	The PV dynamic bar shows the process variable as an expanding or contracting dynamic bar. The bar expands vertically from the baseline mark on the scale as the process variable increases in value and contracts back to the baseline mark as the variable decreases.
<b>Process Variable Value</b>	The PV value is the current input value being exception reported by the station function block. The process variable comes from the function block providing station block control, usually a PID block.
<b>Set Point Value</b>	The SP value is a dynamic moving value accompanied by a dynamic pointer. The displayed value and the pointer position on the scale indicate the current set point being exception reported by the station function block. The set point can be adjusted from the PWC90 console.
<b>Station Mode</b>	The station mode is the current operating condition for the station. The station operates in either manual or automatic mode. It also operates in basic, cascade, or ratio mode.  When in automatic mode operation, the station mode appears as <i>AUTO</i> . In this mode, the Multi-Function Processor module automatically controls the process. The station can be set to either cascade or ratio operation and the set point and ratio index value can be adjusted while in this mode. Whether a station block can be toggled between basic and ratio operation or basic and cascade operation depends on the type of station block. The station mode field indicates <i>RATIO</i> or <i>CASC</i> if either is selected.

When in manual mode operation, the station mode appears as *MANUAL*. The control output value can be adjusted while in this mode.

Table 4-6 lists the indicators that can appear in the station mode field. The type of indication depends on the escape command used during station faceplate creation.

Table 4-6. Station Modes

Mode	Description
AUTO	Automatic mode operation. The set point and ratio index can be adjusted from the console.
MANUAL	Manual mode operation. The control output can be adjusted from the console.
BYPASS	Bypass mode operation. Control cannot be initiated from the console.
CASC	Cascade operation. Click on B or C to toggle between basic and cascade operation.
RATIO	Ratio operation. Click on B or C to toggle between basic and ratio operation. Ratio index can be changed while in this mode.

**NOTE:** A station faceplate may not have a separate station mode field and tracking indicator field. Depending on the escape commands used during faceplate creation, the faceplate may display both the tracking and mode indicators in the station mode field.

---

## STATION CONTROL

There are three types of stations, each controllable from the PWC90 console: basic, cascade, and ratio. A **basic station** allows a user to change a set point and provides manual or automatic transfers. Also, a **basic station** allows control output adjustment in manual control mode. A **cascade station** provides the same functions as a basic station plus an additional cascade mode that allows the set point to be controlled by another process variable. A **ratio station** provides the same functions as a basic station, but differs in its method of set point generation. A ratio adjustment factor determines the set point as a ratio of a second uncontrolled (wild) variable. The station can be put into ratio mode from the PWC90 console to adjust the ratio factor. Any type of station function block can operate as a basic station.

Station control allows changing the mode, set point, ratio index, and control output of a control station by manipulating a station function block in a Multi-Function Processor module.

---

### Changing the Mode

A mode change may be required to perform a desired control action. The station must be in *MANUAL* control mode to adjust the control output. It must be in *AUTO* mode to toggle the station to ratio or cascade operation.

Click on Auto(A) or Manual(M) to select between auto and manual operation. The station cannot be toggled to automatic mode if the manual interlock is set (*LOCK*).

Press Cascade(C) while the station is in *AUTO* mode to select Cascade operation. The station function block must be capable of cascade operation for this key to function for the station.

- **or** -

Press Ratio(R) or Basic(B) while the station is in *AUTO* mode to select between basic and ratio operation. The station function block must be capable of ratio operation for this key to function for the station.

---

### ***Changing the Set Point***

The set point can be adjusted as long as set point tracking is not enabled. To change the set point:

1. Verify that the station is not in set point track mode (*SPTR*). The station function block determines in which station modes set point tracking is to be implemented. The choices are to implement set point tracking in manual mode only or to implement it in both automatic and manual mode.
2. The value can be changed using one of three methods. Click on *SP* and enter a value in the popup window with the keyboard or by using the mouse to enter the numbers, drag the pointer along the set point bar to the desired position, or press the ramp keys to increment or decrement the value.

**NOTE:** The value automatically ramps slowly up or down when using the arrow keys or the pointer. When entered in the popup menu, changes do not start until *OK* is clicked. Click on *Cancel* to exit without change.

The dynamic pointer will move up or down the scale to reflect the entered value.

---

### ***Changing the Ratio Index***

The ratio index can be changed while the station is in *RATIO* mode. To change the ratio index:

1. Verify the station is in ratio control mode (*RATIO*). If not, change the mode.
2. The value can be changed using one of three methods. Click on *RI* and enter a value in the popup window with the keyboard or by using the mouse to enter the numbers, drag the

pointer along the ratio index bar to the desired position, or click the slew arrows to increment or decrement the value.

**NOTE:** The value automatically ramps slowly up or down when using the arrow keys or the pointer. When entered in the popup menu, changes do not start until *OK* is clicked. Click on *Cancel* to exit without change.

The dynamic pointer will move up or down the scale to reflect the entered value.

---

### ***Changing the Control Output***

The control output can be changed while the station is in *MANUAL* mode. To change the control output:

1. Verify the station is in manual control mode (*MANUAL*). If not, change the mode.
2. The value can be changed using one of three methods. Click on *OUT* and enter a value in the popup window with the keyboard or by using the mouse to enter the numbers, drag the pointer along the output bar to the desired position, or click the slew arrows to increment or decrement the value.

**NOTE:** The value automatically ramps slowly up or down when using the arrow keys or the pointer. When entered in the popup menu, changes do not start until *OK* is clicked. Click on *Cancel* to exit without change.

The dynamic pointer will move up or down the scale to reflect the entered value.

---

### ***Device Control***

A process device is controlled by manipulating the control configuration in the Multi-Function Processor module. The faceplates used for device control give feedback to verify when changes requested from the PWC90 console are actually implemented by a device.

---

### ***REMOTE CONTROL MEMORY FACEPLATE***

The remote control memory (RCM) faceplate represents a remote control memory function block in a Multi-Function Processor module. This function block provides a set and reset, flip flop memory to control a process device. An RCM tag is required to monitor and control the output of this function block.

Figure 4-11 details the information presented in a remote control memory faceplate.

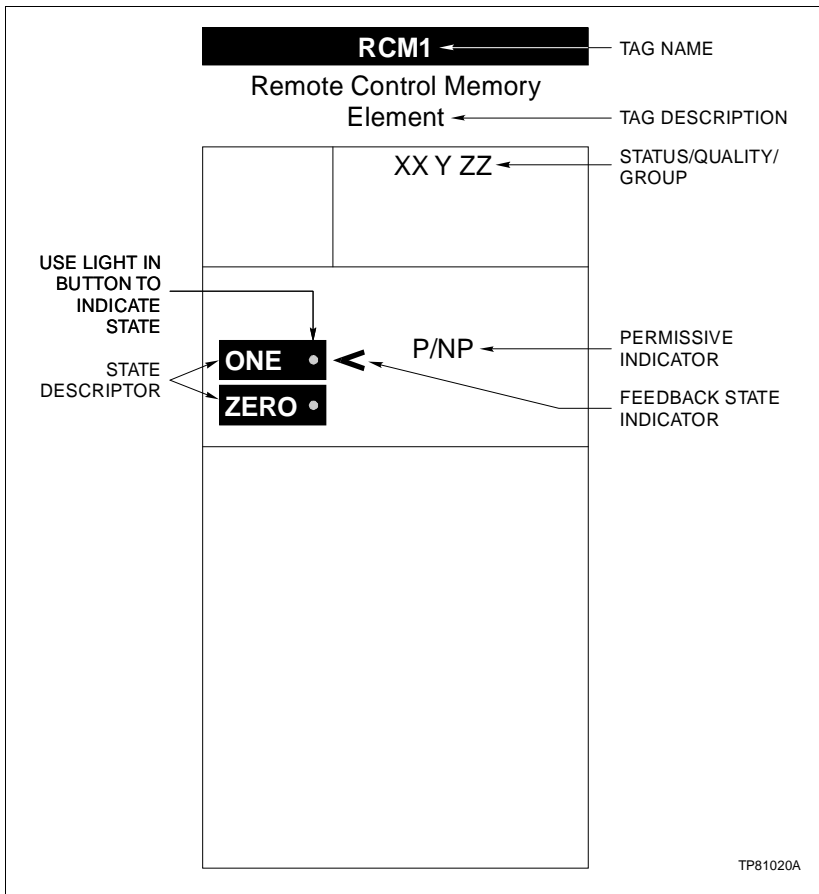

Figure 4-11. Remote Control Memory Faceplate

The remote control memory block exception reports the current state, feedback state, permissive state, override status, alarm status, and quality presented in the RCM faceplate. The following information explains the attributes that relate to an RCM tag and can be incorporated into any graphic or custom faceplate. Figure 4-11 shows the location of the attributes described.

**Feedback State Indicator**

The feedback indicator gives a feedback indication to verify the change in state of a device and to show its current output state. The arrow positions at either the one or zero state as soon as feedback is returned.

**One State Descriptor**

The one state descriptor is text that describes a one state (logic one) output of the RCM function block. This descriptor is the ONE state descriptor defined in the database for the tag.

**Output Indicator (Red Dot)**

The output indicator (Red Dot) position identifies the requested logic state to be output by the RCM block. For example, the output is a logic one when it is in the one state descriptor.

**Permissive Indicator**

The permissive indicator shows the status being reported as the permissive input to the function block. The block must be

in a permissive state to change the RCM function block to its one state (set). An *SP* identifies the RCM as being set to permissive. An *NP* indicates nonpermissive.

**Zero State Descriptor** The zero state descriptor is text that describes a zero state (logic zero) output of the RCM function block. This descriptor is the *ZERO* state descriptor defined in the database for the tag.

---

### ***RCM CONTROL***

RCM control allows changing the output of a remote control memory function block in a Multi-Function Processor module. The remote control memory block provides a set and reset signal to a process device. The RCM function block acts on one of two inputs to develop its output. The block accepts both a control configuration driven input and an input from the PWC90 console.

The two inputs are also differentiated by the type of input. The control configuration can initiate either a pulsed or sustained command to the block where the PWC90 console can only input a pulsed command. A sustained input, which remains in a set logic state, overrides any pulsed input. A pulsed input is a one cycle transition used to trigger a state change. In either case, the block maintains its current output even if the input is removed. The output remains in either a set or reset state until another command is received to change the output state.

A pulsed set command from the PWC90 console causes the block to output a logic one and a pulsed reset command causes a logic zero output. This occurs as long as the control logic is not providing a sustained input to the block. A change to the one state (set) can only occur when the RCM function block is set to permissive.

---

### ***Changing the Output State***

The RCM function block output can only be changed from the PWC90 console if the block is not in a nonpermissive (*NP*) condition. The block must be set to permissive (*P*) to change the state.

To change remote control memory output, Click:

One state output.

- **or** -

Zero state output.

The *red dot* indicates the current selection and will move to reflect the change. The feedback indicator will update after feedback is received from the process.

**REMOTE MANUAL SET CONSTANT FACEPLATE**

The remote manual set constant (RMSC) faceplate is the interface to a remote manual set constant function block in a Multi-Function Processor module. This function block inserts a constant value used in the process control configuration. An RMSC tag is required to both monitor and change the constant value provided by the block from the PWC90 console.

Figure 4-12 details the information presented in a remote manual set constant faceplate.

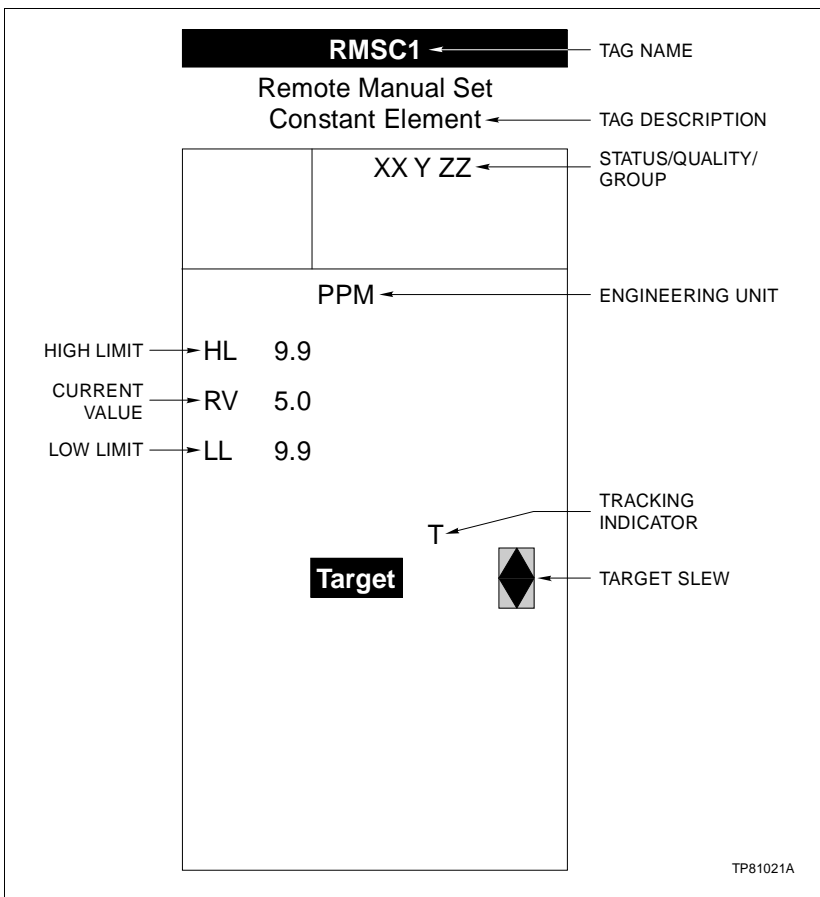

Figure 4-12. Remote Manual Set Constant Faceplate

The remote manual set constant block exception reports the constant value, high and low limits, tracking, alarm status, and quality that display in the RMSC faceplate. The following information explains the attributes that relate to an RMSC tag and can be incorporated into any graphic or custom faceplate. Figure 4-12 shows the location of the attributes described.

**Current Value**

The current value is the value that is currently set and is being reported as the constant value in the RMSC block. This value

can be changed from the PWC90 console if the tag is not in track mode.

**Engineering Unit Descriptor**

The engineering unit descriptor (EUD) shows the unit of measurement for the constant value. The RMSC function block reports an EUD index number to select the appropriate engineering unit descriptor.

**High and Low Limits**

The high and low limits are the maximum and minimum acceptable values. Only values that fall within this maximum and minimum range can be entered. An attempt to enter a value outside these limits causes an error message prompt.

**Tracking Indicator**

The tracking indicator appears when an RMSC block has been set to tracking mode. The control logic can force the block to track an alternate process variable. A *T* displays to identify tracking mode. The value cannot be changed when the block is tracking.

---

**RMSC CONTROL**

RMSC control allows changing a constant value in a remote manual set constant function block while a Multi-Function Processor module is in execute mode. A new value can be entered at any time except when the *T* (tracking) indicator is present.

---

**Changing the Value**

The RMSC block value cannot be changed while the block is in tracking (*T*) mode. The value can be changed using one of two methods:

1. Click on *TARGET* and enter a value in the popup window with the keyboard.

- **or** -

2. Use the mouse to press the slew arrows to increment or decrement the value.

The RMSC function block will not accept a value that is outside the high and low limits. When entering or ramping the value, the *TARGET* field is updated to reflect the change.

**NOTE:** The value automatically ramps slowly up or down when using the arrow keys. When entered in the popup menu change does not start until *OK* is clicked. Click on *Cancel* to exit without change.

**DEVICE DRIVER FACEPLATE**

The device driver (DD) faceplate represents a device driver function block in a Multi-Function Processor module. This function block provides an on or off signal to control a process device. A DD tag is required to both monitor and change the output provided by the block from the PWC90 console.

Figure 4-13 details the information presented in a device driver faceplate.

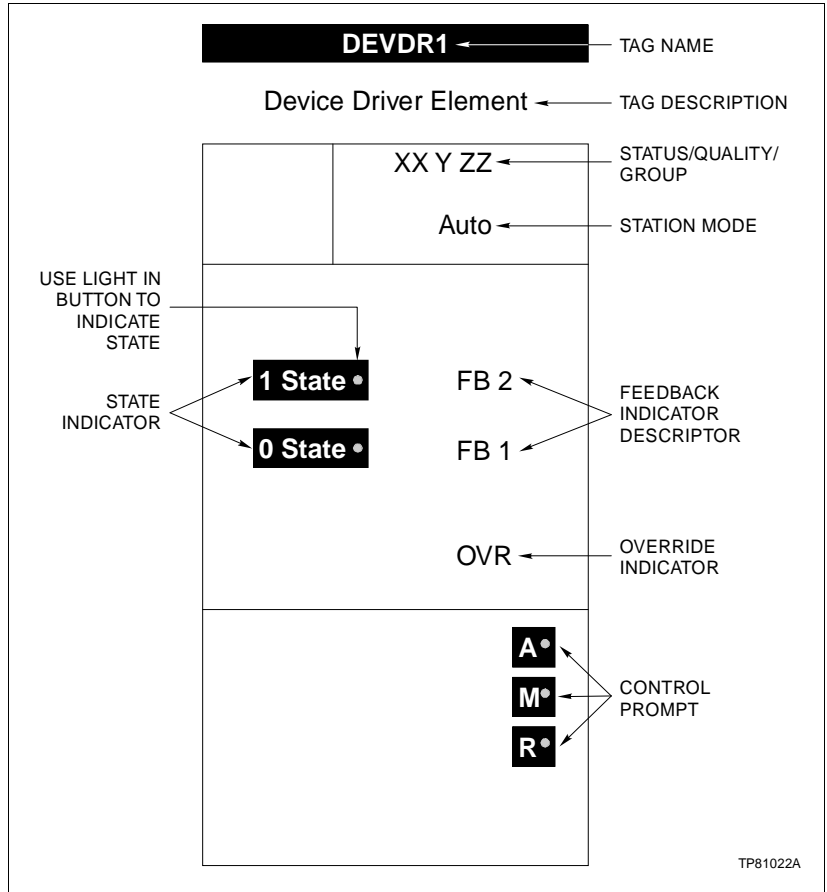

Figure 4-13. Device Driver Faceplate

The device driver block exception reports the current state, two feedback states, override status, mode, alarm status, and quality that display in the DD faceplate. The following information explains the attributes that relate to a DD tag and can be incorporated into any graphic or custom faceplate. Figure 4-13 shows the location of the attributes described.

**Feedback Indicator Descriptors**

The feedback one and two descriptors are text that describe the feedback signals input to the DD function block. The feedbacks will indicate either an on (logic one) or off (logic zero) state. The

faceplate displays the *ZERO* and *ONE* descriptors defined in the database for feedback one and two.

The feedback indications provide a verification of the actual state of the field device. When a change is initiated, the descriptors do not change until the block tests the feedback inputs. This does not occur until after a specified time elapses. The DD block also tests the feedback signals to determine if the output status is either good or bad.

**Station Mode** The mode shows the current operating condition of the block. A device driver block can be configured to operate in automatic mode only, automatic and manual mode, or remote mode only. The device driver function block specifications determine the acceptable operating modes.

While in *AUTO* mode, the control logic sets the output state of the device driver block. The block only provides an update to the display. *MANUAL* mode allows changing the output state from the PWC90 console. If the DD block is in *REMOTE* control mode, state changes cannot be initiated from the PWC90 console. The block output tracks the value of another function block in the process control configuration.

The current control mode is identified by a red dot in the current mode control prompt.

**One State Descriptor** The one state descriptor is text that describes a one state (logic one) output of the DD function block. This descriptor is the *ONE* state descriptor defined in the database for the tag.

**Output Indicator (Red Dot)** The output indicator (Red Dot) position identifies the requested logic state to be output by the DD block. For example, the output is a logic one when it is next to the one state descriptor.

**Override Indicator** The override indicator identifies an override condition. Normally, the device driver block determines the output status by comparing the feedback signals to an expected condition defined in its configuration. An *OVR* indication occurs when the DD block is set to override its reported output status. The override forces the status to zero (good).

**Zero State Descriptor** The zero state descriptor is text that describes a zero state (logic zero) output of the DD function block. This descriptor is the *ZERO* state descriptor defined in the database for the tag.

---

### ***DD CONTROL***

DD control allows manually changing the output of a device driver function block in a Multi-Function Processor module. The device driver block provides a digital signal to a process device.

The DD function block can develop its outputs based on control logic or an input from the PWC90 console. Or, it can be unconditionally set with interlock logic. The function block specifications determine which will occur. The operating modes also depend on this selection. The block can be set to allow automatic mode only, automatic and manual mode, or remote mode only.

---

### ***Changing the Output State***

The DD block output cannot be changed while the block is in *REMOTE* mode. Manual mode control may or may not be permitted while the block is in an override (*OVR*) condition. This depends on the device driver block specifications.

To change the device driver output:

1. Click on [M] to toggle to *MANUAL* mode.
2. Click on the desired state:

One state output.

- ***or*** -

Zero state output.

The *red dot* indicates the current selection and will move to reflect the change. The feedback indicator will update after feedback is received from the process.

---

### ***MULTI-STATE DEVICE DRIVER FACEPLATE***

The multi-state device driver (MSDD) faceplate represents a multi-state device driver function block in a Multi-Function Processor module. This function block has three separate output conditions to provide three state process device control. An MSDD tag is required to both monitor and change the output provided by the block from the PWC90 console.

Figure 4-14 details the information presented in a device driver faceplate.

The multi-state device driver block exception reports the current state, four feedback states, override status, mode, alarm status, and quality presented in the MSDD faceplate. The following information explains the attributes that relate to an MSDD tag and can be incorporated into any graphic or custom faceplate. Figure 4-14 shows the location of the attributes described.

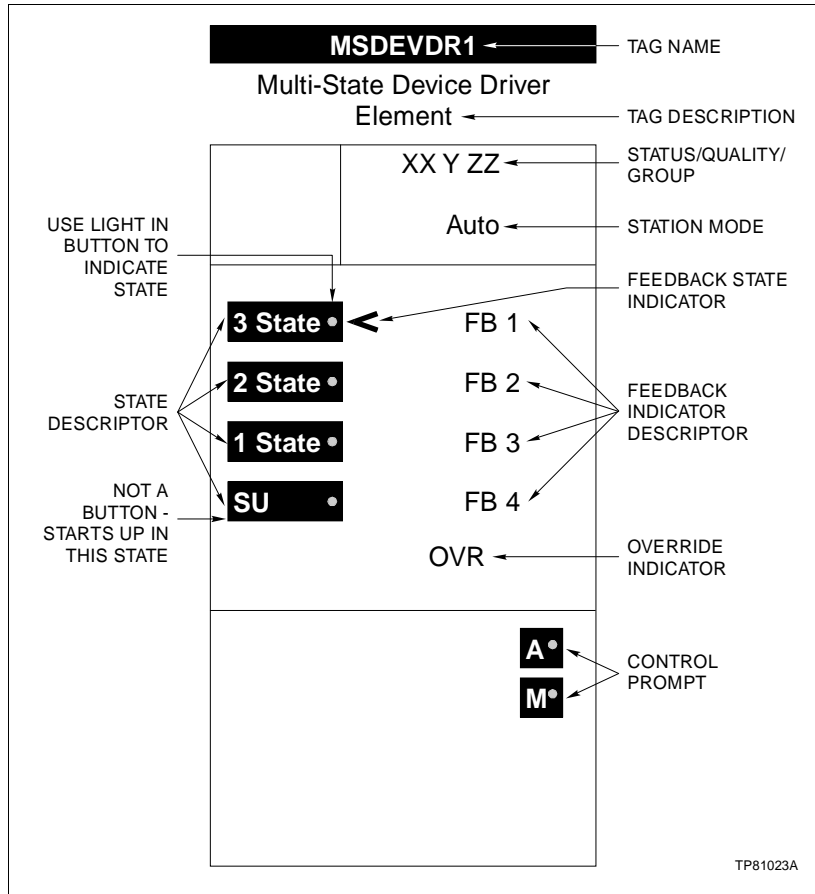

Figure 4-14. Multi-State Device Driver Faceplate

**Feedback Indicator Descriptors**

The feedback one, two, three, and four descriptors are text that describe the feedback signals input to the MSDD function block. The feedbacks will indicate either an on (logic one) or off (logic zero) state. The faceplate displays the *ZERO* and *ONE* descriptors defined in the database for feedback one through four.

The feedback indications provide a verification of the actual status of the field device. The MSDD block uses the feedback signals to determine if the output status is either good or bad.

**Feedback State Indicator**

The feedback indicator position identifies the current output based on feedback from the process. When a change is initiated, the indicator maintains its position until a specified time elapses before testing the feedback inputs. After the time elapses, the indicator positions on the appropriate state based on the feedback.

**Station Mode**

The mode shows the current operating condition of the block. A multi-state device driver block can be configured to operate in automatic mode only or automatic and manual mode. The MSDD function block specifications determine the acceptable operating modes.

While in *AUTO* mode, the control logic sets the output state of the multi-state device driver block. The block only provides an update to the display. *MANUAL* mode allows changing the output state from the PWC90 console.

- One State Descriptor** The one state descriptor is text that describes a one state (output mask one) output of the MSDD function block. This descriptor is the *ONE* state descriptor defined in the database for the tag.
  
- Output Indicator (Red Dot)** The output indicator (Red Dot) position identifies the requested output of the MSDD block. For example, the requested output is output mask three when next to the three state descriptor. Refer to ***MSDD CONTROL*** in this section for an explanation of output masks.
  
- Override Indicator** The override indicator identifies an override condition. Normally, the multi-state device driver block determines the output status by comparing the feedback signals to an expected condition defined in its configuration. An *OVR* indication occurs when the MSDD block is set to override its reported output status. The override forces the status to zero (good). The MSDD can be configured to default to a specific mode and output when in an override condition.
  
- Three State Descriptor** The three state descriptor is text that describes a three state (output mask three) output of the MSDD function block. This descriptor is the *THREE* state descriptor defined in the database for the tag.
  
- Two State Descriptor** The two state descriptor is text that describes a two state (output mask two) output of the MSDD function block. This descriptor is the *TWO* state descriptor defined in the database for the tag.
  
- Zero State Descriptor** The zero state descriptor is text that describes a zero state (default mask) output of the MSDD function block. This descriptor is the *ZERO* state descriptor defined in the database for the tag.

---

***MSDD CONTROL***

MSDD control allows manually changing the output of the multi-state device driver function block in a Multi-Function Processor module. The multi-state device driver block provides three state control for a process device.

The MSDD function block can develop its outputs based on control logic or an input from the PWC90 console. In *AUTO* mode, two digital inputs from the control configuration select a mask that drives the outputs. In *MANUAL* mode, output masks are selected by pressing certain keys on the PWC90 console.

The function block can be set to allow automatic mode only or both automatic and manual mode.

Four separate output masks defined in the MSDD configuration determine the control output signals that are sent to a process device. Each mask, defined as a three-bit code, specifies the state of each of three MSDD block outputs. A specific output mask is selected by two inputs to the block.

---

### ***Changing the Output State***

The MSDD block output cannot be changed while the block is in automatic (*AUTO*) mode. Manual mode control may or may not be permitted while the block is in an override (*OVR*) condition. This depends on the multi-state device driver block specifications.

To change the multi-state device driver output:

1. Click on [M] to toggle to *MANUAL* mode.
2. Click:

Three state outputs (output mask three).

Two state outputs (output mask two).

- **or** -

One state outputs (output mask one).

The *red dot* indicates the current selection and will move to reflect the change. The feedback indicator will update after feedback is received from the process.

The MSDD function block may be set up to prevent random output changes while in *MANUAL* mode. This prevents accidental upsets to the process. In this case, a sequence defined in the function block must be followed. The block identifies which output states can be selected based on the current output state.

---

### ***REMOTE MOTOR CONTROL BLOCK FACEPLATE***

The remote motor control block (RMCB) faceplate represents a remote motor control function block in a Multi-Function Processor module. This function block implements a start and stop logic sequence to direct the start up or shutdown of a process device. An RMCB tag is required to both monitor and change the output provided by the block from the PWC90 console.

Figure 4-15 details the information presented in a remote motor control block faceplate.

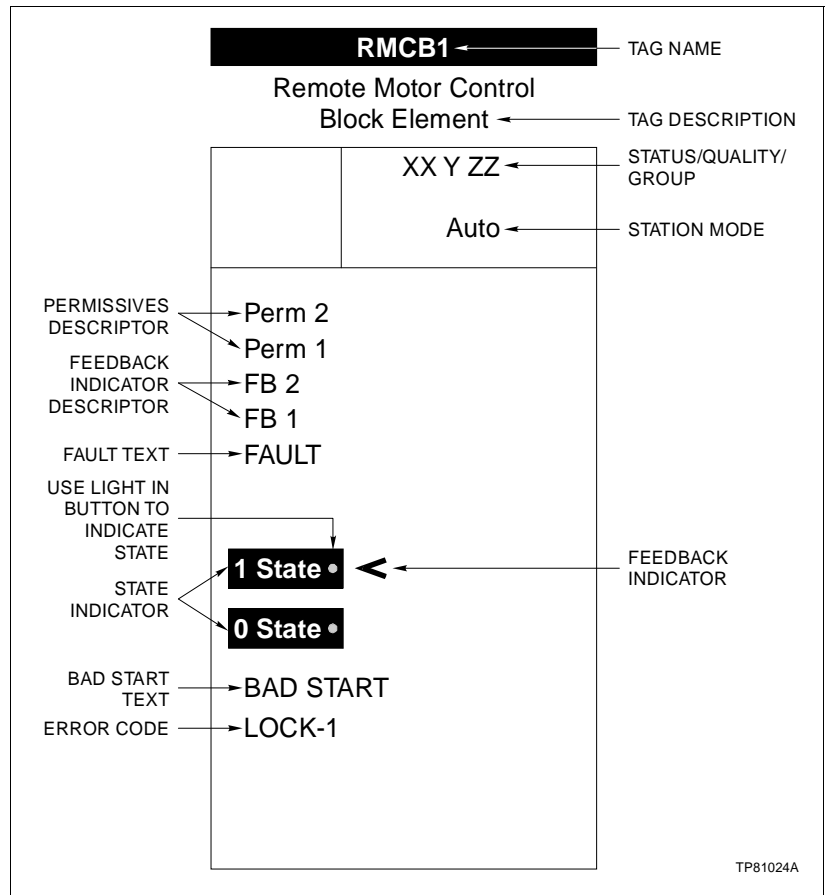

Figure 4-15. Remote Motor Control Block Faceplate

The remote motor control block exception reports the current state, two feedback states, two permissive states, fault status, error code, alarm status, and quality that display in the RMCB faceplate. The following information explains the attributes that relate to an RMCB tag and can be incorporated into any graphic or custom faceplate. Figure 4-15 shows the location of the attributes described.

**Bad Start Text**

The bad start text displays when the RMCB block has detected a bad start of the process device. The block monitors the feedback signals to determine a bad start.

**Error Code**

The error code text describes one of ten different error codes that can be reported by the RMCB block:

- 0 - No error.
- 1 - Stopped.
- 2 - Interlock one.
- 3 - Interlock two.
- 4 - Interlock three.

- 5 - Interlock four.
- 6 - Feedback one set to zero state.
- 7 - Feedback two set to zero state.
- 8 - Feedback one set to one state.
- 9 - Feedback two set to one state.

**NOTE:** The block sends an interlock error code when an interlock is set to a logic zero.

Only one error code displays at a time. A different text string is associated with each error code. A text set that defines a text string for each code must be created before the error text can be displayed. Refer to the discussion on remote motor control text in the **Personal Work Center 90 Configuration** instruction for further explanation.

**Fault Text** The fault text describes a fault condition being reported by the RMCB function block. A fault occurs when one of four interlock inputs to the block is set to off (or logic zero). All interlocks must be on (or logic one) to clear a fault.

**Feedback Indicator Descriptors** The feedback one and two descriptors are text that describe the feedback signals input to the RMCB function block. The feedbacks will indicate either an on (logic one) or off (logic zero) state. The faceplate displays the *ZERO* and *ONE* descriptors defined in the database for feedback one and two.

The feedback indications provide a verification of the actual status of the device. The RMCB block uses the feedback signals to determine if the output status is either good or alarm. The feedback signals are also used to determine whether to maintain a run output or to force the output to stop.

**Feedback Indicator** The feedback indicator position identifies the current output based on feedback from the process. When a change is initiated, the indicator maintains its position until a specified time elapses before testing the feedback inputs. After the time elapses, the indicator positions on the appropriate state. Table 4-7 shows the relationship between reported feedback state and feedback indication.

*Table 4-7. RMCB Feedback Signal to Feedback Indicator Relationship*

<b>FB1 State</b>	<b>FB2 State</b>	<b>One State Indication</b>	<b>Zero State Indication</b>
0	0	Blank	Hollow
0	1	Blank	Hollow
1	0	Blank	Hollow
1	1	Filled	Blank

**One State Descriptor** The one state descriptor is text that describes a one state output of the RMCB function block. A one state for the RMCB

	block sets a device to a running state. This descriptor is the <i>ONE</i> state descriptor defined in the database for the tag.
<b>Output Indicator (Red Dot)</b>	The output indicator (Red Dot) position identifies the currently requested output of the RMCB function block. When next to the one state descriptor, the requested output is run (logic one). The block is set to stop when positioned next to the zero state descriptor.
<b>Permissive Descriptor</b>	The permissive one and two descriptors are text that describe the permissive inputs to the function block. The faceplate displays the <i>ZERO</i> and <i>ONE</i> descriptors defined in the database for permissive one and permissive two. Both permissive inputs to the block must be in a permissive state (one state) to change the RMCB block to its one state (run).
<b>Zero State Descriptor</b>	The zero state descriptor is text that describes a zero state output of the RMCB function block. A zero state for the RMCB block sets a device to a stopped state. This descriptor is the <i>ZERO</i> state descriptor defined in the database for the tag.

---

**RMCB CONTROL**

RMCB control allows changing the output of a remote motor control function block in a Multi-Function Processor module. The remote control memory block provides a start and stop signal to a process device. The RMCB function block acts on one of two inputs to develop its output. The block accepts both a control configuration driven input and an input from the PWC90 console.

---

**Changing the Output State**

The RMCB block can only be changed from the PWC90 console (or control logic) if the permissive descriptors indicate a permissive state (one state). A fault must also be cleared before a change can occur. The fault is driven by the state of the interlock inputs.

To change remote motor control block output, press:

One state output (run).

Zero state output (stop).

The *red dot* indicates the current selection and will move to reflect the change. The feedback indicator will update after feedback is received from the process. Certain display faceplates, explained earlier, will update to indicate a bad start if an unsuccessful start up occurs.

**DATA ACQUISITION FUNCTIONS**

Process information is received in exception reports from function blocks configured in a Multi-Function Processor module. Data acquisition tags allow accessing specific function blocks within the control configuration to display analog values and digital state changes. An analog value can be a process variable such as flow rate, drum level, pressure, temperature, etc. A digital state can be an on or off, set or reset, and start or stop state for a process device. The tags also allow presenting alarm conditions and quality reported by the function blocks. The control ability for data acquisition tags allows changing process conditions from the PWC90 console by initiating changes to the Multi-Function Processor module.

**Data Acquisition Faceplates**

Dynamic faceplates for the different types of data acquisition tags can be either standard or user created. Standard data acquisition faceplates are provided. A data acquisition faceplate can be a fixed part of a display or it can be called as a pop-up faceplate. The same control actions can be performed from a fixed faceplate as can be performed from a pop-up faceplate. This assumes that the symbol file used for the fixed faceplate is also the same one used for the pop-up faceplate, or the pop-up faceplate, if different, has all the same capabilities as the fixed faceplate built in.

**Data Acquisition Tags**

Data acquisition tags provide access to data acquisition function blocks within a module. The access can be used to manually initiate changes and to monitor the results of both automatic and manual operations. Automatic refers to operation being performed under Multi-Function Processor module execution. Manual refers to those actions initiated after taking a function block out of automatic Multi-Function Processor control. Table 4-8 lists the data acquisition tags and the function codes (FC) they associate with.

*Table 4-8. Data Acquisition Tags*

<b>Tag</b>	<b>Function Code<sup>1</sup></b>
ANALOG	Analog exception report, FC 30
DADIG	Data acquisition digital, FC 211
DAANG	Data acquisition analog, FC 177
DIGITAL	Digital exception report, FC 45
TEXTSTR	User defined data export, FC 194

**NOTES:**

1. Information reported by the data acquisition function codes can be incorporated into any display. This information is not restricted to faceplate symbols only.
2. Does not implement the complete functionality of FC 177.

Refer to the **Function Code Application Manual** for a description of the data acquisition function codes and their specifications.

---

**Control Inhibit**

Control can be inhibited at the module level. This prevents control changes from being initiated from the PWC90 console. The inhibit status is checked when a control action is initiated. If inhibited, an invalid action message appears. Table 4-9 shows the inhibit indications that appear for data acquisition tags.

Table 4-9. Control Inhibit Indications (Data Acquisition Tags)

Tag	Inhibit Indication
DADIG	LOCKED
DAANG	LOCKED
TEXTSTR	USER TEXT LOCK

---

**Common Data Acquisition Faceplate Attributes**

The standard faceplate faceplates share some common attributes.

- Alarm status/quality/group.
- Red tag descriptor.
- Tag descriptor.
- Tag name.

These attributes can be incorporated into any graphic or custom faceplate.

**Status Alarm Suppression**

The DAANG, DADIG, and TEXTSTR tags present alarm suppression status in the status position of the alarm status/quality/group field. An !! appears when alarm suppression is enabled for the tag.

---

**Analog Faceplate Attributes**

This part of the section describes two basic data acquisition faceplate symbols used to present analog tag values. These faceplates do not have any control capabilities.

Figure 4-16 details the information presented in a standard analog faceplate and Figure 4-17 details the information in a standard analog annunciator.

An analog function block exception reports the current analog value, alarm status, and quality presented in these faceplates. The following information explains the attributes that relate to

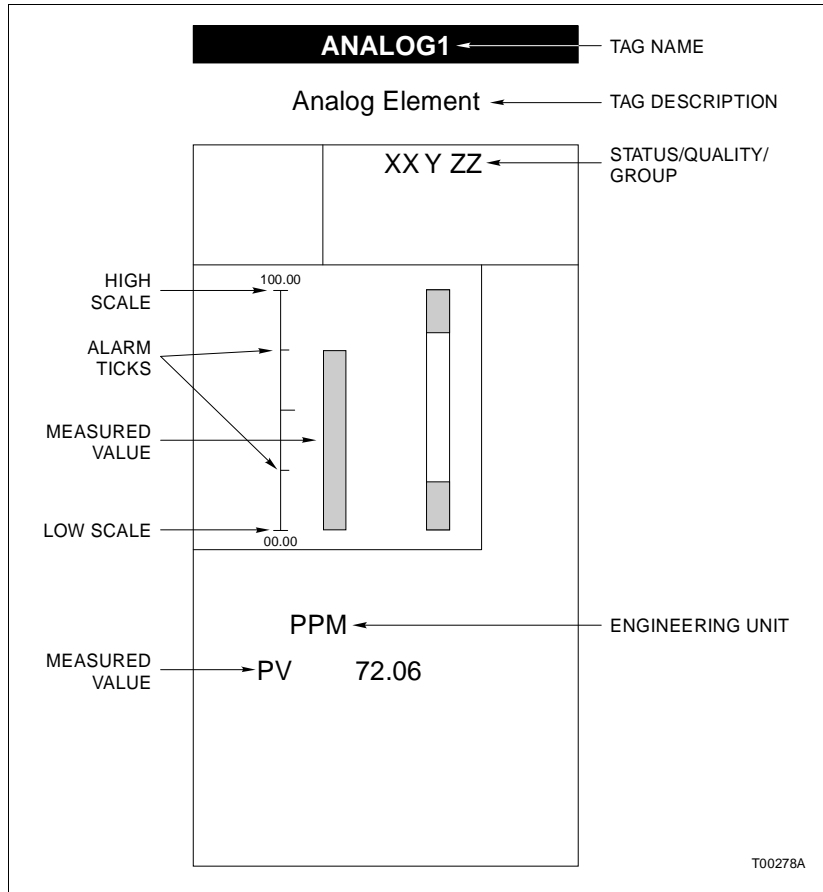

Figure 4-16. Analog Faceplate

an analog type of tag and can be incorporated into any graphic or custom faceplate. Figures 4-16 and 4-17 show the location of the attributes described.

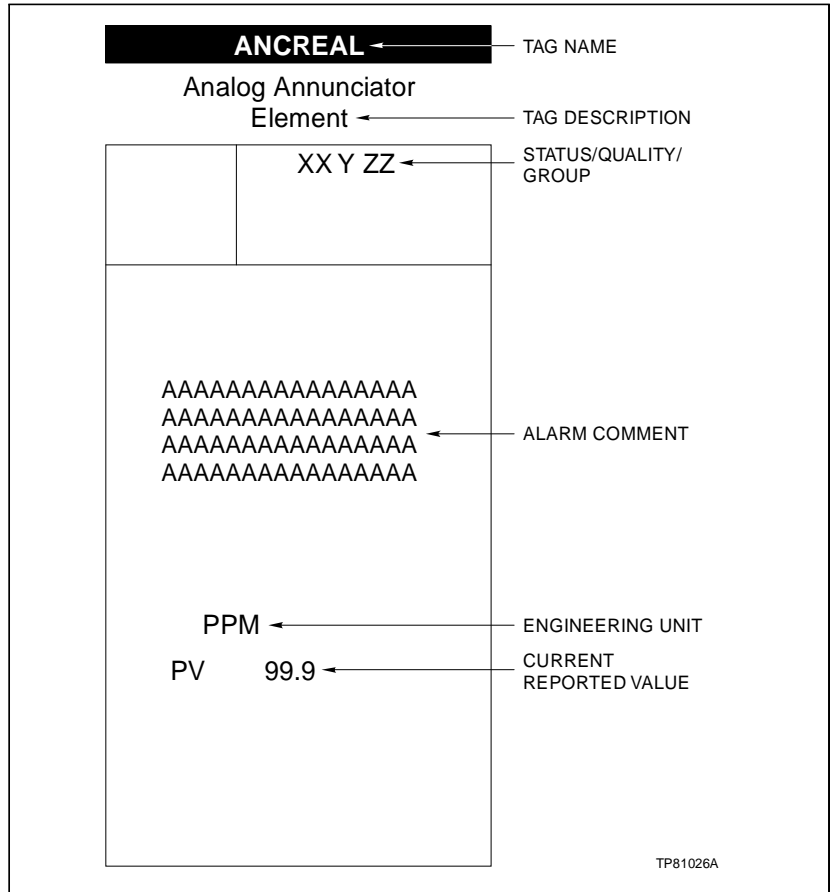

Figure 4-17. Analog Annunciator Faceplate

**Alarm Comment**

The alarm comment is text that describes an alarm condition. The comment can be up to 64 characters. The comment can describe, for example, the purpose of the alarm indication or operator actions required to correct the alarm. An alarm comment can be defined for each tag alarm condition.

**Current Reported Value**

The current analog value is the value being exception reported by the analog function block. This value is dynamic and changes as the variable being monitored changes.

**Engineering Unit Descriptor**

The engineering unit descriptor (EUD) shows the unit of measurement for the analog value. The analog function block reports an EUD index number to select the appropriate engineering unit descriptor.

**High and Low Scale Limits**

The high and low scale limits are the maximum and minimum value associated with the top line and baseline of the static scale respectively. The limits are derived from the zero and span configured in the analog function block for either the process variable or the set point depending on the station faceplate configuration.

**Alarm Bar** The alarm bar provides a scale reference to easily determine when the PV dynamic bar passes an alarm limit. These bar uses colored areas to indicate the position of the high and low alarm limit points.

**Measured Value (PV)** The measured value (PV) is the value of the process variable exception reported from the control faceplate.

**Digital Faceplate Attributes**

This part of the section describes two basic data acquisition faceplate symbols used to present digital states. These faceplates do not have any control capabilities.

Figure 4-18 details the information presented in a standard digital display faceplate. Figure 4-19 details the information presented in a digital annunciator.

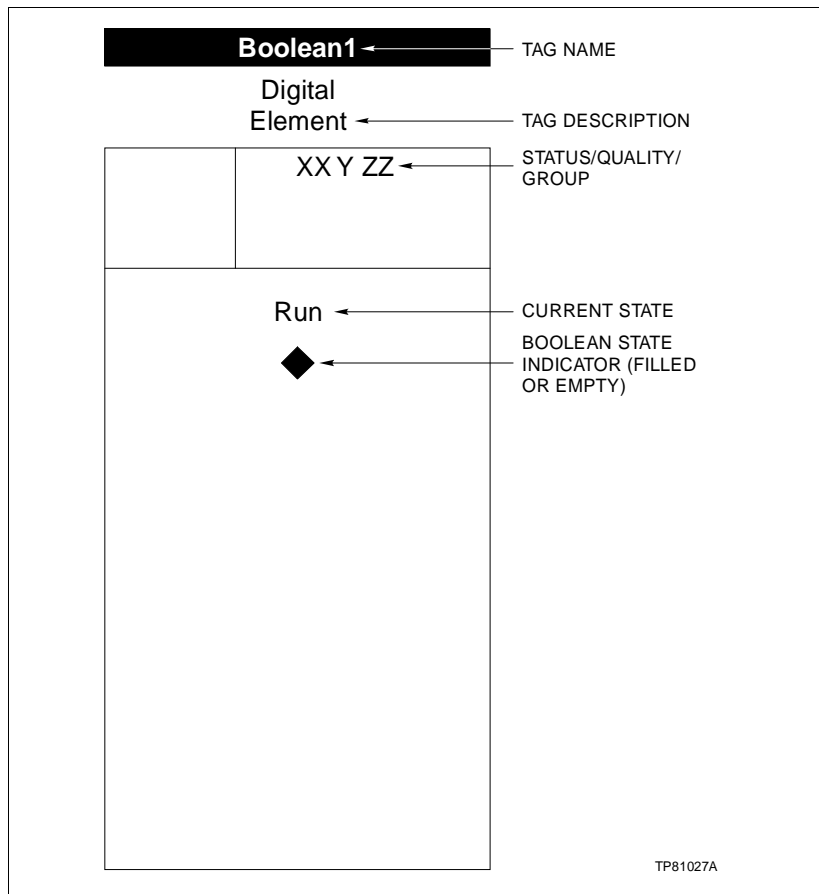

Figure 4-18. Digital Faceplate

A digital function block exception reports the current state, alarm status, and quality presented in these faceplates. The following information explains the attributes that relate to a digital type of tag and can be incorporated into any graphic or

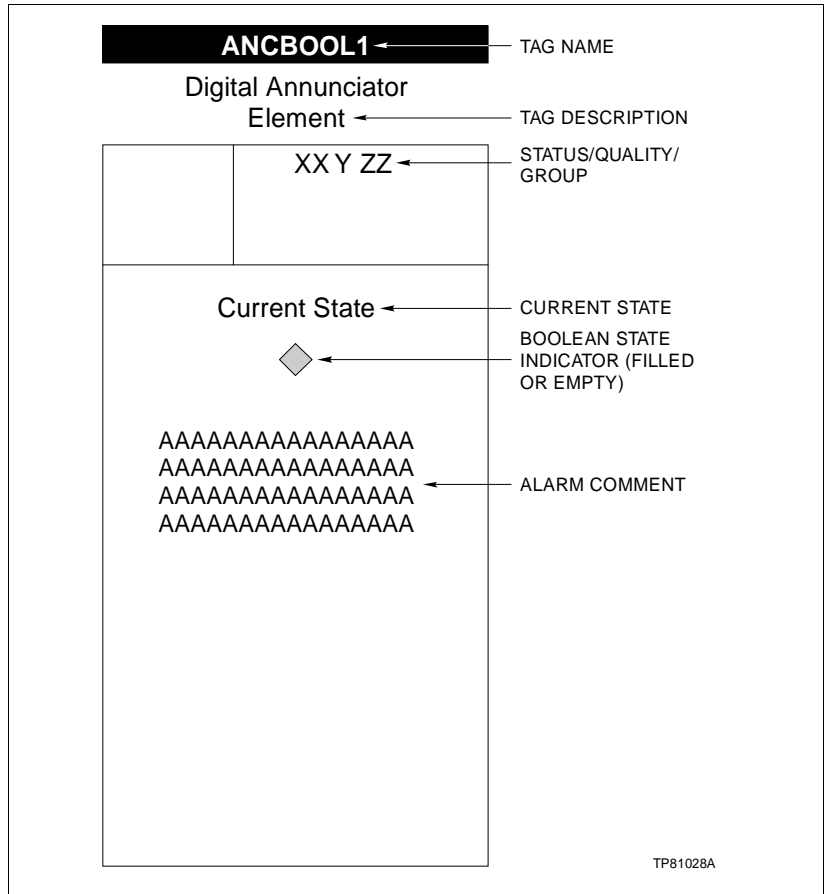

Figure 4-19. Digital Annunciator Faceplate

custom faceplate. Figures 4-18 and 4-19 show the location of the attributes described.

**Alarm Comment**

The alarm comment is text that describes an alarm condition. The comment can be up to 64 characters. The comment can describe, for example, the purpose of the alarm indication or operator actions required to correct the alarm. An alarm comment can be defined for each tag alarm condition.

An alarm for a digital type of tag is used to identify one of two possible states. The specific state that causes an alarm indication is determined by the function block configuration. A digital alarm may not actually be a problem condition, but instead an indication of a digital state transition.

**Current State**

The current state is text that describes the output state being exception reported by a digital function block. This state is dynamic and changes as the logic state being monitored changes. The descriptor that appears is either the *ONE* or *ZERO* state descriptor defined in the database.

**Data Acquisition Analog Faceplate**

A data acquisition analog function code (FC 177) is used to report an analog value. It provides multilevel, rate of change, and deviation alarming capabilities for an analog point. It also supports several time based alarming options with time based alarm filtering capabilities. The PWC90 console gives access to the function block to allow viewing the process variable being monitored by the block and its status. Also, it allows interaction with the block to change the input source and to enter a user inserted value if desired. The block stores the user inserted value in nonvolatile memory.

**DAANG FACEPLATE ATTRIBUTES**

The data acquisition analog (DAANG) faceplate represents a data acquisition analog function block in a Multi-Function Processor module. A DAANG tag is required to monitor and control the operation of this function block.

Figure 4-20 details the information presented in a data acquisition analog faceplate.

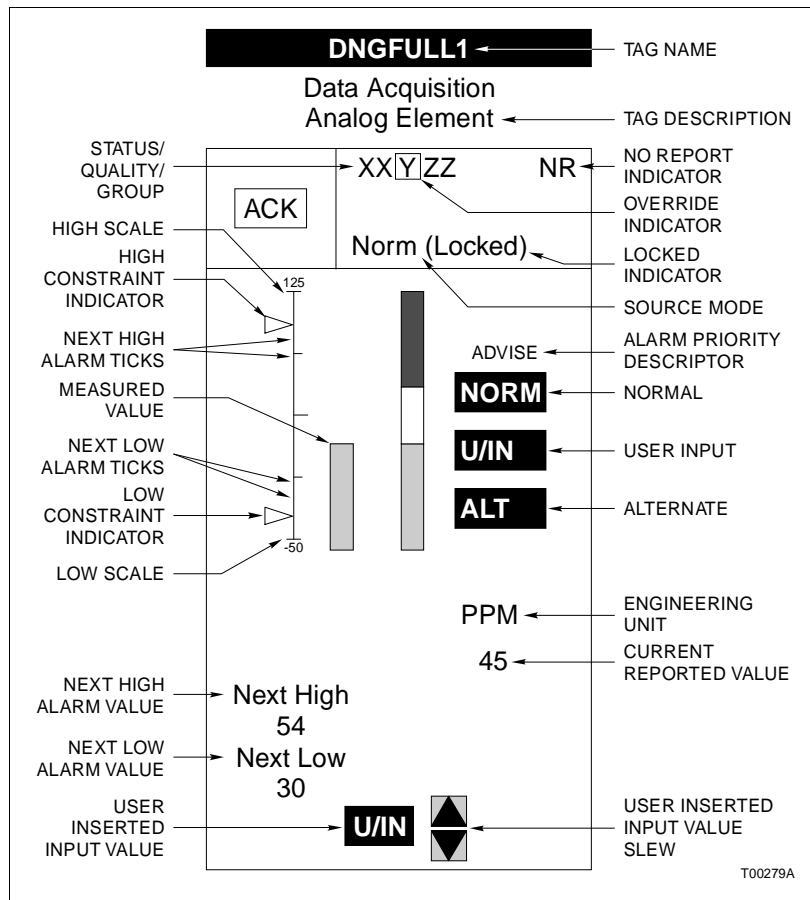

Figure 4-20. Data Acquisition Analog Faceplate

The data acquisition analog block exception reports the current analog value, input source mode, alarm status, and quality that display in a data acquisition analog faceplate. The following information explains the attributes that relate to a DAANG tag and can be incorporated into any graphic or custom faceplate. Figure 4-20 shows the location of the attributes described.

<b>Alarm Priority Descriptor</b>	The alarm priority descriptor is text that describes the priority of an alarm level or bad quality being reported by the function block. A priority level can be selected for each tag alarm condition.
<b>Current Reported Value</b>	<p>The current analog value is the value being exception reported by the data acquisition analog function block. This is the function block output. The output value depends on the input source selection and can be an actual process value, the alternate input value, or the user inserted value.</p> <p>During data acquisition analog function block configuration, constraint limits can be established for the normal, user inserted, and alternate values. The maximum and minimum value displayed and reported by the block will always be within the constraint limits even if the variable being monitored exceeds the constrained level. The value is always the true value when within the constrained limits.</p>
<b>Measured Value</b>	The measured value shows the value as an expanding bar.
<b>Engineering Unit Descriptor</b>	The engineering unit descriptor (EUD) shows the unit of measurement for the analog value. The data acquisition analog function block reports an EUD index number to select the appropriate engineering unit descriptor.
<b>High Scale</b>	The high display reference is the highest value for the bar graph and constraint limits. The dynamic bar representation of the value and the constraint limit indicators are displayed proportionally between the high display reference value and the low display reference value.
<b>Low Scale</b>	The low display reference is the lowest value for the bar graph and constraint limits. The dynamic bar representation of the value and the constraint limit indicators are displayed proportionally between the high display reference value and the low display reference value.
<b>Next High Alarm Bar</b>	The next high alarm bar provides a scale reference to easily determine when the PV dynamic bar passes an alarm limit. These bar uses colored areas to indicate the position of the high and low alarm limit points. Refer to Table 4-10 to determine the criteria for this field.

Table 4-10. DAANG Faceplate Next High and Next Low Alarm Limit Criteria

Current Alarm State	Next High Value <sup>1</sup>	Next Low Value <sup>1</sup>
blank (no alarm) N	H H	L L
3H 2H H L 2L 3L	> 3H 2H L 2L 3L	3H 2H H 2L 3L >
V3H V2H VH VL V2L V3L	> V3H V2H VL V2L V3L	V3H V2H VH V2L V3L >
HD LD HR LR !!	blank blank blank blank blank	blank blank blank blank blank

**NOTE:**

1. Value that will appear in the next alarm level fields. For example, if the current value is 45.00, the next high alarm field might be 50.00 (3H) and the next low 40.00 (2H). This indicates that the current value is between the 3H and 2H alarm values. If the current value drops below the 2H value, the 2H and H alarm values will appear.

**Next Low Alarm Bar** The next low alarm bar provides a scale reference to easily determine when the PV dynamic bar passes an alarm limit. These bars use colored areas to indicate the position of the high and low alarm limit points. Refer to Table 4-10 to determine the criteria for this field.

**No Report Indicator** The no report indicator shows whether the function block is in a report or a no report condition. The field appears as *NR* for a no report condition or blank for a report condition. Refer to **OPERATING PARAMETERS** in Section 13 for the procedures to enable or disable reporting.

**Override Indicator** The quality override indicator appears to identify that the block is in an override condition. The block allows an external source to override the quality status of the reported value. A box symbol around the quality field in the alarm status indicator identifies an override condition.

**Source Mode Descriptor** The source mode descriptor is text that describes the input source currently selected. The Multi-Function Processor module reports the current mode of the block. The descriptor also identifies whether the block is locked or not locked in a certain mode. The descriptors are shown in Table 4-11.

Table 4-11. Locked and Unlocked Indicators (DAANG)

Source Locked	Source Unlocked
NORM (Locked)	NORM
U/IN (Locked)	U/IN
ALT (Locked)	ALT

---

**DAANG CONTROL**

DAANG control allows changing the input source selection for a data acquisition analog function block and entering a user inserted value. Refer to **OPERATING PARAMETERS** in Section 13 for the procedures to change the alarm reporting and exception reporting status of a DAANG block.

**NOTE:** When the DAANG block is in a no report condition, any mode change causes the block to output a single exception report.

---

**Selecting the Source Mode**

The input source for the DAANG block can only be changed from the PWC90 console if the block is not in a locked state. An *(L)* appearing next to the source mode descriptor identifies a locked condition.

To select the source mode click on the button of the desired mode. The selections are:

*N* - for normal mode.

*U/IN* - for user inserted mode.

*A* - for alternate mode.

A red dot will appear on the button of the selected mode.

---

**Changing the User Inserted Value**

To change the user inserted value being stored in nonvolatile memory of a Multi-Function Processor module:

1. Click on U/IN in the lower left corner of the faceplate.
2. Enter the value in the popup window that appears.
3. Or use the slew buttons to raise or lower the value.

---

**Data Acquisition Digital Faceplate**

A data acquisition digital function code (FC 211) is used to report a digital state. It provides enhanced alarming capabilities for a digital point. The PWC90 console gives access to the

function block to allow viewing the device state being monitored by the block and its status. Also, it allows interacting with the block to change the input source and to enter a user inserted value if desired. The block stores the user inserted value in nonvolatile memory.

**DADIG FACEPLATE ATTRIBUTES**

The data acquisition digital (DADIG) faceplate represents a data acquisition digital function block in a Multi-Function Processor module. A DADIG tag is required to monitor and control the operation of this function block.

Figure 4-21 details the information presented in a data acquisition digital faceplate.

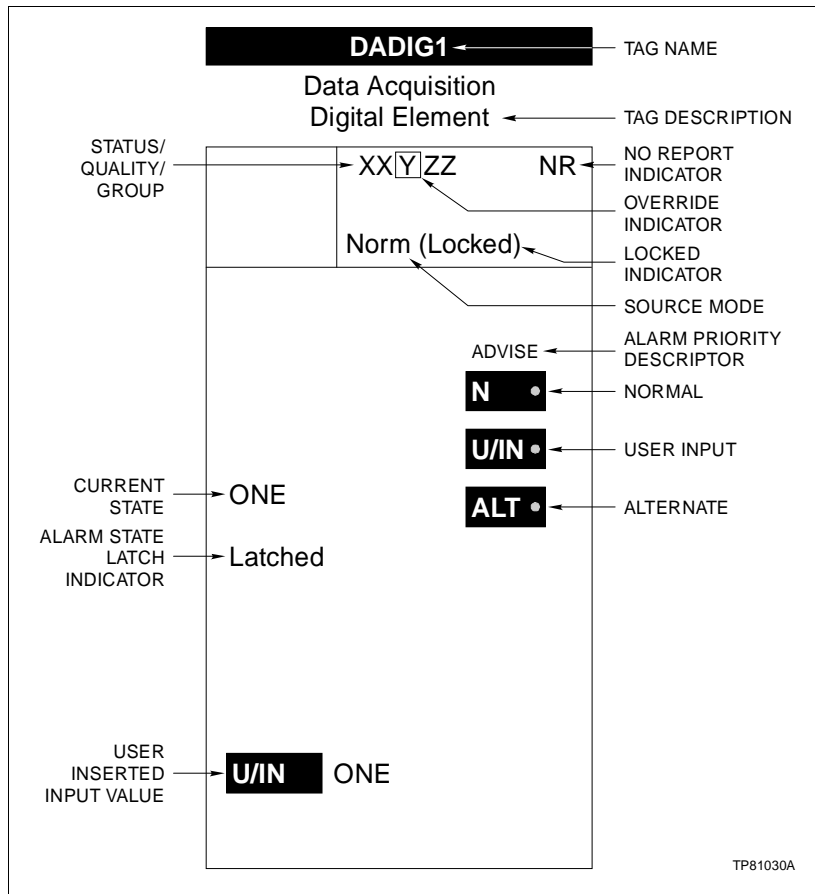

Figure 4-21. Data Acquisition Digital Faceplate

The data acquisition digital block exception reports the current state, input source mode, alarm status, and quality that displays in a data acquisition digital faceplate. The following information explains the attributes that relate to a DADIG tag and can be incorporated into any graphic or custom faceplate. Figure 4-21 shows the location of the attributes described.

<b>Alarm Priority Descriptor</b>	The alarm priority descriptor is text that describes the priority of an alarm level or bad quality being reported by the function block. A priority level can be selected for each tag alarm condition.
<b>Alarm State Latch Indicator</b>	The alarm state latch indicator appears to indicate that the function block has its alarm state latch feature enabled. The field appears as <i>LATCHED</i> when enabled or blank when not. Refer to <b>OPERATING PARAMETERS</b> in Section 13 for the procedures to reset the alarm state latch if enabled.
<b>Alarm Status</b>	<p>During data acquisition digital function block configuration, either an unconditioned input or a conditioned input can be chosen to drive alarming. Also, one of four modes of alarming can be chosen. Refer to the <b>Function Code Application Manual</b> to determine the affects of these features on the reported alarm status.</p> <p>The block also supports automatic alarm suppression and re alarming.</p>
<b>Current State</b>	<p>The current state is text that describes the output being reported by the data acquisition digital function block. The descriptor that appears depends on the input source selection and can be an actual process state, the alternate input state, or the user inserted state. The descriptor that appears is either the <i>ONE</i> or <i>ZERO</i> state descriptor defined in the database.</p> <p>During data acquisition digital function block configuration, input conditioning can be chosen to develop the function block output. Refer to the <b>Function Code Application Manual</b> to determine the affects of this conditioning on the reported output.</p>
<b>No Report Indicator</b>	The no report indicator shows whether the function block is in a report or a no report condition. The field appears as <i>NR</i> for a no report condition or blank for a report condition. Refer to <b>OPERATING PARAMETERS</b> in Section 13 for the procedures to enable or disable reporting.
<b>Quality Override Indicator</b>	The quality override indicator appears to identify that the block is in an override condition. The block allows an external source to override the quality status of the reported value. A box symbol around the quality field in the alarm status/quality/group identifies an override condition.
<b>Source Mode Descriptor</b>	The source mode descriptor is text that describes the input source currently selected. The Multi-Function Processor module reports the mode of the block. The descriptor also identifies whether the block is locked or not locked in a certain mode. The descriptors are shown in Table 4-12.

Table 4-12. Locked and Unlocked Indicators (DADIG)

Source Locked	Source Unlocked
NORM (Locked)	NORM
U/IN (Locked)	U/IN
ALT (Locked)	ALT

---

**DADIG CONTROL**

DADIG control allows changing the input source selection for a data acquisition digital function block and entering a user inserted value. Refer to **OPERATING PARAMETERS** in Section 13 for the procedures to change the alarm reporting and exception reporting status and to reset the alarm state latch for a DADIG block.

**NOTE:** When the DADIG block is in a no report condition, any mode change causes the block to output a single exception report.

---

**Selecting the Source Mode**

The input source for the DADIG block can only be changed from the PWC90 console if the block is not in a locked condition. *Locked* next to the source mode descriptor identifies a locked condition.

---

**Changing the User Inserted State**

To change the user inserted state being stored in nonvolatile memory of a Multi-Function Processor module, press the following keys:

- One state output.
- Zero state output.

---

**Text String Faceplate**

The text string faceplate allows interacting with an application program running in a Multi-Function Processor module. A user defined data export function code (FC 194) in a Multi-Function Processor module provides the interface between the PWC90 console and the program. A data export function block can also be driven by another function block rather than directly by an application program.

The text string functionality provides a means to prompt or question an operator and have the operator respond to the prompt or question in some manner. The response may be to make some type of selection, to acknowledge an event, or to provide an answer to a question. It can also be used to simply

monitor and verify the progress of a process routine through descriptive text.

The capabilities provided by the text string function are not limited to the uses previously described. A C language program or batch program executing in the Multi-Function Processor module determines the text string operations that can be performed.

**TEXTSTR FACEPLATE ATTRIBUTES**

The text string (TEXTSTR) faceplate gives access to a user defined data export function block in a Multi-Function Processor module. A TEXTSTR tag is required to interact with this function block.

Figure 4-22 details the information presented in a text string faceplate.

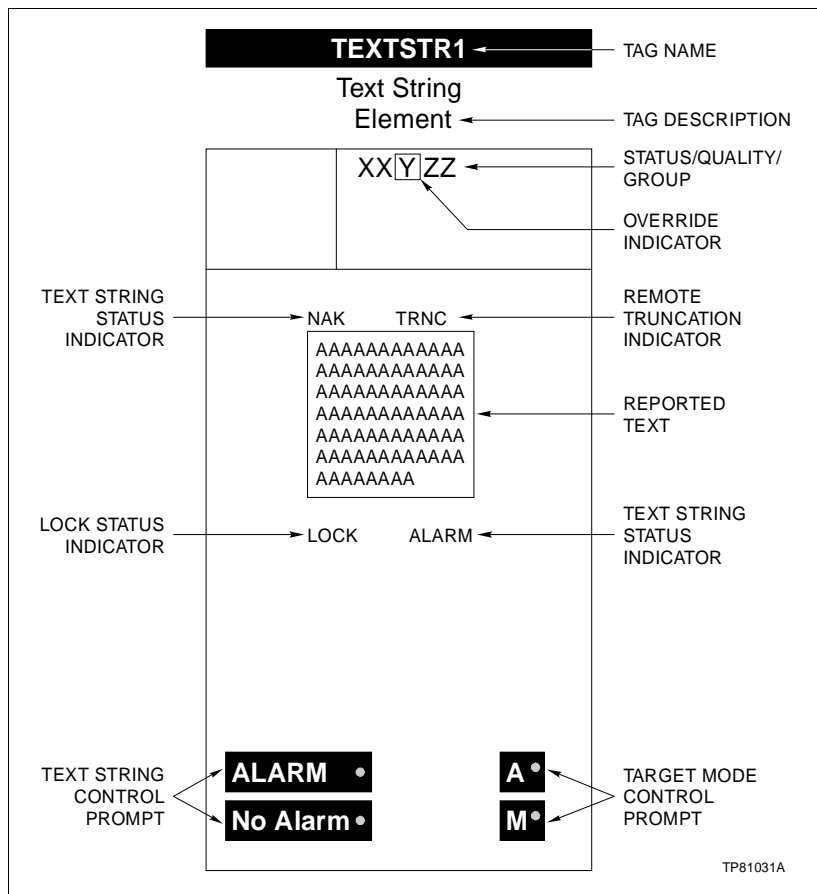

Figure 4-22. Text String Faceplate

The user defined data export block exception reports the text string message, alarm status, and quality that displays in a text string faceplate. The following information explains the

attributes that relate to a TEXTSTR tag and can be incorporated into any graphic or custom faceplate. Figure 4-22 shows the location of the attributes described.

<b>Lock Status Indicator</b>	The lock status indicator appears when the function block is in a locked condition. When locked, the block does not accept an input from the PWC90 console. The default descriptor is <i>USER TEXT LOCK</i> .
<b>Target Mode Control Prompt</b>	The mode shows the current block operating condition. The block operates in either automatic ( <i>A</i> ) or manual ( <i>M</i> ) mode. The operating mode determines how the block output is derived. A red dot shows the current operating mode.
<b>Override Indicator</b>	The quality override indicator appears when the block is in an override condition. The block allows an external source to override its quality status. A box symbol around the quality field in the alarm status/quality/group identifies an override condition.
<b>Reported Text</b>	The reported text string is the text string being exception reported by the user defined data export function block (FC 194). This string contains up to 80 characters.
<b>Text String Status Indicator</b>	<p>The text string status indicator has two functions. The first is to indicate that there is an alarm associated with the text string being entered if this association is considered necessary. For this purpose, the indication is either ( ) for no alarm or (A) for alarm.</p> <p>The second function is to indicate that following an operator entered response to a prompt or question the initial prompt or question was received again by the PWC90 console. This occurs when the application program has rejected the response for some reason and has sent the same text string to the PWC90 console for another response. If this happens, it is possible for a prompt to appear again with the same text string without first seeing the entered reply confirmed with a new text string. A <i>NAK</i> (negative acknowledgment) indication is given to identify that the text string is the same prompt or question that had been previously responded to, but was regenerated. This requires, however, that the program be specifically written to prompt again after rejecting an input.</p> <p>The block also supports re-alarms. Refer to the <b>Function Code Application</b> instruction to determine the affects of this feature on the reported alarm status.</p>
<b>Remote Truncation Indicator</b>	The truncation indicator appears when the reported text string has been remotely truncated. Remote truncation is performed by a Multi-Function Processor module or the communications interface unit of the PWC90 console. <i>TRNC</i> appears if remote truncation has occurred.

To identify where remote truncation is occurring and to help identify a truncation error, the operating parameters page for a TEXTSTR tag provides text string length information. A PWC90 string length field displays the length defined in the tag database for the TEXTSTR tag. A module string length field identifies the length set in the function block. A *received String Length* field shows the actual length of the text string received in the last exception report for the tag. Refer to **TEXTSTR CONTROL** in this section for the procedures to call the operating parameters page.

---

### TEXTSTR CONTROL

TEXTSTR control allows the operator to respond to a prompt or question introduced by a user written application program. Control also allows changing the operating mode of the user defined data export function block to establish the output of the block. Refer to **OPERATING PARAMETERS** in Section 13 for the procedures to change the alarm reporting status for a user defined data export function block (TEXTSTR tag).

---

#### Changing the Mode

The mode can be changed to determine the output of the user defined data export function block. Click on (A) or (M) mode control to select between manual and automatic mode. The block operates in several ways depending on its input source (application program or function block) and mode (automatic or manual).

#### Application Driven

When an application program drives the user defined data export block, it always controls the block output while in automatic (A) mode. It also always sets the alarm status and quality for the block.

When the block is placed in *AUTO* mode, the application can read any input from the PWC90 console. Depending on how the program is written, it may or may not update the block output based on this input. The block does not exception report a new text string to update the display unless the application itself updates the block output or changes either the alarm status or quality status of the block. The application does not echo the text string back to the PWC90 console unless the program is explicitly written to do so. An echo feature like this, which can be used to confirm that the block received the entered text, must be built into the program to occur. The block does, however, generate a new exception report automatically even if the application does not change an output when the maximum time for exception reporting expires.

When the block is in *MANUAL* mode, the application can still read any input from the PWC90 console. In this case, the output may either be a new text string generated by the applica-

tion, or the output may be an echo of the operator entered text string. When the block receives an input from the PWC90 console, it immediately places the input into its output buffer. This text string is output in the next exception report unless the application overwrites it before the block generates a new exception report.

**Block Driven** The user defined data export block in *AUTO* mode operates basically the same when driven by another function block as it does when driven by an application program. The difference is that the function block driving the user defined data export block sets the alarm status and quality rather than the application program.

When the block is in *MANUAL* mode, only the PWC90 console controls the block output. The block exception reports any text strings entered from the PWC90 console. The text string is echoed back as the reported text string.

Table 4-13 summarizes the user defined data export function block operation based on the input source, mode, and lock status.

Table 4-13. *TEXTSTR* Faceplate Operating Conditions

Input Source	Mode	Lock Status	Operation
Application	AUTO	Locked	The application controls the user defined data export block output not allowing any input from the PWC90 console.
	AUTO	Unlocked	The application controls the user defined data export block output allowing input from the PWC90 console. The application may or may not update the block output based on the input from the PWC90 console. It depends on how the program is written.
	MANUAL	Unlocked	Both the application and PWC90 console control the user defined data export block output. A text string received from the PWC90 console can be read by the application. The text string received from the PWC90 console becomes the block output unless the program updates the output with a new text string.
Function block	AUTO	Locked	Another function block controls the user defined data export block output not allowing any input from the PWC90 console.
	MANUAL	Unlocked	The PWC90 console controls the user defined data export block output. A text string received from the PWC90 console becomes the block output.

---

***Inputting a Text String***

The user defined data export function block only accepts input from the PWC90 console if the block is not in a locked condition. A *USER TEXT LOCK* indication identifies a locked condi-

tion. If any control is attempted while the block is locked, the following message appears:

*Control Invalid While in String Interlock.*

To enter a text string in response to a prompt or question:

1. The field is shaded to indicate that it is active.
2. Key in a the desired text. The maximum number of characters that can be entered is 80; however, the text length field defined in the database for the TEXTSTR tag the faceplate references determines the maximum number of characters displayed and accepted by the faceplate.
3. If desired, set the alarm state. Refer to **Setting the Alarm State** in this section for the procedures.

When the module sends an exception report to the PWC90 console containing a text string, the exception report also contains a sequence number associated with the text. The module uses the sequence number to insure that the response received from the PWC90 console corresponds to the text that was sent. The user defined data export block increments the sequence number each time the application program updates the block output with a new text string.

The message that is sent to the module in response to a prompt or question also contains the sequence number of the message to which the operator is responding. If the module detects a mismatch between its current sequence number and the received sequence number, it ignores the response. This insures the integrity between the prompt and the answer.

For example, a response to a question is currently being typed in and the display is updated with a new question before the response being typed is finished. This causes a mismatch between the current question, which is the newly generated one, and the response when it is finished being typed and **Enter** is pressed. To identify the mismatch, the following message appears:

*Response Is Invalid For Current Prompt.*

---

### **Setting the Alarm State**

The ability to indicate that there is an alarm associated with a response is provided. This is indicated as either alarm (A) or no alarm ( ). The default is no alarm. Refer to **TEXTSTR FACEPLATE ATTRIBUTES** in this section for an explanation of alarm state indications.

To indicate the alarm state for a text string, Click on:

Alarm.

No alarm.

---

## **PWC90 FACEPLATES**

The following faceplates are specific to the PWC90 console. The analog and digital export control faceplates allow the PWC90 console to place digital or analog exception reports on the INFI-NET. The module status and INFI 90 OPEN scanner faceplates allow the PWC90 console to check the status of modules in the INFI 90 OPEN system and to check the status of INFI 90 OPEN servers in the PWC90 network.

---

### **Analog Export**

Analog export tags exist only within the PWC90 console. Whenever the operator or a PWC90 application (like @aGlance) changes the value of an analog export tag, the PWC90 console will generate an exception report for that tag. This exception report can be received by other INFI 90 OPEN consoles and by process module blockware.

The faceplate (ANGRPRT1) has a *TARGET* button plus ramp up and ramp down buttons to change the tag's process value (Figure 4-23).

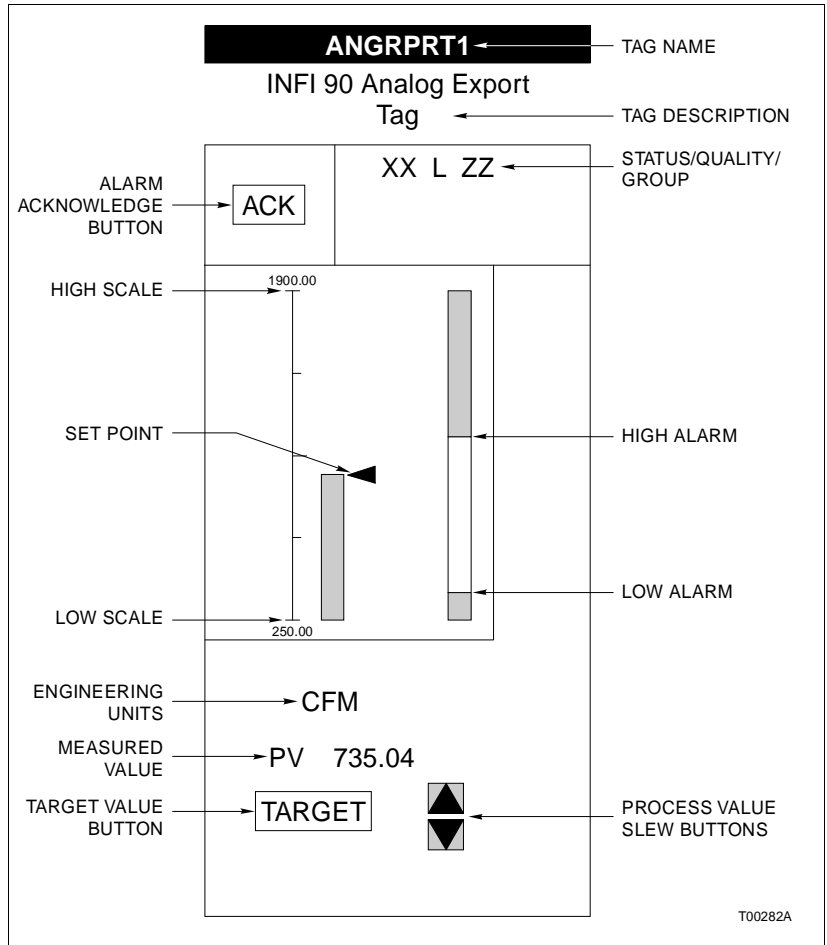

Figure 4-23. Analog Export Faceplate

**Engineering Unit Descriptor**

The engineering unit descriptor (EUD) shows the unit of measurement for the analog value. The data acquisition analog function block reports an EUD index number to select the appropriate engineering unit descriptor.

**Target Value**

The target button opens a value entry window. Entering a new value in the window changes the process value of the tag. This value can also be changed by using the slew buttons on the faceplate.

**Digital Export**

Digital export tags exist only within the PWC90 console. Whenever the operator or a PWC90 application (like @aGlance) changes the value of an digital export tag, the PWC90 console will generate an exception report for that tag. This exception report can be received by other INFI 90 OPEN consoles and by process module blockware.

The faceplate (DIGRPRT1) has a toggle to change the state of the tag's digital output (Figure 4-24).

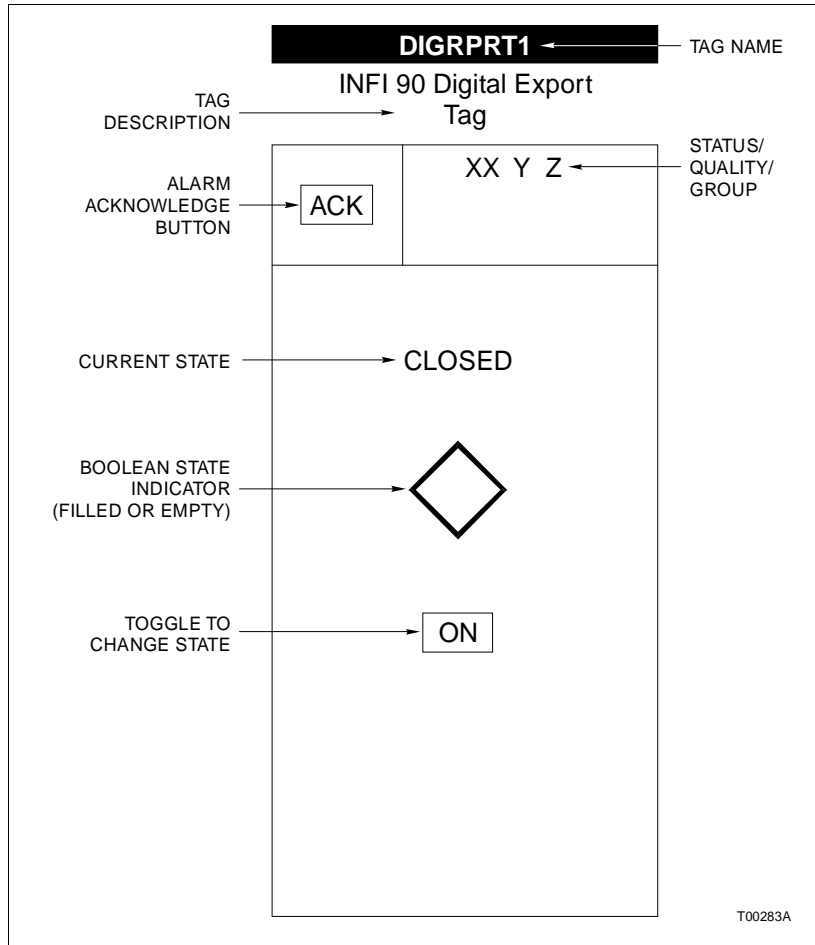

Figure 4-24. Digital Export Faceplate

**Current State** The current state is text that describes the output state being exception reported by a digital function block. This state is dynamic and changes as the logic state being monitored changes. The descriptor that appears is either the *ONE* or *ZERO* state descriptor defined in the database.

---

**Module Status**

Module status tags can be configured for every process module, process node, gateway, bridge, and computer interface in an INFI 90 OPEN system.

The faceplate (MODULE1) shows the INFI 90 OPEN address, the type of module or node, and the operating mode (*Configure*, *Error*, or *Execute*) for the tag (Figure 4-25).

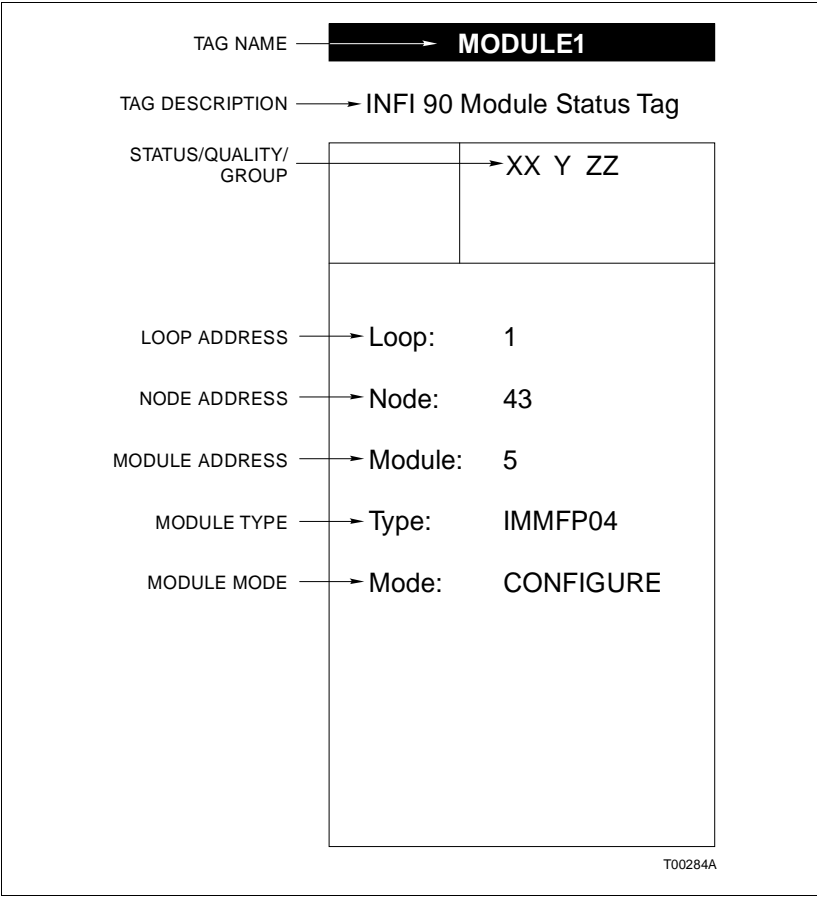

Figure 4-25. Module Status Faceplate

**INFI 90 OPEN Scanner Tag**

One INFI 90 OPEN scanner tag is assigned to every INFI 90 OPEN server. The faceplate (SERVER1) shows the INFI 90 OPEN address of the server's INFI 90 OPEN computer interface and indicates whether the server is on-line or off-line (Figure 4-26).

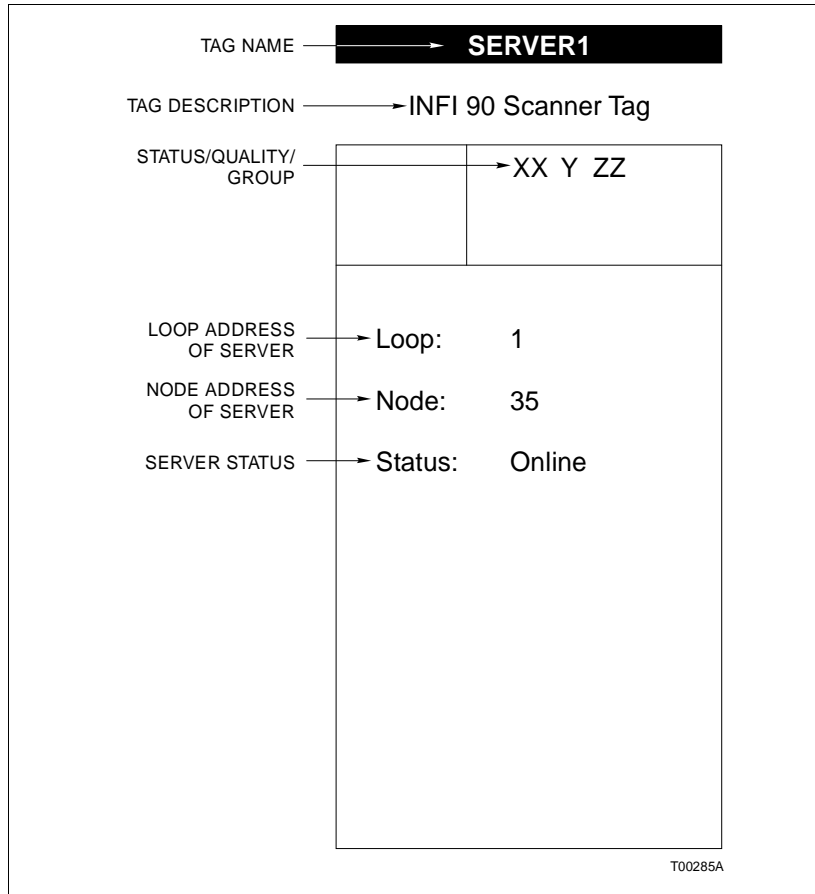

Figure 4-26. INFI 90 OPEN Scanner Faceplate

**POINT DISPLAY**

The point display provides detailed information for a tag in the global database, including information not shown on the group display. In addition, the parameters of a tag may be changed from the point display.

**Accessing the Point Display**

A point display can be accessed by one of several methods:

1. From a group display, click on the tagname pushbutton of the desired tag (Figure 4-8).
2. From the *Group Info* window of a summary display (Figure 4-5), click on the tagname pushbutton of the desired tag.
3. From the alarm review display, click on the pushbutton labeled *P* on the line containing the desired tag.
4. From the operator window *Select* menu, click on the *Point* item. The *Enter Tagname* pop-up window will appear (Figure

4-27). Type the tagname of the point (using the keyboard; to access a video version of the keyboard, click on the up arrow pushbutton; the video keyboard (Figure 4-28) will be displayed. Press **Enter** or click on **OK** to complete the operation.

5. From the keyboard, press **F4**. The *Enter Tagname* pop-up window will appear (Figure 4-27). Enter the tagname as described in item four above.

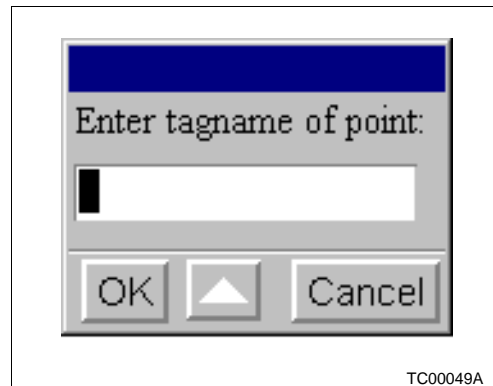

Figure 4-27. Enter Tagname Pop-Up Window

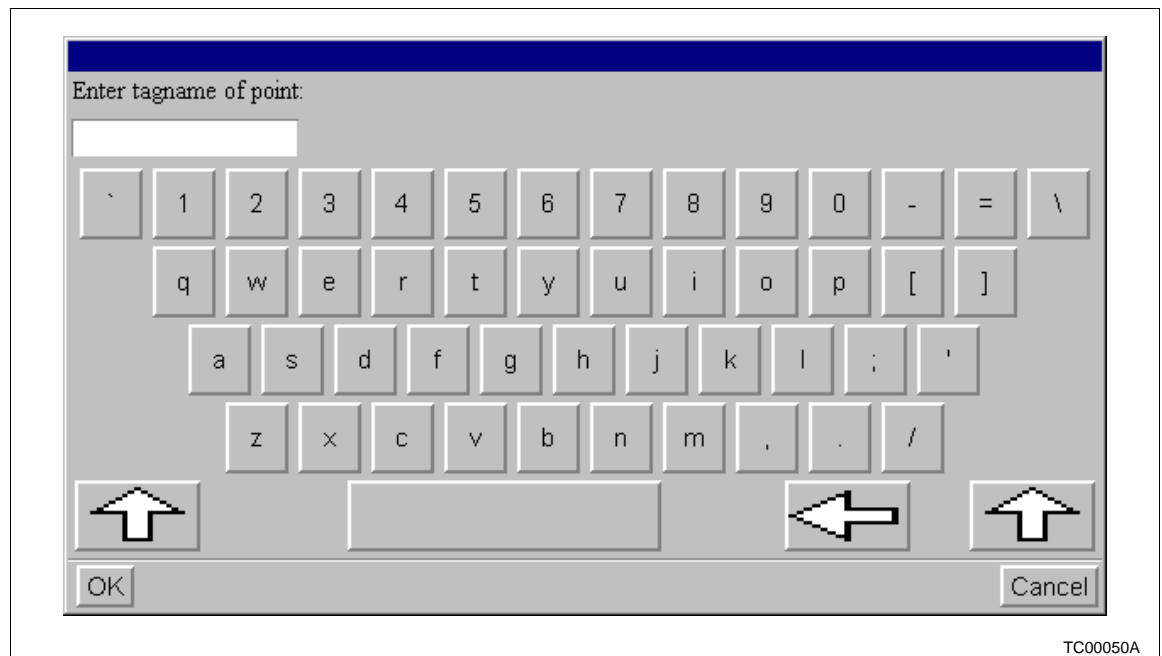

Figure 4-28. Enter Tagname Window

If a point display is accessed from a group (i.e., by method one or two), the point display for the next tag in the group can be accessed by using **Pg Dn** or the *Page Down* menu item. Similarly, the previous point in the group can be viewed using **Pg Up** or menu item. Wrap occurs between the first and last points.

**Point Display**

The appearance of a tag display varies according to the module type, the point display for every tag type will contain the following components, as shown in the point display for an ANALOG module (Figure 4-29).

**NOTE:** Operation of the ZOOM item on the group display menu bar is identical to that of the ZOOM item found on graphic displays; refer to *Zoom/Pan Window* in Section 7 for further information.

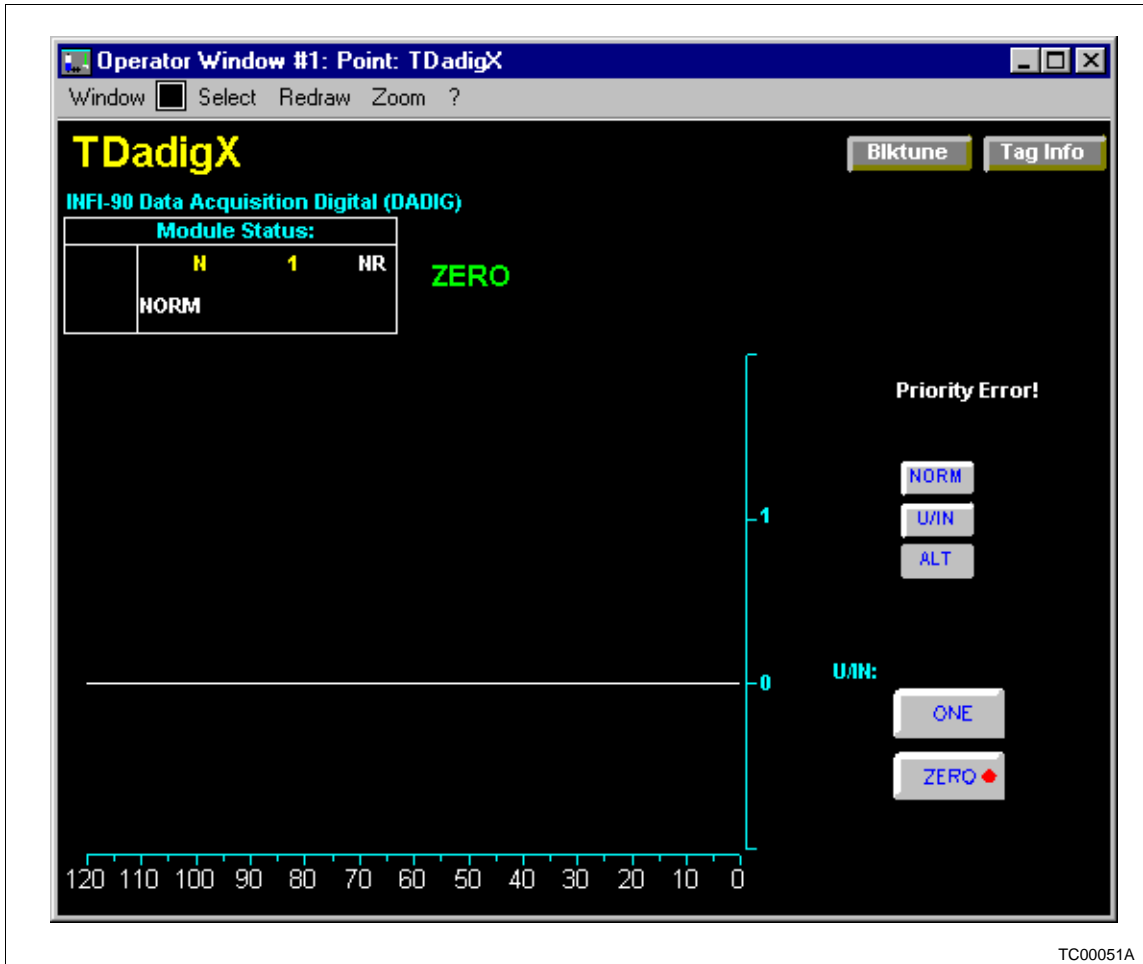

Figure 4-29. ANALOG Module Point Display

**TAGNAME**

The point tagname appears in the upper left corner of the point display. The full tagname (up to 16 characters) is shown.

**TAG DESCRIPTION**

The full tag description (up to 40 characters) appears immediately below the tagname.

**STATUS AREA**

The status area appears immediately below the legend. This area is nearly identical to the group display status area described in **Status Area** in this chapter.

The second and third lines of the status message area contain the alarm status of a tag and mode messages, respectively. These lines are as described for the group display. Tables 4-1 and 4-2 provide descriptions of the messages which may appear on these lines.

The alarm and lock mode indicators function as described for the group display.

**INFO PUSHBUTTON**

The *Info* pushbutton appears at the top right corner of the point display. Click on this pushbutton to view the *Operating Parameters* window (Figure 4-30).

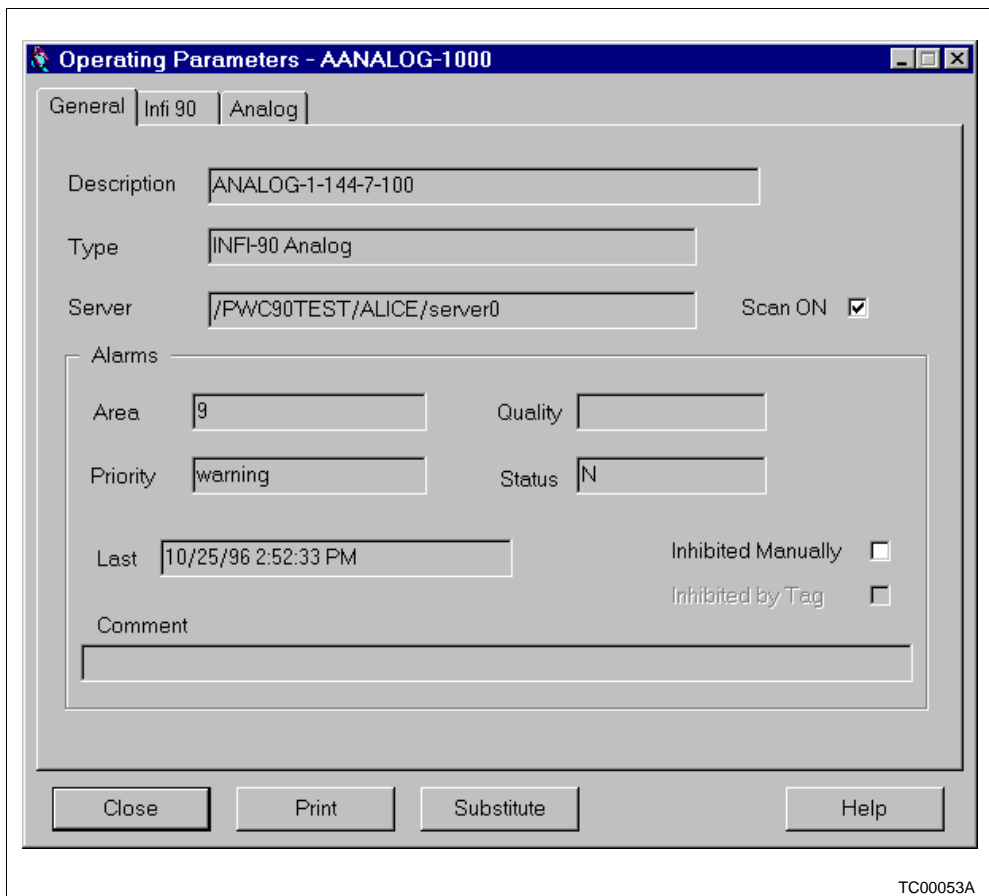

Figure 4-30. Operating Parameters Window

The *Operating Parameters* window allows the user to change the parameters for the tag. The *Operating Parameters* window contains a numbered list of parameters. The contents of this list is different for each module type; typical parameters include items such as alarm limit and deadband values and instrument ranges. Refer to [Section 13](#) for a full description of the *Operating Parameters* function.

**PARAM PUSHBUTTON**

The *Param* pushbutton appears at the top right corner of the point display. Click on this pushbutton to view the *Block Details* window (Figure 4-31). For a complete description of the

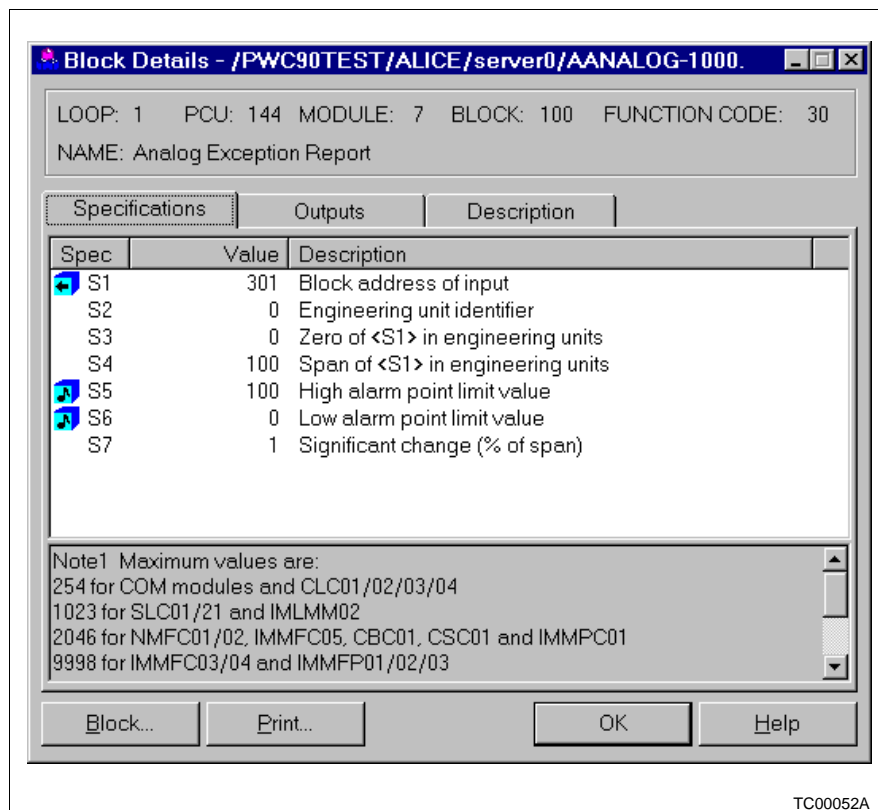

Figure 4-31. Block Details Window

block details function refer to [Section 17](#).

**PROCESS DISPLAY AREA**

The rest of the point display is called the process display area. The information shown in the process display area is determined by tag type.

The process display area for all analog tag types is similar to that for an ANALOG module, (Figure 4-29), as follows: on the lower right side appears the same information shown on the

group display (value bar, alarm bar, control buttons, etc.). To the left of that information appears a current trend display, which plots the process value of the point against time, every second, for up to two minutes. This trend begins plotting only when the point display is called up, and is not configurable. current trends are not stored; (refer to **TREND DISPLAYS** in Section 6). The current process value is shown, digitally, above the trend and to the right of the status area.

---

## SECTION 5 - LOGS

---

### INTRODUCTION

A log is used to collect and format data for use in reports and spreadsheet calculations. Two types of logs are available, network wide, on the Personal Work Center 90 (PWC90); these include:

- Event logs.
- Spreadsheet logs.

Event logs are used to examine the historical database and create lists of all events which occurred within a specific time span.

Spreadsheet logs are used to obtain data from, change, and put data into the INFI 90 OPEN global database, and to load the data into spreadsheets, allowing the user to format, store, and perform calculations using live process data. Spreadsheet log configuration is performed using Microsoft EXCEL.

Spreadsheet logs are network wide; i.e., a spreadsheet log can be configured or changed on any PWC90 console on the network, and the resulting changes will be copied to (synchronized with) all other PWC90 console, regardless of system type. This practice permits backup of the information from any node.

**NOTE:** Logs are sent to a printer device when generated. If a printer has been configured with the Device Type of FILE (see the *Personal Work Center 90 Configuration* instruction, or your system administrator), logs configured to print to that printer device will actually be sent to that file, rather than to an actual hardcopy printer.

---

### ACCESSING LOG PRINT

Log print is accessed by using the pull-down menus available from the system window *Menu* button. Position the pointer on the *Menu* button, and click the left mouse button. From the resulting pull-down menu, click on the *Print Log* option. The *Log Print* window (Figure 5-1) will appear.

Three radio buttons, each representing a different log type (event or spreadsheet), are located at the top of the *Log Print* window. By default, the summary log type is selected. To change the type of log to be printed, click on the radio button associated with the desired log type.

A list box appears below the log type buttons. The log name of each log configured (if any) for the selected log type will appear

in the list box. Use the scroll bars to view log names which extend beyond the viewing area of the list box.

At the bottom of the window, in addition to the usual *Close* and *Help* buttons, is a button labelled *Print*, used to print logs.

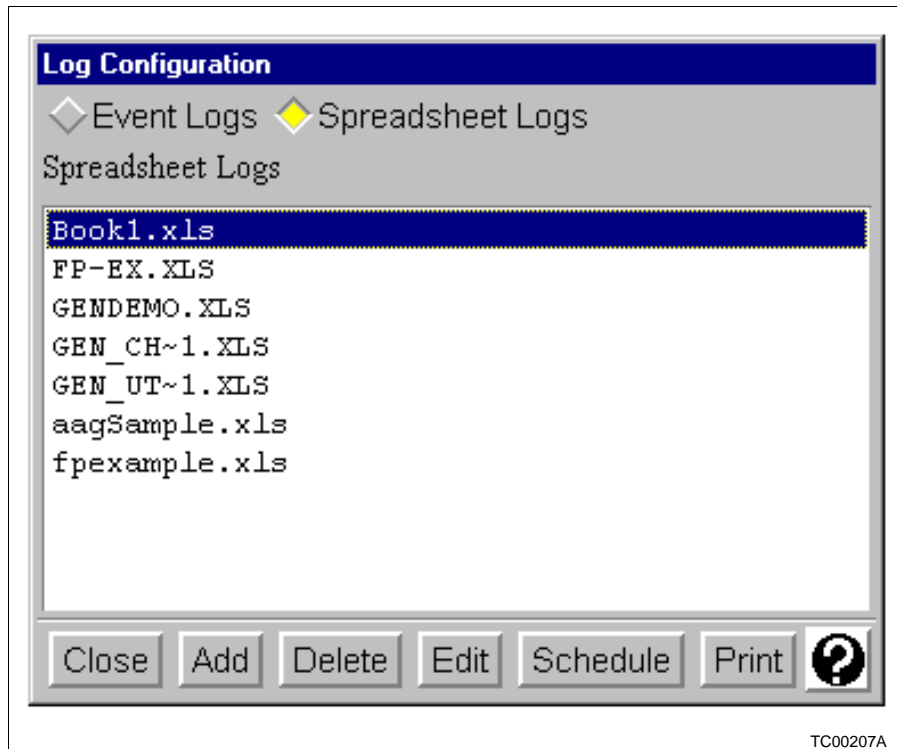

Figure 5-1. Log Print Window

## EVENT LOGS

Event logs are used to obtain information about events which occurred in the historical database within a specified time span. To select event logs for printing, click on the *Event Logs* toggle button, located at the center of the top of the *Log Print* window.

### Print Event Logs

The *Print* button on the *Log Print* window allows the user to print event logs on demand. First select the desired log from the list box by clicking on it; it will be highlighted. Next, click on *Print* to display the *print log* window (Figure 5-2).

The name of the event log appears first in the window, followed by a pushbutton labelled *Start Time*. The time and date displayed on the face of this button indicate the earliest time and date to be used for messages included in the event log. The default starting time is 19:00:00 31-DEC-69; to change this, click on the button. A pop up window appears, containing an entry box and the prompt:

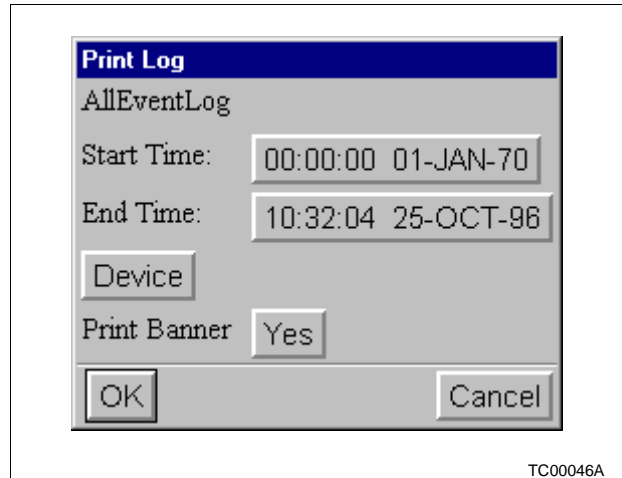

Figure 5-2. Print Log Window (Event Logs)

Enter Start Time (HH:MM:SS DD-MMM-YY).

Enter the desired starting time in the indicated format. Note that the 24 hour clock is used, and the month is identified by the first three letters of the month name. Click on *OK* to complete the operation, or click on *Cancel* to exit without changing the starting time.

Similarly, the second item on this window is a pushbutton labelled *End Time*. The time and date displayed on the face of this button indicates the latest time and date for messages to be included in the event log. The default end time is the current time and date.

The third item on this window is the *Device* button. If a device has been selected, the name of the device will be displayed to the right of the *Device* button. Click on this button to display the *Printer Selection* window. Highlight the desired printer by clicking on it, then click on *OK* to complete the selection operation, or click on *Cancel* to exit without changing the device selection.

---

## SPREADSHEET LOGS

Spreadsheet logs are used to obtain data from, change, and put data into the INFI 90 OPEN database. The data is loaded into spreadsheets, allowing the user to format, store, and perform calculations on live process data. The spreadsheet logs are accessed by clicking on the radio button labelled *Spreadsheet Logs*, located on the *Log Print* window (Figure 5-1). The list box in the *Log Print* window will list all spreadsheet logs which have been configured on the network.

**Print Spreadsheet Logs** The *Print* button on the *Log Print* window allows the user to print logs on demand. Click on this button to display the *Print Log* window.

The first item on this window is the log name. Below the log name is a *Device* button. If a device has been selected, the device name will be displayed to the right of the *Device* button. Click on *Device* to display the *Printer Selection* window. Highlight the desired printer by clicking on it, then click on *OK* to complete the selection operation, or click on *Cancel* to exit without changing the device selection.

Click on *OK* to complete the log selection operation, or click on *Cancel* to exit without changing the current selections.

---

## SECTION 6 - TREND DISPLAYS

---

### INTRODUCTION

Three types of trend recording are available on the Personal Work Center 90 (PWC90):

- Current trending.
- Historical trending.
- Archival trending.

The current, historical and archival trending functions display the values of one or more points in an analog trend format similar to that presented by a conventional strip chart recorder.

A current trend for each point appears as a part of the point display; current trends are not configurable, and are not stored. Current trending for a point exists only when the point is on display. Refer to **HIERARCHICAL PROCESS DISPLAYS** in Section 4 for a discussion of hierarchical displays, including point displays.

Long term trending is handled separately, and is available in two forms:

- Up to 1024 network wide historical trend displays are available on the PWC90 console. The configuration of these trends can be performed on any PWC90 console, and is then distributed to all other PWC90 consoles on the network. Refer to the **Personal Work Center 90 Configuration** instruction for details on the trend configuration procedure.
- The archive database utility permits historical data and historical block data to be transferred to a removable tape cartridge, creating a permanent record which can be retrieved and displayed at a later date as the archival (or archival block) database. Data from more than one archive tape can be restored; this material does not overwrite existing archival data, but rather is added to the existing data to become a part of the archival database. By clicking a single button on a trend display, the archival database can be specified as the data source, providing access to archival trends for the points configured on the trend display.

Any point that exists in the historical database and which can be converted to a numeric value can be trended.

Except for the text in the *Database Select* button, which indicates which database is being viewed (*HIST*orical or *ARCH*ival), the archival trend display format is identical to that of the his-

torical trend display. This section details the use of the trend display.

To call up a trend display, an operator window must be open and have keyboard focus. Click on *Select* option on the operator window menu bar, then click on *Trend* in the resulting pull-down menu (Figure 6-1).

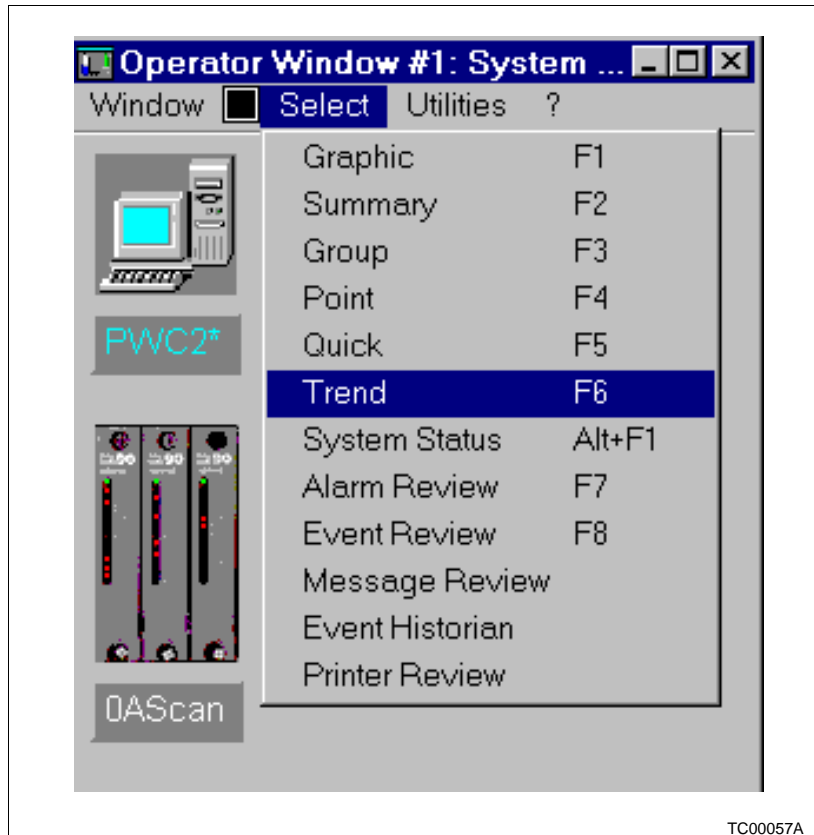

Figure 6-1. Selecting the Trend Option

A pop up window will appear (Figure 6-2), which contains an entry box and numeric keypad.

To enter the index number of the trend to be configured, click on the displayed keypad numbers to enter the trend index number, or click on the entry box and then enter the trend index number via the keyboard. The left arrow on the keypad corresponds to **Backspace** on the keyboard.

Trends can also be accessed using the *List* button on the *Trend Index Entry* pop up window. Click on *List* to display the *Select Trend* pop up window (Figure 6-3), which contains the number and (if assigned) the legend for all configured trends.

The *Select Trend* window allows the user to select the trend in a number of different ways.



Figure 6-2. Trend Index Entry Window

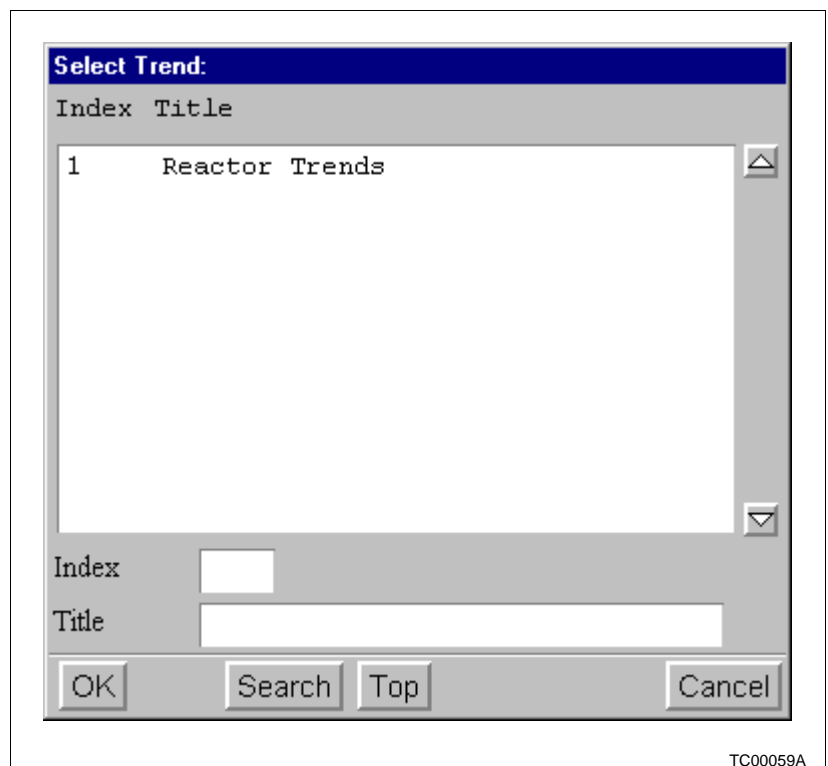

Figure 6-3. Select Trend Window

A trend can be selected from the list by first clicking on the trend name; it will be highlighted. Complete the selection process by clicking OK. The desired trend will appear, similar to the example in Figure 6-4. If the name of the desired trend is not visible, additional pages of the list can be viewed by clicking on the up and down arrows to the right of the list box.

If the trend index number is known, enter the number in the entry box labelled *Index*, then click on *OK*. The desired trend will be displayed.

If the trend name, or a portion thereof, is known, enter the known string in the entry box labelled *Title*, then click on *Search*. The first instance of a trend name containing that string will be displayed in the top line in the list box, and will be highlighted. Complete the selection process by clicking on *OK*.

To return to the top of the list, click on *OK*. The first item in the list will appear at the top of the list box.

Once selected, a trend display will appear, similar to the example in Figure 6-4.

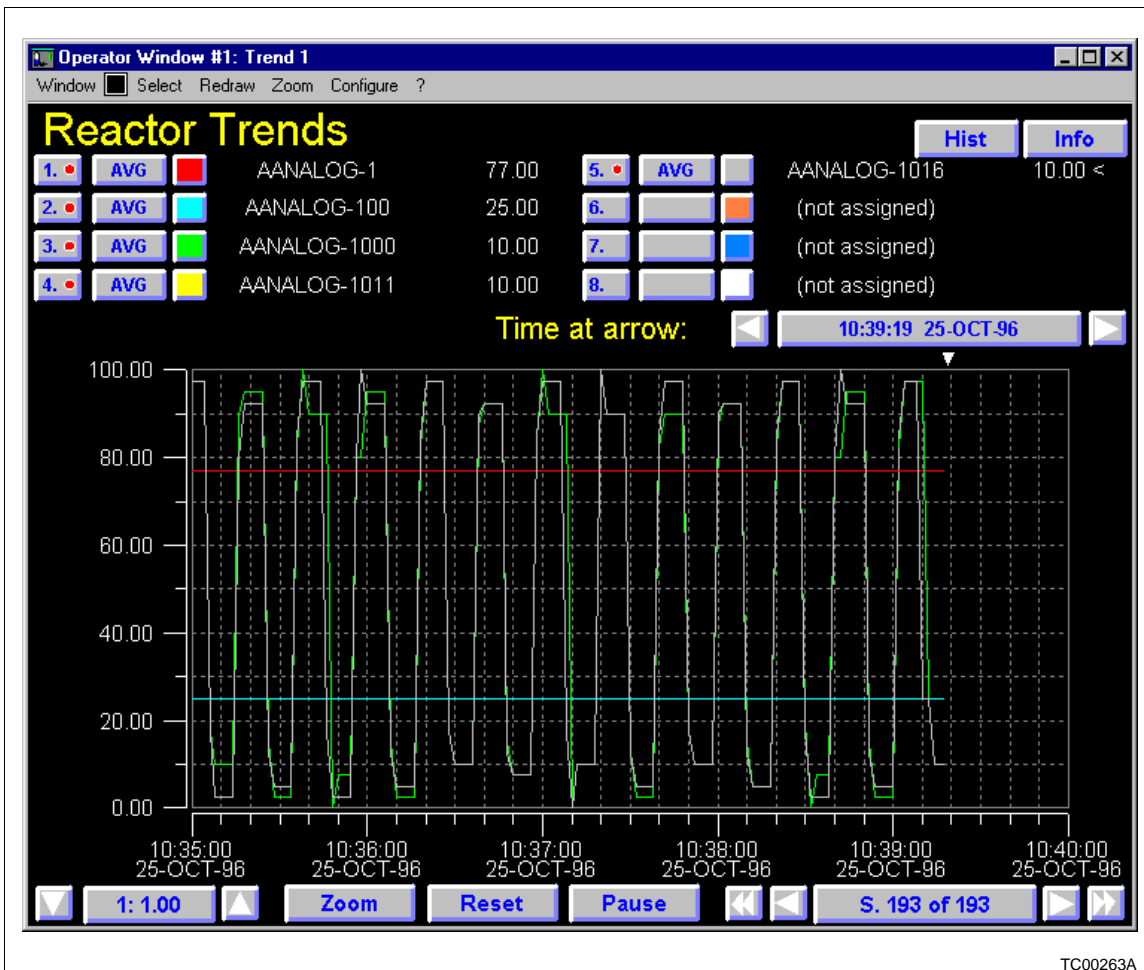

TC00263A

Figure 6-4. Trend Display Example

---

## TREND DISPLAY FORMAT

A trend display consists of numerous parts, each of which is described in detail in the following paragraphs. Briefly, the central area of the display is a trend graph containing colored traces which represent up to eight trendable variables.

Above the trend graph are eight sets of three buttons each, one set per trace; these buttons are used to manipulate individual traces or to replace the default range of the trend graph with the range for an individual trace. Below the trend graph are additional buttons; these buttons, which include the *Compression*, *Zoom*, *Reset*, *Pause*, and *Segment* buttons, affect all traces on the trend graph equally.

**NOTE:** The *Zoom* item on the trend display menu bar operates independently of the *Zoom* button on the trend display itself, which is described in **Zoom/UnZoom Button** in this section. Operation of the menu bar *Zoom* item is identical to that of the *Zoom* item found on graphic displays, as described in **ZOOM MENU ITEM** in Section 7.

---

### Trend Graph

The trend graph portion of the trend display occupies the lower two thirds of the operator window. Up to eight process variables can be displayed graphically as traces plotted on the trend graph. The vertical axis represents the percentage of display range, while the horizontal axis depicts the time base in minutes. Each process variable is plotted on the graph in a different color.

Using the *Trend Readout Arrow*, displayed in white at the top of the trend graph, the operator is able to point to any display value of a process variable on the graph. **Trend Readout Arrow** in this section describes the use of the *Trend Readout Arrow*.

---

### Time Base and Size of Display Window

The displayed time base of a trend display is separated into five sections, and is based on segment size. Segment size is a user configurable parameter, and is determined by the values entered to define the number of seconds and the number of points in a segment. The points referred to here should not be confused with the historical database point(s) for which values are being collected; rather points are the values collected for the historical database point, which then become points plotted as a trend trace. (Refer to the **Personal Work Center 90 Configuration** instruction for details on trend configuration.) By default, the number of points and the number of seconds are both set to 60, and display as five one minute intervals (segments) on the trend graph.

The PWC90 console locates the points which lie within each time interval. If one point is found, the value of the point is used to plot it on the trend display. If more than one point exists within the interval, the assigned display option (*MINimum*, *MAXimum*, *AVerage* or *INSTantaneous*) is used to calculate one value from all points which exist in the interval. This value is then plotted on the trend display. (If the *INSTantaneous* display option is used, the last value found will be used to plot the point on the trend graph.) The resulting value is used to plot the point on the trend display. If no points are found in an interval, no point is plotted for that interval.

This method of plotting trends permits greater flexibility in trend configuration. For example, points with different collection rates can be plotted on the same trend graph, and non periodic data can also be trended.

---

### ***Trend Readout Arrow***

The *Trend Readout Arrow* enables the operator to determine the collection time and value at any point where the arrow intersects with the horizontal axis of the graph. The *Trend Readout Arrow* is controlled by the left arrow and right arrow buttons which bracket the *Time At Arrow* button, located above the upper right corner of the trend graph. Clicking either of these arrow buttons causes the *Trend Readout Arrow* to move along the top of the trend graph in the indicated direction. Each time the button is clicked, the point of intersection between the *Trend Readout Arrow* and the trend graph moves to the next valid location of a collected value on the display in the direction selected.

---

### ***Time at Arrow Button***

The *Time At Arrow* button displays the specific time and date toward which the *Trend Readout Arrow* is pointing. The format used is HH:MM:SS DD-MMM-YY. This allows the operator to be precise when interpreting the data on the trend display. (When the display is refreshed the arrows shift along with the trace so that the display of the value for the time selected by the operator is maintained.)

To move the *Trend Readout Arrow* to point to a new time and date, click on *Time At Arrow*. A pop up window appears (Figure 6-5) which contains an entry box and prompts for a new time and date. (The *Trend Readout Arrow* cannot be moved to a time prior to the beginning of a trend.)

The new time and date can be entered in the format shown (HH:MM:SS DD-MMM-YY). If a field is omitted during entry, that field will default to the value used in the current *time at arrow*. An exception to this rule is the seconds (SS) field, which always defaults to 00 if no value is entered for the field. For

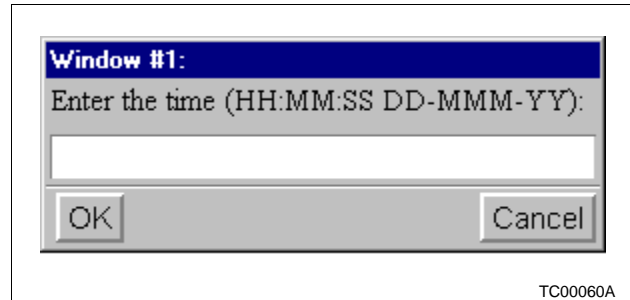

Figure 6-5. Time Entry Pop up Window

example, if the current *Time At Arrow* is 10:17:32 16-AUG-91, then entering:

**15-**

will cause the *Trend Readout Arrow* to move to 10:17:00 15-AUG-91.

It is also possible to move to a new time relative to that of the current *Value At Arrows*. To do so, prefix the number to be shifted with a plus or minus to indicate in which direction the movement is to take place. For example, to move the *Trend Readout Arrow* to the point on the trend graph which is ten minutes prior to the current location, enter:

**-:10**

To move the *Trend Readout Arrow* to the location five minutes after the current location, enter:

**+:5**

---

### **Trace On/Off Button**

A set of three buttons is provided on the trend display for each of the eight possible traces. The first button in each set is the *Trace On/Off* button, which displays the index number of the associated trace and contains an *On/Off* indicator. The *On/off* indicator is a red dot which is displayed when the trace is *On*. The indicator is not visible when the trace is *Off*. Click on *Trace On/Off* to cause the trace to alternate between the visible (*On*) and invisible (*Off*) states.

Each trace can be configured to be *On* (visible) or *Off* (invisible) by default when the trend is initially displayed. (**Personal Work Center 90 Configuration** instruction provides details on the configuration procedure.)

---

### **Display Option Button**

The *Display Option* button is the second of the three buttons provided on the trend display for each of the eight possible traces. The *Display Option* button allows the user to select the option which determines the form in which data is to be presented for that trace on the trend graph. These options include *MIN*imum, *MAX*imum, *AV*erage and *INST*antaneous.

If *MIN*, *MAX* or *AVG* is selected, the data collected during the collection interval will be used to calculate the value plotted on the trend graph. If *INST*antaneous is selected, the actual value of the data at the time of collection will be used to plot the value on the trend graph.

Click on *Display Option* to move through the choices. The face of the button will reflect the current choice in effect.

---

### **Trace Scale Button**

The *Trace Scale* button is the third button in the set of three associated with each trace. The face of this button indicates the color in which the trace is displayed. Click on this button to change the scale bar limits of the trend graph to reflect the specific high and low limits for the associated individual trace. The new scale bar limits will be displayed in the same color as the trace with which they are associated. To restore the original scale bar limits, click on *Trace Scale* a second time, or click on *Reset* (refer to **Reset Button** in this section).

---

### **Trace Tag and Atom**

The tagname and atom of the historical database point which is being trended appear to the right of the *Trace Scale* button.

---

### **Value at Arrow**

To the right of the trace tag and atom is a value which represents the *Value At Arrow*. This is the value of the historical database point trended by this trace at the time indicated by the location of the *Trend Readout Arrow*.

---

### **Value Precision Indicator**

Due to differences in collection rates, it is possible that no point was collected on the precise point in time indicated by the *Trend Readout Arrow*. In this case, the value displayed is an interpolated value. The value actually shown may have been collected slightly before or after the point in time indicated by the *Trend Readout Arrow*. The *Value Precision Indicator* is a one character field which follows the *Value At Arrow*. The character

displayed here provides information regarding the precision of the value:

- x Indicates a precise, actual value is displayed.
- << Indicates that the timestamp of the value displayed is actually prior to (older than) that indicated on the *Time At Arrow (Time at Arrow Button* in this section) button; or the PWC90 console is unable to interpolate the value.
- >> Indicates that the timestamp of the value displayed is actually after (newer than) that indicated on the *Time At Arrow (Time at Arrow Button* in this section) button.
- i Indicates an interpolated value, calculated using the closest values before and after that indicated on the *Time At Arrow* button.

---

### ***Database Select Button***

The *Database Select* button allows the user to toggle between the historical and archival databases when viewing trends. To do so, click on this button. The text on the face of the button will change to reflect which database (*HIST*orical or *ARCH*ival) is in use.

Remember that the archival database does not exist until archival database data has been restored from tape as described in ***Archive Historical Block Data*** in Section 11.

---

### ***INFO Button***

The *Info* button provides access to information on all traces configured on the trend display. Click on this button to display the *Trend Info* window for the trend(s) currently on display. While the format of the information presented may vary slightly, depending on the kind of point being trended, the same type of information is provided for most points, including:

- Historical database tagname.
- Range for the point.
- Timestamps of the first and last sample.
- Server tagname and atom.
- Collection rate.
- Storage rate.
- Collection option (MIN, MAX, AVG, INST).

- Identity of node from which the point data was collected.
- Identity of node on which the collected data was stored.
- Historical database legend for the point. (If no historical database legend has been configured for the point, the PWC90 console will use the point legend configured in the server; if no legend has been configured there, no legend will be displayed).

---

### ***Compression Button and Arrows***

The compression ratio is the ratio between the current segment size and the configured segment size. The current compression ratio in use is displayed on the face of the button; i.e., 1:1.00 (one point to one second).

The *Compression* button is located in the lower left corner of the trend display, below the trend graph; a down arrow is located to the left of the *Compression* button, an up arrow is on the right. The current compression ratio in effect is displayed on the face of the *Compression* button. Click the up or down arrow to raise or lower the compression ratio to a predefined ratio. Predefined ratios are:

1:0.10  
1:0.25  
1:0.50  
1:1.00  
1:2.00  
1:5.00  
1:10.00  
1:20.00  
1:50.00

In the above list, the compression value is shown to the right of the colon. To enter a new compression value directly, click on *Compression*. A pop up window (Figure 6-6) appears. This window contains an entry box, an *OK* and a *Cancel*.

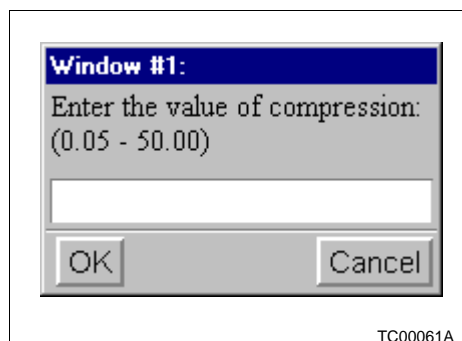

Figure 6-6. *Compression Value Entry Window*

Click on the entry box to call up the text entry cursor, then enter the compression value to be used. Click on *OK* to complete the operation, or *Cancel* to exit without selecting a different compression value. If the value entered is outside of the range (0.05 to 50), the following error message will be displayed in a pop up window:

*Value not in range.  
(0.05 - 50.00)*

Click on *OK* in the pop up window to close it. Also, if the combination of the segment size configured for the trend and the compression value entered will result in too many points being plotted in a segment, the following error message will be displayed in a pop up window:

*Segment size too large.*

Click on *OK* to close this error pop up, and enter a lower compression value. This condition can occur when the configured segment size is larger than the default segment size (60 seconds).

Caution must be exercised when interpreting data displayed on a compressed display. It is easy to see by experimenting with viewing the same trend display using a number of different compression ratios that, although all the displays are correct representations of the compressed trend data, the traces displayed may be deceiving if not viewed with care. When the display options *MINimum*, *MAXimum*, or *AVerage* are in effect, remember that the values of the points between the displayed points could have varied widely. Even when *INSTantaneous* is the display option in effect a compressed display can be subject to misinterpretation (the examples which follow in this section illustrate how this is true for *INSTantaneous* values).

When viewing a compressed trend display of process variables, the value of which repeat over time, be especially careful. Aliasing can cause the trace for the signals to appear as a straight line, as a magnified duplicate of the original trace, even as a mirror image of the original trace.

To envision the reason for the generation of these possibly misleading traces, the way in which compressed displays are drawn must be considered. Every *n*th sample is plotted on the graph as a point and the points are connected by straight lines. Therefore, the position of the extracted points along the original trace will affect the shape of the trace on the new compressed display. For example, if an historical trend is established to display a periodic signal which repeats every 60 seconds, and a collection rate of ten seconds is configured, then the display will show six points per period of the signal (Figure 6-7). If this trend is compressed six times, the display will show only every sixth sample. The resulting display will be

a straight line since every sixth sample has the same value (Figure 6-8). If the display is compressed seven times the resulting display will be identical to the original since the value of the eighth sample (first sample plus seven) is the same as the value of the second, the value of the fifteenth point is the same as the value of the third, etc. (Figure 6-9). If the display is compressed five times, the resulting display will be the mirror image of the original waveform (Figure 6-10).

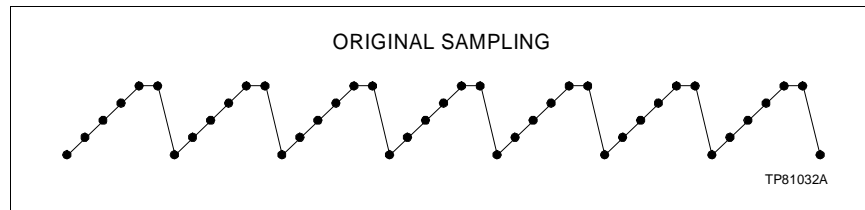

Figure 6-7. Original Waveform

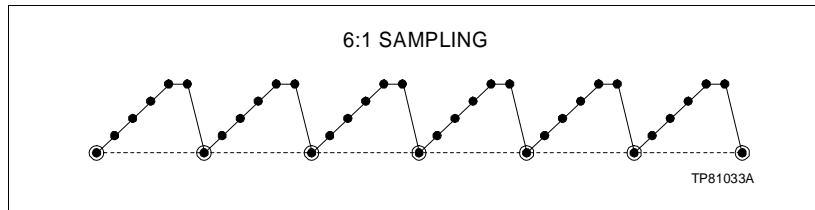

Figure 6-8. Compressed Waveform - 6:1 Compression

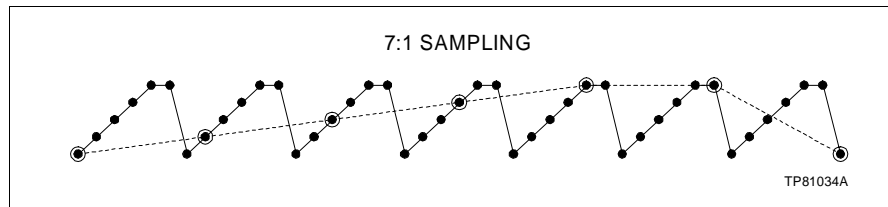

Figure 6-9. Compressed Waveform - 7:1 Compression

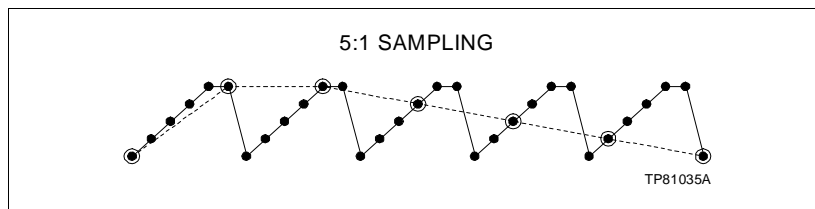

Figure 6-10. Compressed Waveform - 5:1 Compression

### Trend Compression Speed Factors

There are several factors which affect the amount of time necessary to perform trend compression. The most important factor is the amount of data to be processed. To a lesser extent, both the location of the data with respect to the location of pro-

cessing, and the speed of the PWC90 console performing the processing, have a measurable influence.

Trend compression time is based on the amount of data that is processed. If all points on the trend display contain the same amount of data to be compressed, each will take the same time to compress. However, it is possible to have points with different densities displayed on the same trend (i.e., the trace from pen one reflects data collected at one second intervals, while the trace from pen two reflects data collected at five minute intervals). When this situation exists, extra care is needed when comparing compression times.

Where trend compression is a common operation, it is better to do the compression in the historical database, in which case it is done as a background task. This is done via the configuration of the historical database points, where the periodic collection rate (one second, two seconds, etc.), the storage rate option (one, two, five, etc.), and the collection option (minimum, maximum, average, or instantaneous value) are configured. (historical database configuration is discussed in the ***Personal Work Center 90 Configuration*** instruction.)

Briefly, these configuration options make it possible to do much of the compression within the historical database. For instance, an initial compression ratio of ten to one can be achieved within the historical database by storing a value that is the average of ten collection samples (collected at one second), and displayed on a trend display so that one value is displayed for each point on the plot. Subsequent compression of the trend display using a compression ratio of 1:50 will be much faster, and will yield exactly the same trace as that displayed when averaging of all collection samples and compression (using a 1:50 compression ratio) are performed via the trend display. By storing a value that is the average of ten samples, the total amount of data extracted from the historical database and averaged is one tenth of what would be required if every sample were stored and averaged on the trend display.

When the PWC90 console on which the historical database data is stored is different from the PWC90 console that is controlling the operator window which contains the trend display, the data must travel across the system network in order to be displayed. This can cause a noticeable delay when there is a large amount of data to be transferred. It can take over twice as long to compress a large trend under these circumstances. Using the historical database configuration to perform data compression as described above and thus transferring less data across the network becomes even more important under these circumstances.

The speed with which trend compression is performed is also affected by the speed of the PWC90 console computer being used to view the trend display. The processing speed of the

PWC90 console computer is affected both by the load placed on the CPU and the type of hardware in which the PWC90 software is installed. Talk to your system administrator if you have questions about the hardware platform in use at your site.

---

### **Zoom/UnZoom Button**

The *Zoom/Unzoom* button allows the user to enlarge a portion of the trend graph by choosing two opposing corners of a rectangular area which is to be enlarged; the chosen section will then be resized to fill the entire area of the trend graph. To use this feature, click on *Zoom*. A prompt appears above the upper left corner of the trend graph:

Select the first zoom point:

Position the pointer and click on the point which will serve as the first corner of the rectangle. The prompt changes to:

Select the second zoom point:

Move the pointer to the location which is to serve as the opposite corner of the rectangle; a white outline appears to illustrate the area which will be enlarged. Click on the second zoom point. The area so defined is enlarged to fill the entire trend graph, and the *Zoom* button changes to read *Unzoom*.

To return the trend graph to its original state, click on *Unzoom*.

**NOTE:** The *Zoom* item on the trend display menu bar operates independently of the *Zoom* button on the trend display itself. Operation of the menu bar *Zoom* item is identical to that of the *Zoom* item found on graphic displays, as described in **ZOOM MENU ITEM** in Section 7 of this instruction.

---

### **Reset Button**

The *Reset* button is used to return the trend display to its original state, as it appeared when the display was first called up. For example, if the *Trend Scale* key has been used to change the scale bar limits to those of the *Trace High* and *Trace Low* for a particular trace, click on *Reset* to return the scale bar limits to the original settings for the display.

The *Reset* key can only be used to return to the initial settings of the trend display currently on view. The *Reset* key cannot be used to reset a change made via the *Database Select* button (refer to **Database Select Button** in this section), which allows the user to change from historical to archival trends, and vice versa.

---

### Pause/Resume Button

The text on the face of the *Pause/Resume* button indicates the state which will occur when the button is clicked. Clicking on this button when it reads *Pause* will cause the screen to stop updating, effectively freezing the display for reading and analysis; the text on the button changes to *Resume*.

Clicking on this button when it reads *Resume* causes the display to resume updating.

---

### Segment Button and Arrows

The trend graph is divided into five segments. The *Segment* button is located in the lower right corner of the trend display, and is flanked by both a double arrow and a single arrow button on either side. Click on one of the single arrow buttons to shift the trend display one segment in the indicated direction. Click on one of the double arrow buttons to shift the trend display four segments in the indicated direction. Note that the trend display is actually composed of five segments; one segment is used for overlap when using the double arrow buttons.

The face of the *Segment* button displays the current segment number and the total number of segments in the following format:

**S. nnnn of tttt**

where **S.** stands for segment, **nnnn** is the number of the segment which currently contains the *Trend Readout Arrow*, and **tttt** is the total number of segments available.

To go directly to a particular segment, click on *Segment*. A pop up window (Figure 6-11) appears. This window contains an entry box, an *OK* button and a *Cancel* button.

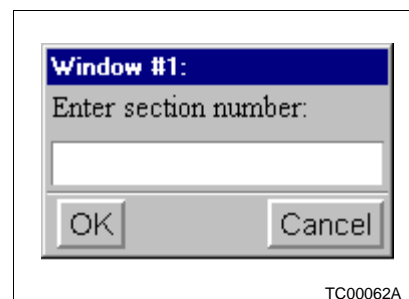

Figure 6-11. Section Number Entry Window

Click on the entry box to call up the text entry cursor, then enter the number of the segment to be displayed. Click on *OK* to complete the operation, or click on *Cancel* to exit without selecting a different segment number.

---

## SECTION 7 - GRAPHICS

---

### INTRODUCTION

This section describes the use of graphic displays on the Personal Work Center 90 (PWC90) console, including:

- Accessing graphics.
- Control through graphics.
- Display vectoring.

There are 1024 custom graphic displays available on the PWC90 console. Graphics are configured to display process values, to allow for process values to be changed, and to provide a graphical representation of the process. A typical graphic, such as the example in Figure 7-1, contains a pictorial representation of a section of the process in a plant, using symbols, bars, lines, text, and so on. All of the graphical objects used in the group and point displays (such as pushbuttons, sliders, bargraphs, and trends) can be used on graphics.

Values (such as temperatures, pressures and alarm states) from the plant process can cause changes to text, colors, or shapes on a graphic. Values are updated every second in the operator window which has keyboard focus. In all other operator windows, updates occur every two seconds.

A graphic can contain pushbuttons and other objects which allow user interaction via the mouse and/or keyboard. For example, a graphic may contain a pushbutton with the label *ACK*, which appears when a point goes into alarm and which, when clicked, acknowledges the alarm. Two pushbuttons frequently used on graphics are the control pushbutton and the vector pushbutton, described below.

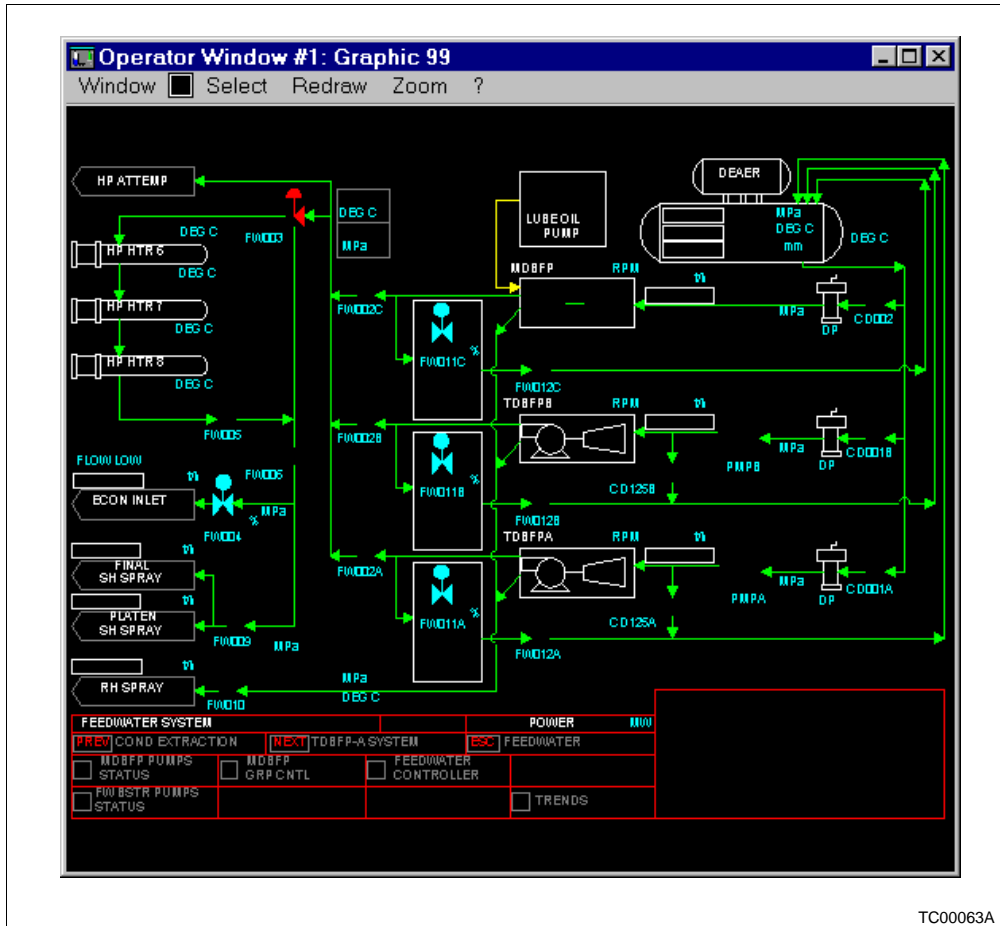

Figure 7-1. Typical Graphic Display

### ACCESSING GRAPHIC DISPLAYS

With an operator window open and given keyboard focus, press **F1**. A pop-up window will appear, which allows the user to enter the index number of the desired graphic display.

Alternatively, the mouse can be used (instead of **F1**) to display this pop-up window. Again, an operator window must be open; use the mouse to click on the *Select* option on the operator window menu bar. This action both confers keyboard focus on that window, and causes a pull-down menu to appear. Click on the *Graphic* item in the pull-down menu.

If the number of the desired graphic is not known, or if you wish to first view a list of available graphic displays, click on *List* on the pop-up window. The original pop-up window will be replaced by a new one entitled *Select Graphic* (Figure 7-2), which contains a list box which lists the number and legend of each available graphic display.

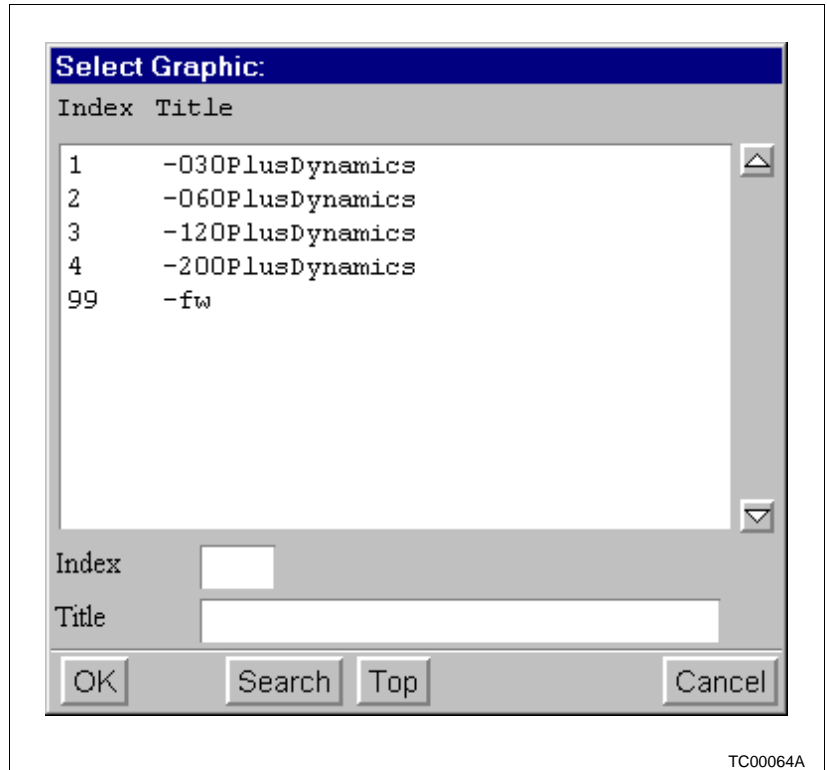

Figure 7-2. Select Graphic Pop-Up Window

Click on the desired item in the list box to highlight it, then click on *OK* to complete the selection operation, or click on *Cancel* to exit without selecting a graphic. Other options on the *Select Graphic* pop-up window include a *Search* button, which allows the user to search the list for a graphic number, or an alphanumeric string representing all or part of a graphic legend; the graphic with the specified number (entered in the *Index* entry box) or the first entry encountered containing the specified string (entered in the *Title* entry box) will be placed at the top of the list. A *Top* button is also supplied; click on this button to display the beginning of the list in the list box.

After a graphic display has been selected, use **Pg Up** and **Pg Dn** to move between adjacent graphic displays.

**CONTROL THROUGH GRAPHICS**

A process can be controlled from a graphic through the use of a control pushbutton, a square, labeled button. The default label is **C** but buttons with other labels may be used. Typically, a control pushbutton is located near another graphical object on the graphic display, such as a valve, which is to be controlled (Figure 7-3). A graphic display can contain more than one control pushbutton.

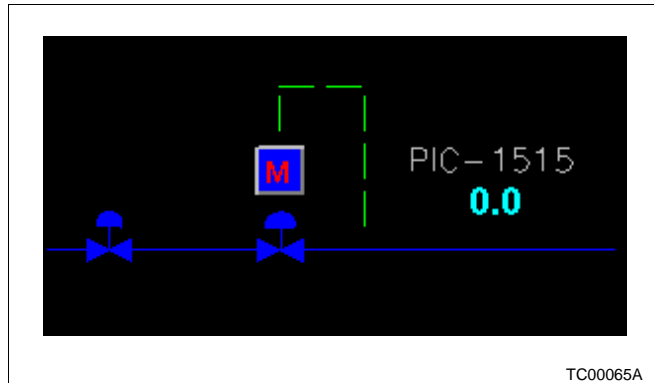

Figure 7-3. Graphic Display with Control Pushbutton

A control pushbutton is configured with the name of the tag (process point) to be controlled. Clicking on a control pushbutton opens a pop-up control window (Figure 7-4) containing a single tag group display for this point.

The appearance and use of the display in the control window varies according to the module type of the tag, as described in **GROUP DISPLAY** in Section 4. Typically, the display in the control window allows process values (i.e., a setpoint) to be changed by the use of sliders or pushbuttons. A pushbutton near the top of the display contains the tagname. Clicking this pushbutton closes the pop-up control window and replaces the graphic with the corresponding point display.

The title bar of the pop-up control window identifies its parent operator window by number. Two pop-up control windows can be opened at a time from one operator window. Click on **OK** to close a pop-up control window. The pop-up control window can be moved and resized in the normal fashion.

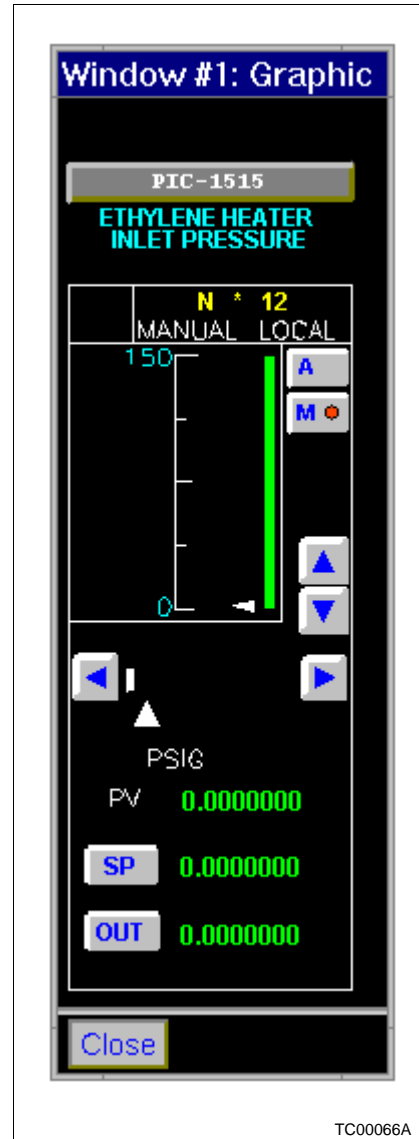

Figure 7-4. Control Window

**DISPLAY VECTORING**

The display vector pushbutton is shown in Figure 7-5.



Figure 7-5. Display Vector Pushbutton

Display vector pushbuttons are incorporated in a graphic when it is configured; for example, the graphic in Figure 7-1 contains display vector pushbuttons at the lower left side of the display.

Click on a display vector pushbutton to change the display in the operator window from the current graphic to a different display, which has been specified during configuration. This new display can be another graphic, or a display of a different type. For example, one display vector pushbutton can be configured to vector to graphic #12 and another can vector to summary #10. Typically, a label appears next to the vector pushbutton identifying the vector display.

By default, the new display appears in the window in which the vector pushbutton is located; to cause the new display to appear in a different operator window, use the drag and drop mode of operation; i.e., instead of clicking on the vector pushbutton, position the pointer on it and press the left mouse button. Continue to hold down the mouse button and drag the pointer until it is completely inside the frame of the operator window in which the new display is to be dropped. Release the mouse button, and the new display will be dropped into the window.

**NOTE:** Attempts to drop the display in anything other than an operator window (i.e., a pop-up window, the system window, and so on) will cause the PWC90 console to beep and the operation to terminate. Similarly, if the pointer is on an operator window frame (instead of inside the window or on the title bar), the PWC90 console will beep and the operation will terminate.

---

**ERROR INDICATION**

If an error occurs when a graphic is on display, the error indicator (Figure 7-6) appears in the center of the operator window.

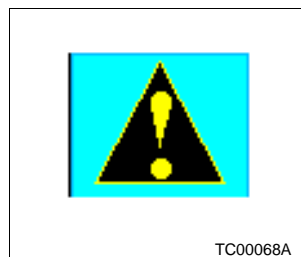

Figure 7-6. Error Indicator

Click on the error indicator to open a pop-up window, entitled *DBA Errors*, which contains messages describing the error(s). The following are the most common causes of errors:

- A process value used by the graphic cannot be accessed. The message supplies further details on the problem.

- The graphic was not configured completely. This results in variable not defined messages.

To quickly determine which object on the graphic is associated with a particular error message, click on the message in the *DBA Errors* pop-up window. The associated object on the graphic will flash rapidly several times in response. Be aware that the flashed object can be hidden behind the *DBA Errors* window. If no object appears to flash when the error message is clicked on, move the *DBA Errors* window and click on the error message again.

The error indicator always appears in the center of the graphic. If you have used the *Zoom/Pan* feature, the error indicator may not appear on the visible part of the graphic. Similarly, use of *Zoom/Pan* may cause the flashed object to be outside the visible part of the graphic. Use the *Zoom To Fit* function to assure that the entire graphic is visible in the operator window.

---

### ALARM ACKNOWLEDGMENT

A graphic can allow alarm acknowledgment. For example, a graphic can be configured so that a pushbutton labelled *ACK* appears when a tag in alarm needs acknowledgment. Click on the pushbutton to acknowledge the alarm and remove the pushbutton from the display. Note that this is a user configurable option; if you have questions on how graphics have been configured on your system, consult your system administrator.

Alarms can also be acknowledged from a graphic by pressing **Alt-F10** (on the keyboard), or by selecting the *Acknowledge* item on the *Window* pull-down menu. Each point which needs acknowledgment, and whose *ACK* atom is referenced by the graphic, is acknowledged.

---

### ZOOM MENU ITEM

By default, the entire graphic display is always shown in the operator window when the graphic is first called up.

The *Zoom* item on the menu bar of the graphic display provides access to the *Zoom* and *Pan* operations, which are used to change:

- Portion of the graphic which is visible in the operator window (*PAN*).
- Amount of the graphic display which can be visible in the operator window, known as the view size (*Zoom*).

The view size always has an aspect ratio four (wide) by three (high), to maintain correct proportions of models during scaling operations.

To access the *Zoom* and *PAN* functions, click on the *Zoom* item on the menu bar of the graphic display. The *Zoom/Pan* window (Figure 7-7) will be displayed.

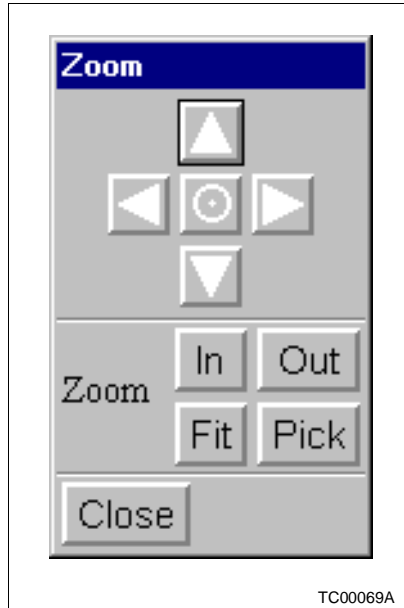

Figure 7-7. *Zoom/Pan* Window

The top portion of the *Zoom/Pan* window provides *Pan* functions, while the bottom part of the window is devoted to the *Zoom* operation.

If the *Zoom/Pan* window is on display and the display in the operator window is changed to any type of display other than another graphic or a trend, group or point display, the *Zoom/Pan* window will automatically be closed.

**NOTE:** Changes to the view size made in a graphic will not be saved as part of a CRT context key or Quick key setting; when a graphic display is called up by either of these methods, a zoom to fit operation (described in ***Pan Operations - Up, Down, Left, Right, Center*** in this section) will automatically be performed.

---

***Pan Operations - Up, Down, Left, Right, Center***

The *Pan* operations (*Up, Down, Left, Right, Center*) are used to change the portion of the view shown in the operator window; they do not change the view size.

Each of the *Pan* functions is represented on the *Zoom/Pan* window by a button. The face and location of the button indicate its function. The face of each of the directional operations (*Up,*

*Down, Left and Right*) contains an arrow pointing in the appropriate direction, and each button is located in the appropriate position around the *Center* button. The face of the *Center* button contains a bull's eye.

Each click on one of the directional *Pan* buttons moves the visible portion of the view in the selected direction by 1/3 of the corresponding view dimension.

After the *Center* button is clicked, the pointer assumes the shape of a bull's eye. The next click in the graphic display will center the view on the point clicked.

---

### **Zoom Operations - In, Out, Fit, Pick**

The *Zoom* operations (*In, Out, Fit, Pick*) change the apparent size of the graphic which appears in the operator window.

A graphic display can have a maximum size of 400 units by 300 units, and a minimum size of 20 by 15 units. The number of units in a graphic is normally invisible except during configuration (discussed in the **Personal Work Center 90 Configuration** instruction); however, attempts to *Zoom IN* or *Out* beyond the minimum or maximum size will have no effect, and the view size will remain at the minimum or maximum.

**NOTE:** Units are visible only during configuration, and because installed graphics are automatically zoomed to fit when loaded in the operator window, use of units is invisible.

Each time the *Zoom In* button is clicked, the view size is reduced by 62%. The center of the view remains unchanged. Objects in the graphic which are visible appear correspondingly larger. If the view has been fully zoomed in, no further change occurs to the view size.

Each time the *Zoom Out* button is clicked, the view size is enlarged by 62%. The center of the view remains unchanged. Objects in the graphic which are visible appear correspondingly smaller. If the view has been fully zoomed out, no further change occurs to the view size.

Click on *Zoom Fit* to adjust the view size by automatically zooming out (or in) so that the entire model is visible and fills the working view. If there are no objects outside the current view size, the view size will zoom in order to make the objects present fill the operator window (however, it will not zoom in beyond the default view size, which is 100 units by 75 units). Each time an installed graphic is displayed in an operator window a *Zoom Fit* operation is automatically performed.

The *Zoom Pick* button allows the user to select two diagonal corners (i.e., the lower left and upper right corners) of the box which encompasses the desired view size. The rectangle result-

ing from these selections is called the zoom box. If a zoom box is smaller than the minimum permissible view size, the view size will remain unchanged.

**NOTE:** The contents of the graphic display in the operator window after a Zoom Pick operation may not reflect exactly the contents of the zoom box used to make the selection. This is because the graphic is restricted to an aspect ratio of four (wide) by three (high), while the zoom box is not. In order to reconcile the two, the 4 x 3 Aspect Ratio is applied to the largest dimension of the zoom box selected by the user.

---

### ***Zoom and Pan Operations in Pop-Up Graphic Windows***

*Zoom* and *Pan* operations are also available in pop-up graphic windows which are accessed via model pop-up pushbuttons which appear on graphic displays. A *Zoom* button appears at the bottom of such pop-up windows; click on it to access the *Zoom/Pan* window. The *Zoom* and *Pan* operations can be performed as described above. A *Zoom to Fit* operation is automatically performed on such pop-up windows when they are first displayed.

**NOTE:** Zoom/pan operations are *not* available in pop-up controller windows.

---

### ***Resizing the Zoomed/Panned Operator Window***

When an operator window (or pop-up graphic window) is resized, the view size is not changed. However, if the shape of the window is changed, (i.e., made narrower, wider, taller, or shorter) more of the view may be visible than before. The objects in the view will appear larger if the window is made larger, or smaller if the window is made smaller.

---

## SECTION 8 - PROCESS ALARMS

---

### *INTRODUCTION*

A process alarm is generated when a process variable is in an abnormal condition. Process alarms are displayed in the first two lines of the mini alarm window and are accompanied by audible alarms. A complete list of process alarms is contained in the *Alarm Review* display. Like other messages generated on the system, process alarms are stored in the historical database and can be viewed on a Personal Work Center 90 (PWC90), or logged to a printer using the event historian (refer to **EVENT HISTORIAN** in Section 9). Process alarms can also be logged to a printer as they occur.

---

### *PROCESS ALARMS IN THE MINI-ALARM WINDOW*

Process alarms are displayed in the top two lines of the mini-alarm window. If more unacknowledged process alarms exist than can be displayed in the mini-alarm window, then the message +ALARMS appears in the title bar of the mini-alarm window.

---

### *Process Alarm Priorities*

Each process alarm is assigned a priority level (from 1 to 16 with level 1 being the highest) during configuration. The priority determines the importance of an alarm and the position in which it is displayed in the mini-alarm window. The priority also determines the color in which the alarm is presented and the type of audible alarm which accompanies it.

---

### *Audible Alarm Format*

Audible alarms are available in two formats on the PWC90 console:

- Steady beep.
- Rapid beep.

The rapid beep is used for alarms with a high priority, while the steady beep is used for lower priority alarms. The priority level which marks the division between the high and lower priority audible alarm formats can be configured by the user, as described in **Personal Work Center 90 Configuration** instruction. For details on the configuration of this item on your system, consult your system administrator.

Data contained in the mini-alarm window is automatically filtered by the filtering mask configured for the user currently

logged in on the PWC90 console and by any additional filtering performed by the user (refer to **Filtering Alarms in the Mini-Alarm Window** in this section). This means that not all PWC90 consoles will necessarily receive the same set of alarms and messages. When there are no unacknowledged process alarms, system events or messages in the mini-alarm window on a particular PWC90 console, the audible alarm will be automatically turned off for that PWC90 console until the next unacknowledged alarm or message appears in the mini-alarm window.

**NOTES:**

1. There can still be unacknowledged alarms on the system that are not visible on the user's PWC90 console, due to the filtering configuration.
2. A Silence button (with a Horn icon on the button face) appears on the mini-alarm window title bar when audible alarms exist. This button corresponds to **Alt-F11** on the keyboard, and can be used to silence (but not acknowledge) alarms for the node on which it appears.

---

**Acknowledging Alarms in the Mini-Alarm Window**

At the far left of each process alarm line in the mini-alarm window is an alarm acknowledge button. An *A* displayed on the face of the button as a request for acknowledgment, indicating the alarm is unacknowledged. If the face of the button does not contain an *A*, the alarm has been acknowledged. To acknowledge a process alarm, click on alarm acknowledge.

The first process alarm in the mini-alarm window can also be acknowledged by pressing **Alt-F6**. Note that only the first process alarm can be acknowledged in this manner.

---

**Filtering Alarms in the Mini-Alarm Window**

The filter button is located at the right end of the title bar of the mini-alarm window. The label displayed on the face of this button indicates whether alarms displayed in the mini-alarm window have been filtered. If all alarms will be displayed, the face of the button will display the word *Filter*; if some alarms will not be displayed, the label reads *Filtered*. Click on this button to display a pop-up window containing a user interface. This window contains options which can be used to filter process alarms by priority, area and PWC90 console.

The main display area of this window is divided in two portions, the left side is labelled *Message Class*, and contains buttons which display the available message class names. The right side of the display contains a list box, which lists the message types available for the selected message class. Filtering is accomplished as described in **Filtering Alarms** in this section.

## PROCESS ALARM REVIEW

The *Alarm Review* display allows the operator to view multiple process alarms in a single display; the actual number of alarms which can be seen depends on the size of the operator window in which they are displayed.

### Accessing the Alarm Review Display

The alarm review display is accessed by using the pull-down menu available from the operator window menu bar *Select* option. Position the pointer on the *Select* option, and click the left mouse button. From the resulting pull-down menu, click on the *Alarm Review* item. The *Alarm Review* window (Figure 8-1) will be displayed.

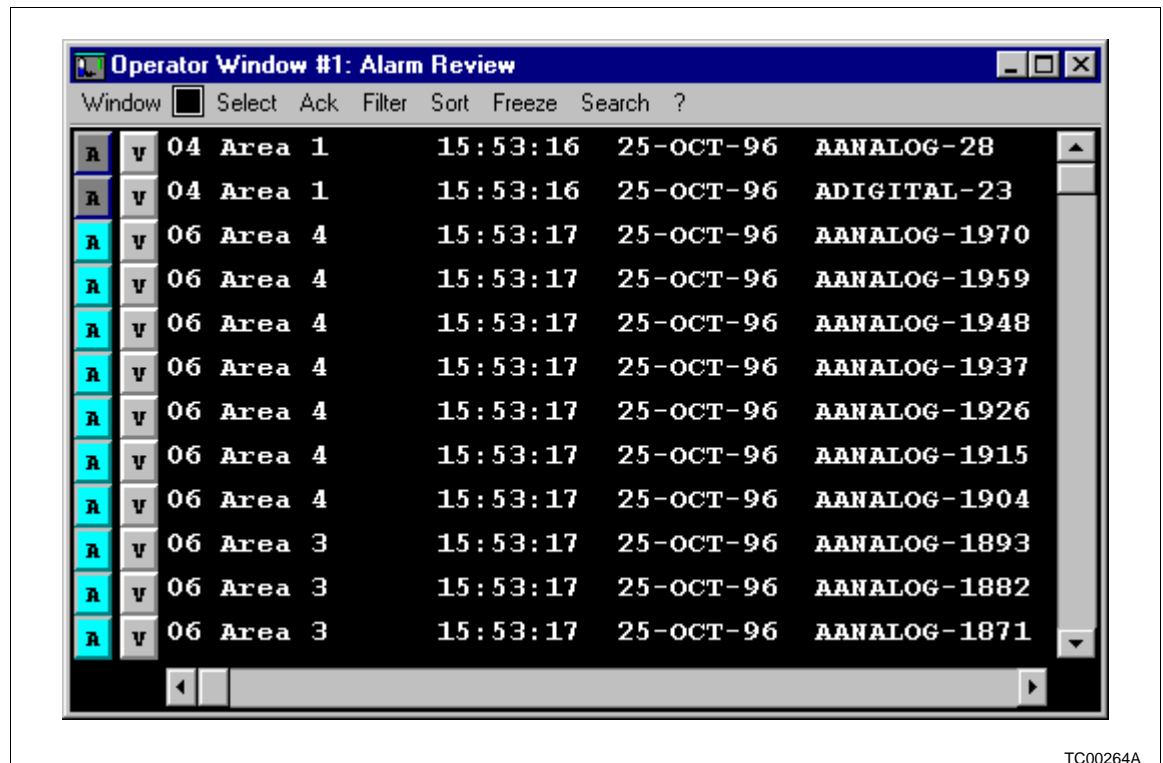

TC00264A

Figure 8-1. Alarm Review Window

The *Alarm Review* display is filtered to reflect the access configured for the user currently logged into the PWC90 console. The menu bar of the alarm review display contains a *Filter* button. Like the *Filter* button on the mini-alarm title bar, the label displayed on the face of this button indicates whether alarms displayed in the mini-alarm window have been filtered. If all alarms will be displayed, the face of the button will display the word *Filter*; if some alarms will not be displayed, the label reads *Filtered*. By default, the alarms are sorted primarily by priority. Alarms which have the same priority are further

sorted by time. Either the oldest or newest alarm can be first in time order, depending on the option selected when the system was configured. A quick way to see the default at a glance is to click on the *Sort* option on the alarm review display menu bar and view the resulting display; the *Sort* option is described in ***Sort Alarms in the Alarm Review*** in this section.

**NOTE:** Alarms that existed when the PWC90 console was booted or restarted are shown with a timestamp of 00:00:00 and a blank date field. This unique timestamp is necessary because the time when the alarms occurred is not known when the PWC90 console is booted, or is lost when the system is shutdown during a restart.

---

### ***Alarm Review Display Acknowledgment***

Each line in the *Alarm Review* display contains data pertaining to one particular alarm. At the far left side of the line is the *Alarm Acknowledge* button. An *A* displayed on the face of the button is a request for acknowledgment, indicating the alarm is unacknowledged. If the face of the button does not contain an *A*, the alarm has been acknowledged.

Alarms on the *Alarm Review* display can also be acknowledged using the *ACK* option on the *Alarm Review* menu bar. Clicking on this option causes a pull-down menu to appear. This menu is used to acknowledge multiple alarms by:

- Priority.
- Area.
- PWC90 console.

Click on the desired item; a pop-up window containing a text entry box and a keypad, similar to the one in Figure 8-2, will be displayed. (The label to the left of the text entry box will differ, depending on the parameter selected.)

Enter the number of the priority, area, etc., for which alarms are to be acknowledged. Click on *OK* to complete the operation; all alarms visible in the *Alarm Review* display for that priority, area, etc., will be acknowledged.

To acknowledge all alarms visible in the *Alarm Review* display, click on *All Alarms*, the last item in the *ACK* pull-down menu (or just press the **Alt-F10** if the operator window containing the alarm review display has keyboard focus). A confirmation box will appear, which asks:

*? Acknowledge All Alarms on Display.*

Click on *Yes* to acknowledge all alarms visible in the *Alarm Review Display*, or click on *No* to exit without acknowledging alarms.

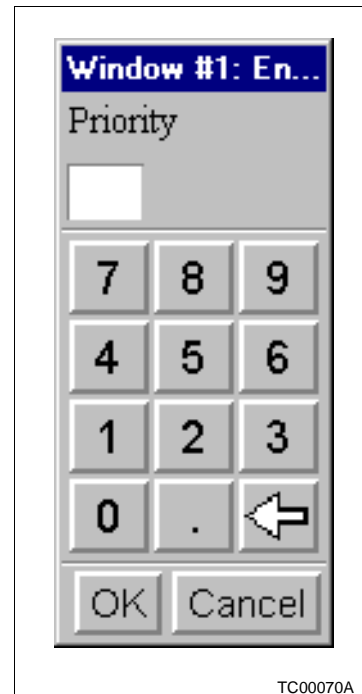

Figure 8-2. Number Entry Keypad

### Display Vectoring from the Alarm Review Display

A vector pushbutton appears to the right of each alarm acknowledge button. The face of the vector pushbutton displays the character V. Click on this button to change (vector) directly to another display.

The display which appears depends upon which display has been configured, via alarm vectoring configuration, for the point which is in alarm. If no display has been assigned, the point display for the point in alarm will appear by default. When a vector button on the alarm review display is clicked, the resulting display appears, by default, in the same window which was occupied by the alarm review.

**NOTE:** This operation differs slightly from that of the vector buttons in the mini-alarm window; clicking on a vector button in the mini-alarm window causes the resulting display to appear, by default, in the operator window which has the lowest number (i.e., Operator Window #1).

To have the target display appear in a window other than the one occupied by the alarm review, position the pointer on the desired vector pushbutton, then press and hold the left mouse button. Continue to hold the left mouse button down while dragging the pointer to a location inside the frame of the operator window which is to contain the vectored to display. When the mouse button is released, the display will be dropped into that operator window.

If the line displayed in the alarm review display changes during the drag and drop operation, the alarm vectoring configuration which was in effect when the vector button was selected will remain in effect until the operation is completed. Attempts to drop the display in anything other than an operator window (i.e., a pop-up window, the system window, and so on) will cause the PWC90 console to beep and the operation to terminate. Similarly, if the pointer is on an operator window frame (instead of inside the window or on the title bar), the system will beep and the operation will terminate.

### Filtering Alarms

Data contained in an *Alarm Review* display is automatically filtered by the filtering mask configured for the user currently logged in on the PWC90 console. The user can further filter incoming process alarms by process alarm type, priority, area and PWC90 console. To access the filtering mechanism, click on the *Filter* item which appears in the operator window menu bar of the *Alarm Review* window. The *Alarm Review Filter* (Figure 8-3) window will be displayed.

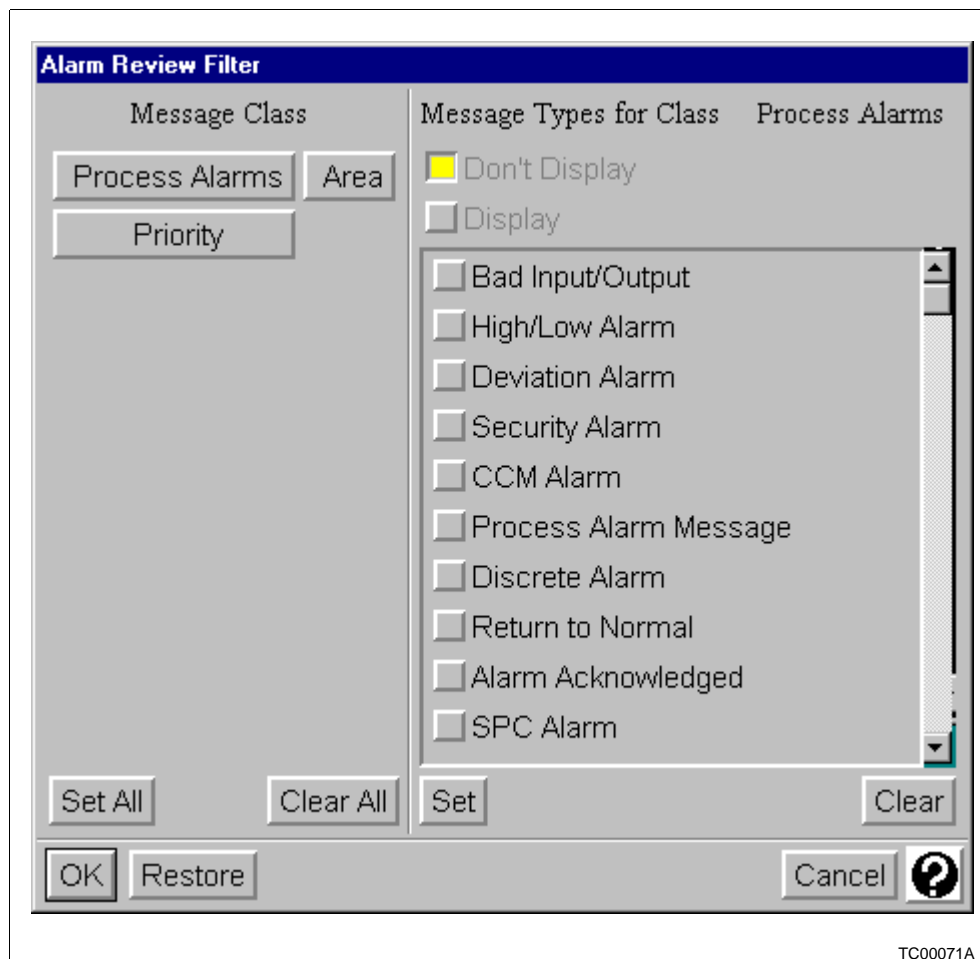

Figure 8-3. Alarm Review Filter Window

The main display area of this window is divided in two portions; the left side is labeled *Message Class*, and contains buttons which display the available message class names. The right side of the main display area contains a list box, which in turn contains a scrollable list of all the *Message Types* available for the selected message class. Click on the desired message class button to select it:

- Process alarms.
- Priority.
- Area.

When a new message class is selected, the list of message types in the list box changes to display the types available for that message class. Each message type has a pushbutton associated with it; click on this pushbutton to select or deselect the message type. If a message type is selected, messages of that type will be filtered out, and will not be displayed. If a message type is selected, the associated button will appear pressed in, while a deselected button appears to be raised. Samples of the selected and deselected states appear above the list box; the selected state is labelled *Don't Display*, while the deselected state is labelled *Display*. Note that these labels are stippled out, indicating that the sample buttons are not available for actual use.

Use the *Restore* button at the bottom of the *Alarm Review Filter* window to return to the default filtering for the current login.

---

### **MESSAGE CLASS: PROCESS ALARM MESSAGES**

Process alarm messages are displayed in both the *Alarm Review* display and the top two lines of the mini-alarm window, known as the alarm display area.

Process alarm messages are classified into the following message types:

- Bad input/output.
- High/low alarm.
- Deviation alarm.
- Security alarm
- Process alarm message.
- Discrete alarm.
- Return to normal.
- Alarm acknowledged.

Process alarm messages for bad input/output, high/low, deviation and discrete alarms are displayed in the following format:

```
<<Priority>><<Area>><<Time>><<Date>><<Tagname>><<AlarmStatus>>
<<Legend>>
```

Process alarm messages for security alarms are displayed in the following format:

```
<<Priority>><<Area>><<Time>><<Date>><<Tagname>><<AlarmStatus>>  
<<Alarm Tag>><<Legend>>
```

Process alarm messages for all other alarms are displayed in the following format:

```
<<Priority>><<Area>><<Time>><<Date>><<Message>>
```

---

#### **MESSAGE CLASS: PRIORITY**

To filter messages by priority, click on the *Priority* message class button on the *Alarm Review Filter* window (Figure 8-3). The message type area of the window will contain an entry for each available priority (1 through 16). Click on each priority for which routing is to be changed, or use the *Clear* or *Set* buttons to clear or set the routing status of all priorities.

---

#### **MESSAGE CLASS: AREA**

When the *Area* message class is selected, the list box contains a scrollable list of the 64 available areas. Select items as described in ***Alarm Review Display Acknowledgment*** in this section. If an area has been selected, alarm messages from servers in that area will not be displayed.

---

#### **CLEARING AND SETTING ALARM REVIEW MESSAGE TYPES**

It is possible to clear or set multiple message types simultaneously, eliminating the need to click on numerous toggle buttons. Click on *Set* or *Clear* to set or clear all message types in the selected message class. Click on *Set All* or *Clear All* to set or clear all message types in all message classes in the *Alarm Review* window.

---

#### **Sort Alarms in the Alarm Review**

The order in which alarm messages are displayed in the *Alarm Review* window is determined by the choices made during configuration of the PWC90 console alarm setup, described in ***Personal Work Center 90 Configuration*** instruction. The system can be configured to display either the newest or oldest alarm (with highest priority) first. Furthermore, this order can be the same or reversed if unacknowledged alarms exist.

The *Sort* option on the alarm review display menu bar is used to sort alarms based on the following parameters:

- Time order (oldest alarm first or newest alarm first).
- Process alarm type.

- Priority.
- Area.

To sort the alarms in the *Alarm Review* display, click on the *Sort* option. The *Alarm Review Sort* window (Figure 8-4) will be displayed.



Figure 8-4. *Alarm Review Sort* Window

The top of the window contains a pair of toggle buttons labelled *Oldest* and *Newest*. Click on the *Oldest* toggle button if the oldest alarm messages in the *Alarm Review* display are to be displayed first; click on the *Newest* toggle button if the most recent alarm messages are to be displayed first.

The central area of the *Alarm Review Sort* window contains a toggle button for each parameter by which the contents of the *Alarm Review* can be sorted, including *Type*, *Priority*, *Area*, *PCU*, and *PWC90* console. Click on the appropriate toggle button to select the desired sort parameter.

Once the time order and sort parameter have been selected, click on *OK* to complete the operation.

To restore the *Alarm Review* display to its initial priority/time order, click on *Clear* at the bottom of the *Alarm Review Sort* window. Click on *OK* to close the *Alarm Review Sort* window.

---

### **Freeze Alarm Review Display**

The *Alarm Review* display is a dynamic display, and is updated continuously as new messages are received. If many messages are received in rapid succession, viewing of the display can be difficult. To temporarily stop the display from updating, click on the *Freeze* option on the *Alarm Review* display menu bar. The *Display Frozen* pop-up window (Figure 8-5) will appear, and the *Alarm Review* display will remain static until the *OK* button on the pop-up window is clicked. Messages received

while the display was frozen will be added when the display is unfrozen.



Figure 8-5. Display Frozen Window

---

### Search Alarm Review Display

The *Alarm Review* display can be searched for the occurrence of a specific tagname. To do so, click on the *Search* option on the menu bar of the *Alarm Review* display. The *Tag Search* window (Figure 8-6) will be displayed.



Figure 8-6. Tag Search Window

This window contains the prompt:

*Enter tagname:*

followed by a text entry box. Click on the text entry box to gain focus on it, then enter the tagname to be located. Click on *OK* to complete the *Search* operation. When the tagname is found, the alarm for that tagname is displayed on the top line of the alarm review display. Click on *Cancel* to exit the *Tag Search* window without performing the *Search* operation.

---

## SECTION 9 - EVENTS

---

### *INTRODUCTION*

System event messages are generated when a problem or change of state is detected within the INFI 90 OPEN system. They are not generated when abnormal conditions, problems, or changes of state associated with the process which is being monitored occur. System event messages are generated from any node on the network that detects a problem or change of state which is outside of normal operation; the problem or state change can be internal to the node which reports it, or it can be external.

System event messages are displayed on the third line of the mini-alarm window and are accompanied by an audible alarm signal. A complete list of system event messages is contained in the *Event Review* display. Like other messages generated on the system, system event messages are stored in the historical database. They can be viewed on a Personal Work Center 90 (PWC90) console, or logged to a printer using the event historian subsystem (refer to **EVENT HISTORIAN** in this section). System event messages can also be logged to a printer as they occur.

---

### *SYSTEM EVENT MESSAGES IN THE MINI-ALARM WINDOW*

System event messages are displayed on the third line of the mini-alarm window.

---

### *Audible Alarm Format for Event Messages*

System event messages can be configured to be accompanied by an audible alarm which signals the arrival of an event message in the mini-alarm window. Configuration of this item is described in the **Personal Work Center 90 Configuration** instruction.

A rapid beep is used to signal the arrival of event messages. For details on whether this item has been configured on your system, consult your system administrator.

---

### *Acknowledging Event Messages in the Mini-Alarm Window*

At the far left of the system event message line in the mini-alarm window is the event acknowledge button. An *A* is displayed on the face of the button as a request for acknowledgment, indicating the alarm is unacknowledged. If the face of the button does not contain an *A*, the event message has been

acknowledged. To acknowledge a system event, click on event acknowledged.

---

### System Event Format

System event messages are displayed in the following format:

```
<<Time>><<Date>><<Node>><<Message>>
```

The information provided from left to right is:

- The time the event occurred in hours, minutes and seconds.
- The date the event occurred as day, month and year.
- The name of the node from which the event was generated.
- A message describing the event.

---

### SYSTEM EVENT REVIEW

The *Event Review* display allows the operator to view multiple system event messages in a single display; the actual number of event messages which can be seen depends on the size of the operator window in which they are displayed.

---

#### Accessing the Event Review Display

The event review display is accessed by using the pull-down menu available from the operator window menu bar *Select* option. Position the pointer on the *Select* option, and click the left mouse button. From the resulting pull-down menu, click on the *Event Review* item. The *Event Review* display will appear in the operator window (Figure 9-1).

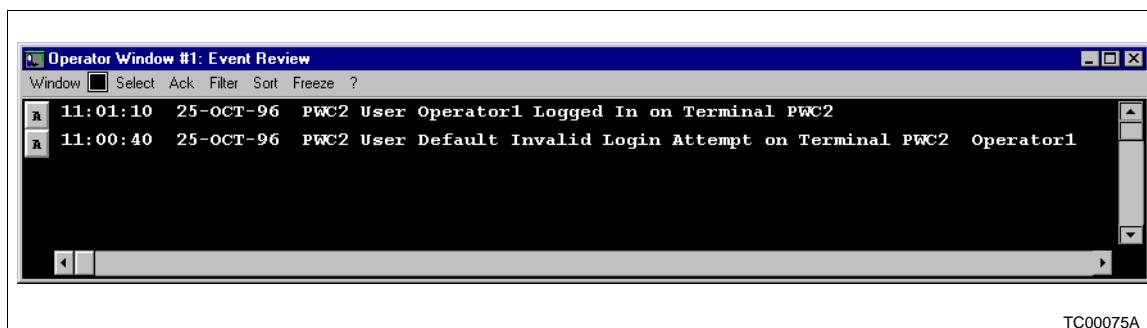

Figure 9-1. Event Review Window

The *Event Review* display is filtered to reflect the access configured for the user currently logged into the PWC90 console. A *Filter* button appears on the menu bar of the *Event Review* display.

play. The label displayed on the face of this button indicates whether alarms displayed in the *Event Review* window have been filtered. If all event messages will be displayed, the face of the button will display the word *Filter*; if some event messages will not be displayed, the label reads *Filtered*. By default, the event messages are sorted by time. Either the oldest or newest event can be first in time order, depending on the option selected when the system was configured. A quick way to see the default at a glance is to click on the *Sort* option on the *Event Review* display menu bar and view the resulting window; the *Sort* option is described in ***Sort Event Messages in the Event Review Display*** in this section.

---

### ***Event Review Display Acknowledgment***

Each line in the *Event Review* display contains data pertaining to one particular event. At the far left side of the line is the *Event Acknowledge* button. An *A* displayed on the face of the button is a request for acknowledgment, indicating the event is unacknowledged. When an event is acknowledged, it is removed from the *Event Review* display.

Event messages on the *Event Review* display can also be acknowledged using the *ACK* option on the *Event Review* menu bar. Clicking on this option causes a pull-down menu to appear. This menu is used to acknowledge multiple alarms by:

- PWC90 console.
- All Events.

Click on the desired item; a pop up window containing a text entry box and a keypad, similar to the one in Figure 9-2, will be displayed. (The label to the left of the text entry box will differ, depending on the parameter selected.)

Enter the number of the PWC90 console, etc., for which event messages are to be acknowledged. Click on *OK* to complete the operation; all event messages visible in the *Event Review* display for that PWC90 console, etc., will be acknowledged.

To acknowledge All event messages visible in the *Event Review* display, click on *All Events*, the last item in the *ACK*[nowledge] pull-down menu (or just press **Alt-F10** if the operator window containing the *Event Review* display has keyboard focus). A confirmation box will appear, which asks:

*? Acknowledge All Events on Display*

Click on *Yes* to acknowledge all events visible in the *Event Review* display, or click on *No* to exit without acknowledging event messages.

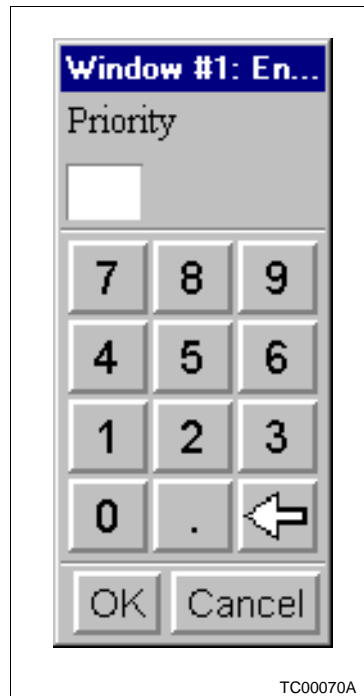

Figure 9-2. Number Entry Keypad

---

### Filtering Event Messages

Data contained in an *Event Review* display is automatically filtered by the filtering mask configured for the user currently logged in on the PWC90 console. The user can further filter incoming system event messages by system event type, PCU and PWC90 console. To access the filtering mechanism, click on the *Filter* item which appears in the operator window menu bar of the *Event Review* window. The *Event Review Filter* (Figure 9-3) window will be displayed.

The main display area of this window is divided in two main portions; the left side is labeled *Message Class*, and contains the message class *System Events*. The right side of the main display area contains a list box, which in turn contains a scrollable list of all the *Message Types* available for the selected message class. Click on the desired message class button to select it.

When a new message class is selected, the list of message types in the list box changes to display the types available for that message class. Each message type has a pushbutton associated with it; click on this pushbutton to select or deselect the message type. If a message type is selected, messages of that type will be filtered out, and will not be displayed. If a message type is selected, the associated button will appear pressed in, while a deselected button appears to be raised. Samples of the selected and deselected states appear above the list box; the selected state is labelled *Don't Display*, while the deselected

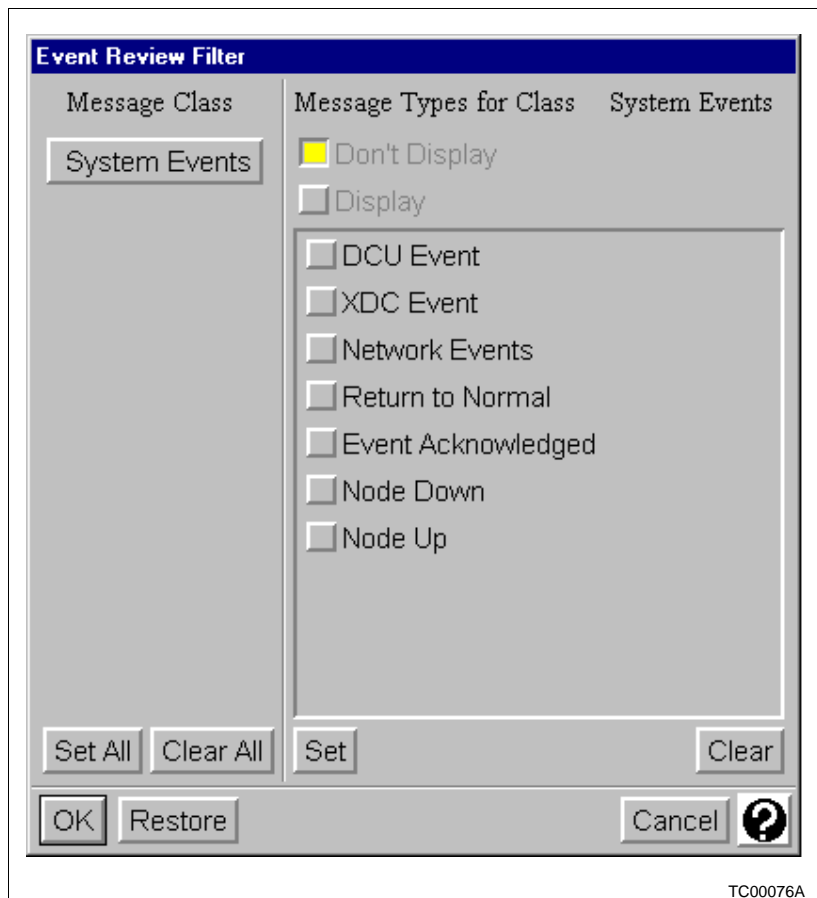

Figure 9-3. Event Review Filter Window

state is labelled *Display*. Note that these labels are stippled out, indicating that the sample buttons are not available for actual use.

### MESSAGE CLASS: SYSTEM EVENT MESSAGES

System event messages are displayed in both the *Event Review* display and the third line of the mini-alarm window, known as the event display area.

System event messages are classified into the following message types:

- PWC events.
- Network events.
- Return to normal.
- Event acknowledged.

System event messages are displayed in the following format:

<<Time>><<Date>><<Node>><<Message>>

where the node parameter indicates the node on which the message originated.

---

### **CLEARING AND SETTING EVENT REVIEW MESSAGE TYPES**

It is possible to clear or set multiple message types simultaneously. This eliminates the need to click on numerous toggle buttons. Click on *Set* or *Clear* to set or clear all message types in the selected message class. Click on *Set All* or *Clear All* to set or clear all message types in all message classes in the *Event Review* window.

---

### **Sort Event Messages in the Event Review Display**

The order in which event messages are displayed in the *Event Review* window is determined by the choices made during configuration of the PWC90 console alarm setup, described in the **Personal Work Center 90 Configuration** instruction. The system can be configured to display either the newest or oldest event first.

The *Sort* option on the *Event Review* display menu bar is used to sort event messages based on the Time order (oldest event first or newest event first).

To sort the event messages in the *Event Review* display, click on the *Sort* option. The *Event Review Sort* window (Figure 9-4) will be displayed.



Figure 9-4. *Event Review Sort* Window

The top of the window contains a pair of toggle buttons labelled *Oldest* and *Newest*. Click on the *Oldest* toggle button if the oldest alarm messages in the *Event Review* display are to be displayed first; click on the *Newest* toggle button if the most recent event messages are to be displayed first.

Once the time order has been selected, click on *OK* to complete the operation.

To restore the *Event Review* display to its initial time order, click on *Clear* at the bottom of the *Event Review Sort* window. Click on *OK* to close the *Event Review Sort* window.

---

### Freeze Event Review Display

The *Event Review* display is a dynamic display, and is updated continuously as new messages are received. If many messages are received in rapid succession, viewing of the display can be difficult. To temporarily stop the display from updating, click on the *Freeze* option on the *Event Review* display menu bar. The *Display Frozen* pop up window (Figure 9-5) will appear, and the *Event Review* display will remain static until the *OK* button on the pop up window is clicked. Messages received while the display was frozen will be added when the display is unfrozen.



Figure 9-5. Display Frozen Window

---

### EVENT HISTORIAN

Event messages which have been stored in the historical database can be displayed in the operator window. The historical database can store the last 10,000 event messages that occurred on the system.

---

#### Accessing the Event Historian

To access the event historian display, click on the *Select* item on the operator window menu bar, then click on the *Event Historian* item in the resulting pull-down menu. The event historian window (Figure 9-6) will appear.

A *Filter* button appears on the menu bar of the *Event Historian* display. The label displayed on the face of this button indicates whether alarms displayed in the *Event Historian* window have been filtered. If all event messages will be displayed, the face of the button will display the word *Filter*; if some event messages will not be displayed, the label reads *Filtered*.

The screenshot shows a window titled "Operator Window #1: Event Historian" with a menu bar containing "Window", "Select", "Filter", "Pause", "Resume", "Print", and "?". The main area displays a list of 13 events in a monospaced font. The events are listed in descending time order. The first event is at 16:04:50 on 25-OCT-96, and the last is at 16:04:49 on 25-OCT-96. The messages are of various types, including ADIGITAL and AANALOG. All events have a "Normal" priority. A scrollbar is visible on the right side of the list.

Area	Time	Date	Message ID	Priority
12 Area 10	16:04:50	25-OCT-96	ADIGITAL-2522	Normal
06 Area 2	16:04:50	25-OCT-96	AANALOG-1755	Normal
06 Area 4	16:04:49	25-OCT-96	AANALOG-1970	Normal
06 Area 4	16:04:49	25-OCT-96	AANALOG-1959	Normal
06 Area 4	16:04:49	25-OCT-96	AANALOG-1948	Normal
06 Area 4	16:04:49	25-OCT-96	AANALOG-1937	Normal
06 Area 4	16:04:49	25-OCT-96	AANALOG-1926	Normal
06 Area 4	16:04:49	25-OCT-96	AANALOG-1915	Normal
06 Area 4	16:04:49	25-OCT-96	AANALOG-1904	Normal
06 Area 3	16:04:49	25-OCT-96	AANALOG-1893	Normal
06 Area 3	16:04:49	25-OCT-96	AANALOG-1882	Normal
06 Area 3	16:04:49	25-OCT-96	AANALOG-1871	Normal
06 Area 3	16:04:49	25-OCT-96	AANALOG-1860	Normal

TC00078A

Figure 9-6. Event Historian Display

One event is shown per line and the total number of lines available is determined by the size of the operator window in which they are displayed.

Events of different classes and types in the event historian display can appear in different colors, depending on how *Message Routing* (described in the **Personal Work Center 90 Configuration** instruction) has been configured. The feature is designed to help the user locate messages of a particular class and type easily.

The events in the event historian display are shown in decreasing time order; i.e., newer events appear above older events.

### Scrolling the Event

When the *Event Historian* display contains more data than can be viewed on the screen, single and double up and down arrow pushbuttons in the scrollbar (at the right side of the event historian display) provide access to the additional data. Use these pushbuttons to view the messages which do not fit initially on the event historian display. Scroll down using the down arrows to view the older events and scroll up using the up arrows to view the newer events. Use the double arrow buttons to scroll a full page of alarms at a time; use the single arrow buttons to scroll one quarter of a page at a time.

---

### ***Pause/Resume the Event Historian***

The operating mode of the event historian display determines the behavior of the display when a new event is stored in the event historian; two modes are available:

- Update mode.
- Pause mode.

The *Event Historian* display initially appears in the update mode by default. The *Pause* and *Resume* options on the *Event Historian* menu bar are used to select the operating mode of the display. When the display is in update mode, the *Pause* option is available and the *Resume* option is stippled out. Conversely, when the display is in pause mode, the *Resume* option is available and the *Pause* option is stippled out. Pause mode is useful when reviewing older messages, to prevent them from scrolling down and off the display.

When the display is in update mode:

- *Pause* is available on the *Event Historian* display menu bar, *Resume* is stippled out.
- The event appearing on the top line is the most recent event that occurred.
- When a new event is received, it is inserted on the top line. Older messages will scroll down.

When the display is in pause mode:

- *Resume* is available on the *Event Historian* display menu bar, and *Pause* is stippled out.
- The event on the top line may not be the most recent event that occurred.
- No new events are received and displayed.

Scrolling the *Event Historian* display (by using the up and down arrows or **Pg Up** and **Pg Dn** commands) also puts the display in pause mode. Click on *Resume* to return to update mode (simply scrolling to the top of the event list does not return the printer review to update mode).

---

### ***Filtering Messages in the Event Historian***

Event messages in the event historian display are automatically filtered by the filtering mask configured for the user currently logged in on the PWC90 console. The user can further filter events by message class, message type, device and time. To access the filtering mechanism, click on the *Filter* item

which appears in the *Event Historian* display menu bar. The event historian filter window (Figure 9-7) will be displayed.

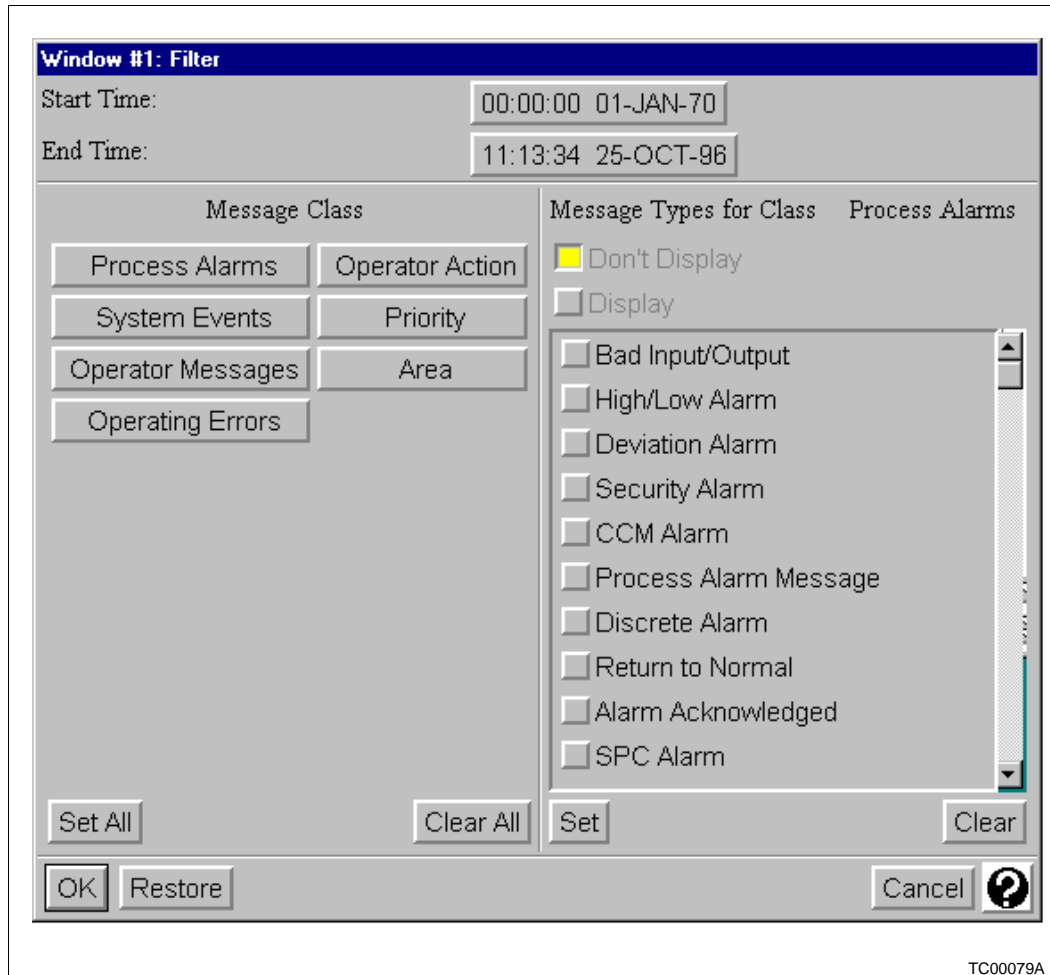

Figure 9-7. Event Historian Filter Window

### FILTERING MESSAGES BY TIME

Event messages displayed in the event historian display are shown for a specified time interval. The default time interval uses a starting time of 19:00:00 31-Dec-1969 and an ending time of the current time and date. The starting time and ending time pushbuttons are used to change the start time and end time to define the desired interval for which events are to be displayed. Click on either the *Start Time* or *End Time* pushbutton; the *Time Selection* window (Figure 9-8) will appear.

Enter the time of interest in the following format:

HH:MM:SS DD-MMM-YY

Only the parameters (i.e., hours, minutes, day, etc.) which are different from the displayed default time need to be entered.

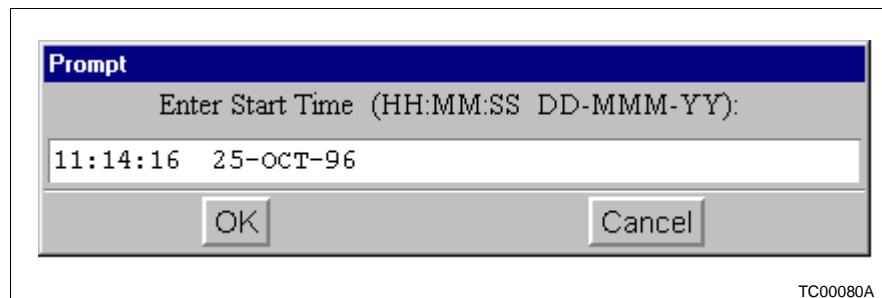

Figure 9-8. Time Selection Window

Any parameters not entered will assume the corresponding values from the default time. The exception to this is the value for seconds, which becomes zero if not specified.

For example, assume the default time shown in the *Time Selection* window is:

14:43:11 27-FEB-96

The following entries would then be interpreted as shown in Table 9-1.

Table 9-1. Event Historian Time Entries

Entry	Time
14	14:43:00 27-FEB-96
3	03:43:00 27-FEB-96
16:50:48	16:50:48 27-FEB-96
12-NOV	14:25:00 12-NOV-95

Click on *OK* to select the entered time. The *Event Historian* display is placed in pause mode. The display will scroll so that the message on the top line is the first (newest) message available with a time stamp equal to or more recent than the selected end time. The last message displayed will have a time stamp older than or equal to the start time.

Click on *OK* to complete the operation and close the *Time Selection* window, or click on *Cancel* to exit without selecting a new time.

---

### **FILTERING MESSAGES BY CLASS AND TYPE**

Messages in the *Event Historian* display can further be filtered by message class and message type. The main display area of the event historian filter window is divided into two portions; the left side is labeled *Message Class*, and contains buttons which display the available message class names. The right side of the main display area contains a list box, which in turn

contains a scrollable list of all the message types available for the selected message class.

When a new message class is selected, the list of message types in the list box changes to display the types available for that message class. Each message type has a pushbutton associated with it; click on this pushbutton to select or deselect the message type. If a message type is selected, the messages of that type will be filtered out, and will not be displayed.

---

### ***Message Class: Process Alarm Messages***

Process alarm messages are also displayed in the top two lines of the mini-alarm window, known as the alarm display area.

Process alarms are displayed in the following format:

```
<<Priority>><<Area>><<Time>><<Date>><<Tagname>><<AlarmCondition>> <<Legend>>
```

Process alarm messages are classified into the following message types:

- Bad input/output.
- High/low alarm.
- Deviation alarm.
- Security alarm.
- Process alarm message.
- Discrete alarm.
- Return to normal.
- Alarm acknowledged.

---

### ***Message Class: System Event Messages***

System event messages are also displayed in the third line of the mini-alarm window, known as the event display area.

System event messages are displayed in the format of the following example:

```
<<Time>><<Date>> INFI 90 OPEN CIU IS OFFLINE
```

System event messages are classified into the following message types:

- PWC events.
- Network events.
- Return to normal.
- Event acknowledged.

System Events can be filtered by message type.

---

### **Message Class: Operator Messages**

Operator messages are messages sent by an operator to all operators in an area, and appear in the fourth line of the mini-alarm window, as well as the *Event Historian* display.

Operator messages are displayed in the format of the following example:

```
<<Priority>><<Area>><<Time>><<Date> Water Level in Holding Tank is low.
```

Operator messages are classified into the following message types:

- Operator message.
- Message acknowledged.

Operator messages can be filtered by message type.

---

### **Message Class: Operating Errors**

Operating error messages are sent to a device designated via the message routing assignment matrix (refer to the **Personal Work Center 90 Configuration** instruction or your system administrator for details). This device can be a printer or a file.

Operating error messages are displayed in the format of the following example:

```
<<Time>><<Date>><<Device>> Insufficient Permission to Add/Remove Red Tags.
```

Operating error messages are classified into the following message type:

- Operating message.

Operating messages can be filtered.

---

### **Message Class: Operator Actions**

Operator action messages are sent to a device designated via the message routing assignment matrix (refer to the **Personal Work Center 90 Configuration** instruction or your system administrator for details). This device can be a printer or a file.

Network operator action messages are displayed in the format of the following example:

```
<<Area>><<Time>><<Date>><<Username>><<Terminal Name>> PUT  
HS-5441.C_DPV NEW=1 OLD=0
```

PWC90 console operator action messages are displayed in the format of the following example:

<<Time>><<Date>><<Username>><<Terminal Name>> graphic 1 installed

Operator action messages are classified into the following message types:

- Network operator action.
- PWC operator action.

Operating messages can be filtered.

---

#### ***Message Filter Parameter: Priority***

To filter messages by priority, click the priority message class button on the *Event Historian Filter* window (Figure 9-7). The message type area of the window will list all priorities. Click on each priority for which routing is to be changed, or use the *Clear* or *Set* buttons to clear or set the routing status of all priorities.

---

#### ***Message Filter Parameter: Area***

To filter messages by area, click the area message class button on the *Event Historian Filter* window (Figure 9-7). The message type area of the window will list all areas. Click on each area for which routing is to be changed, or use the *Clear* or *Set* buttons to clear or set the routing status of all areas.

---

#### ***Print Event Historian File***

The *Print* option on the menu bar of the *Event Historian* window allows the user to print the contents of the event historian file on demand. Click on *Print* to display the *Print Event Log* window (Figure 9-9).

The first item on the *Print Event Log* window is a pushbutton labelled *Start Time*. The time and date displayed on the face of this button indicates the earliest time and date to be used for messages included in the event log. The default starting time is 19:00:00 31-DEC-69; to change this, click the button. A pop up window appears, containing an entry box and the prompt:

*Enter Start Time (HH:MM:SS DD-MMM-YY).*

Enter the desired starting time in the indicated format. Note that the 24 hour clock is used and the month is identified by the first three letters of the month name. Click on *OK* to complete the operation, or click on *Cancel* to exit without changing the starting time.

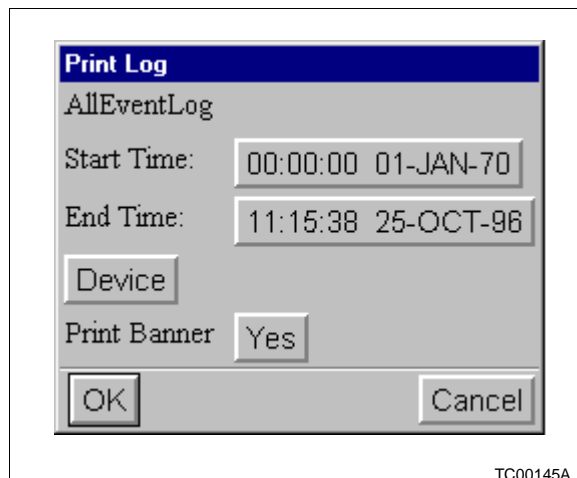
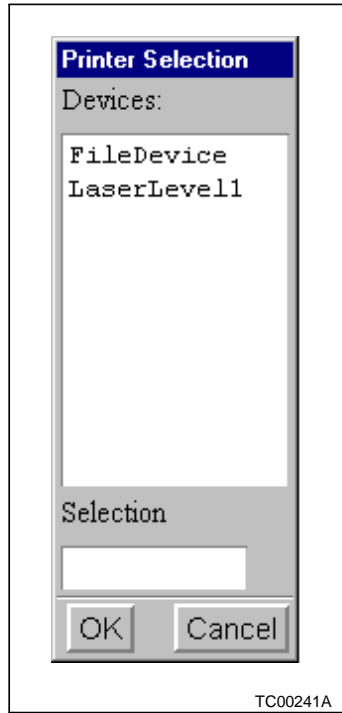

Figure 9-9. Print Event Log Window

Similarly, the second item on this window is a pushbutton labelled *End Time*. The time and date displayed on the face of this button indicates the latest time and date allowed on messages to be included in the event log. The default end time is the current time and date.

The third item on this window is a button labelled *Device*. It is used to identify the print device to which the log is to be sent. The face of the button displays the print device name, or a question mark (?) if no print device has been selected. Click on this button to configure the print device to which the log is to be printed. The *Printer Selection* window (Figure 9-10) will be displayed. Highlight the desired printer by clicking on it, then click on *OK* to complete the selection operation, or click on *Cancel* to exit without changing the device selection.

The fourth item is a pushbutton labelled *Print Banner*. The face of the associated button displays *Yes* if a banner is to be printed, or *No* if the banner is to be omitted. Click this button to toggle from one state to the other. Click on *OK* to complete the log printing operation, or click on *Cancel* to exit without changing the current selections.



*Figure 9-10. Printer Selection Window*

---

## SECTION 10 - MESSAGE REVIEW

---

### INTRODUCTION

Operator messages provide the operator with information and instruction. These messages are generated by the PWC90 console to indicate particular situations. Refer to **Message Configuration** in Section 3 of this manual for procedures to generate operator messages on the PWC90 console using message configuration.

Operator messages are displayed on the fourth line of the mini-alarm window. They can be configured to be accompanied by an audible alarm. A complete list of operator messages is contained in the *Message Review* display. Like other messages generated on the system, operator messages are stored in the historical database and can be viewed on a PWC90 console, or logged to a printer using the event historian (refer to **EVENT HISTORIAN** in Section 9). Operator messages can also be logged to a printer as they occur.

---

### MESSAGES IN THE MINI-ALARM WINDOW

Operator messages are displayed on the fourth line of the mini-alarm window.

---

#### **Audible Alarm Format for Operator Messages**

Audible alarms are used to signal the arrival of the messages as well as process alarm and event messages. Audible alarms are available in two formats on the PWC90 console:

- Steady beep.
- Rapid beep.

The rapid beep is used for messages with a high priority, while the steady beep is used for lower priority messages. The priority level which marks the division between the high and lower priority audible alarm formats can be configured, as described in the **Personal Work Center 90 Configuration** instruction. For details on the configuration of this item on your system, consult your system administrator.

---

#### **Acknowledging Messages in the Mini-Alarm Window**

At the far left of the operator message line in the mini-alarm window is the message acknowledge button. An *A* displayed on the face of the button as a request for acknowledgment, indicating the alarm is unacknowledged. If the face of the button does not contain the letter *A*, the message has been acknowl-

edged. To acknowledge an operator message, click on the event acknowledge button.

---

### Operator Message Format

Operator messages are displayed in the following format:

<Priority><Area><Time><Date><Message>

The information provided, from left to right, is:

- The priority (from 1 to 64).
- The area assigned to the operator message; users who are logged in and have access to this area will receive the message.
- The time the message was generated, in hours, minutes and seconds.
- The date the message was generated, by day, month and year.
- The message itself.

---

### MESSAGE REVIEW

The *Message Review* display allows the operator to view multiple operator messages in a single display; the actual number of messages which can be seen depends on the size of the operator window in which they are displayed.

---

### Accessing the Message Review Display

The *Message Review* display is accessed by using the pull-down menu available from the operator window menu bar *Select* option. Position the pointer on the *Select* option, and click the left mouse button. From the resulting pull-down menu, click on the *Message Review* item. The *Message Review* window (Figure 10-1) will be displayed.

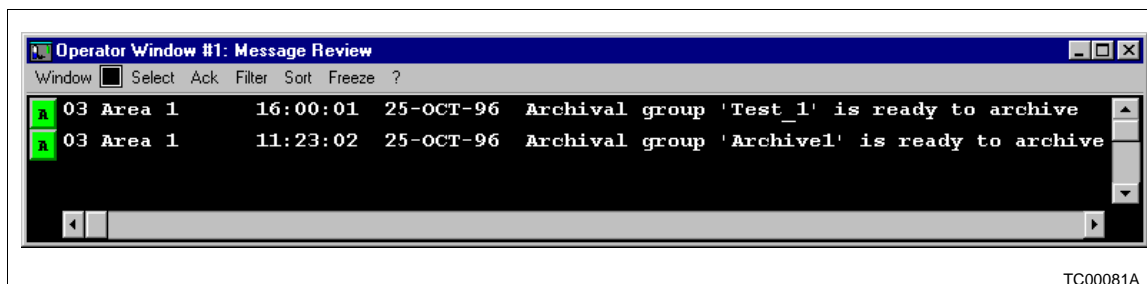

Figure 10-1. Message Review Window

The *Message Review* display is filtered to reflect the access configured for the user currently logged into the PWC90 console. A *Filter* button appears on the menu bar of the *Message Review* display. The label displayed on the face of this button indicates whether alarms displayed in the *Message Review* window have been filtered. If all messages will be displayed, the face of the button will display the word *Filter*; if some messages will not be displayed, the label reads *Filtered*. By default, the messages are sorted primarily by priority. Messages which have the same priority are further sorted by time. Either the oldest or newest message can be first in time order, depending on the option selected when the system was configured. A quick way to see the default at a glance is to click on the *Sort* option on the *Message Review* display menu bar and view the resulting display; the *Sort* option is described in **Sort Messages in the Message Review Display** in this section.

---

### **Message Review Display Acknowledgment**

Each line in the *Message Review* display contains data pertaining to one particular message. At the far left side of the line is the *Message Acknowledge* button. An *A* displayed on the face of the button is a request for acknowledgment, indicating the message is unacknowledged. If the face of the button does not contain an *A*, the message has been acknowledged.

Messages on the *Message Review* display can also be acknowledged using the *ACK* option on the *Message Review* menu bar. Clicking on this option causes a pull-down menu to appear. This menu is used to acknowledge multiple messages by:

- Priority.
- Area.
- PWC.
- All messages.

Click on the desired item; a pop up window containing a text entry box and a keypad, similar to the one in Figure 10-2, will be displayed. (The label to the left of the text entry box will differ, depending on the parameter selected).

Enter the number of the priority, area, PWC, etc., for which messages are to be acknowledged. Click on *OK* to complete the operation; all messages visible in the *Message Review* display for that priority, area, PWC, etc., will be acknowledged.

To acknowledge all messages visible in the *Message Review* display, click on *All Messages*, the last item in the *ACK* pull-down menu (or just press **Alt-F10** if the operator window containing the message review display has keyboard focus). A confirmation box will appear, which asks:

*! Acknowledge All Messages on Display.*

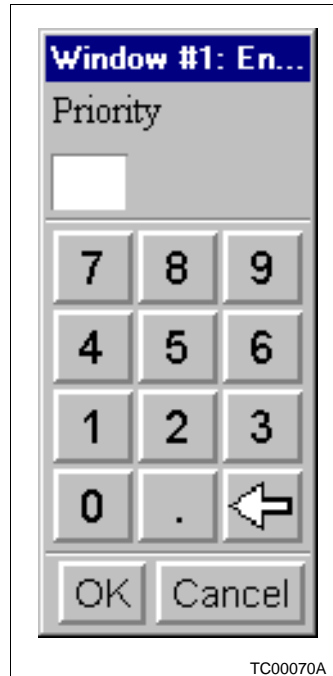

Figure 10-2. Number Entry Keypad

Click on *Yes* to acknowledge all messages visible in the *Message Review* display, or click on *No* to exit without acknowledging messages.

### Filtering Messages

Data contained in an *Message Review* display is automatically filtered by the filtering mask configured for the user currently logged in on the PWC90 console. The user can further filter incoming messages by message type, priority, area and PWC90 console. To access the filtering mechanism, click on the *Filter* item which appears in the operator window menu bar of the *Message Review* window. The *Message Review Filter* (Figure 10-3) window will be displayed.

The main display area of this window is divided in two portions; the left side is labeled *Message Class* and contains buttons which display the available message class names. The right side of the main display area contains a list box, which in turn contains a scrollable list of all the *Message Types* available for the selected message class. Click on the desired message class button to select it:

- Operator messages.
- Priority.
- Area.

When a new message class is selected, the list of message types in the list box changes to display the types available for that

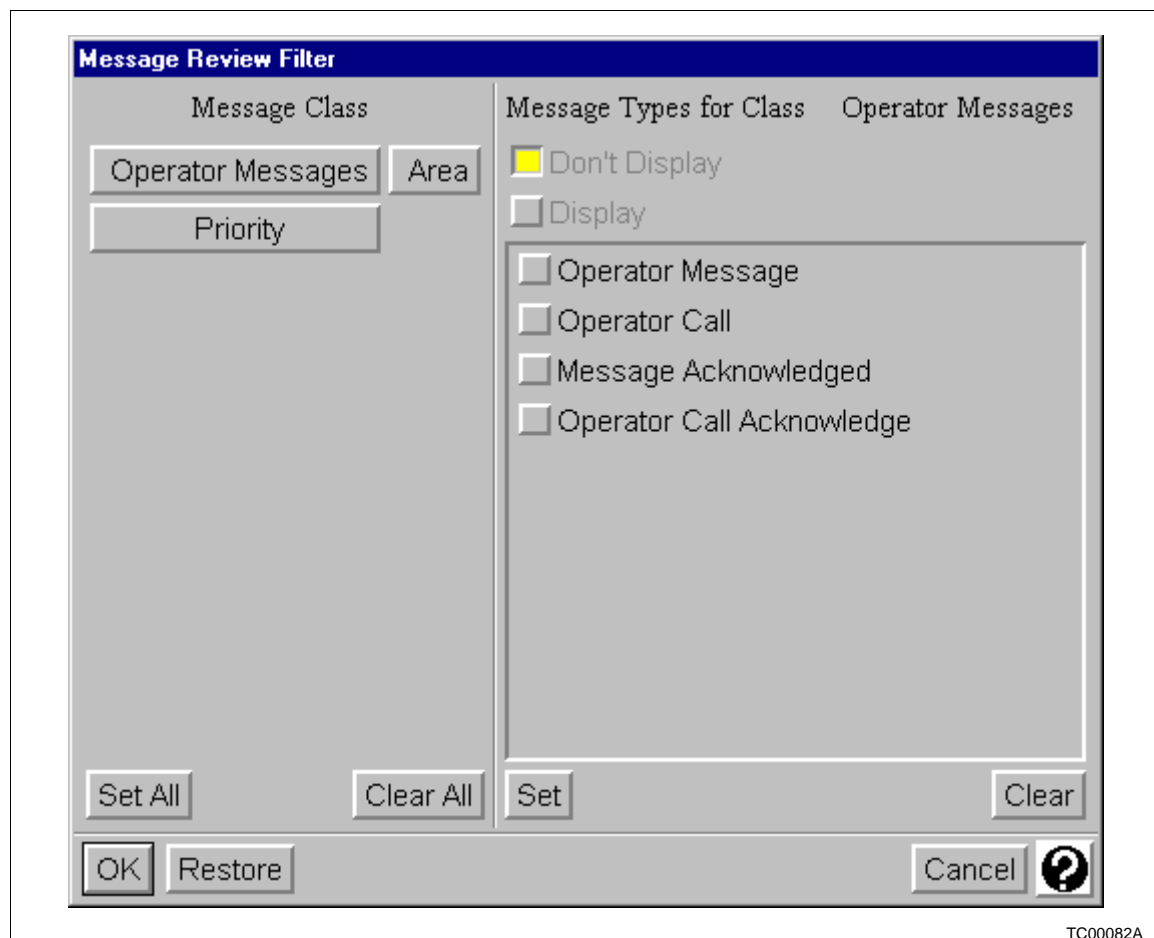

Figure 10-3. Message Review Filter Window

message class. Each message type has a pushbutton associated with it; click on this pushbutton to select or deselect the message type. If a message type is selected, messages of that type will be filtered out, and will not be displayed. If a message type is selected, the associated button will appear pressed in, while a deselected button appears to be raised. Samples of the selected and deselected states appear above the list box; the selected state is labelled *Don't Display*, while the deselected state is labelled *Display*. Note that these labels are stippled out, indicating that the sample buttons are not available for actual use.

Use the *Restore* button at the bottom of the *Message Review Filter* window to return to the default filtering for the current login.

#### **MESSAGE CLASS: OPERATOR MESSAGES**

Operator messages are displayed in both the *Message Review* display and the fourth line of the mini-alarm window, known as the message display area.

Operator message messages are classified into the following message types:

- Operator message.
- Message acknowledged.

Operator messages are displayed in the following format:

<Priority><Area><Time><Date><Tagname><Message>

---

### **MESSAGE CLASS: PRIORITY**

To filter messages by priority, click on the *Priority* message class button on the *Message Review Filter* window (Figure 10-3). The message type area of the window will contain an entry for each available priority (1 through 16). Click on each priority for which routing is to be changed, or use the *Clear* or *Set* buttons to clear or set the routing status of all priorities.

---

### **CLEARING AND SETTING MESSAGE REVIEW MESSAGE TYPES**

It is possible to clear or set multiple message types simultaneously, eliminating the need to click on numerous toggle buttons. Click on *Set* or *Clear* to set or clear all message types in the selected message class. Click on *Set All* or *Clear All* to set or clear all message types in all message classes in the *Message Review* window.

---

### **Sort Messages in the Message Review Display**

The order in which messages are displayed in the *Message Review* display is determined by the choices made during configuration of PWC90 console alarm setup, described in the **Personal Work Center 90 Configuration** instruction. The system can be configured to display either the newest or oldest (with highest priority) first. Once a message has been acknowledged, it is removed from the message review display.

The *Sort* option on the *Message Review* display menu bar is used to sort messages based on the following parameters:

- Time order (oldest message first or newest message first).
- Priority.
- Area.

To sort the messages in the *Message Review* display, click on the *Sort* option. The *Message Review Sort* window (Figure 10-4) will be displayed.

The top of the window contains a pair of radio buttons labelled *Oldest* and *Newest*. Click on the *Oldest* toggle button if the oldest operator messages in the *Message Review* display are to be



Figure 10-4. Message Review Sort Window

displayed first; click on the *Newest* toggle button if the most recent operator messages are to be displayed first.

The central area of the *Message Review Sort* window contains a toggle button for each parameter by which the contents of the *Message Review* can be sorted, including type, priority and area. Click on the appropriate toggle button to select the desired sort parameter.

Once the time order and sort parameter have been selected, click on *OK* to complete the operation.

To restore the *Message Review* display to its initial priority/time order, click on *Clear* at the bottom of the *Message Review Sort* window. Click on *OK* to close the *Message Review Sort* window.

---

### **Freeze Message Review Display**

The *Message Review* display is a dynamic display, and is updated continuously as new messages are received. If many messages are received in rapid succession, viewing of the display can be difficult. To temporarily stop the display from updating, click on the *Freeze* option on the *Message Review* display menu bar. The *Display Frozen* pop up window (Figure 10-5) will appear, and the *Message Review* display will remain static until the *OK* on the pop up window is clicked. Messages received while the display was frozen will be added when the display is unfrozen.



*Figure 10-5. Display Frozen Window*

# SECTION 11 - PWC90 UTILITIES

## INTRODUCTION

Personal Work Center 90 (PWC90) utilities provide the following maintenance and information management functions:

- Backup and restore functions.
- Archiving historical and historical block data.
- Restoring archival and archival block data.
- Database maintenance.
- Manual data entry.
- Alarm groups.
- PWC90 console screen printouts.
- Release of configuration locks.
- Other applications access.

The PWC90 console utilities are accessed via the system window *Menu*. To do so, click on the system window *Menu* button, then click on the *Utilities* option on the resulting pull-down menu. The *Utilities* menu will then be displayed (Figure 11-1).

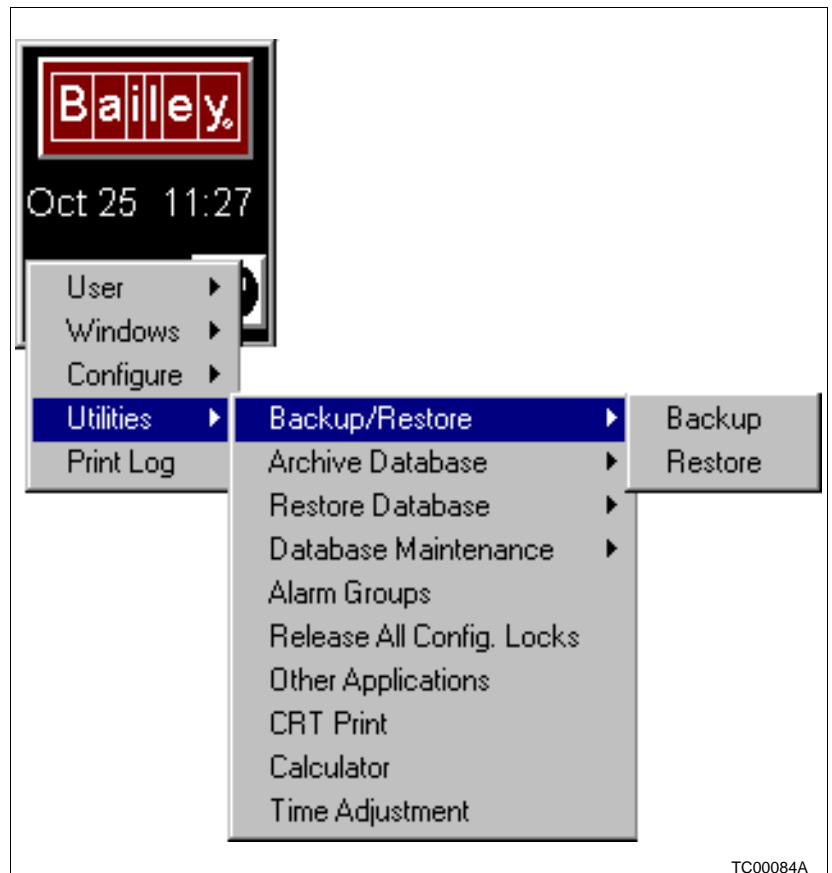

Figure 11-1. PWC90 Utilities Menu

The Windows NT accessory scientific calculator is also available from the *Utilities* menu. This on screen calculator works like a pocket scientific calculator. Instructions for its use are outside the scope of the PWC90 console Instruction.

A number of utility type features of the PWC90 console are also described here, although they are not accessed via the *Utilities* menu. These include:

- Quick keys.
- PWC90 help.
- Process help.

Some of the features documented in this section require use of removable magnetic media for backup purposes. The type of media required depends upon the hardware configuration of the system being used. Typically, backups and archives are made to tape drives, using either a DAT (Digital Audio Tape) drive or a QIC (Quarter Inch Cartridge) tape drive. Some information on use of these tape drives is provided below. A floppy disk drive is typically available as a backup device as well.

---

#### **Notes on QIC Tape Drive Use**

When inserting a QIC cartridge in a QIC tape drive, position the tape cartridge with the rectangular notch (in the metal backplate) on the left. Press the tape in the drive by pushing on the right front surface of the cartridge. Stop pushing when you feel the drive engage with the cartridge. Some quick tape drives merely require you to release the pressure on the tape to complete the loading process. Others have a latch on the front; if a latch is present, slide the latch to the right.

#### **NOTES:**

1. Never unlatch this slide while the drive light is on.
2. Never open the access hatch on the side of the cartridge. never touch the tape. follow the tape manufacturer's recommendations for tape handling and storage precautions. Each cartridge has a write protect switch on the top left side. The switch is a slotted plastic barrel with a legend such as SAFE embossed next to it. To write on the cartridge turn the slotted plastic switch so that the arrow points away from the SAFE legend.

---

#### **Notes on DAT Tape Drive Use**

When inserting a DAT cartridge in a DAT tape drive, position the tape cartridge with the hinged portion forward; typically, there is an embossed arrow on the front edge of the top of the tape. Insert the tape with the arrow pointing toward the drive. Press gently when a slight resistance is met; normally the drive

will then transport and load the tape into the drive. **Do Not Force The Tape.**

**NOTES:**

1. Never eject the tape when the tape backup light is on.
2. Never turn off the drive while the tape is running.
3. Never open the access hatch on the side of the cartridge. never touch the tape. follow the tape manufacturer's recommendations for tape handling and storage precautions.
4. Each cartridge has a write protect switch on the back edge of the cassette. slide the door open to write protect the tape; slide it closed to write enable the tape.

---

**BACKUP AND RESTORE**

Click on the *Backup/Restore* option on the PWC90 console *Utilities* menu to access a cascading menu containing the following items:

- Backup.
- Restore.

The *Backup* and *Restore* utilities are used to backup and restore user created models, server databases, spreadsheet logs, configuration reporter option sets, PWC90 console configuration data, and string files. Options are included to permit listing these files from the PWC90 console disk, as well as listing the contents of a tape.

---

**Backup Utility**

The *Backup* utility is accessed by using the pull-down menus available from the system window *Menu* button. Position the pointer on the *Menu* button, and click the left mouse button. From the resulting pull-down menu, click on the *Utilities* option, then click on *Backup* in the resulting cascading menu. The *Backup* window (Figure 11-2) will appear.

If the *Backup* display is not visible, it may be necessary to close operator windows in order to locate the *Backup/Restore* window. A backup operation copies data from the PWC90 console hard disk to a tape in the tape drive or to a disk file.

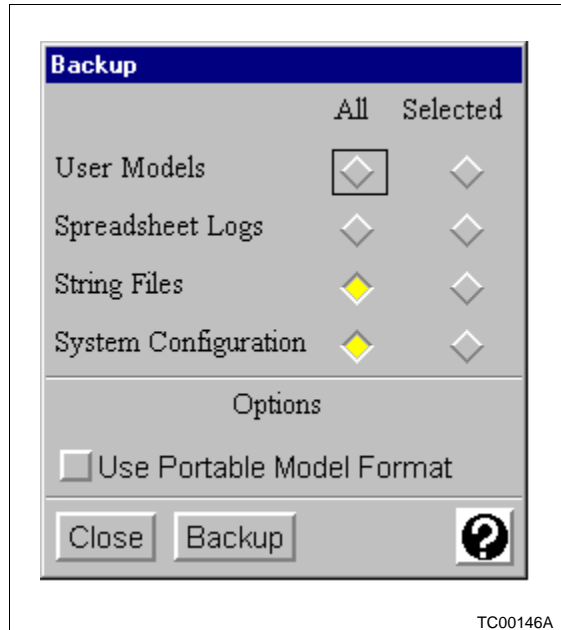

Figure 11-2. Backup Window

### BACKING UP NETWORK WIDE INFORMATION

The top portion of the *Backup* window provides the ability to backup the following types of network wide information:

- User models.
- Spreadsheet logs.
- String files.
- PWC90 console configuration data.
- INFI 90 OPEN server databases.

**NOTE:** String Files are the files containing the text which appears in the windows and on button faces, etc., on the PWC90 console displays. These files are typically used by system integrators when converting PWC90 console displays to a language other than English.

A pair of radio buttons is associated with user models, INFI 90 OPEN server databases, spreadsheet logs and string files. If the first button (labelled *All*) is selected, then all files for that information type will be backed up. To backup individual files for these information types, click the button labelled *Selected* associated with that information type; a window similar to that shown in Figure 11-6 will be displayed.

Each *Backup File Selection* window contains two list boxes. The list box on the left, labelled *Not Selected For Backup*, initially lists all the files for the selected information type. Click on an item in the list to select it, then click on *Add->* below the list box. The selected item will then be moved to the list box on the right, labelled *Selected For Backup*.

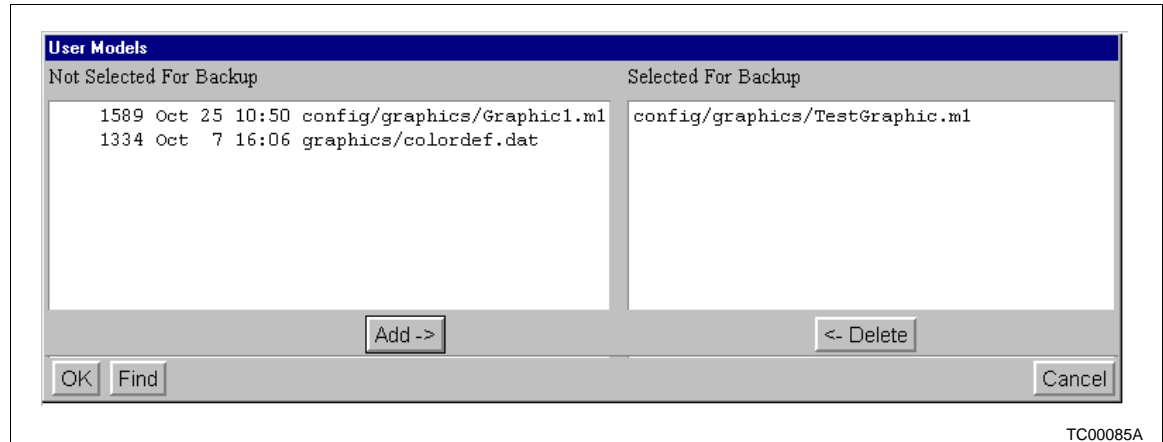

Figure 11-3. Backup File Selection Window

To remove an item from the *Selected For Backup* list box, click on the item to select it, then click on *<-Delete*. The selected item will then be returned to the *Not Selected For Backup* list box.

If only a portion of the path name for a file is known, click on *Find*. A *Find* window (Figure 11-4) will be displayed.

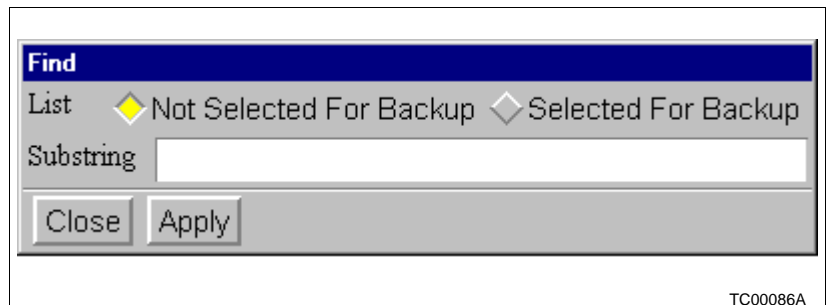

Figure 11-4. Find Window

Select the list to be searched (*Not Selected For Backup* or *Selected For Backup*), and enter the known portion of the path-name in the text entry box labelled *Substring*. Click on *Apply*; all items in the selected list which contain that string will be highlighted. (Use the scrollbars to view the portions of the list which extend beyond the viewing area of the selected list box; note that entries containing the known string are not necessarily adjacent.)

When the selected button for PWC90 console configuration data is clicked on, the *PWC90 Configuration Data* window (Figure 11-5) will be displayed.

This window allows selection of individual PWC90 console configuration topics for backup. Click on *Set All* to quickly select

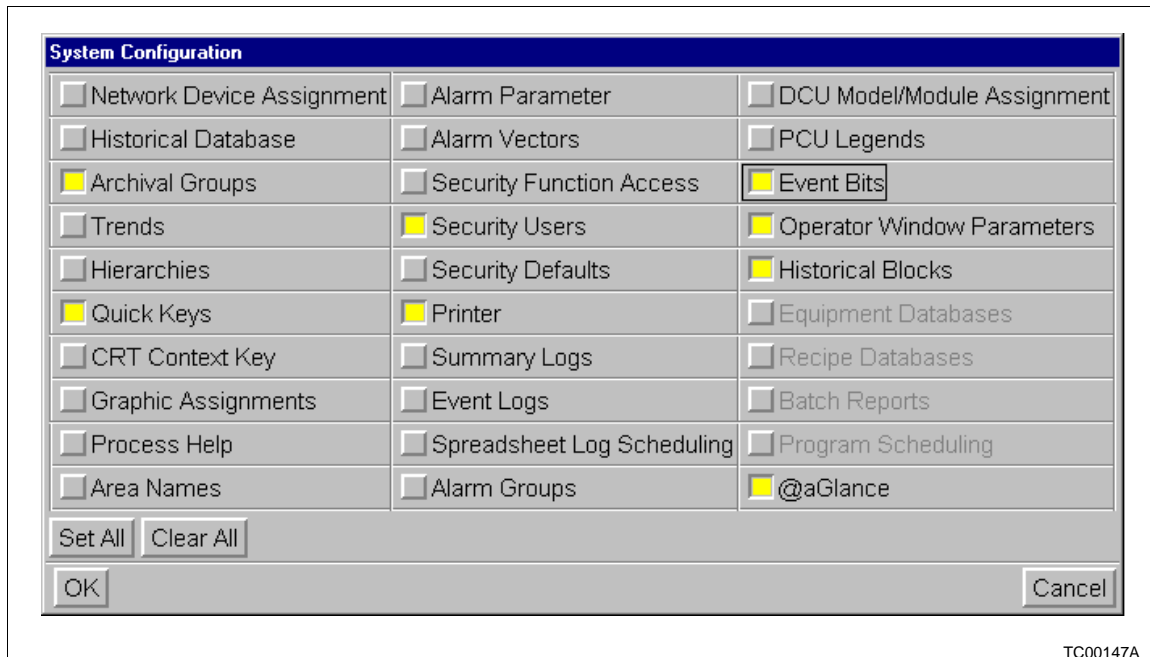

Figure 11-5. PWC90 Configuration Data Window

all PWC90 console configuration data for backup; click on *Clear All* to quickly deselect multiple items.

### **String File Considerations**

String files are the files which contain the text which appears in the windows and on button faces, etc., on the PWC90 console displays. These files are typically used by system integrators when converting PWC90 console displays to a language other than English. Files in different languages are kept in separate directories. To save space, unused string files can be deleted from the system.

Once string files have been backed up via the Backup utility, using the restore utility will cause the string files to be synchronized across the network. That is, the restored string files will be sent to all nodes on the network. Synchronization will only occur on those nodes on which the corresponding string file directory exists. Existing string files in that directory will be overwritten if they share the same file name with restored string files. (If no corresponding directory exists, it will not automatically be created.)

### **BACKING UP LOCAL APPLICATION DATA**

Local application data is data that is stored locally only on the PWC90 console on which the backup will be performed. To back up EXCEL data, the backup must be performed on the node on which the EXCEL data is stored.

Local application data that can be backed up via the backup utility includes:

- EXCEL data.

To select an item (or items) for backup, simply click the button located to the left of the item description. Buttons which appear pressed in are selected, and will be included in the backup operation.

---

### **BACKUP OPTIONS**

With the exception of user model data, data stored using the backup utility can be restored without further user action to any PWC90 console with a compatible tape drive, regardless of the hardware platform on which it resides.

To backup user model data so that it can be restored to any PWC90 console (regardless of hardware platform), the *Use Portable Model Format* option must be selected. Selection of this option provides greater flexibility when restoring data, but does cause the backup to run more slowly.

---

### **PERFORMING THE BACKUP**

When the items to be backed up have been selected, click on *Backup* at the bottom of the *Backup* window. The *Backup Operation* window (Figure 11-6) will be displayed.

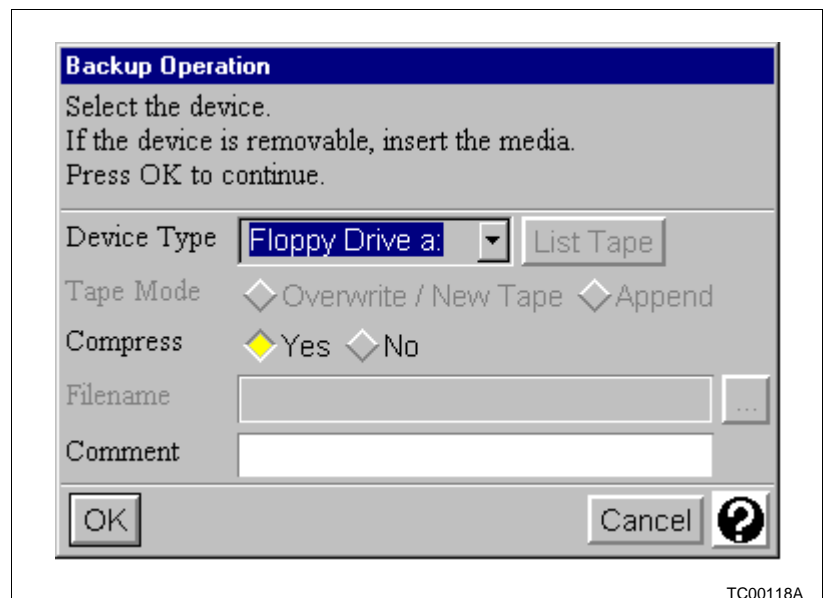

Figure 11-6. Backup Operation Window

A text box labelled *Device Type* initially displays the default backup device for the PWC90 console. Click the button which

follows it (↓) to view other available options. (If disk file or a floppy drive is selected as the device type, the *Append* option will be stippled out, and the *Filename* text entry box will become available.)

Each backup creates a volume on the tape; each volume is referred to as a file. There are two tape modes: *Append* mode and *Overwrite/new Tape* mode. The *Append* option allows multiple volumes to be appended to a single tape. (Conversely, a large volume can be continued over multiple tapes.) Note that the *Append* option cannot be used if the disk file *Device Type* or floppy drive have been selected. Do not use the *Append* option when writing to a blank tape. If the *Overwrite/new Tape* option is selected, any existing data on the tape will be overwritten. Use *Overwrite/new Tape* mode when writing to a blank tape. One of these modes must be selected in order to perform the backup. There is no default selection.

To view an index of the contents of a tape, click on *List Tape*. A *List Tape* window will be displayed. (The *List Tape* button is only available when the selected *Device Type* permits the user to append files; it cannot be used if the selected device type is disk file or a floppy drive.) Information provided in the *List Tape* window includes the file number (i.e., File 1, File 2), the backup type, the time and date of the backup, the name of the node on which the backup was performed. If a comment about the backup was entered when the backup file was created, the comment will be displayed on a second line below the file information.

A *Compress* option, selected by default, is used to compress data as it is copied to the tape; compressed data takes up less space, and allows the backup media to hold more data. Selecting the *Compress* option will allow more data to be stored in a smaller amount of space. Under some conditions (when using a DAT tape or sending the data to a disk file) use of the *Compress* option may cause the backup to run more slowly.

A *Comment* text entry box can be used to enter a description or comment which will appear as part of the entry for the backup in the *List Tape* window.

Once all selections have been made in the *Backup Operation* window, click on *OK* to begin backing up data. A backup status window, similar to Figure 11-7, provides continuously updated information as the backup progresses.

**NOTE:** The compression option will be automatically selected when necessary during a restore operation.

A *Cancel Backup* button on the *Backup Status* window provides the ability to abort the backup operation while it is running. When the backup has completed, the *Backup Status* window is

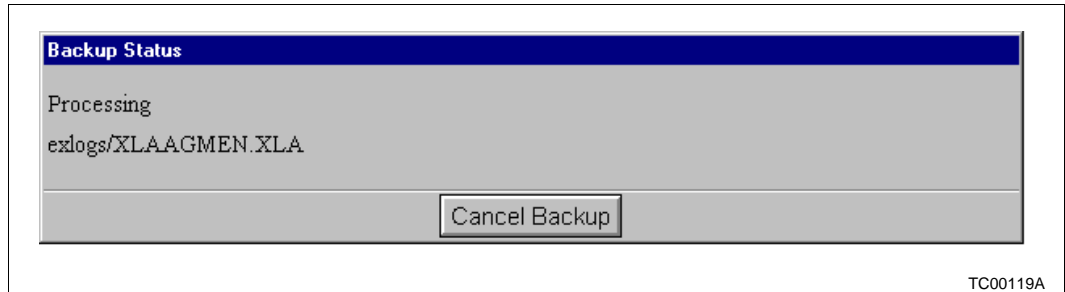

Figure 11-7. Backup Status Window

automatically closed, and a pop-up window appears to report that the backup has completed.

Click on *OK* to close the *Backup Completed* pop-up window and return to the *Backup* window. Additional volumes can be appended to the tape, if desired. Click on *Close* to exit the *Backup* window.

### Restore Utility

The *Restore* utility is accessed by using the same pull-down menus as the *Backup* utility. Position the pointer on the *Menu* button, and click the left mouse button. From the resulting pull-down menu, click on the *Utilities* option, then click on *Restore* in the resulting cascading menu. The *Restore Operation* window (Figure 11-8) will appear.

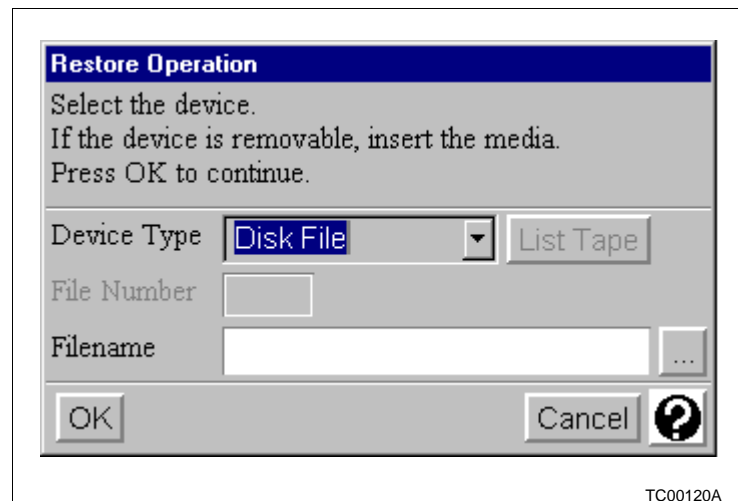

Figure 11-8. Restore Operation Window

The *Restore Operation* window has several of the characteristics found on the *Backup Operation* window, and they operate in the same manner. The *Device Type* text box initially lists the default backup device for the PWC90 console; this can be changed by clicking on the option button which follows it (↓)

and selecting a different device if this is necessary. Click on *List Tape* to view an index of files (volumes) on the tape. Note that each file has a number associated with it. The number of the file to be restored must be entered in the *File Number* text entry box on the *Restore Operation* window; no default number is provided. After the file number has been entered, click on *OK* to begin the restore operation. A confirmation box, similar to that shown in Figure 11-9, will be displayed.

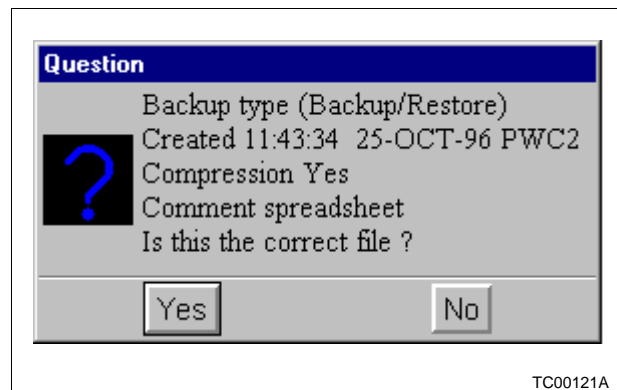

Figure 11-9. File Restore Confirmation Box

Click on *Yes* in the confirmation box to restore the selected file, or click on *No* to abort the restore operation.

If *Yes* is selected, the *Restore* window (Figure 11-10) will be displayed.

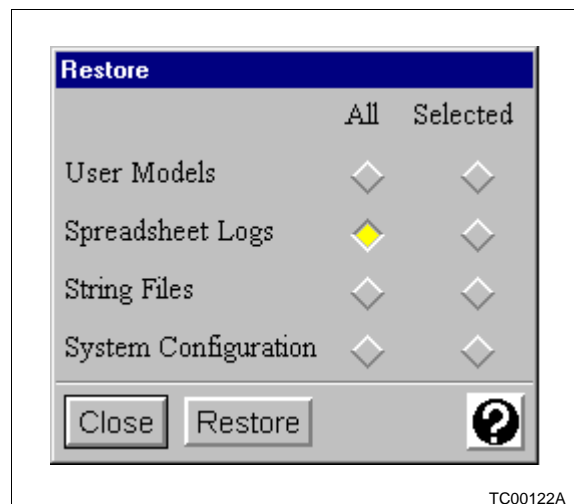

Figure 11-10. Restore Window

The *Restore* window is used to select which type of data is to be restored from the file (volume) on the tape. Only those radio buttons which represent data included in the specified file (i.e., File Number 1) can be selected; buttons which do not represent data in the specified file are insensitive, and clicking on them

will have no effect. If the *All* radio button is selected for an information type, all information for that type in the selected file will be restored. To restore only specific items, click the *Selected* radio button for that information type. A window similar to Figure 11-11 will be displayed. Click the desired files in the list to select them for restoration.

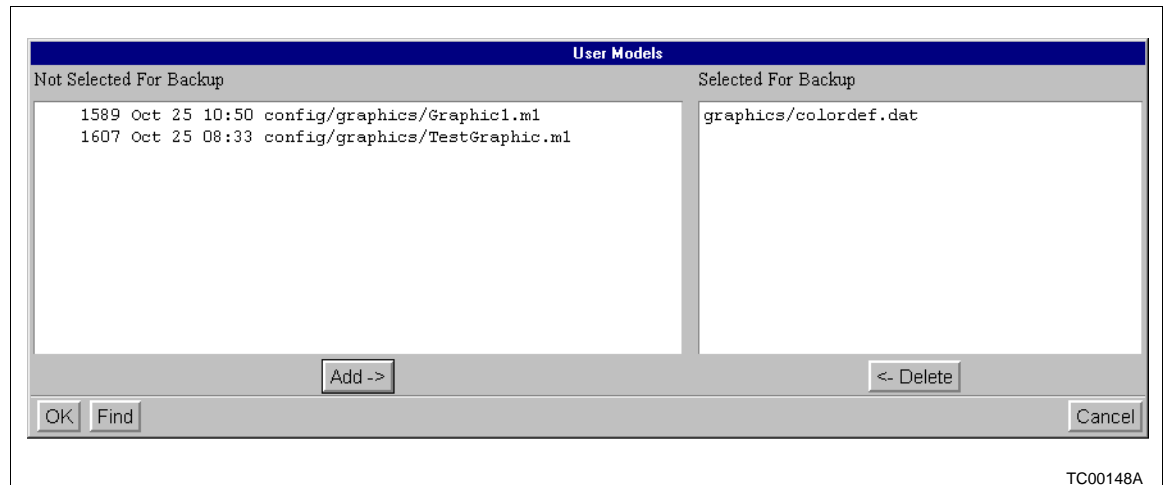

Figure 11-11. Restore File Selection Window

**NOTE:** In the case of PWC90 console configuration data, select the *All* button to restore data for all PWC90 console configuration data types. This is the equivalent of clicking on the *Selected* button, then selecting all the PWC90 console configuration data types available in the selected backup file. (If a particular data type was not included when the backup was made, then the entry for it is stippled out and it cannot be selected.)

Once all selections have been made, click on *Restore*. The *Restore File Selection* window (Figure 11-11) will be displayed. A pop-up window will be displayed when the restore operation has completed.

### LIST TAPE BUTTON

To list the contents of a tape, load the tape in the drive and click on *List Tape*. The tape will be read and a list of files on the tape will be created; when this has completed, the list will be displayed in the *Tape Listing* window.

The *Tape Listing* window contains an entry for each file on the tape, including the permissions on the file, the size of the file, the time and date the file was last written, and the path and name of the file.

**NOTE:** This operation only displays information about the data contained on the tape; no information on the tape (or the disk) is changed.

Use the scrollbars to view those file entries and portions thereof which extend beyond the viewing area. Click on *Close* to exit the *Tape Listing* window.

### LIST DISK BUTTON

Before performing a restore operation, it may be useful to compare the tape listing to a listing of the current contents of portions of the PWC90 console disk. Click on *List Disk*; a *Disk File Selection* window will be displayed (Figure 11-12).

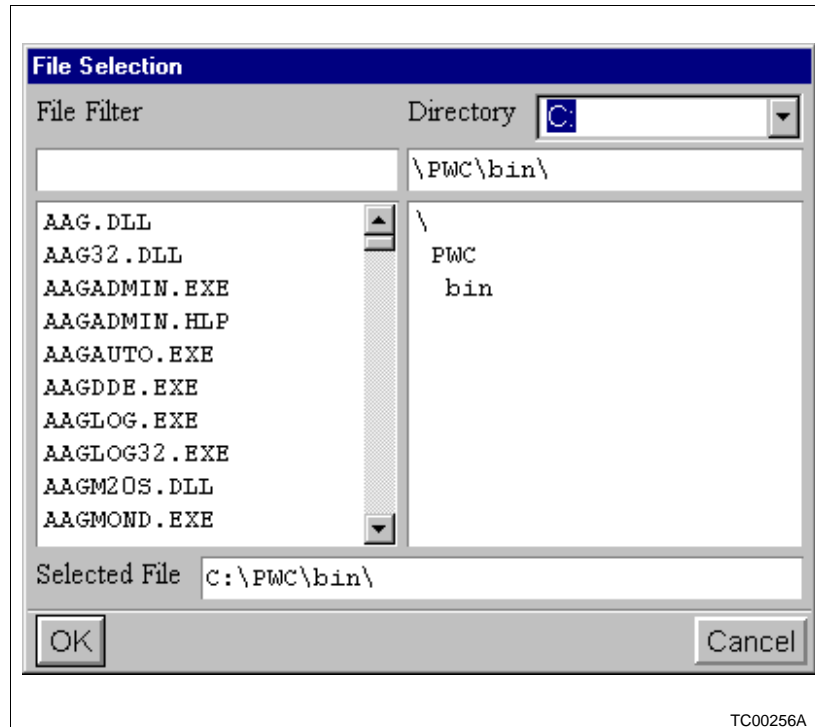

Figure 11-12. Disk File Selection window

This window allows the user to select the type of disk data files to be listed. The user can choose to list the files on the hard disk of the PWC90 console which contains:

- User models.
- Configuration data.
- Databases.
- Spreadsheet logs.

Click on the toggle button to select the associated item. The button will appear pressed in and be displayed in yellow. Once selection(s) have been made, click on *OK*; the disk listing window for that type of data file will be displayed.

The *Disk Listing* window displays information for each file in each of the selected file types, including the size, creation time and name of each file.

**NOTE:** This operation only displays information about the data contained on the disk; no information on the disk is changed.

Use the scrollbars to view those file entries and portions thereof which extend beyond the viewing area. Click on *Close* to exit the *Disk Listing* window.

---

### **RESTORE FILE BUTTON**

The *Restore File* button in the *Restore* window provides a method for restoring individual files from the tape. Click on *Restore File* to create and view a list of the files contained on the tape. If the tape contains a large number of files, a small pop-up window will appear initially, which states:

#### *Tape Listing in Progress*

This window will close as soon as creation of a list of files on the tape has been completed; a *Tape Listing* window will then be displayed.

The window lists the permissions, user ID, size, file creation (or modification) date and time, path and filename for all files on the tape. (The settings of the toggle buttons in the *Restore* window are ignored during this operation). Select each file to be restored by clicking on the corresponding line in the list. The selected file will be highlighted. If an incorrect file is selected, click on it again to deselect it. When all files to be restored have been selected, click on *Restore Selected Files* at the bottom of the *Tape Listing* window. A confirmation window listing all of the selected files will appear. Click on *OK* to restore the files, or *Cancel* to cancel the operation. If *OK* is clicked, the restore operation proceeds as described above.

A *Find* button is located at the bottom of the *Tape Listing* window, and can be used to quickly ascertain the presence of a given file (or a pathname or filename containing a given string) on the tape.

To use this feature, click on *Find*. A pop-up window titled *Find* appears, which contains an entry box, and *OK* and *Cancel* buttons. Above the entry box is the prompt:

*Enter File Name.*

Click the entry box to focus on it, then enter the string for which to search. (Although only 20 characters at a time can be viewed in the *Find* window text entry box, you can enter as many as necessary.) A path, a filename, or a portion of either

can be entered; the first entry in the list which contains the entered string will be displayed at the top of the list box.

Click on *OK* to perform the *Find* operation and close the *Find* pop-up window. Click on *Cancel* to exit without performing the *Find* operation.

---

## DATABASE MAINTENANCE

Click on the *Database Maintenance* option on the *Utilities* menu to access the cascading menu shown in Figure 11-13.

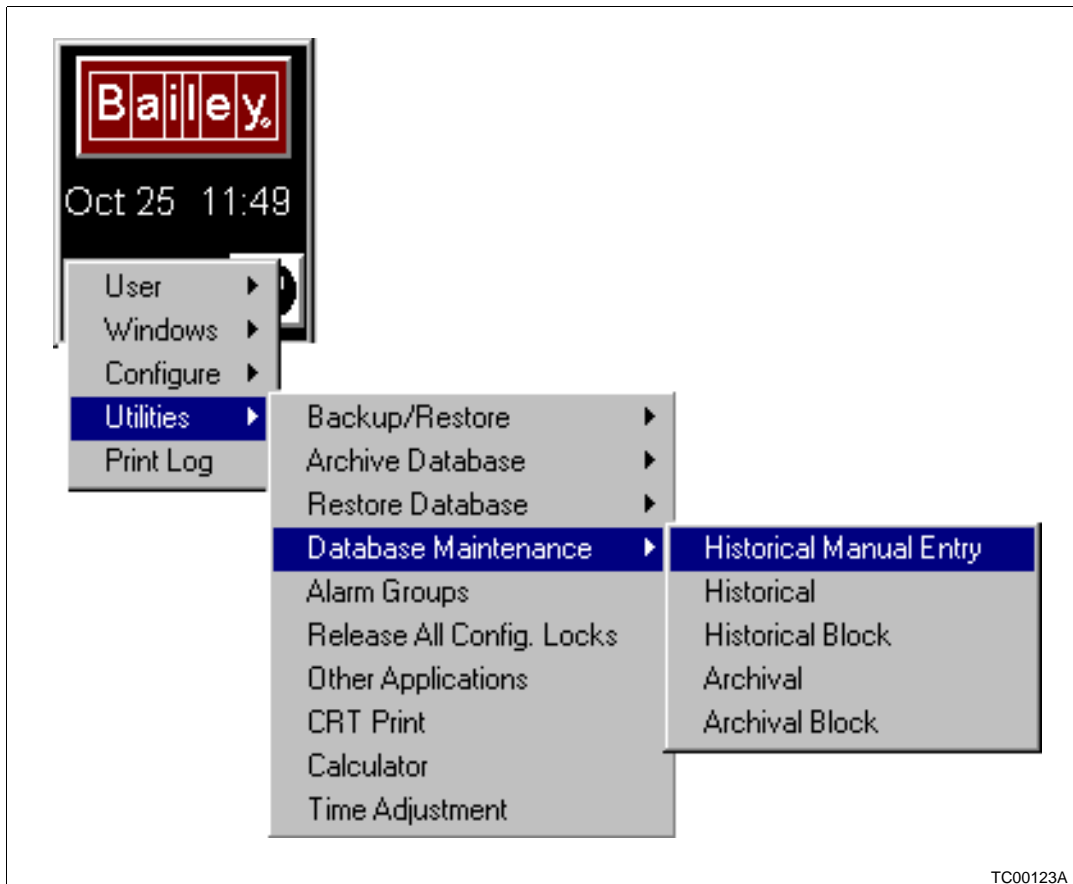

Figure 11-13. Database Maintenance Menu

The *Database Maintenance* menu is used to perform manual data entry via the *Historical Manual Entry* option and to access *Database Maintenance* windows for the *Historical*, *Historical Block*, *Archival* and *Archival Block* databases.

---

## Historical Manual Entry

This menu item is used to:

- View the values stored in the historical database for server database points (both collected values and manually entered values.)
- View the values stored in the historical database for historical database points configured with the special collection rate *Manual*; these manual data entry points were set up especially for the storage of manually entered data, such as lab results. (Configuration of manual data entry points is described in ***Personal Work Center 90 Configuration*** instruction.)
- Change or delete any values stored in the historical database.
- Enter new timestamps and data for manual data entry points.
- Enter new timestamps and data for server database collections skipped while the system was down.

Clicking on *Historical Manual Entry* in the cascading menu shown in Figure 11-13 opens the window shown in Figure 11-14.

Manual Data Entry

Tagname:  Find Prev Next

Legend:

Info:

Time:  Find Prev Next

Value:  Store Delete

OK Cancel ?

TC00124A

Figure 11-14. Manual Data Entry Window

### **VIEWING AN HISTORICAL DATABASE VALUE**

To view the value stored in the historical database for any historical database point (either a server database point or a manual data entry point) enter the name of the point in the tagname entry box in the window. There are two ways to enter a tagname in the entry box:

- Position the pointer in the tagname entry box, press the left mouse button to get the vertical bar cursor, type in the name of the historical database point, then click on *Find* to the right of the time entry box to display information about the point.

- **or** -

- Click on *Find* to the right of the tagname entry box to access another window containing an alphabetical list of all names of all historical database points. Use the *Next* and *Prev* buttons in this *Historical Tags* window to view the rest of the list. To close the window without selecting a tagname click on *Cancel* in the *Historical Tags* window. To select a tagname click on the name, then on the *OK* button. The *Historical Tags* window will close; the name of the selected point will be displayed in the tagname entry box in the *Manual Data Entry* window, and information about the point will be displayed.

The following information is displayed about the point whose tagname is entered in the tagname entry box: the point historical database legend (if configured), server tagname.atom (or *Manual* for a manual data entry point), the collection rate, and the collection option for server point (or data type for a manual data entry point.)

The timestamp of the sample in the database that was the newest at the instant that the value is displayed, and the value stored for that time will also be displayed. (The historical database for database points will continue to be updated, so newer data can be viewed after it has been collected using *Next* described below.)

To view the value with the same timestamp for the next point in the alphabetical list of historical database points click on *Next* to the right of the tagname *Find* button. If the database does not contain a value for the next point with that same timestamp, the timestamp will be displayed, but no value. A value can be inserted as described below.

To move back through the alphabetical list one tagname at a time click on *Prev* to the right of the tagname *Find* button.

To view the value for a different time for the point already in the tagname entry box:

- Move the pointer to the time entry box, press on the left mouse button to get the vertical bar cursor, and enter the timestamp of the value you want to view; then click on *Find* to display the value for that timestamp.

- **or** -

- Click on *Prev* to the right of the time *Find* button to see the previous sample (in time order) stored for the point.

- **or** -

- Click on *Next* to the right of the time *Find* button to display the next sample stored for the point.

---

### **CHANGING A HISTORICAL DATABASE VALUE**

To change the value stored for any point (either a server database point or a manual data entry point) enter the tagname in the tagname entry box or click the tagname on the tagname *Find* list. Then use one of the methods described above to display the timestamp and the value to be changed. Move the pointer to the value box, press on the left mouse button to get the vertical bar (I) cursor, and change the value. Then click on *Store* to the right of the value to save the change in the historical database. Any time a historical database value is changed manually, an event message will be generated and sent to the event historian.

---

### **ADDING AN HISTORICAL DATABASE VALUE**

To add a new time stamp and value to the database for any point (either a server point or a manual data entry point) enter the tagname in the entry box or click on the tagname in the tagname *Find* list. Then enter the new timestamp by moving the pointer to the time entry box, press the left mouse button to get the vertical bar (I) cursor, and enter the new timestamp in place of the timestamp on display. Then click in the value box and enter the new value. Finally, click on *Store* to the right of the value to save the change to the historical database.

**NOTE:** No event message is generated when a new timestamp and value are added to the historical database.

---

### **DELETING AN HISTORICAL DATABASE VALUE**

To delete a time stamp and value from the database for any point (either a server point or a manual data entry point) enter the tagname in the entry box or click on the tagname in the tagname *Find* list. Then:

- Enter the timestamp for the value to be deleted and press the time *Find* button to display the value associated with that timestamp. Once the value is on display, click on *Delete* to delete the value and its timestamp from the historical database.

- **or** -

- Use the time *Prev* and *Next* buttons until the timestamp and value to be deleted are on display, then click on *Delete* button to delete the value and its timestamp from the historical database.

**NOTE:** Deleting a timestamp and value will generate an event message.

---

### **Database Maintenance Windows**

In addition to the *Historical Manual Entry* utility, the *Database Maintenance* menu provides access to *Database Maintenance* windows for the following:

- *Historical* database.
- *Historical Block* database.
- *Archival* database.
- *Archival Block* database.

Clicking on one of these options (*Historical*, *Historical Block*, *Archival*, *Archival Block*) in the cascading menu shown in Figure 11-13 opens a *Database Maintenance* window containing read only information about disk usage for the appropriate database. This information is used by the system configure to assess memory use. Refer to **Personal Work Center 90 Configuration** instruction for information on the *Historical* and *Historical Block Database Maintenance* windows.

**NOTE:** The historical block database provides for the efficient collection of data from a large number of server tag.atoms; refer to **Personal Work Center 90 Configuration** instruction for a detailed discussion of historical block data collection. Like historical data, historical block data can be archived to tape. When data is restored from such a tape, it becomes part of the archival block database.

---

### **ARCHIVAL DATABASE MAINTENANCE**

The archival database is the storage location for historical database information restored to the system from archival tapes. The *Archival* database maintenance utility is used to display information about archival database disk usage, and to delete information from the archival database. Note that this is the only way that information is ever removed from the archival database. It is recommended that the archival database be assessed periodically to determine whether information in the archival database is still needed; if not, delete it. This will avoid wasting disk space. As the archival database expands, additional disk space will be allocated for the database. However, once allocated, space is never removed from the archival database allocation unless the *Clear Database* button is used as described below.

To use the utility click on the *Archival* option on the *Database Maintenance* menu (Figure 11-13). The *Archival Database Maintenance* window shown in Figure 11-15 will be displayed.

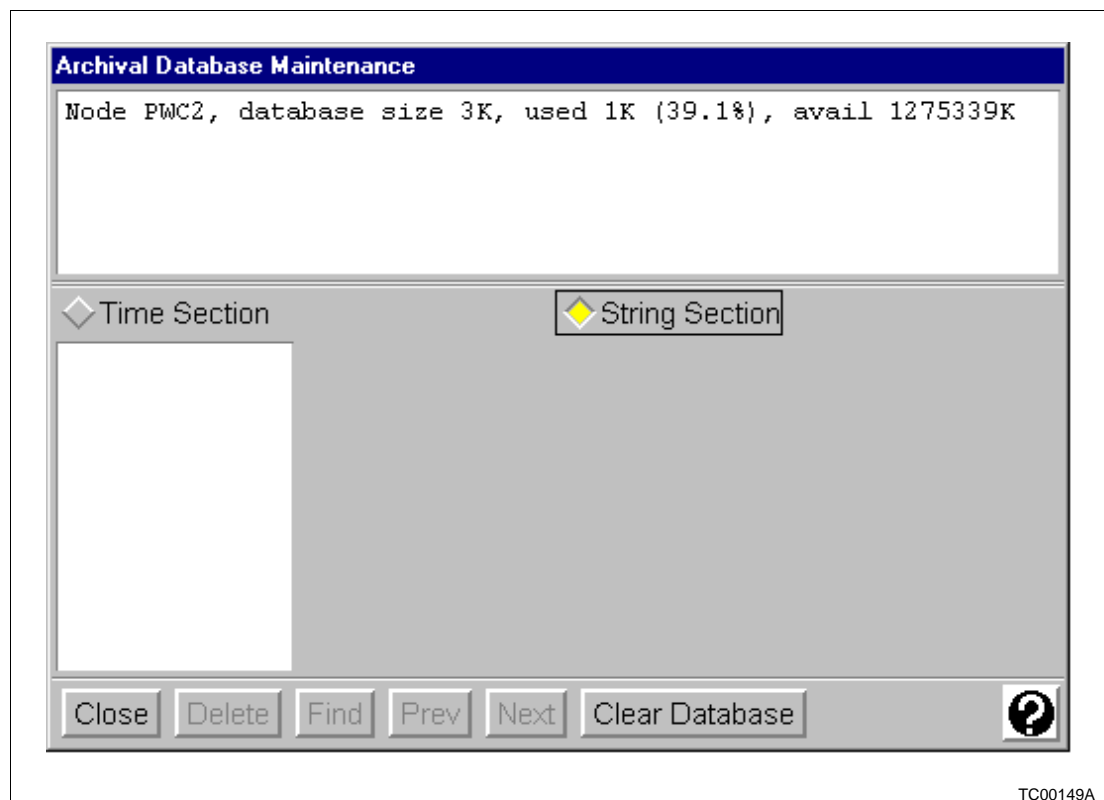

Figure 11-15. Archival Database Maintenance Window

The list box at the top of the window includes the following information:

- Node name.
- Size of the disk space allocated for the database in KB.
- Number of KB of the allocated space actually used (and the percentage).
- Total number of KB available on the node's hard drives.

Archival data is keyed (internally) by time within the archival database, so the *Time Section* radio button (below the list box containing disk usage information) should be selected. (Refer to the **Personal Work Center 90 Configuration** instruction for a more detailed discussion of the *Time Section* and *String Section* radio buttons.) This will cause the tagname of every archival database point in every archival database on the system (not just the local node) to be listed alphabetically in the tagname list box. The information displayed includes:

- Tagname preceded by an s.
- Node or nodes where the point is part of the archival database.
- Percentage of the node archival database used to store that point.

The *Archival Database Maintenance* window also contains the following buttons: *Close*, *Delete*, *Prev*, *Next*, *Find* and *Clear Database*.

---

### **Locating Specific Archival Tags**

If more archival database points have been configured than can appear in the archival tag list box, the *Prev* and *Next* buttons will become available. Click on *Next* to display the historical tags which follow those currently on display in the list box. Click on *Prev* to display the archival tags which precede those currently on display in the list box.

The *Find* button, located at the bottom of the *Archival Database Maintenance* window, can be used to ascertain the presence of a given point in the archival database. If the point does exist, the *Find* button quickly locates it in the *Archival Tag* list box and highlights it.

To use this feature, click on *Find*. A pop-up window appears, which contains an entry box, and *OK*, *Apply* and *Cancel* buttons. Click on the entry box to focus on it, then enter the desired archival tagname. If only a portion of the tagname is entered, the first entry where the first letters of the tagname match the entered string will be chosen. For example, if the string HR is entered, and the first tagname to begin with these characters is HRANo1, then this is the tagname that would be highlighted in the *Archival Tag* list box.

Click on *Apply* to locate the first instance of the string; the *Find* pop-up window will remain open; click on *Apply* again to locate the next instance of the string, or enter a new string to be located. Click on *OK* to perform the *Find* operation and close the *Find* pop-up window. Click on *Cancel* to exit without attempting to find the tagname in question, or to close the pop-up window.

---

### **Deleting Archival Data**

To delete all data for a point from the archival database on all nodes, click on the tagname to select it, then click on *Delete*. All data for that point in the local node archival database will be deleted. The space allocated for the point will not be released.

To delete all data from the archival database on all nodes and release the space allocated for it, click on *Clear Database*. A confirmation window will open containing the message:

*Database will be cleared.  
Are you sure?*

To abort the operation click on *No* in the confirmation window. To delete all the archival data stored on all nodes click on *Yes* in the confirmation window. The data will be deleted, the disk space will be deallocated and the window will close.

---

### **ARCHIVAL BLOCK DATABASE MAINTENANCE**

The archival block database is the storage location for historical block database information restored to the system from archival tapes. The archival block database maintenance utility displays information about archival block database disk usage. This information can be of value when assessing whether the block collection configuration is causing the block to use an undesirable amount of disk space.

To access archival block database maintenance click on the *Archival Block* option in the *Database Maintenance* menu shown in Figure 11-13. The features in this window are used as described in **ARCHIVAL DATABASE MAINTENANCE** for the *Archival Database Maintenance* window.

---

### **ARCHIVAL UTILITIES**

Click on the *Archive Database* option on the *Utilities* menu to access the cascading menu shown in Figure 11-16.

The historical and historical block utilities are used to archive data from the historical database and historical block database to tape cartridges. The *Restore Database* option on the *Utilities* menu is used to restore data from tape to the archival and archival block databases.

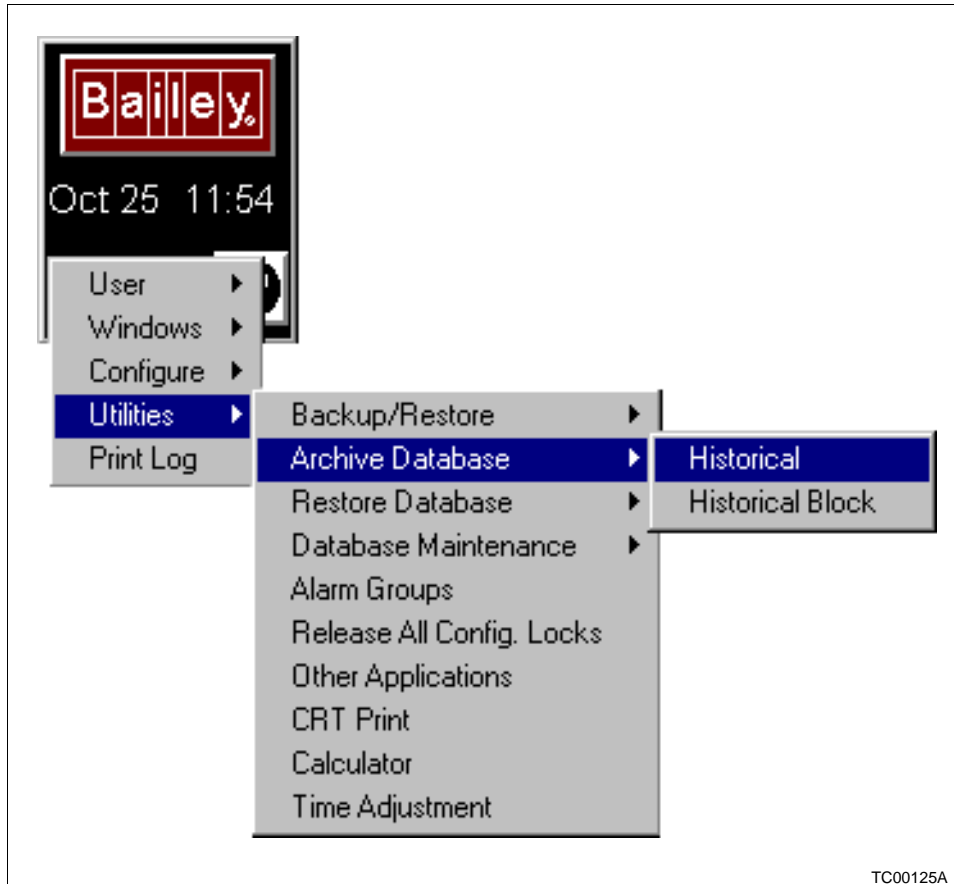

Figure 11-16. Archive Database Menu

### Archive Historical Data

The PWC90 console can be configured to collect data from a server database and place it in the historical database. Eventually, the collected data is aged out of the historical database and the disk space it occupied is overwritten by new data. Data collected in the historical database can be preserved by placing it (archiving it) onto a tape cartridge. A set of data is configured to be archived by creating and scheduling an archival group through archival group configuration as described in the **Personal Work Center 90 Configuration** instruction. Historical database points are then assigned to a configured archival group through historical database point configuration as described in the **Personal Work Center 90 Configuration** instruction. Then at the user configured cyclic interval a message will be broadcast indicating that the data for an archival group is ready to be archived. The message will be displayed on the operator message display area at the bottom of the mini-alarm window. The operator archives the data to a tape cartridge. The data will remain in the historical database only for the configured retention span. If the data is not archived to a tape before the expiration of the retention span, the data will be lost.

To archive historical data click on the *Historical* option from the *Archival Utilities* menu. The *Historical Database Archive* window shown in Figure 11-17 will open.

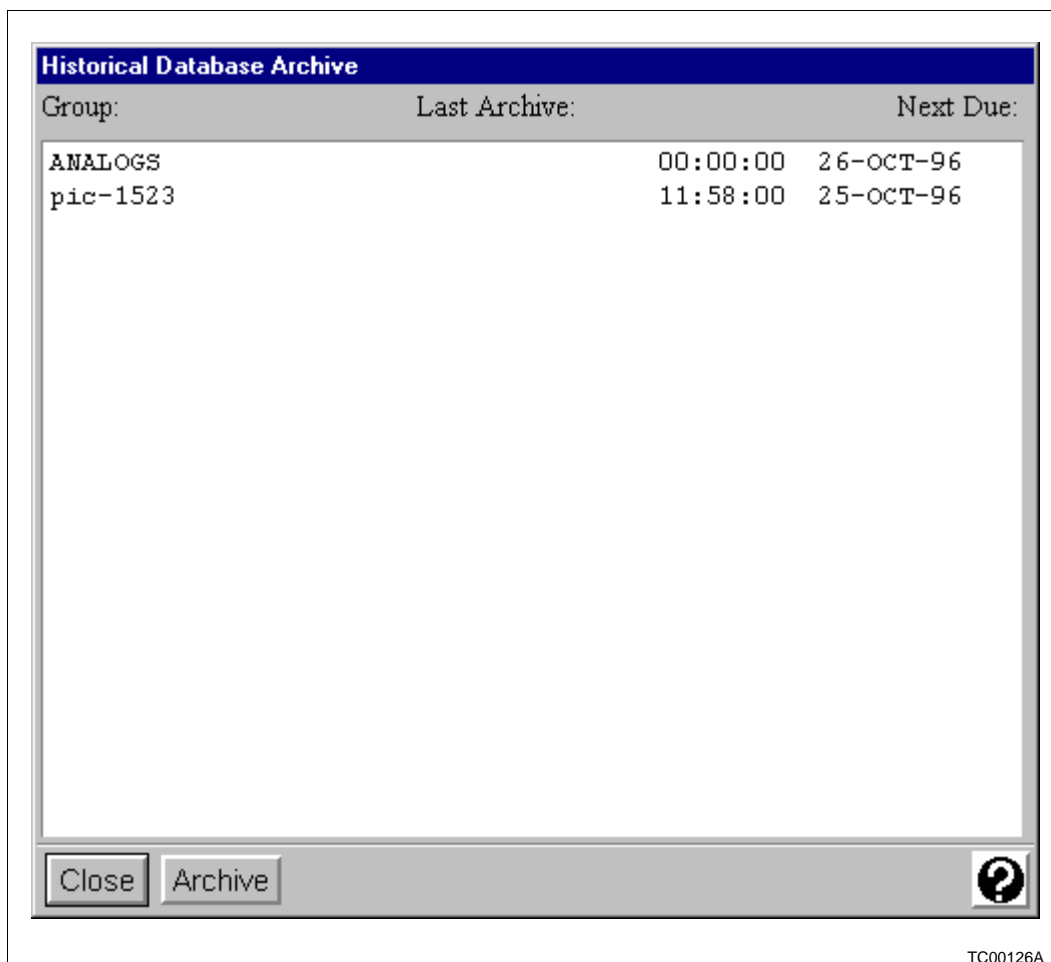

Figure 11-17. Historical Database Archive Window

This window lists the archival groups configured on the network. For each group the time of the last archival backup to tape is displayed, as well as the time the next backup is due.

The window also contains these buttons: *Close*, *Archive* and ? [Help].

To close the window without initiating a backup to tape, click on *Close*.

To initiate a backup to tape operation, select the name of the archival group to be written to tape by clicking on the name, then click on *Archive*. The window shown in Figure 11-18 will open.

The window contains a *From* entry box displaying a 0 (representing the earliest possible time and date available for data on

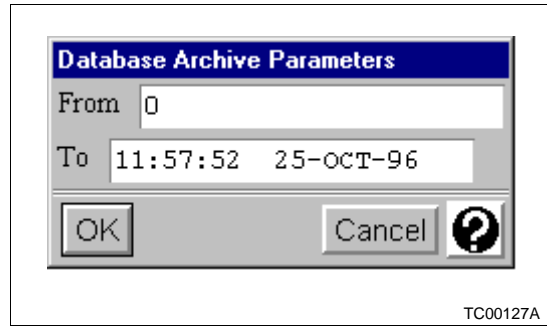

Figure 11-18. Database Archive Parameters Window

the system) and a *To* entry box with the time the backup was due already entered in the box; either the *To* or *From* time may be changed. Click on *OK* to continue, or click on *Cancel* to abort the operation.

If *OK* is clicked on, the *Backup Operation* window (Figure 11-6) will be displayed. This is the same window used with the *Backup* utility; refer to **PERFORMING THE BACKUP** in this section for information on use of this window. To initiate the backup to tape, click on *OK* after the desired items have been entered or selected.

To close the window without initiating the backup, click on *Cancel*.

When the dump has been completed, the tape light will go out and a pop-up window will be displayed which contains the message:

*Archive completed.*

Click on *OK* under the message to close the window. If the dump is not successful an error message will be displayed.

---

### Archive Historical Block Data

To archive historical block data to tape, click on the *Historical Block* item on the *Archive Database* menu (Figure 11-16). The *Historical Block Archive* window (Figure 11-19) will be displayed.

In this window is a list box which lists all the historical blocks which have been configured in the historical block database. Click on each entry which is to be archived to tape; selected entries will be highlighted. (To deselect an item, click on it a second time; the highlighting will be removed, indicating the item is no longer selected for archiving.) When all the desired entries have been selected, click on *Archive* near the bottom of the window. The *Historical Block Archive* child window (Figure 11-20) will be displayed.

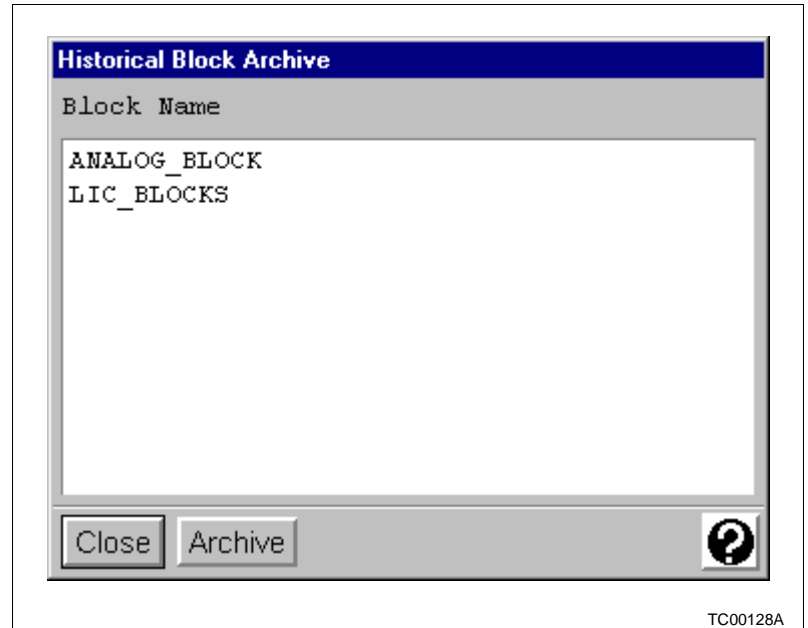

Figure 11-19. Historical Block Archive Window

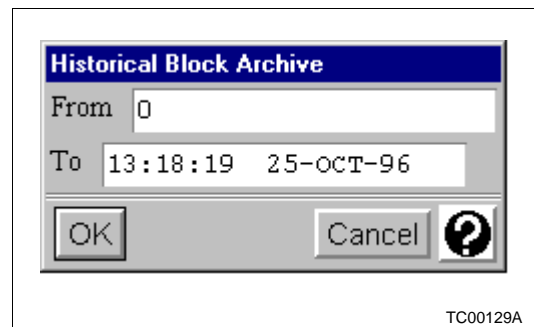

Figure 11-20. Historical Block Archive Child Window

The window contains a *From* entry box displaying a zero (representing the earliest possible time and date available for data on the system) and a *To* entry box with the time the backup was due already entered in the box; either the *To* or *From* time may be changed. When entries for these two items have been completed, click on *OK* to proceed with the archive operation. The *Backup Operation* window Figure 11-6 will be displayed. Note that this is the same window used with the archive of historical database data and with the backup utility; refer to **PERFORMING THE BACKUP** in this section for information on use of this window. To initiate the archiving of historical block data, click on *OK* after the desired items have been entered or selected.

To close the window without initiating the backup, click on *Cancel*.

When the dump has been completed, the tape light will go out and a pop-up window will be displayed which contains the message:

*Archive completed.*

Click on *OK* under the message to close the window. If the dump is not successful an error message will be displayed.

---

### Restore Archival Data

Data can be reloaded to the PWC90 console hard drive from an archival tape. Restored historical data is filed in the archival database. Once the data is in the archival database, it is accessible to trending as described in **TREND DISPLAYS** in Section 6 of this instruction.

To restore historical data to the PWC90 console hard drive from a tape, click on the *Restore Database* option on the *Utilities* menu, then click on *Archival* in the resulting cascading menu. The *Archival Database Restore* window shown in Figure 11-21 will open.

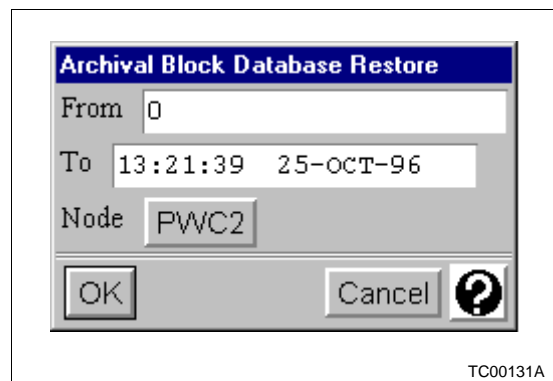

Figure 11-21. Archival Database Restore Window

This *Archival Database Restore* window contains a *From* entry box containing the default start time for the restoration, zero; this can be changed to a more recent time to do a partial restoration, instead of restoring all the data on the tape. The next item in the window is a *To* entry box with the current date and time filled in; this can also be changed. Below the *To* entry box is a *Node* button labelled with the name of the local node. To restore the data to the archival database of another node, click on *Node*. A window titled *Archive Nodes* will open listing the available archival nodes on the system. To select one of the listed nodes, click the name of the node, then on the *OK* button in the window. To close the window without changing the selected node click on *Cancel* in the *Archive Nodes* window.

To close the *Archival Database Restore* window without initiating a restoration operation, click on *Cancel*. To continue with the restore operation, click on *OK*. The *Restore Operation* window will be displayed. Note that this is the same window used with the *Restore* utility (Figure 11-8). Refer to **Restore Utility** in this section for information on using the features of this window.

To close the window without restoring archival data, click on *Cancel*. To initiate a restore operation, make all selections and/or entries in the *Restore Operation* window, put the tape containing the archived data in the tape drive, and click on *OK*. A confirmation window will be displayed.

If the backup indicated in the confirmation window is the correct one from which to restore, click on *Yes*. (To terminate the restore operation, click on *No*). If *Yes* is selected, a *Continue Prompt* window will be displayed which contains the date and node on which the archive was created, as well as the time period covered by the archive. Click on *Continue* to continue with the restore operation, or click on *No* to exit. When the dump has been completed, the tape light will go out and a pop-up window will be displayed which contains the message:

*Restore completed.*

Click on *OK* under the message to close the window. If the dump is not successful an error message will be displayed.

---

### **Restore Archival Block Data**

To restore historical block data to the PWC90 console hard drive from a tape, click on the *Restore Database* option on the *Utilities* menu, then click on *Archival Block* in the resulting cascading menu. The initial *Archival Block Database Restore* window will open.

The *Archival Block Database Restore* window contains the same features found on the *Archival Database Restore* window (Figure 11-21); these features are used as described in **Restore Archival Data**.

To close the window without initiating the backup, click on *Cancel*. To continue with the restoration of archival block data, click on *OK* after the desired start and end times have been entered. The *Restore Operation* window (Figure 11-8) will be displayed.

**NOTE:** This is the same window used with the *Restore* utility (Figure 11-8). Refer to **Restore Utility** in this section for information on using the features of this window.

---

### List Archival Block Data

To view a list of files for a specified time interval on an archival block backup tape, click on the *Restore Database* option on the *Utilities* menu, then click on *List Archival Block* in the resulting cascading menu. A *Restore Operation* window (as shown in Figure 11-8) will be displayed. Select the desired *Device Type* (refer to **Restore Archival Data** in this section). To list the Files (volumes) on the tape, click on *List Tape*. Note the number associated with the file you wish to list and close the *List Tape* window. Enter the file number in the entry box labelled *File*. Click on *OK* to complete the selection. A confirmation window will display the backup type (i.e., Block Database), creation time and date, and ask:

*Is this the correct file?*

Click on *Yes* to continue, or click on *No* to return to the *Restore Operation* window. If *Yes* is chosen, the *Block List* window will be displayed. This window lists the *Block Names* of the archival blocks on the tape.

---

### ALARM GROUPS

An alarm group is a list of tagname.atoms, each with an associated value, which are downloaded to the server database; this action is triggered by the occurrence of alarm messages which pass through a user configurable filter. This feature can be used to trigger external alarm annunciators when the downloaded values are used to change the value of control devices or output modules in the server database. See your system administrator for information on use of this feature at your site.

The *Alarm Groups* item on the *PWC90 Utilities* menu is used to manually download to a server the contents of the *On List* or *Off List* of an alarm group.

The *Alarm Groups* utility is accessed via the pull-down menus available from the system window *Menu* button. Position the pointer on the *Menu* button, and click the left mouse button. From the resulting pull-down menu, click on the *Utilities* option, then click on *Alarm Groups* in the resulting cascading menu. The *Alarm Groups Utility* window (Figure 11-22) will appear.

The main portion of the *Alarm Groups Utility* window is composed of a list box, labelled *Alarm Group Selection List*, and buttons labelled *On*, *Alarm List* and *Off*. A *Close* button and a *?* (HELP) button are located at the bottom of the display.

The *Alarm Group Selection List* is a list of all the alarm groups which have been configured on the network. Select the alarm

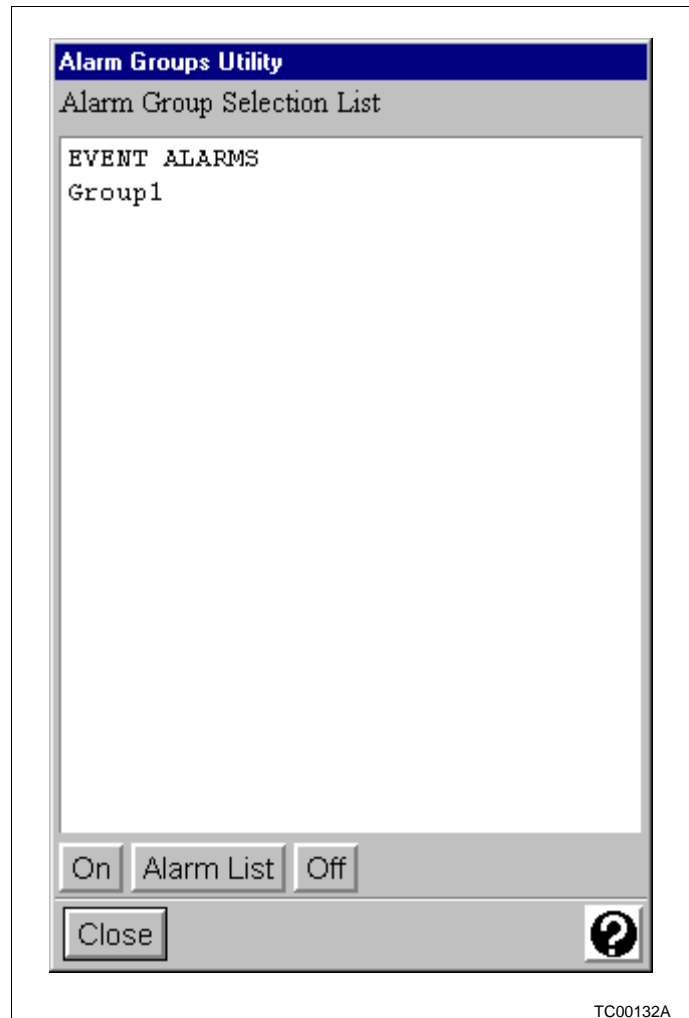

Figure 11-22. Alarm Groups Utility Window

group to be used by clicking on the name of the desired group in the *Selection List*. The selected item will be highlighted.

Each alarm group has an *On List* and an *Off List*, which can be configured; these are lists of tagname.atoms, each of which is assigned a value. The alarm group is typically configured so that the values in the *On List* are automatically downloaded to their associated tagname.atoms in the server database in response to process alarms. Similarly, the values in the *Off List* are downloaded into their respective tagname.atoms when the process alarms which triggered the download of the *On List* have been acknowledged.

**NOTE:** To view the contents of the *On* and *Off* lists for an alarm group, the user must enter alarm group configuration, which is discussed in the *Personal Work Center 90 Configuration* instruction.

The *Alarm Groups Utility* window provides a way to manually download the contents of the *On List* or *Off List* for an alarm group on demand.

To initiate a manual download of the *On List* belonging to the selected alarm group, click on *On*. A confirmation box will appear, which asks:

? Download On Values for Alarm Group <name>

Where name is the name of the selected alarm group.

Click on *Yes* to download the contents of the *On List*, or click on *No* to exit without downloading values to the server database.

To initiate a manual download of the *Off List* for the selected alarm group, click on *Off*. The resulting confirmation box asks:

? Download Off Values for Alarm Group <name>

Where name is the name of the selected alarm group.

Again, click on *Yes* to download the contents of the *Off List*, or click on *No* to exit without downloading values to the server database.

To display a list of all unacknowledged alarms, click on *Alarm List*; the *Alarm List* window (Figure 11-23) will be displayed. Information provided in this window for each unacknowledged alarm includes priority, area, time and date, tagname, alarm type, and the name of the alarm group to which it belongs. Scrollbars can be used to view information which extends beyond the window boundaries.

In addition to scrollbars, a number of features are provided on this window which allow the user to move rapidly through the entries in the list box.

Immediately below the list box is the *Find* button, with a text entry box on the right, followed by an indicator button which displays a *down* (default) or *up* arrow. Enter the text string to be located in the entry box to the right of the *Find* button. If the arrow in the directional indicator button points down (↓), then the next following instance of the string will be located and highlighted. If the arrow points up (↑), the previous instance of the string will be found and highlighted. Click the directional indicator button to toggle between the two states. After the text string has been entered and the direction chosen, click on *Find*; the next instance of the string will be highlighted in the list box. There is wrap between the beginning and end of the list box.

Click on *Top* to return to the beginning of the alarm list; use the *Bottom* button to move to the end of the list. To go to a spe-

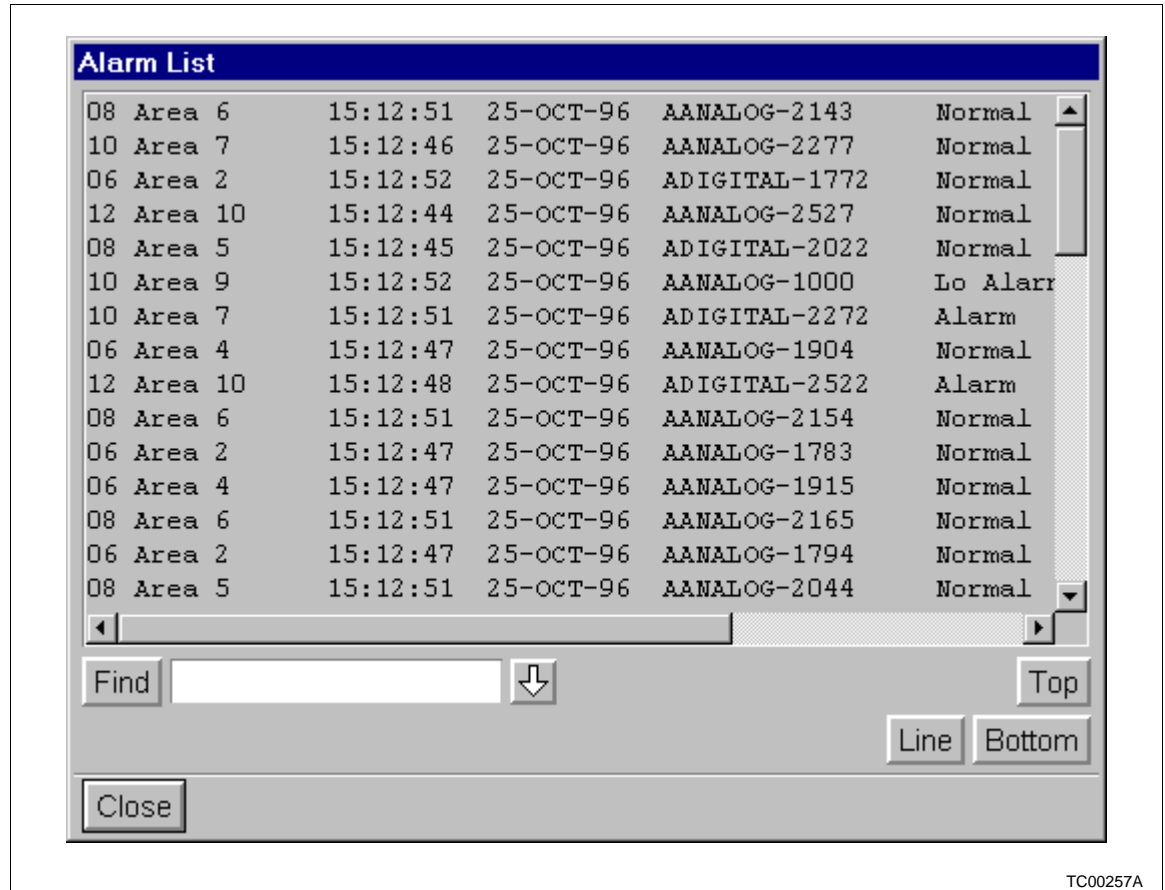

TC00257A

Figure 11-23. Alarm List Window

cific line in the list, click on *Line*; a pop-up window similar to that in Figure 11-24 will be displayed. Use the *Line* button to move within the list.

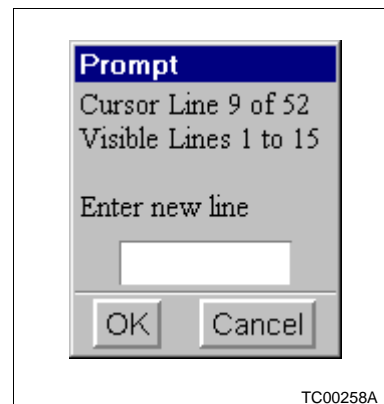

TC00258A

Figure 11-24. Line Pop-Up Window

The first item in the line pop-up window is *Current Line*, which reports the number of the line where the cursor is located, and the total number of lines in the list box. The *Visible Lines* item

reports the numbers of the first and last lines of the range which is currently displayed in the alarm list box.

A text entry box, labelled *Enter New Line*, is used to move the cursor directly to a specific line. If the line is not currently displayed in the window, the list will scroll up or down in the window until the line is visible.

**NOTE:** Line numbers are not displayed in the *Alarm List* list box.

---

## CRT PRINT

The *CRT Print* selection on the *Utilities* menu is used to print the screen content (or portions thereof) of the PWC90 console. Click on this item to display the *CRT print setup* window (Figure 11-25).

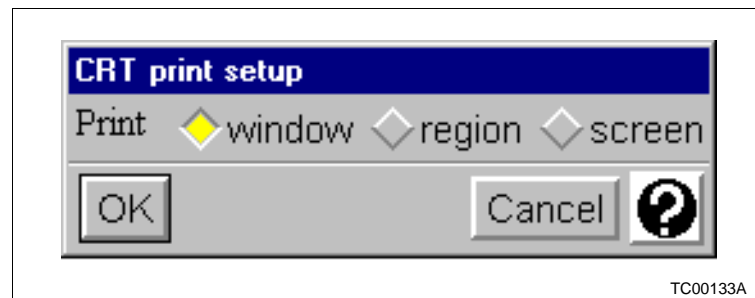

Figure 11-25. CRT Print Setup Window

---

### Selecting the Image Type

The first area of the *CRT print setup* window is labelled *Print*; this label is followed by three choices, *Window*, *Region*, and *Screen*. Each choice is preceded by a radio button; only one of these items can be selected at a time.

Click on the *Window* radio button if the image is to be defined by the borders of a selected window. Click on the *Region* radio button if the image is to be a portion of the screen. Click on the *Screen* radio button if the image is to contain the entire contents of the screen.

---

### Selecting the Printer

The second item in the *CRT print setup* window is a button labelled *Printer*. Click on this button to display the *Printer Selection* window, which contains a list of available laser and color copy printers.

---

### **Printing the Image**

After the image type and printer are set to the desired values, click on *OK*. The *CRT print setup* window will close.

If the *Screen* image type was selected, no further action is necessary. The image will be printed.

If the *Window* image type was selected, the pointer changes to a crosshair shape (✚). Move the pointer to any location within the window to be printed, then click the left mouse button. The image of the selected window will be printed.

If the *Region* image type was selected, the pointer changes to an upper left corner shape. Move the pointer to the screen location which corresponds to the upper left corner of the region to be printed, then press and hold the left mouse button. The pointer changes to a lower right corner shape. Drag the pointer to the lower right corner of the region and release the mouse button. The image of the region bounded by the selected corners will be printed.

---

### **OTHER APPLICATIONS**

The *Other Applications* option on the *Utilities* menu is used to access and run standard and (if available) custom application programs. The *Other Applications* option causes the Windows NT Program Manager window to be displayed. Consult the Microsoft Windows NT documentation for a discussion of the program manager.

---

### **RELEASE ALL CONFIGURATION LOCKS**

When certain configuration operations are in progress, software locks are set to warn other users who may attempt configuration of the same item simultaneously (i.e., user 2 attempts to configure Summary 10 when user one has already begun configuring Summary 10). This applies to the following configuration operations:

- Graphics (locked by model name).
- Summaries (locked by index number).
- Trends (locked by index number).

**NOTE:** All groups in a Summary are locked when any one group in that summary is being configured.

Security functions, including:

- Function access.
- Default configuration.
- User login.
- Security activation.

Normally a message is displayed, warning the second user that another user is already configuring an item, and providing an option to override the configuration lock.

Click on *Yes* to go ahead and override the lock, or click on *No* to exit without attempting to configure the item. Click on the question mark (?) to exit the warning window and open a window which lists the other users currently engaged in configuration of the item. The information provided about these users includes the node each is logged in on, the PWC90 console and time each commenced configuration.

If more than one user has an item open for configuration, the only changes which will take effect will be the set of changes made by the last user to save the item.

If an abnormal condition arises while a configuration operation is in progress (a PWC90 console shutdown as the result of a power failure, for example), the configuration lock will remain set when the system is recovered. The last item on the *Utilities* menu, *Release All Config. Locks*, is used to clear all such lost configuration locks. Click on this menu item to clear all locks which have been imposed on configuration on the network. Under normal conditions, use of this utility should not be necessary.

---

## **PWC90 HELP**

The PWC90 help is context sensitive help file system. When a help button is clicked in any window, the help system opens an information window describing the function of that window or related functions. After the help system has been opened it will operate similar to a Windows NT help file.

---

## **QUICK KEYS**

The PWC90 console quick keys feature provides each user with a personalized, pop-up keypad containing from 32 to 64 keys for each operator window. Each of these keys can be configured to call up a different display within an operator window. Because the set of quick keys is unique for every user, it can be customized to fit each user's individual needs.

Quick keys operate within operator windows, allowing the user to call up a specific preconfigured display by clicking on a single button. This can save a significant number of keystrokes, and is ideal for use with frequently viewed displays. By default, the parent operator window is the recipient of the new display, although drag and drop operation can be used to cause the display to appear in a different operator window. Alternatively, the same quick keys keypad can be displayed simultaneously in all operator windows on the screen. The quick keys keypad(s) can remain on display indefinitely, and can be used as

often as desired to view the various displays available via quick key assignments. The keypad(s) can be moved and resized to suit the needs of the user and the size of the parent window.

---

### Accessing the Quick Keys Feature

To access the quick keys feature, the user must be in an operator window with keyboard focus. The quick keys pop-up keypad can be summoned using either the mouse or **F5** on the keyboard. Using the mouse, click on *Select* on the menu bar of the window. From the resulting cascading menu, select the *Quick* option.

Selecting the *Quick* option will cause a pop-up window to appear, similar to that shown in Figure 11-26. Note that the information in the title bar of the pop-up window reflects the number of the parent window.

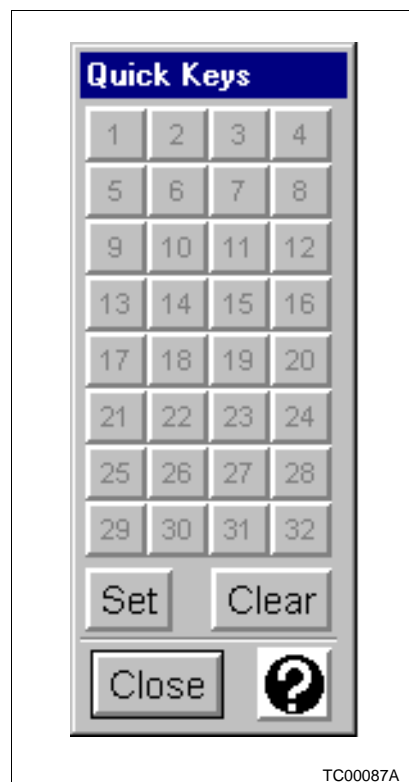

Figure 11-26. Default Quick Keys Keypad Display

If quick keys have been configured, position the pointer on the desired quick key, and click the left mouse button. The display assigned to that quick key will be displayed by default in the operator window which is parent to the quick key keypad. To have the display appear in an operator window other than the parent window, position the pointer on the desired quick key, then press and hold the left mouse button down, while dragging the pointer to a location inside the frame of the operator

window which is to contain the display. When the mouse button is released, the display will be dropped into that operator window.

**NOTE:** A minimum of 32 quick keys are displayed. If more than 32 quick keys have been configured, the quick key with the highest number is the last quick key on the display. Unconfigured quick keys between one and the highest number quick key are unavailable for use at this time, and will appear with stippled identifying numbers.

Quick keys can also be selected via the keyboard. To do so, the Quick key pop-up window must have keyboard focus. A quick key can then be selected by using the arrow keys to highlight (move black border to) the desired key; press **Return** to complete the selection.

To remove the quick key keypad from the display, position the pointer on the *Close* button, and click the left mouse button.

---

### Configuring Quick Keys

To configure quick keys, the user must be in an operator window with keyboard focus. In this window, call up the display which is to be assigned to a quick key. Click on *Set*; stippling now appears on previously assigned quick keys, protecting them from accidental re-assignment; all other quick keys are available for assignment. The pointer assumes the shape of a plus sign (+). Click the quick key which is to be used to call up the display which appears in the operator window. A new pop-up window is displayed, as shown in Figure 11-27.



Figure 11-27. Quick Key Label Assignment Window

This window allows the user to enter a text string of up to six characters in length. This text will appear on the quick key. The default text string is the number of the quick key (1 to 64); the user can choose to discard this numeric identifier. By using mnemonic identifiers and identifying the quick keys in this manner, the user can see how keys are assigned. For an example, Figure 11-28.

To exit *Set* mode without making an assignment, click on *Set* a second time; the quick keys keypad will remain on display, allowing the user to use or make further changes to the quick keys.

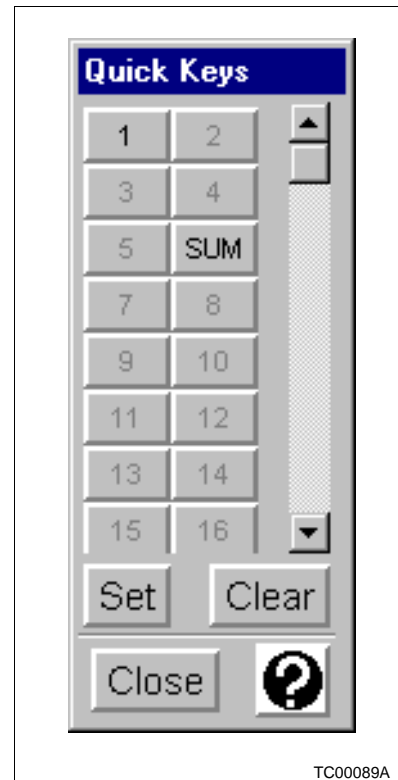

Figure 11-28. Quick Key Pop-Up

Once a quick key assignment has been made, the user need only access the quick keys keypad display and press the assigned quick key to call up that display in any operator window with keyboard focus.

### Configuring Quick Keys 33 Through 64

The basic quick key pop-up window contains a minimum of 32 buttons by default. Once all 32 buttons have been assigned, an additional 32 buttons can be configured, one at a time, for a total of 64 quick keys. When quick keys which will appear outside the current quick key pop-up (i.e., Quick Key 33) are configured, scroll bars appear on the quick key pop-up window. Use the scroll bars to view the newly created quick keys. After the quick key pop-up has been closed, then re-opened, all configured quick keys will be included in the display. The size and shape of the quick keys pop-up window can be changed using the resize handles on the window frame.

If more than 32 quick keys have been configured, and any of them have been cleared, no new quick keys will be created

until assignments for all the existing ones have been configured. For example, if 40 quick keys are assigned, then quick keys 25 through 30 are cleared, all 40 will remain on display, but new assignments must be configured for quick keys 25 through 30 before quick key 41 becomes available.

---

### **Clearing Quick Key Assignments**

Once a quick key has been assigned to a display, it cannot be reassigned to a different display until it has been cleared. To clear a quick key click on *Clear*, then click the quick key which is to be cleared. The cleared quick key will then be available for assignment to a different display. To exit *Clear* mode without clearing a quick key, click on *Clear* again; the quick keys keypad will remain on display, allowing the user to use or make further changes to the quick keys.

---

### **Exiting Quick Keys**

To exit quick keys and remove the keypad from the display, click on *Close*.

---

### **Summary - Quick Keys**

- Quick Keys** The *Quick Keys* selection offers each user a personalized set of 32 to 64 keys, each of which can be assigned to call up a different display in the active operator window. This saves time and keystrokes, and is ideal for accessing frequently viewed displays.
- Close** The *Close* button on the quick keys keypad display is used to remove the keypad display from view.
- Clear** The *Clear* button on the quick keys keypad display is used to clear quick key assignments. To do so, first click on *Clear*. Next, click the quick key to be cleared. The previous display assigned to the key will be cleared, and the key is then available for re-assignment.
- Help** The *Help* icon on the quick keys keypad display provides a description of the quick keys feature.
- Set** The *Set* button on the quick keys keypad display is used to make unused quick keys available for assignment. To do so, click on *Set*. Quick keys which have already been assigned are unavailable, and are stippled out. Click on the desired quick key, then enter a label, if desired, in the resulting pop-up window. Click on *OK* or press **Return** to complete the operation. The chosen quick key is then assigned to call up the display currently in the operator window.

---

## CRT CONTEXT KEYS

Each user can set up a personalized working environment or context, which can include multiple operator windows and their contents, as well as the size and position of quick key keypads associated with the operator windows. Different users have different contexts, depending on their area and responsibilities, and each user may have a number of different contexts which are used repeatedly. Using the on screen CRT context keypad saves time and effort by bypassing the numerous keystrokes necessary to open multiple operator windows and call up the appropriate displays.

---

### ***Preparing the Context***

The size, location and contents of each operator window on a screen can be stored and assigned to a CRT context key. In order to assign this information, the user must first set up the working environment on a PWC90 console. For example, a user might have two windows open on a screen: one in which a sequence is being controlled and one containing an associated graphic. By assigning this set of displays to a CRT context key, the user can return to this screen environment with ease by selecting the appropriate CRT context key.

---

### ***Initial Display Layout - Login Context Key***

The login context key is assigned as the user's initial display layout, which appears automatically each time the user logs in. If a user has no context assigned to the login context key, the previous contents of the screen remain after the user logs in. In the case of the *Default User* state (no user logged in) the initial display layout consists of one operator window containing the system status display. The user can change the contents of this window and/or increase the number of windows in the *Default User* initial layout; clearing this layout will always cause it to return to the single operator window/system status display combination.

---

### ***Accessing CRT Context Keys***

CRT context keys allow each user to save up to 17 working contexts (the login context key plus 16 additional keys) and assign each context to one individual key which appears on the screen. To access the CRT context keys option, first click the system window *Menu* button, then click the *Windows* option on the resulting pull-down menu. A second menu will cascade from the first, containing the *CRT Context Keys* option. Click the *CRT Context Keys* option; a window known as the *CRT Context Keys* keypad will be displayed. This window contains the set of CRT context keys available in the current user's login configuration (Figure 11-29).



Figure 11-29. CRT Context Keys Keypad

### Configuring CRT Context Keys

When the *CRT Context Keys* keypad is first called up, any CRT context keys which have not been assigned appear stippled, because they are not yet available to the user. Normal alphanumeric text appears on any *CRT Context Keys* which have been assigned a context.

The *Set* button allows the user to assign the displays that are currently on the screen to any one of the CRT context keys. (Any pop-up windows which are present are ignored.)

Position the pointer on the *Set* button and click the left mouse button. CRT context keys which have already been assigned now appear stippled, and unassigned keys are available. Position the pointer on the key to be assigned, and click the left mouse button. A pop-up window will be displayed, as shown in Figure 11-30.

To exit set mode without making an assignment, click on *Set* a second time.

The user can enter a text string of up to eight alphanumeric characters, which will appear on the key. The key number is the default string, and can be changed by the user. Click on *OK* to complete the selection procedure, or click on *Cancel* to exit without making changes.

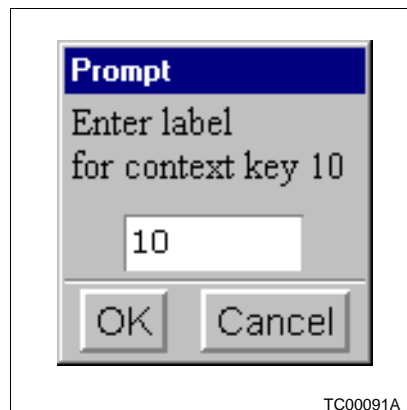

Figure 11-30. CRT Context Key Assignment Window

---

### Clearing CRT Context Keys

CRT context keys must be cleared before reassignments are made. To clear a CRT context key, click on *Clear*. Click on the CRT context key which is to be cleared. All CRT context assignments associated with that key will be destroyed, and the key is available for a new assignment.

To exit *Clear* mode without clearing an assignment, click on *Clear* a second time.

---

### Exiting CRT Context Keys

The CRT context keys keypad will remain on the screen until the user clicks on *Close*. If the user elects to have this display remain on the screen, the CRT context keys keypad can be moved to a convenient screen location by positioning the pointer on the title bar, pressing the left mouse button, then dragging the display to the desired location. The CRT context keys keypad may be obscured by another window when keyboard focus is changed. It can be raised to the top again by clicking on and giving keyboard focus to its parent, the system window.

---

### Summary - CRT Context Keys

**CRT Context Key** A CRT context key is any one of the 16 pushbuttons on the *CRT Context Keys* keypad, used to recall a preconfigured screen environment. The *CRT Context Keys* keypad is displayed by:

Clicking on the system window *Menu* button.

Clicking on the *Windows* item in the resulting pull-down menu.

Clicking on the *CRT Context Keys* item in the resulting cascading menu.

- Clear Button** The Clear button on the CRT context keys keypad is used to clear a CRT context key of previous assignments. To do so, first click on *Clear*. Next, click on the CRT context key to be cleared. The previous CRT context assigned to the key will be cleared.
- Context** A user's Context is the user's working environment on the PWC90 console. This includes the preferred size, shape, location, number and contents of operator windows on the screen, as well as the size and position of Quick key keypads associated with the operator windows.
- Login Layout Button** The Login Layout button is located at the top of the *CRT Context Key* keypad, above the CRT context keys and below the title bar. The displays assigned to this button will appear automatically when the user logs in.
- Set Button** The Set button on the *CRT Context Keys* keypad is used to assign the displays currently on the screen to any one of the CRT context keys on the keypad. (Any pop-up windows present will be ignored.) To do so, first make sure that the size, location and contents of the operator windows present are as desired. Next, click on *Set*. Keys which have already been assigned are unavailable and will be stippled out; click on the quick key to be set to call up the current display(s). Enter the key label in the resulting pop-up window, and click on *OK* or press **Return** to complete the operation.

## SECTION 12 - PRINTER REVIEW

### INTRODUCTION

Messages which have been sent to a printer or file can be displayed in an operator window using the printer review display.

To access the *Printer Review* display, click on the *Select* item on the operator window menu bar, then click on the *Printer Review* item in the resulting pull-down menu (Figure 12-1).

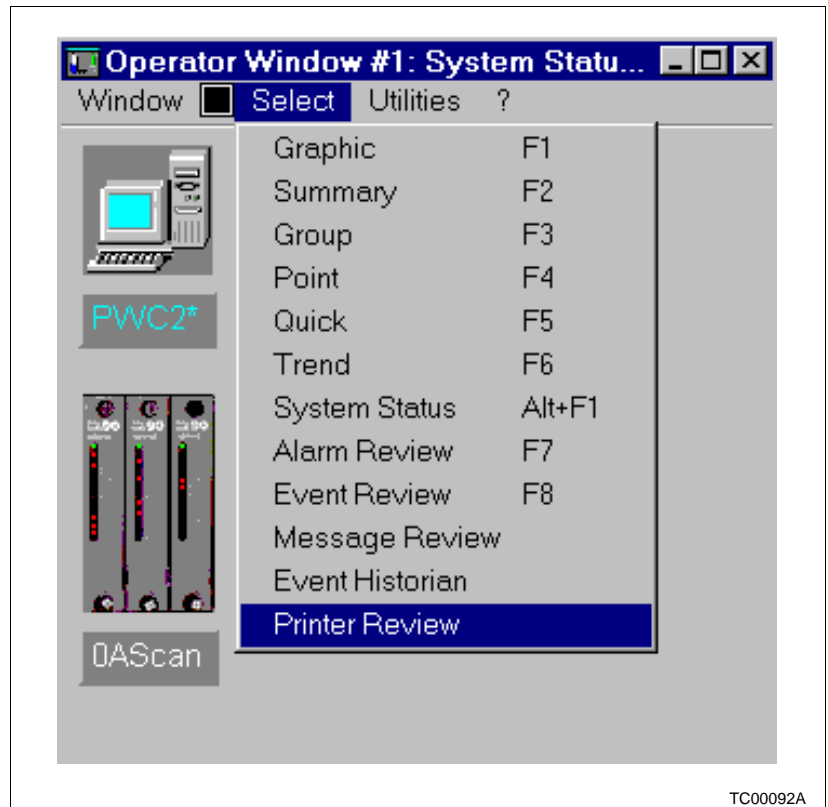

Figure 12-1. Select Menu With The Printer Review Option Selected

The *Printer Selection* window (Figure 12-2) will appear.

This window contains a list of devices configured on the network. (Items in this list can be configured using the *Printer Assignment* utility, described in the **Personal Work Center 90 Configuration** instruction.)

Messages are divided into various message classes and message types. Messages of different message classes and message types can be configured to be routed to different printer devices, which can be actual hardcopy printers, or files. (Con-

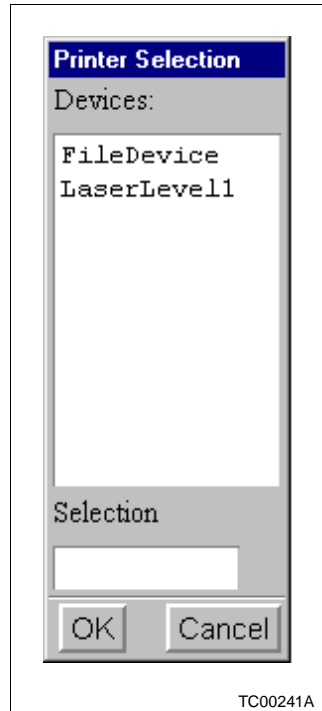

Figure 12-2. Printer Selection Window

tact your system administrator for details if you have questions on how message routing and devices are configured on your system.) Only messages which belong to the message classes which have been configured for the selected device are shown.

In the *Printer Selection* window, click on the name of the device whose messages are to be displayed. The device name will be highlighted. Click on *OK*, or double click the entry, to complete the selection operation. The *Printer Review* display (similar to that shown in Figure 12-3) for the selected device will appear in the operator window.

One message is shown per line. The total number of lines available in the *Printer Review* display is determined by the file size configured for the selected device using the *Printer Assignment* utility (described in the **Personal Work Center 90 Configuration** instruction, as noted above). When the maximum number of lines in the printer review have been reached, a new message sent to the device will cause the oldest message in the printer review to be deleted.

Messages of different message classes and types in the *Printer Review* display can appear in different colors and be indented different amounts of space, depending on how *Message Routing* (described in the **Personal Work Center 90 Configuration** instruction) has been configured on the PWC90 console. This feature is designed to help the user locate messages of a particular type or class quickly and easily.

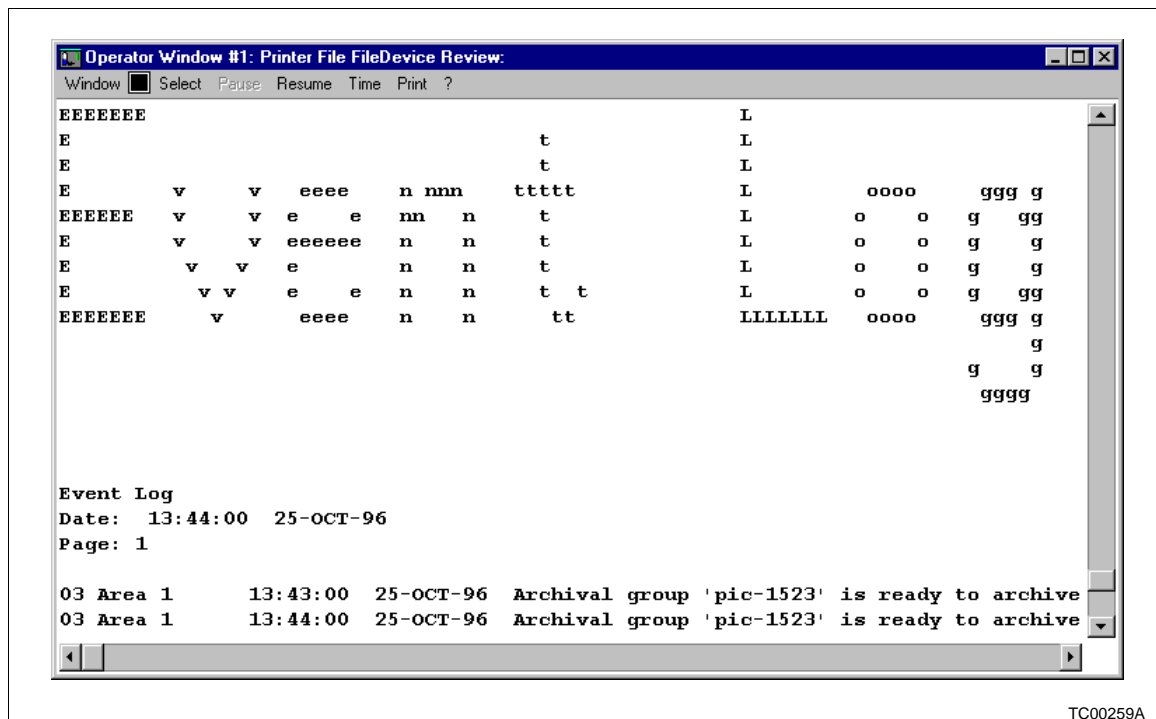

Figure 12-3. Printer Review Display

### USING PRINTER REVIEW

The messages in the *Printer Review* display are shown in increasing time order, i.e., older messages appear above newer messages. Initially, messages in the *Printer Review* display are positioned so that the newest message appears on the bottom line.

#### Scrolling the Printer Review Display

Use the vertical scrollbar to view messages which do not fit initially on the *Printer Review* display. Scroll up to view older messages, scroll down to view newer messages. Click the arrow buttons in the scrollbar (▲, ▼) to scroll one line per click. The **Pg Up** and **Pg Dn** commands can also be used to scroll up or down by the number of lines visible in the operator window.

Whenever the *Printer Review* display is scrolled, it is put into pause mode.

#### Pause/Resume the Printer Review Display

The operating mode of the *Printer Review* display, which determines the behavior of the display when a new message is sent to the selected device, can be in one of two modes:

- Update mode.

- Pause mode.

The *Printer Review* display initially appears in update mode by default. The *Pause* and *Resume* options on the *Printer Review* display menu bar are used to select the operating mode of the display. Pause mode is useful when reviewing older messages, to prevent them from scrolling up and off the display. Click on the *Pause* option to select pause mode, click on *Resume* to return to update mode.

When the display is in update mode:

- The *Resume* option is stippled out.
- The message appearing on bottom line is always newest message.
- When a new message is received, it is inserted at the bottom line. Older messages will scroll up one line.

When the *Printer Review* display is in pause mode:

- The *Pause* option is stippled out.
- The message appearing on bottom line may not be newest message.
- When a new message is received, older messages are not moved.

If new messages are received while the display is in pause mode, the position of the vertical scrollbar will change to indicate the current position of the displayed portion of the *Printer Review* display.

Scrolling the *Printer Review* display (by using the vertical scrollbar, **Pg Up** or **Pg Dn** commands) also puts the display in pause mode. Click on *Resume* to return to update mode (simply moving the vertical scrollbar to the bottom does not return the printer review to update mode).

---

### Time Selection

The *Time* option on the *Printer Review* display menu bar can be used to position the top line of the printer review on a message which occurred at a time of interest.

Click on the *Time* option; the *Time Selection* window appears (Figure 12-4).

Enter the time of interest in the format:

HH:MM:SS DD-MMM-YY

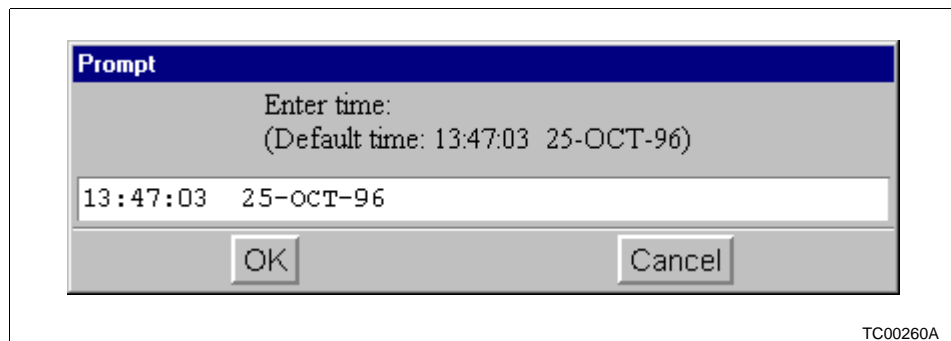

Figure 12-4. Time Selection Window

Only the parameters (i.e., hours, minutes, day, etc.) which are different from the displayed default time need to be entered. Any parameters not entered will assume the corresponding values from the default time. The exception to this is the value for seconds, which becomes zero if not specified.

For example, assume the default time shown in the *Time Selection* window is:

14:25:30 20-DEC-95

The following entries would then be interpreted as shown in Table 12-1:

Table 12-1. Time Entry

Entry	Time
14	14:25:00 20-DEC-95
3	03:25:00 20-DEC-95
16:50:48	16:50:48 20-DEC-95
12-NOV	14:25:00 12-NOV-95

Click on *OK* to select the entered time. The *Printer Review* display is placed in pause mode. The display will scroll so that the message on the top line is the first (oldest) message available with a time stamp equal to or more recent than the selected time. (If the selected time is older than the time stamp of the oldest message, the oldest message is displayed on the top line. If the selected time is more recent than the time stamp of the newest message, the newest message is displayed on the bottom line).

When *OK* is clicked, the *Time Selection* window closes.

---

### Printing Messages

The *Printer Review* display can also be used to reprint messages.

Click on the *Print* option in the *Printer Review* display menu bar. The *Select Time* window appears.

The *Select Time* window allows a time interval and a reprint device to be selected. The default time interval spans the time between the first and last messages visible in the *Printer Review* display. This may be changed by editing the *From* and *To* times in the text entry boxes. All messages in the *Printer Review* display which have timestamps between these two times will be sent to the specified reprint device. The name of the reprint device is shown to the right of the *Device* pushbutton. By default, the reprint device is the same as the current printer review device. A different device may be selected by clicking on this pushbutton, which displays the *Printer Selection* window (Figure 12-2).

Once the desired time interval and reprint device have been selected, click on *OK* to reprint the messages. Reprinted messages are preceded by a multi line *Device Reprint* banner, which includes the time at which the reprint was requested. Note that if the reprint device is the same as the current printer review device, the banner and reprinted messages will appear in the *Printer Review* display.

---

## SECTION 14 - TAG SUMMARIES APPLICATION

---

### INTRODUCTION

The tag summaries application provides an interface for querying tag information and producing tag summary reports. The query is viewed in one of three ways: design view, SQL view, or datasheet view. Several predefined queries are provided with this application. The operation of this application is described in this section.

---

### USING TAG SUMMARIES

The *Tag Summary* application is opened in the system status display by using the pull-down menu under a server Icon and selecting *Server Tag Summary*. This will launch the *Tag Summary* application for that server.

When the application is initially invoked, the user is presented with a dialog containing the names of quarries stored locally and on the current server (Figure 14-1).

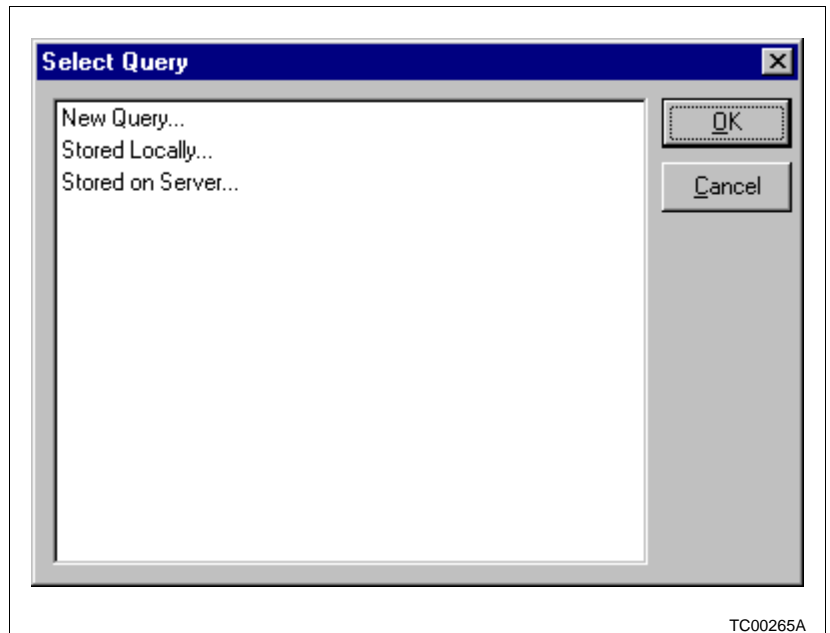

Figure 14-1. *Select Query Window*

If the user chooses *New Query* the screen (Figure 14-2) in which only the *New* and *Open* query options are displayed.

Alternatively, the application can be supplied with a saved query file name as a command line argument, in which case

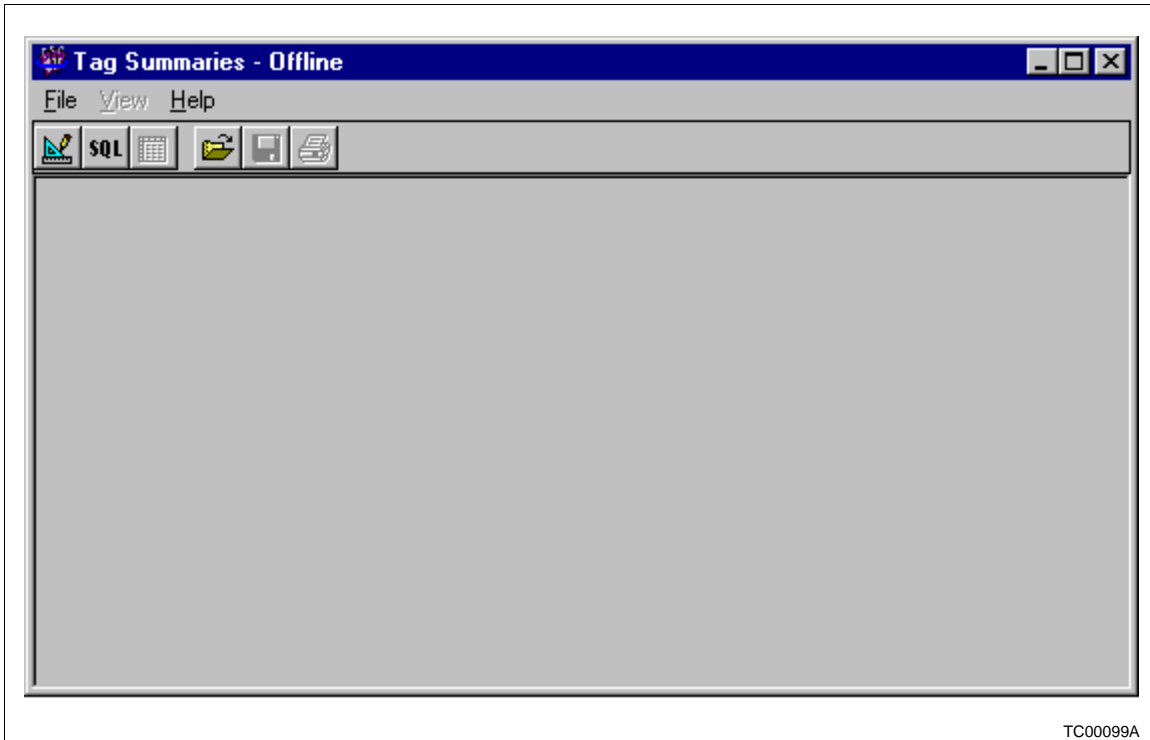

Figure 14-2. Tag Summaries Window

the query file is loaded and the user is presented with the design or SQL view shown in Figure 14-3 or Figure 14-4. In this mode, only the print option is enabled.

---

### Designing a Query

To design a query, click on the design view toolbar option, or select *New* query option from the file menu **Alt-F N**. This opens up a design sheet to enter query parameters. The user is presented with a tree view of all tag classes. Clicking on a tag class will display the tag atoms, in that class, in the tag atom list to the right of the class tree. Double-clicking on a tag atom will insert the atom in the design grid shown below the tree view. Alternatively, the name of the tag atom may be typed into the *Field* cell of the grid shown in Figure 14-3. The user may override any of the default values presented on the grid. The allowable values for *Sort* are: **Yes**, **No**, **Asc**, and **Desc**; for *Shown*: **Yes** and **No**; and for *Format*: **Numeric**, **Text**, and blank (defaults to Text). The grid performs text completion when the user types in the first letter of a value and presses Enter. Query criteria are entered in the *Criteria* and the four *Or* fields under the criteria field. The allowable expressions for the criteria fields start with a comparison operator (=, <>, <, <=, >, >=, like) followed by an expression. If omitted, the operator defaults to '='. The resulting SQL select statement can be viewed using the SQL view.



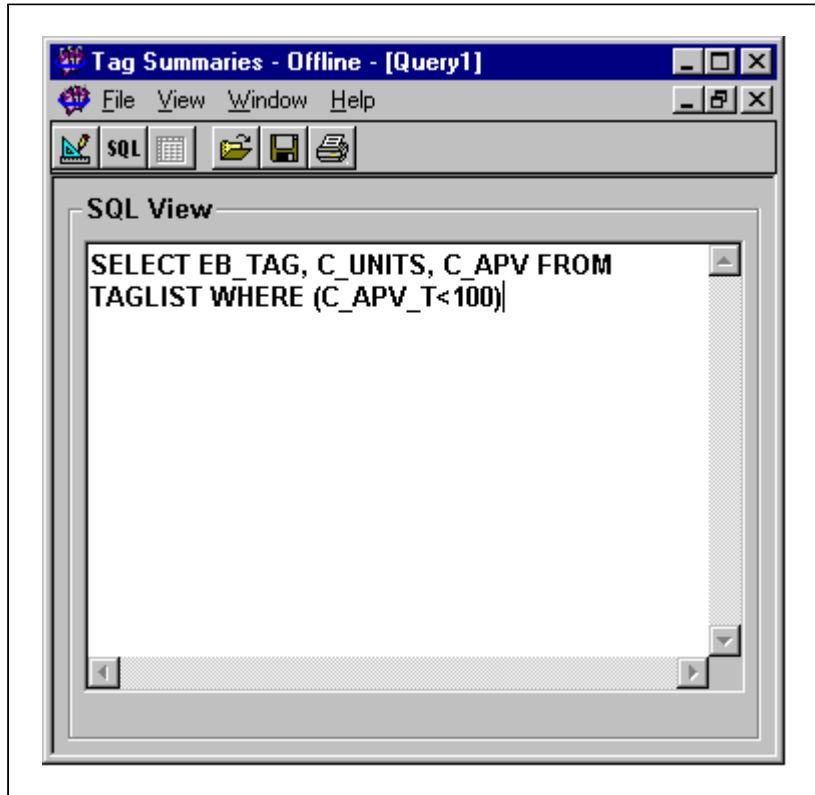

Figure 14-4. SQL Query Window

For example, the following SELECT statement finds the tag name and description of all unacknowledged tags.

```
SELECT EB_TAG, C_DESC
FROM TAGLIST
WHERE EB_ACK = 1
```

The clauses in a SELECT statement must be used in the order shown above. For example, if the statement includes a WHERE clause and an ORDER BY clause, the WHERE clause must precede the ORDER BY clause.

The select clause normally consists of a series of column names (separated by commas).

The select list, however, can also include one or more expressions (separated by commas), where an expression is a constant, tag atom name, or a combination of these connected by arithmetic or bit-wise operators and parentheses. The select list has this syntax:

```
SELECT expression [, expression...]
```

Each column name must be separated from the following column name by a comma.

The order in which you list the column names determines the order in which the columns appear in the summary.

When summary results are displayed, the atom name selected is used as the default column heading. To produce more readable reports, the user can specify a different column heading by using the AS operator.

For example, to change EB\_TAG to Tag Name in the preceding query, enter the following statement:

```
SELECT C_EB_TAG AS 'Tag Name', C_DESC
FROM TAGLIST
WHERE EB_ACK = 1
```

**NOTE:** Character strings must be enclosed in single quotation marks (') when you enter or search for them.

Computations can be performed with data from numeric atoms or on numeric constants in a SELECT clause by using arithmetic operators. Arithmetic operators let the user add, subtract, multiply, and divide numeric data.

---

## ARITHMETIC OPERATORS

Table 14-1 show the supported arithmetic operators and their symbols.

Table 14-1. Arithmetic Operators

Symbol	Operation
+	Addition
-	Subtraction
/	Division
*	Multiplication

The following example uses the subtraction operator to show the deviation from setpoint by subtracting the process value from the setpoint value. The column heading is also set to Deviation using the AS operator.

```
SELECT EB_TAG, C_DESC, C_APV - C_ASP AS 'Deviation'
FROM TAGLIST
```

---

## Arithmetic Operator Precedence

When there is more than one arithmetic operator in an expression, multiplication, and division are calculated first, followed by subtraction and addition. When all arithmetic operators in an expression have the same level of precedence, the order of execution is left to right. Expressions within parentheses take precedence over all other operations.

The user can also use parentheses to change the order of execution. Calculations inside parentheses are evaluated first. If parentheses are nested, the most deeply nested calculation has precedence.

---

### **WHERE CLAUSE**

The WHERE clause in a SELECT statement specifies the criteria for which tags to retrieve. The WHERE clause has the following syntax:

WHERE search\_conditions

Search conditions, or qualifications, in the WHERE clause include:

- Comparison operators (such as =, < >, <, and >).

WHERE C\_APV > C\_RANGLO + EB\_SPAN \* 0.5

- Pattern matches (LIKE and NOT LIKE).

WHERE EB\_TAG like 'FIC%'

- Combinations of these conditions (AND, OR).

WHERE C\_APV < 5000 and C\_APV > 2000

---

### **COMPARISON OPERATORS**

Table 14-2 show the supported comparison operators and their symbols.

*Table 14-2. Comparison Operators*

<b>Operator</b>	<b>Meaning</b>
=	Equal to
>	Greater than
<	Less than
>=	Greater than or equal to
<=	Less than or equal to
<>	Not equal to

The operators have the following syntax:

WHERE expression comparison\_operator expression

An expression is a constant, tag atom, or a combination of them connected by arithmetic or bit-wise operators.

---

## WILDCARDS AND THE LIKE CLAUSE

The LIKE keyword selects tags containing atoms that match specified portions of character strings. LIKE is used with text data. It takes four wildcard characters, which are in the form of regular expressions (Table 14-3).

Table 14-3. Wildcard Characters

Wildcard	Meaning
%	Any string of zero or more characters
_	Any single character
[ ]	Any single character within the specified range (for example, abcdef)
[^]	Any single character not within the specified range (for example ^abcdef)

When LIKE is used, be sure to enclose the wildcard(s) and the character string in single quotation marks. For example, using LIKE with the data in the authors table:

- LIKE 'FIC%' searches for all names that begin with the letters "FIC" (FIC101, FIC201).
- LIKE '%101' searches for all names that end with the letters "101" (FIC101, LIC101).
- LIKE '\_IC101' searches for all six-letter names ending with the letters "IC101" (FIC101, LIC101).
- LIKE '[FL]IC101' searches for FIC101 and LIC101.
- LIKE 'FIC10[^1]' searches for all names beginning with FIC10 that don't end with 1.

**NOTE:** Wildcards used without LIKE are interpreted as normal characters rather than as a pattern.

You can search for the wildcard characters themselves. To use wildcards as characters in a LIKE match string rather than as wildcards, use square brackets ([ ]) to enclose %, \_, and [. Use ] by itself.

---

## LOGICAL OPERATORS

The logical operators are AND, OR, and NOT. The logical operators AND and OR are used to connect search conditions in WHERE clauses.

AND joins two or more conditions and returns results only when all the conditions are true.

OR also connects two or more conditions, but it returns results when any of the conditions are true. The following query searches for tags names that are FIC101 or FIC102:

```
SELECT EB_TAG, C_DESC
FROM TAGLIST
WHERE EB_TAG = 'FIC101' OR EB_TAG = 'FIC102'
```

---

### ***Logical Operator Precedence***

When more than one logical operator is used in a statement, NOT is evaluated first, then AND, and finally OR. Arithmetic (and bit-wise) operators are handled before logical operators.

---

### ***ORDER BY CLAUSE***

The ORDER BY clause sorts query results by one or more columns. A sort can be ascending (ASC) or descending (DESC). If neither is specified, ASC is assumed.

The following query returns results ordered by EB\_TAG:

```
SELECT EB_TAG, C_DESC
FROM TAGLIST
ORDER BY EB_TAG
```

If more than one column is named in the ORDER BY clause, sorts are nested. The following statement sorts the tags first by Tag type in descending order, and then by tag name in ascending order:

```
SELECT EB_TAG, EB_TAGTYPE, C_DESC
FROM TAGLIST
ORDER BY EB_TAGTYPE desc, EB_TAG
```

---

### ***Query Results***

The query results are displayed in the datasheet view of the Tag Summaries application. Each column in the table has a heading which comes from the Atom name or the specified string in the query design (Figure 14-5).

Figure 14-5 is the results of the example query:

```
SELECT EB_TAG AS 'Tag name', C_APV, C_ASP, C_RANGHI, C_APV -
C_ASP AS 'Deviation'
FROM TAGLIST
WHERE RANGHI < 2500
ORDER BY EB_TAG
```

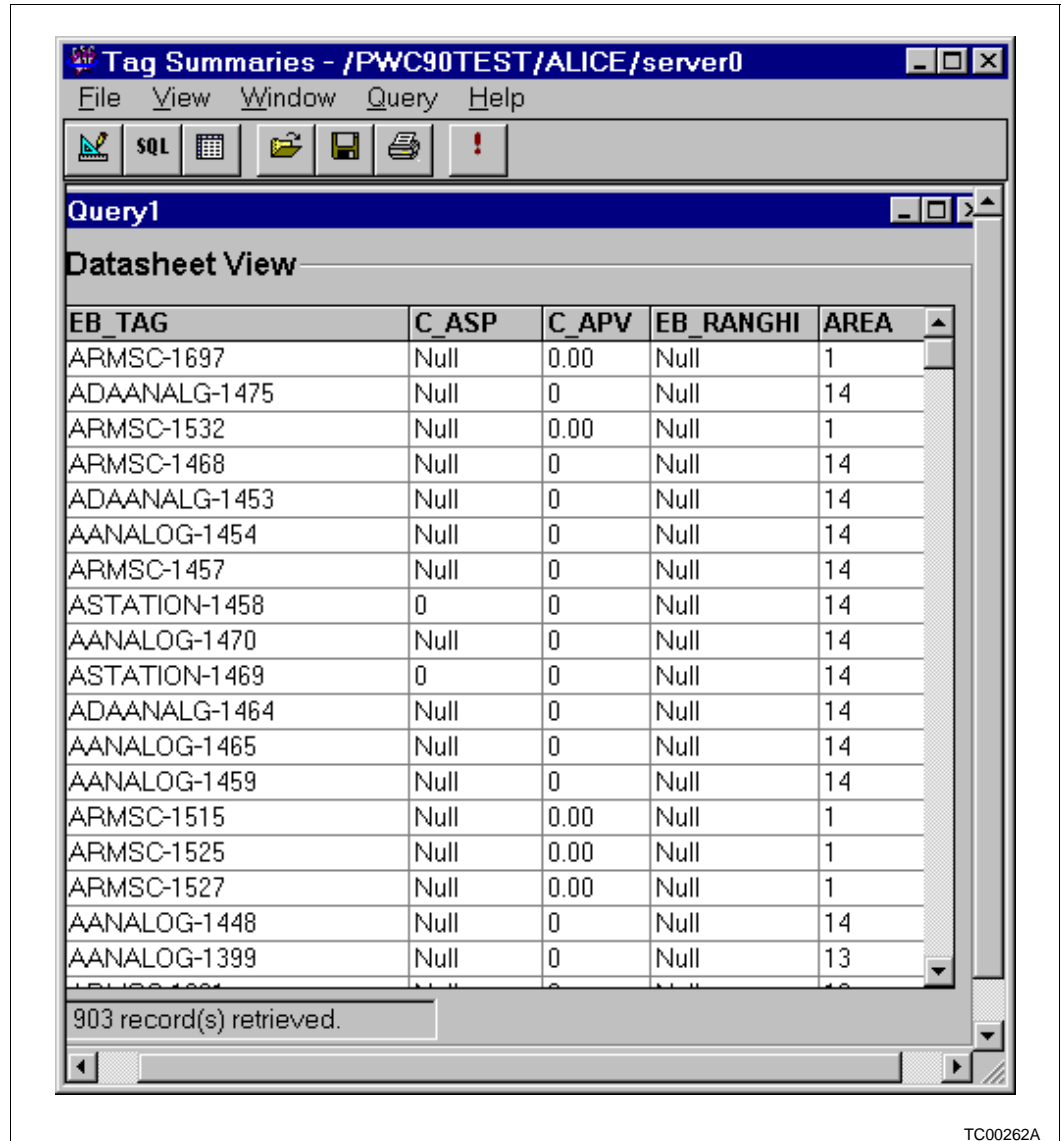

TC00262A

Figure 14-5. Query Results

Table 14-4. Datasheet View Translation Example

Column Title	SQL Clause	Explanation Of Values
Tag Name	EB_TAG AS 'Tag Name'	Tag Name as entered in the database.
C_APV	C_APV	Value of the C_APV Process Value (PV) Tag.Atom.
C_ASP	C_ASP	Value of the C_ASP Set Point (SP) Tag.Atom.
EB_RANGHI	EB_RANGHI	Value of the EB_RANGHI High Range Tag.Atom.
Deviation	C_APV - C_ASP AS 'deviation'	The deviation of the Process Value (PV) from the Set Point (SP) of the tag.

---

### **PRINT RESULTS**

While in the datasheet view select *Print* from the *File* pull-down menu or click on the printer icon in the tool bar of the *Tag Summaries* window.

---

### **Query File Operations**

Open a query by selecting the *Open Query* option from the file menu or use **Alt-F-O**. Select the path of the query and click *OK* or click *Cancel* to exit the *Open Query* window.

Close a query by selecting *Close Query* from the *File* menu or use **Alt-F-C**. If changes have been made to the query the application will give you the option to save it before it discards the changes.

To save a query select *Save Query* from the *File* menu or **Alt-F-S**. Also there is a *Save As* option in the file menu. After a save option is selected the operator is to provide a path and name to save the file under. What is saved depends on the user's last action. If the last change was to the design grid, then the values of the grid are saved. However, if the last change was to the SQL select statement, then that is saved. The interface currently does not re-build the design grid values from the SQL statement, so any changes made to the SQL statement are not reflected on the design grid. However, the SQL statement is built from the design grid values, and hence, it is updated every time the design grid values change.

The user is also able to print the design view form and the SQL View form. By selecting print while in one of the first two views, the corresponding form will print.

# SECTION 15 - SERVER DIAGNOSTICS

## INTRODUCTION

The server diagnostics function provides detailed information about the working status of a selected PWC90 server. The server diagnostics are presented in a series of tabbed pages (Figure 15-1). The *General* tab displays server information provided by all types of servers. *Messages*, the second tab, provides a scrolling list of server diagnostics and operation messages. The *Tags* tab provides a summary of tag types and the associated atoms to each tag. The application supports the possible server changes (on-line-off-line toggling) and can be started even if the server is not running.

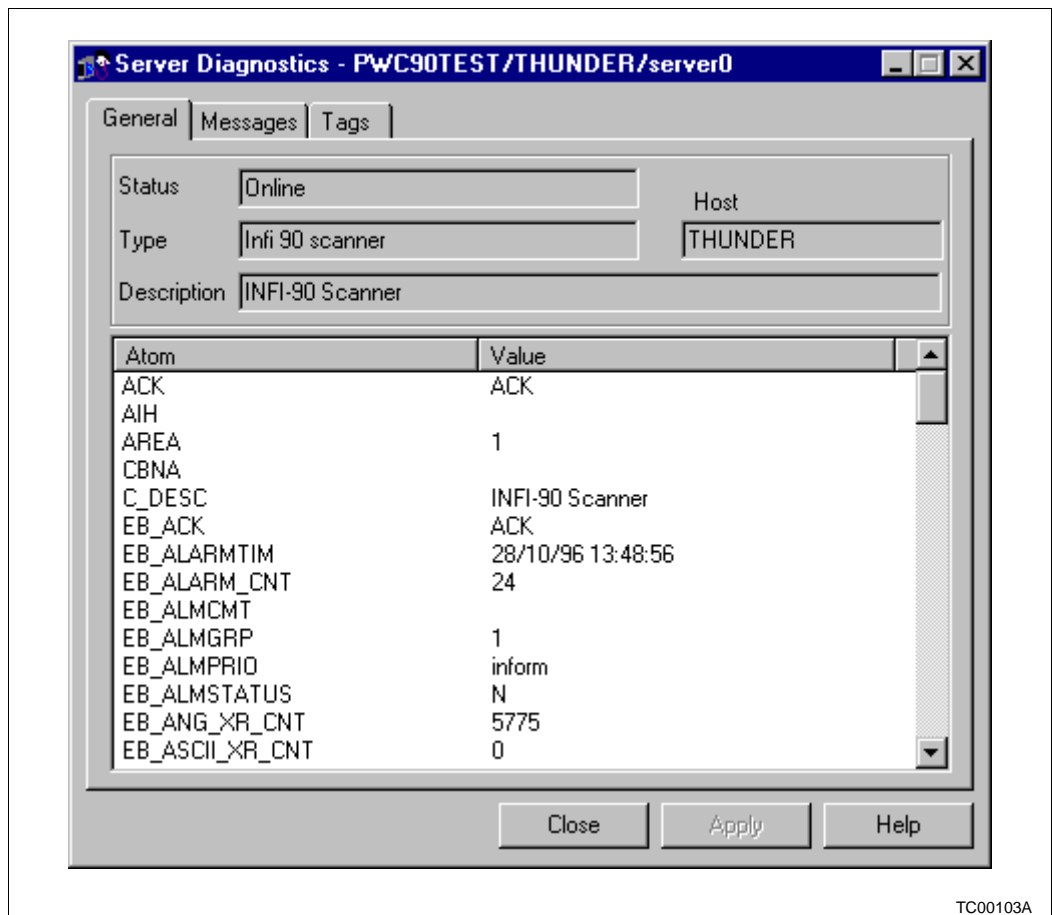

Figure 15-1. Server Diagnostics Property Sheet

The server diagnostics application is opened in the system status display by using the pull-down menu under a server icon and selecting *Server Diagnostics*. This will launch the server diagnostics application for that server.

The tab can be selected using the mouse or by switching the keyboard focus to the tabs using **TAB**, **SHIFT-TAB** and scrolling across the tabs using the left and right arrows.

---

## GENERAL TAB

The *General* tab shown in Figure 15-1 displays server status. The host, description, and type information correspond to the tag atom information in the database. The scrollable list contains the complete set of atoms belonging to the corresponding server tag and their value. These values are updated once a second.

The list can be scrolled by using the mouse to click on the up and down arrows at the side of the list or by clicking on one of the atoms and then using the up and down arrow keys on the keyboard to scroll the list.

---

## MESSAGE TAB

The *Message* tab shown in Figure 15-2 displays the server and status messages, as they are logged by the server during operation. To open the *Messages* tab window click on the *Messages* tab or by selecting the tab with the keyboard as explained in the **INTRODUCTION** of this section. This tab provides the time stamp, type, message source class and message. There is a set of predefined filters, allowing the display of a certain group of messages. Set the filter from the *Message Type* list. The four selections are:

- *System* - messages about the hardware and software.
- *Operator Action* - lists the operator actions on the system.
- *Change of State* - only when the state of a field changes.
- *All* - all of the available messages.

This tab is updated automatically to reflect changes in the current server information.

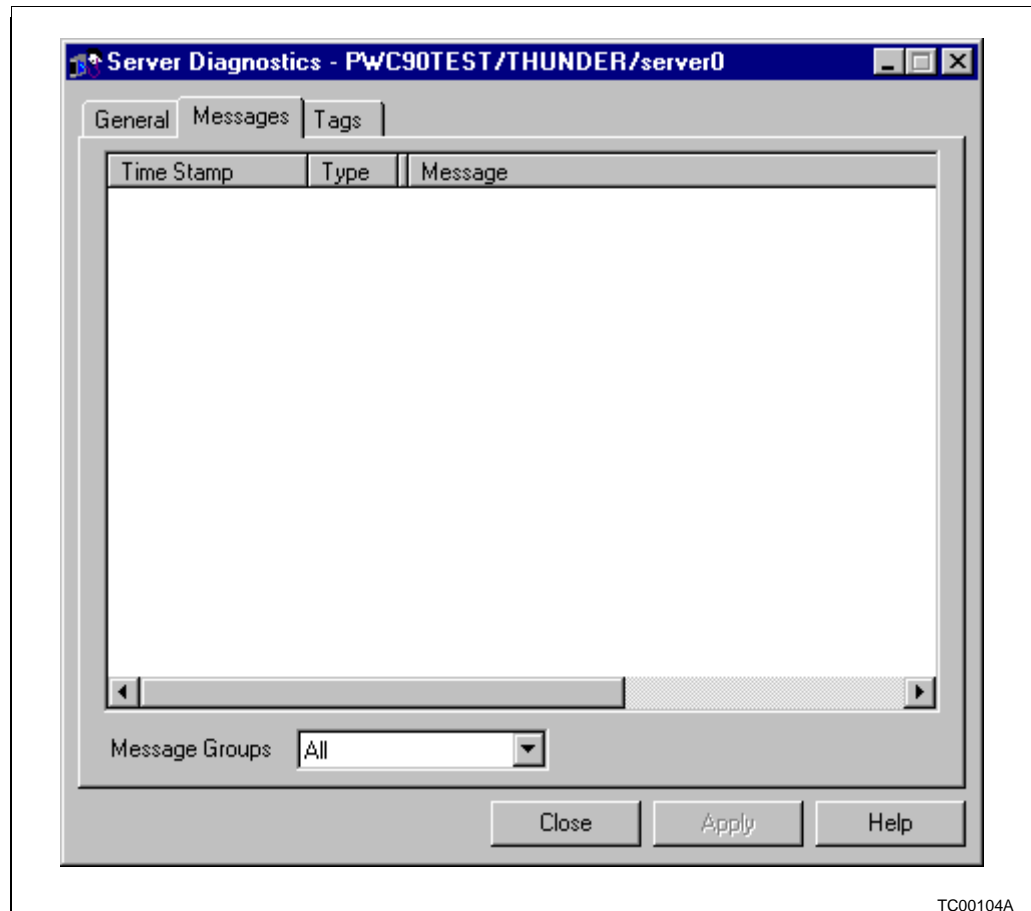

Figure 15-2. Message Tab

## TAGS TAB

The *Tags* tab window is opened by clicking on the *Tags* tab or by selecting the tab with the keyboard as explained in the **INTRODUCTION** of this section.

The *Tags* tab displays a scrollable tree of the tags existing in the data base which is accessed by the server (Figure 15-3). At the top of the tab sheet the number of tags available in the server is displayed in the *Number of Tags* field. To select a tag, click on its name in the tree control. When a tag is selected a list of the atoms associated with the tag type are displayed in the right list view and the number of atoms is displayed in the *Number of Atoms* field. To see the atoms associated with the tag, click on the node button (+) or double click the tag name. Select one of the atoms by clicking on it with the mouse. The list view on the right now displays the data format and the value of the atom selected. The icons show the available data formats for the atom and indicates the primary format from the available ones.

The following list describes the data format icons:

- ✓ - data format supported.
- ✔ - primary data format.
- ✗ - data format not supported.

This tab updates automatically to reflect changes in the server information.

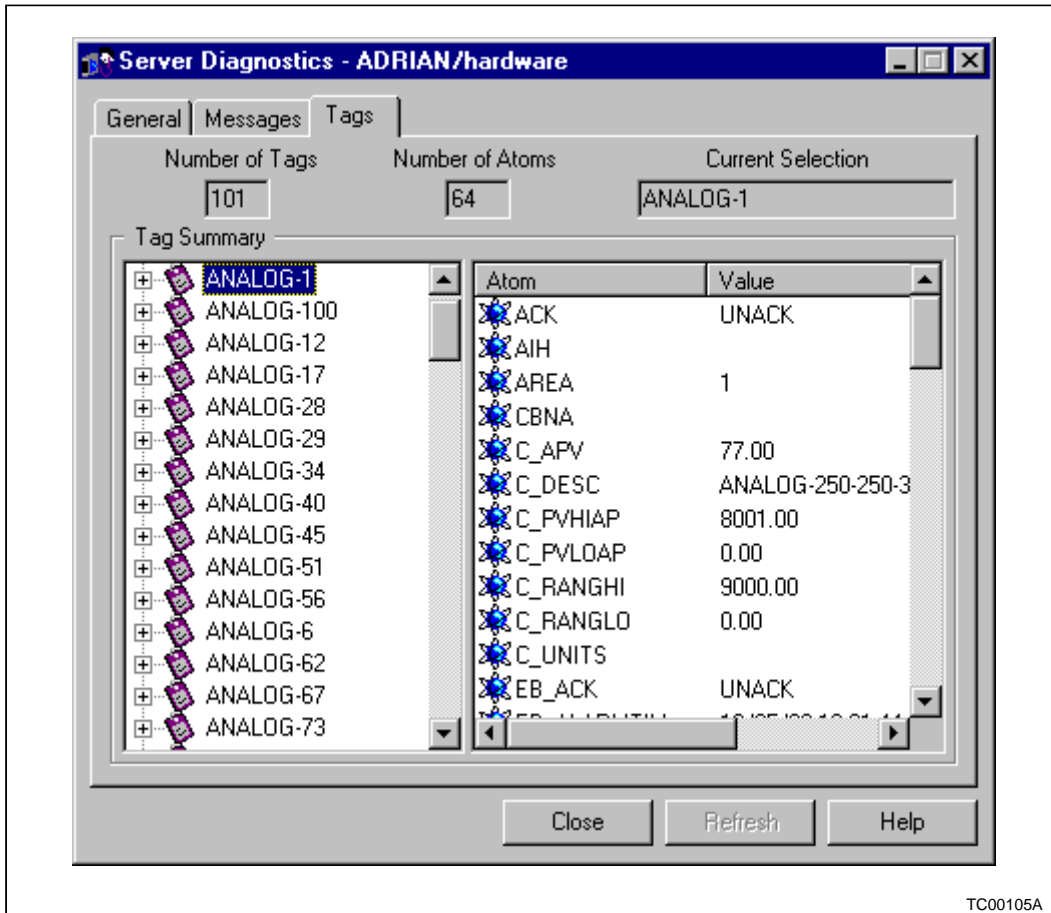

Figure 15-3. Tags Tab

---

## SECTION 16 - MODULE DETAILS

---

### INTRODUCTION

The *Module Details* application provides detailed information about the operational status of a selected INFI 90 OPEN module. The *Module Details* are presented in a series of tabbed pages (Figure 16-1). The first tab, *General*, displays the module address and module operation information. *Status*, the second tab, provides a scrollable list of module status error messages. The *Problems* tab provides a scrollable list of module problem report messages. *Technical* displays the status bytes of the selected module.

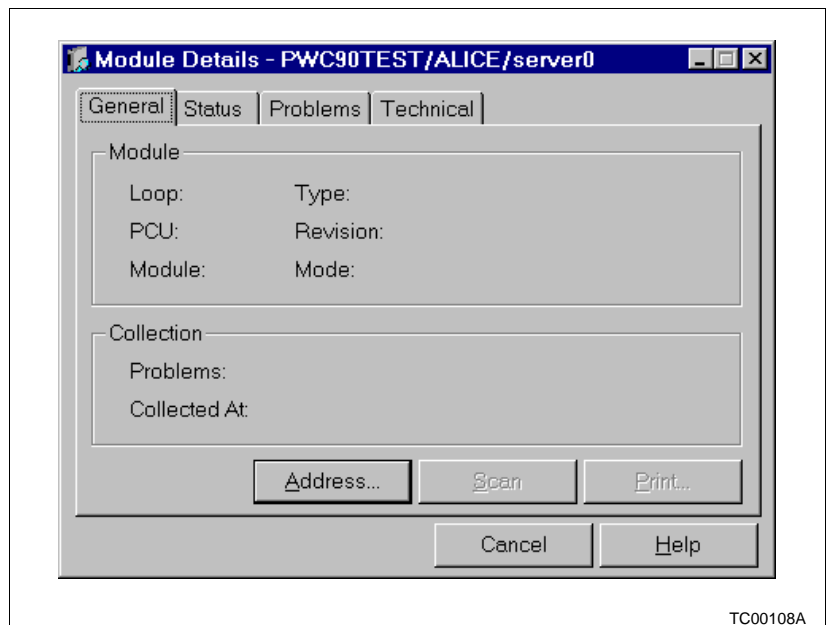

Figure 16-1. Module Details Window

The *Module Details* application is started from the system status display by using the pull-down menu under a server icon and selecting *INFI 90 Module Status*.

The tabs are selected using the mouse or by switching the keyboard focus to the tabs by using **Tab**, **Shift-Tab** and scrolling across the tabs by using the left and right arrows. The **Ctrl-Tab** combination can also be used to select the tabs.

---

### GENERAL TAB

The General tab, shown in Figure 16-1, displays the module address of a selected module. To select a different module address; click on address and enter the module address in the

dialog box. Use the up and down arrows to change the number or click on the box and enter a number with the keyboard. Click *OK* to apply the change or click on *Cancel* to exit the Address dialog box.

If an invalid address is entered the application displays a message indicating that it is not possible to scan the selected module.

A new address is then displayed in the *Loop*, *PCU*, and *Module* fields. The module type is displayed in the *Type* field. The module firm ware revision is displayed in the *Revision* field. If the application is unable to determine a revision level N/A is displayed in the field. The operating mode of the module is displayed in the *Mode* field. The possible modes are:

- *Execute* - on-line and in execute mode.
- *Configure* - on-line and in configure mode.
- *Error* - on-line and in error mode, this indication occurs when a module configuration error exists.
- *Failed* - off-line due to the existence of an internal problem.

The *Problem* field shows a number which represents the sum total of module status errors and module problem report errors. The *Collected* field shows the date and time at which the module scan took place.

To update the information in this window click scan. This function updates the display with the most current module status information.

---

## STATUS TAB

The *Status* tab, shown in Figure 16-2, displays a list of module status error messages that apply to the selected module at the time of the last module scan.

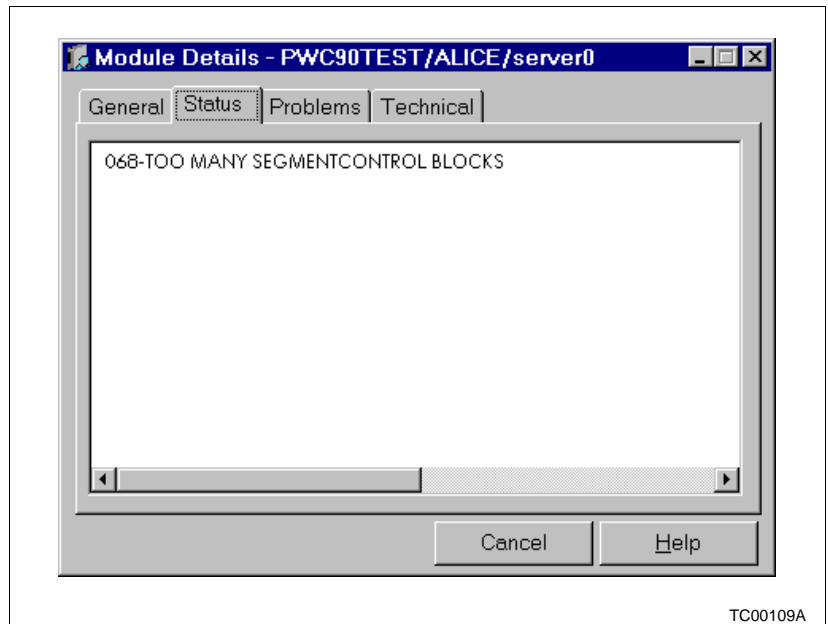

Figure 16-2. Status Tab

### PROBLEMS TAB

The *Problems* tab, shown in Figure 16-3, displays a list module problem report messages that apply to the selected module at the time of the last module scan.

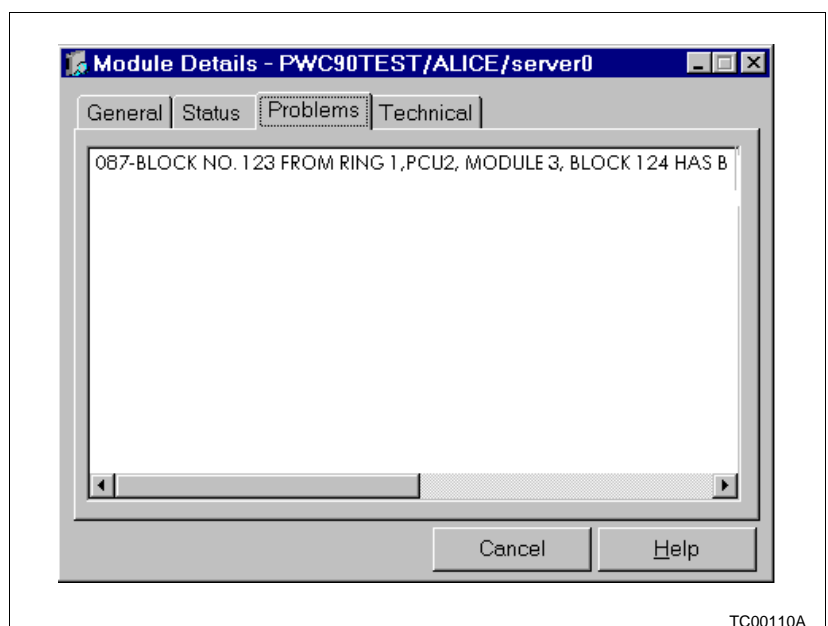

Figure 16-3. Problems Tab

TECHNICAL TAB

The *Technical* tab, shown in Figure 16-4, displays the module status bytes. The number of status bytes depends on the type of module. Some module types return five status bytes while others return sixteen bytes. Of these bytes, the first two are common to most modules. The remaining bytes are specific to a particular module. Each byte is represented with a hexadecimal value.

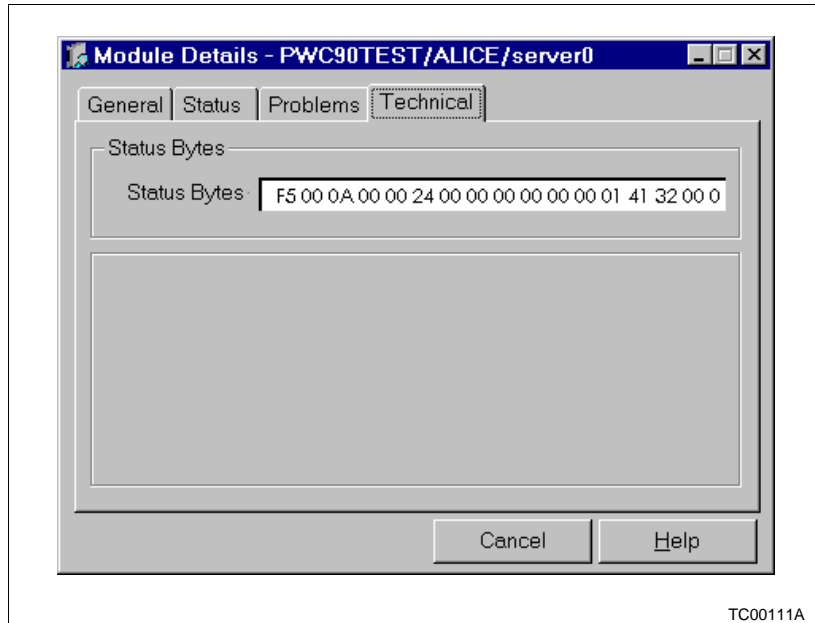

Figure 16-4. Technical Tab

Table 16-1 describes the meaning of the data that is presented in bytes one and two. Convert the hexadecimal value to a binary value then refer to Table 16-1 for further interpretation of the status bytes.

Table 16-1. Module Status Bytes

Byte	Bit							
	7	6	5	4	3	2	1	0
1	ES	MODE			TYPE			
2	FTX	BAC	RIO	LIO	CFG	NVF	NVI	DSS

The terms and acronyms are defined as:

**ES** - error summary: 0 = ok, 1 = error exists. If there is an error indicated in the status information, the bit is set to one.

**MODE** - module mode: 00 = configure, 01 = failed, 10 = error, 11 = execute.

**TYPE** - module type. Each INFI 90 OPEN module has a different type identifier.

**FTX** - first time in execute mode: 0 = no, 1 = yes.

**BAC** - summary of remote input status: 0 = ok, 1 = bad.

**RIO** - summary of local input status: 0 = ok, 1 = bad.

**LIO** - summary of local input status: 0 = ok, 1 = bad.

**CFG** - on-line configuration changes being made: 0 = no, 1 = yes.

**NVF** - nonvolatile memory failure: 0 = no, 1 = yes.

**NVI** - nonvolatile memory initialized: 0 = no, 1 = yes.

**DDS** - station status: 0 = ok, 1 = bad.

## SECTION 17 - BLOCK DETAILS

### INTRODUCTION

The Block Details function allows the user to inspect function blocks that are contained within a selected INFI 90 OPEN processor module. It displays the specifications and the outputs of a selected function block and additional information related to the function code. The user can also tune the specifications of the selected function block. It also provides various ways of jumping to other function blocks in the module. Block Details information is presented in a series of three tabbed pages (Figure 17-1).

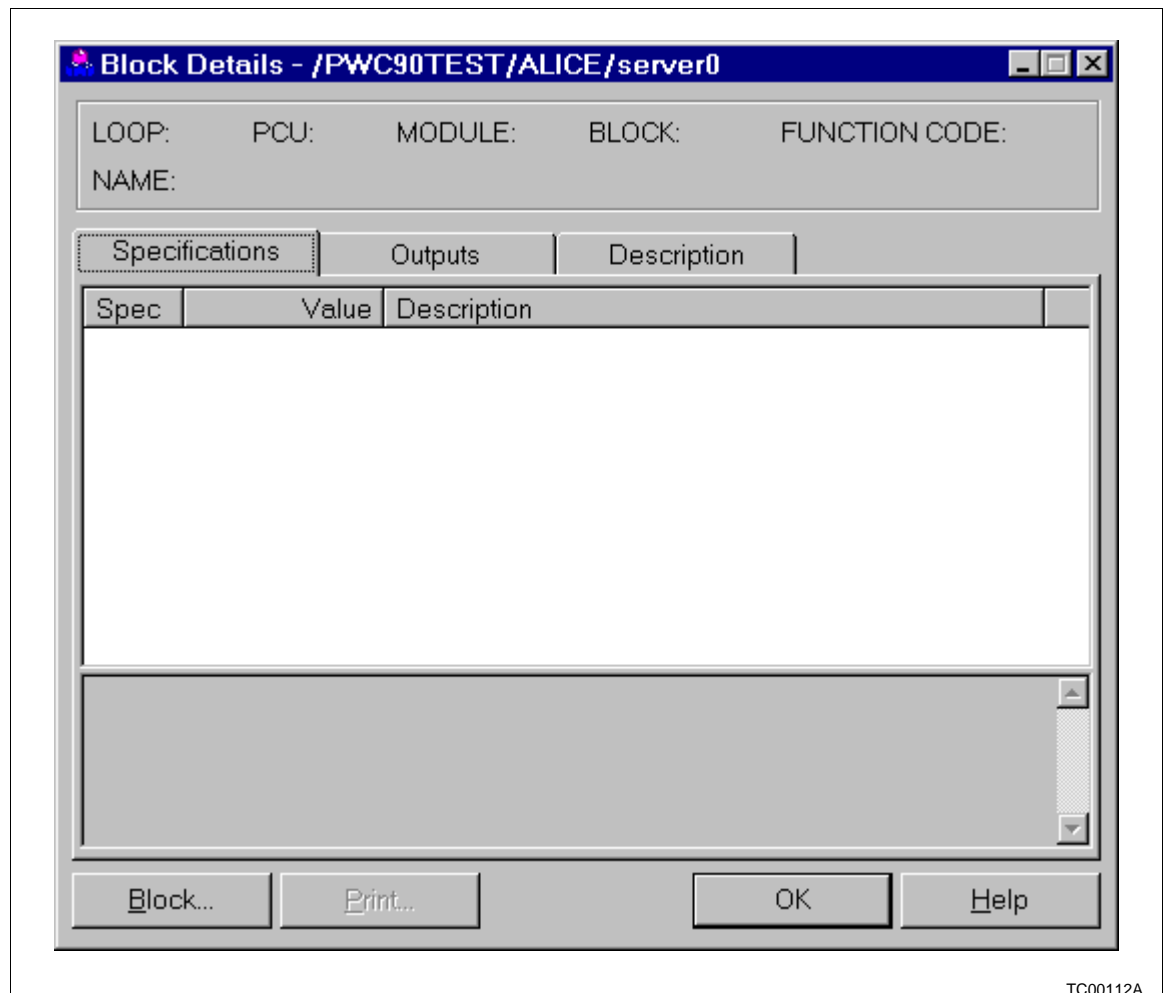

Figure 17-1. Block Details Window

At the system status display, click on a server icon in order to display a pull-down menu below the icon. Click *INFI-90 Block Details* on this menu to start Block Details. Block Details

obtains function block information from that server. Alternatively, click *Params* in a point display that references a process tag. Block Details examines the function block at the block address that is associated with the tag.

The Block Details function accepts a optional tag name argument on start-up. If a tag name is present, the application will determine the block address of the tag by interrogating the real time database. If a tag is not specified, click on *Block* and manually enter a block address. The top of this display indicates the hardware address of the function block being examined and its function code number and name.

The tab can be selected by using the mouse or by switching the keyboard focus to the tabs by using **TAB**, **SHIFT-TAB** and scrolling across the tabs by using the left and right arrows.

---

## SPECIFICATIONS TAB

The *Specifications* tab (Figure 17-1) displays a list of function code specification records which consists of these columns:

- *Spec* - the specification number.
- *Value* - the current value of the specification.
- *Description* - the description of the meaning of the specification.

Icons under the *Spec* column are used to show additional information about each specification. The following list explains each icon:



- This indicates a specification which references another function block output.



- This indicates a specification whose value may be tuned.



- This indicates a specification that does not reference another block and is not tunable.

---

## Block Button

The Block button displays a shortcut menu with commands for block movement operations. The menu commands are:

- *Address* - Displays the *Block Address* dialog box (refer to the Block Address Dialog Box section).
- *Jump History* - Displays the *Jump History List* dialog box. This command will only be enabled if a *Jump History List* exists.

- Previous Block - Jumps to the previous function block in the module. This command is only be enabled if a next block jump was done earlier.
- Next Block - Jumps to the next function block in the module.

Only Address is available until more than one address has been accessed or until a block jump has been completed. The available menu options will be enabled.

When *Address* is selected, a *Block Address* dialog box appears as in Figure 17-2. In the box enter the desired address and click *OK* to go to the new address. Click on *Cancel* to exit this dialog box.

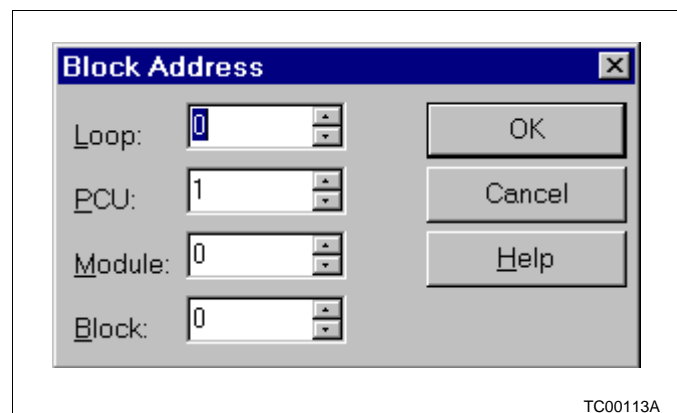
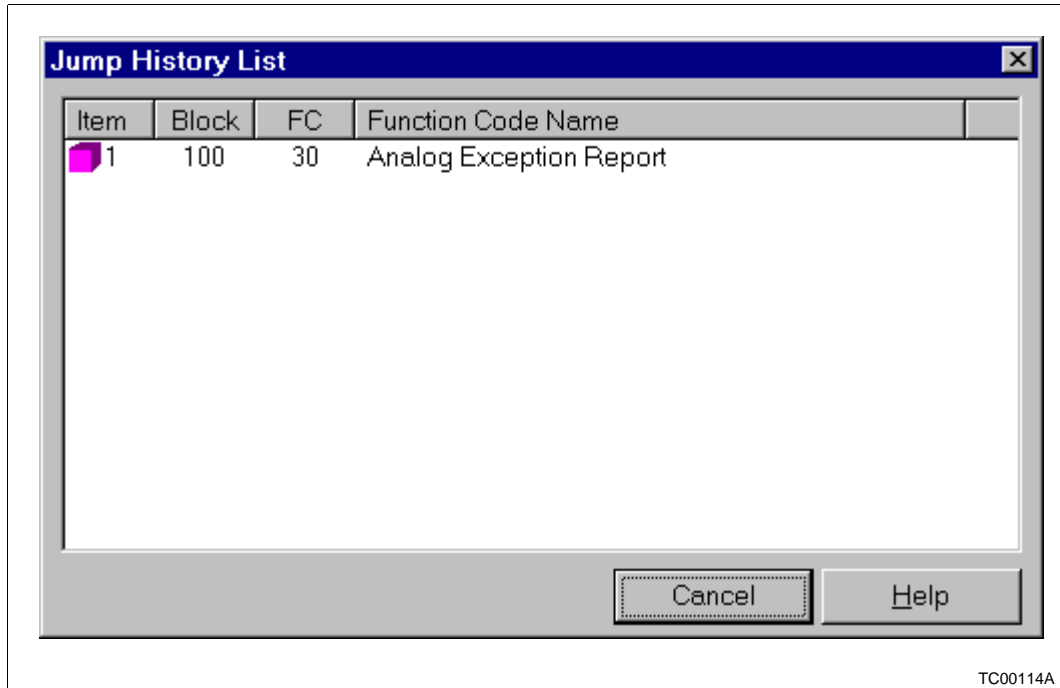

Figure 17-2. Block Address Dialog Box

When *Jump History* is selected, a list of the block addresses jumped to by specification references appears as in Figure 17-3. Any of the blocks on the list can be jumped to by double clicking on the desired block or by clicking any of these with the right button will yield a *Jump* pop-up menu under which *Jump* can be selected.



TC00114A

Figure 17-3. Jump History List Dialog Box

### Tunable Blocks

Specifications whose value may be changed while the module is in execute mode are said to be tunable. The tuning function of the specification is initiated by selecting a tunable specification with the right mouse button. A popup menu appears, and by selecting *Tune* from the popup menu a *Tuning* dialog box appears (Figure 17-4). This dialog box can also be displayed by double clicking the left mouse button on a tunable specification. Enter a new value in the *Value* box. To send the tune block command to the module click *OK* or *Apply*. *OK* will send the command and exit the tuning dialog box while *Apply* will send the command and remain in the tuning dialog box. Clicking *Cancel* will leave the tuning dialog box without changing the value. By selecting *Use Default* the default value of the specification will be inserted into the value box.

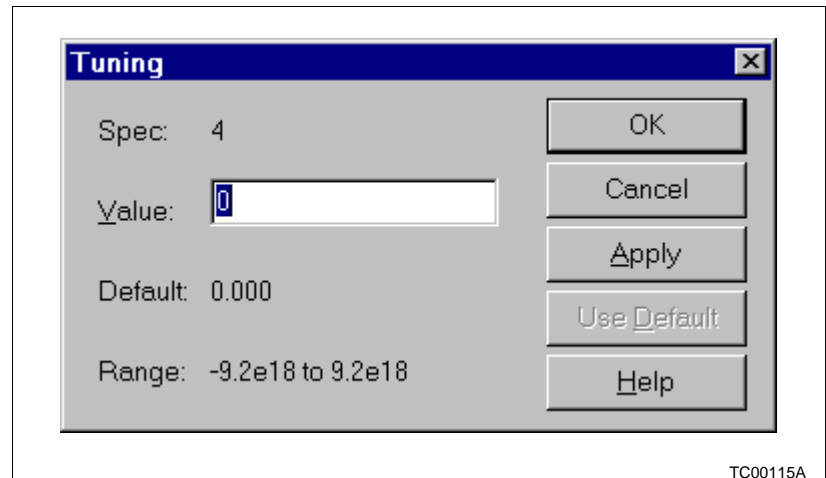

Figure 17-4. Tunable Specification Dialog Box

### Properties Option

The Properties option is available for each specification type. It can be accessed by right clicking the specification and selecting *Properties* from the popup menu. The *Properties* selection will produce a dialog box as shown in Figure 17-5. This dialog

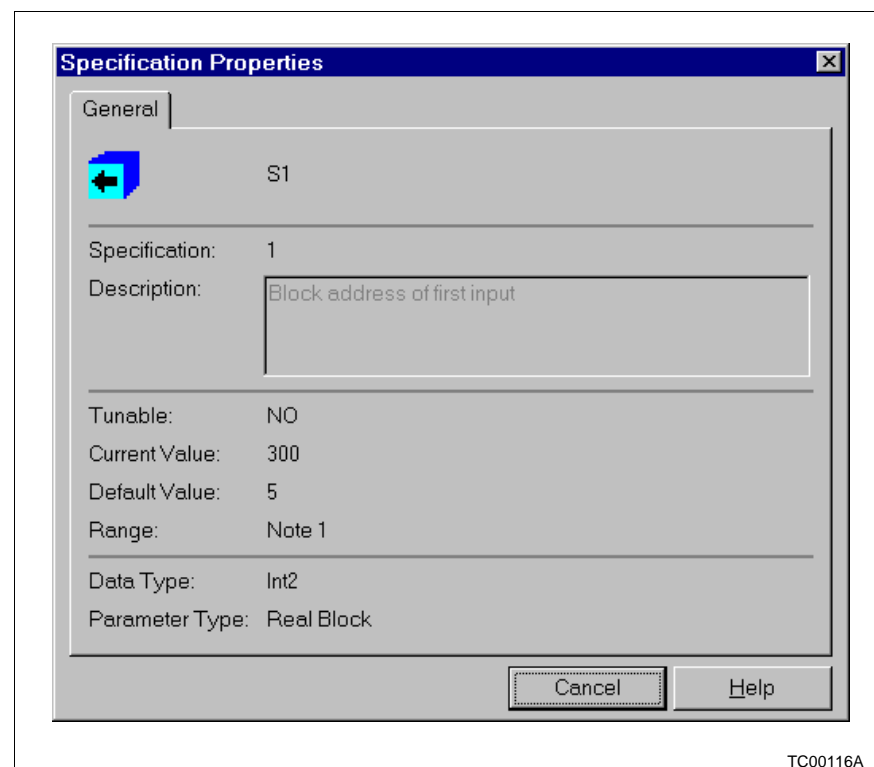

Figure 17-5. Specification Properties Dialog Box

box may be displayed directly by a double-click of the left mouse button if the specification is not a tunable specification type or a block reference type.

Select *Help* to display the application help that applies to this particular dialog box. Click *OK* or *Cancel* to exit the dialog box.

---

## OUTPUTS TAB

The Output tab (Figure 17-6) displays function block output records. The following items are shown:

- *Output* - the output number.
- *Block* - the block number that is associated with the output number.
- *Type* - the data type of the output value.
- *Value* - the value of the block output.
- *Description* - the description of the meaning of the output value.

The lower portion of the page provides additional notes on the outputs.

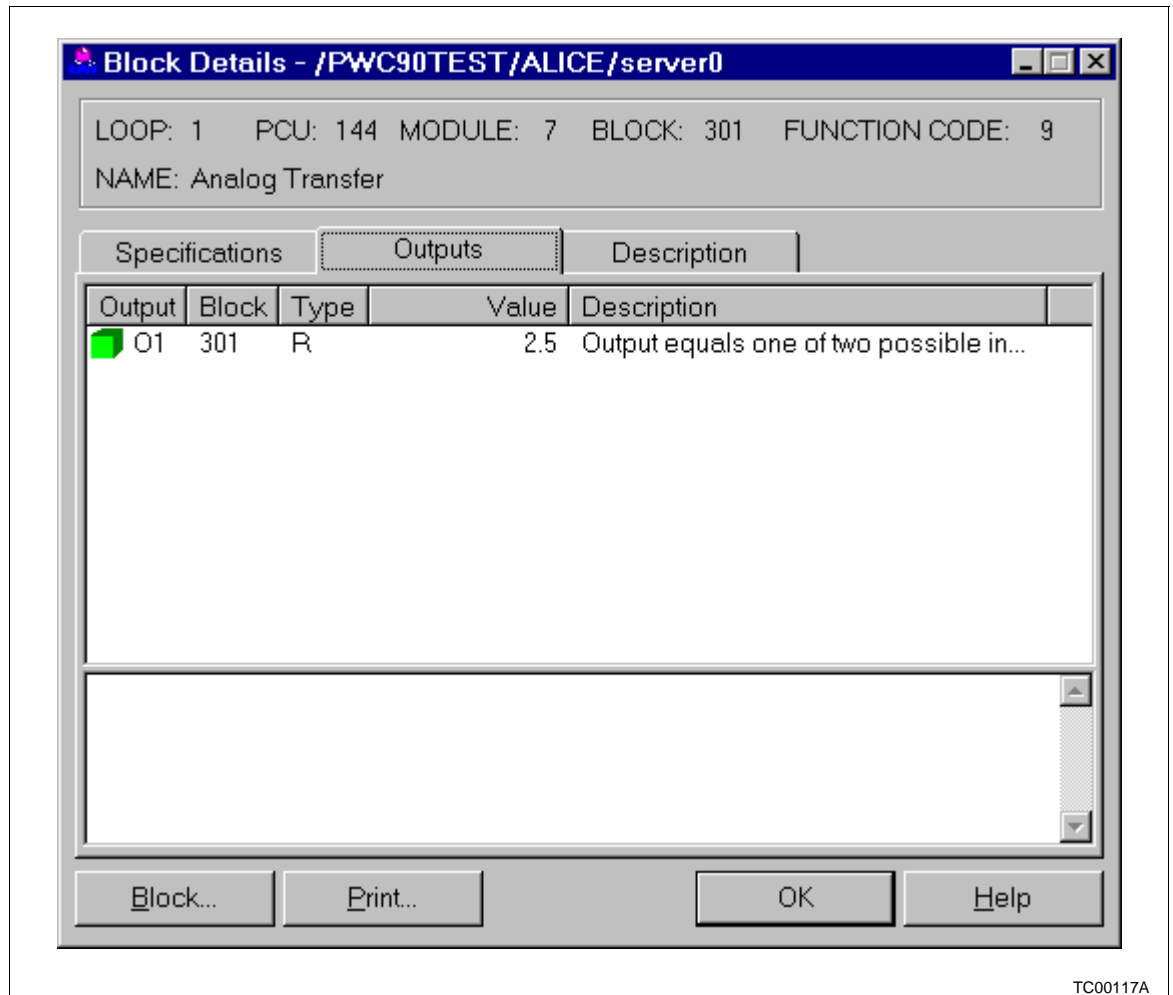

Figure 17-6. Output Tab

### DESCRIPTION TAB

The *Description* tab contains a description of the function code that is currently on display (Figure 17-7). The lower portion of the page provides additional notes on the function code.

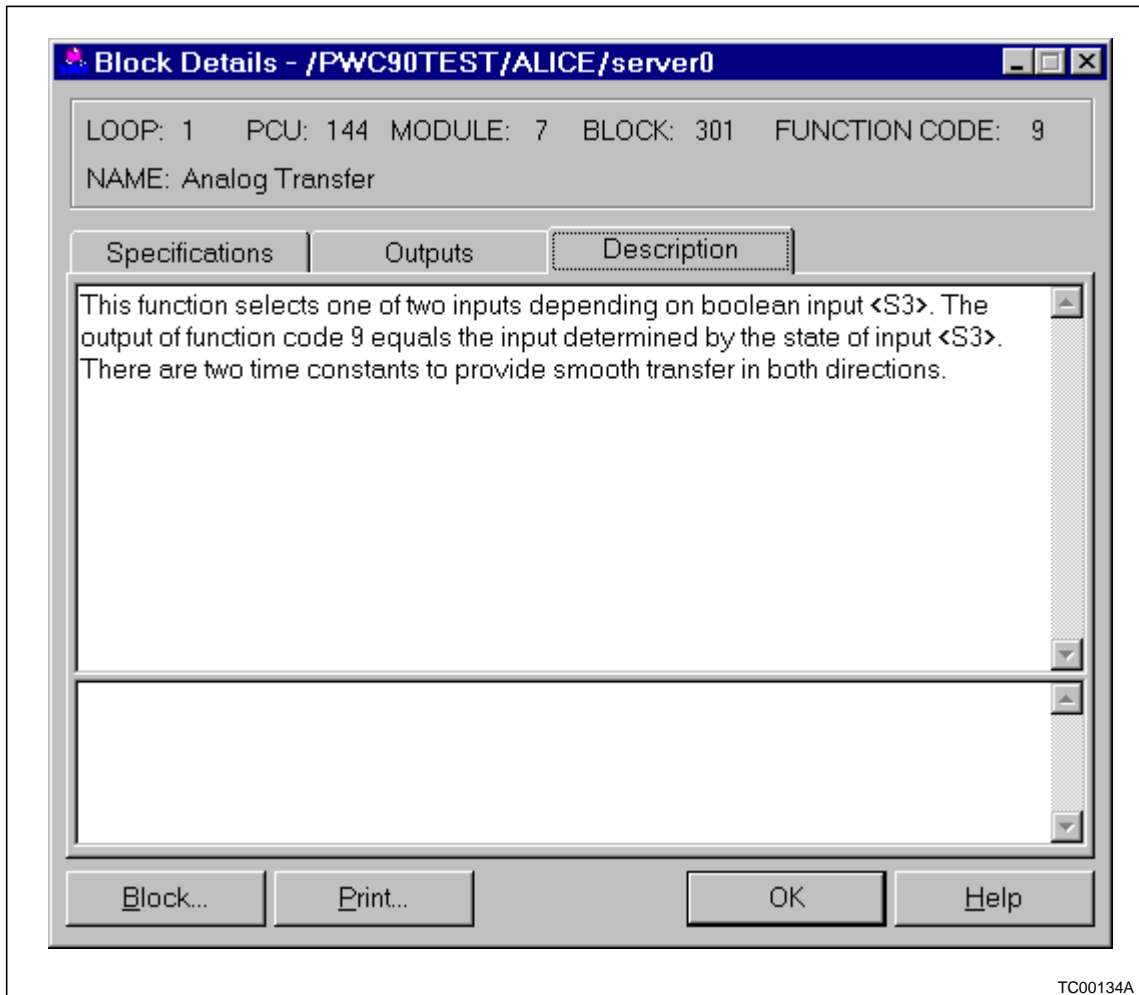

Figure 17-7. Description Tab

# Index

<b>A</b>	
Alarm groups .....	11-28
Analog	
Annunciator element.....	4-35
Standard element .....	4-35
Archive historical data .....	11-22
<b>B</b>	
Backup and restore .....	11-3
<b>C</b>	
Cascade .....	4-19
Changing password.....	3-5
Compression .....	6-12
CRT print .....	11-32
<b>D</b>	
DADIG	
Control .....	4-46
Element.....	4-44
Tag.....	4-44
DANG	
Control .....	4-43
Element.....	4-40
Tag.....	4-40
Data acquisition	
Analog.....	4-35, 4-40
Common faceplate elements .....	4-35
Control inhibit.....	4-35
Digital.....	4-38, 4-43
Functions .....	4-34
Tags.....	4-34
Text string.....	4-46
DD	
Control .....	4-26
Element.....	4-25
Tag.....	4-25
Device status .....	3-20
Digital	
Annunciator element.....	4-38
Standard element .....	4-38
<b>F</b>	
Function keys .....	2-4
<b>G</b>	
Graphics .....	7-1
Alarm acknowledgment.....	7-7
Display vectoring.....	7-5
Error indication .....	7-6
Pan.....	7-8
Zoom .....	7-9
Group display.....	4-6
<b>I</b>	
Info button .....	6-9
Input devices.....	2-1
Keyboard.....	2-3
Mouse .....	2-2
<b>L</b>	
Logging in .....	3-2
Logging out .....	3-4
Logs	
Event .....	5-2
Spreadsheet.....	5-3
<b>M</b>	
Man/auto	
DANG .....	4-43
DD .....	4-27
MSDD.....	4-30
TEXTSTR .....	4-49
Manual data entry .....	11-14
Message review .....	10-2
Mini-alarm window .....	8-1
Acknowledging .....	8-2
Filtering .....	8-2
MSDD	
Control.....	4-29
Element .....	4-27
Tag.....	4-27
<b>N</b>	
Nodes.....	3-17
<b>O</b>	
OUT .....	4-20
<b>P</b>	
Password .....	3-5
Point display.....	4-56
Print log.....	5-1
Printer review .....	12-3

# Index (continued)

- Process alarm review ..... 8-3
  - Accessing ..... 8-3
  - Acknowledgment ..... 8-4
  - Display vectoring ..... 8-5
  - Filtering ..... 8-6
  - Freeze ..... 8-9
  - Search ..... 8-10
  - Sort ..... 8-8
- Process control
  - Common faceplate elements ..... 4-14
  - Control inhibit ..... 4-13
  - Functions ..... 4-12
  - Loop control ..... 4-15
  - Tags ..... 4-13
- PWC90 faceplate
  - Analog export ..... 4-52
  - Digital export ..... 4-53
  - Module status ..... 4-54
  - Scanner Tag ..... 4-55

## Q

- Quick keys ..... 11-38

## R

- Ratio ..... 4-19
- RCM
  - Control ..... 4-22
  - Element ..... 4-20
  - Tag ..... 4-20
- Red tag descriptor ..... 4-14
- Restore historical data ..... 11-26
- RMCB
  - Control ..... 4-33
  - Element ..... 4-30
  - Tag ..... 4-30
- RMSC
  - Control ..... 4-24
  - Element ..... 4-23
  - Tag ..... 4-23

## S

- Security ..... 3-8
- SET
  - DADIG state change ..... 4-46
  - DANG value change ..... 4-43
  - Ratio index change ..... 4-19
  - RMSC value change ..... 4-24
  - Set point change ..... 4-19
  - TEXTSTR input ..... 4-50
- STATION
  - Control ..... 4-18
  - Element ..... 4-15
  - Tag ..... 4-15
- Summary display ..... 4-2, 4-4
- System event review ..... 9-2
  - Accessing ..... 9-2
  - Acknowledgment ..... 9-3
  - Filtering ..... 9-4
  - Freeze ..... 9-7
  - Sort ..... 9-6
- System events ..... 9-1
- System features ..... 3-7
- System status display ..... 3-15

## T

- Tag
  - Control ..... 4-13
  - Data acquisition ..... 4-34
- TEXTSTR
  - Application driven ..... 4-49
  - Block driven ..... 4-50
  - Control ..... 4-49
  - Element ..... 4-47
- Trend displays ..... 6-1

## U

- Utilities menu ..... 3-20

Visit *Elsag Bailey* on the World Wide Web at <http://www.bailey.com>

---

Our worldwide staff of professionals is ready to meet *your* needs for process automation.  
For the location nearest you, please contact the appropriate regional office.

**AMERICAS**

29801 Euclid Avenue  
Wickliffe, Ohio USA 44092  
Telephone 1-216-585-8500  
Telefax 1-216-585-8756

**ASIA/PACIFIC**

152 Beach Road  
Gateway East #20-04  
Singapore 189721  
Telephone 65-391-0800  
Telefax 65-292-9011

**EUROPE, AFRICA, MIDDLE EAST**

Via Puccini 2  
16154 Genoa, Italy  
Telephone 39-10-6582-943  
Telefax 39-10-6582-941

**GERMANY**

Graefstrasse 97  
D-60487 Frankfurt Main  
Germany  
Telephone 49-69-799-0  
Telefax 49-69-799-2406