

# Product Instruction P99-7

## Reset Booster Relay

Pt. No. 5319700-□

### INDEX

	<u>Page</u>
Operation	2
Routine Servicing	3
Corrective Maintenance	4
Calibration	5
Replacement Parts	6

The Reset Booster Relay is a pneumatic transmitting device which operates in conjunction with a nozzle-vane assembly to produce an output pressure which is proportional to a measured variable. The Booster Relay is always a component part of a measuring and transmitting instrument and is mounted integrally with that instrument.

**WARNING**

DO NOT INSTALL, MAINTAIN OR OPERATE THIS EQUIPMENT WITHOUT READING, UNDERSTANDING AND FOLLOWING PROPER **Bailey, Babcock & Wilcox** INSTRUCTIONS AND MANUALS. OTHERWISE INJURY OR DAMAGE MAY RESULT.

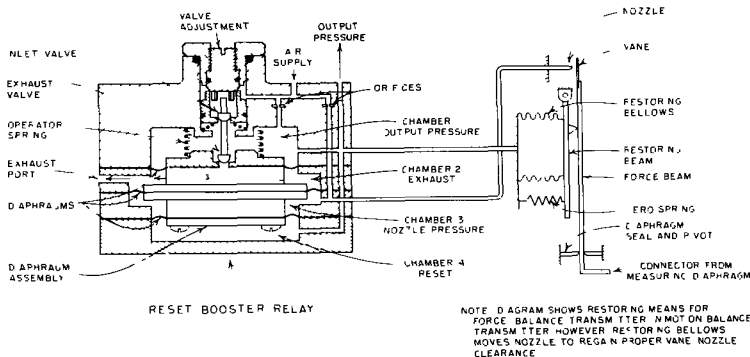

FIGURE 1 Operating Diagram of Booster Relay in Force Balance Transmitter

## OPERATION

A schematic operating diagram of the Reset Booster Relay is shown in Figure 1.

Three diaphragms divide the inside of the unit into four air pressure chambers. The diaphragms move together since they are clamped at their centers by the diaphragm assembly. Since chambers 1 and 4 are connected and are equal in effective diaphragm area, their opposing forces on the diaphragm assembly balance out. Chamber 2 is open to atmosphere. The operator spring exerts a force downward on the diaphragm assembly. Thus, since chamber 3 pressure exerts a force upward, the position of the diaphragm assembly is a direct function of chamber 3 pressure.

Supply air enters chamber 3 and the nozzle thru a pressure reducing orifice. The rate of air flow from the nozzle determines the magnitude of the pressure in chamber 3. At balance, this pressure is about 2 psig, which is the pressure required to balance the downward force of the operator spring.

When the measured variable increases, linkage from the measuring element moves the vane closer to the nozzle tip, retarding the flow of air from the nozzle and increasing the pressure in chamber 3. The pressure increase moves the diaphragm assembly up, opening the inlet valve and closing the exhaust valve. Supply air enters chamber 1 thru the inlet valve, causing the output pressure of the Booster Relay to begin to increase.

Chamber 1 pressure is also applied to the restoring bellows. As the pressure increases, the restoring bellows extends, moving the vane away from the nozzle. The resultant increased rate of air flow from the nozzle causes the pressure in chamber 3 to begin to decrease.

Chamber 1 pressure will continue to increase until the vane is restored to that position with respect to the nozzle which produces a pressure of 2 psig in chamber 3. The oper-

ator spring by then has moved the diaphragm assembly down to its original position, closing the inlet valve and causing the Booster Relay output pressure to stabilize at the new, increased value.

When the measured variable decreases, the operation of the Booster Relay as described above is reversed. The vane moves away from the nozzle, decreasing the pressure in chamber 3 below 2 psig. The operator spring moves the diaphragm assembly down, opening the exhaust valve and permitting the output pressure to begin to decrease thru chamber 1. As the pressure in the restoring bellows decreases, the bellows and consequently, the restoring beam begin to retract. The force beam, following the restoring beam, moves the vane closer to the nozzle, increasing the pressure in chamber 3. Chamber 1 pressure will continue to decrease until the vane is restored to that position with respect to the nozzle which produces a pressure of 2 psig in chamber 3. The diaphragm assembly by then has been restored to its original position, with the inlet valve closed and Booster Relay output pressure stabilized at the new, decreased value.

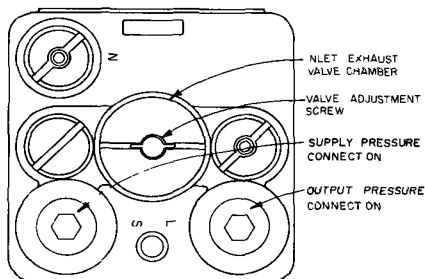

FIGURE 2 - Output and Supply Connections

Note that supply air also enters chamber 1 thru a pressure-reducing orifice. When the Relay is at balance, the bleed of air thru this orifice maintains the pressure in chamber 1 slightly above that value required to permit the diaphragm assembly to seat positively against the exhaust valve. The exhaust valve is thus maintained in a "floating" position to facilitate the instrument's speed of response to a change in input.

### ROUTINE SERVICING

1. Periodically inspect nozzle tip (Figure 3) and vane (on associated instrument) for deposits of oil, dirt, etc. Clean with a suitable solvent.
2. Periodically replace felt pad air filters as follows:
  - a. Turn OFF supply air to Booster Relay and disconnect supply air and output lines from Booster (Figure 2).
  - b. Remove wire mesh discs (Item 2, Figure 5) and felt pads (Item 8). This is most easily accomplished with a pick.
  - c. Replace felt pads. Replace wire mesh discs.

NOTE: When replacing mesh discs, make certain there is a disc under felt pad in supply connection

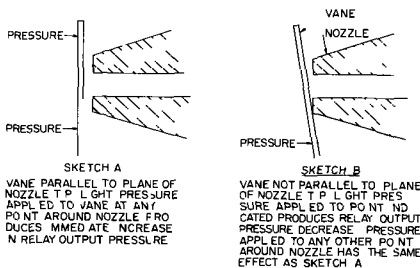

FIGURE 3 Vane and Nozzle Alignment

- d. Reassemble supply air and output lines to Booster unit. Then turn ON supply air to Booster Relay.

## CORRECTIVE MAINTENANCE

If the Booster Relay is not operating satisfactorily, make the checks and adjustments as outlined in the Fault Correction Chart. Refer to the specific subheading for replacement of parts.

If the Booster Relay still does not operate properly after corrective maintenance, it is recommended that the unit be returned to the factory for repair, since realignment of the diaphragm clamping assembly and the required recalibration is extremely critical.

### Fault Correction Chart

Booster Fault	Probable Cause	Corrective Action
1. Booster unit output pressure does not immediately increase when flow of air is blocked.	<ul style="list-style-type: none"> <li>a. Clogged nozzle orifice</li> <li>b. Leakage around sections of Booster casing</li> <li>c. Dirty filters</li> <li>d. Booster calibration incorrect</li> </ul>	<ul style="list-style-type: none"> <li>a. Depress orifice cleanout plungers. WARNING Do not depress plunger if Type AF is used with a selector station, unless station is in manual operation.</li> <li>b. Torque four screws clamping Booster sections together to 30 in lb.</li> <li>c. Remove and replace filters.</li> <li>d. Check Booster calibration (see 'Calibration' on page 5).</li> </ul>
2. Booster output sluggish or output increases then drops to zero when flow of air is blocked.	<ul style="list-style-type: none"> <li>a. Internal leakage</li> <li>b. Dirty filters</li> </ul>	<ul style="list-style-type: none"> <li>a. Replace Booster Relay.</li> <li>b. Remove and replace filters.</li> </ul>
3. Booster unit output pressure does not immediately decrease when vane is pulled away from nozzle.	<ul style="list-style-type: none"> <li>a. Blocked air line from Booster unit to nozzle.</li> <li>b. Booster calibration incorrect</li> <li>c. Internal leakage</li> </ul>	<ul style="list-style-type: none"> <li>a. Remove line and clean.</li> <li>b. Check Booster calibration (see 'Calibration' on page 5).</li> <li>c. Replace Booster Relay.</li> </ul>

Reset Booster Relay

**CALIBRATION**

The Reset Booster Relay has only one adjustment. The valve adjustment, shown in Figures 1 and 2, adjusts the inlet valve seat to balance the effective areas of the chamber 1 and chamber 4 diaphragms to obtain an even reset rate. This adjustment is sealed with a drop of Loctite cement (Grade C) after factory calibration. Do not change the setting of this adjustment unless absolutely necessary. If the Relay has been disassembled, or if the setting of the valve adjustment has been changed for any reason, check the calibration of the unit as outlined below.

1. Remove Booster Relay from transmitter.
2. Attach calibration block to Relay using screws removed in step 1, and connect in calibration setup as shown in Figure 4. Connect mercury manometer to Booster Relay output pressure connection. Connect another mercury manometer to tee fitting in piping to input connection of calibrator block.
3. Apply supply pressure of 18 psi (for 3 15 psig output range) or 30 psi (for 3-27 psig output range) to Booster Relay supply Pressure connection.

4. Slowly apply about 2 psi to calibration block input connection to simulate nozzle back pressure. Note value of pressure, on nozzle back pressure manometer, which causes output pressure to increase at a constant rate. Slowly reduce nozzle back pressure and note pressure which causes output pressure to decrease at a constant rate.

a. If rate of output pressure rise slows down (decelerates) turn valve adjustment screw clockwise a small amount

b. If rate of output pressure rise speeds up (accelerates) turn adjustment screw counter-clockwise a small amount.

5. Repeat step 4 above until output pressure changes at a constant rate. The difference between the nozzle back pressure which causes a constant rise and that which causes a constant drop should be about 0.1 psi and should occur between 1.6 psi and 2.5 psi.

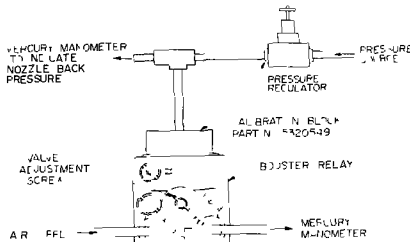

CALIBRATION BLOCK 5320549 1

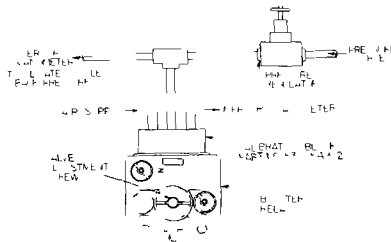

CALIBRATION BLOCK 5320549 2

**FIGURE 4** Calibration Setup with Calibration Blocks

6. If Booster Relay cannot be calibrated as described above, fault may be caused by leakage. Refer to "Corrective Maintenance," to check Booster Relay for leakage.

## REPLACEMENT PARTS

### Spare Parts Kit

The Spare Parts Kit shown in Figure 5 should be carried in stock. Specify the Spare Parts Kit part number to order a complete kit.

### Ordering Individual Parts

Figure 5 is a Parts Drawing for the Reset Booster Relay, Part No. 5319700-□. This drawing will normally apply to the unit furnished. However, there may be individual differences in specific assemblies because of

a. Design changes made since the printing of this Instruction Section, or

b. Special design of equipment furnished to make it suitable for a special application.

Therefore, when ordering parts, assure receipt of correct replacements by specifying on the order

1. The complete part number (stamped on instrument nameplate) and code label number of instrument for which parts are desired

2. The Parts Drawing on which each part is illustrated (The Parts Drawing Number is given in the Figure caption.)

ITEM	PART NO	NAME
1	SEE NOTE 1	CODE LABEL
2	5320413	1 WIRE MESH 4 REQD
3	5316478	1 ORIFICE CLEANOUT ASSY 2 REQD
4	5316464	4 ORIFICE ASSY
5	5311428	11 O RING 2 REQD
6	5311428	2 O RING 2 REQD
7	5316464	1 ORIFICE ASSY
8	5320414	1 FELT PAD, 2 REQD
9	195104	1 PLUG 2 REQD (PT NO 5319700 5 ONLY)

NOTE 1 SPECIFY NUMBER ON CODE LABEL WHEN ORDERING PARTS  
NOTE 2 ITEMS 2 THRU 9 IN THE QUANTITIES LISTED ARE AVAILABLE AS SPARE PARTS KIT PT NO 256073 1 SPECIFY THIS NUMBER TO ORDER A COMPLETE KIT

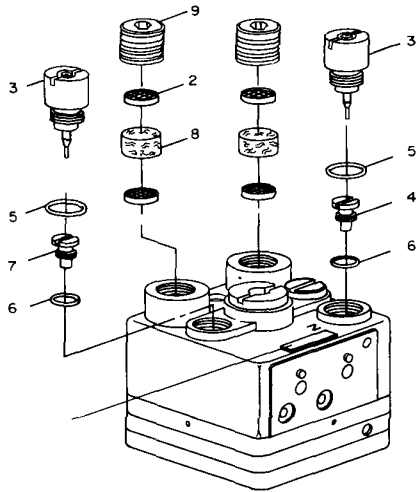

PART NO	FOR TYPE
5319700 1	KP23 RP11 RP12
5319700 3	BB, BE BR CA CB, CC, CE DC KM LH LU, PG WM EA
5319700 5	ADC AD5 AF5 KD14

FIGURE 5 - Parts Drawing P92 15, Booster Relay Assembly, Pt No. 5319700-□

## **Product Warranty**

Bailey Meter Company warrants the products manufactured by it to be free from defects in material and workmanship and will repair or replace, at its option, free of charge, f o b its factory, such part or parts which prove defective within one year from date of shipment. In respect to any products which are not an integral part of a product manufactured by the Company, the warranty given by the manufacturer thereof shall apply.

## **Shipping Damage**

We strongly recommend that you inspect and test your instrument as soon as you receive it. If the instrument is damaged or operates improperly, notify the carrier for inspection of the shipment. The carrier's claim agent will prepare a report of damage, a copy of which should be forwarded to your nearest Bailey District Office (see back cover for location). The District Office will then tell you how to have the instrument repaired or replaced.

## **Service**

The Bailey Meter Company is vitally concerned that your Bailey instrument provides continued, fine performance. This instruction manual is designed to fully describe the correct installation, operation, and maintenance of your instrument under recommended conditions. If the need arises, factory trained Service Engineers are on call for prompt, in plant maintenance. Telephone or wire your nearby Bailey District Office to make arrangements for this service.

## **Replacement Parts and Supplies**

Complete parts drawings and recommended spare parts kit information are included in this instruction manual. When replacement parts or supplies are required for maintenance of your Bailey instrument, contact your nearest Bailey District Office (see back cover for location). Always specify complete data on the instrument nameplate on your inquiry or order for parts. Common parts are available for shipment within 48 hours on a speed-order basis.

**BAILEY METER COMPANY  
HEADQUARTERS**  
Wickliffe, Ohio 44092

**U S A SALES OFFICES**

California Los Angeles  
California San Francisco  
Colorado Denver  
Connecticut, New Haven  
Florida, Jacksonville  
Georgia Atlanta  
Illinois Chicago  
Kentucky, Louisville  
Louisiana, New Orleans  
Maine, Augusta  
Maryland, Baltimore  
Massachusetts Boston  
Michigan Detroit  
Michigan, Kalamazoo  
Minnesota, St. Paul  
Missouri, Kansas City  
Missouri, St. Louis  
North Carolina, Charlotte  
New Jersey, East Orange  
New York, Buffalo  
New York, Syracuse  
Ohio, Cincinnati  
Ohio, Cleveland  
Pennsylvania, Philadelphia  
Pennsylvania, Pittsburgh  
Texas, Dallas  
Texas, Houston  
Virginia, Richmond  
Washington, Seattle  
Wisconsin, Milwaukee

**BAILEY METER COMPANY LIMITED  
POINTE CLAIRE 730, QUEBEC**

Alberta, Edmonton  
British Columbia, Vancouver  
Manitoba, Winnipeg  
Nova Scotia, Halifax  
Ontario, Ottawa  
Ontario, Toronto  
Quebec, Montreal

**BAILEY METER AUSTRALIA PTY LTD  
REGENTS PARK, N.S.W. 2143**

N.S.W., Sydney  
Queensland, Brisbane  
South Australia, Adelaide  
Victoria, Melbourne  
Western Australia, Perth

**BAILEY JAPAN COMPANY LTD  
511-1 BARAKU N. RAYAMA CHO TAGATA GUN  
SHIZUOKA KEN JAPAN**

**INTERNATIONAL REPRESENTATIVES**

Argentina, Buenos Aires  
Brazil, Rio de Janeiro  
Chile, Santiago  
England, Croydon  
France, Paris  
India, New Delhi  
Italy, Milan  
Japan, Tokyo  
Mexico, Mexico City, D.F.  
Puerto Rico, San Juan  
Spain, Madrid  
Taiwan, Taipei  
Turkey, Ankara  
And Other Provinces, Cities

**Bailey**

a subsidiary of Babcock & Wilcox U.S.A.