

TBI

**PRODUCT
INSTRUCTION**

Type TB82TE

**Advantage Series™
Two-Wire, Two-Electrode
Conductivity/Concentration Transmitter**

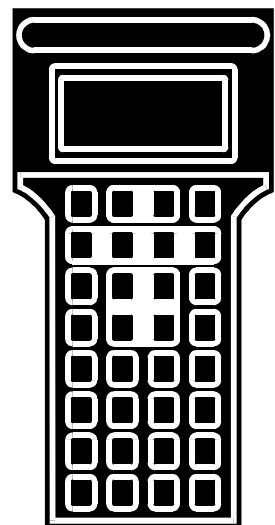
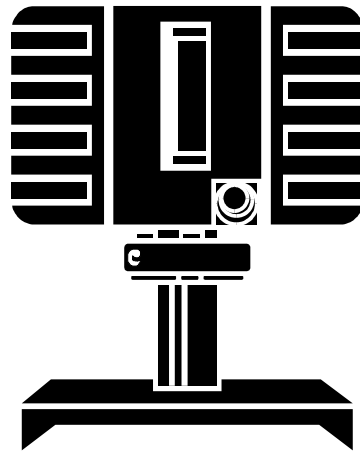
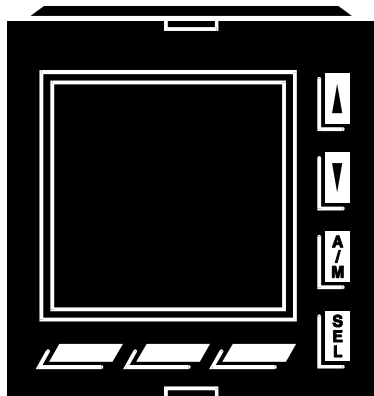
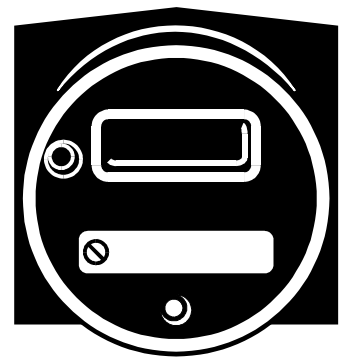
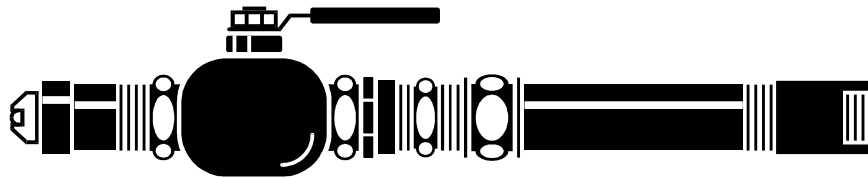

ABB

Preface

This publication is for the use of technical personnel responsible for installation, operation, maintenance, and repair of the TBI[®] Type TB82TE Advantage Series[™] Two-Wire, Two-Electrode Conductivity/Concentration Transmitter.

The Type TB82TE transmitter is delivered with default hardware and software configurations. These settings may need to be changed depending on the application requirements.

Some sections of this instruction have been prepared in procedure format. There is a sequence flowchart or table that follows the introduction to the section and any nonprocedural information. This flowchart directs personnel to the appropriate procedure located in the back of this instruction. By treating each task as a separate entity, the procedures provide an easy method for finding the information needed to perform each task.

The procedures have check boxes in the margin by each step. When performing a procedure, check each box as each step is completed.

It is important for safety and operation that this instruction be read and understood before attempting anything related to installation, operation, maintenance, or repair.

List of Effective Pages

Total number of pages in this instruction is 150, consisting of the following:

Page No.	Change Date	Page No.	Change Date
Preface	Original	PR9-1 through PR9-2	Original
List of Effective Pages	Original	PR10-1	Original
iii through x	Original	PR11-1 through PR11-4	Original
1-1 through 1-9	Original	PR12-1	Original
2-1 through 2-3	Original	PR13-1	Original
3-1 through 3-4	Original	PR14-1	Original
4-1 through 4-4	Original	PR15-1	Original
5-1 through 5-3	Original	PR16-1 through PR16-3	Original
6-1 through 6-4	Original	PR17-1 through PR17-3	Original
7-1 through 7-2	Original	PR18-1	Original
8-1 through 8-6	Original	PR19-1 through PR19-2	Original
9-1 through 9-2	Original	PR20-1 through PR20-4	Original
10-1 through 10-2	Original	PR21-1 through PR21-2	Original
11-1 through 11-2	Original	PR22-1 through PR22-4	Original
12-1 through 12-8	Original	PR23-1 through PR23-4	Original
13-1 through 13-2	Original	PR24-1	Original
14-1 through 14-2	Original	PR25-1 through PR25-2	Original
15-1 through 15-2	Original	PR26-1 through PR26-2	Original
A-1 through A-3	Original	PR27-1 through PR27-2	Original
B-1	Original	PR28-1	Original
C-1 through C-4	Original	PR29-1	Original
Worksheet 1	Original	PR30-1	Original
PR Index-1 through PR Index-2	Original	PR31-1	Original
PR1-1 through PR1-2	Original	PR32-1 through PR32-2	Original
PR2-1 through PR2-2	Original	PR33-1	Original
PR3-1 through PR3-2	Original	PR34-1	Original
PR4-1 through PR4-2	Original	PR35-1	Original
PR5-1 through PR5-4	Original	PR36-1	Original
PR6-1 through PR6-2	Original	PR37-1	Original
PR7-1 through PR7-2	Original	Index-1 through Index-4	Original
PR8-1 through PR8-2	Original		

When an update is received, insert the latest changed pages and dispose of the superseded pages.

NOTE: On an update page, the changed text or table is indicated by a vertical bar in the outer margin of the page adjacent to the changed area. A changed figure is indicated by a vertical bar in the outer margin next to the figure caption. The date the update was prepared will appear beside the page number.

Table of Contents

	<i>Page</i>
SECTION 1 - INTRODUCTION	1-1
OVERVIEW	1-1
INTENDED USER.....	1-1
FEATURES.....	1-2
EQUIPMENT APPLICATION	1-2
INSTRUCTION CONTENT	1-3
HOW TO USE THIS INSTRUCTION	1-4
DOCUMENT CONVENTIONS	1-4
REFERENCE DOCUMENTS.....	1-4
NOMENCLATURE	1-5
SPECIFICATIONS	1-6
ACCESSORIES.....	1-9
SECTION 2 - DESCRIPTION AND OPERATION.....	2-1
INTRODUCTION.....	2-1
FUNCTIONAL OPERATION	2-1
USER INTERFACE	2-1
MODULAR ELECTRONICS	2-1
TEMPERATURE COMPENSATION	2-1
DAMPING.....	2-2
DIAGNOSTICS	2-2
Transmitter Diagnostics	2-2
Sensor Diagnostics	2-3
Spike Output	2-3
SECTION 3 - INSTALLATION	3-1
INTRODUCTION.....	3-1
UNPACKING AND INSPECTION	3-1
LOCATION CONSIDERATIONS	3-1
Hazardous Locations.....	3-2
Radio Frequency Interference.....	3-2
WIRING CONSIDERATIONS	3-3
OTHER EQUIPMENT INTERFACE	3-3
TRANSMITTER ROTATION	3-3
INSTALLATION SEQUENCE	3-3
SECTION 4 - OPERATING PROCEDURES.....	4-1
INTRODUCTION.....	4-1
OPERATOR INTERFACE CONTROLS	4-1
Liquid Crystal Display.....	4-1
Smart Keys	4-2
MODES OF OPERATION	4-3
HOLD ICON	4-4
FAULT ICON	4-4
SPIKE ICON	4-4
SECTION 5 - MEASURE MODE.....	5-1
INTRODUCTION.....	5-1
BOREDOM SWITCH.....	5-1
PRIMARY DISPLAY.....	5-1
SECONDARY DISPLAY	5-1

Table of Contents (continued)

	<i>Page</i>
<hr/>	
SECTION 5 - MEASURE MODE (continued)	
Fault Information Smart Key	5-1
Menu Smart Key.....	5-2
<hr/>	
SECTION 6 - CALIBRATION	6-1
INTRODUCTION	6-1
CALIBRATE STATES	6-1
CALIBRATION SEQUENCE	6-1
<hr/>	
SECTION 7 - OUTPUT/HOLD MODE	7-1
INTRODUCTION	7-1
OUTPUT/HOLD STATES OF OPERATION	7-1
<hr/>	
SECTION 8 - CONFIGURATION	8-1
INTRODUCTION	8-1
PRECONFIGURATION DATA REQUIRED	8-1
CONFIGURATION SEQUENCE.....	8-2
<hr/>	
SECTION 9 - SECURITY MODE	9-1
INTRODUCTION	9-1
SECURITY STATE.....	9-1
ENTERING PASSWORD	9-1
SECURITY SEQUENCE.....	9-1
<hr/>	
SECTION 10 - SECONDARY DISPLAY MODE	10-1
INTRODUCTION	10-1
SECONDARY DISPLAY STATES OF OPERATION.....	10-1
SECONDARY DISPLAY OPERATION.....	10-1
<hr/>	
SECTION 11 - UTILITY MODE	11-1
INTRODUCTION	11-1
FACTORY AND USER STATES	11-1
<hr/>	
SECTION 12 - DIAGNOSTICS AND TROUBLESHOOTING	12-1
INTRODUCTION	12-1
FAULT CODES	12-1
Problem Codes	12-1
Error Codes.....	12-5
CALIBRATION DIAGNOSTICS	12-6
ADDITIONAL DIAGNOSTICS	12-7
TROUBLESHOOTING SEQUENCE	12-7
<hr/>	
SECTION 13 - MAINTENANCE	13-1
INTRODUCTION	13-1
PREVENTIVE MAINTENANCE SCHEDULE.....	13-2

Table of Contents (continued)

	<i>Page</i>
SECTION 14 - REPAIR AND REPLACEMENT	14-1
INTRODUCTION	14-1
REPAIR AND REPLACEMENT SEQUENCE	14-1
SECTION 15 - SUPPORT SERVICES	15-1
INTRODUCTION	15-1
RETURN MATERIALS PROCEDURES	15-1
REPLACEMENT PARTS	15-1
RECOMMENDED SPARE PARTS KITS	15-2
APPENDIX A - TEMPERATURE COMPENSATION	A-1
INTRODUCTION	A-1
TEMPERATURE COMPENSATION TYPES	A-1
Standard KCl	A-1
Temperature Coefficient	A-2
User-Defined	A-3
Pure Water	A-3
APPENDIX B - CONCENTRATION PROGRAMMING	B-1
INTRODUCTION	B-1
USER-DEFINED CONDUCTIVITY-TO-CONCENTRATION CURVES	B-1
APPENDIX C - PROGRAMMING TEXT STRING GLOSSARY	C-1
INTRODUCTION	C-1
TEXT PROMPTS	C-1
FLOW TREE	C-4

List of Procedures

<i>No.</i>	<i>Title</i>
PR1 -	PIPE MOUNTING
PR2 -	PANEL MOUNTING
PR3 -	WALL MOUNTING
PR4 -	HINGE MOUNTING
PR5 -	WIRING AND GROUNDING
PR6 -	TEMPERATURE CALIBRATION
PR7 -	PV CALIBRATION
PR8 -	OUTPUT CALIBRATION
PR9 -	EDIT CALIBRATION
PR10 -	RESET CALIBRATION
PR11 -	OUTPUT/HOLD MODE
PR12 -	SELECTING VIEW OR MODIFY CONFIGURATION STATE
PR13 -	MODIFYING CONFIGURATION WHILE VIEWING
PR14 -	PROGRAMMING MODE CHANGE
PR15 -	ANALYZER AND SENSOR CELL CONSTANT TYPE SELECTIONS
PR16 -	CONCENTRATION PROGRAMMING

List of Procedures (continued)

<i>No.</i>	<i>Title</i>	<i>Page</i>
PR17 -	TEMPERATURE SENSOR AND COMPENSATION TYPE SELECTIONS	
PR18 -	TEMPERATURE COMPENSATION COEFFICIENT SETTING	
PR19 -	USER-DEFINED TEMPERATURE COEFFICIENT PROGRAMMING	
PR20 -	COMPLETING CONFIGURATION	
PR21 -	CONFIGURATION LOCKOUT	
PR22 -	SECURITY AND PASSWORD ASSIGNMENT	
PR23 -	UTILITY MODE	
PR24 -	SENSOR INSPECTION	
PR25 -	ELECTRONIC SENSOR TEST	
PR26 -	TRANSMITTER TROUBLESHOOTING WITHOUT SENSOR	
PR27 -	SENSOR CLEANING	
PR28 -	KEYPAD CLEANING	
PR29 -	FRONT BEZEL REMOVAL	
PR30 -	POWER SUPPLY PCB REMOVAL	
PR31 -	TWO-ELECTRODE CONDUCTIVITY INPUT PCB REMOVAL	
PR32 -	MICROPROCESSOR PCB REPLACEMENT	
PR33 -	TWO-ELECTRODE CONDUCTIVITY INPUT PCB INSTALLATION	
PR34 -	POWER SUPPLY PCB INSTALLATION	
PR35 -	FRONT BEZEL INSTALLATION	
PR36 -	REAR COVER REPLACEMENT	
PR37 -	SHELL REPLACEMENT	

List of Figures

<i>No.</i>	<i>Title</i>	<i>Page</i>
1-1.	Load Limits	1-9
3-1.	Transmitter Dimensions	3-2
3-2.	Transmitter Rotation	3-4
3-3.	Installation Sequence	3-4
4-1.	Liquid Crystal Display	4-2
5-1.	Operating Mode Screen Flow	5-3
6-1.	Calibrate Mode Screen Flow.....	6-3
6-2.	Calibration Sequence.....	6-4
7-1.	Output/Hold Mode Screen Flow	7-2
8-1.	Modify/View and Basic/Advanced States Screen Flow	8-2
8-2.	Modify Configure States Screen Flow	8-3
8-3.	Configuration Sequence.....	8-4
8-4.	Advanced Configuration Sequence.....	8-5
8-5.	Basic Configuration Sequence	8-6
9-1.	Security State Screen Flow	9-2
10-1.	Secondary Display Mode Screen Flow	10-2
11-1.	User State Screen Flow.....	11-2
12-1.	Troubleshooting Sequence.....	12-8
14-1.	Repair and Replacement Sequence	14-2
15-1.	Exploded View	15-2
C-1.	Function Flow Tree.....	C-4
PR1-1.	Pipe Mounting	PR1-2

List of Figures (continued)

<i>No.</i>	<i>Title</i>	<i>Page</i>
PR2-1.	Panel Mounting.....	PR2-2
PR3-1.	Wall Mounting	PR3-2
PR4-1.	Hinge Mounting	PR4-2
PR5-1.	Load Limits.....	PR5-2
PR5-2.	Wiring and Grounding	PR5-3
PR8-1.	Output Calibration Setup.....	PR8-2
PR16-1.	Linear Curve Fit.....	PR16-2
PR19-1.	User-Defined Temperature Compensation Curve.....	PR19-2
PR21-1.	Configuration Lockout Jumper.....	PR21-2
PR26-1.	Sensor Simulation Setup	PR26-1
PR30-1.	Power Supply PCB Removal	PR30-1
PR31-1.	Conductivity Input PCB Removal	PR31-1
PR32-1.	Microprocessor PCB Replacement	PR32-1

List of Tables

<i>No.</i>	<i>Title</i>	<i>Page</i>
1-1.	Reference Documents	1-5
1-2.	Nomenclature	1-5
1-3.	Specifications.....	1-6
1-4.	Accessory Kits.....	1-9
1-5.	Sensors.....	1-9
4-1.	Smart Key Functions	4-3
4-2.	Modes of Operation	4-4
5-1.	Engineering Units	5-1
6-1.	Calibrate States	6-1
7-1.	Output/Hold States	7-1
8-1.	Default Configuration	8-1
11-1.	User States	11-1
12-1.	Common Problem Codes	12-2
12-2.	Uncommon Problem Codes	12-3
12-3.	Error Codes	12-6
13-1.	Preventive Maintenance Schedule	13-2
15-1.	Spare Parts Kits	15-2
A-1.	Standard KCl Data Breakpoints	A-2
A-2.	Pure Water Coefficient Values	A-3
C-1.	Text Prompt Equivalents	C-1
PR5-1.	Sensor Connections	PR5-4
PR11-1.	Output Ranges.....	PR11-2
PR15-1.	Analyzer States	PR15-1
PR16-1.	Conductivity-to-Concentration Data.....	PR16-2
PR17-1.	Temperature Compensation States.....	PR17-2
PR19-1.	User-Defined Temperature Compensation Data.....	PR19-1
PR20-1.	Sensor Full Scale Measurement Ranges	PR20-1
PR23-1.	Default Configuration	PR23-2
PR26-1.	Sensor Simulation Values	PR26-2

Safety Summary



Electrostatic Sensitive Device

Devices labeled with this symbol and the equipment described in this instruction require special handling precautions. This equipment contains components that can be damaged from discharges of static electricity; therefore, avoid contact with terminal block conductors and electronic components on the circuit boards. Ordinarily, components will not be damaged if circuit boards are handled by the edges.

Refer to Electronic Industries Alliance (EIA) standard EIA-625, **Requirements for Handling Electrostatic-Discharge-Sensitive (ESDS) Devices** for detailed procedures on handling electronic components. This standard is the most comprehensive semiconductor ESD handling procedure in the industry.

GENERAL WARNINGS

Equipment Environment

All components, whether in transportation, operation or storage, must be in a noncorrosive environment.

Electrical Shock Hazard During Maintenance

Disconnect power or take precautions to insure that contact with energized parts is avoided when servicing.

SPECIFIC WARNINGS

Use this equipment only in those classes of hazardous locations listed on the nameplate. Uses in other hazardous locations can lead to unsafe conditions that can injure personnel and damage equipment. (p. 3-2)

All error conditions are considered catastrophic and require transmitter replacement. Replace the transmitter with a transmitter that is known to be operable. Leaving an inoperable transmitter in the process could cause process upsets. Some process upsets can lead to dangerous conditions that can harm personnel and damage equipment. (p. 12-6)

Allow only qualified personnel (refer to **INTENDED USER** in Section 1) to commission, operate, service, or repair this equipment. Failure to follow the procedures described in this instruction or the instructions provided with related equipment can result in an unsafe condition that can injure personnel and damage equipment. (p. 13-1)

Safety Summary (continued)

**SPECIFIC
WARNINGS
(CONTINUED)**

Do not substitute any components other than those listed in the appropriate procedures. Doing so will compromise the certification listed on the transmitter nameplate. Invalidating these certifications can lead to unsafe conditions that can injure personnel and damage equipment. (p. 14-1)

Do not disconnect equipment unless power has been switched off at the source or the area is known to be nonhazardous. Disconnecting equipment in a hazardous location with source power on can produce an ignition-capable arc that can injure personnel and damage equipment. (p. 14-1)

Consider the material compatibility between cleaning fluids and process liquids. Incompatible fluids can react with each other causing injury to personnel and equipment damage. (p. PR27-1)

Acids and bases can cause severe burns. Use hand and eye protection when handling. (p. PR27-1)

Use solvents only in well ventilated areas. Avoid prolonged or repeated breathing of vapors or contact with skin. Solvents can cause nausea, dizziness, and skin irritation. In some cases, overexposure to solvents has caused nerve and brain damage. Solvents are flammable - do not use near extreme heat or open flame. (p. PR27-1)

Trademarks and Registrations

Registrations and trademarks used in this document include:

- ™ Advantage Series Trademark of Elsag Bailey Process Automation.
 - ® HART Registered trademark of HART Communication Foundation.
 - ® Mylar Registered trademark of E. I. DuPont de Nemours Company, Incorporated.
 - ® TBI Registered trademark of Elsag Bailey Process Automation.
 - ® LADISH Registered trademark of LADISH Company.
 - ® TRI-CLAMP Registered trademark of LADISH Company.
-

SECTION 1 - INTRODUCTION

OVERVIEW

The Type TB82TE Advantage Series™ Two-Wire, Two-Electrode Conductivity/Concentration Transmitter is an advanced, microprocessor-based, two-wire, four to 20-milliampere compatible transmitter. It features internal and external diagnostic functionality, an innovative user interface with flexible smart key design, two user-selectable modes of operation, and DIN size packaging.

Diagnostic checks on the internal circuitry and external sensor are done continuously. This insures accuracy and immediate problem notification. Detection of sensor integrity includes: sensor polarization, process and temperature variable over or under range, and incorrect calibration values. The transmitter can be programmed to produce, on the output current, a repetitive modulation of a given magnitude when these diagnostic conditions occur.

The transmitter packaging conforms to DIN standards. Mounting options accommodate pipe, wall, hinge, and panel installations.

Changing the transmitter sensing capability to other analytical properties such as four-electrode conductivity is quick and easy due to the modular design.

The user interface is an innovative, patent-pending technology that facilitates a smooth and problem-free link between the user and transmitter functionality. The programming structure and smart keys reduce programming difficulties by providing a toggle between basic and advanced functions.

INTENDED USER

Installation Personnel	Should be electricians or persons familiar with the NEC (National Electrical Code) and local wiring regulations. Should have strong backgrounds in installation of analytical equipment.
Application Technicians	Should have solid backgrounds in conductivity and concentration measurements, electronic instrumentation, and process control, and be familiar with proper grounding and safety procedures for electronic instrumentation.
Operators	Should have knowledge of the process and should read and understand this instruction before attempting any procedure pertaining to the operation of the transmitter.

Maintenance Personnel Should have backgrounds in electricity and be able to recognize shock hazards. Personnel must also be familiar with electronic process control instrumentation and have a good understanding of troubleshooting procedures.

FEATURES

Simple smart key menu programming (patent pending).

Exceptional design: Allows up to 30.5 meters (100 feet) between sensor and transmitter.

Superior accuracy in low conductivity and pure water applications.

Fully programmable isolated output.

Many modes of temperature compensation: Includes three for pure water.

Pt (platinum) 100, Pt 1000, and three kilohm Balco resistance temperature detector (RTD) temperature inputs.

Compatible with complete line of ABB Instrumentation two-electrode conductivity sensors.

Local and remote diagnostic alarming (patent pending).

Adjustable damping.

Hold output function.

Programmable security codes and hardware configuration lockout.

HART[®] communications compatibility (consult factory).

NEMA 4X/IP65 housing: Cast aluminum with polyurethane powder coat finish.

CE Mark.

Intrinsically safe and nonincendive design (certifications pending).

Autorange across three decades of conductivity: From 0.000 μ S/cm to 19.99 mS/cm full scale.

EQUIPMENT APPLICATION

Use the Type TB82TE transmitter anywhere conductivity or concentration measurements are desired.

INSTRUCTION CONTENT

Introduction	Provides product overview, physical description of product, possible applications, and description of instruction and how to use it. Contains list of reference documents on related equipment and subjects, nomenclature, comprehensive list of hardware performance specifications including applicable certification information, accessories, and compatible sensors.
Description and Operation	Provides short description on transmitter functionality.
Installation	Contains unpacking and inspection instructions, and location, safety, wiring and cabling considerations. Installation sequence flowchart directs installation personnel to appropriate installation procedures.
Operating Procedures	Addresses operator interface controls and their function. Lists mode of operation and transmitter condition icons and describes their functions.
Measure Mode	Describes normal transmitter mode of operation including primary and secondary display, fault information smart key, and menu smart key functions. Contains screen flow diagram.
Calibration	Provides information on sensor and transmitter calibration. Contains screen flow diagrams. Calibration sequence flowchart directs calibration personnel to appropriate calibration procedures.
Output/Hold Mode	Lists output/hold states of operation. Contains screen flow diagram. Directs personnel to proper output/hold mode procedure.
Configuration	Defines required actions to establish and program transmitter configuration. Contains screen flow diagrams. Configuration sequence flowcharts direct configuration personnel to appropriate configuration procedures.
Security Mode	Provides information about transmitter security codes. Contains screen flow diagram. Directs personnel to proper security and password procedure.
Secondary Display Mode	Provides information about secondary display that appears during measure mode. Contains screen flow diagram. Directs personnel to appropriate secondary display procedure.
Utility Mode	Defines reset options and basic/advanced programming toggle. Contains screen flow diagram. Directs personnel to proper utility mode procedure.
Diagnostics and Troubleshooting	Provides description of diagnostic tools available. Contains problem code and error code tables. Troubleshooting sequence

flowchart directs personnel to appropriate troubleshooting procedures.

Maintenance Provides preventive maintenance table that directs personnel to various maintenance procedures.

Repair and Replacement Contains repair and replacement sequence flowchart that directs repair personnel to proper repair and replacement procedures.

Support Services Provides list of replacement parts.

Appendix A Provides temperature compensation information.

Appendix B Provides information on concentration programming.

Appendix C Provides glossary of text prompts used in secondary display during transmitter programming.

Procedures Provide procedures for each task.

HOW TO USE THIS INSTRUCTION

Read this entire instruction in sequence before attempting to install, maintain, or repair the transmitter. After gaining a complete understanding of this instruction and the transmitter it can be used as a reference.

Some sections of this instruction have been prepared in procedure format. There are sequence flowcharts that direct personnel to the appropriate procedures. By treating each task as a separate entity, the procedures provide an easy method for finding the information needed to perform each task. The procedures can be removed and placed into separate folders or notebooks, or carried to the job site.

Each procedure lists the recommended tools to perform that procedure. Specific tool sizes are listed when required, such as Allen wrench size, socket size, wrench size, etc. Screwdrivers are listed as long or short when necessary.

DOCUMENT CONVENTIONS

This document uses standard text conventions to represent display items:

Display item Any item displayed on a screen appears as italic text. Example:

Running

REFERENCE DOCUMENTS

Table 1-1 lists ABB documents referenced in this instruction.

Table 1-1. Reference Documents

Number	Document
P-E21-001	Installing a 4 to 20 mA Transmitter in a Hazardous Location
WBPEEU110502A0	Type STT Smart Transmitter Terminal Instruction
WBPEEU520152A0	Advantage Series 2-Wire, 2-Electrode Conductivity/Concentration Transmitter Specification

NOMENCLATURE

Table 1-2 presents the transmitter nomenclature.

Table 1-2. Nomenclature

Position	5	6	7	8	9	10	11	12	13		
T	B	8	2	T	E	-	-	-	-	-	Advantage Series Transmitter
											Input
	P	H	-	-	-	-	-	-	-	-	pH/ORP/pION
	E	C	-	-	-	-	-	-	-	-	Four-electrode conductivity
	T	E	-	-	-	-	-	-	-	-	Two-electrode conductivity
	T	C	-	-	-	-	-	-	-	-	Toroidal conductivity
											Programming
			1	-	-	-	-	-	-	-	Basic
			2	-	-	-	-	-	-	-	Advanced
											Digital Communications
				0	-	-	-	-	-	-	None
				1	-	-	-	-	-	-	HART ¹
											Lightning Arrestor
					0	-	-	-	-	-	None
					1	-	-	-	-	-	Included
											Housing Type
						0	-	-	-	-	Powder coated, alodined aluminum
											Mounting Hardware
							0	-	-	-	None
							1	-	-	-	Pipe
							2	-	-	-	Hinge
							3	-	-	-	Panel
							4	-	-	-	Wall
											Agency Approvals
								0	-	-	None
								1	-	-	FM
								2	-	-	CSA
								3	-	-	CENELEC

Table 1-2. Nomenclature (continued)

Position	5	6	7	8	9	10	11	12	13	
T	B	8	2	T	E	-	-	-	-	Advantage Series Transmitter
										Label
										0 None
										1 Stainless steel
										2 Mylar®

NOTE:

1. This instruction covers the standard Type TB82TE transmitter. Consult factory for availability of HART version.

SPECIFICATIONS

Table 1-3 lists the transmitter specifications.

Table 1-3. Specifications

Property	Characteristic/Value
Type	2-wire, 2-electrode conductivity/concentration transmitter
Input types	
Conductivity and concentration	ABB Instrumentation Model TB2 2-electrode conductivity sensors
Temperature	Pt 100, Pt 1000, 3-kΩ Balco RTD
Process display range	
Conductivity	0.000 μS/cm to 19.99 mS/cm (temperature compensated)
Concentration	0.000 to 1,999 digits (engineering unit configurable)
Temperature display range	-20° to +300°C (-4° to +572°F)
Sensor full scale measurement range	
1.00 cell constant	0 to 19.99 mS/cm
0.10 cell constant	0 to 1,999 μS/cm
0.01 cell constant	0 to 199.9 μS/cm
Display resolution	
Conductivity	
1.00 cell constant	0.1 μS/cm
0.10 cell constant	0.01 μS/cm
0.01 cell constant	0.001 μS/cm
Concentration	0.001 digits (configuration dependent)
Temperature	1°C or 1°F
Accuracy	
Display	
Conductivity	±1.0% of measurement range per decade
Temperature	1°C
Output	±0.02 mA for output range set to full scale values

Table 1-3. Specifications (continued)

Property	Characteristic/Value						
Nonlinearity							
Display							
Conductivity	±1.0% of measurement range per decade						
Temperature	1°C						
Output	±0.02 mA for output range set to full scale values						
Repeatability							
Display							
Conductivity	±1.0% of measurement range per decade						
Temperature	1°C						
Output	±0.02 mA for output range set to full scale values						
Stability							
Display							
Conductivity	±2 LSD typical, ±5 LSD max.						
Temperature	1°C						
Output	±0.01 mA for output range set to full scale values						
Temperature compensation	Manual (0.1N KCl based) and automatic. Automatic configurable as: <table style="width: 100%; border: none;"> <tr> <td style="width: 70%;">Standard (0.1N KCl based)</td> <td>Pure water - neutral salt</td> </tr> <tr> <td>Coefficient (0 to 9.99%/°C adjustable)</td> <td>Pure water - trace acid</td> </tr> <tr> <td>User-defined</td> <td>Pure water - trace base</td> </tr> </table>	Standard (0.1N KCl based)	Pure water - neutral salt	Coefficient (0 to 9.99%/°C adjustable)	Pure water - trace acid	User-defined	Pure water - trace base
Standard (0.1N KCl based)	Pure water - neutral salt						
Coefficient (0 to 9.99%/°C adjustable)	Pure water - trace acid						
User-defined	Pure water - trace base						
Dynamic response	3 secs for 90% step change at 0.00-sec damping						
Ambient temperature effect at 95% relative humidity							
Conductivity	±0.1%/°C full scale, ±0.2%/°C displayed value						
Output	±0.01 mA/°C						
Output minimum span							
Conductivity							
1.00 cell constant	100.0 µS/cm						
0.10 cell constant	10.00 µS/cm						
0.01 cell constant	1.000 µS/cm						
Concentration	5% max. concentration range						
Output maximum span (full scale settings)							
Conductivity							
1.00 cell constant	19.99 mS/cm						
0.10 cell constant	1,999 µS/cm						
0.01 cell constant	199.9 µS/cm						
Concentration	1,999 digits						
Damping	00.0 to 99.9 secs						
Supply voltage							
Standard version	13 to 53 VDC (13 to 42 VDC for agency certified applications) ^{1,2}						
HART version	13.5 to 53 VDC (13.5 to 42 VDC for agency certified applications) ^{1,2}						
Load resistance range	Refer to Figure 1-1.						

Table 1-3. Specifications (continued)

Property	Characteristic/Value
Power supply effect	±0.005% of full scale span per volt
Turn on time	2 secs. typical, 4 secs. max.
Maximum sensor cable length	30.5 m (100 ft)
Sensor diagnostics	Polarization, PV/temp. over/under range, slope and offset check
Diagnostic notification	Local indication via <i>FAULT</i> or <i>SPIKE</i> icon
Analog mode	Programmable output pulse, 0.16 to 16 mA for 1 sec on 6-sec cycles
Environmental	
Temperature	
Operating	-20° to +60°C (-4° to +140°F)
LCD	-20° to +60°C (-4° to +140°F)
Storage	-40° to +70°C (-40° to +158°F)
Humidity	Will meet specifications to 95% RH (operating and storage)
Enclosure Classification	NEMA 4X/IP65
Mounting position effect	None
Size	½ DIN
h x w x d	144.0 by 144.0 by 171.0 mm (5.67 by 5.67 by 6.73 in.)
Minimum panel depth	144.8 mm (5.70 in.)
Maximum panel cutout	135.4 (+1.3, -0.8) by 135.4 (+1.3, -0.8) mm (5.33 (+0.05, -0.03) by 5.33 (+0.05, -0.03)) in.
Weight	1.9 kg (4.2 lb) without mounting hardware 3.4 kg (7.5 lb) with pipe mounting hardware
EMC requirements	CE certified - complies with all applicable European Community product requirements, specifically those required to display the CE marking on the product nameplate.
Electromagnetic emission - EN50081-2: 1994	EN55011: 1991 (CISPR11: 1990) Class A
Electromagnetic immunity - EN50082-2: 1996	EN61000-4-2: 1995, EN61000-4-3: 1997, EN61000-4-4: 1995, EN61000-4-8: 1994, ENV50141: 1994, ENV50204: 1996
Agency certifications ³	
Nonincendive (nonsparking)	
CSA	Class I; Division 2; Groups A, B, C, and D; Class II; Division 2; Groups E, F, and G; Class III; Division 2
FM	Class I; Division 2; Groups A, B, C, and D; Class II; Division 2; Groups F and G; Class III; Division 2
Intrinsic safety	When used with appropriate barriers per application guide <i>Installing a 4 to 20 mA Transmitter in a Hazardous Location.</i>
CENELEC	EEX ib, Zone 1; Group IIC, T4
CSA	Classes I, II, III; Division 1, Applicable Groups A, B, C, D, E, F, and G; T3C
FM	Classes I, II, III; Division 1; Applicable Groups A, B, C, D, E, F, and G; T3C

NOTES:

1. Add 0.5 VDC to all minimum voltage values when using lightning arrester option.
2. Add 1.0 VDC to all minimum voltage values when shorting jumper is removed from TEST terminals.
3. Hazardous location approvals for use in flammable atmospheres are for ambient conditions of -25° to +40°C (-13° to +104°F), 86 to 108 kPa (12.5 to 15.7 psi) with a maximum oxygen concentration of 21%.

SPECIFICATIONS ARE SUBJECT TO CHANGE WITHOUT NOTICE.

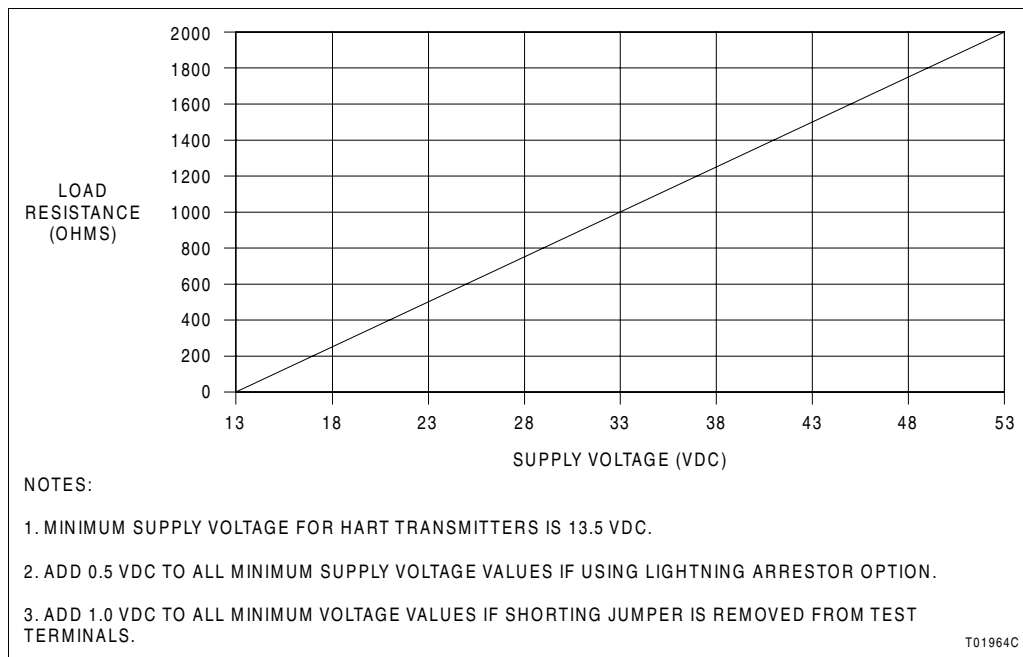

Figure 1-1. Load Limits

ACCESSORIES

Table 1-4 lists the accessory kits for the transmitter and Table 1-5 lists compatible sensors.

Table 1-4. Accessory Kits

Part Number	Description
1948385?1	Contains static-dissipative work surface (mat), ground cord assembly, wrist bands, and alligator clip for personnel working on devices containing semiconductor components.
4TB9515-0123	Panel mounting hardware
4TB9515-0124	Pipe mounting hardware
4TB9515-0125	Hinge mounting hardware
4TB9515-0156	Wall mounting hardware

Table 1-5. Sensors

Model	Fitting Type	Cell Constant
TB25	316 stainless steel sanitary/sterilizable	0.01, 0.10, 1.00
TB254	Inline twist lock, submersible	
TB256	Inline threaded, submersible	
TB26	Inline threaded, submersible ball valve insertion, hot tap	
TB27	High pressure hot tap	
TB28	LADISH® TRI-CLAMP® sterilizable	

SECTION 2 - DESCRIPTION AND OPERATION

INTRODUCTION

This section contains an overview of the functionality of the Type TB82TE transmitter.

FUNCTIONAL OPERATION

The Type TB82TE transmitter provides a four to 20-milliamperere output signal that is proportional to solution conductivity. The transmitter is compatible with all ABB Instrumentation two-electrode conductivity sensors.

USER INTERFACE

The user interface consists of a tactile keypad with four nondedicated smart keys and a custom LCD.

The LCD has a three and one-half digit numeric region that displays the PV, a six-character alphanumeric region that displays secondary information and programming prompts, and several status-indicating and programming icons.

Using a patent-pending novel approach, each of the four smart keys is located under a given set of icons. In each of the instrument modes and mode states, one icon over any given smart key illuminates and represents that smart key function. These smart key assignments vary as different programming modes and states are entered. In addition to the smart key assignments, text strings located in the six-character alphanumeric field (secondary display) are used as programming prompts.

MODULAR ELECTRONICS

The transmitter consists of three separate printed circuit board (PCB) assemblies that concentrate specific circuit functionality. This modular design allows for the ability to change the instrument from one of four types of instruments to another: pH/ORP/pION, four-electrode conductivity, two-electrode conductivity, and toroidal conductivity. In addition, instrument repair is made quick and easy by replacing the nonfunctioning PCB.

TEMPERATURE COMPENSATION

The process temperature is monitored using one of three types of RTD inputs: three-kilohm Balco, Pt 100, and Pt 1000. It is possible to program the secondary display to show the

temperature in degrees Celsius or degrees Fahrenheit when in the measure mode.

Temperature affects the activity of the disassociated ions in solution and hence the conductivity of that solution. Therefore, manual and automatic temperature compensation functions are available. Temperature compensation functions for conductivity and concentration configurations include manual (0.1N KCl based) and six types of automatic compensation routines. The automatic types are: standard (0.1N KCl based), coefficient (zero to 99.9 percent per degree Celsius adjustable), user-defined, pure water neutral salt, pure water trace acid, and pure water trace base.

DAMPING

Input damping can be adjusted from 00.0 to 99.9 seconds. This feature is useful in noisy process environments. It helps minimize the displayed PV and output current bounce.

Damping simulates a capacitive type lag where reaction to any signal change is slowed according to an entered time constant. For example, the output response to a step change in input reaches approximately 63.2 percent of its final value in five seconds for five seconds of damping.

DIAGNOSTICS

Diagnostics are provided for both the transmitter and sensor. Diagnostic detection of a serious condition that prevents the instrument from properly functioning enables a preset safe mode state. This configurable safe mode state forces the instrument output to be either high or low.

Some problems do not keep the instrument from functioning. A diagnostic spike output feature is used for these conditions. Once enabled, this feature modulates the output for one second out of every six seconds. The magnitude of these modulations can be set from one to 100 percent of the maximum output. Detection of over 40 problem conditions can be enabled.

In both cases, diagnostic conditions cause the *FAULT* and *FAULT info* icons on the display to energize. Interrogation of each fault condition is available using a single keystroke.

Section 12 provides diagnostics information.

Transmitter Diagnostics

Five critical errors in operation are monitored and linked to the safe mode feature. These conditions include: inoperable or incorrect input circuit, bad RAM, and damaged EE memory.

Sensor Diagnostics

The transmitter continually performs diagnostics on sensor integrity. When configured to do so, the *FAULT* and *FAULT info* icons and the spike output feature notify the operator of inconsistencies in sensor performance.

Sensor faults that activate the diagnostics are: polarization, shorted or open temperature sensor, high or low PV, high or low temperature, and many more.

Spike Output

Using the spike state in the configure mode initiates remote problem notification. The spike output option allows programming of a one to 100-percent (0.16 to 16-milliampere) pulse impressed on the four to 20-milliampere output for one second out of a six-second repeating cycle upon detection of a problem condition. Should the actual output of the transmitter be below 12 milliamperes, the pulse adds current; if above 12 milliamperes, it subtracts current.

SECTION 3 - INSTALLATION

INTRODUCTION

This section contains inspection instructions, and special location and safety considerations.

Following these topics is an installation sequence flowchart that guides personnel, seeking to perform a specific installation task, to the proper procedures to perform that task.

UNPACKING AND INSPECTION

Examine the equipment upon receipt for possible damage in transit. File a damage claim with the responsible transportation company if necessary and notify the nearest ABB Instrumentation sales office.

Carefully inspect packing material before discarding it to make sure that all mounting equipment and any special instructions or paperwork have been removed.

Use the original packing material and container for storage. The storage environment should be protected and free from extremes of temperature and humidity, and fall within the environmental constraints listed in Table 1-3.

NOTE: Remove the protective film from the transmitter lens after placing it in its final installed location.

LOCATION CONSIDERATIONS

When mounting the transmitter, leave ample clearance for removal of the front bezel and rear cover. Signal wiring should not run in conduit or open trays where power wiring or heavy electrical equipment could contact or interfere with the signal wiring. Use twisted, shielded pairs for best results.

Figure 3-1 shows the overall dimensions of the transmitter. Mounting hardware attaches to two or more of the four sets of threaded holes on the housing.

The transmitter design allows for panel mounting, pipe mounting, hinge mounting, or wall mounting. The installation site should be vibration free and conform to the environmental constraints listed in Table 1-3. Careful placement of the transmitter insures proper operation as well as overall safety.

NOTE: Temperature is an important consideration. Allow for adequate air flow, especially if installing the transmitter in an enclosed area.

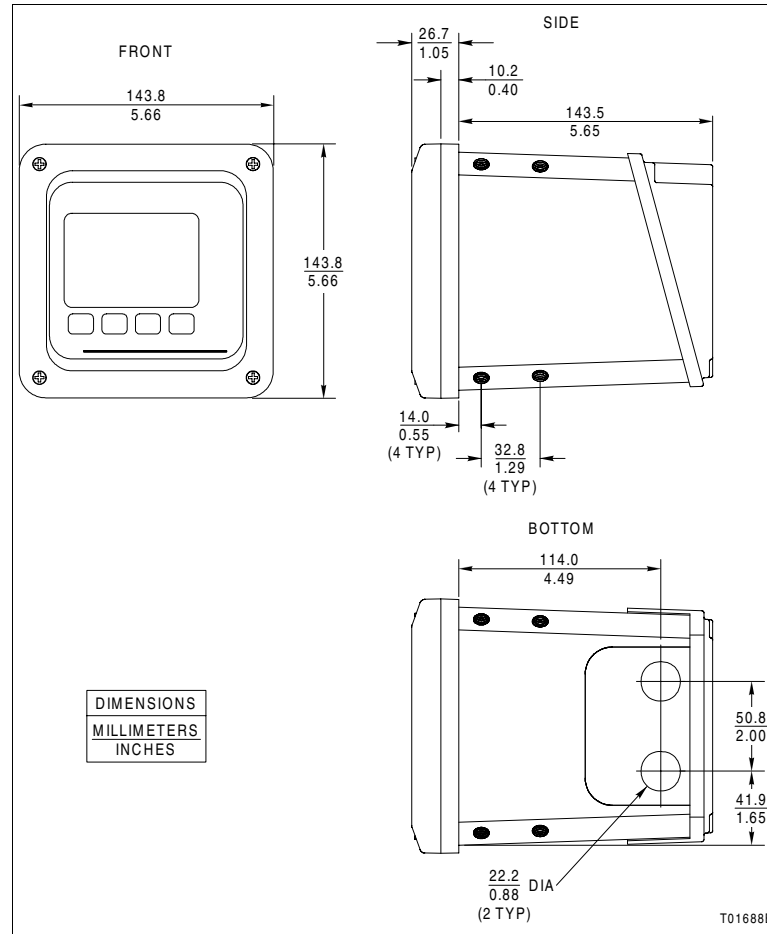

Figure 3-1. Transmitter Dimensions

Hazardous Locations

WARNING

Use this equipment only in those classes of hazardous locations listed on the nameplate. Uses in other hazardous locations can lead to unsafe conditions that can injure personnel and damage equipment.

Table 1-3 lists the agencies and types of hazardous location certifications for the transmitter.

Refer to **Installing a 4 to 20 mA transmitter in a hazardous location** for additional information when using equipment in a hazardous area.

Radio Frequency Interference

Most electronic equipment is influenced by radio frequency interference (RFI). Exercise caution with regard to the use of

portable communications equipment in the area. Post appropriate signs in the plant.

WIRING CONSIDERATIONS

NOTE: To prevent possible signal degradation, use a separate metal conduit run for both the sensor and signal/power wiring.

Transmitter power passes through the signal leads. Under ideal conditions, the use of conduit and shielded wire may not be required. However, to avoid noise problems, enclose the sensor and signal/power wiring in separate conduit. Just prior to entering the housing, terminate rigid conduit and install a short length of flexible conduit to reduce any stress to the housing.

Signal/power wiring must bear a suitable voltage rating, a temperature rating of 75-degrees Celsius (167-degrees Fahrenheit), and must be in accordance with all NEC requirements for the installation site.

OTHER EQUIPMENT INTERFACE

The transmitter has an isolated output and controls the loop current between four and 20 milliamperes depending on the range and PV values. Since the output is isolated, the instrument loop may have a maximum of one nonisolated device within its circuit. The maximum load on the current loop must not exceed the values shown in Figure 1-1.

TRANSMITTER ROTATION

The transmitter has four pairs of threaded mounting holes. Since these holes are located at the corners of the transmitter, it can be mounted in any of the four positions as shown in Figure 3-2.

INSTALLATION SEQUENCE

Refer to Figure 3-3 for the transmitter installation sequence. Each block of the flow represents a single task that must be completed before continuing with the sequence.

In some cases, more than one path can be taken during installation. For paths that are in parallel, either complete all of the tasks in all of the paths before continuing or complete all of the tasks in only those paths that apply before continuing. At least one path must be completed.

Some blocks contain alphanumeric codes. These codes identify the procedure that describes the steps to complete an

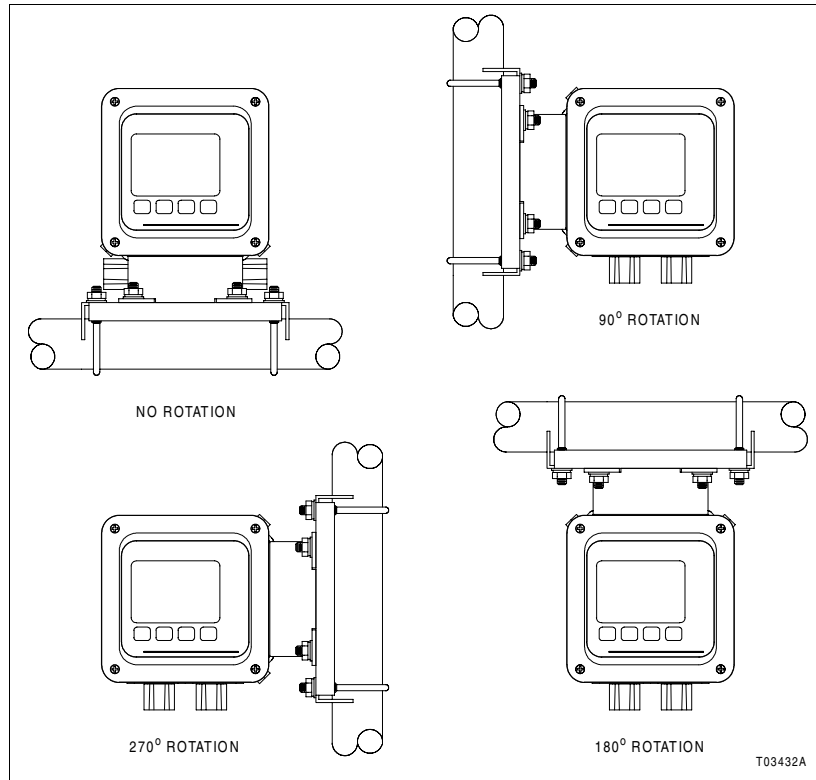

Figure 3-2. Transmitter Rotation

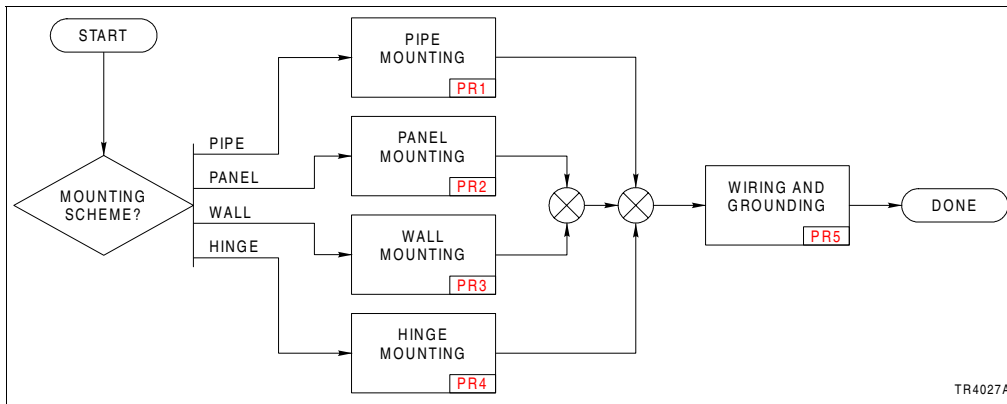

Figure 3-3. Installation Sequence

indicated task. Complete all of the steps given in a procedure before continuing to the next procedure.

The procedures have check boxes in the margin by each procedural step. When performing a procedure, check each box as each step is completed.

By treating each task as a separate entity, the procedures provide an easy method for finding the information needed to perform each task in the installation sequence.

SECTION 4 - OPERATING PROCEDURES

INTRODUCTION

The Type TB82TE transmitter has six main operating modes: measure, calibrate, output/hold, configure, security, and secondary display. An operating mode has several programming states that contain functions specific to that mode.

The transmitter has a built-in user interface through which all transmitter functions are programmed or monitored. In order to maximize the viewing area and minimize the space needed for the keypad, the patent-pending interface uses a custom LCD and four-button keypad. Instrument functions and programming prompts are available through two regions on the LCD. These regions include a primary area that shows the PV (conductivity) and a secondary area that displays text prompts for programming or auxiliary information.

In addition to the user friendly interface, the transmitter has a group of icons that alert the user of an existing fault condition, diagnostic spike output, or a held output. These icons, located at the top of the LCD, only appear under the specified condition. Pressing the *FAULT info* smart key while in the measure mode allows interrogation of any fault condition.

OPERATOR INTERFACE CONTROLS

The operator interface consists of the LCD and the smart keys.

Liquid Crystal Display

The LCD contains nine regions that provide information on the PV, engineering units, mode of operation, output hold condition, fault indication, secondary variable, and soft key assignments. A view of the full LCD with smart key and mode text included is shown in Figure 4-1.

The top set of icons indicates abnormal operating conditions such as the *Hold*, *Fault*, or *Spike* state. These icons only appear when the transmitter detects such a condition. They are active in all modes of operation.

The mode of operation indicators, shown as right arrows grouped next to the mode text, indicate the current mode of operation. Only one indicator is lit at a time. The appropriate indicator appears when moving from one mode to the other. The mode of operation indicators are active in all modes of operation.

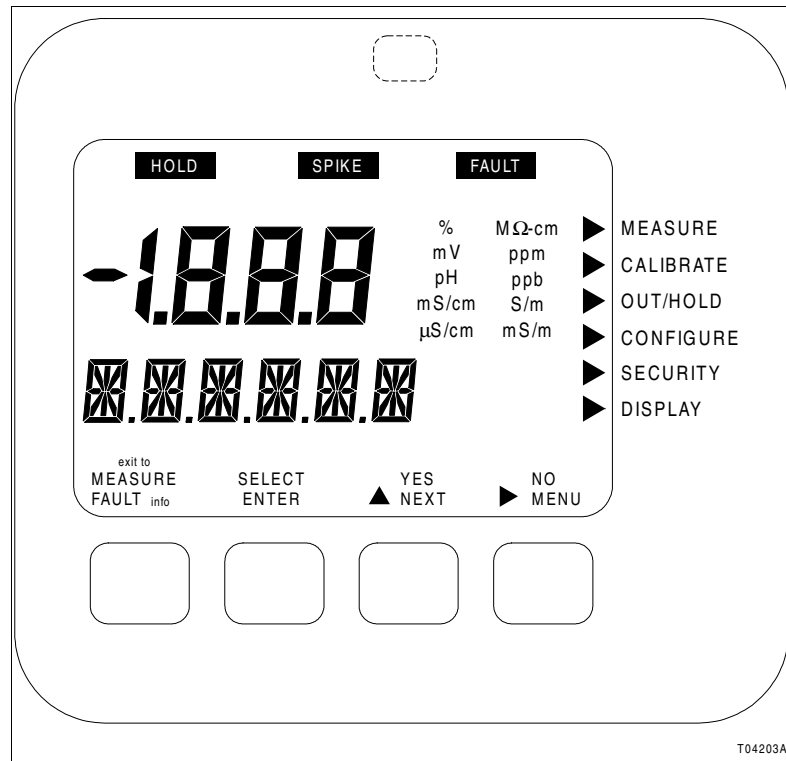

Figure 4-1. Liquid Crystal Display

The PV appears in the three and one-half digit, seven-segment region. This display region is supported by the engineering unit region. These regions are normally active in all modes of operation; however, some programming states use these regions for data entry.

The secondary variable is displayed in the six-character, 14-segment region. This display region displays secondary information and fault information in the measure mode and textual prompting in all other modes of operation. Due to the limited number of characters for this display region, much of the prompting takes the form of text abbreviations. Refer to [Appendix C](#) for programming text abbreviations. This region is active in all modes of operation.

The smart key assignments are grouped into four sets of icons, each group directly positioned above one of the four smart keys. These icons are textual representations of the function for the associated smart key. Only one assignment will appear per smart key at any given time.

Smart Keys

A five-button, tactile keypad is located on the front panel. The four buttons below the display are embossed to easily show

their location. A fifth hidden button, located at the center top of front panel, provides access to infrequently used functions.

The four embossed keys are called smart keys since their functions are dependent on the mode and state of the instrument. Since these four keys do not have a preassigned function, icons appear over the key to indicate its function. If a smart key does not have an icon above it, this smart key does not have a function and initiates no action when pressed. Using this smart key method, a reduced number of keys can be used without complicating instrument functionality.

Pressing the smart key initiates the displayed function of that smart key for each operating mode and state. For example, the *NEXT* function enables the cycling through of a series of programming states. The *SELECT* function enables entering into a given mode of operation or programming state. Using this method, the transmitter guides the user through the necessary steps to program or monitor the desired functions.

A general description of each smart key function is given in Table 4-1.

Table 4-1. Smart Key Functions

Icon	Function
ENTER	Stores configured items and alphanumeric data into permanent memory.
exit to MEASURE	Escapes to measure mode from all other modes and programming states. Not available in measure mode.
FAULT info	Accesses information on diagnostic problem or error conditions. Displays information as short text string and code. Only available in measure mode.
MENU	Increments through modes of operation.
NEXT	Increments through series of programming states.
NO	Denies action about to take place.
SELECT	Selects mode of operation or programming state shown in secondary display.
YES	Affirms action about to take place.
▼	Decrements numeric values or moves through a series of parameters.
▲	Increments numeric values or moves through a series of parameters.
▶	Steps to right moving from one digit to the next.

MODES OF OPERATION

The measure mode is the normal operating mode of the transmitter and is the default mode upon power up. The measure mode is the starting point for entry into other modes. Each mode contains a unique set of transmitter functions or states. These modes and their related functions are shown in Table 4-2.

Table 4-2. Modes of Operation

Mode	Function
Calibrate	Calibration of input and output functions.
Configure	Configuration of transmitter functions such as type of analyzer, cell constant, temperature compensation types, temperature sensor, damping, safe mode, diagnostics, etc.
Display	Selection of variable displayed in secondary display when in measure mode.
Measure	Display of process and secondary variables. Normal transmitter operating mode.
Output/hold	Online tuning of output parameters or manual setting of transmitter output. Useful during instrument maintenance, for example.
Security	Entering of password protection for calibrate, output/hold, and configure modes.

HOLD ICON

The *HOLD* icon appears when a hold condition is active. Holding the output can only be manually enabled. Manual activation is accessible in the output/hold mode of operation. In this mode, the hold state permits the output to be held at the captured level or at a manually set level.

FAULT ICON

The *FAULT* icon appears when the transmitter detects a fault condition. Fault conditions include all problem and error detection as outlined in [Section 12](#).

SPIKE ICON

When the transmitter detects a fault condition and has the spike output function enabled, the transmitter output begins to modulate and the *SPIKE* icon appears. This provides local and remote indication of a measurement loop fault condition. Refer to [Section 12](#) for more information on spike output and fault conditions.

SECTION 5 - MEASURE MODE

INTRODUCTION

The measure mode is the mode of operation upon transmitter power up and is the normal operating state of the transmitter. In this mode, the PV, output state, fault condition state, spike state, and secondary display information are displayed. All other modes of operation and fault information are accessible from the measure mode.

BOREDOM SWITCH

When any operating mode or state is entered and the measure mode is not returned to after the final step, the transmitter automatically returns to the measure mode of operation after 20 minutes of unattended use.

PRIMARY DISPLAY

The primary display shows the PV. The value of this variable is dependent on the configured analyzer, temperature compensation type, temperature value, sensor output, and damping value. The engineering units for the PV are dependent only on the configured analyzer (Table 5-1).

Table 5-1. Engineering Units

Analyzer Type	Engineering Unit
Concentration	parts per million (ppm), parts per billion (ppb), percent (%), user-defined
Conductivity	μ S/cm, mS/cm

SECONDARY DISPLAY

The secondary display has the ability to show a large array of information. Since the display area only has six characters, only one item can be shown at any given time. Typically, this region displays the process temperature in degrees Celsius. However, it can be changed to display the process temperature in degrees Fahrenheit, output current in milliamperes, sensor type, cell constant, conductivity value and solute name for a concentration analyzer, or firmware revision. Refer to [Section 10](#) for more information.

Fault Information Smart Key

Fault information is only accessible from the measure mode of operation. It is interrogated through the *FAULT info* smart key.

A fault condition causes the *FAULT* icon to blink and the *FAULT info* smart key to appear. These indicators continue to be present as long as the fault condition exists.

When pressing the *FAULT info* smart key, the faults appear in a first in, first out (FIFO) order and the first fault condition is shown in the secondary display. A short text string followed by the fault code is shown sequentially. Depressing the *FAULT info* smart key progressively moves from one fault to the next until all faults have been shown. Once all faults have been cycled through, the *FAULT* icon no longer blinks but remains on until removal of all fault conditions. If a new fault condition is detected, the *FAULT* icon begins to blink to indicate the newly detected condition. For more information on fault conditions and codes, refer to [Section 12](#) and its related procedures.

Menu Smart Key

The *MENU* smart key provides access to all other modes of operation. By pressing the *MENU* smart key, the transmitter moves from one mode of operation to the next. Visual feedback is provided in two manners: the mode indication arrow moves to the next mode, such as *CALIBRATE*, and the secondary display shows the text string representative of that mode, such as *CALIBR*. Access into the displayed mode of operation is allowed by pressing the *SELECT* smart key. The *exit to MEASURE* smart key provides an escape function to the measure mode.

As seen in the screen flow diagram shown in [Figure 5-1](#), pressing the *MENU* smart key when in the measure mode moves the transmitter into the calibrate mode. Once in the calibrate mode, pressing the *exit to MEASURE* smart key returns the transmitter back to the measure mode. Pressing the *SELECT* smart key moves the transmitter into the calibrate states of operation. Pressing the *MENU* smart key moves the transmitter to the output/hold mode. Use [Figure 5-1](#) to identify the smart key assignments and the resulting action.

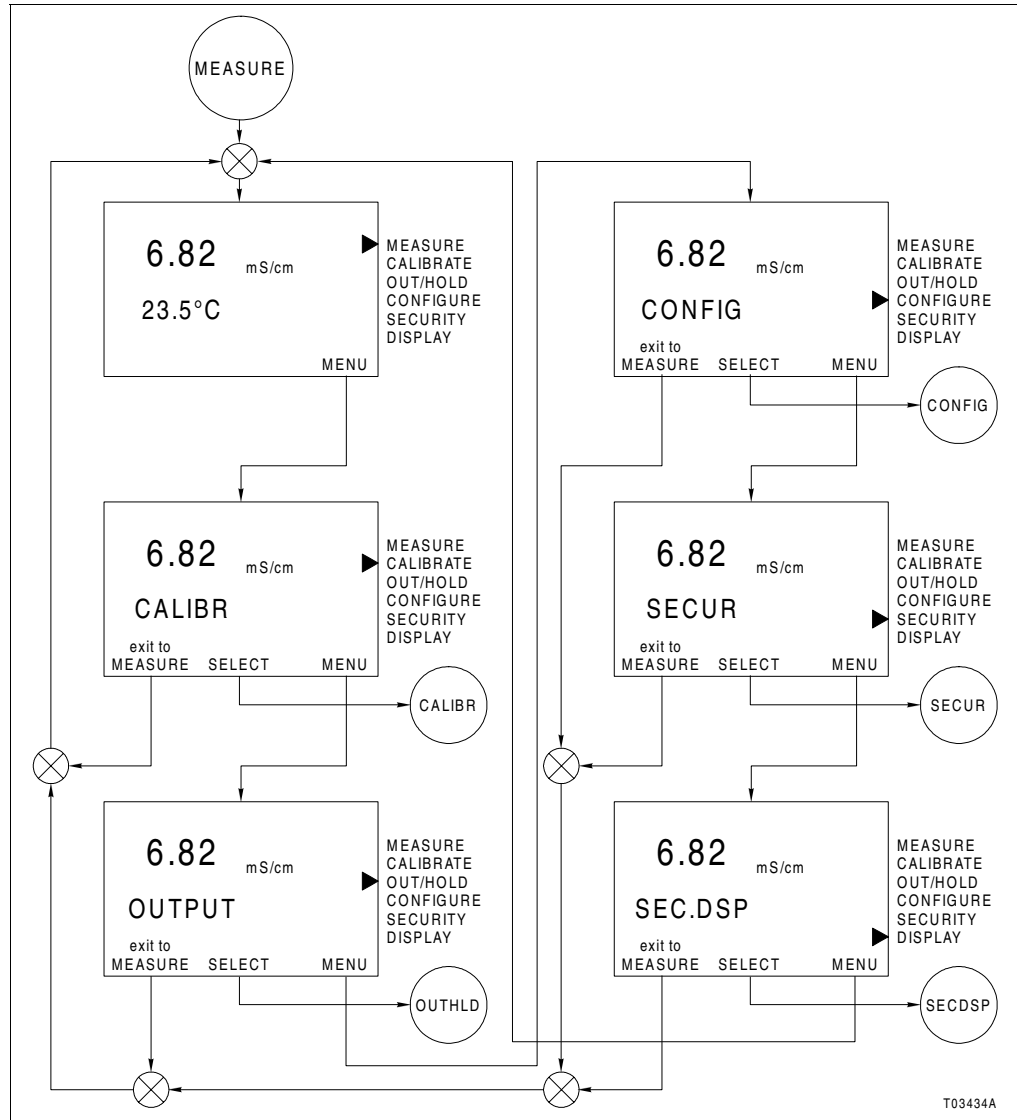

Figure 5-1. Operating Mode Screen Flow

SECTION 6 - CALIBRATION

INTRODUCTION

The calibrate mode provides the ability to calibrate the sensor input, temperature input, and transmitter output. These functions, referred to as calibrate states, include PV calibration, temperature calibration, edit calibration, reset calibration, and output calibration.

CALIBRATE STATES

The calibrate mode consists of five states. Table 6-1 describes the function of each state.

Table 6-1. Calibrate States

Calibrate State	Display	Description
Conductivity/ concentration	CON.CAL	Calibrate process sensor input via one-point smart calibration that adjusts offset, slope, or both based on sensor calibration history.
Edit	EDT.CAL	Manually adjust process sensor and temperature offset and slope values.
Output	OUT.CAL	Calibrate transmitter output values to measured values using external validation device.
Reset	RST.CAL	Restore calibration values for process sensor and temperature to factory settings.
Temperature	TMP.CAL	Calibrate temperature sensor input via one-point smart calibration that adjusts offset, slope, or both based on sensor calibration history.

When in the calibrate mode, pressing the *NEXT* smart key causes the display to sequentially move through each calibrate state. This cycle repeats until either selecting a calibrate state using the *SELECT* smart key or choosing the escape function by pressing the *exit to MEASURE* smart key.

Figure 6-1 is a screen flow diagram for the calibrate mode of operation.

CALIBRATION SEQUENCE

Refer to Figure 6-2 for the calibration sequence for the transmitter. Each block of the flow represents a single task that must be completed before continuing with the sequence.

In some cases, more than one path can be taken during calibration. For paths that are in parallel, either complete all tasks in all paths before continuing or complete all tasks in only those paths that apply before continuing. At least one path must be completed.

Some blocks contain alphanumeric codes. These codes identify the procedure that describes the steps to complete an indicated task. Complete all steps given in a procedure before continuing to the next procedure.

The procedures have check boxes in the margin by each procedural step. When performing a procedure, check each box as each step is completed.

By treating each task as a separate entity, the procedures provide an easy method for finding the information needed to perform each task in the calibration sequence.

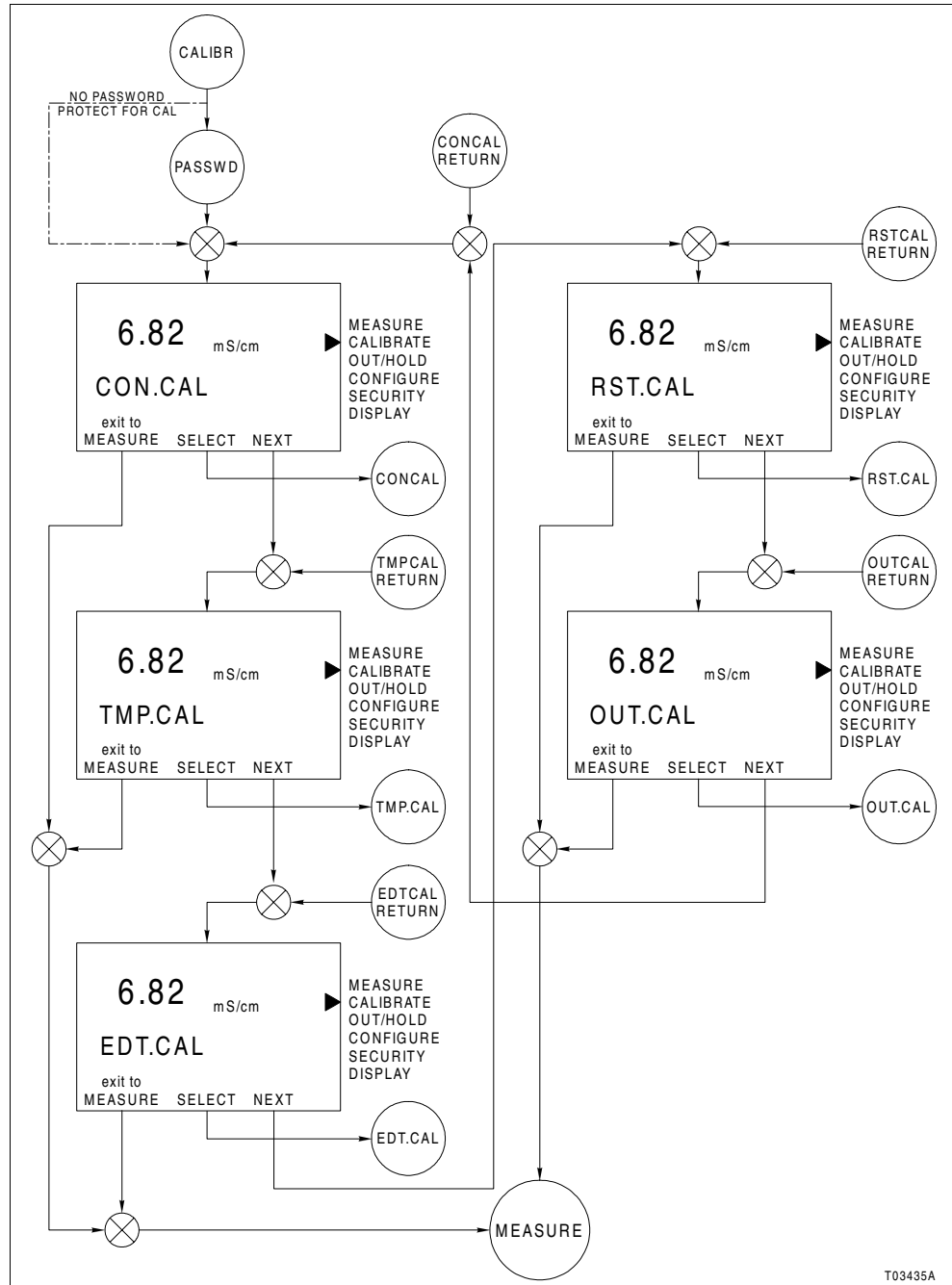

Figure 6-1. Calibrate Mode Screen Flow

T03435A

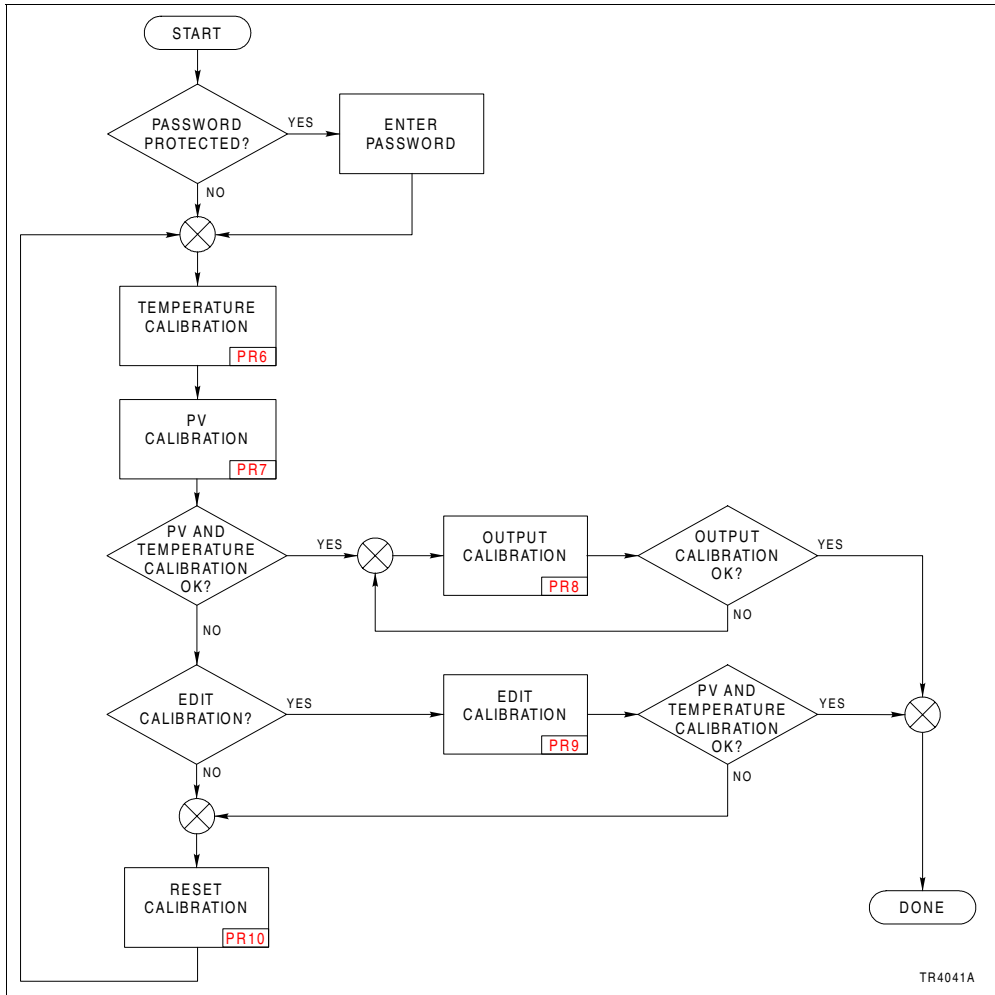

Figure 6-2. Calibration Sequence

SECTION 7 - OUTPUT/HOLD MODE

INTRODUCTION

The output/hold mode of operation provides the ability to set the output to a fixed level, change the output range, damp the output signal, or enable or disable the diagnostic spike.

OUTPUT/HOLD STATES OF OPERATION

When in the output/hold mode, pressing the *NEXT* smart key causes the display to move sequentially through each output/hold state. This cycle repeats until either selecting an output/hold state using the *SELECT* smart key or choosing the escape function by pressing the *exit to MEASURE* smart key.

The output/hold mode consists of five states of operation. Table 7-1 describes the function of each state of operation. There is only one procedure for the output/hold mode (PRI1). The procedure contains brief descriptions of each output/hold state. Figure 7-1 is a screen flow diagram for the output/hold mode of operation.

Table 7-1. Output/Hold States

State	Display	Function
Damping	<i>DAMPNG</i>	Reduces fluctuation in output signal.
Hold	<i>HOLD</i>	Fixes output level at value captured upon initiation of hold or at manually entered level.
Release hold	<i>REL.HLD</i>	Releases existing output/hold state.
Rerange	<i>RERANG</i>	Changes output range.
Spike	<i>SPIKE</i>	Enables or disables spike output function if configured.

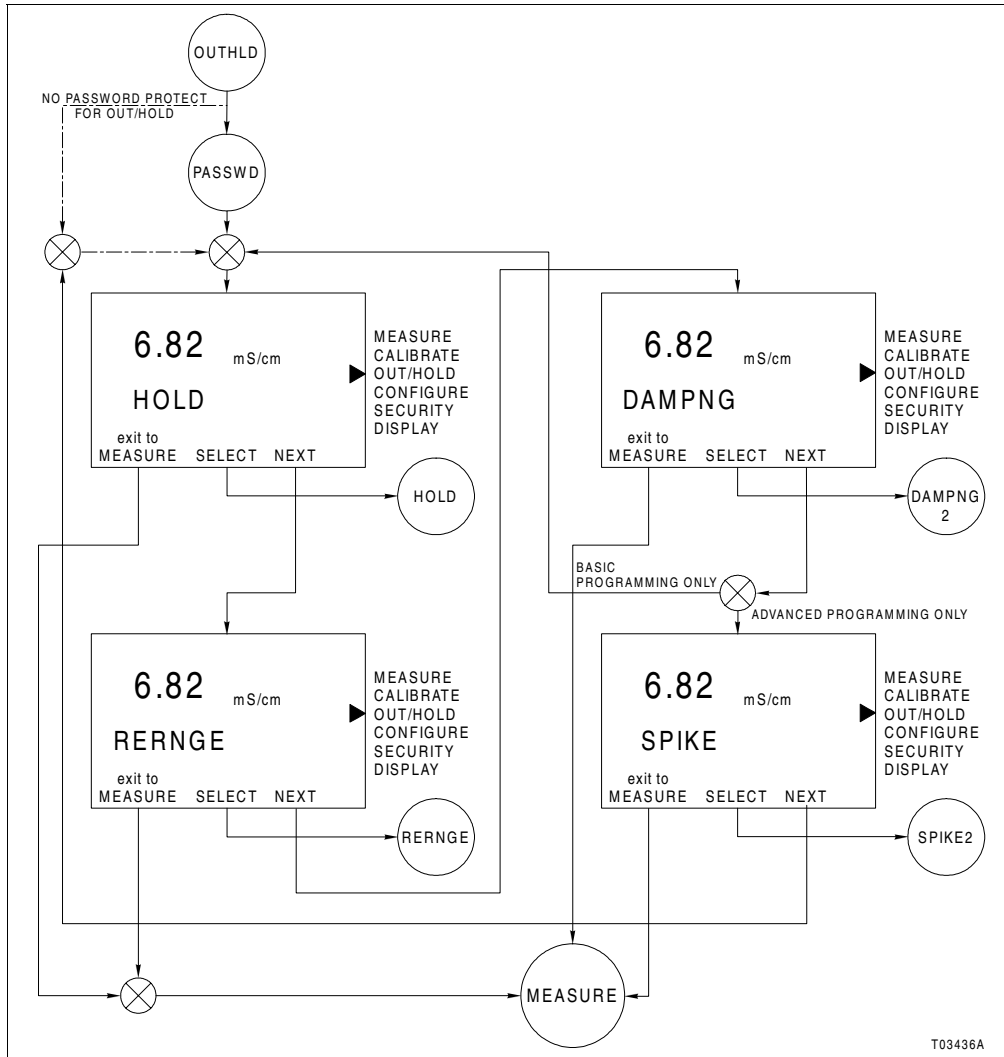

Figure 7-1. Output/Hold Mode Screen Flow

SECTION 8 - CONFIGURATION

INTRODUCTION

The configure mode of operation establishes the operating parameters of the transmitter. These parameters include: programming type, analyzer type, sensor cell constant, temperature compensation type, output range, damping value, diagnostic functionality, safe mode level, and spike magnitude. Table 8-1 lists the factory default configuration values.

Table 8-1. Default Configuration

Parameter	Setting
Instrument mode	Basic
Analyzer type	Conductivity, cell constant = 0.01
Temperature sensor type	Pt 1000
Temperature compensation type	Manual
Output range	0.00 to 199.9 μ S/cm
Damping value	00.5 sec
Sensor diagnostics	Disable
Safe mode failed output state	Low
Spike output ¹	0%
Hardware configuration lockout ²	Jumper position 1-2 - disable

NOTES:

1. Feature only available in advanced programming.

2. Refer to PR21 for procedure to change jumper position.

This section contains screen flow diagrams (Figs. 8-1 and 8-2). Refer to **CONFIGURATION SEQUENCE** for procedures needed to perform the configuration tasks. The procedures contain brief descriptions of the configure states of operation.

PRECONFIGURATION DATA REQUIRED

Before attempting to configure the transmitter, define the following:

- Analyzer parameters.
- Output range values.
- Security requirements.
- Sensor diagnostic functionality.

Use the worksheet at the end of these sections to help establish the proper settings for any given application. Use this worksheet during the configuration entry procedure and retain it as a historical record for future reference.

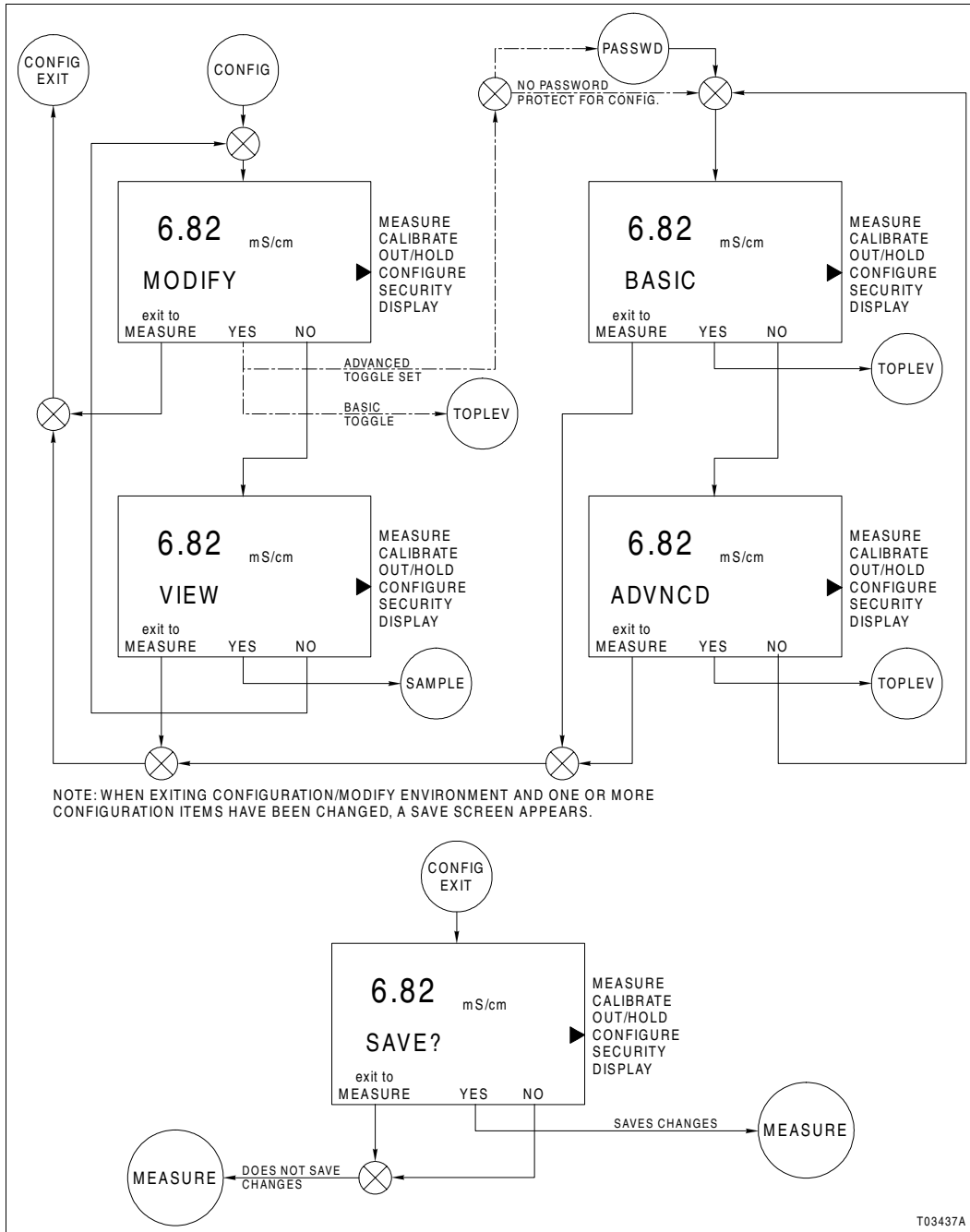

Figure 8-1. Modify/View and Basic/Advanced States Screen Flow

CONFIGURATION SEQUENCE

Refer to Figures 8-3, 8-4, and 8-5 for the transmitter configuration sequence. Each block of the flow represents a single task that must be completed before continuing with the sequence.

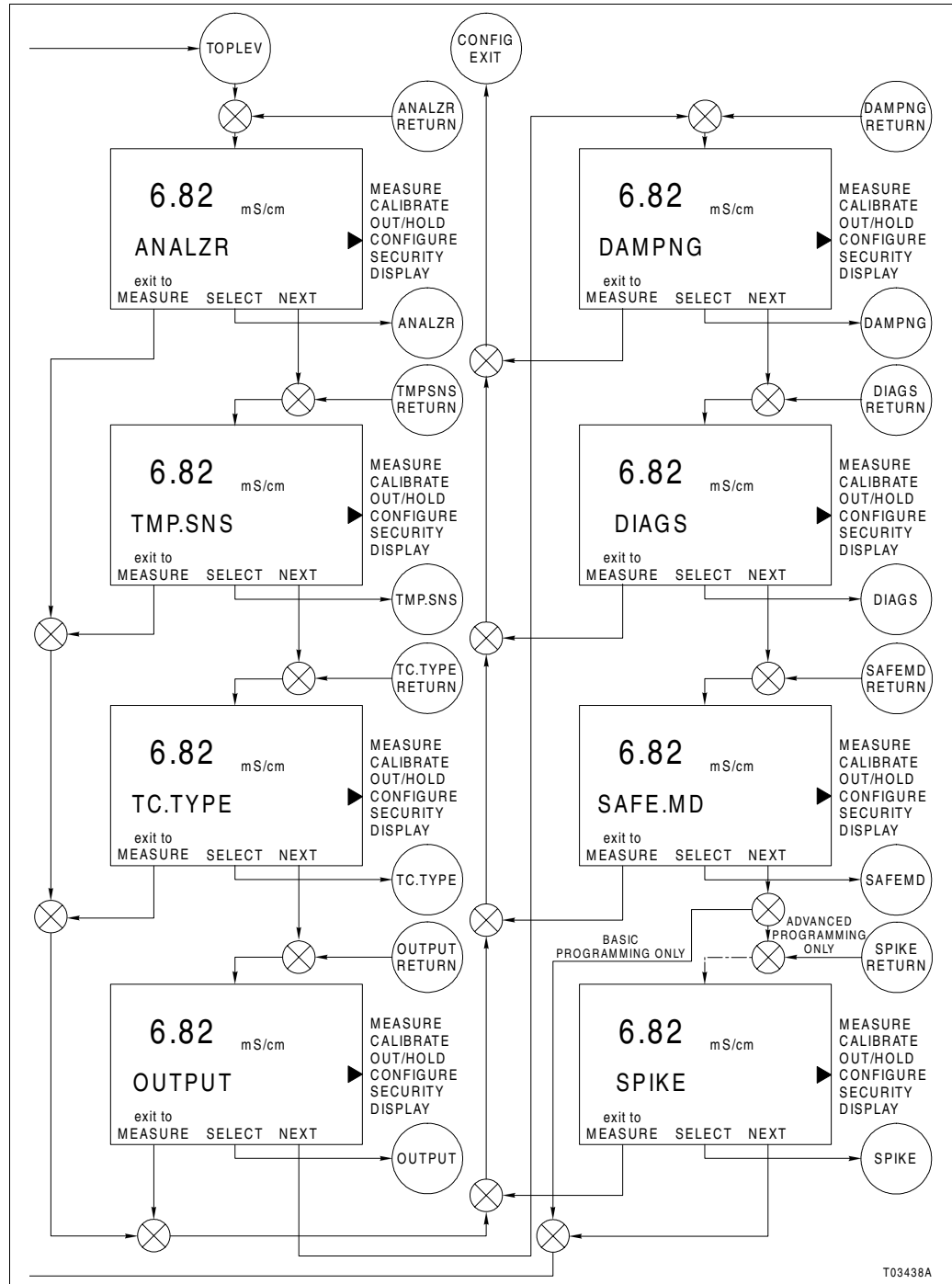

Figure 8-2. Modify Configure States Screen Flow

In some cases, more than one path can be taken during configuration. For paths that are in parallel, either complete all tasks in all paths before continuing or complete all tasks in only those paths that apply before continuing. At least one path must be completed.

Some blocks contain alphanumeric codes. These codes identify the procedure that describes the steps to complete an indicated task. Complete all steps given in a procedure before continuing to the next procedure.

The procedures have check boxes in the margin by each procedural step. When performing a procedure, check each box as each step is completed.

By treating each task as a separate entity, the procedures provide an easy method for finding the information needed to perform each task in the configuration sequence.

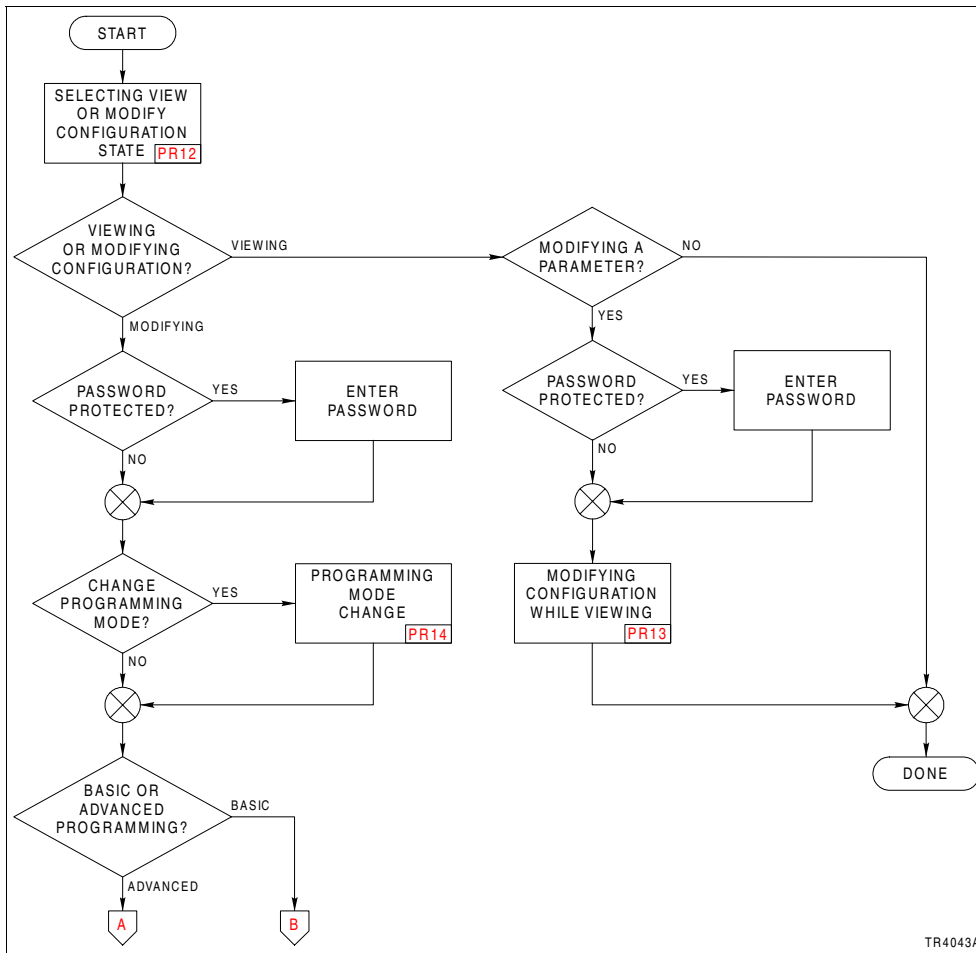

Figure 8-3. Configuration Sequence

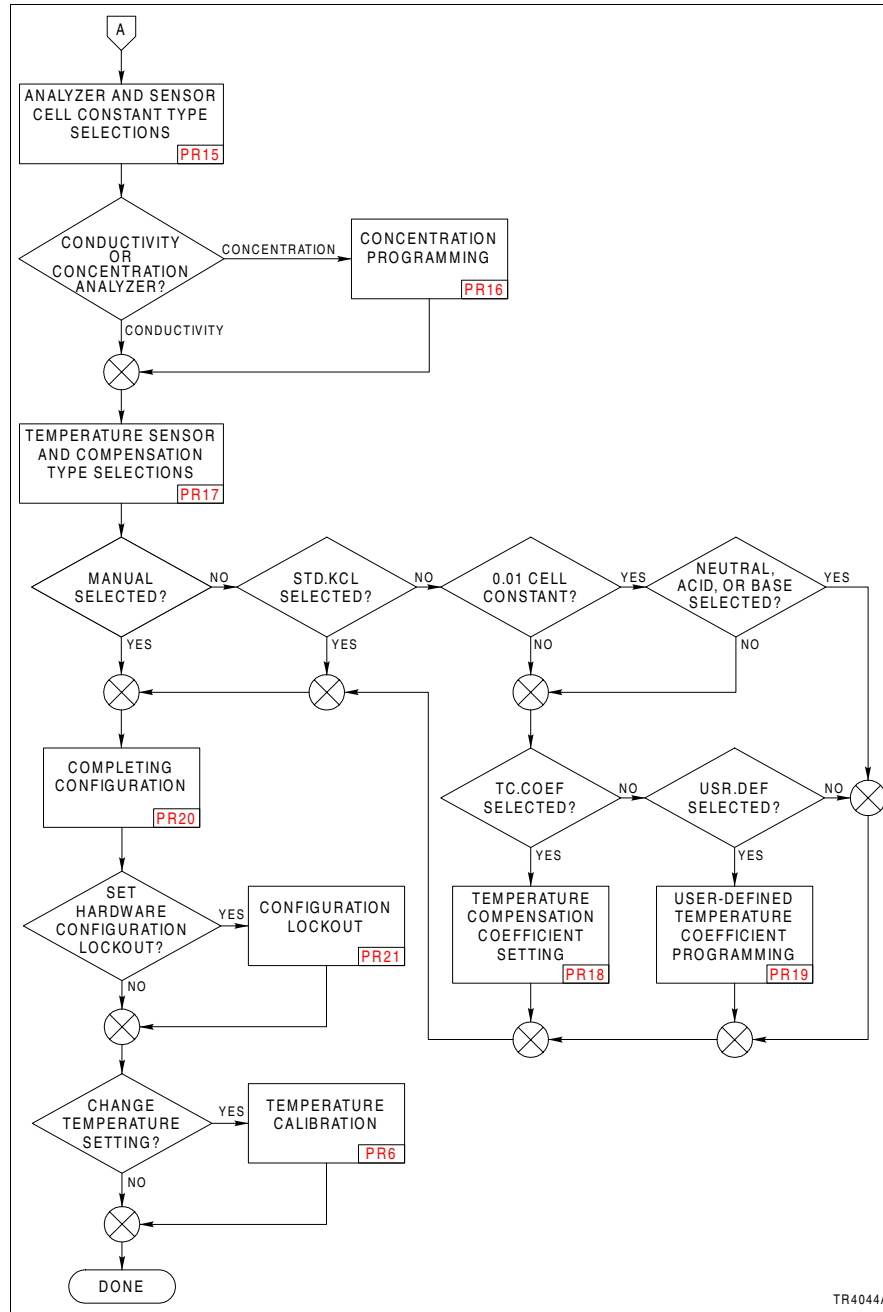

Figure 8-4. Advanced Configuration Sequence

TR4044A

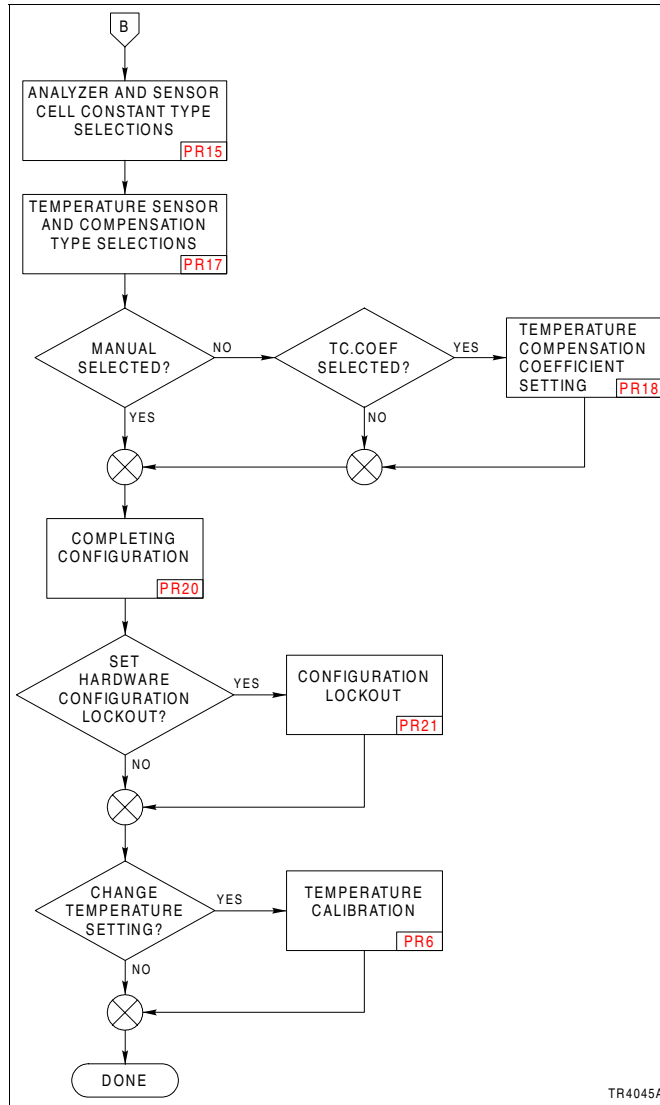

Figure 8-5. Basic Configuration Sequence

SECTION 9 - SECURITY MODE

INTRODUCTION

The security mode of operation establishes password protection against unauthorized changes to transmitter functions by unqualified personnel. Password protection can be assigned to the calibrate and output/hold modes of operation, and the modify configure state of operation.



SECURITY STATE

The security mode of operation contains one state of operation. This state provides password protection of critical operating environments. Each password protected mode or state of operation can have its security state toggled on or off in the associated security screen. All security assignments must be made before assigning a password.

The security of the security state itself is automatically set to on when one or more mode or state has the security on. One password assignment applies to all secured modes and states. Figure 9-1 shows the screen flow for the security state of operation.

ENTERING PASSWORD

When the security state has been set, the password must be entered to gain access to the modes and states that have been password protected.

1. When the password inquiry screen (*PASSWD*) appears:
 - a. The display reads `_ _ _`. Use the  smart key to increment the value of the blinking digit.
 - b. When the first digit value is correct, use the  smart key to move to the next digit.
 - c. Repeat Steps 1a and 1b for each digit.
2. Press the *ENTER* smart key to accept the password.

SECURITY SEQUENCE

There is only one procedure associated with the security mode. Refer to **PR22** to set the security states and password.

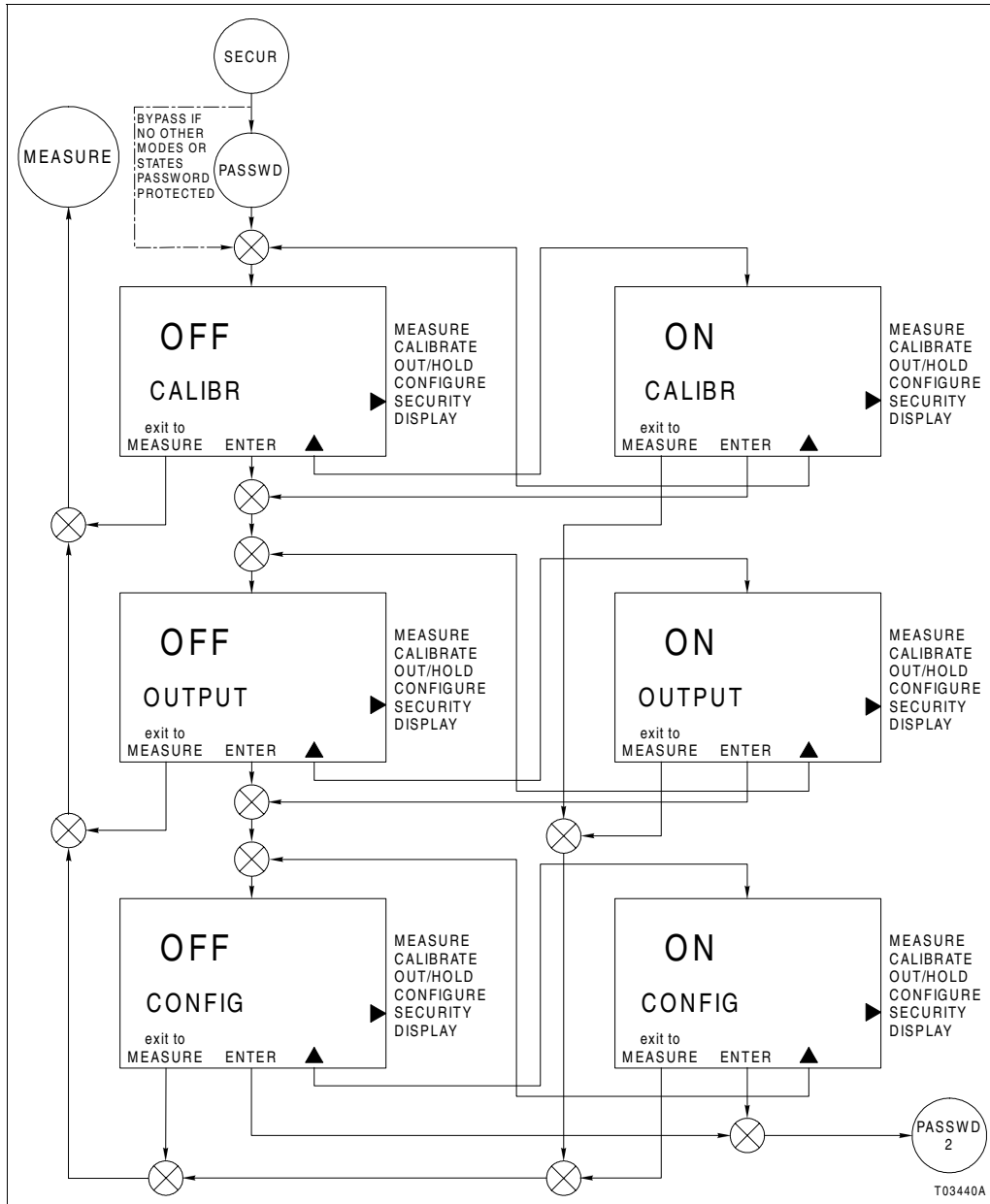

Figure 9-1. Security State Screen Flow

SECTION 10 - SECONDARY DISPLAY MODE

INTRODUCTION

The transmitter has two display regions active while in the measure mode of operation. The primary display region shows the measured variable. The secondary display region can show a multitude of process, sensor, or transmitter information: process temperature, current output value, sensor type, sensor cell constant, compensated conductivity (useful for concentration configurations), user-defined text description (concentration configuration only), spike mode status, and software revision. All of these are viewable in the secondary display region using the secondary display mode. Any of these can be set as the displayed value while in the measure mode of operation.

SECONDARY DISPLAY STATES OF OPERATION

The secondary display mode contains eight states. These provide information on the process temperature, transmitter settings, and transmitter status. As shown in Figure 10-1, each secondary state can be sequentially viewed by pressing the *NEXT* smart key. Any given secondary display state can be continually shown in the measure mode by pressing the *ENTER* smart key when the desired state is shown. The transmitter proceeds to the measure mode and displays the entered secondary display state in the secondary display region.

SECONDARY DISPLAY OPERATION

To use the secondary display mode and states of operation:

1. Press the *MENU* smart key until *DISPLAY* is highlighted on the display.
2. Press the *SELECT* smart key to enter the secondary display mode.
3. Press the *NEXT* smart key to sequentially view each secondary display state.
4. Press the *ENTER* smart key to have the desired secondary display state appear during the measure mode.

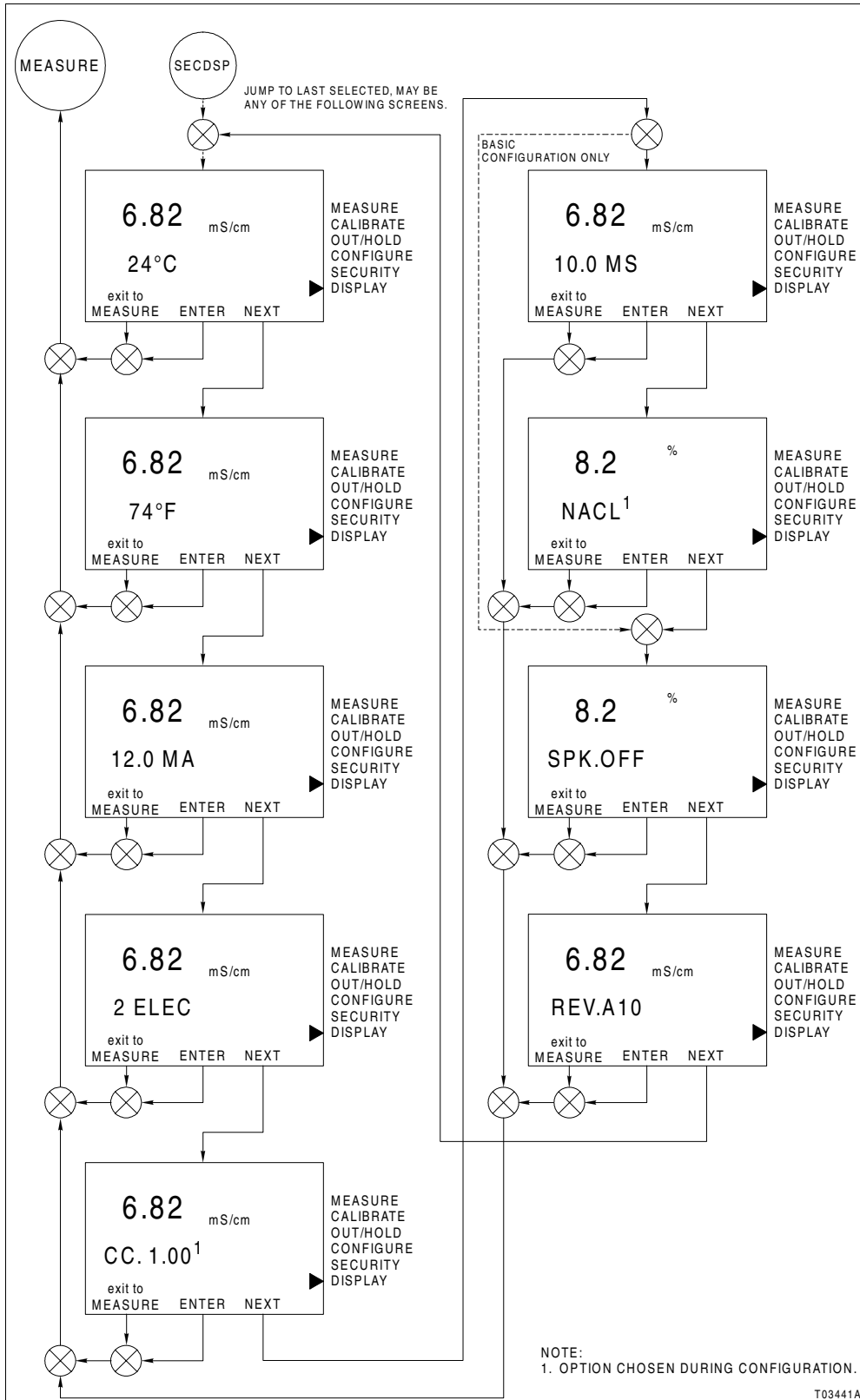

Figure 10-1. Secondary Display Mode Screen Flow

SECTION 11 - UTILITY MODE

INTRODUCTION

The transmitter has a utility mode of operation that provides access to powerful functions not usually needed during normal operating conditions. These functions have been separated into two categories: factory and user. Factory functions are reserved to ABB Instrumentation personnel. User functions include: programming mode selection, reset configuration to default values, remove security, reset all parameters to default values, and a software boot.

There is only one procedure for the utility mode (PR23). It contains brief descriptions of each utility mode state.

FACTORY AND USER STATES

Access the factory and user states of operation by using the hidden fifth key located in the center top of the front panel. Once pressed, the hidden key causes the textual prompt *USER* to display in the secondary display region. Pressing the *SELECT* smart key moves the transmitter into the user state. Pressing the *NEXT* smart key moves the transmitter to the factory selection. Pressing the *exit to MEASURE* smart key escapes back to the measure mode.

The user state consists of five states of operation. Table 11-1 describes the function of each state.

Table 11-1. User States

State	Display	Function
Mode	<i>MODE</i>	Sets programming mode (basic or advanced) that can be selected in the modify configure mode of operation.
Reset configuration	<i>RST.CON</i>	Resets configuration to factory defaults.
Reset security	<i>RST.SEC</i>	Resets security to <i>OFF</i> state for all applicable modes and modify configure state.
Reset all	<i>RST.ALL</i>	Resets all programming parameters such as configuration, calibration, output/hold, security, and secondary display functions to factory defaults.
Soft boot	<i>RST.SFT</i>	Initiates software reset.

The *NEXT* smart key sequentially moves through each of the five user states. This cycle repeats until a state is selected or the escape function is chosen using the *exit to MEASURE*

smart key. To select a state, press the *SELECT* smart key when the desired user state is shown in the secondary display region. Figure 11-1 identifies the smart key assignments and resulting action.

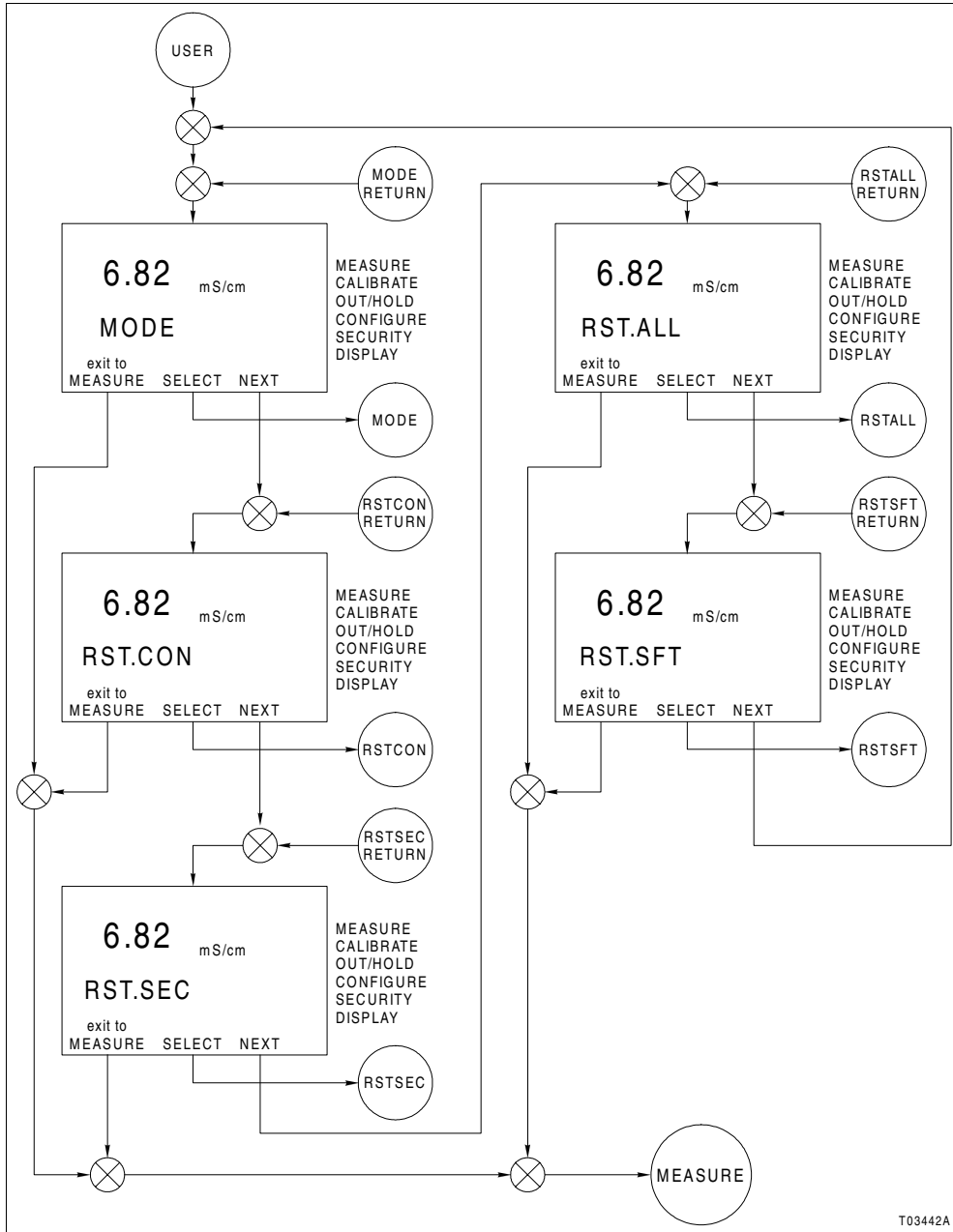

Figure 11-1. User State Screen Flow

SECTION 12 - DIAGNOSTICS AND TROUBLESHOOTING

INTRODUCTION

The Type TB82TE transmitter performs a number of diagnostic checks on hardware, software, and sensor functions. Upon detection of a nonconforming condition, the *FAULT* icon locally alerts the operator. Configurable remote indication is performed by using the spike output option to modulate the output current. Pressing the *FAULT info* smart key interrogates the transmitter as to the cause of the fault. The display of a short text string and fault code alternate on the secondary display. If multiple faults exist, pressing the *FAULT info* smart key moves the display to the next fault. Upon interrogation of all faults, the transmitter returns to the measure mode and the *MENU* smart key icon appears.

This section describes the type of fault conditions and their applicability to transmitter functionality. If the evaluation of the fault codes does not resolve the problem, refer to **TROUBLESHOOTING SEQUENCE** to find additional troubleshooting procedures.

FAULT CODES

Fault conditions are grouped into two categories based on their severity. Conditions that result in degradation of transmitter performance are reported as problem codes (PC). Conditions that render the transmitter inoperable are reported as error codes (EC).

Fault codes are reported in the secondary display region in a first in, first out (FIFO) order. All active fault conditions can be viewed at any time while in the measure mode by using the *FAULT info* smart key. A flashing *FAULT* icon indicates a new fault condition that has not been interrogated. Upon resolution of all fault conditions, the *FAULT* icon and *FAULT info* smart key disappear.

Problem Codes

Problem codes result from fault conditions that impact the performance of the transmitter. These conditions are usually resolved using standard practices.

The occurrence of a problem code fault condition energizes the *FAULT* icon and modulates the spike output (if configured). These diagnostic indicators provide local and remote reporting capability.

Table 12-1 lists common problem codes and Table 12-2 lists uncommon problem codes. Each entry lists the problem code number, displayed text string, a short description of the fault condition, and corrective action. Most problem codes have more than one corrective action listed. Perform the corrective actions in the order they appear until the problem is resolved.

Table 12-1. Common Problem Codes

Code	Text String	Description	Corrective Action
PC1	POLAR	Sensor polarization	Verify process conditions, specifically conductivity, are within values listed in Table 1-3.
			Verify sensor does not have any trapped air bubbles within the sensing cavity (near the center sensing electrode). Trapped air reduces sensor surface area and will affect accuracy of displayed conductivity and output current.
			Check cleanliness of sensor. If not clean, remove any foreign material. Clean sensor (PR27) and verify response to conductivity standards.
			Electronically test sensor (PR25). Replace if it does not meet requirements.
			Verify sensor wiring connections.
PC6	HI.LOOP	Current loop above upper range value (+0.4 mA hysteresis)	Verify process conditions are within configured output range. If PV is outside configured range, increase output range.
			Verify transmitter is configured for correct temperature compensation type.
			Conduct temperature calibration. If not using temperature sensor, verify configuration for <i>TMP.SNS</i> is <i>NONE</i> and proper process temperature is set.
			Verify sensor wiring connections.
			Remove any liquids, oils, scales, or corrosion from transmitter terminal block or extension cable junction box terminals.
			Clean sensor and perform process calibration.
			Electronically test sensor and temperature compensator (PR25). Replace sensor if it does not meet requirements.
PC7	LO.LOOP	Current loop below lower range value (-0.2 mA hysteresis)	Perform PC6 corrective actions.
PC8	HI.PV	PV above transmitter range	Verify process conditions are within transmitter range. PV must be within transmitter range.
			Verify sensor wiring connections.
			Verify sensor does not have any exposed wire from nicks, etc. If it does, repair (if possible) or replace.
			Remove any liquids, oils, scale, or corrosion from transmitter terminal block or extension cable junction box terminals.
			Verify sensor responds to conductivity standards. Replace sensor and/or sensor extension cable (if present) if sensor does not respond.
Electronically test sensor (PR25). Replace if it does not meet requirements.			

Table 12-1. Common Problem Codes (continued)

Code	Text String	Description	Corrective Action
PC9	LO.PV	PV below transmitter range	Perform PC8 corrective actions.
PC10	HI.TEMP	Temperature above transmitter range	Verify process conditions are within transmitter range. Temperature must be within transmitter range.
			Verify process conditions are within configured output range. If temperature is outside configured range, increase range.
			Verify sensor wiring connections.
			Remove any liquids, oils, scales, or corrosion from transmitter terminal block or extension cable junction box terminals.
			Conduct temperature calibration. If not using temperature sensor, verify configuration for <i>TMP.SNS</i> is <i>NONE</i> and proper process temperature is set.
			Electronically test sensor and temperature compensator (PR25). Replace sensor if it does not meet requirements.
PC11	LO.TEMP	Temperature below transmitter range	Perform PC10 corrective actions.
PC12	HI.T.AD	Open or missing temperature sensor	Verify process conditions are within transmitter range. Temperature must be within transmitter range.
			Verify process conditions are within configured output range. If temperature is outside configured range, increase range.
			Verify sensor wiring connections.
			Remove any liquids, oils, scales, or corrosion from transmitter terminal block or extension cable junction box terminals.
			Conduct temperature calibration. If not using temperature sensor, verify configuration for <i>TMP.SNS</i> is <i>NONE</i> and proper process temperature is set.
			Electronically test sensor and temperature compensator (PR25). Replace sensor if it does not meet requirements.
PC13	LO.T.AD	Shorted temperature sensor	Replace 2-electrode conductivity input PCB assembly.
			Perform PC12 corrective actions.

Table 12-2. Uncommon Problem Codes

Code	Text String	Description	Corrective Action
PC20	BAD.SEE	Bad SEEPROM or 2-electrode conductivity input PCB assembly	Input PCB factory calibration constants can not be loaded. Calibrate sensor and order replacement 2-electrode conductivity input PCB assembly. Existing assembly should properly function until new assembly is received.
PC21	NO.F.CAL	Missing factory calibration and functional SEEPROM	Contact ABB Instrumentation for factory calibration procedure. Calibrate sensor for short-term usage until factory calibration is performed or a new 2-electrode conductivity input PCB assembly is installed.
PC22	BLNK.uP	Blank microprocessor EEPROM	Cycle transmitter power.
			Contact ABB Instrumentation.

Table 12-2. Uncommon Problem Codes (continued)

Code	Text String	Description	Corrective Action
PC25	ROM.SUM	Incorrect EPROM checksum	Perform PC22 corrective actions.
PC30	R0.F.CAL	Out of range or missing factory calibration for conductivity circuit range zero	Contact ABB Instrumentation for factory calibration procedure. Calibrate sensor for short-term usage until factory calibration is performed.
PC31	R1.F.CAL	Out of range or missing factory calibration for conductivity circuit range one	
PC32	R2.F.CAL	Out of range or missing factory calibration for conductivity circuit range two	
PC33	R3.F.CAL	Out of range or missing factory calibration for conductivity circuit range three	
PC34	R4.F.CAL	Out of range or missing factory calibration for conductivity circuit range four	
PC35	G0.F.CAL	Out of range or missing factory calibration for ground loop circuit range zero	Contact ABB Instrumentation for factory calibration procedure. Calibrate sensor for short-term usage until factory calibration is performed.
PC36	G1.F.CAL	Out of range or missing factory calibration for ground loop circuit range one	
PC37	G2.F.CAL	Out of range or missing factory calibration for ground loop circuit range two	
PC38	G3.F.CAL	Out of range or missing factory calibration for ground loop circuit range three	
PC39	G4.F.CAL	Out of range or missing factory calibration for ground loop circuit range four	
PC45	BA.F.CAL	Out of range or missing factory calibration for 3-kΩ Balco temperature compensator	Contact ABB Instrumentation for factory calibration procedure. Calibrate temperature sensor for short-term usage until factory calibration is performed.
PC46	PT.F.CAL	Out of range or missing factory calibration for Pt 100 temperature compensator	
PC47	RT.F.CAL	Out of range or missing factory calibration for Pt 1000 temperature compensator	
PC50	R0.CHKS	Incorrect or missing conductivity circuit range zero checksum	Contact ABB Instrumentation for factory calibration procedure. Calibrate sensor for short-term usage until factory calibration is performed.
PC51	R1.CHKS	Incorrect or missing conductivity circuit range one checksum	
PC52	R2.CHKS	Incorrect or missing conductivity circuit range two checksum	
PC53	R3.CHKS	Incorrect or missing conductivity circuit range three checksum	
PC54	R4.CHKS	Incorrect or missing conductivity circuit range four checksum	
PC55	G0.CHKS	Incorrect or missing ground loop circuit range zero checksum	Contact ABB Instrumentation for factory calibration procedure. Calibrate sensor for short-term usage until factory calibration is performed.
PC56	G1.CHKS	Incorrect or missing ground loop circuit range one checksum	
PC57	G2.CHKS	Incorrect or missing ground loop circuit range two checksum	

Table 12-2. Uncommon Problem Codes (continued)

Code	Text String	Description	Corrective Action
PC58	G3.CHKS	Incorrect or missing ground loop circuit range three checksum	Contact ABB Instrumentation for factory calibration procedure. Calibrate sensor for short-term usage until factory calibration is performed.
PC59	G4.CHKS	Incorrect or missing ground loop circuit range four checksum	
PC65	BA.CHKS	Incorrect or missing 3-kΩ Balco temperature compensator checksum	Contact ABB Instrumentation for factory calibration procedure. Calibrate temperature sensor for short-term usage until factory calibration is performed.
PC66	PT.CHKS	Incorrect or missing Pt 100 temperature compensator checksum	
PC67	RT.CHKS	Incorrect or missing Pt 1000 temperature compensator checksum	
PC70	HI.G.L.AD	Ground loop signal above transmitter A/D range	2-electrode conductivity input PCB assembly ground loop circuit failure exists. Order replacement 2-electrode conductivity input PCB assembly. Calibrate sensor for short-term usage until factory calibration is performed. Existing 2-electrode conductivity input PCB assembly should function properly until new 2-electrode conductivity input PCB assembly is installed.
PC71	LO.G.L.AD	Ground loop signal below transmitter A/D range	
PC72	HI.D.S.AD	Dirty sensor above transmitter A/D range	2-electrode conductivity input PCB assembly dirty sensor diagnostic circuit failure exists. Order replacement 2-electrode conductivity input PCB assembly. Calibrate sensor for short-term usage until factory calibration is performed. Existing 2-electrode conductivity input PCB assembly should function properly until new 2-electrode conductivity input PCB assembly is installed.
PC73	LO.D.S.AD	Dirty sensor below transmitter A/D range	

Error Codes

Error codes result from fault conditions that render the transmitter inoperable. These conditions can not usually be resolved using standard practices.

The occurrence of an error code fault condition energizes the *FAULT* icon and enables the safe mode output. When in the safe mode, the current output is fixed high or low based on the configuration of the safe mode. These diagnostic indicators provide local and remote reporting capability.

Table 12-3 contains all the error codes supported by the transmitter. Each entry lists the error code number, displayed text string, and a short description of the fault condition.

WARNING

All error conditions are considered catastrophic and require transmitter replacement. Replace the transmitter with a transmitter that is known to be operable. Leaving an inoperable transmitter in the process could cause process upsets. Some process upsets can lead to dangerous conditions that can harm personnel and damage equipment.

When an error code appears on the transmitter display, the transmitter must be replaced with one that is known to be operable. Return the nonfunctional transmitter to ABB Instrumentation for repair. Contact ABB Instrumentation for processing instructions.

Table 12-3. Error Codes

Error Code	Text String	Description
EC1	HI.PV.AD	Overrange PV A/D
EC2	LO.PV.AD	Underrange PV A/D
EC3	PH.PCB	pH/ORP/pION input PCB with conductivity firmware
EC4	TC.PCB	Toroidal conductivity input PCB with 4-electrode conductivity firmware
EC6	TE.PCB	2-electrode conductivity input PCB with 4-electrode conductivity firmware
EC7	EC.PCB	Electrode conductivity input PCB with 4-electrode conductivity firmware

CALIBRATION DIAGNOSTICS

The transmitter performs automatic efficiency and offset calculations. These calculations are relative to a theoretically perfect conductivity and temperature sensor and are conducted after each calibration cycle. Calibration history is retained for future interrogation using the edit calibrate state. The calibration constants displayed are slope and offset for the PV and temperature.

A slope of less than 0.2 or greater than five for the PV indicates a potentially bad process calibration point or poorly performing sensor. In these cases, the text string *BAD.CAL* appears on the secondary display. The transmitter returns to the beginning of the calibration cycle after it reports the bad calibration.

An offset value of less than -20 or greater than +20 microsiemens per centimeter for a nominal sensor cell constant value of 1.00, less than -4 or greater than +4 microsiemens per centimeter for a nominal sensor cell constant value of 0.10, and less than -0.8 or greater than +0.8 microsiemens per centimeter for a nominal sensor cell constant value of 0.01 also indicates a potentially bad process calibration or poorly

performing sensor. In these cases, the transmitter reports the bad calibration and returns to the beginning of the calibration cycle.

The transmitter reports a bad temperature calibration and rejects calibration values for slope values less than 0.2 or greater than 1.5 and offset values less than -40-degrees Celsius or greater than +40-degrees Celsius. Temperature calibrations use smart software routines that automatically adjust the value for slope, offset, or both based on the calibration value being entered and the calibration history if it exists.

ADDITIONAL DIAGNOSTICS

Other diagnostic messages may appear during transmitter programming. These messages include *BAD.VAL* (bad value), *DENIED*, and *RAM.ERR* (RAM error).

BAD.VAL indicates the attempted numeric entry of a value out of the allowed range of the transmitter. Table 1-3 lists the transmitter range limits.

DENIED indicates incorrect entry of a security password. Section 9 contains information on security.

RAM.ERR indicates a RAM read/write error. The transmitter automatically resets when this error has been encountered. If the transmitter continues to reset, contact ABB Instrumentation for problem resolution.

TROUBLESHOOTING SEQUENCE

Refer to Figure 12-1 for the transmitter troubleshooting sequence. Each block of the flow represents a single task that must be completed before continuing with the sequence.

In some cases, more than one path can be taken during troubleshooting. For paths that are in parallel, either complete all of the tasks in all of the paths before continuing or complete all of the tasks in only those paths that apply before continuing. At least one path must be completed.

Some blocks contain alphanumeric codes. These codes identify the procedure that describes the steps to complete an indicated task. Complete all of the steps given in a procedure before continuing to the next procedure.

The procedures have check boxes in the margin by each procedural step. When performing a procedure, check each box as each step is completed.

By treating each task as a separate entity, the procedures provide an easy method for finding the information needed to perform each task in the troubleshooting sequence.

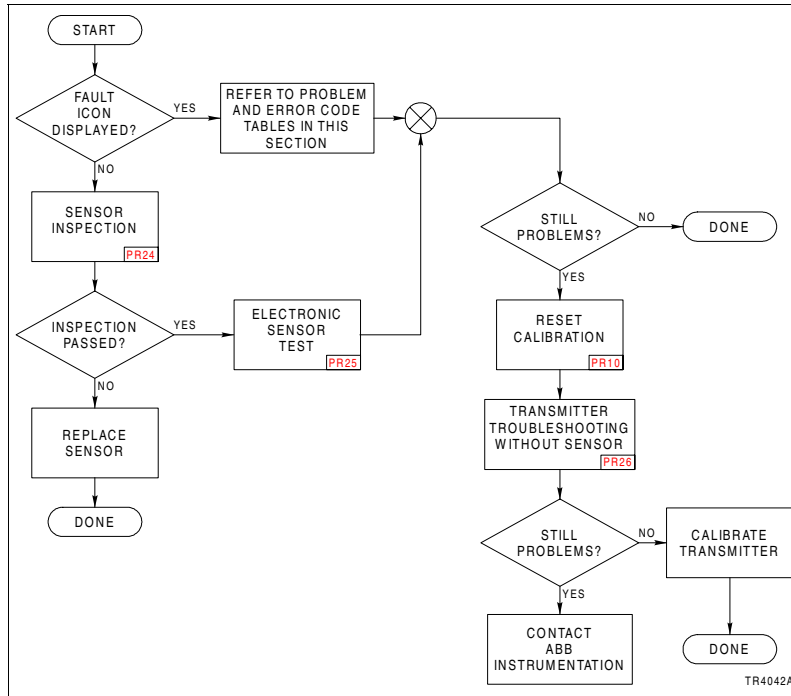

Figure 12-1. Troubleshooting Sequence

SECTION 13 - MAINTENANCE

INTRODUCTION

This section contains a preventive maintenance schedule for the Type TB82TE transmitter (Table 13-1). This table has a procedure reference next to the task when applicable. The reference indicates the procedure number where the procedure for that task can be found.

WARNING

Allow only qualified personnel (refer to *INTENDED USER* in Section 1) to commission, operate, service, or repair this equipment. Failure to follow the procedures described in this instruction or the instructions provided with related equipment can result in an unsafe condition that can injure personnel and damage equipment.

Be sure to follow all warnings, cautions, and notes. Put boards containing semiconductors into antistatic bags when stored or shipped back to the factory. Do not repair printed circuit boards in the field. All repairs and adjustments should be performed by qualified personnel.

The maintenance of any stand-alone product or control system affects the reliability of that product. ABB Instrumentation recommends that all equipment users practice a preventive maintenance program that will keep the equipment operating at an optimum level.

The procedures referred to in this section contain instructions that the customer should be able to perform on site. These preventive maintenance procedures should be used as a guideline to assist in establishing good preventive maintenance practices. Select the minimum steps required to meet the cleaning needs of your system.

Personnel performing preventive maintenance should meet the following qualifications:

- Maintenance personnel should be qualified electrical technicians or engineers that know the proper use of test equipment.
- Maintenance personnel should be familiar with the transmitter and have experience working with process control systems.

PREVENTIVE MAINTENANCE SCHEDULE

Table 13-1 is the preventive maintenance schedule for the Type TB82TE transmitter. The table lists the preventive maintenance tasks in groups according to their specified maintenance interval. Some tasks in Table 13-1 are self explanatory. Instructions for tasks that require further explanation are found in the procedures or in the documentation supplied with any associated equipment.

Table 13-1. Preventive Maintenance Schedule

Task	Procedure	Frequency (months)
Check and clean all wiring and wiring connections.	—	12
Calibrate transmitter output.	PR8	
Inspect sensor.	PR24	As required
Clean sensor.	PR27	
Clean keypad.	PR28	
Calibrate transmitter sensor input.	Fig. 6-2	
Clean and lubricate all gaskets and O-rings, or replace and lubricate if damage is evident.	—	Each time seals are broken
Complete all tasks in this table.	—	Shutdown

SECTION 14 - REPAIR AND REPLACEMENT

INTRODUCTION

Due to the modular design of the Type TB82TE transmitter, the replacement of an assembly can be easily completed. Replacements are available for each major assembly. These include the two-electrode conductivity input PCB, microprocessor PCB, power supply PCB, front bezel, shell, and rear cover assemblies.

This section does not contain repair instructions for the sensor. Refer to [Section 12](#) for diagnostics and troubleshooting information. Due to the nature of its design, if the troubleshooting procedures do not solve the problem, complete sensor replacement is required when it has been damaged or does not properly function.

WARNING

Do not substitute any components other than those listed in the appropriate procedures. Doing so will compromise the certification listed on the transmitter nameplate. Invalidating these certifications can lead to unsafe conditions that can injure personnel and damage equipment.

Do not disconnect equipment unless power has been switched off at the source or the area is known to be nonhazardous. Disconnecting equipment in a hazardous location with source power on can produce an ignition-capable arc that can injure personnel and damage equipment.

REPAIR AND REPLACEMENT SEQUENCE

Refer to Figure [14-1](#) for the repair sequence for the transmitter. Each block of the flow represents a single task that must be completed before continuing with the sequence.

In some cases, more than one path can be taken during repair. For paths that are in parallel, either complete all of the tasks in all of the paths before continuing or complete all of the tasks in only those paths that apply before continuing. At least one path must be completed.

Some blocks contain alphanumeric codes. These codes identify the procedure that describes the steps to complete an indicated task. Complete all of the steps given in a procedure before continuing to the next procedure.

The procedures have check boxes in the margin by each procedural step. When performing a procedure, check each box as each step is completed.

By treating each task as a separate entity, the procedures provide an easy method for finding the information needed to perform each task in the repair sequence.

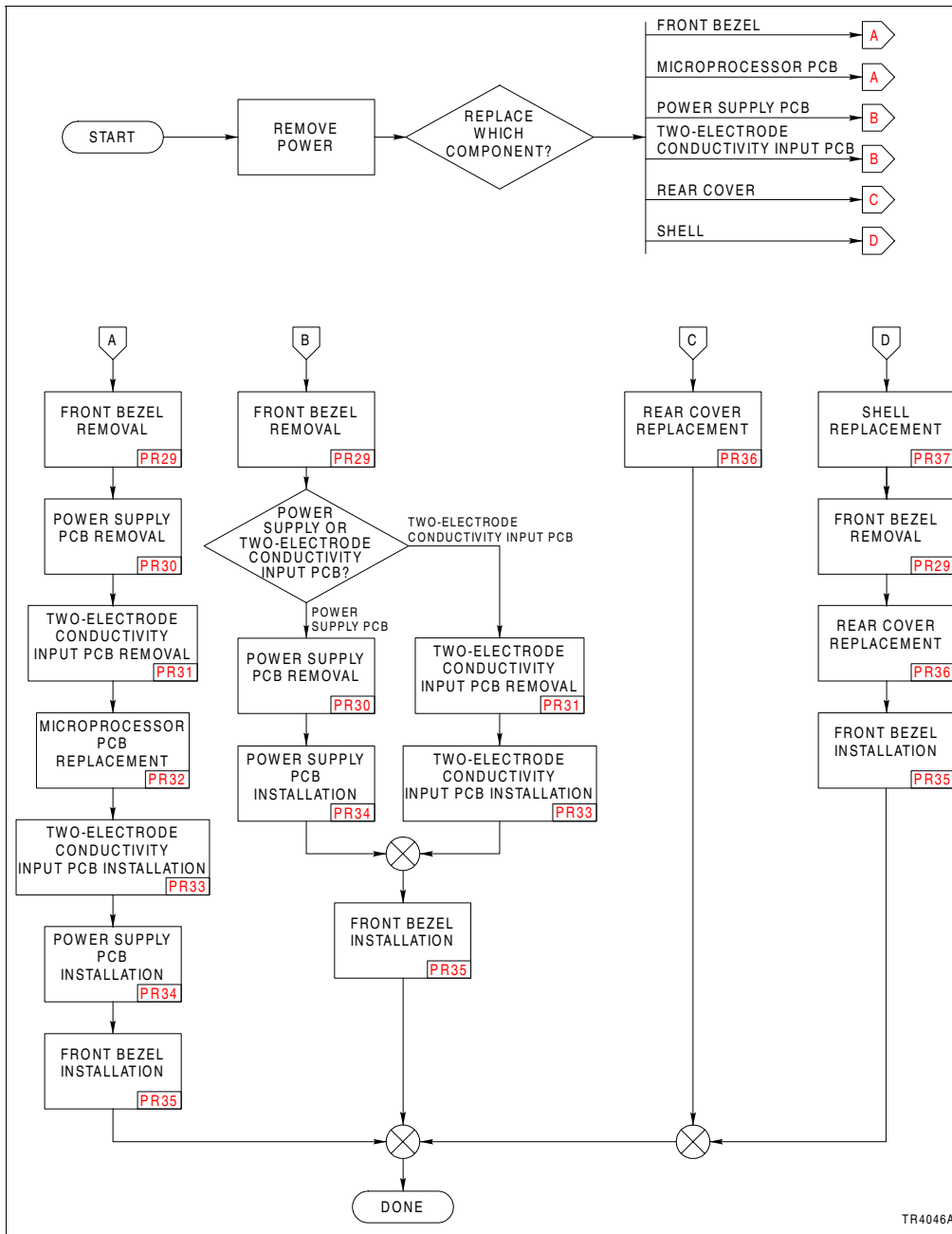

Figure 14-1. Repair and Replacement Sequence

SECTION 15 - SUPPORT SERVICES

INTRODUCTION

Figure 15-1 is an assembly drawing of the Type TB82TE transmitter. When ordering replacement parts, specify nomenclature type, part name, and part number of spare parts kits.

ABB Instrumentation is ready to assist in the use and repair of its products at any time. Requests for sales and/or application service should be made to the nearest sales or service office.

Factory support in the use and repair of the Type TB82TE transmitter can be obtained by contacting:

ABB Instrumentation
2175 Lockheed Way
Carson City, NV 89706
Phone: (775) 883-4366
FAX: (775) 883-4373
Web site: <http://www.tbi-bailey.com>
E-mail: support@tbi-bailey.com

RETURN MATERIALS PROCEDURES

If any equipment should need to be returned for repair or evaluation, please contact ABB Instrumentation at (775) 883-4366, or your local ABB Instrumentation representative for the return materials authorization (RMA) number. At the time the number is given, repair costs will be provided, and a customer purchase order will be requested. The RMA and purchase order numbers must be clearly marked on all paperwork and on the outside of the return package container.

Equipment returned to ABB Instrumentation with incorrect or incomplete information may result in significant delays or nonacceptance of the shipment.

REPLACEMENT PARTS

When making repairs at your facility, order spare parts kits from a ABB Instrumentation sales office. Provide this information.

1. Spare parts kit description, part number, and quantity.
2. Model and serial number (if applicable).
3. ABB Instrumentation instruction number, page number, and reference figure that identifies the spare parts kit.

When ordering standard parts from ABB Instrumentation, use the part numbers and descriptions from **RECOMMENDED SPARE PARTS KITS**. Order parts without commercial descriptions from the nearest ABB Instrumentation sales office.

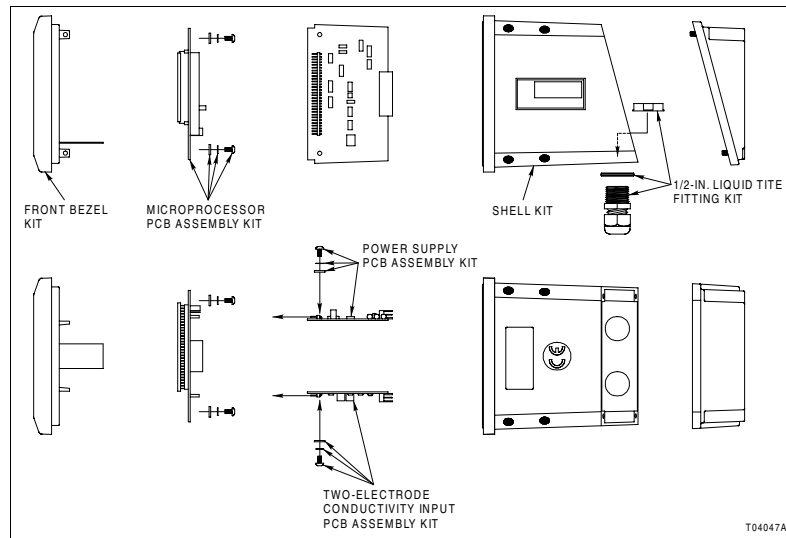

Figure 15-1. Exploded View

RECOMMENDED SPARE PARTS KITS

Table 15-1 lists the recommended spare parts kits.

Table 15-1. Spare Parts Kits

Part Number	Description
4TB9515-0155	Power supply PCB assembly kit
4TB9515-0157 ¹	Power supply PCB assembly kit for HART compatible transmitters
4TB9515-0158	Power supply PCB assembly with lightning arrestor kit
4TB9515-0159 ¹	Power supply PCB assembly with lightning arrestor kit for HART compatible transmitters
4TB9515-0160	Front bezel kit
4TB9515-0162	Rear cover kit
4TB9515-0163	½-in. liquid-tite cable grip fitting kit
4TB9515-0175	Shell kit
4TB9515-0177	ROM (read only memory) chip, TB82TE and TB82TE firmware
4TB9515-0178	Microprocessor PCB/display board (firmware included)
4TB9515-0181	Front bezel kit, FM approved
4TB9515-0187	Two-electrode conductivity input PCB assembly

NOTE:

1. Contact ABB Instrumentation for availability.

APPENDIX A - TEMPERATURE COMPENSATION

INTRODUCTION

The Type TB82TE transmitter has a variety of standard conductivity temperature compensation options. These include:

- Manual (0.1N KCl based).
- Standard automatic (0.1N KCl based).
- Temperature coefficient (0.00 to 9.99%/°C).
- User-defined.

Additionally, three specialized types of automatic temperature compensation are available for the measurement of pure water using a nominal sensor cell constant of 0.01. These types include neutral salt, trace base, and trace acid.

The concentration analyzer configuration offers the same temperature compensation options as does the standard conductivity analyzer configuration.

TEMPERATURE COMPENSATION TYPES

Both the conductivity and concentration analyzer types offer six types of temperature compensation. Manual temperature compensation is based on 0.1N KCl. The reference temperature is fixed to 25-degrees Celsius for basic programming and is adjustable to any value within the transmitter range for advanced programming.

Automatic temperature compensation can be set to one of several types. When configured for automatic temperature compensation, the transmitter measures the process temperature via the temperature compensator located either in the sensor or external to the sensor. It automatically adjusts the raw conductivity to a conductivity referenced to 25-degrees Celsius for basic programming and is adjustable to any value within the transmitter range for advanced programming.

Standard KCl

The standard KCl temperature compensation option characterizes the temperature effect of 0.1N KCl. The data break-points are listed in Table A-1. The value K_{REF} in Table A-1 is the conductivity at 25-degrees Celsius. The Value K_T in Table A-1 is the conductivity at temperature T in degrees Celsius.

Table A-1. Standard KCl Data Breakpoints

Temperature (°C)	K_{REF}/K_T
0	1.80
5	1.57
10	1.38
15	1.22
20	1.10
25	1.00
30	0.91
50	0.69
75	0.50
100	0.38
128	0.30
156	0.25
306	0.18

Temperature Coefficient

The temperature coefficient option allows for a fixed correction based on a percentage change of the reference conductivity (conductivity at 25-degrees Celsius) per degree Celsius. The temperature compensation factor is derived from the equation:

$$\alpha = TC.COEF = \frac{\left(\frac{K_T}{K_{REF}} - 1.0\right) \times 100.0}{T - 25.0}$$

where:

- α and TC.COEF Percentage change in reference conductivity per degree Celsius.
- K_T Conductivity at temperature T (°C).
- K_{REF} Conductivity at the reference temperature (e.g., 25°C).
- T Temperature of solution (°C)

Typical ranges for temperature compensation coefficients are:

- Acids: 1.0 to 1.6%/°C.
- Bases: 1.8 to 2.0%/°C.
- Salts: 2.2 to 3.0%/°C.
- Neutral water: 2.0%/°C.

User-Defined

The user-defined temperature compensation option allows entry of six ratio values for K_T/K_{REF} and temperature values. The value K_{REF} is the conductivity at the reference temperature (e.g., 25-degrees Celsius). The value K_T is the conductivity at temperature T in degrees Celsius. Choose each slope value to provide the closest fit of each linear segment to the actual temperature in degrees Celsius versus the K_T/K_{REF} relationship.

Pure Water

When using a sensor with a cell constant of 0.01, three pure water temperature compensation options are available. These include neutral salt (*NEUTRL*), trace acid (*ACID*), and trace base (*BASE*). The reference temperature for these types of temperature compensation is 25-degrees Celsius for basic programming and is adjustable to any value within the transmitter range for advanced programming.

Temperature compensation for all three types of pure water is a polynomial based on data from T.S. Light. This equation compensates for variations in conductivity due to pure water. Temperature compensation for the effect of pure water becomes insignificant compared to the effects brought about by the solute for water having a conductivity value of greater than 0.5 microsiemens per centimeter. Using pure water temperature compensation for water with a conductivity greater than 0.5 microsiemens per centimeter will not cause errors; however, the compensation on solute effects (neutral salt, trace acid, trace base) may not accurately adjust for effects caused by the process liquid.

The polynomial is:

$$Factor = K_0 + K_1 \times T + K_2 \times T^2 + K_3 \times T^3 + K_4 \times T^4 + K_5 \times T^5 + K_6 \times T^6$$

The pure water coefficient values (K_0 , K_1 , K_2 , etc.) are listed in Table A-2.

Table A-2. Pure Water Coefficient Values

Coefficient	Pure Water	Salt	Trace Acid	Trace Base
K_0	1.170848E-02	0.532688	0.7000	0.5700
K_1	9.101055E-04	1.439182E-02	0.0120	0.0172
K_2	2.132244E-07	2.852080E-04	—	—
K_3	4.548839E-07	-6.504617E-06	—	—
K_4	-4.042016E-11	9.640603E-08	—	—
K_5	0.0	-6.982205E-10	—	—
K_6	0.0	1.887667E-12	—	—

APPENDIX B - CONCENTRATION PROGRAMMING

INTRODUCTION

The concentration analyzer configuration has one user-defined option. This provides a six-point, five-segment linear approximation of a specific conductivity-to-concentration curve. When using the user-defined option, choose custom units by either selecting one of the three engineering unit icons or enter a six-character, alphanumeric string.

USER-DEFINED CONDUCTIVITY-TO-CONCENTRATION CURVES

The transmitter may be used in any range and with any ABB Instrumentation two-electrode conductivity sensor when using the concentration analyzer option. This allows infinite programming capability.

The user-defined option allows the characterization of conductivity-to-concentration curves. These curves are determined separately in a laboratory or from published data such as that in the **International Critical Tables**. These curves are then segmented into five straight lines and programmed into the transmitter using the format shown in Figure **PR16-1**.

During this procedure, some rules must be followed.

- Point 1 for both conductivity and concentration is always the zero-percent (four-milliampere) output point.
- Point 6 for both conductivity and concentration is always the 100-percent (20-milliampere) output point.
- All conductivity points must be ascending. Concentration points can be either ascending or descending.
- If a reverse acting output is desired, swap the output range values either in the modify configure state or the output rerange state.
- The output range (four and 20-milliampere output range) can not exceed the point one and point six concentration range; however, the output range is compressible using the rerange (*RERNGE*) function while in the output/hold mode.

The engineering units that appear on the primary display are user-defined. Select either *PPM*, *PPB*, or *%* to appear in the primary display, or enter a six-character, alphanumeric string. This string appears permanently or temporarily on the secondary display.

APPENDIX C - PROGRAMMING TEXT STRING GLOSSARY

INTRODUCTION

When programming the transmitter, the six-character, alphanumeric region displays a wide variety of text prompts. In many cases, these prompts are abbreviations or portions of words.

TEXT PROMPTS

Table C-1 lists the text prompts and their full text equivalents.

Table C-1. Text Prompt Equivalents

Text Prompt	Equivalent
20MA.PT	20-mA point
3K.BLCO	3-k Ω Balco (temperature compensation)
4MA.PT	4-mA point
AAAAAA	Alphanumeric entry
ACID	Acid
ADVNC	Advanced programming state
ANALZR	Analyzer state
AUTO	Automatic temperature compensation
BAD.CAL	Bad calibration - entered value caused calculated values to exceed maximum values
BAD.VAL	Bad value - entered value exceeded maximum or minimum allowable value for entered parameter
BASE	Base
BASIC	Basic programming state
CALIBR	Calibrate mode
CON.CAL	Conductivity or concentration calibration state
CONCEN	Concentration
COND	Conductivity
CONFIG	Configure mode
D.P. POS	Decimal point position
DAMPNG	Damping state
DENIED	Incorrect security password entered
DIAGS	Diagnostic state
DISABL	Disable
EDT.CAL	Edit calibration state
FAIL.HI	Fail high (20 mA)
FAIL.LO	Fail low (4 mA)
HLD.LVL	Hold level
HOLD	Hold state

Table C-1. Text Prompt Equivalents (continued)

Text Prompt	Equivalent
K1/K25	Conductivity at temperature Point 1 to reference conductivity at 25°C. Points 2 through 6 represented in same manner.
MANUAL	Manual temperature compensation
MODIFY	Modify configure state
NEUTRL	Neutral
NEW.VAL	New calibration value. The PV or temperature value expected during a PV or temperature calibration.
NEW.VL.C	New value in °C
NO D.P.	No decimal point
NO.ICON	No icon desired in primary display
NONE	None
OUT.CAL	Output calibration state
OUTPUT	Output mode
PASSWD	Security password
POLAR	Sensor polarization
PT 100	Pt 100 RTD
PT1000	Pt 1000 RTD
PUR.H2O	Pure water
PV OFF	Process variable offset
PV SLOPE	Process variable slope
REL.HLD	Release hold
RERANG	Rerange state
RESET?	Conduct a reset operation?
REV.A10	Software revision A10
RST.ALL	Reset all parameters to factory settings
RST.CAL	Reset calibration constant and data to factory settings
RST.CON	Reset configurations to factory settings
RST.SEC	Reset security — remove any existing security
SAFE.MD	Safe mode state
SAVE?	Save the configuration?
SEC.DSP	Secondary display mode
SECS	Seconds
SECUR	Security mode
SLF.TST	Self test
SLOPE	Slope
SPIKE	Spike output state
SPK.MAG	Spike output magnitude
SPK.OFF	Spike output function set to off (disabled)
SPK.ON	Spike output function set to on (enabled)
STABL?	Is the displayed process variable stable?
T.OFF°C	Temperature offset in °C

Table C-1. Text Prompt Equivalents (continued)

Text Prompt	Equivalent
TC.COEFF	Temperature compensation coefficient
TC.TYPE	Temperature compensation type state
TMP	Temperature
TMP.CAL	Temperature calibration state
TMP.SLP	Temperature slope
TMP.SNS	Temperature sensor type state
U.D.UNIT	User-defined engineering units
UNITS	Engineering units
USR.DEF	User-defined
VIEW	View configure state
X1.COND	Conductivity independent variable value (X point) for break point 1 in conductivity units. Points 2 through 6 represented in same manner.
Y1.COND	Concentration dependent variable value (Y point) for break point 1 in concentration units. Points 2 through 6 represented in same manner.

FLOW TREE

Figure C-1 is a function flow tree for the Type TB82TE transmitter.

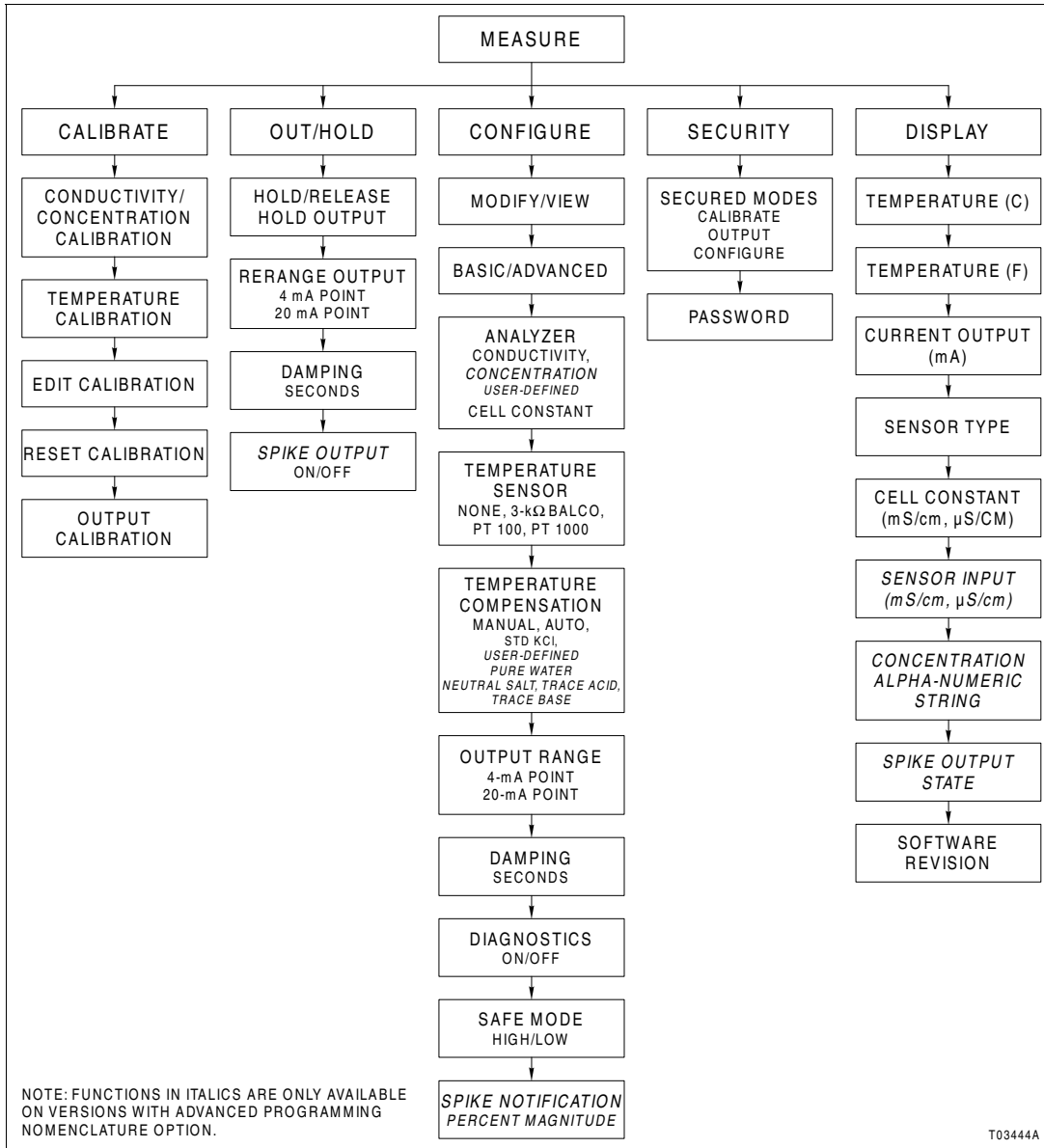

Figure C-1. Function Flow Tree

Type TB82TE Advantage Series Two-Wire, Two-Electrode Conductivity/Concentration Transmitter

TAG _____

DATE _____

PROGRAMMING MODE Basic

Advanced

ANALYZER TYPE _____

Conductivity

Concentration

Cell Constant 0.01 0.10 1.00

Cell Constant 0.01 0.10 1.00

User-defined
Engineering units _____

COND1 _____ CONC1 _____

COND2 _____ CONC2 _____

COND3 _____ CONC3 _____

COND4 _____ CONC4 _____

COND5 _____ CONC5 _____

COND6 _____ CONC6 _____

TEMPERATURE SENSOR None

3-k Ω Balco

Pt 100

Pt 1000

TEMPERATURE COMPEN-
SATION TYPE Manual

Auto

Standard (0.1N KCl)

Coefficient: Value _____

User-defined

T1 _____ K_{STD}/K₁ _____

T2 _____ K_{STD}/K₂ _____

T3 _____ K_{STD}/K₃ _____

T4 _____ K_{STD}/K₄ _____

T5 _____ K_{STD}/K₅ _____

T6 _____ K_{STD}/K₆ _____

Pure water

Neutral

Acid

Base

OUTPUT RANGE 4 mA _____

20 mA _____

DAMPING VALUE _____sec

DIAGNOSTICS Enabled

Disabled

SAFE MODE LEVEL Fail Low

Fail High

SPIKE MAGNITUDE _____%

SECURITY Password _____

Configure

Calibrate

Output/Hold

PROCEDURE INDEX

INTRODUCTION

This index is provided as a quick reference for those with a thorough knowledge of the Type TB82TE transmitter, related sensors, and this instruction. Procedures referenced in this index are part of an overall sequence. Going directly to a procedure without consulting the sequence flowcharts presented earlier in this instruction will not give an indication of what comes before and after in the sequence.

Title	Procedure
Analyzer and sensor cell constant type selections	PR15
Completing configuration	PR20
Concentration programming	PR16
Configuration lockout	PR21
Edit calibration	PR9
Electronic sensor test	PR25
Front bezel installation	PR35
Front bezel removal	PR29
Hinge mounting	PR4
Keypad cleaning	PR28
Microprocessor PCB replacement	PR32
Modifying configuration while viewing	PR13
Output calibration	PR8
Output/hold mode	PR11
Panel mounting	PR2
Pipe mounting	PR1
Power supply PCB installation	PR34
Power supply PCB removal	PR30
Programming mode change	PR14
PV calibration	PR7
Rear cover replacement	PR36
Reset calibration	PR10
Security and password assignment	PR22
Selecting view or modify configuration state	PR12
Sensor cleaning	PR27
Sensor inspection	PR24
Shell replacement	PR37
Temperature calibration	PR6
Temperature compensation coefficient setting	PR18
Temperature sensor and compensation type selections	PR17

Title	Procedure
Transmitter troubleshooting without sensor	PR26
Two-electrode conductivity input PCB installation	PR33
Two-electrode conductivity input PCB removal	PR31
User-defined temperature coefficient programming	PR19
Utility mode	PR23
Wall mounting	PR3
Wiring and grounding	PR5

PROCEDURE PR1 - PIPE MOUNTING

PURPOSE/SCOPE

30 min.

This procedure describes how to mount the transmitter to a pipe using pipe mounting kit 4TB9515-0124.

Parts

Number	Qty	Description
4TB4704-0086	4	Bolt, $\frac{3}{8}$ -in. x $\frac{3}{4}$ -in.
4TB4704-0096	2	U-bolt, $\frac{5}{16}$ -in.
4TB4704-0119	4	Bolt, $\frac{3}{8}$ -in. x $\frac{5}{8}$ -in.
4TB4710-0022	8	Lockwasher, $\frac{3}{8}$ -in.
4TB4710-0023	4	Lockwasher, $\frac{5}{16}$ -in.
4TB4710-0025	4	Flatwasher, $\frac{5}{16}$ -in.
4TB4710-0028	8	Flatwasher, $\frac{3}{8}$ -in.
4TB4711-0013	4	Nut, $\frac{5}{16}$ -in.
4TB4711-0020	4	Nut, $\frac{3}{8}$ -in.
4TB5008-0022	1	Bracket, pipe mounting
4TB5008-0071	1	Bracket, instrument mounting
Customer-supplied	A/R	Fitting, liquid tight

Tools

- Crescent wrench.

PROCEDURE

The pipe mounting kit contains a pipe mounting bracket, an instrument mounting bracket, and associated hardware. The pipe mounting bracket accommodates pipe diameters as large as two inches.

1. Select the location and orientation of the transmitter.
2. Refer to Figure **PR1-1** and use four $\frac{3}{8}$ -inch by $\frac{3}{4}$ -inch bolts, $\frac{3}{8}$ -inch flatwashers, $\frac{3}{8}$ -inch lockwashers, and $\frac{3}{8}$ -inch nuts to attach the instrument mounting bracket to the pipe mounting bracket.
3. Tighten the hardware using the crescent wrench.
4. Use the two U-bolts, and four each of the $\frac{5}{16}$ -inch flat washers, $\frac{5}{16}$ -inch lockwashers, and $\frac{5}{16}$ -inch nuts to attach the pipe mounting bracket to the pipe.
5. Tighten the hardware using the crescent wrench.

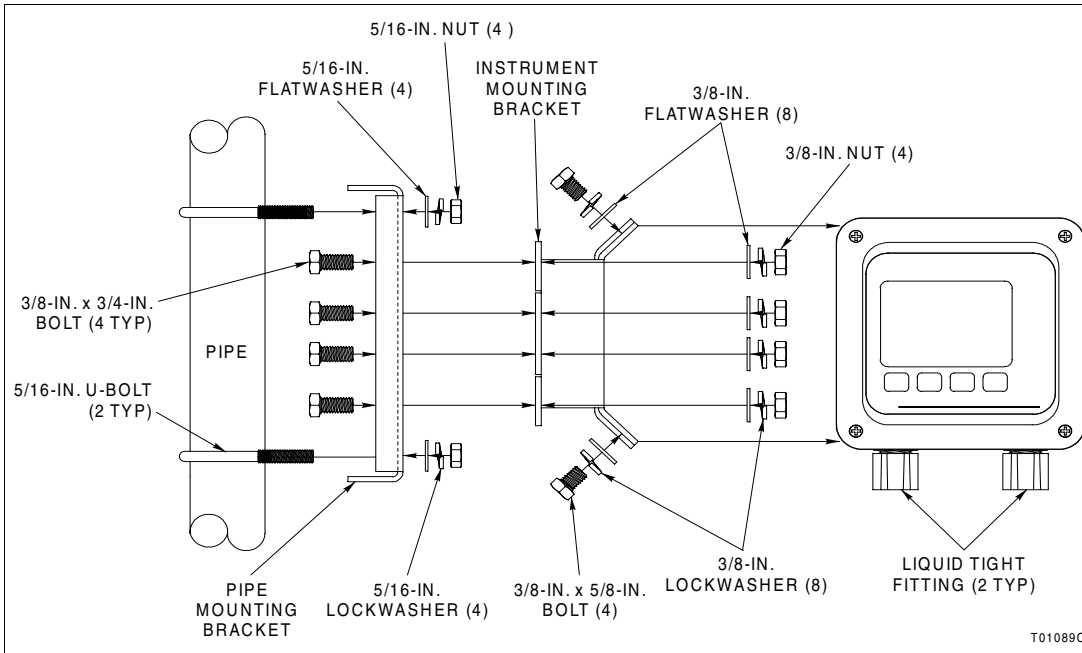

Figure PR1-1. Pipe Mounting

- 6. Use the four $\frac{3}{8}$ -inch x $\frac{3}{4}$ -inch bolts, $\frac{5}{16}$ -inch flatwashers, and $\frac{5}{16}$ -inch lockwashers to attach the transmitter to the instrument mounting bracket.

NOTE: The transmitter has four sets of threaded mounting holes to accommodate positioning the transmitter in any of four orientations.

- 7. Tighten the hardware using the crescent wrench.

PROCEDURE PR2 - PANEL MOUNTING

PURPOSE/SCOPE

30 min.

This procedure describes how to mount the transmitter into a panel using panel mounting kit 4TB9515-0123.

Parts

Number	Qty	Description
4TB4704-0048	4	Screw, hex, $\frac{3}{8}$ -16 x $\frac{1}{2}$ -in.
4TB4704-0118	4	Screw, panel mounting
4TB4710-0022	4	Lockwasher, split, $\frac{3}{8}$ -in.
4TB4906-0019	1	Gasket, panel
4TB5205-0292	4	Bracket, panel mounting

Tools

- Tools for making panel cutout (dependent on installation).
- Flat-blade screwdriver.
- Crescent wrench.

PROCEDURE

The panel mounting kit contains four panel mounting bracket assemblies and a panel gasket. The transmitter enclosure conforms to DIN sizing. Figure PR2-1 shows the required panel cutout, maximum panel thickness, and minimum panel depth.

1. Select the location and orientation of the transmitter.
2. Use suitable tools (dependent on installation) to make a 135.4 (+1.3, -0.8) by 135.4 (+1.3, -0.8) mm (5.33 (+0.05, -0.03) by 5.33 (+0.05, -0.03)) in. cutout with diagonal corners as shown in Figure PR2-1.
3. Install the panel gasket onto the transmitter.
4. Install the transmitter into the panel cutout.
5. Use the crescent wrench and four $\frac{3}{8}$ -16 x $\frac{1}{2}$ -in. hex screws and $\frac{3}{8}$ -in. lockwashers to attach the panel mounting brackets to all four corners of the transmitter.
6. Use the flat-blade screwdriver to tighten the panel mounting screws on the panel mounting bracket until the transmitter seats tightly against the panel.

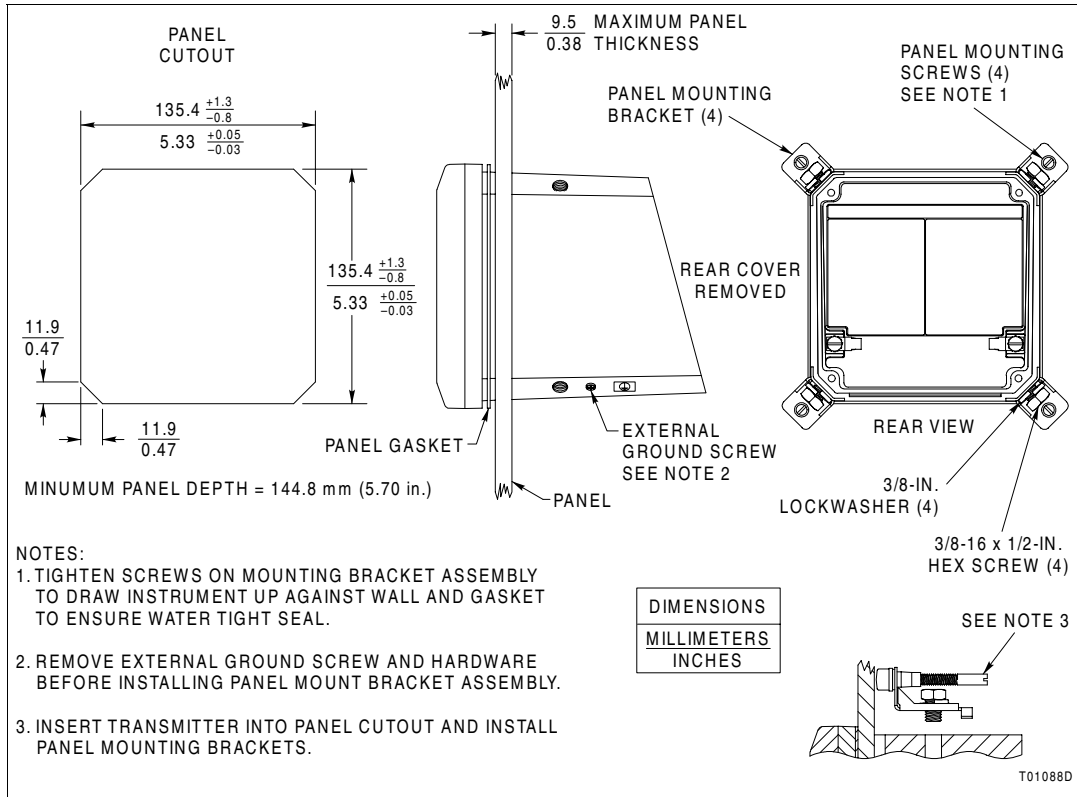

Figure PR2-1. Panel Mounting

PROCEDURE PR3 - WALL MOUNTING

PURPOSE/SCOPE

30 min.

This procedure describes how to mount the transmitter to a wall or other suitable surface using wall mounting kit 4TB9515-0123.

Parts

Number	Qty	Description
4TB4704-0119	4	Bolt, $\frac{3}{8}$ -in. x $\frac{5}{8}$ -in.
4TB4710-0022	4	Lockwasher, $\frac{3}{8}$ -in.
4TB4710-0028	4	Flatwasher, $\frac{3}{8}$ -in.
4TB5008-0071	1	Bracket, instrument mounting
Customer-supplied	A/R	Fitting, liquid tight
Customer-supplied	A/R	Fasteners for wall

Tools

- Tools for mounting instrument mounting bracket to wall (dependent on installation).
- Crescent wrench.

PROCEDURE

The wall mounting kit contains an instrument mounting bracket and associated hardware. Wall mounting accommodates installations where the transmitter can be positioned for a clear line of sight and free access to the rear terminations. These types of installations include supporting beams, flange brackets, and wall ends.

1. Select the location and orientation of the transmitter.
2. Refer to Figure **PR3-1** and attach the instrument mounting bracket to the selected location using the appropriate type of fastener based on the material of the wall.
3. Use four $\frac{3}{8}$ -inch x $\frac{5}{8}$ -inch bolts, $\frac{3}{8}$ -inch flat washers, and $\frac{3}{8}$ -inch lockwashers to attach the transmitter to the instrument mounting bracket.

NOTE: The transmitter has four sets of threaded mounting holes to accommodate positioning the transmitter in any of four orientations.

4. Tighten the hardware using the crescent wrench.

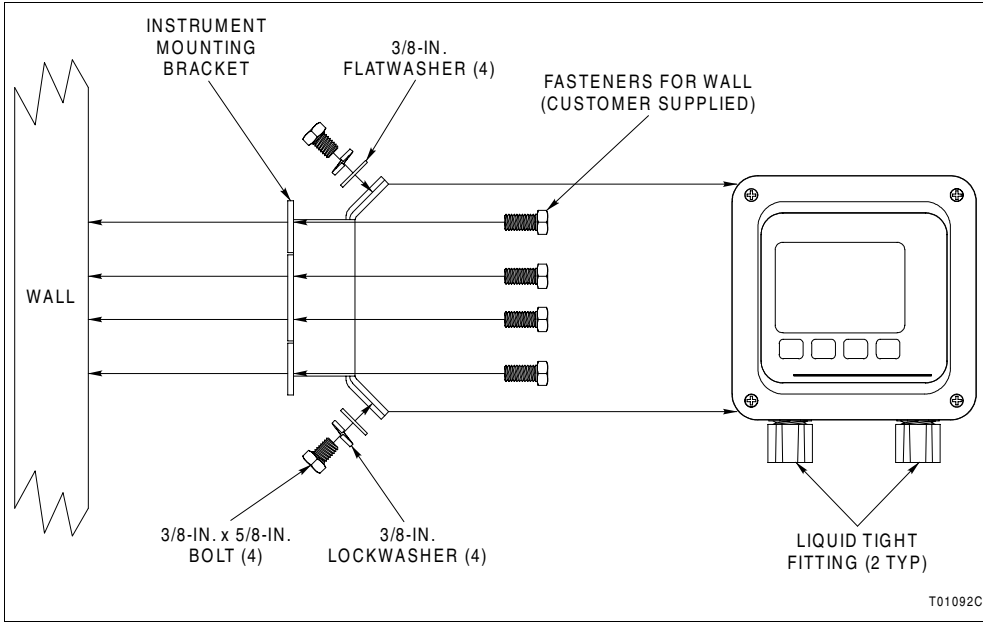

Figure PR3-1. Wall Mounting

PROCEDURE PR4 - HINGE MOUNTING

PURPOSE/SCOPE

30 min.

This procedure describes how to mount the transmitter to a wall or other suitable surface using hinge mounting kit 4TB9515-0125.

Parts

Number	Qty	Description
4TB4704-0048	4	Bolt, $\frac{3}{8}$ -in. x $\frac{5}{8}$ -in.
4TB4704-0086	8	Bolt, $\frac{3}{8}$ -in. x $\frac{3}{4}$ -in.
4TB4710-0022	12	Lockwasher, $\frac{3}{8}$ -in.
4TB4710-0028	12	Flatwasher, $\frac{3}{8}$ -in.
4TB4711-0020	8	Nut, $\frac{3}{8}$ -in.
4TB5008-0071	1	Bracket, instrument mounting
4TB5008-0073	1	Bracket, L
4TB5010-0005	1	Hinge, stainless steel
Customer-supplied	A/R	Fitting, liquid tight
Customer-supplied	A/R	Fasteners for mounting surface

Tools

- Tools for mounting L-bracket to mounting surface (dependent on installation).
- Crescent wrench.

PROCEDURE

The hinge mounting kit contains an L bracket, an instrument mounting bracket, a stainless steel hinge, and associated hardware. The hinge mounting kit allows free access to the rear of the transmitter.

1. Select the location and orientation of the transmitter.
2. Refer to Figure **PR4-1** and attach the L-bracket to the selected location using the appropriate type of fastener based on the material of the mounting surface.
3. Use four of the $\frac{3}{8}$ -inch x $\frac{3}{4}$ -inch bolts, $\frac{3}{8}$ -inch flat washers, $\frac{3}{8}$ -inch lockwashers, and $\frac{3}{8}$ -inch nuts to attach the hinge to the L-bracket.
4. Tighten the hardware using the crescent wrench.
5. Use four $\frac{3}{8}$ -inch x $\frac{3}{4}$ -inch bolts, $\frac{3}{8}$ -inch flat washers, $\frac{3}{8}$ -inch lockwashers, and $\frac{3}{8}$ -inch nuts to attach the instrument mounting bracket to the hinge.

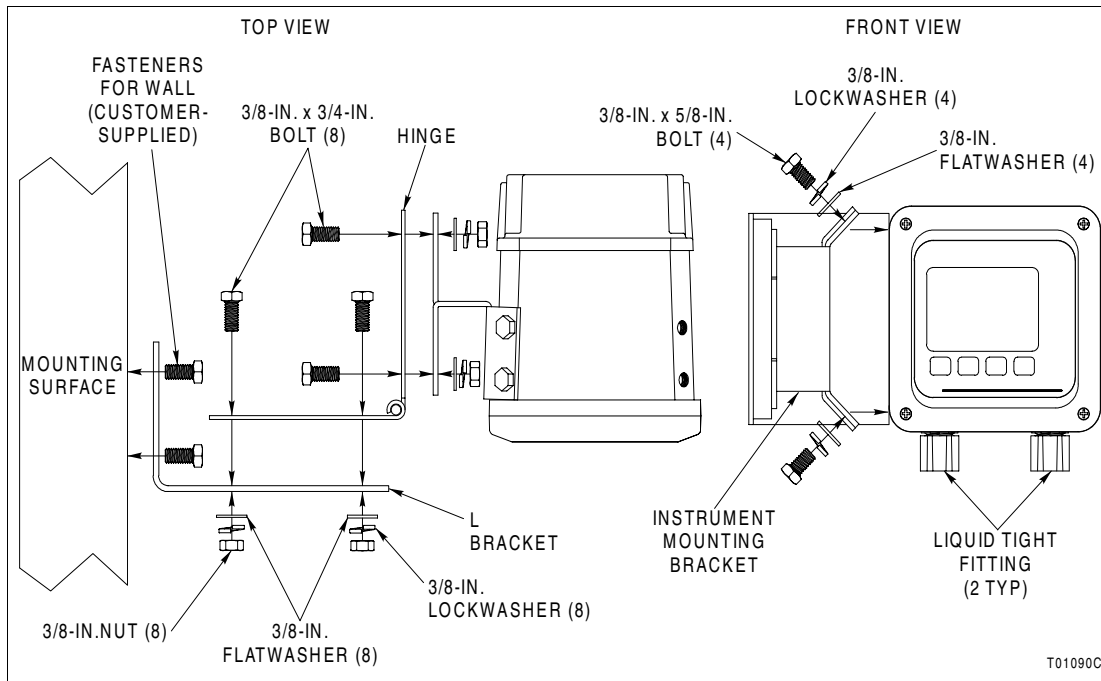

Figure PR4-1. Hinge Mounting

- 6. Tighten the hardware using the crescent wrench.
- 7. Use four $\frac{3}{8}$ -inch x $\frac{5}{8}$ -inch bolts, $\frac{3}{8}$ -inch flat washers, and $\frac{3}{8}$ -inch lockwashers to attach the transmitter to the instrument mounting bracket.

NOTE: The transmitter has four sets of threaded mounting holes to accommodate positioning the transmitter in any of four orientations.

- 8. Tighten the hardware using the crescent wrench.

PROCEDURE PR5 - WIRING AND GROUNDING

PURPOSE/SCOPE

10 min.

This procedure describes how to connect the signal and power wiring, and sensor wiring, and shows the internal and external ground connections.

Parts None.

Tools

- Flat-blade screwdriver.
- Small flat-blade screwdriver.

PROCEDURE

Use shielded wire and separate conduit for the signal/power wiring, and the sensor wiring. Under ideal conditions, this may not be required; however, it minimizes the chance of problems from noise and signal degradation.

Just prior to entering the housing, terminate rigid conduit and install a short length of flexible conduit. This reduces stress to the housing.

Signal/Power Wiring

The power and output signals share the same pair of wires. This wiring must bear a suitable voltage rating and be rated to at least 75-degrees Celsius (167-degrees Fahrenheit). All wiring and wiring practices must be in accordance with the National Electric Code (NEC), Canadian Electrical Code (CEC), or other applicable local or international codes for the country where the transmitter will be installed.

The signal terminals, located at the rear of the transmitter, accept wire sizes from 12 to 24 AWG. ABB Instrumentation recommends pin-style terminals for all connections.

A terminal block (TB1) label is marked POWER for the signal connections and shows the polarity. Wiring should not be run in conduit or open trays where AC power wiring or heavy electrical equipment could contact or physically and electrically interfere with the signal wiring. Twisted, shielded pairs should be used for cabling to insure the best performance. Reverse polarity protection, built into the transmitter, protects it against damage from accidental reversal of the field wiring connections.

All power passes over the signal leads. The maximum supply voltage is 53 VDC (42 VDC for certified applications). Minimum

supply voltage is determined by the loop resistance (Fig. PR5-1) as follows:

For standard transmitters:

$$\text{min supply voltage (VDC)} = 13 \text{ VDC} + (0.020 \text{ A} \times \text{total R in ohms})$$

For HART transmitters:

$$\text{min supply voltage (VDC)} = 13.5 \text{ VDC} + (0.020 \text{ A} \times \text{total R in ohms})$$

NOTES:

1. Add 0.5 VDC to all minimum supply voltage values if using the lightning arrestor option.
2. Add 1.0 VDC to all minimum supply voltage values when the shorting jumper is removed from the TEST terminals.

The load resistance must include any meters external to the transmitter, the wiring, and the system input.

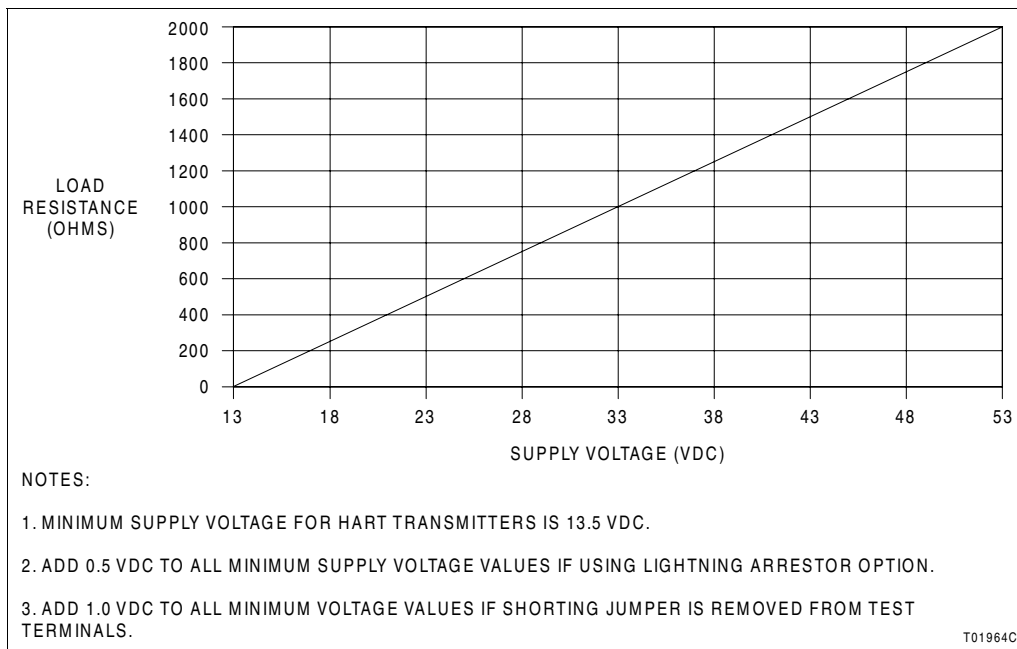

Figure PR5-1. Load Limits

- 1. Use the flat-blade screwdriver to loosen the four captive screws that secure the rear cover to the transmitter.
- 2. Use the small flat-blade screwdriver to connect the signal and power wiring to TB1-1 (+) and TB1-2 (-) as shown in Figure PR5-2.
- 3. Leave the rear cover off to continue with sensor wiring.

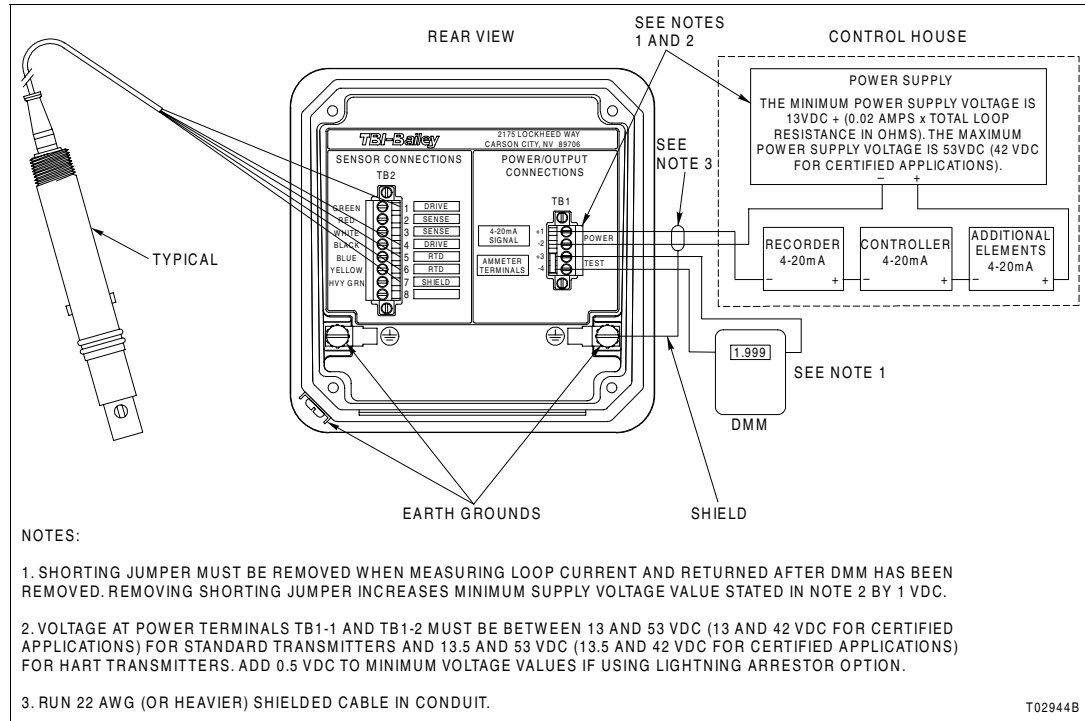

Figure PR5-2. Wiring and Grounding

Sensor Wiring

The sensor wiring connects to the rear of the transmitter. The terminals accept wire sizes from 12 to 24 AWG. ABB Instrumentation recommends pin-style terminals for all connections. Run sensor wiring in shielded conduit, or similar, to protect it from environmental influences. Do not allow the wires to become wet or lie on the ground or over any other equipment. Insure there is no abrading, pinching, or bending of the cables at installation.

The sensor leads are color coded and have the functions listed in Table PR5-1.

- 1. Use the small flat-blade screwdriver to connect the sensor wiring as shown in Figure PR5-2.
- 2. Install the rear cover and tighten the captive screws with the flat-blade screwdriver.

Table PR5-1. Sensor Connections

Terminal	Color Code	Function
TB2-1	Green	Drive
TB2-2	No connection	No connection
TB2-3	No connection	No connection
TB2-4	Black	Drive
TB2-5	Blue	RTD
TB2-6	Yellow	RTD
TB2-7	Heavy green	Shield
TB2-8	No connection	No connection

Grounding

Signal wiring should be grounded at any one point in the signal loop, preferably before signal processing occurs. It may be left ungrounded (floating) if electrical noise is minimal. Ground the transmitter enclosure to an earth ground having less than 0.2 ohms of resistance. Internal and external earth ground terminals are provided and are shown in Figure [PR5-2](#).

PROCEDURE PR6 - TEMPERATURE CALIBRATION

PURPOSE/SCOPE

20 min.

This procedure describes how to perform a temperature calibration.

Parts None.

Tools

- Temperature measuring device.

PROCEDURE

The temperature calibration state is a smart calibration routine that allows for single-point and dual-point calibrations. Calibrating the temperature at two points that are at least 20-degrees Celsius apart causes the transmitter to automatically adjust the temperature sensor offset, slope, or both. Since this routine only uses the most recent calibration data, calibration can be conducted throughout the life of the sensor. This ensures consistent performance. The reset calibration state restores the calibration to factory settings in the event of bad calibration data. The reset calibration state is discussed in [PR10](#).

NOTE: The reset calibration state resets all calibration values including the process and temperature sensors; therefore, the process and temperature sensors require calibration after performing the reset calibration procedure.

1. Before installing the sensor into its final installed location, allow it to reach ambient temperature.
2. Press the *MENU* smart key until *CALIBRATE* is highlighted on the display.
3. Press the *SELECT* smart key to enter the calibrate state.
4. Press the *NEXT* smart key until *TMP.CAL* appears on the display.
5. Press the *SELECT* smart key to start the temperature calibration procedure.
6. The transmitter displays *STABL?*. Observe the displayed reading. If it is stable, press the *YES* smart key. If it is not stable, press the *NO* smart key. If *NO* is selected, the transmitter returns to the temperature calibration state. Perform Steps 7 through 9. If *YES* is selected, go to Step 10.

- 7. If the ambient or process liquid temperature has become unstable, wait until the process temperature stabilizes.
- 8. Check to see if the transmitter has detected a fault condition by looking for the *FAULT* icon on the display. Interrogate the fault by escaping to the measure mode through the *exit to MEASURE* smart key and then pressing the *FAULT info* smart key in that order.
- 9. Refer to **Section 12** for information on problem and error codes.
- 10. The transmitter asks for the *NEW VAL*. Use the temperature measuring device to measure the ambient temperature and enter that value into the *NEW VAL*. screen.
 - a. Use the smart key to increment the value of the blinking digit.
 - b. When the first digit value is correct, use the smart key to move to the next digit.
 - c. Repeat Steps 10a and 10b for each digit.
 - d. Press the *ENTER* smart key to accept the new value.
- 11. For an existing installation where a two-point calibration is desired, wait for the process liquid temperature to change to 20°C. When the process liquid temperature has stabilized, go to Step 6. For a new installation, mount the sensor in its final installed location and allow it to reach the process liquid temperature. When the sensor and process liquid have stabilized, go to Step 5.

PROCEDURE PR7 - PV CALIBRATION

PURPOSE/SCOPE

10 min.

This procedure describes how to perform a PV (conductivity/concentration) calibration.

Parts None.

Tools

- External instrument having the same type of temperature compensation as the transmitter.
- Grab sample of process liquid.

PROCEDURE

The conductivity/concentration calibration state is a smart one-point calibration routine. It allows for single-point and dual-point calibrations. Initiating calibrations at two different conductivity values having ample separation allows the transmitter to automatically adjust the offset, slope, or both. This insures the best sensor performance. Since this routine uses only the latest calibration data, calibration can be conducted throughout the life of the sensor insuring consistent sensor performance.

If an incorrect calibration has been entered, the reset calibration state provides the ability to return transmitter calibration to those set at the factory.

NOTE: The reset calibration state resets all calibration values, including the process and temperature sensors. Process and temperature calibrations must be performed after a calibration reset.

The transmitter is configurable as a conductivity or concentration transmitter. The smart one-point calibration routines automatically set the units of calibration to be the same as those for the measured process variable.

1. Make sure the sensor is in its final installed location and orientation.
2. Measure the PV value, using an external instrument having the same type of temperature compensation as the transmitter and a grab sample.
3. Record the value displayed on the transmitter at the time the grab sample was taken and the value displayed on the external instrument.
4. Press the *MENU* smart key until *CALIBRATE* is highlighted on the display.

- 5. Press the *SELECT* smart key to enter the calibrate state.
- 6. Press the *NEXT* smart key until *CON.CAL* appears on the display.
- 7. Press the *SELECT* smart key to start the one-point calibration procedure.
- 8. The transmitter displays *STABL?*. Observe the displayed reading. If it is stable, press the *YES* smart key. If it is not stable, press the *NO* smart key. If *NO* is selected, the transmitter returns to the process sensor calibration state. Perform Steps 9 through 11. If *YES* is selected, go to Step 12.
- 9. Wait until the process liquid composition stabilizes.
- 10. Check to see if the transmitter has detected a fault condition by looking for the *FAULT* icon on the display. Interrogate the fault by escaping to the measure mode through the *exit to MEASURE* smart key and then pressing the *FAULT info* smart key in that order.
- 11. Refer to **Section 12** for information on problem and error codes.
- 12. The transmitter displays *NEW VAL*.
 - a. Calculate the new process variable value by subtracting the transmitter value recorded in Step 3 from the external instrument value recorded in Step 3 and then adding that result to the current value displayed on the transmitter.
 - b. Use the smart key to increment the value of the blinking digit.
 - c. When the first digit value is correct, use the smart key to move to the next digit.
 - d. Repeat Steps 12b and 12c for each digit.
 - e. Press the *ENTER* smart key to accept the new value.
- 13. If the entered calibration value is not valid, the transmitter displays *BAD.CAL*, and the calibration value is rejected. If the entered calibration value is valid, the slope (sensor efficiency) appears on the display. Press the *NEXT* smart key to display the offset.
- 14. Press the *NEXT* smart key to return to the conductivity/concentration calibration state or press the *exit to MEASURE* smart key to go to the measure mode.

NOTE: If an output hold condition is present, the display inquires if this condition should be released.

PROCEDURE PR8 - OUTPUT CALIBRATION

PURPOSE/SCOPE

10 min.

This procedure describes how to calibrate the transmitter output values using an external validation device.

Parts None.

Tools

- Digital multimeter (DMM).
- Flat-blade screwdriver.
- Small flat-blade screwdriver.

PROCEDURE

The output calibrate state trims the output signal to maintain precise transmission of the PV to the final monitoring system. The transmitter output current is factory calibrated; however, the output can be trimmed to compensate for other input and output devices.

1. Use the flat-blade screwdriver to loosen the four captive screws that secure the rear cover to the transmitter.
2. Use the small flat-blade screwdriver to remove the shorting jumper from the test terminals, TB1-3 (+) and TB1-4 (-), as shown in Figure PR8-1.
3. Connect the DMM, set to measure mA, to the TEST terminals, TB1-3 (+) and TB1-4 (-).
4. Press the *MENU* smart key until *CALIBRATE* is highlighted on the display.
5. Press the *SELECT* smart key to enter the calibrate state.
6. Press the *NEXT* smart key until *OUT.CAL* appears on the display.
7. Press the *SELECT* smart key to start the output calibration procedure.
8. Use the and smart keys to adjust the output so that the DMM reads 4.0 mA.
9. Press the *ENTER* smart key to enter the new value and proceed to the 20-mA output.
10. Use the and smart keys to adjust the output so that the DMM reads 20.0 mA.

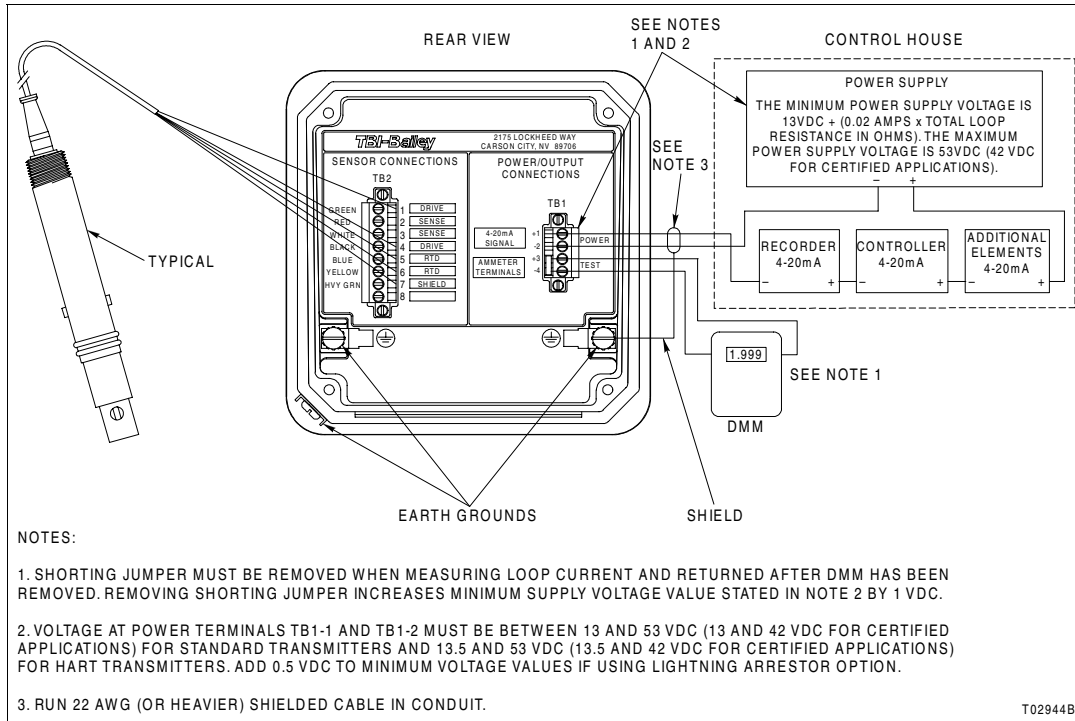

Figure PR8-1. Output Calibration Setup

- 11. Press the *ENTER* smart key to enter the new value. The transmitter returns to the output calibration state.

NOTE: Once the output level has been permanently stored using the *ENTER* smart key, the output calibration procedure must be repeated to rectify a bad calibration.

- 12. Press the *exit to MEASURE* smart key to return to the measure mode.

PROCEDURE PR9 - EDIT CALIBRATION

PURPOSE/SCOPE

5 min.

This procedure describes how to edit the process sensor and temperature sensor offset and slope values.

Parts None.



Tools None.



PROCEDURE



The edit calibration state allows manual adjustment of the process sensor and temperature sensor slope and offset values. This function may not be suitable for many applications, but it facilitates quick and easy access to these calibration values for troubleshooting purposes.

This procedure can also be used when setting up multiple transmitters with similar installation parameters. After the first transmitter has been calibrated, the slope and offset values can be retrieved and programmed into the other transmitters to be put into service.

1. Press the *MENU* smart key until *CALIBRATE* is highlighted on the display.
2. Press the *SELECT* smart key to enter the calibrate state.
3. Press the *NEXT* smart key until *EDT.CAL* appears on the display.
4. Press the *SELECT* smart key to start the edit calibration procedure.
5. The transmitter displays the process sensor slope. Valid slope values range from 0.20 to 5.00.
 - a. Use the smart key to increment the value of the blinking digit.
 - b. When the first digit value is correct, use the smart key to move to the next digit.
 - c. Repeat Steps 5a and 5b for each digit.
 - d. Press the *ENTER* smart key to accept the new value and edit the sensor offset. To continue, go to Step 6. To end the procedure, press the *exit to MEASURE* smart key.

- 6. The transmitter displays the process sensor offset. The valid offsets range from -20 to +20 $\mu\text{S}/\text{cm}$ for a nominal sensor cell constant value of 1.00, -4 to +4 $\mu\text{S}/\text{cm}$ for a nominal sensor cell constant value of 0.10, and -0.8 to +0.8 $\mu\text{S}/\text{cm}$ for a nominal sensor cell constant value of 0.01
 - a. Use the  smart key to increment the value of the blinking digit.
 - b. When the first digit value is correct, use the  smart key to move to the next digit.
 - c. Repeat Steps 6a and 6b for each digit.
 - d. Press the *ENTER* smart key to accept the new value and edit the temperature slope. To continue, go to Step 7. To end the procedure, press the *exit to MEASURE* smart key.

- 7. The transmitter displays the temperature sensor slope. Valid slope values range from 0.2 to 1.5.
 - a. Use the  smart key to increment the value of the blinking digit.
 - b. When the first digit value is correct, use the  smart key to move to the next digit.
 - c. Repeat Steps 7a and 7b for each digit.
 - d. Press the *ENTER* smart key to accept the new value and edit the temperature offset. To continue, go to Step 8. To end the procedure, press the *exit to MEASURE* smart key.

- 8. The transmitter displays the temperature sensor offset. Valid offset values range from -40°C to +40°C.
 - a. Use the  smart key to increment the value of the blinking digit.
 - b. When the first digit value is correct, use the  smart key to move to the next digit.
 - c. Repeat Steps 8a and 8b for each digit.
 - d. Press the *ENTER* smart key to accept the new value and go back to the edit calibration state. To end the procedure, press the *exit to MEASURE* smart key.

PROCEDURE PR10 - RESET CALIBRATION

PURPOSE/SCOPE

1 min.

This procedure describes how to restore process sensor and temperature sensor calibration values to the factory values.

Parts None.

Tools None.

PROCEDURE

The reset calibration state sets all process sensor and temperature sensor calibration data to the values set at the factory. This state allows the purging of all calibration history and the start of a new history. The reset sets the process sensor and temperature sensor slope values to 1.000, and the process sensor and temperature sensor offset values to 0.000.

1. Press the *MENU* smart key until *CALIBRATE* is highlighted on the display.
2. Press the *SELECT* smart key to enter the calibrate state.
3. Press the *NEXT* smart key until *RST.CAL* appears on the display.
4. Press the *SELECT* smart key to start the reset calibration procedure.
5. The display reads *RESET?*. Press the *YES* smart key to confirm the reset or the *NO* smart key to refuse the reset.

NOTE: The reset calibration state resets all sensor and temperature calibration values; therefore, the process sensor and temperature sensor require calibration after performing the reset calibration procedure.

PROCEDURE PR11 - OUTPUT/HOLD MODE

PURPOSE/SCOPE

5 min.

This procedure describes how to use the output/hold mode.

Parts None.

Tools None.

PROCEDURE

The output/hold mode consists of five states of operation.

Hold Output

The hold state allows the transmitter output to be fixed at a level captured upon initiation of the hold or to be manually adjusted to any value between zero and 100 percent (four and 20 milliamperes).

- 1. Press the *MENU* smart key until *OUT/HOLD* is highlighted.
- 2. Press the *SELECT* smart key to enter the output/hold mode.
- 3. Press the *NEXT* smart key until *HOLD* appears.
- 4. Press the *SELECT* smart key to start the hold output procedure.
- 5. To accept the current hold value, press the *ENTER* smart key and the transmitter automatically goes to the measure mode. To adjust the current hold value, do not press the *ENTER* smart key and continue with Step 6.
- 6. Press the smart key to increment the blinking digit to the desired value.
- 7. Press the smart key to move to the next digit.
- 8. Repeat Steps 6 and 7 for each digit.
- 9. Press the *ENTER* soft key to accept the new value.
- 10. When the process is complete, the transmitter automatically goes to the measure mode.

Release Hold

The hold state is used to release a hold condition that already exists.

- 1. Verify that *OUTPUT HELD* appears in the upper left corner of the display.
- 2. Press the *MENU* smart key until *OUT/HOLD* is highlighted.
- 3. Press the *SELECT* smart key to enter the output/hold mode.
- 4. Press the *NEXT* smart key until *HOLD* appears.
- 5. Press the *SELECT* smart key to start the release hold output procedure.
- 6. The transmitter display reads *REL.HLD*. Press the *YES* smart key to release the hold output condition or the *NO* smart key to continue to hold the output.
- 7. When the process is complete, the transmitter automatically goes to the measure mode.

Rerange Output

The rerange state provides the ability to change the output range. Change one or both endpoint values to any value or range of values that are within those listed in Table **PR11-1**.

Table PR11-1. Output Ranges

Input Type	Output Range
Concentration	0.000 to 1,999 digits (engineering unit configurable)
Conductivity	
Cell constant = 0.01	0.000 to 199.9 $\mu\text{S/cm}$
Cell constant = 0.10	0.000 to 1,999 $\mu\text{S/cm}$
Cell constant = 1.00	0.000 to 19.99 ms/cm

- 1. Press the *MENU* smart key until *OUT/HOLD* is highlighted.
- 2. Press the *SELECT* smart key to enter the output/hold mode.
- 3. Press the *NEXT* smart key until *RERNGE* appears.
- 4. Press the *SELECT* smart key to start the rerange procedure.

- 5. Edit the process variable value for the four-mA point.
 - a. Press the smart key to increment the blinking digit to the desired value.
 - b. Press the smart key to move to the next digit or unit of conductivity.
 - c. Repeat Steps 6a and 6b for each digit or unit of conductivity.
- 6. Press the *ENTER* smart key to accept the new value and continue to the process variable value for the 20-mA point.
- 7. Press the *exit to MEASURE* smart key to escape to the measure mode or continue with the procedure to adjust the process variable value for the 20-mA point.

NOTE: If the four-mA value is changed and accepted using the *ENTER* smart key, the value is valid per those shown in Table **PR11-1**, and the transmitter is returned to the measure mode by pressing the *exit to MEASURE* smart key without adjusting the 20-mA value, the output range will only reflect the new four-mA point and keep the existing 20-mA point.

- 8. Edit the process variable value for the 20-mA point.
 - a. Press the smart key to increment the blinking digit to the desired value.
 - b. Press the smart key to move to the next digit or unit of conductivity.
 - c. Repeat Steps 8a and 8b for each digit or unit of conductivity.
- 9. Press the *ENTER* smart key to accept the new value.
- 10. When the process is complete, the transmitter automatically goes to the measure mode.

Damping

The damping state applies a lag function on the output signal and reduces fluctuations caused by erratic process conditions. The damping value is adjustable from 00.0 to 99.9 seconds. This value represents the time required for the output to reach approximately 63.2 percent of its final value in response to a step change in PV input.

- 1. Press the *MENU* smart key until *OUT/HOLD* is highlighted.
- 2. Press the *SELECT* smart key to enter the output/hold mode.

- 3. Press the *NEXT* smart key until *DAMPNG* appears.
- 4. Press the *SELECT* smart key to start the damping procedure.
 - a. Use the smart key to increment the value of the blinking digit.
 - b. When the first digit value is correct, use the smart key to move to the next digit.
 - c. Repeat Steps 4a and 4b for each digit.
 - d. Press the *ENTER* smart key to accept the new value.
- 5. When the process is complete, the transmitter automatically goes to the measure mode.

Output Spike Toggle

The spike state toggles the operational state of the spike output function. The spike function modulates the current output by the amount set in the transmitter configuration. This function is only available for transmitters with advanced programming.

- 1. Press the *MENU* smart key until *OUT/HOLD* is highlighted.
- 2. Press the *SELECT* smart key to enter the output/hold mode.
- 3. Press the *NEXT* smart key until *SPIKE* appears.
- 4. Press the *SELECT* smart key to start the spike output procedure.
- 5. Toggle the spike output function to the desired state (*ON* or *OFF*) by using the smart key to toggle between *ON* and *OFF*.
- 6. Press the *ENTER* smart key to select the desired state.
- 7. When the process is complete, the transmitter automatically goes to the measure mode.

NOTE: Once the spike state is *OFF*, changing the configured spike level in the configure mode will not enable the spike state. The spike state can only be turned *ON* or *OFF* in the output/hold mode.

PROCEDURE PR12 - SELECTING VIEW OR MODIFY CONFIGURATION STATE

PURPOSE/SCOPE

1 min.

This procedure describes how to select whether to view or modify the configuration.

Parts None.

Tools None.

PROCEDURE

When the configure mode is selected, a decision point is reached to determine whether to view or modify the configuration. The modify configure state enables transmitter options to be set and saved into memory. In order to provide the ability to secure the modify configure state, yet leave the ability to view configuration information, the view configure state can be entered without using a password.

- 1. Press the *MENU* smart key until *CONFIGURE* is highlighted on the display.
- 2. Press the *SELECT* smart key to enter the configure mode.
- 3. The *MODIFY* screen appears. Press the *YES* smart key to modify the configuration and go to the next procedure in the flow. Press the *NO* smart key to view the configuration and go on to Step 4.
- 4. The *VIEW* screen appears. Press the *YES* smart key to view the configuration.
- 5. To view the configuration only, perform Steps 6 and 7. To modify the configuration, go to the next procedure in the flow.
- 6. Press the *NEXT* smart key to scroll through the configuration.
- 7. At any time during the viewing of the configuration, press the *exit to MEASURE* smart key to go back to the measure mode.

PROCEDURE PR13 - MODIFYING CONFIGURATION WHILE VIEWING

PURPOSE/SCOPE

1 min.

This procedure describes how to modify the configuration while in the view configure state.

Parts None.

Tools None.

PROCEDURE

If a configuration requires modification while in the view configuration state, access to the modify configure state is provided through the *ENTER* smart key.

- 1. Press the *NEXT* smart key to scroll through the configuration until the parameter that requires changing appears.
- 2. Press the *ENTER* smart key to modify that parameter.
- 3. A *MODIFY?* screen appears. Press the *YES* smart key to modify the parameter.
- 4. Enter the password if the configure mode is password protected.
- 5. Modify the desired parameter using the proper procedure.
- 6. Press the *exit to MEASURE* smart key.
- 7. When the *SAVE?* screen comes up, press the *YES* smart key to accept the change. Press the *NO* smart key to abort the change. In either case, the transmitter goes to the measure mode.

PROCEDURE PR14 - PROGRAMMING MODE CHANGE

PURPOSE/SCOPE

1 min.

This procedure describes how to change the programming mode from advanced to basic or from basic to advanced for transmitters with the advanced programming option.

Parts None.

Tools None.

PROCEDURE

The configure mode is split into two programming modes: basic and advanced. These two options are specified by nomenclature and control the number of configuration options available in the modify configure mode.

The basic programming mode contains a subset of configuration options found in the advanced programming mode. Separation into two programming groups is advantageous when limited functionality is desired. Fewer options reduces confusion and the possibility of configuration errors.

Transmitters ordered with the advanced programming option can be changed between basic and advanced programming. Transmitters ordered with the basic programming option require an update password to change to advanced programming. Contact ABB Instrumentation to obtain the password.

The programming toggle (*BASIC* or *ADVNC*) for transmitters with the advanced programming option must be set in two locations: user state in the utility mode and modify configure state in the configure mode. In order to select either the basic or advanced programming mode in the modify configure state, the programming mode must be set to advanced in the user state.

- 1. The *BASIC* screen appears. Press the *ENTER* smart key to set the programming to basic and advance to the modify configure states or press the *NEXT* smart key to advance to the next screen and go on to Step 2.
- 2. The *ADVNC* screen appears. Press the *ENTER* smart key to set the programming to advanced and advance to the modify configure states.

PROCEDURE PR15 - ANALYZER AND SENSOR CELL CONSTANT TYPE SELECTIONS

PURPOSE/SCOPE

2 min.

This procedure describes how to configure the analyzer state and sensor cell constant. These settings are available in both the basic and advanced programming modes.

Parts None.



Tools None.

PROCEDURE

The analyzer state determines the transmitter and sensor cell constant types. Table PR15-1 describes the function and programming mode of each analyzer state.

Table PR15-1. Analyzer States

State	Display	Programming Mode	Function
Concentration	CONCEN	Advanced	Used to measure conductivity of a solution and convert nonspecific measurement to specific solute concentration. Process variable engineering units are %, ppm, ppb, and user-defined.
Conductivity	COND	Basic and Advanced	Used to measure conductivity of a solution. Process variable engineering units are $\mu\text{S}/\text{cm}$ and mS/cm .

- 1. Press the *SELECT* smart key to modify the analyzer state.
- 2. If this is a basic configuration, the transmitter goes directly to the sensor cell constant screen. Go to Step 5. If this is an advanced configuration, continue with Step 3.
- 3. The currently configured analyzer state appears. Press the *NEXT* smart key until the desired analyzer state appears.
- 4. Press the *ENTER* smart key to accept the new value.
- 5. The current cell constant appears. To change it:
 - a. Use the  smart key to increment the value of the blinking digit.
 - b. When the first digit value is correct, use the  smart key to move to the next digit.
 - c. Repeat Steps 5a and 5b for each digit.
 - d. Press the *ENTER* smart key to accept the new value.

PROCEDURE PR16 - CONCENTRATION PROGRAMMING

PURPOSE/SCOPE

15 min.

This procedure describes how to program the user-defined concentration configuration. This function is only available in the advanced programming mode and applies to the concentration analyzer state.

Parts None.

Tools None.

PROCEDURE

The concentration state converts conductivity values to concentration units. This state applies temperature compensated conductivity measurements to a user-defined function. This function converts conductivity measurements to concentration values having a fixed decimal point location so that decimal point ranging will not occur.

The user-defined configuration provides the capability of selecting an engineering unit icon, the decimal point position, a custom text description, and a six-point linear curve fit.

Engineering Unit Icon

The concentration state allows for conversion of conductivity inputs to concentration units such as percent, parts per million (ppm), and parts per billion (ppb). It is also possible to select no engineering unit icon.

- 1. Press the *NEXT* smart key until the desired engineering unit icon appears.
- 2. Press the *ENTER* smart key to accept the new value.

Decimal Point Location

- 1. Press the  smart key to move the decimal point to the desired location.
- 2. Press the *ENTER* smart key to accept the new position.

Text String

The text string can be up to six characters consisting of any combination of A through Z, 1 through 9, a space, and a dash.

- 1. Use the smart key to increment the character.
- 2. When the first character is correct, use the smart key to move to the next character.
- 3. Repeat Steps 1 and 2 for each character.
- 4. Press the *ENTER* smart key to accept the text string.

Linear Curve Fit

The six-point linear curve fit sets the endpoint and breakpoint values for the conductivity-to-concentration conversion. The end point values define the full scale output range. The break-points identify the transition points between the five line segments defining the conductivity-to-concentration curve. The beginning of the first and end of the fifth line segment identify the endpoints of the linear approximation and output range.

Table PR16-1 and Figure PR16-1 show example data and the linear approximation.

Table PR16-1. Conductivity-to-Concentration Data

Point	Conductivity ($\mu\text{S/cm}$)	Concentration (%)	Output (mA)
1	0	0	4.0
2	55	5	5.8
3	105	9	7.2
4	195	16	9.7
5	310	28	14.0
6	400	45	20.0

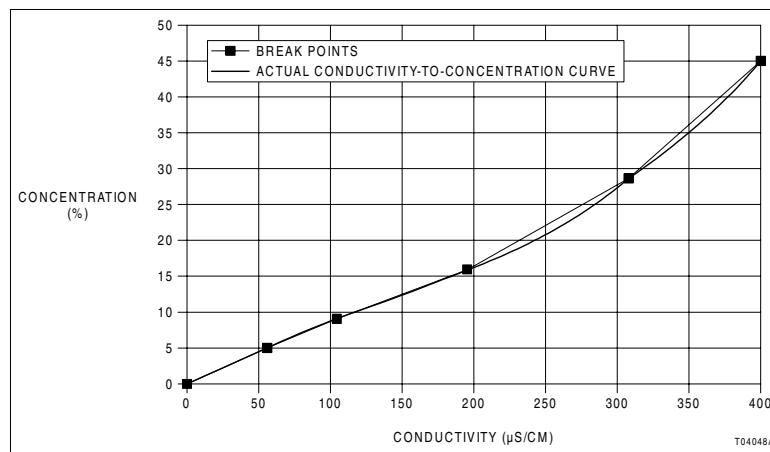

Figure PR16-1. Linear Curve Fit

The curve is a nonlinear function divided into five line segments. The endpoints represent points one and six. The

breakpoints represent points two through five. The transmitter output is linear relative to the solute concentration.

The endpoints define the full scale output range; therefore, rerange of the output is restricted to the range between points one and six. Refer to **Appendix B** for more information on concentration programming.

- 1. Set the first end point conductivity value (*X1.COND*).
 - a. Use the smart key to increment the value of the blinking digit.
 - b. When the first digit value is correct, use the smart key to move to the next digit.
 - c. Repeat Steps 1a and 1b for each digit.
 - d. Press the *ENTER* smart key to accept the new value.
- 2. Set the first end point concentration value (*Y1.CONC*) that represents the endpoint conductivity value entered in Step 1.
 - a. Use the smart key to increment the value of the blinking digit.
 - b. When the first digit value is correct, use the smart key to move to the next digit.
 - c. Repeat Steps 2a and 2b for each digit.
 - d. Press the *ENTER* smart key to accept the new value.
- 3. Repeat Steps 1 and 2 for the four breakpoints and the last endpoint (*X2.COND* through *X6.COND*, and *Y2.CONC* through *Y6.CONC*).
- 4. Press the *NEXT* smart key to go on to the next configuration parameter.

PROCEDURE PR17 - TEMPERATURE SENSOR AND COMPENSATION TYPE SELECTIONS

PURPOSE/SCOPE

2 min.

This procedure describes how to configure the temperature sensor and compensation type states. These settings are available in both the basic and advanced programming modes.

Parts None.

Tools None.

PROCEDURE

The temperature sensor and compensation type states define how the transmitter reacts to temperature changes and their effect on the conductance of solutions.

Temperature Sensor

The temperature sensor state configures the temperature input for a Pt 100, Pt, 1000, three-kilohm Balco RTD, or for no temperature input (none).

- 1. Press the *SELECT* smart key to modify the *TMP.SNS* state.
- 2. The currently configured temperature sensor state appears first. Press the *NEXT* smart key until the desired temperature sensor state appears. Choose between *NONE*, *3K.BLCO*, *PT100*, and *PT1000*.
- 3. Press the *ENTER* smart key to accept the new value.

Temperature Compensation

Temperature has a marked effect on the conductance of many solutions. The effect is generally nonlinear and dependent on the particular ionic species and their concentration.

The transmitter software has a number of preprogrammed correction algorithms that compensate the effect of temperature on conductivity to a reference temperature of 25-degrees Celsius for basic programming or to a user-defined temperature value for advanced programming. This results in accurate and stable measurements when temperature varies.

Options for temperature compensation are grouped into two sets: manual and auto. Manual temperature compensation contains no additional options. It is locked to a specific process temperature independent of the selected temperature

sensor. If desiring a different process temperature, adjust it during a temperature calibration.

Auto temperature compensation options use temperature values measured by the transmitter temperature input. Compensation algorithms include: standard KCl (0.1N KCl based), solution coefficient, pure water neutral salt, pure water trace acid, pure water trace base, and user-defined.

The user-defined temperature compensation option requires uncompensated conductivity data from the reference temperature to the maximum process temperature on a representative sample of process solution. This data is used to calculate the ratio of uncompensated conductivity to conductivity at the reference temperature. These ratios are then plotted against temperature. If a reference temperature other than 25 degrees Celsius is desired the data can be entered in one of two ways.

1. Use ratios referenced to 25°C and adjust the reference temperature to the desired value.
2. Use ratios referenced to the desired value and set the reference temperature at 25°C.

Refer to [Appendix A](#) for more information on temperature compensation.

Table [PR17-1](#) describes the function and programming mode of each state.

Table PR17-1. Temperature Compensation States

State	Display	Programming Mode	Function
Manual	<i>MANUAL</i>	Basic and Advanced	Employed when using fixed temperature value instead of measured value. Initial value is 25°C. Use temperature calibrate state to change fixed temperature value. Compensation is 0.1N KCl based.
Standard potassium chloride (automatic)	<i>STD.KCL</i>	Basic and Advanced	Used when temperature sensor provides measured temperature value. Compensation is 0.1N KCl based (standard).
Temperature compensation coefficient (automatic)	<i>TC.COEF</i>	Basic and Advanced	Used when temperature sensor provides measured temperature value. Compensation is based on percent change of conductivity at reference temperature (e.g., 25°C) per °C. The value is adjustable between 0 and 9.99%/°C.
Pure water neutral salt (automatic)	<i>NEUTRL</i>	Advanced	Used when temperature sensor provides measured temperature value. Compensation pure water with neutral salt based. Restricted to sensor cell constant 0.01.
Pure water trace acid (automatic)	<i>ACID</i>	Advanced	Used when temperature sensor provides measured temperature value. Compensation is pure water with acid based. Restricted to sensor cell constant 0.01.

TEMPERATURE SENSOR AND COMPENSATION TYPE SELECTIONS

Table PR17-1. Temperature Compensation States (continued)

State	Display	Programming Mode	Function
Pure water trace base (automatic)	<i>BASE</i>	Advanced	Used when temperature sensor provides measured temperature value. Compensation is pure water with base based. Restricted to sensor cell constant 0.01.
User-defined (automatic)	<i>USR.DEF</i>	Advanced	Used when temperature sensor provides measured temperature value. Compensation is defined as ratio of uncompensated conductivity over compensated conductivity for specific set of temperatures.

1. Press the *SELECT* smart key to modify the *TC.TYPE* state.
2. Press the *NEXT* smart key to toggle between *MANUAL* and *AUTO*.
3. Press the *ENTER* smart key to accept the desired value. If manual was selected, press the *NEXT* smart key to go on to the next configuration parameter as shown in the advanced configuration sequence in Figure 8-4 and the basic configuration sequence in Figure 8-5. If *AUTO* was selected, go on with Step 4.
4. Press the *NEXT* smart key until the desired type of automatic temperature compensation appears.
5. If *TC.COEFF* or *USR.DEF* were selected, go to the next procedure in the sequence as shown in Figures 8-4 and 8-5. Otherwise, press the *ENTER* smart key to accept the desired value and go on to the next configuration parameter in the sequence.
6. To enter a new reference temperature for advanced programming:
 - a. Use the smart key to increment the blinking digit.
 - b. When the first digit is correct, use the smart key to move to the next digit.
 - c. Repeat Steps a and b for each digit.
 - d. Press the *ENTER* smart key to accept the value.

NOTE: To use the default value of 25°C, press the *ENTER* smart key without changing the digits.

PROCEDURE PR18 - TEMPERATURE COMPENSATION COEFFICIENT SETTING

PURPOSE/SCOPE

1 min.



This procedure describes how to configure the temperature compensation coefficient. This setting is available in both the basic and advanced programming modes.

Parts None.

Tools None.

PROCEDURE

The temperature compensation coefficient is used when a temperature sensor provides the measured temperature value. Compensation is based on percent change of conductivity at a reference temperature (e.g., 25-degrees Celsius) per degree Celsius. The value is adjustable between zero and 9.99 percent per degree Celsius. Refer to [Appendix A](#) for more information on temperature compensation.

1. Use the  smart key to increment the digit.
2. When the first digit is correct, use the  smart key to move to the next digit.
3. Repeat Steps 1 and 2 for each digit.
4. Press the *ENTER* smart key to accept the value.
5. Press the *NEXT* smart key to go on to the next configuration parameter.

PROCEDURE PR19 - USER-DEFINED TEMPERATURE COEFFICIENT PROGRAMMING

PURPOSE/SCOPE

10 min.

This procedure describes how to define the linear curve fit for a user-defined temperature compensation plot. This setting is available in the advanced programming mode.

Parts None.

Tools None.

PROCEDURE

The user-defined temperature compensation option requires uncompensated conductivity data from the reference temperature (e.g., 25-degrees Celsius) to the maximum process temperature on a representative sample of process solution. This data is used to calculate the ratio of uncompensated conductivity (K) to conductivity at the reference temperature (K_{STD}). These ratios are plotted against temperature.

An example of a typical user-defined temperature compensation plot is shown in Table PR19-1 and Figure PR19-1.

Table PR19-1. User-Defined Temperature Compensation Data

Point	Temp. (°C)	Uncompensated Conductivity (mS/cm)	Conductivity Ratio (K/ K_{STD})
1	0	7.21	0.70
2	25	10.30	1.00
3	50	12.25	1.19
4	75	12.97	1.26
5	100	12.82	1.24
6	200	9.06	0.88

The curve is a nonlinear function divided into five line segments. The endpoints represent points one and six. The breakpoints represent points two through five.

Refer to [Appendix A](#) for more information on temperature compensation.

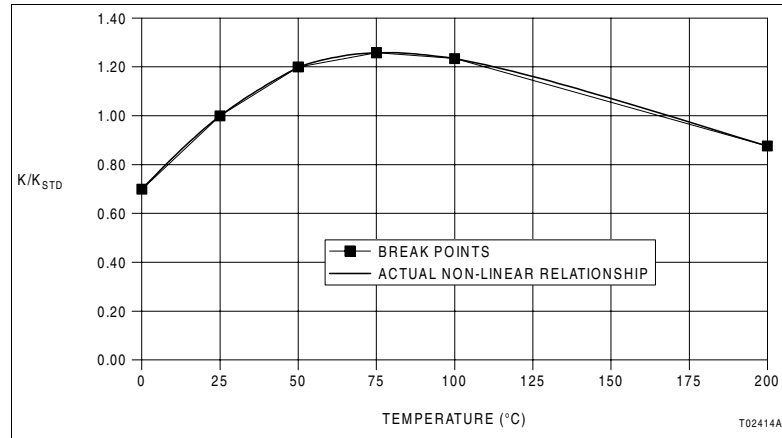

Figure PR19-1. User-Defined Temperature Compensation Curve

- 1. Obtain a plot of temperature versus conductivity ratio.
- 2. Divide the plot into five line segments that best approximate the shape of the curve. The start of the first and end of the fifth segments are the end points of the approximation.
- 3. Set the first endpoint temperature value ($TMP1^{\circ}C$).
 - a. Use the smart key to increment the value of the blinking digit.
 - b. When the first digit value is correct, use the smart key to move to the next digit.
 - c. Repeat Steps 3a and 3b for each digit.
 - d. Press the *ENTER* smart key to accept the new value.
- 4. Set the first endpoint ratio value ($K1/K25$) that represents the endpoint temperature value entered in Step 3.
 - a. Use the smart key to increment the value of the blinking digit.
 - b. When the first digit value is correct, use the smart key to move to the next digit.
 - c. Repeat Steps 4a and 4b for each digit.
 - d. Press the *ENTER* smart key to accept the new value.
- 5. Repeat Steps 3 and 4 to enter the four breakpoints and last endpoint ($TMP2^{\circ}C$ through $TMP6^{\circ}C$, and $K2/K25$ through $K6/K25$).
- 6. Press the *NEXT* smart key to go on to the next configuration parameter.

PROCEDURE PR20 - COMPLETING CONFIGURATION

PURPOSE/SCOPE

5 min.

This procedure describes how to complete the configuration. It includes configuring the output, damping, diagnostics, safe mode, and spike magnitude states. These settings, with the exception of the spike mode state, are available in both the basic and advanced programming modes. The spike mode state is available only in the advanced programming mode.

Parts None.

Tools None.

PROCEDURE



There are four (basic configurations) or five (advanced configurations) parameters to program to complete the configuration.

Output Range

The output state sets the output type and range. The default output range values are 10 percent of the full scale PV for each nominal cell constant as shown in Table PR20-1. If requiring a reverse acting output, reverse the four and 20-milliampere PV values.

Table PR20-1. Sensor Full Scale Measurement Ranges

Cell Constant	Full Scale PV
0.01	0 to 199.9 μ S/cm
0.10	0 to 1,999 μ S/cm
1.00	0 to 19.99 mS/cm

- 1. Press the *SELECT* smart key to modify the *OUTPUT* state.
- 2. The transmitter displays the process variable value for the 4-mA point.
 - a. Use the  smart key to increment the value of the blinking digit.
 - b. When the first digit value is correct, use the  smart key to move to the next digit.
 - c. Repeat Steps 2a and 2b for each digit.

- d. Press the *ENTER* smart key to accept the new value.
3. The transmitter displays the process variable value for the 20-mA point.
 - a. Use the smart key to increment the value of the blinking digit.
 - b. When the first digit value is correct, use the smart key to move to the next digit.
 - c. Repeat Steps 3a and 3b for each digit.
 - d. Press the *ENTER* smart key to accept the new value.
 4. Press the *NEXT* smart key to go on to the damping state.

Damping

The damping state applies a lag function on the output signal and reduces fluctuations caused by erratic process conditions. The damping value is adjustable from 00.0 to 99.9 seconds. This value represents the time required for the output to reach approximately 63.2 percent of its final value in response to a step change in the process variable input.

1. Press the *SELECT* smart key to modify the *DAMPNG* state.
2. The transmitter displays the current damping value.
 - a. Use the smart key to increment the value of the blinking digit.
 - b. When the first digit value is correct, use the smart key to move to the next digit.
 - c. Repeat Steps 2a and 2b for each digit.
 - d. Press the *ENTER* smart key to accept the new value.
3. Press the *NEXT* smart key to go on to the diagnostics state.

Diagnostics

The diagnostics state allows disabling of the built-in sensor diagnostics.

1. Press the *SELECT* smart key to modify the *DIAG* state.
2. Use the smart key to toggle between *ON* and *OFF*.
3. Press the *ENTER* smart key to accept the new value.

- 4. Press the *NEXT* smart key to go on to the safe mode state.

Safe Mode

The safe mode state determines the output level of the transmitter if an error condition occurs that renders the transmitter inoperable. The available states are *FAIL.LO* (fail low) and *FAIL.HI* (fail high). More information about error conditions is contained in [Section 12](#).

- 1. Press the *SELECT* smart key to modify the *SAF.MOD* state.
- 2. Use the *NEXT* smart key to toggle between *FAIL.HI* and *FAIL.LO*.
- 3. Press the *ENTER* smart key to accept the new value.
- 4. If this is an advanced configuration, go to Step 6. If this is a basic configuration press the *exit to MEASURE* smart key and go to Step 5.
- 5. When the *SAVE?* screen comes up, press the *YES* smart key to accept the configuration. Press the *NO* key to abort the configuration. In either case, the transmitter goes to the measure mode. Do not perform Step 6.
- 6. Press the *NEXT* smart key to go on to the spike state.

Spike Magnitude

The spike state sets the diagnostic spike level as a percent of output. This level determines the magnitude of the spike.

When the spike magnitude has been set to any level greater than zero percent and is enabled in the spike output state, the transmitter modulates the output signal by the configured level for one second out of every six seconds. Using this modulation, the transmitter informs the operator of a detected diagnostic condition.

Enter the spike magnitude as a percentage of the 16-milliamperere output range. A 10-percent spike magnitude generates a 1.6-milliamperere spike, a 20-percent spike magnitude generates a 3.2-milliamperere spike, etc.

NOTE: Once the spike state is *OFF*, changing the configured spike level in the configure mode will not enable the spike state. The spike state can only be turned *ON* or *OFF* in the output/hold mode.

- 1. Press the *SELECT* smart key to modify the *SPK.MAG* state.

- 2. The transmitter displays the current spike magnitude value.
 - a. Use the smart key to increment the value of the blinking digit.
 - b. When the first digit value is correct, use the smart key to move to the next digit.
 - c. Repeat Steps 2a and 2b for each digit.
 - d. Press the *ENTER* smart key to accept the new value.
- 3. Press the *exit to MEASURE* smart key.
- 4. When the *SAVE?* screen comes up, press the *YES* smart key to accept the configuration. Press the *NO* key to abort the configuration. In either case, the transmitter goes to the measure mode.

PROCEDURE PR21 - CONFIGURATION LOCKOUT

PURPOSE/SCOPE

5 min.

This procedure describes how to set the hardware configuration lockout jumper.

Parts None.

Tools

- Flat blade screwdriver.
- Needle nose pliers.

PROCEDURE

The transmitter has a lockout feature that, once engaged, prohibits access to the configure mode. This feature does not affect parameters that can be changed in the other modes of operation: calibrate, output/hold, security, and secondary display.

NOTE: Refer to EIA-625, *Requirements for Handling Electrostatic-Discharge-Sensitive (ESDS) Devices* before performing this procedure.

1. Turn off power to the transmitter and allow at least one minute for it to discharge.
2. Use the flat-blade screwdriver to loosen the four captive screws that secure the front bezel assembly to the transmitter shell.
3. Pull gently on the front bezel assembly to remove it from the shell.
4. The microprocessor PCB assembly, which is attached to the front bezel, contains the configuration lockout jumper. Position A (jumper W1 on pins 1 and 2) is the factory default position and disables the configuration lockout. Position B (jumper W1 on pins 2 and 3) enables the configuration lockout. Refer to Figure **PR21-1** and use the needle nose pliers to change the jumper to the desired position.
5. Place the front bezel assembly into the shell and press gently.
6. Use the bladed screwdriver to tighten the four captive screws.

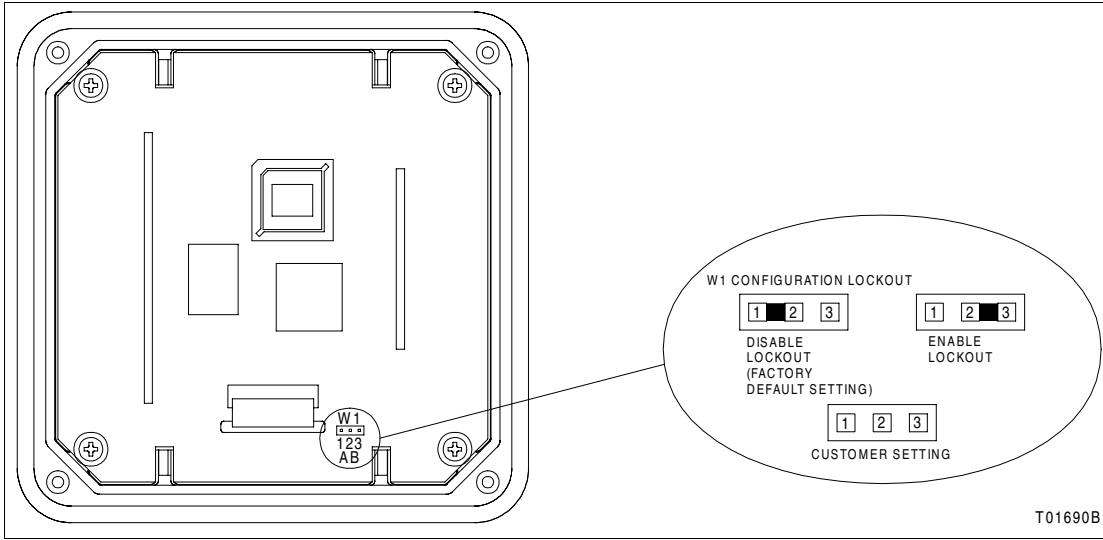

Figure PR21-1. Configuration Lockout Jumper

PROCEDURE PR22 - SECURITY AND PASSWORD ASSIGNMENT

PURPOSE/SCOPE

5 min.

This procedure describes how to define which modes and states of operation are security protected. It also describes how to set the password for the protected states and modes of operation, how to remove all security, and how to change security and the password.

Parts None.



Tools None.



PROCEDURE



This procedure contains three actions. Setting the security and password, removing all security, and changing the security and password.

NOTE: In the unlikely event that the password cannot be retrieved and the secured modes and states must be accessed, a reset security state exists. Refer to [PR23](#) for the reset security procedure.



Setting Security and Password



1. Press the *MENU* smart key until *SECURITY* is highlighted on the display.
2. Press the *SELECT* smart key to enter the security mode.
3. The *CALIBR* screen appears first. To set the security, press the  smart key to change the security from *OFF* to *ON* and continue with Step 4. To leave the security *OFF*, press the *ENTER* key and go on to Step 5.
4. Press the *ENTER* smart key to accept the selection.
5. The *OUTPUT* screen appears. To set the security, press the  smart key to change the security from *OFF* to *ON* and continue with Step 6. To leave the security *OFF*, press the *ENTER* key and go on to Step 7.
6. Press the *ENTER* smart key to accept the selection.
7. The *CONFIG* screen appears. To set the security, press the  smart key to change the security from *OFF* to *ON* and continue with Step 8. To leave the security *OFF*, press the *ENTER* key and go on to Step 9.
8. Press the *ENTER* smart key to accept the selection.

- 9. The *PASSWD* screen appears with *_ _ _* shown. Define the password for all secured modes and states.
 - a. Use the  smart key to increment the value of the blinking digit.
 - b. When the first digit value is correct, use the  smart key to move to the next digit.
 - c. Repeat Steps 9a and 9b for each digit.
 - d. Press the *ENTER* smart key to accept the password.





 - 10. The password must now be verified. The *PASSWD* screen appears with *_ _ _* shown.
 - a. Use the  smart key to increment the value of the blinking digit.
 - b. When the first digit value is correct, use the  smart key to move to the next digit.
 - c. Repeat Steps 10a and 10b for each digit.
 - d. Press the *ENTER* smart key to accept the password.
- NOTE:** The password must be defined as three digits and verified to enable security on the modes and states entered in Steps 3 through 8. If security is not *ON* for any of the modes and states, the transmitter bypasses the password screen.

Removing All Security





- 1. Press the *MENU* smart key until *SECURITY* is highlighted on the display.
- 2. Press the *SELECT* smart key to enter the security mode.
- 3. If the security mode has been secured, the transmitter requires the password and displays *_ _ _*. To enter the password:
 - a. Use the  smart key to increment the value of the blinking digit.
 - b. When the first digit value is correct, use the  smart key to move to the next digit.
 - c. Repeat Steps 3a and 3b for each digit.
 - d. When the password is correct, press the *ENTER* smart key.

- 4. The *CALIBR* screen appears first. Press the  smart key to change the security from *ON* to *OFF*.
- 5. Press the *ENTER* smart key to accept the selection.
- 6. The *OUTPUT* screen appears. Press the  smart key to change the security from *ON* to *OFF*.
- 7. Press the *ENTER* smart key to accept the selection.
- 8. The *CONFIG* screen appears. Press the  smart key to change the security from *ON* to *OFF*.
- 9. Press the *ENTER* smart key to accept the selection.

Changing Security or Password

- 1. Press the *MENU* smart key until *SECURITY* is highlighted on the display.
- 2. Press the *SELECT* smart key to enter the security mode.
- 3. If the security mode has been secured, the transmitter requires the password and displays _ _ . To enter the password:
 - a. Use the  smart key to increment the value of the blinking digit.
 - b. When the first digit value is correct, use the  smart key to move to the next digit.
 - c. Repeat Steps 3a and 3b for each digit.
 - d. When the password is correct, press the *ENTER* smart key.
- 4. The *CALIBR* screen appears first. To change the security, press the  smart key to toggle the security between *OFF* and *ON* and continue with Step 5. To leave the security unchanged, press the *ENTER* key and go on to Step 6.
- 5. Press the *ENTER* smart key to accept the selection.
- 6. The *OUTPUT* screen appears. To change the security, press the  smart key to toggle the security between *OFF* and *ON* and continue with Step 7. To leave the security unchanged, press the *ENTER* key and go on to Step 8.
- 7. Press the *ENTER* smart key to accept the selection.
- 8. The *CONFIG* screen appears. To change the security, press the  smart key to toggle the security between *OFF* and *ON*

and continue with Step 9. To leave the security unchanged, press the ENTER key and go on to Step 10.

- 9. Press the *ENTER* smart key to accept the selection.
- 10. The *PASSWD* screen appears with _ _ _ shown. Either change the password or enter the existing password to accept the changes to the security.
 - a. Use the  smart key to increment the value of the blinking digit.
 - b. When the first digit value is correct, use the  smart key to move to the next digit.
 - c. Repeat Steps 10a and 10b for each digit.
 - d. Press the *ENTER* smart key to accept the password.
- 11. If the password was changed, it must now be verified. If the password was not changed, this procedure is complete. The *PASSWD* screen appears with _ _ _ shown.
 - a. Use the  smart key to increment the value of the blinking digit.
 - b. When the first digit value is correct, use the  smart key to move to the next digit.
 - c. Repeat Steps 11a and 11b for each digit.
 - d. Press the *ENTER* smart key to accept the password.

PROCEDURE PR23 - UTILITY MODE

PURPOSE/SCOPE

5 min.

This procedure describes how to use the utility mode.

Parts None.

Tools None.

PROCEDURE

The utility mode provides access to powerful functions not usually needed during normal operating conditions.

Advanced/Basic Programming

The basic programming mode contains a subset of configuration options found in the advanced programming mode. Separation into two programming groups is advantageous when limited functionality is desired. Fewer options reduce confusion and the possibility of configuration errors.

Transmitters ordered with the advanced programming option can be changed between basic and advanced programming. Transmitters ordered with the basic programming option require an upgrade password to change to advanced programming. Contact ABB Instrumentation to obtain the password.

The programming toggle for transmitters with the advanced programming option must be set in two locations: user state in the utility mode and modify configure state in the configure mode. In order to select either the basic or advanced programming mode in the modify configure state, the programming mode must be set to advanced in the user state.

- 1. Press the hidden key located at the center top of the front panel. The prompt *USER* appears in the secondary display.
- 2. Press the *SELECT* smart key. The text *MODE* appears in the secondary display.
- 3. Press the *SELECT* smart key and the *BASIC* screen appears. Press the *ENTER* smart key to set the programming to basic, and move to the next user state or press the *NEXT* smart key to move to the next screen and go on to Step 4.
- 4. The *ADVNC*D screen appears. Press the *ENTER* smart key to set the programming to advanced and move to the next user state.

Configuration Reset



The reset configuration user state returns the configuration of the transmitter back to factory default settings. Table PR23-1 summarizes the default software settings.

Table PR23-1. Default Configuration

Parameter	Setting
Instrument mode	Basic
Analyzer type	Conductivity, cell constant = 0.01
Temperature sensor type	Pt 1000
Temperature compensation type	Manual
Output range	0.00 to 199.9 $\mu\text{S}/\text{cm}$
Damping value	00.5 sec
Sensor diagnostics	Disable
Safe mode failed output state	Low
Spike output ¹	0%
Hardware configuration lockout ²	Jumper position 1-2 - disable

NOTES:

1. Feature only available in advanced programming.
2. Refer to PR21 for procedure to change jumper position.

1. Press the hidden key located at the center top of the front panel. The prompt *USER* appears in the secondary display.
2. Press the *SELECT* smart key. The text *MODE* appears in the secondary display.
3. Press the *NEXT* smart key until *RST.CON* appears in the secondary display.
4. Press the *SELECT* smart key to reset the configuration.
5. If the configure mode is secured, the transmitter requires the password and displays *_ _ _*. To enter the password:
 - a. Use the  smart key to increment the value of the blinking digit.
 - b. When the first digit value is correct, use the  smart key to move to the next digit.
 - c. Repeat Steps 5a and 5b for each digit.
 - d. Press the *ENTER* smart key.
6. The text *RESET?* appears. Press the *YES* smart key to confirm the reset or the *NO* smart key to abort the procedure.

Security Reset

The reset security state returns the security of the transmitter back to factory default settings. The factory defaults are security off for all applicable modes and the modify configure state.

- 1. Press the hidden key located at the center top of the front panel. The prompt *USER* appears in the secondary display.
- 2. Press the *SELECT* smart key. The text *MODE* appears in the secondary display.
- 3. Press the *NEXT* smart key until *RST.SEC* appears in the secondary display.
- 4. Press the *SELECT* smart key to reset the security.
- 5. The transmitter displays *_ _ _*. The security reset password is 732. To enter the password:
 - a. Use the smart key to increment the value of the blinking digit.
 - b. When the first digit value reaches 7, use the smart key to move to the next digit.
 - c. Use the smart key to increment the value of the blinking digit.
 - d. When the second digit value reaches 3, use the smart key to move to the next digit.
 - e. Use the smart key to increment the value of the blinking digit.
 - f. When the third digit value reaches 2, press the *ENTER* smart key.
- 6. The text *RESET?* appears. Press the *YES* smart key to confirm the operation or the *NO* smart key to abort the procedure.

Reset All Parameters

The reset all user state returns all transmitter values back to factory defaults. This includes calibration, output/hold, configuration, security, and secondary display values.

- 1. Press the hidden key located at the center top of the front panel. The prompt *USER* appears in the secondary display.
- 2. Press the *SELECT* smart key. The text *MODE* appears in the secondary display.

- 3. Press the *NEXT* smart key until *RST.ALL* appears in the secondary display.
- 4. Press the *SELECT* smart key to reset all transmitter parameters.
- 5. The transmitter displays _ _ . The reset all password is 255. To enter the password:
 - a. Use the smart key to increment the value of the blinking digit.
 - b. When the first digit value reaches 2, use the smart key to move to the next digit.
 - c. Use the smart key to increment the value of the blinking digit.
 - d. When the second digit value reaches 5, use the smart key to move to the next digit.
 - e. Use the smart key to increment the value of the blinking digit.
 - f. When the third digit value reaches 5, press the *ENTER* smart key.
- 6. The text *RESET?* appears. Press the *YES* smart key to confirm the reset or the *NO* smart key to abort the procedure.

Software Reset

The software reset user state causes the software to go through a boot sequence. All programmable transmitter parameters remain unchanged after performing the software reset.

- 1. Press the hidden key located at the center top of the front panel. The prompt *USER* appears in the secondary display.
- 2. Press the *SELECT* smart key. The text *MODE* appears in the secondary display.
- 3. Press the *NEXT* smart key until *RST.SFT* appears in the secondary display.
- 4. Press the *SELECT* smart key to initiate the software reset.
- 5. The text *RESET?* appears. Press the *YES* smart key to confirm the reset or the *NO* smart key to abort the procedure.

PROCEDURE PR24 - SENSOR INSPECTION

PURPOSE/SCOPE

10 min.

This procedure describes how to visually inspect the sensor.

Parts None.

Tools None.

PROCEDURE

If the sensor is suspected of being the source of problems, a quick visual inspection can identify the problem.

Sensor Body

- 1. Remove the sensor from the process.
- 2. Inspect the sensor body for cracks and distortions.
- 3. If cracks or distortions exist, contact ABB Instrumentation for alternative sensor styles and materials.

Cable and Connectors

- 1. Inspect the sensor cable for cracks, cuts, or shorts.
- 2. If using a junction box or extension cable, check for moisture, oil, corrosion, or particulates. All connections must be dry and free of oil, corrosion, and particulates. Even slight amounts of these contaminants can short sensor signals and affect conductivity readings.
- 3. Check to see that all wiring is dry and not shorting against any metal, conduit, or earth grounds.

O-Ring Seals

- 1. Inspect the sealing O-rings for attack by the process liquid.
- 2. If the O-rings show evidence of corrosion, deterioration, or distortion, contact ABB Instrumentation for alternate material choices.

PROCEDURE PR25 - ELECTRONIC SENSOR TEST

PURPOSE/SCOPE

10 min.

This procedure describes how to run the electronic sensor test.

Parts None.

Tools

- Digital multimeter (DMM) with a conductance function capable of reading zero to 200 nanosiemens, and a resistance function capable of reading zero to 20 kilohms.
- Temperature measuring device.

PROCEDURE

To verify the integrity of conductivity sensor elements and associated cable:

- 1. Disconnect the sensor leads and automatic temperature compensator leads from the transmitter.
- 2. Use the DMM set to measure ohms to measure the resistance between the yellow and blue temperature compensator leads.

a. If using a three-k Ω Balco RTD, the expected resistance can be calculated from:

$$R_{TC} = ((T - 25^{\circ} C) \times 0.0045) + 1 \times 3,000$$

where T is the temperature in degrees Celsius. The measured resistance should be within the expected value by $\pm 15\%$.

b. If using a Pt 100 RTD, the expected resistance can be calculated from:

$$R_{TC} = 100 + ((T - 0^{\circ} C) \times 0.385)$$

where T is the temperature in degrees Celsius. The measured resistance should be within the expected value by $\pm 5\%$.

c. If using a Pt 1000 RTD, the expected resistance can be calculated from:

$$R_{TC} = 1000 + ((T - 0^{\circ} C) \times 3.85)$$

where T is the temperature in degrees Celsius. The measured resistance should be within the expected value by $\pm 5\%$.

- 3. Moisture intrusion behind the sensor electrode seal can be detected. Remove the sensor from the process and dry it thoroughly.
- 4. Use the DMM set to measure conductance, to measure the conductance between the yellow temperature compensator lead and each of the other sensor leads (green, black, and heavy green). The reading must be less than 0.05 nS.
- 5. Check the conductance between the green drive lead and each of the other sensor leads (black and heavy green). The reading must be less than 0.05 nS.
- 6. Check the conductance between the heavy green shield lead and each of the other sensor leads (blue, yellow, black, and green). The reading must be less than 0.05 nS.

PROCEDURE PR26 - TRANSMITTER TROUBLESHOOTING WITHOUT SENSOR

PURPOSE/SCOPE

10 min.

This procedure describes how to troubleshoot the transmitter with the sensor disconnected. Sensor simulation is an easy way to check the operation of the transmitter.

Parts None.

Tools

- Decade resistance box.
- 100- Ω , 1,000- Ω , or 3,000- Ω resistor based on temperature sensor configuration.

PROCEDURE

1. Remove the transmitter from the process and disconnect the sensor.

NOTE: The transmitter calibration values must be set back to those entered at the factory in order for this procedure to be valid.

2. There are two ways to perform sensor simulation. Either connect the appropriate resistor, based on temperature sensor configuration, across the temperature sensor input as shown in Figure PR26-1, or configure the transmitter for manual temperature compensation with a constant 25°C temperature.
3. Connect the transmitter in the setup shown in Figure PR26-1.

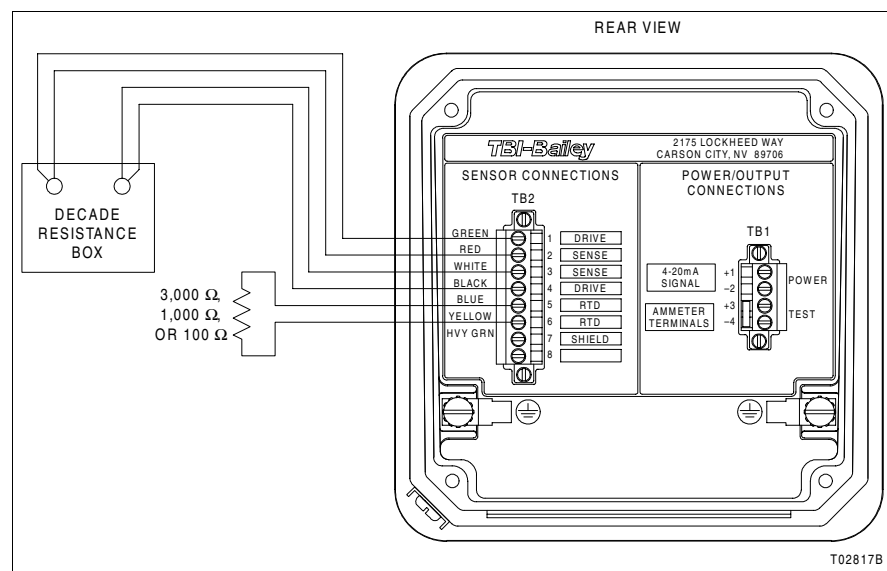

Figure PR26-1. Sensor Simulation Setup

- 4. Set the decade resistance box to the values indicated in Table PR26-1 and record the displayed value, comparing it to the value indicated in the desired display value column.

NOTE: The reset calibration feature resets all calibration values. Before putting the transmitter back into service, be sure to perform a temperature, process, and output calibration.

Table PR26-1. Sensor Simulation Values

Cell Constant	Variable Resistance (Ω)	Desired Display Value	Displayed Value
1.00	Open	0.01 μ S/cm	
	5,000.0	200 μ S/cm	
	1,000.0	1,000 μ S/cm	
	500.0	2.00 mS/cm	
	100.0	10.00 mS/cm	
	50.0	19.99 mS/cm (over range)	
0.10	Open	0.00 μ S/cm	
	50,000	2.00 μ S/cm	
	5,000	20.0 μ S/cm	
	1,000	100.0 μ S/cm	
	500	200 μ S/cm	
	100	1,000 μ S/cm	
	50	1,999 μ S/cm (over range)	
0.01	Open	0.000 μ S/cm	
	100,000	0.100 μ S/cm	
	50,000	0.200 μ S/cm	
	5,000	2.00 μ S/cm	
	1,000	10.00 μ S/cm	
	500	20.0 μ S/cm	
	100	100.0 μ S/cm	
	50	199.9 μ S/cm (over range)	

PROCEDURE PR27 - SENSOR CLEANING

PURPOSE/SCOPE

20 min.

This procedure describes how to clean the sensor.

Parts None.

Tools

- Gloves.
- Eye protection.
- Safety shield.
- Other protective items as applicable.
- 1% to 5% hydrochloric acid (HCl) solution (for acid dip).
- Isopropyl alcohol or other appropriate solvent (for solvent dip).
- Clean cloth.
- Rag, acid brush, or toothbrush (for physical cleaning).
- Water.

SAFETY CONSIDERATIONS

WARNING

1. Consider the material compatibility between cleaning fluids and process liquids. Incompatible fluids can react with each other causing injury to personnel and equipment damage.

2. Acids and bases can cause severe burns. Use hand and eye protection when handling.



3. Use solvents only in well ventilated areas. Avoid prolonged or repeated breathing of vapors or contact with skin. Solvents can cause nausea, dizziness, and skin irritation. In some cases, overexposure to solvents has caused nerve and brain damage. Solvents are flammable - do not use near extreme heat or open flame.

PROCEDURE

ABB Instrumentation conductivity sensors are cleaned using one or a combination of methods. These are recommendations and may not be suitable for all applications. Other cleaning methods may be developed that better suit particular applications. When cleaning, observe all safety precautions required for handling chemicals. When handling chemicals, always use gloves, eye protection, safety shields, and similar protective items, and consult material data safety sheets.



Acid Dip

This method removes scales caused by hard water.

-  1. Verify that any process fluid on the sensor is compatible with HCl.
-  2. Put on gloves, eye protection, safety shields, and other protective items as needed.
- 3. Dip the tip of the sensor into a one-percent to five-percent solution of HCl until this region is free of the unwanted coating. Minimize exposure of any of the metal on the sensor to this solution or corrosion may occur.
- 4. Rinse the sensor with clean water.

Solvent Dip

This method removes organic coatings.

-  1. Verify that any process fluid on the sensor is compatible with isopropyl alcohol or other appropriate solvent.
-  2. Put on gloves, eye protection, safety shields, and other protective items as needed.
- 3. Dip the sensor into the solvent. Do not use a solvent that is known to be incompatible with the sensor.
- 4. Remove the solvent using a clean cloth.

Physical Cleaning

This method removes especially thick scales and accumulations.

- 1. Use a rag, acid brush, or toothbrush to clean the sensor.

PROCEDURE PR28 - KEYPAD CLEANING

PURPOSE/SCOPE

2 min.

This procedure describes how to clean the keypad.

Parts None.

Tools

- Soft, lint-free cloth.
- Mild soap.
- Warm water.

PROCEDURE

1. Mix mild soap into warm water according to the soap manufacturer's instructions.
2. Dampen the cloth with the soap and water mixture and wring out excess liquid.
3. Gently wash off the keypad with the cloth.
4. Allow to air dry.

PROCEDURE PR29 - FRONT BEZEL REMOVAL

PURPOSE/SCOPE

2 min.

This procedure describes how to remove the front bezel.

Parts None.

Tools • Flat-blade screwdriver.

PROCEDURE

NOTE: Refer to EIA-625, *Requirements for Handling Electrostatic-Discharge-Sensitive (ESDS) Devices* before performing this procedure.

- 1. Remove power from the transmitter and allow at least one minute for it to discharge.
- 2. Use the flat-blade screwdriver to loosen the four captive screws that secure the front bezel to the transmitter shell.
- 3. Pull gently on the front bezel to remove it from the shell.

PROCEDURE PR30 - POWER SUPPLY PCB REMOVAL

PURPOSE/SCOPE

2 min.

This procedure describes how to remove the power supply PCB.

Parts None.

Tools • Phillips screwdriver.

PROCEDURE

NOTE: Refer to EIA-625, *Requirements for Handling Electrostatic-Discharge-Sensitive (ESDS) Devices* before performing this procedure.

1. Use the Phillips screwdriver to remove the two screws that retain the power supply PCB (Fig. PR30-1).
2. Gently pull on the power supply PCB to disengage it from the microprocessor PCB.

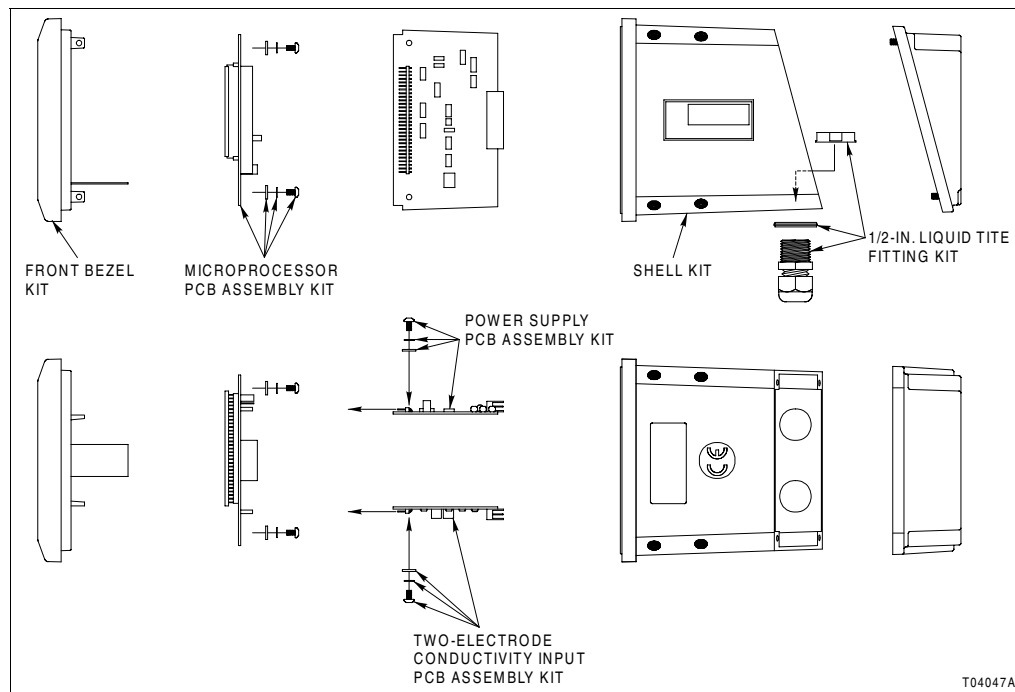

Figure PR30-1. Power Supply PCB Removal

PROCEDURE PR31 - TWO-ELECTRODE CONDUCTIVITY INPUT PCB REMOVAL

PURPOSE/SCOPE

2 min.

This procedure describes how to remove the two-electrode conductivity input PCB.

Parts None.

Tools • Phillips screwdriver.

PROCEDURE

NOTE: Refer to EIA-625, *Requirements for Handling Electrostatic-Discharge-Sensitive (ESDS) Devices* before performing this procedure.

1. Use the Phillips screwdriver to remove the two screws that retain the two-electrode conductivity input PCB (Fig. PR31-1).
2. Gently pull on the two-electrode conductivity input PCB to disengage it from the microprocessor PCB.

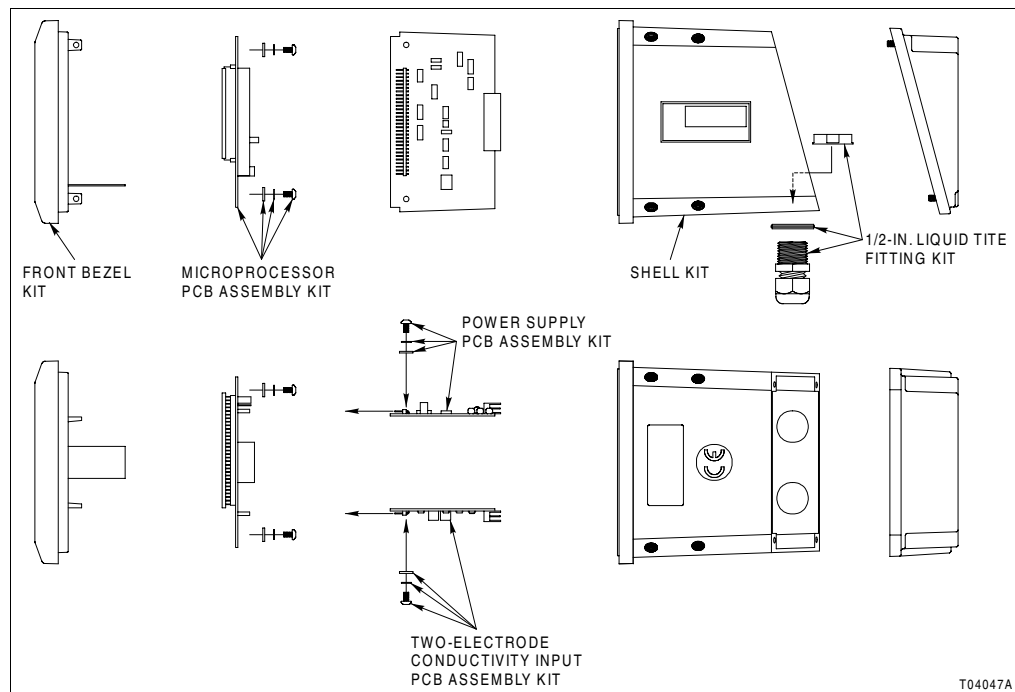

Figure PR31-1. Conductivity Input PCB Removal

PROCEDURE PR32 - MICROPROCESSOR PCB REPLACEMENT

PURPOSE/SCOPE

2 min.

This procedure describes how to replace the microprocessor PCB.

Parts

Number	Qty	Description
4TB9515-0178	1	Microprocessor PCB

Tools

- Phillips screwdriver.

PROCEDURE

NOTE: Refer to EIA-625, *Requirements for Handling Electrostatic-Discharge-Sensitive (ESDS) Devices* before performing this procedure.

1. Release the keypad ribbon cable connector latch by pushing the outside of the connector and lightly pulling outwards.
2. Use the Phillips screwdriver to remove the two screws that secure the microprocessor PCB to the front bezel (Fig. PR32-1).
3. Remove the microprocessor PCB.

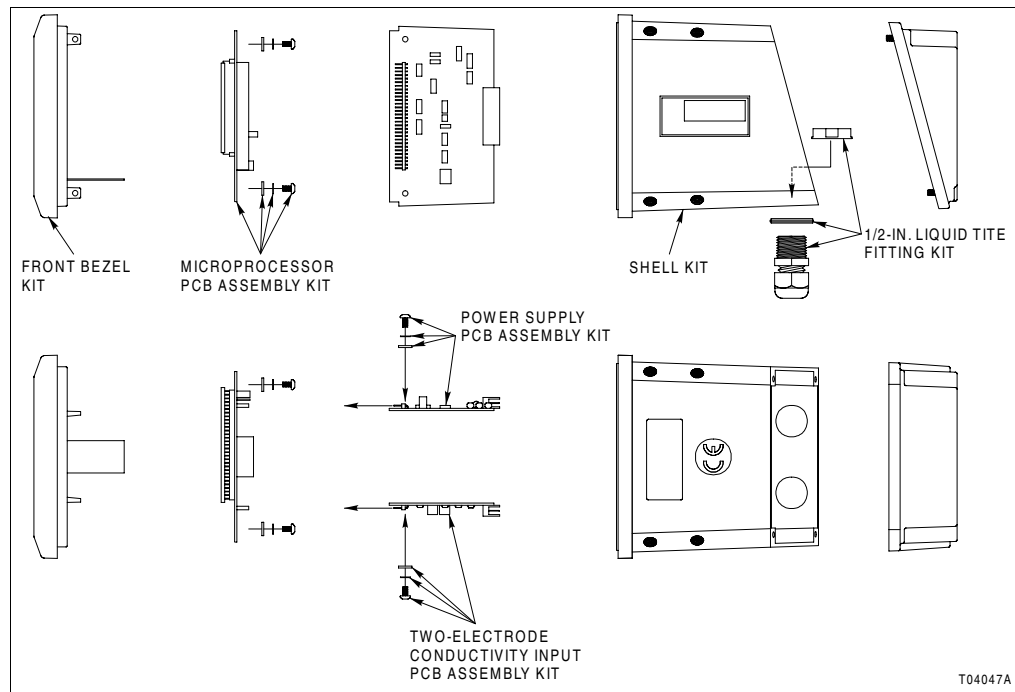

Figure PR32-1. Microprocessor PCB Replacement

- 4. Install the new microprocessor PCB.
- 5. Install the two screws to secure the microprocessor PCB to the front bezel and tighten them with the Phillips screwdriver.
- 6. Insert the keypad ribbon cable into the mating connector and push connector locks into place.

PROCEDURE PR33 - TWO-ELECTRODE CONDUCTIVITY INPUT PCB INSTALLATION

PURPOSE/SCOPE

2 min.

This procedure describes how to install the two-electrode conductivity input PCB.

Parts

Number	Qty	Description
4TB9515-0187	1	2-electrode conductivity input PCB

Tools

- Phillips screwdriver.

PROCEDURE

NOTE: Refer to EIA-625, *Requirements for Handling Electrostatic-Discharge-Sensitive (ESDS) Devices* before performing this procedure.

1. Insert the header on the two-electrode conductivity input PCB into the proper connector on the microprocessor PCB.
2. Install the two screws to retain the two-electrode conductivity input PCB and tighten them with the Phillips screwdriver.

PROCEDURE PR34 - POWER SUPPLY PCB INSTALLATION

PURPOSE/SCOPE

2 min.

This procedure describes how to install the power supply PCB.

Parts

Number	Qty	Description
4TB9515-0155	1	Power supply PCB
4TB9515-0157		Power supply PCB for HART compatible transmitters
4TB9515-0158		Power supply PCB with lightning arrestor
4TB9515-0159		Power supply PCB with lightning arrestor for HART compatible transmitters

Tools

- Phillips screwdriver.

PROCEDURE

NOTE: Refer to EIA-625, *Requirements for Handling Electrostatic-Discharge-Sensitive (ESDS) Devices* before performing this procedure.

- 1. Insert the header on the power supply PCB into the proper connector on the microprocessor PCB.
- 2. Install the two screws to retain the power supply PCB and tighten them with the Phillips screwdriver.

PROCEDURE PR35 - FRONT BEZEL INSTALLATION

PURPOSE/SCOPE

2 min.

This procedure describes how to install the front bezel.

Parts

Number	Qty	Description
4TB9515-0160	1	Front bezel

Tools

- Flat-blade screwdriver.

PROCEDURE

NOTE: Refer to EIA-625, *Requirements for Handling Electrostatic-Discharge-Sensitive (ESDS) Devices* before performing this procedure.

1. Insert the front bezel with electronics assembly into the shell and press gently to engage terminal block connectors.
2. Use the flat-blade screwdriver to tighten the four captive screws.

PROCEDURE PR36 - REAR COVER REPLACEMENT

PURPOSE/SCOPE

2 min.

This procedure describes how to replace the rear cover.

Parts

Number	Qty	Description
4TB9515-0162	1	Rear cover

Tools

- Flat-blade screwdriver.

PROCEDURE

NOTE: Refer to EIA-625, *Requirements for Handling Electrostatic-Discharge-Sensitive (ESDS) Devices* before performing this procedure.

1. Remove power from the transmitter and allow at least one minute for it to discharge.
2. Use the flat-blade screwdriver to loosen the four captive screws that secure the rear cover to the transmitter shell.
3. Pull gently on the rear cover to remove it from the shell.
4. Install the rear cover onto the shell.
5. Use the flat-blade screwdriver to tighten the four captive screws.

PROCEDURE PR37 - SHELL REPLACEMENT

PURPOSE/SCOPE

1 min.

This procedure is for part number reference only. The repair sequence flowchart (Fig. 14-1) includes the procedures necessary to replace the transmitter shell.

Parts

Number	Qty	Description
4TB9515-0175	1	Shell

Tools

None.

A

Accessories	1-9
Accuracy	1-6
Advanced configuration	
Analyzer type	PR15-1
Concentration programming	PR16-1
Damping	PR20-2
Decimal point location	PR16-1
Diagnostics	PR20-2
Engineering units	PR16-1
Linear curve fit	PR16-2
Modifying while viewing	PR13-1
Output range	PR20-1
Programming mode change	PR14-1
Safe mode	PR20-3
Sensor cell constant	PR15-1
Spike magnitude	PR20-3
Temperature compensation coefficient	PR18-1
Temperature sensor type	PR17-1
Text string	PR16-1
User-defined temperature compensation	PR19-1
Viewing	PR12-1
Ambient temperature effect	1-7
Analyzer type	PR15-1

B

Basic configuration	
Analyzer type	PR15-1
Damping	PR20-2
Diagnostics	PR20-2
Modifying while viewing	PR13-1
Output range	PR20-1
Programming mode change	PR14-1
Safe mode	PR20-3
Sensor cell constant	PR15-1
Temperature compensation coefficient	PR18-1
Temperature sensor type	PR17-1
Viewing	PR12-1
Basic/advanced configuration	PR23-1
Boredom switch	5-1

C

Calibration	
Conductivity/concentration	6-1, PR7-1
Diagnostics	12-6
Edit	6-1, PR9-1
Output	6-1, PR8-1
Reset	6-1, PR10-1
Sequence	6-1
States	6-1

Temperature	6-1, PR6-1
Cell constant	PR15-1
Changing password	PR22-3
Changing security	PR22-3
Cleaning	
Keypad	PR28-1
Sensor	PR27-1
Concentration	
Calibration	PR7-1
Programming	B-1
Decimal point location	PR16-1
Engineering units	PR16-1
Linear curve fit	PR16-2
Text string	PR16-1
Conductivity	
Calibration	PR7-1
Conductivity input PCB installation	PR33-1
Conductivity input PCB removal	PR31-1
Conductivity/concentration calibration	6-1
Conductivity-to-concentration conversion	PR16-2
Configuration	
Advanced	
Analyzer type	PR15-1
Concentration programming	PR16-1
Damping	PR20-2
Decimal point location	PR16-1
Diagnostics	PR20-2
Engineering units	PR16-1
Linear curve fit	PR16-2
Modifying while viewing	PR13-1
Output range	PR20-1
Programming mode change	PR14-1
Safe mode	PR20-3
Sensor cell constant	PR15-1
Spike magnitude	PR20-3
Temperature compensation coefficient	PR18-1
Temperature sensor type	PR17-1
Text string	PR16-1
User-defined temperature compensation	PR19-1
Viewing	PR12-1
Basic	
Analyzer type	PR15-1
Damping	PR20-2
Diagnostics	PR20-2
Modifying while viewing	PR13-1
Output range	PR20-1
Programming mode change	PR14-1
Safe mode	PR20-3
Sensor cell constant	PR15-1
Temperature compensation coefficient	PR18-1
Temperature sensor type	PR17-1
Viewing	PR12-1

Index (continued)

Concentration programming.....	PR16-1	Damping	PR11-3
Defaults	8-1	Release.....	PR11-2
Lockout.....	PR21-1	How to use this instruction.....	1-4
Modifying.....	PR12-1		
Reset.....	PR23-2	I	
Sequence	8-2	Input types	1-6
Viewing.....	PR12-1	Inspection	3-1
		Installation	
D		Configuration lockout.....	PR21-1
Damping.....	1-7, 2-2, PR11-3, PR20-2	Mounting	
Decimal point location.....	PR16-1	Hinge.....	PR4-1
Default configuration	8-1	Panel.....	PR2-1
Diagnostics.....	2-2, PR20-2	Pipe.....	PR1-1
Calibration	12-6	Rotation.....	3-3
Fault codes.....	12-1	Wall	PR3-1
Error codes.....	12-5, 12-6	Sequence.....	3-3
Problem codes, common.....	12-2	Wiring	
Problem codes, uncommon.....	12-3	Sensor.....	PR5-3
Spike	PR11-4	Signal and power	PR5-1
Display resolution.....	1-6	Instruction content	1-3
Dynamic response	1-7	Intended user.....	1-1
E		K	
Edit calibration.....	6-1, PR9-1	Keypad cleaning	PR28-1
Electronic sensor test.....	PR25-1		
Engineering units	PR16-1	L	
Entering password	9-1	LCD	4-1
Environmental	1-8	Linear curve fit.....	PR16-2
Error codes.....	12-5, 12-6	Load limits	1-9
		Load resistance range	1-7
F		Location considerations.....	3-1
Fault codes	12-1	Hazardous locations	3-2
Error codes.....	12-5, 12-6	Radio frequency interference (RFI)	3-2
Problem codes	12-1		
Common	12-2	M	
Uncommon	12-3	Maintenance	13-1
Fault icon	4-4	Keypad cleaning	PR28-1
Fault info	5-1	Schedule.....	13-2
Features.....	1-2	Sensor cleaning	PR27-1
Front bezel installation	PR35-1	Sensor inspection	PR24-1
Front bezel removal	PR29-1	Measure mode.....	5-1
Function flow tree.....	C-4	Boredom switch	5-1
		Fault info	5-1
H		Menu smart key	5-2
Hardware lockout.....	PR21-1	Primary display	5-1
Hazardous locations.....	3-2	Secondary display	5-1
Hinge mounting.....	PR4-1	Menu smart key	5-2
Hold icon	4-4	Microprocessor PCB replacement.....	PR32-1
Hold output.....	PR11-1	Modes of operation.....	4-3

Modify configuration PR12-1
 Mounting
 Hinge PR4-1
 Panel..... PR2-1
 Pipe..... PR1-1
 Wall..... PR3-1
 Mounting kits 1-9

N

Nomenclature 1-5
 Nonlinearity 1-7

O

Operating modes 4-3
 Operator interface 4-1
 LCD..... 4-1
 Smart keys..... 4-2
 Other equipment interface 3-3
 Output calibration 6-1, PR8-1
 Output maximum span 1-7
 Output minimum span 1-7
 Output range PR11-2, PR20-1
 Output/hold 7-1, PR11-1
 Damping PR11-3
 Hold output PR11-1

P

Panel mounting PR2-1
 Password
 Changing PR22-3
 Entering 9-1
 Setting..... PR22-1
 Pipe mounting PR1-1
 Power supply effect 1-8
 Power supply PCB installation..... PR34-1
 Power supply PCB removal..... PR30-1
 Power wiring PR5-1
 Primary display 5-1
 Problem codes 12-1
 Common 12-2
 Uncommon 12-3
 Process display range 1-6
 Programming mode change PR14-1

R

Radio frequency interference 3-2
 Rear cover replacement PR36-1
 Reference documents 1-4
 Release hold output PR11-2

Removing security PR22-2
 Repair
 Conductivity input PCB PR31-1, PR33-1
 Front bezel PR29-1, PR35-1
 Microprocessor PCB PR32-1
 Power supply PCB PR30-1, PR34-1
 Rear cover..... PR36-1
 Sequence 14-1
 Shell PR37-1
 Repeatability 1-7
 Replacement parts 15-1
 Rerange PR11-2
 Reset all parameters PR23-3
 Reset calibration 6-1, PR10-1
 Reset configuration PR23-2
 Reset security PR23-3
 Return materials procedures..... 15-1
 RFI 3-2
 Rotation..... 3-3

S

Safe mode..... PR20-3
 Secondary display 5-1, 10-1
 Use 10-1
 Security 9-1
 Changing..... PR22-3
 Procedure..... PR22-1
 Removing PR22-2
 Reset..... PR23-3
 Screen flow 9-2
 Sequence 9-1
 Setting PR22-1
 Sensor
 Cable length 1-8
 Cell constant PR15-1
 Cleaning PR27-1
 Electronic test..... PR25-1
 Full scale measurement range 1-6
 Inspection PR24-1
 Types 1-9
 Wiring PR5-3
 Setting password PR22-1
 Setting security PR22-1
 Shell replacement PR37-1
 Signal wiring..... PR5-1
 Size 1-8
 Smart keys 4-2
 Software reset..... PR23-4
 Specifications 1-6
 Accuracy 1-6
 Ambient temperature effect..... 1-7

Index (continued)

Damping	1-7	Display range	1-6
Display resolution	1-6	Effect	1-7
Dynamic response	1-7	Sensor	
Environmental	1-8	Type	PR17-1
Input types	1-6	Text prompts	C-1
Load limits	1-9	Text string	PR16-1
Load resistance range	1-7	Transmitter troubleshooting	PR26-1
Nonlinearity	1-7	Troubleshooting	
Output maximum span	1-7	Electronic sensor test	PR25-1
Output minimum span	1-7	Sequence	12-7
Power supply effect	1-8	Transmitter (without sensor)	PR26-1
Process display range	1-6	Turn on time	1-8
Repeatability	1-7		
Sensor cable length	1-8	U	
Sensor full scale measurement range	1-6	Unpacking	3-1
Size	1-8	User state	11-1
Stability	1-7	User-defined temperature compensation	PR19-1
Supply voltage	1-7	Utility mode	11-1, PR23-1
Temperature compensation	1-7	Basic/advanced	PR23-1
Temperature display range	1-6	Reset all parameters	PR23-3
Turn on time	1-8	Reset configuration	PR23-2
Type	1-6	Reset security	PR23-3
Weight	1-8	Software reset	PR23-4
Spike	PR11-4	User state	11-1
Spike magnitude	PR20-3		
Spike output	2-3, 4-4	V	
Stability	1-7	Viewing configuration	PR12-1
Supply voltage	1-7	Modifying while	PR13-1
Support services	15-1		
Replacement parts	15-1	W	
Return materials procedures	15-1	Wall mounting	PR3-1
		Weight	1-8
T		Wiring	
Temperature		Considerations	3-3
Calibration	6-1, PR6-1	Sensor	PR5-3
Compensation	1-7, 2-1, A-1	Signal and power	PR5-1
Coefficient	PR18-1		
User-defined	PR19-1		

Visit ABB on the World Wide Web at <http://www.abb.com>

Our worldwide staff of professionals is ready to meet *your* needs for process automation.
For the location nearest you, please contact the appropriate regional office.

Form WTPEEU1520002A0 Litho in U.S.A. 1199
Copyright © 1998 by ABB Automation Inc., As An Unpublished Work
© Registered Trademark of ABB Automation Inc.
™ Trademark of ABB Automation Inc.



ABB Automation Inc.
2175 Lockheed Way
Carson City
NV 89706 USA
Tel: +1 (0) 775-883-4366
Fax: +1 (0) 775-883-4373

ABB Instrumentation Ltd
Oldends Lane
Stonehouse, Glos.
England, GL10 3TA
Tel: +44 (0) 1453-826-661
Fax: +44 (0) 1453-827-856

ABB Automation Products GmbH
Heerdter Landstr. 193
D-40549 Düsseldorf
Tel: +49 (211) 50077300
Fax: +49 (211) 50077333

