

I/A Series® Hardware

PSS 21H-2W3 B4

DIN Rail Mounted Power Supply

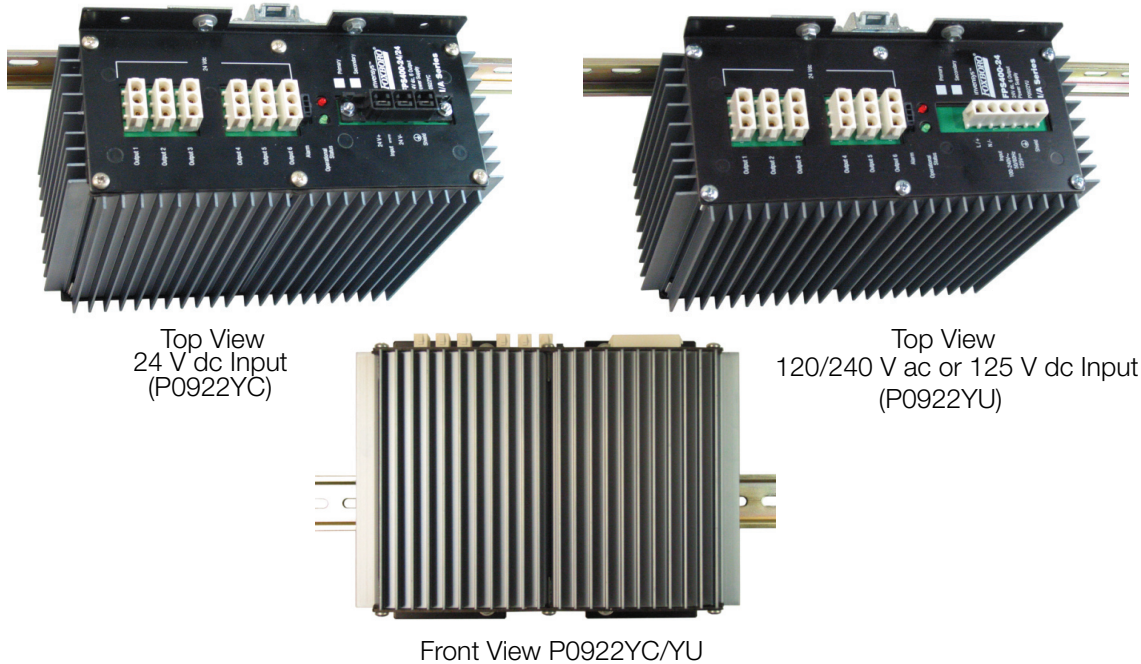

The I/A Series® system DIN rail mounted power supply provides 24 V dc to the DIN Rail Mounted Subsystem baseplates.

FEATURES:

- ▶ Wide range of ac and dc input voltages
- ▶ Extremely high efficiency
- ▶ Power factor correction
- ▶ Dual stage current limiting
- ▶ Overvoltage shut down circuitry
- ▶ Transformer isolated 24 V dc output
- ▶ Class 1, DIV 2, Zone 2 applications
- ▶ UL®, UL-C and CENELEC Certifications
- ▶ G3 rating for harsh environments
- ▶ Power for external field devices
- ▶ Convection cooling (no fans)
- ▶ Gasketed and sealed housing

- ▶ Horizontal or vertical DIN rail mounting
- ▶ Holes for bracket or wall mounting
- ▶ Relay (form C) status alarm output.

OVERVIEW

The I/A Series® system DIN rail mounted power supplies provide 24 V dc to DIN rail mounted baseplates. The Model FPS400-24 is a 400 W power supply that is agency certified for use in Division 2 and Zone 2 applications. Two different input voltage power supplies are offered as follows:

- ▶ 120/240 V ac or 125 V dc input (P0922YU)
- ▶ 24 V dc input (P0922YC).

These power supplies are the only power supplies that have been tested and qualified by Invensys for use with 200 Series FBMs.

WIDE-RANGE INPUT VOLTAGES

A high-efficiency input circuit automatically accepts either ac or dc input voltages. The 120/240 V ac or 125 V dc input circuit (P0922YU) provides a range of 85 to 265 V ac at 47 to 63 Hz operation (or 108 to 145 V dc) to meet world-wide power requirements.

The 24 V dc power supply input circuit (P0922YC) accepts a range of 18 V dc to 35 V dc.

HIGH EFFICIENCY

The sealed power supply has exceptional efficiency (up to 95% for P0922YU and up to 81% for P0922YC) resulting in high reliability and low failure rates. They have a return-on-investment (ROI) of less than two years based upon average electrical rates and load.

POWER FACTOR CORRECTION CIRCUITRY

The advanced design for ac inputs (P0922YU) provides an active sinusoidal current profile for near-unity controlled power factor.

CURRENT LIMITING

The power supply operates as a constant voltage source with maximum load ratings as listed in the specifications. If load current attempts to exceed greater than 110% of maximum current at the rated 25° C load, the output voltage begins to decrease toward zero, thereby limiting the current delivered to the load. Upon removal of overload, normal operation resumes.

OVERVOLTAGE SHUTDOWN

Automatic shutdown occurs if operating conditions cause excessive output voltage. After the occurrence of an overvoltage shutdown, input power must be interrupted to re-establish the output. After the cause

of the shutdown has been removed, the shutdown circuit resets in less than 30 seconds after the removal of input power.

DIVISION 2, ZONE 2 APPLICATION

The power supplies are UL and UL-C listed (to UL 1950) as having a Safety Extra Low Voltage (SELV) and can be used in Division 2 and Zone 2 applications.

POWER FOR EXTERNAL FIELD DEVICES

The actual amount of power required in a DIN rail mounted subsystem depends on the number of Fieldbus Modules (FBMs)/Fieldbus Communication Modules (FCMs)/Field Control Processors (FCPs) being powered, the types of termination assemblies used, and whether internal or external powering is used for the individual field device(s).

The FPS400-24 can also be used as a field power supply to power external field devices. However, for system integrity field devices and DIN rail baseplates should not be powered from the same FPS400-24.

PACKAGING

The robust gasketed design lends itself to minimal maintenance because the housing is sealed and there are no fans to wear out. The sealed gasketed design also provides protection for corrosive atmospheres such as hydrogen sulfides and chlorine, as found in many process control plants. The power supply has a DIN rail mounting bracket for mounting on a horizontal or vertical DIN rail. The bracket can be rotated for horizontal or vertical DIN rail mounting or removed for wall mounting of the power supply.

STATUS ALARMS

Visual LED indicators for undervoltage and normal operating voltage output are contained on the power supplies. To indicate the absence of 24 V dc output, a form C relay output is available to activate an externally powered alarm.

SIMPLIFIED WIRING

The power supply is designed to be used with special cables (ordered separately) to make

installation easy and improve personal safety. Refer to "PHYSICAL SPECIFICATIONS" on page 6.

FUNCTIONAL SPECIFICATIONS

Maximum Ratings

OUTPUT VOLTAGE

Factory set at 24.0 V dc

Input Specifications

120/240 V ac OR 125 V dc POWER SUPPLY (P0922YU)

INPUT VOLTAGE RANGE

85 to 265 V ac or 108 to 145 V dc, 125 V dc nominal (Refer to Table 1 and Table 3)

INPUT FREQUENCY RANGE

47 to 63 Hz

INPUT CURRENT

5.6 A at 85 V ac input (RMS maximum)
2.5 A at 230 V ac input (RMS maximum)

EFFICIENCY (AT MAXIMUM OUTPUT POWER)

77% minimum at 85 V ac input
85% typical at 120 V ac input
92% typical at 230 V ac input
90% typical at 240 V ac input

INRUSH CURRENT

20 A, at 110 V ac (peak at cold start)
40 A, at 220 V ac (peak at cold start)

INPUT POWER

453 W typical at 120 V ac, 50/60Hz
439 W typical at 230 V ac, 60 Hz
441 W typical at 230 V ac, 50 Hz

24 V dc POWER SUPPLY (P0922YU)

INPUT VOLTAGE RANGE

18 to 35 V dc, 24 V dc nominal

INPUT CURRENT

19.5 A at 24 V dc input

EFFICIENCY (AT MAXIMUM OUTPUT POWER)

85% typical at 24 V dc input

INPUT POWER

468 W at 24 V dc input typical

Output Specifications

OUTPUT VOLTAGE

24.0 V dc, ± 0.2 V dc nominal factory setting (Refer to Table 1 and Table 2)

VOLTAGE LINE REGULATION

2.0% of V_{out}

VOLTAGE LOAD REGULATION

2.0% of V_{out}

RIPPLE AND NOISE AT 20 MHz

100 mV (peak-to-peak), 10 mV (RMS maximum)

TEMPERATURE COEFFICIENT

0.025% per $^{\circ}$ C

STARTUP TIME (SOFT-START)

3 s typical at 110 V ac input or 24 V dc, 5 s maximum

OVERSHOOT

No overshoot at turn on, turn off, power failure or removal of short circuit

LOAD TRANSIENT RESPONSE

50 to 100% LOAD CHANGE

Recovery to within regulation limits within 50 ms
Maximum output voltage excursion less than 5%

Protection Features

OVER CURRENT PROTECTION

Current limiting to 110% of maximum at the rated 25° C load

OVERVOLTAGE PROTECTION

Factory set at 28.0 V dc for DIN rail
FBM/FCM/FCP applications

FUSING (NON-USER ACCESSIBLE)

10 A slow-blow 250 V ac/V dc internal fuse

ISOLATION VOLTAGES

3000 V ac input to output
500 V ac output to chassis ground
1500 V ac input to chassis ground

FUNCTIONAL SPECIFICATIONS (CONTINUED)

LEAKAGE CURRENT

ac line to chassis ground is less than 1.6 mA when operated at 250 V ac (47 to 63 Hz) or lower voltages

Vibration

0.75 g (5 to 500 Hz)

Regulatory Compliance (also see Table 3)

ELECTROMAGNETIC COMPATIBILITY (EMC)

European EMC Directive 89/336/EEC

Meets:

EN 50081-2 Emission standard

EN 50082-2 Immunity standard

EN 61326 Annex A (Industrial Levels)

CISPR 11, Industrial Scientific and Medical (ISM) Radio-frequency

Equipment - Electromagnetic Disturbance Characteristics - Limits and Methods of Measurement

Meets Class A Limits

IEC/EN 61000-4-2 ESD Immunity

4 kV contact, 8 kV air discharge

IEC/EN 61000-4-3 Radiated Field Immunity

10 V/m at 80 to 1000 MHz, 80% amplitude modulated at 1 kHz

IEC/EN 61000-4-4 Electrical Fast Transient/Burst Immunity (Repetitive transient wave)

2 kV common mode on mains input

IEC/EN 61000-4-5 Surge Immunity

4 kV line-to-ground

1 kV line-to-line

IEC/EN 61000-4-6 Immunity to Conducted Disturbances Induced by Radio-frequency Fields

10 V (rms) at 150 kHz to 80 MHz with 80% amplitude modulation at 1 kHz

IEC/EN 61000-4-8 Power Frequency Magnetic Field Immunity

100 A/m at 50 and 60 Hz

Levels up to 20 gauss 50/60 Hz

PRODUCT SAFETY

Underwriters Laboratories (UL) for U.S. and Canada

UL/UL-C listed as suitable for USA Class I, Zone 2, Aex nC IIC, and Class I, Division 2 Groups A, B, C, D Hazardous Locations, temperature code T3. These modules are also UL and UL-C listed as associated apparatus for supplying non-incendive communication circuits for Class I, Division 2, Groups A-D hazardous locations when connected to specified I/A Series processor modules as described in the *I/A Series system DIN Rail Mounted Subsystem User's Guide* (B0400FA).

European Low Voltage Directive 73/23/EEC and Explosive Atmospheres (ATEX) Directive 94/9/EC

CENELEC (TUV) certified as EEx nA IIC T3 for use in CENELEC certified Zone 2 enclosure certified as associated apparatus for supplying non-incendive field circuits for Zone 2, Group IIC, potentially explosive atmospheres when connected to specified I/A Series processor modules as described in the *I/A Series system DIN Rail Mounted Subsystem User's Guide* (B0400FA).

Calibration Requirements

Calibration or voltage adjustment of the power supply is not required.

FUNCTIONAL SPECIFICATIONS (CONTINUED)

Table 1. Nominal Input and Output

Input			Maximum Rated Output	
V	A	Hz	V	A
120 to 240 V ac	4.5/2.3	47 to 63	24	16.7
100 to 120	4.5	47 to 63	24	14.4
125 V dc	4.5		24	16.7
24 V dc	19.5		24	16.7

Table 2. Temperature Derating

Input Supply Voltage	Maximum Power (Watts) at Static Air Temperature (Static air temperature with zero air flow)					
	25°C	40°C	50°C	60°C	65°C	70°C
240 V ac	400	345	325	300	285	275
220 V ac	400	345	325	300	285	275
120 V ac	400	325	300	275	265	250
100 V ac*	345	315	300	275	265	250
120 V dc	400	330	300	280	270	250
24 V dc	400	330	300	280	270	250

* Below 100 V ac, derate 3 W per Volt

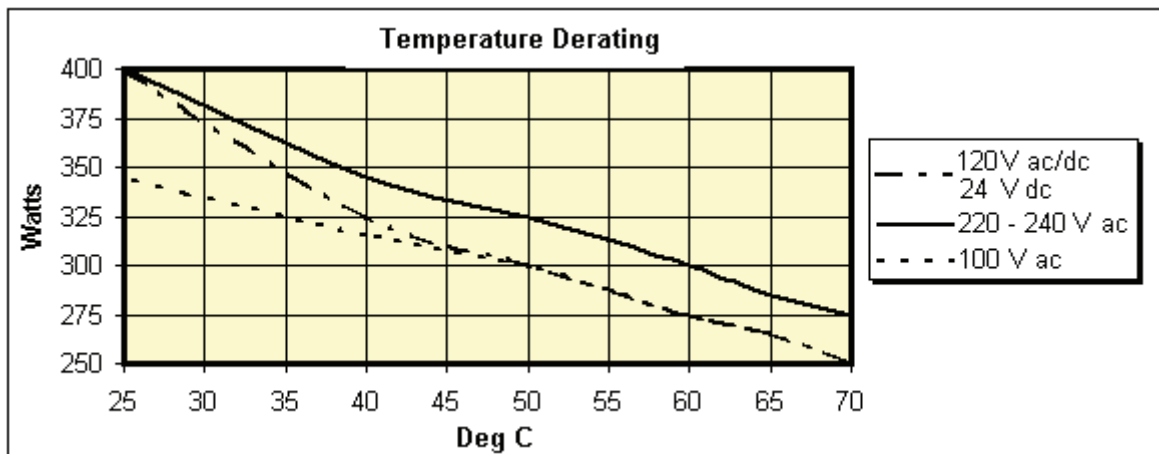

FUNCTIONAL SPECIFICATIONS (CONTINUED)

Table 3. Regulatory Compliance

Input			Maximum Rated Output (+), dc	
V	A	Hz	V	W
120/240 V ac	4.5/2.3	47 to 63	24	325/345
125 V dc	4.5		24	330
24 V dc	19.5		24	330

PHYSICAL SPECIFICATIONS

Mounting

Horizontal or vertical DIN-rail. Use DIN rail clamp (P/N X0175TQ) below the power supply when mounting on a vertical DIN rail. Panel mount with DIN rail mounting bracket and DIN rail clamp removed.

Mass

NET

2.67 kg (6.00 lb)

SHIPPING

6 kg (11.00 lb)

Dimensions

See "DIMENSIONS-NOMINAL" on page 8.

Cooling

Convection cooled (no fans)

Indicators

Red light-emitting diode (LED) indicates output undervoltage (<22 V dc). Green LED indicates when output is within specified operating range (>23.5 V dc).

Finish

BODY AND FRONT COVER

I/A Series system blue - extruded aluminum

TOP AND BOTTOM CAPS

Black - die cast aluminum

Fungus Inert

The power supply is fungus inert.

Part Numbers

POWER SUPPLY

P0922YU - 120/240 V ac or 125 V dc input

P0922YC - 24 V dc input

INPUT AC/DC TERMINAL BLOCK

Connects customer input power

P0926DZ - Qty 1 required

AC INPUT TERMINAL BLOCK CABLE

Connects Terminal Block to P0922YU Power Supply - Qty 1 required

- P0923DA - 0.4 m (15 in)
- P0926CM - 0.8 m (33 in).

DC INPUT TERMINAL BLOCK CABLE

Connects Terminal Block to P0922YC Power Supply - Qty 1 required

- P0923DH - 0.4 m (15 in)
- P0923DG - 0.8 m (33 in).

PHYSICAL SPECIFICATIONS (CONTINUED)

POWER SUPPLY TO BASEPLATES CABLES

Connects power supply to baseplates. Up to six cables (16 AWG -shielded) of any length listed below can be used per power supply. The output power supply connector is compatible with both the newer and older version of cables.

Newer version of baseplate power supply cables used with Modular Baseplates (P0926KE/HF/HJ/HM/HT/KH/HZ/JC/JF/JM):

- P0926KK - 0.4 m (16 in)
- P0923NG⁽¹⁾ (Y-Cable) - 0.5 m (20.5 in)
- P0926KL - 0.9 m (3 ft)
- P0926KM - 1.2 m (4 ft)
- P0926KN - 1.5 m (5 ft)
- P0926KP - 1.8 m (6 ft)
- P0926KQ - 2.1 m (7 ft).

Older version of baseplate power supply cables used with baseplates P0914XA/XB:

- P0926CA - 0.4 m (16 in)
- P0926CB - 0.9 m (3 ft)
- P0926CC - 1.2 m (4 ft)
- P0926CD - 1.5 m (5 ft)
- P0926CE - 1.8 m (6 ft)
- P0926CF - 2.1 m (7 ft).

ALARM STATUS RELAY OUTPUT CABLE

Alarm status output with a DIN rail mounted terminal block to connect form C relay output (compression connector) to an external indicator - Qty 1 required

- P0923DB - 1.2 m (4 ft)
- P0923DC - 1.5 m (5 ft)
- P0923DD - 1.8 m (6 ft)

Alarm Status Relay

TYPE

SPDT; NC, NO, COM

ALARM STATUS CONTACT VOLTAGE

<22 V dc, alarm, relay de energized

>23.5 V dc, power OK, relay energized

SWITCHING CURRENT

2 A ac and dc maximum

CURRENT CARRYING

3 A ac and dc maximum

SWITCHING POWER

60 W, 125 VA

UL/CSA RATING

2A at 30 V dc

(1) The P0923NG Y-cable is available for use on the FPS400 style power supplies to provide additional physical connections from the supply to multiple baseplates for situations where the six connections on the supply is the limiting factor. This new cable provides additional power connections capabilities. Users can connect to existing Invensys-supplied 3-pin power cables to allow for expansion. The "pin and socket" terminals on this Y-cable adapt to existing 3-pin power cables. The pin section attaches to the power supply, while the socket sections branch to the baseplates. Review your system product application to ensure that the connected equipment is within the power ratings as listed in this PSS.

DIMENSIONS-NOMINAL

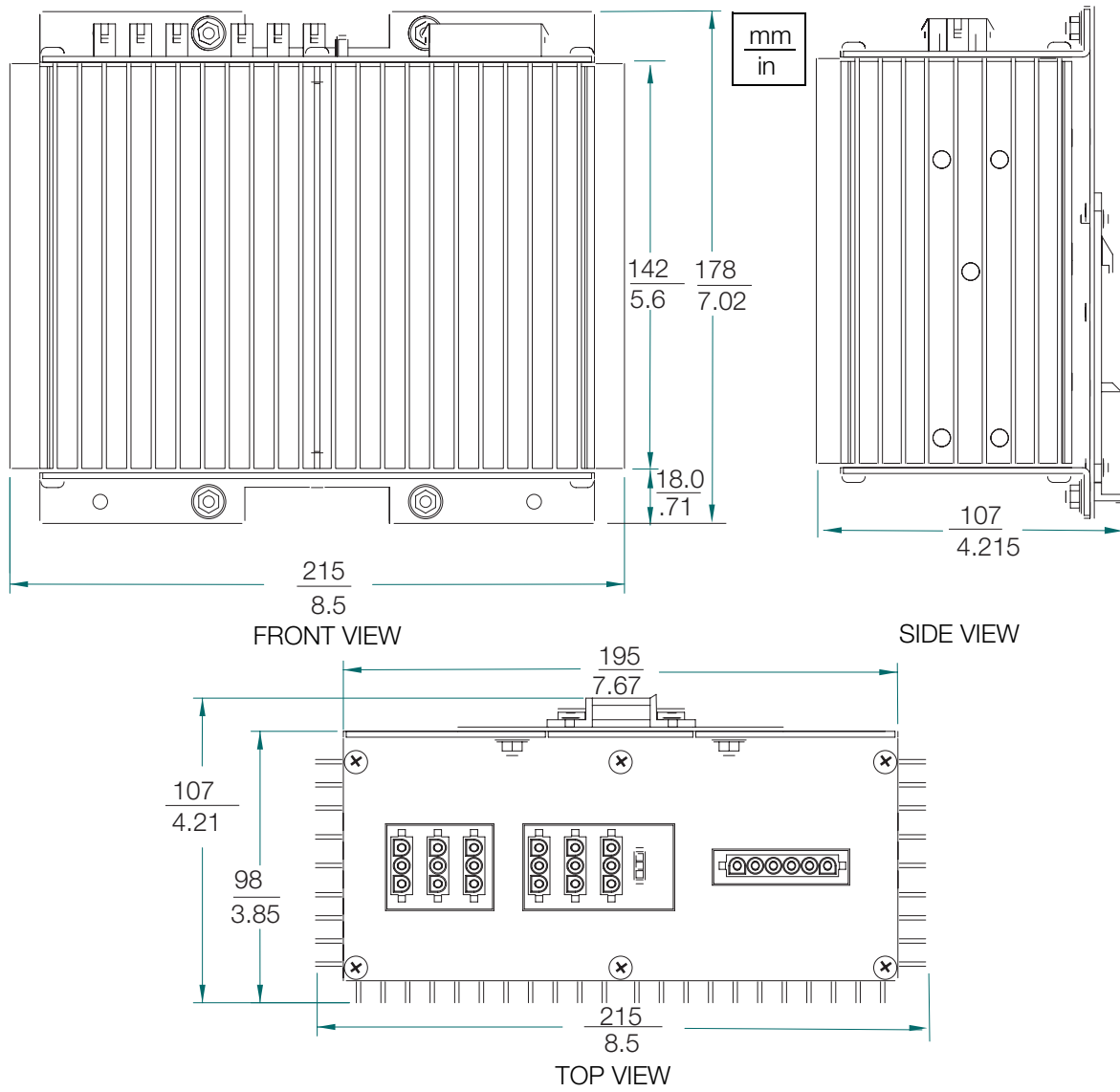

CLEARANCE-NOMINAL

NOTE:

The power supply can mount on a horizontal or vertical DIN rail. Use DIN rail clamp (P/N X0175TQ - not shown) below the power supply when mounted on a vertical DIN rail.

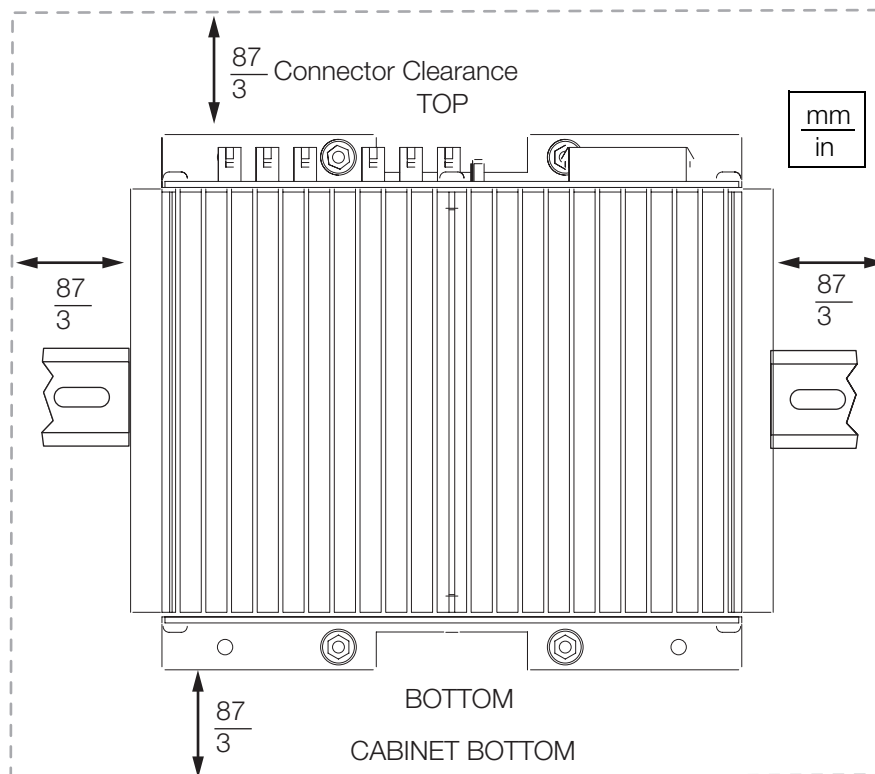

DIN RAIL/WALL MOUNT PLATE (REAR VIEW)

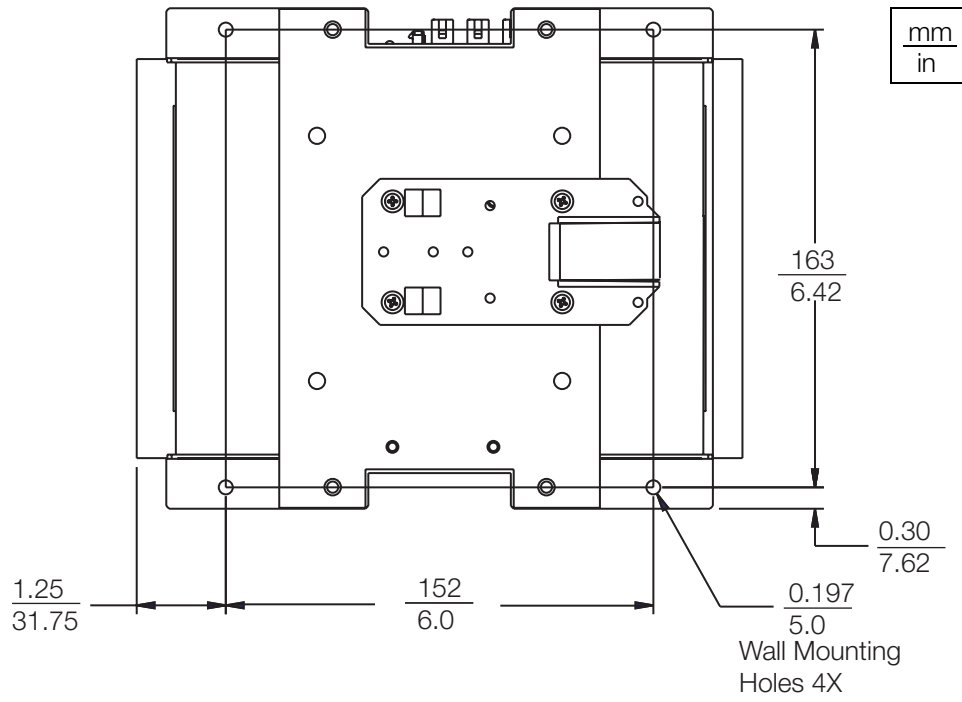



33 Commercial Street
Foxboro, MA 02035-2099
United States of America
www.foxboro.com
Inside U.S.: 1-866-746-6477
Outside U.S.: 1-508-549-2424
or contact your local Foxboro
representative.
Facsimile: 1-508-549-4999

Invensys, Foxboro, and I/A Series are trademarks of Invensys plc, its subsidiaries, and affiliates.
All other brand names may be trademarks of their respective owners.

Copyright 1999-2007 Invensys Systems, Inc.
All rights reserved

MB 21A

Printed in U.S.A.

0307