

I/A Series[®] Hardware Fieldbus Communications Module, FCM10Ef



The FCM10Ef Fieldbus Communications Module is a fiber optic communications interface which allows the DIN rail mounted Fieldbus Modules (FBMs) to communicate with the I/A Series control station over extended distances using fiber optic cabling. The FCM10Ef modules provide expanded networking, easy customization, and greater overall cabling distances in a fiber optic network (see Figure 1). This configuration is ideally suited for sites in which groups of FBMs are to be spread apart over greater distances.

FCM10Ef modules are used with multiport fiber optic converters (hubs), which connect to the I/A Series control station via the high-speed, optionally redundant 10 Mbps Ethernet trunk Fieldbus.

Up to six groupings of baseplate-mounted FCM10Ef modules and FBMs can be linked to each optionally redundant multiport fiber optic converter (hub), for a maximum of 120 FBMs per I/A Series control station (depending on selected scan periods). To support redundancy, a pair of FCM10Ef modules must be used for each FBM grouping. In non-redundant configurations, only a single FCM10Ef is required for each grouping.

Signal transmission distances up to 2 km (1.24 mi) are possible between the FCM10Ef modules and the multi-port fiber optic converters (hubs), providing for wide distribution of the FBM equipment groupings.

Extended transmission distances, using fiber optic cabling, are also possible within the groupings, and between the multiport fiber optic converter (hub) and the I/A Series control station. (Refer to PSS 21H-2W1 B3, for details.)

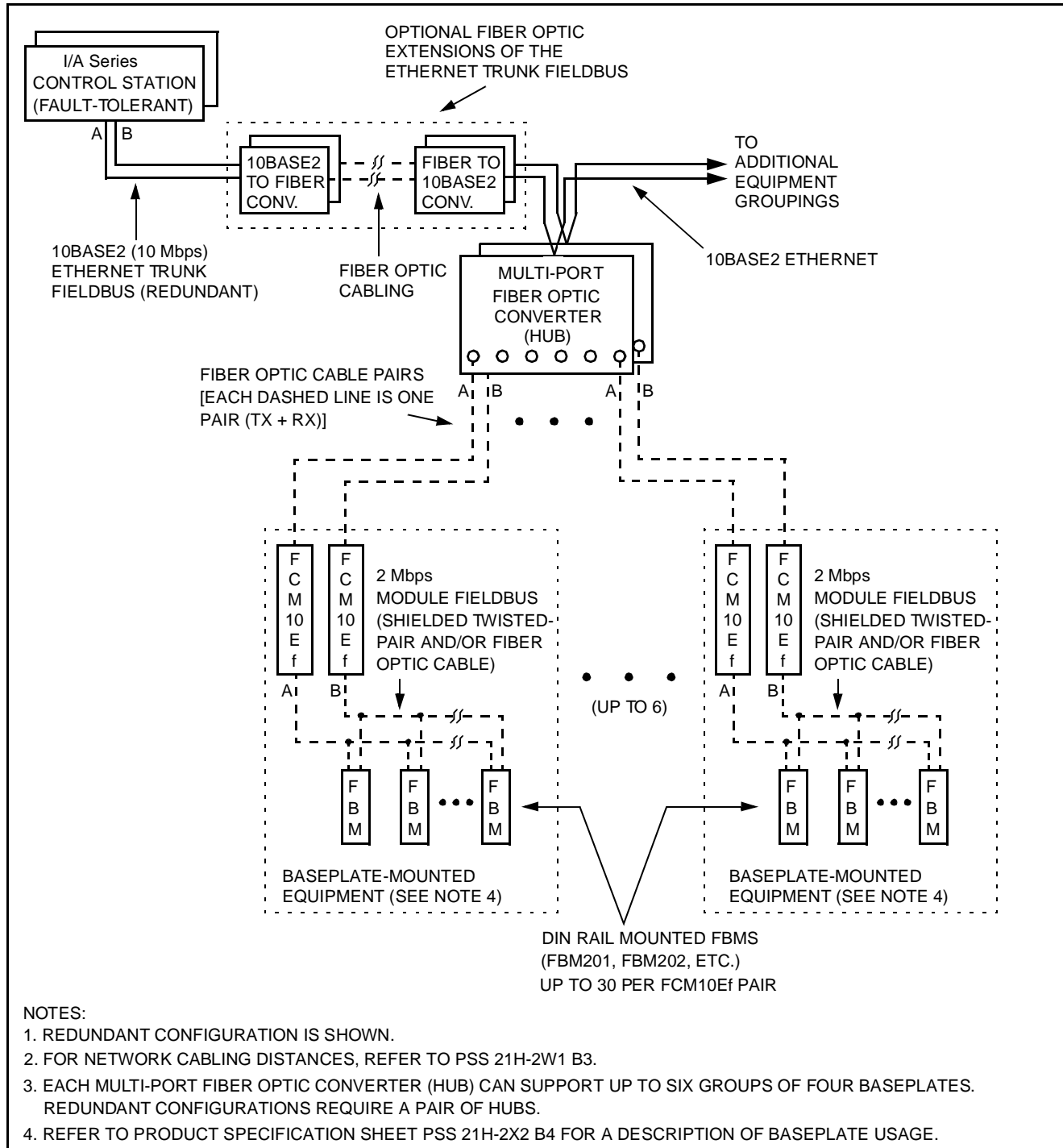

Figure 1. Typical Star Communications Network Using FCM10Ef Modules

FIBER OPTIC CABLING

Unaffected by electrical noise (EMI, RFI, and lightning), fiber optic cabling provides a versatile, highly reliable means of extending signal communications. It can be used in areas containing rotating machinery, arc welders, and so forth, and can be installed in cable trays containing high voltage power lines, or in outdoor areas exposed to lightning hazards. Its electrical isolation characteristics provide protection from voltage differentials and ground loops.

Fiber optic cabling used in this configuration is purchased by the customer. The recommended fiber optic cable is a multimode, graded-index glass fiber with a 62.5 micron core and 125 micron cladding with 0.275 NA (numerical aperture).

Maximum allowable signal loss is 1 dB per km at a wavelength of 1300 nm, and 3.6 dB per km at a wavelength of 850 nm. Cables with different characteristics may not be used. Four fiber optic cables are required for redundancy, two for transmit and two for receive connections. For this reason, it is recommended that the customer purchase duplex cabling, which consists of two fibers intertwined in a single cable. The cables must be terminated with ST-type connectors and cable length may not exceed that specified for the module.

Other cable requirements (such as flexibility, or durability) depend on the particular application. Check with your cable vendor/installer for a listing of application-specific cable characteristics.

FCM10Ef MODULE DESIGN

FCM10Ef modules convert 2 Mbps signals used by the FBMs, to 10 Mbps fiber optic Ethernet signals used with fiber optic cabling, and vice versa.

FCM10Ef modules have a compact design, with a rugged extruded aluminum exterior for physical protection of the circuits. Enclosures specially designed for mounting of the FBMs and FCMs provide various levels of environmental protection for the FCM10Ef modules, up to harsh environments per ISA Standard S71.04.

The FCM10Ef can be removed/replaced from the baseplate without removing power.

Six light-emitting diodes (LEDs) incorporated into the front of the FCM10Ef indicate the status of network activity to/from the associated FBMs, and the FCM10Ef module's operational status.

FUNCTIONAL SPECIFICATIONS

Power Requirements

INPUT VOLTAGE RANGE (REDUNDANT)

24 V dc +5%, -10%

CONSUMPTION

7 W (maximum) at 24 V dc

HEAT DISSIPATION

7 W (maximum) at 24 V dc

Vibration

0.75 g (5 to 200 Hz)

Calibration Requirements

Calibration of the module is not required.

Regulatory Compliance

ELECTROMAGNETIC COMPATIBILITY (EMC)

European EMC Directive 89/336/EEC

EN 50081-2 Emission standard

EN 50082-2 Immunity standard

IEC 61000-4-2 ESD Immunity

Contact 4 kV, air 8 kV

IEC 61000-4-3 Radiated Field Immunity

10 V/m at 80 to 1000 MHz

IEC 61000-4-4 Electrical Fast Transient/Burst Immunity

2 kV

IEC 61000-4-5 Surge Immunity

2 kV

IEC 61000-4-6 Immunity to Conducted Disturbances

10 V

IEC 61000-4-8 Power Frequency Magnetic Field Immunity

30 A/m

IEC 61000-4-11 Voltage Dips, Short Interruptions and Voltage Variations Immunity

Regulatory Compliance (Cont.)

PRODUCT SAFETY

European Low Voltage Directive 73/23/EEC

PRODUCT CERTIFICATION

Underwriters Laboratories (UL)

UL/UL-C listed as suitable for use in UL/UL-C

listed Class I, Groups A-D; Division 2;

temperature code T4 enclosure based systems.

The modules are also UL and UL-C listed as

associated apparatus for supplying non-

incendive communication circuits for Class I,

Groups A-D hazardous locations when

connected to specified I/A Series processor

modules as described in the *I/A Series DIN Rail*

Mounted FBM Subsystem User's Guide

(B0400FA). Communications circuits also meet

the requirements for Class 2 as defined in Article

725 of the National Electrical Code (NFPA No.70)

and Section 16 of the Canadian Electrical Code

(CSA C22.1). Conditions of use are as specified

in the *I/A Series DIN Rail Mounted FBM*

Subsystem User's Guide (B0400FA).

CENELEC

CENELEC (DEMKO) certified as EEx nA IIC T4

for use in CENELEC certified Zone 2 enclosure

based systems. The modules are CENELEC

certified as associated apparatus for supplying

non-incendive field circuits for Zone 2, Group IIC,

potentially explosive atmospheres when

connected to specified I/A Series processor

modules as described in the *I/A Series DIN Rail*

Mounted FBM Subsystem User's Guide

(B0400FA).

EUROPEAN UNION COMPLIANCE

Meets all applicable European Union directives

including the Explosive Atmospheres (ATEX)

directive 94/9/EC, and bears the CE mark.

ENVIRONMENTAL SPECIFICATIONS(a)**Operating**

TEMPERATURE

-20 to +70°C (-4 to +158°F)

RELATIVE HUMIDITY

5 to 95% (noncondensing)

ALTITUDE

-300 to +3,000 m (-1,000 to +10,000 ft)

Storage

TEMPERATURE

-40 to +70°C (-40 to +158°F)

RELATIVE HUMIDITY

5 to 95% (noncondensing)

ALTITUDE

-300 to +12,000 m (-1,000 to +40,000 ft)

Contamination

Class G3 (Harsh) as defined in ISA Standard, S71.04. Pollution degree 2 as defined in IEC 664-1.

(a) The environmental limits of this module may be enhanced by the type of enclosure containing the module. [Refer to the applicable Product Specification Sheet (PSS) which describes the specific type of enclosure that is to be used.]

PHYSICAL SPECIFICATIONS**Mounting**

FCM10Ef mounts on a baseplate. The baseplate can be mounted on a DIN rail (horizontally or vertically), or horizontally on a 19-inch rack using a mounting kit. Refer to PSS 21H-2X2 B4 for details.

Mass

284 g (10 oz) approximate

Dimensions

HEIGHT

102 mm (4 in)

114 mm (4.5 in) including mounting lugs

WIDTH

45 mm (1.75 in)

DEPTH

104 mm (4.11 in)

Indicators (mounted on front of module)

Red and green light-emitting diodes (LEDs) provide indication of the FCM operational status. Amber LEDs indicate data traffic and direction.

The Foxboro Company

33 Commercial Street
Foxboro, Massachusetts 02035-2099
United States of America

<http://www.foxboro.com>

Inside U.S.: 1-508-543-8750 or 1-888-FOXBORO (1-888-369-2676)

Outside U.S.: Contact your local Foxboro representative.

Foxboro and I/A Series are registered trademarks of The Foxboro Company.

Copyright 1999-2000 by The Foxboro Company

All rights reserved