

I/A Series® Hardware

PSS 21H-2Z24 B4

FBM224 Modbus® Communication Interface Module



The FBM224 Modbus® Communication Interface Module provides an interface between Modbus slave devices and the Control Processor of the I/A Series® system.

FEATURES

Key features of the FBM224 module are:

- ▶ Conforms to Modbus protocol
- ▶ Offers a choice of RS-232, RS-422, or RS-485 communication interface standard
- ▶ Integrates Modbus slave device data into an I/A Series control database
- ▶ With its associated termination assembly (TA), is suitable for installation in Class 1, Division 2 and Zone 2 locations.

OVERVIEW

The FBM224 Modbus Communication Interface Module provides an interface between Modbus slave devices — such as programmable logic controllers and field I/O devices — and the Control Processor (CP60, ZCP270, or FCP270) of the I/A Series system. Devices with which the FBM224 can successfully communicate are those which support RS-232, RS-422, or RS-485 communication interface standards and the Modbus protocol in RTU mode. The FBM224 supports the Modbus function codes from the list in Table 1.

Table 1. Modbus Protocol Function Codes

Function Code	Description
01	Read Coil Status
02	Read Input Status
03	Read Holding Registers
04	Read Input Registers
05	Force Single Coil
06	Preset Single Register
08	Loopback Diagnostic Test
15	Force Multiple Coils
16	Preset Multiple Registers

Physical Modbus wiring is in accordance with Electronic Industrial Association (EIA) standard RS-232, RS-422, or RS-485.

The general Modbus network configurations are shown in Figure 1.

The FBM224 has four ports - each can be individually configured for RS-232, RS-422, or RS-485 allowing you to connect a single FBM224 to any communication interface standard used by Modbus networks. Ports 1 and 2 and/or Ports 3 and 4 can be configured as a single logical port with redundant cables allowing you to interface with dual ported Modbus devices within your plant.

The FBM224 (Figure 1) and its associated termination assembly (TA) accommodate several types of connections to devices: single ported and/or dual ported device connections (Figure): direct connection to devices: connection to modems when used with the RS-232 communication interface: RS-232 converters to RS-422 and RS-485: and intrinsic safety protective devices between the TA and the slave device.

The FBM224 communicates with the Modbus I/O devices on a master/slave basis. As master, the FBM224 initiates each data exchange. The slave devices only respond to the master when requested to do so. Modbus slave devices are polled cyclically for input data at a user-configured frequency. Output requests from the Control Processor are honored immediately on receipt by the FBM224, independently of the configured poll frequency.

SERIAL LINK SETUP

Data communication between the FBM224 and Modbus slave devices are through the 4-ported termination assembly (TA). The TA has compression terminals for each port for RS-422 and RS-485 wiring, with DIP-switch-selectable bus termination resistors per port. For RS-232 wiring, the TA has a standard DB-25 male connector and a break-out bank of 24 DIP switches for each port that can be used for any RS-232 wiring configuration (for example, to connect Clear-to-Send to Request-to-Send).

CONFIGURATORS

Two configurators are provided, Windows® or Solaris® versions, for the setup of FBM224 port and slave configuration files. The port configurator allows for easy setup of the communication parameters for each port (such as, communication interface standard, baud rate, parity). The device transaction configurator allows for easy setup of the transaction specifications for slave device files (such as, scan rate, function code, start address of the data to be transferred, and the amount of data to be transferred in one transaction). Up to 64 separate transactions can be specified for each Modbus device. During configuration, the selected values and supported options are automatically checked for range validity.

OPERATIONS

Each FBM224 can access up to 64 devices to read or write data.

From the I/A Series control station to which the FBM224 is connected (refer to Figure), up to 2000 Distributed Control Interface (DCI) data connections can be made to read or write data. A connection can be to:

- ▶ An analog input or output value (integer or IEEE single-precision floating point)
- ▶ A single digital input or output value
- ▶ Multiple (packed) digital input or output values (packed in groups of up to 32 digital points per connection).

Thus an I/A Series® control station can access up to 2000 analog I/O values, or up to 32,000 digital I/O values, or a combination of digital and analog values spread over the four ports of the FBM224. The frequency of access to the FBM224 data by a control station can be as fast as 500 ms. The performance is dependant on each device type and the layout of data in the device.

The FBM224 collects the required data from the devices, performs the necessary conversions, and then stores the converted data in its database for incorporation into the I/A Series system plant management functions and operator displays. Data may also be written out to the individual devices from the I/A Series network.

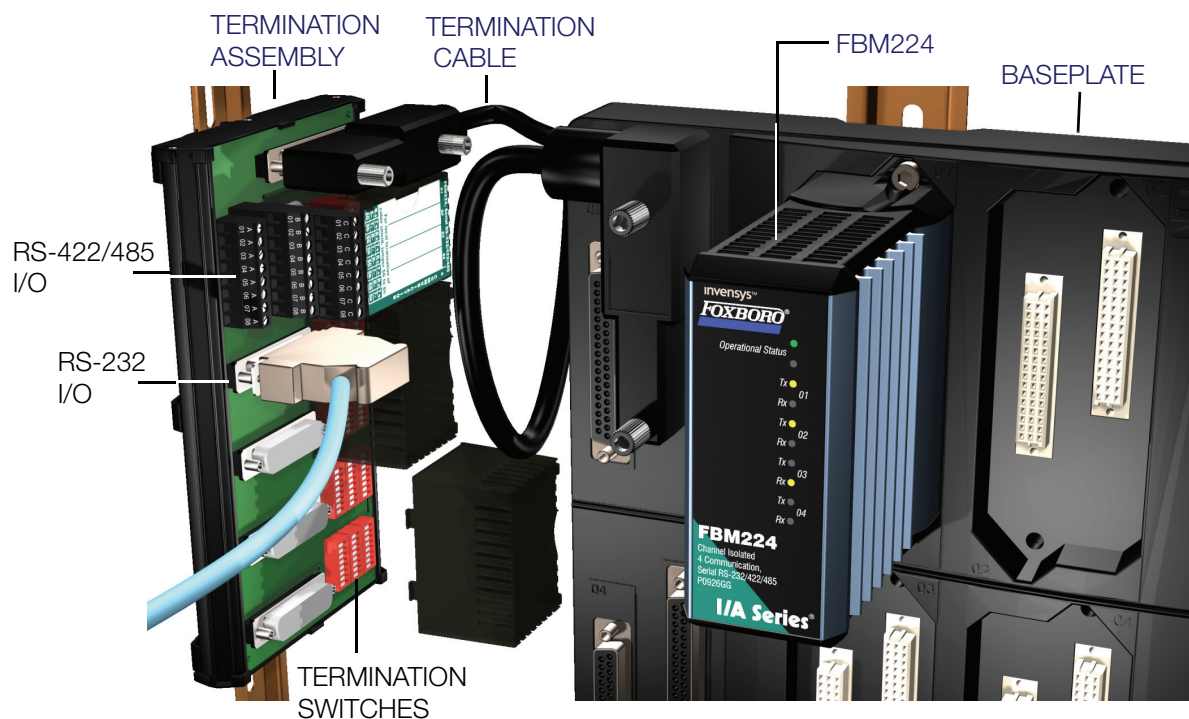
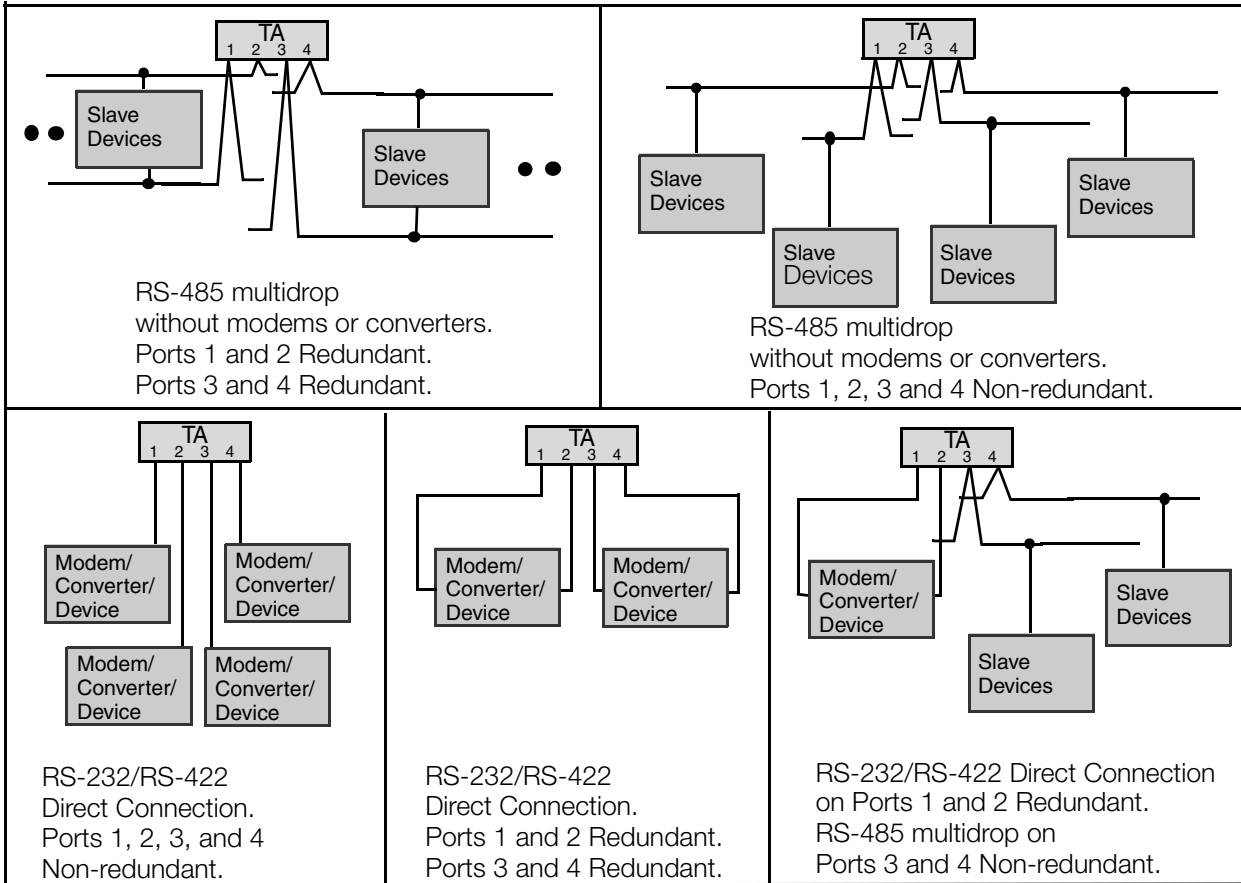
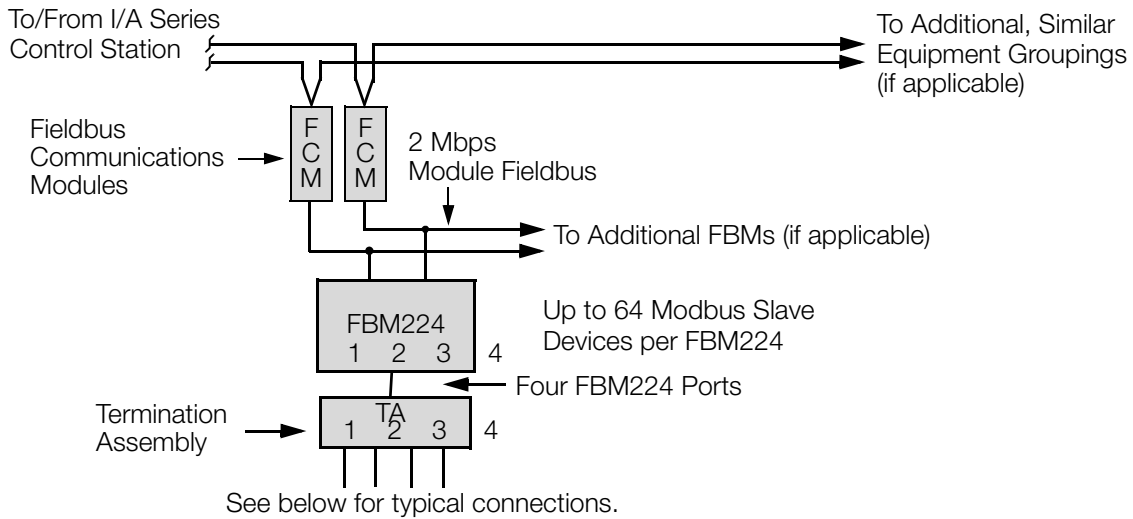

Figure 1. FBM224 I/O Connections



NOTES: Each FBM224 port can be configured for RS-232, RS-422, or RS-485 communication standards. Ports 1 and 2, and/or 3 and 4 can be configured for dual ported devices.

Figure 2. FBM224 in Typical Modbus Network Configurations

PHASE AND SCAN RATE

During a basic scan cycle, the FBM224 performs all scheduled read/write transactions to each Modbus device. Users can adjust the Scan Rate and Phase for each cycle to reduce the loading on the FBM224 and/or on the Modbus device.

The Scan Rate specifies the periodic processing of device transactions as a multiple of the basic scan cycle. The default is 500 ms. The range is {500 ms, 1 sec, 2 sec, and so forth, up to 255 sec}.

The Phase specifies the exact scan cycle to perform the device transactions when the Scan Rate is a multiple of the basic scan cycle.

CONTROL BLOCK SUPPORT

The FBM224 offers control block support for the following standard I/A Series Distributed Control Interface (DCI) block types:

BIN	Binary Input
BINR	Binary Input Redundant
BOUT	Binary Output
IIN	Integer Input
IOUT	Integer Output
PAKIN	Packed Input
PAKOUT	Packed Output
PLSOUT	Pulse Output
RIN	Real Input
RINR	Real Input Redundant
ROUT	Real Output

The I/A Series Configuration Component (IACC), Integrated Control Configurator (ICC), or FoxCAE™ software is used to configure the DCI blocks in the control processor. The DCI blocks address and read/write data from/to the addressed slave device.

COMPACT DESIGN

The FBM224 has a compact design, with a rugged extruded aluminum exterior for physical and electrical protection of the circuits. Enclosures, specially designed for mounting the FBMs, provide various levels of environmental protection, up to harsh environments per ISA Standard S71.04.

BASEPLATE MODULE MOUNTING

The module mounts on a baseplate (see Figure 1), which accommodates up to four or eight FBMs. The baseplate is either DIN rail mounted or rack mounted. The baseplate includes signal connectors for the FBMs, redundant independent dc power connections, and I/O cable connections.

EASY REMOVAL/REPLACEMENT

The module can be removed or replaced without removing field device termination cabling, power, or communications cabling.

FIELDBUS COMMUNICATION

A Fieldbus Communications Module or a Control Processor interfaces to the redundant 2 Mbps module Fieldbus used by the FBMs. The FBM224 accepts communication from either path (A or B) of the redundant 2 Mbps Fieldbus — should one path fail or be switched at the system level, the module continues communication over the active path.

VISUAL INDICATORS

Light-emitting diodes (LEDs) incorporated into the front of the module provide visual indication of the module's operational status, and the communication activity of the four communication ports.

TERMINATION ASSEMBLY

Features

Key features include:

- ▶ Combination foot that supports 32 or 35 mm DIN rail mounting
- ▶ Distinct family group color
- ▶ Three-tier termination for RS-422 and RS-485 and four DB-25 cable connectors for RS-232 communication interfaces
- ▶ Switches to select transmit and receive signals and other RS-232 communication signals
- ▶ Switch-selectable termination resistors for RS-422 and RS-485 communication.

Overview

Field I/O signals connect to the FBM subsystem via DIN rail mounted termination assemblies (TAs).

Each FBM224 termination assembly (see Figure 1) and its associated termination cable provide connection compliance to the electrical interface standards (RS-232, RS-422 or RS-485) between the field devices and the FBM224 Modbus Communication Interface Module.

The TA has four DB-25 cable connectors for RS-232 communication interface and switches to match the RS-232 signal pinout of the DB-25 connectors to various slave devices.

The TA has a three-tier compression type or ring lug connection for RS-422 and RS-485 communication interfaces. Switch-selectable termination resistors are built into the TA for active termination when used with RS-422 and RS-485 communication interfaces. TAs are available in Polyamide (PA) material.

The DIN rail mounted TAs connect Modular Baseplate by means of a removable termination cable. The cable is available in a variety of lengths, up to 5 meters (16 feet), allowing the TA to be mounted in either the enclosure or in an adjacent enclosure.

FUNCTIONAL SPECIFICATIONS

Modbus Communications

INTERFACE

Four serial I/O communication ports provide interface to up to four Modbus buses (RS-232, RS-422 and/or RS-485). Ports 1 and 2, and/or Ports 3 and 4 can be user-configured to function as a single logical port with redundant cables to dual ported devices.

BUS CHARACTERISTICS

General

Electronic Industrial Association (EIA) RS-232, RS-422 or RS-485 communications selectable on a per port basis. The RS-485 physical communication medium consists of twisted-pair shielded copper cable containing a single conductor pair. The RS-422 is a 4-wire physical communication medium. The RS-232 physical communication medium is a DB-25 cable to a customer supplied device.

EIA RS-232, RS-422 and RS-485 I/O Communication

Type

Asynchronous communication, direct connect link (RS-232)

Transmission Rate

300, 600, 1200, 2400, 4800, 9600, 19,200, 38,400, 57,600 and 115,200 baud

Protocol

Modbus protocol in RTU mode. 8-bit characters; odd, even or no parity, 1 or 2 stop bits.

I/O CAPACITY

Up to 64 devices per FBM224 maximum (number of actual devices is performance dependent) with up to 2000 DCI point connections.

SCAN RATE OF DEVICE

0.5, 1 to 255 seconds selectable at configuration time.

DEVICE ADDRESS RANGE

1 to 247

DATA TYPES TRANSFERRED

2-byte or 4-byte signed or unsigned integers, 4-byte IEEE single-precision floating values, or binary values. Byte and bit swapping are selectable.

FBM224 channel isolation

Each communication channel is galvanically isolated and referenced to earth (ground). The module can withstand, without damage, a potential of 600 V ac applied for one minute between either channel and earth.

CAUTION

This does not imply that the channels are intended for permanent connection to voltages of these levels. Exceeding the limits for input voltages, as stated elsewhere in this specification, violates electrical safety codes and may expose users to electric shock.

Fieldbus Dual Communication

Communicates with its associated FCM or CP via the redundant 2 Mbps module Fieldbus.

FBM224 Power Requirements**INPUT VOLTAGE RANGE (REDUNDANT)**

24 V dc +5%, -10%

CONSUMPTION

7 W (maximum)

HEAT DISSIPATION

7 W (maximum)

Regulatory Compliance**ELECTROMAGNETIC COMPATIBILITY (EMC)*****European EMC Directive 89/336/EEC***

Meets: EN 50081-2 Emission standard
EN 50082-2 Immunity standard
EN 61326 Annex A (Industrial Levels)

CISPR 11, Industrial Scientific and Medical (ISM) Radio-frequency Equipment - Electromagnetic Disturbance Characteristics - Limits and Methods of Measurement

Meets: Class A Limits

IEC 61000-4-2 ESD Immunity

Contact 4 kV, air 8 kV

IEC 61000-4-3 Radiated Field Immunity

10 V/m at 80 to 1000 MHz

IEC 61000-4-4 Electrical Fast Transient/Burst Immunity

2 kV on I/O, dc power and communication lines

IEC 61000-4-5 Surge Immunity

2 kV on I/O, dc power and communication lines

IEC 61000-4-6 Immunity to Conducted Disturbances Induced by Radio-frequency Fields

10 V (rms) at 150 kHz to 80 MHz on I/O, dc power and communication lines

IEC 61000-4-8 Power Frequency Magnetic Field Immunity

30 A/m at 50 and 60 Hz

IEC 61000-4-11 Voltage Dips, Short Interruptions and Voltage Variations Immunity

Compliant

PRODUCT SAFETY***Underwriters Laboratories (UL) for U.S. and Canada***

UL/UL-C listed as suitable for use in UL/UL-C listed Class I, Groups A-D; Division 2; temperature code T4 enclosure based systems. These modules are also UL and UL-C listed as associated apparatus for supplying non-incendive communication circuits for Class I, Groups A-D hazardous locations when connected to specified I/A Series® processor modules as described in the *Modbus Communication Interface Module (FBM224) User's Guide* (B0400FK). Communications circuits also meet the requirements for Class 2 as defined in Article 725 of the National Electrical Code (NFPA No.70) and Section 16 of the Canadian Electrical Code (CSA C22.1). Conditions for use are as specified in the *Modbus Communication Interface Module (FBM224) User's Guide* (B0400FK).

**European Low Voltage Directive
73/23/EEC and Explosive Atmospheres
(ATEX) Directive 94/9/EC**

CENELEC (DEMKO) certified as EEx nA IIC T4 for use in CENELEC certified Zone 2 enclosure certified as associated apparatus for supplying non-incendive field circuits for Zone 2, Group IIC, potentially explosive atmospheres when connected to specified I/A Series processor modules as described in the *I/A Series DIN Rail Mounted Subsystem User's Guide* (B0400FA).

Calibration Requirements

Calibration of the module and termination assembly is not required.

ENVIRONMENTAL SPECIFICATIONS⁽¹⁾

Operating

TEMPERATURE

FBM224 Module

-20 to +60° C (-4 to +140° F)

Termination Assembly

-20 to +70° C (-4 to +158° F)

RELATIVE HUMIDITY

5 to 95% (noncondensing)

Storage

TEMPERATURE

-40 to +70° C (-40 to +158° F)

RELATIVE HUMIDITY

5 to 95% (noncondensing)

Contamination

Suitable for use in Class G3 (Harsh) environments as defined in ISA Standard S71.04, based on exposure testing according to EIA Standard 364-65, Class III.

Vibration

7.5 m/S² (0.75 g) from 5 to 500 Hz

(1) The environmental limits of the module may be enhanced by the type of enclosure containing the module. Refer to the applicable Production Specification Sheet (PSS) which describes the specific type of enclosure that is to be used.

PHYSICAL SPECIFICATIONS

Mounting

MODULE

The FBM224 mounts on a Modular Baseplate. The Modular Baseplate can be mounted horizontally or vertically on a DIN rail, or mounted horizontally in a 19-inch rack using a mounting kit. Refer to PSS 21H-2W6 B4 for details.

TERMINATION ASSEMBLY

The TA accommodates multiple DIN styles including 32 mm (1.26) and 35 mm (1.38 in) rails.

Mass

MODULE

284 g (10 oz) approximate

TERMINATION ASSEMBLIES

Compression

216 mm (8.51 in) – 320 g (0.70 lb, approximate)

Ring Lug

250 mm (9.85 in) – 454 g (1.0 lb, approximate)

Part Numbers

MODULE

P0926GG

TERMINATION ASSEMBLIES

P0926GH - Compression Screw

P0926PA - Ring Lug

Dimensions

FBM224 MODULE

HEIGHT

102 mm (4 in)

114 mm (4.5 in) including mounting lugs

WIDTH

45 mm (1.75)

DEPTH

104 mm (4.11 in)

TERMINATION ASSEMBLIES

See page 11 and page 12

Indicators (mounted on front of module)

OPERATIONAL STATUS

1 red and 1 green light-emitting diode (LED)

CHANNEL COMMUNICATION ACTIVITY

8 Amber LEDs: one transmit and one receive per port.

Input/Output Cable Lengths

MAXIMUM CABLE LENGTH, TA RS-232

CONNECTION (DB-25 CABLE) TO MODEM/CONVERTER/DEVICE

15 m (50 ft) for custom cables per EIA Standard RS-232. With Foxboro standard cables 13 m (40 ft), refer to *Modbus Communication Interface Module (FBM224) User's Guide (B0400FK)*

MAXIMUM CABLE LENGTH, RS-422 AND RS-485

1200 m (3960 ft)

Termination Cables

CABLE LENGTHS

Up to 5 m (15 ft)

CABLE MATERIALS

Hypalon®/XLP.

TERMINATION CABLE TYPE

Type 5 - Refer to Table 2 on page 10

CABLE CONNECTION

37-pin male D-subminiature, TA and baseplate

Construction - Termination Assembly

MATERIAL

Polyamide (PA), compression and ring lug

FAMILY GROUP COLOR

Dark blue - discrete

TERMINAL BLOCKS FOR RS-422/RS-485

3 tiers, 8 positions

CABLE CONNECTORS FOR RS-232

DB-25, four connectors

PHYSICAL SPECIFICATIONS (CONTINUED)

Field Termination Connections for RS422/RS-485

COMPRESSION - ACCEPTED WIRING SIZES

Solid/Stranded/AWG

0.2 to 4 mm²/0.2 to 2.5 mm²/24 to 12 AWG

Stranded with Ferrules

0.2 to 2.5 mm² with or without plastic collar

RING-LUG - ACCEPTED WIRING SIZES

#6 size connectors (0.375 in (9.5 mm))

0.5 to 4 mm²/22 AWG to 12 AWG

Table 2. Hypalon/XLPE Termination Cable Types and Part Numbers

Length m (ft)	Hypalon/XLPE ^(a) Type 5
1.0 (3.2)	P0926GJ
3.0 (9.8)	P0926GQ
5.0 (16.4)	P0926GR

(a) H/XLPE is Hypalon outer jacket and XLPE (cross-linked polyethylene) primary conductor insulation. H/XLPE is rated from -40 to +90°C (-40 to 194°F)

RELATED PRODUCT SPECIFICATION SHEETS

PSS Number	Description
PSS 21H-2W1 B3	DIN Rail Mounted FBM Subsystem Overview
PSS 21H-2W2 B3	DIN Rail Mounted FBM Equipment, Agency Certifications
PSS 21H-2W6 B4	DIN Rail Mounted Modular Baseplates

DIMENSIONS - NOMINAL

Compression Screw Termination Assembly (P0926GH)

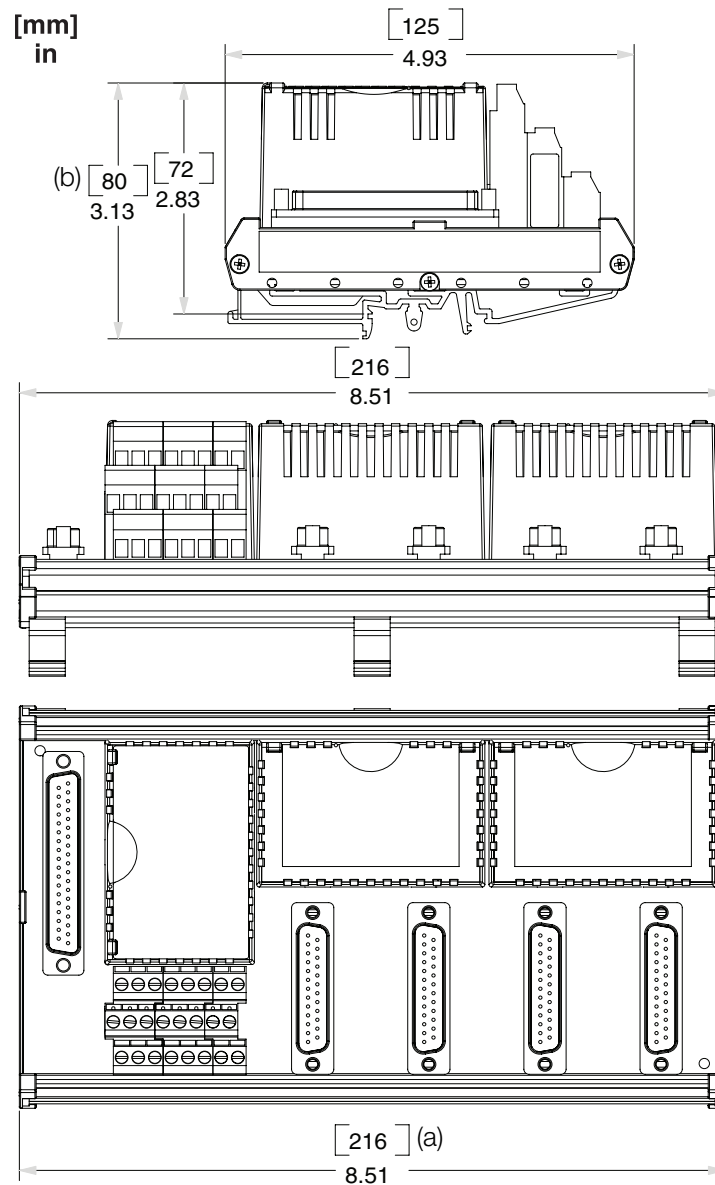

- (a) Overall width – for determining DIN rail loading.
- (b) Height above DIN rail (add to DIN rail height for total).

DIMENSIONS - NOMINAL

RING LUG Termination Assembly (P0926PA)

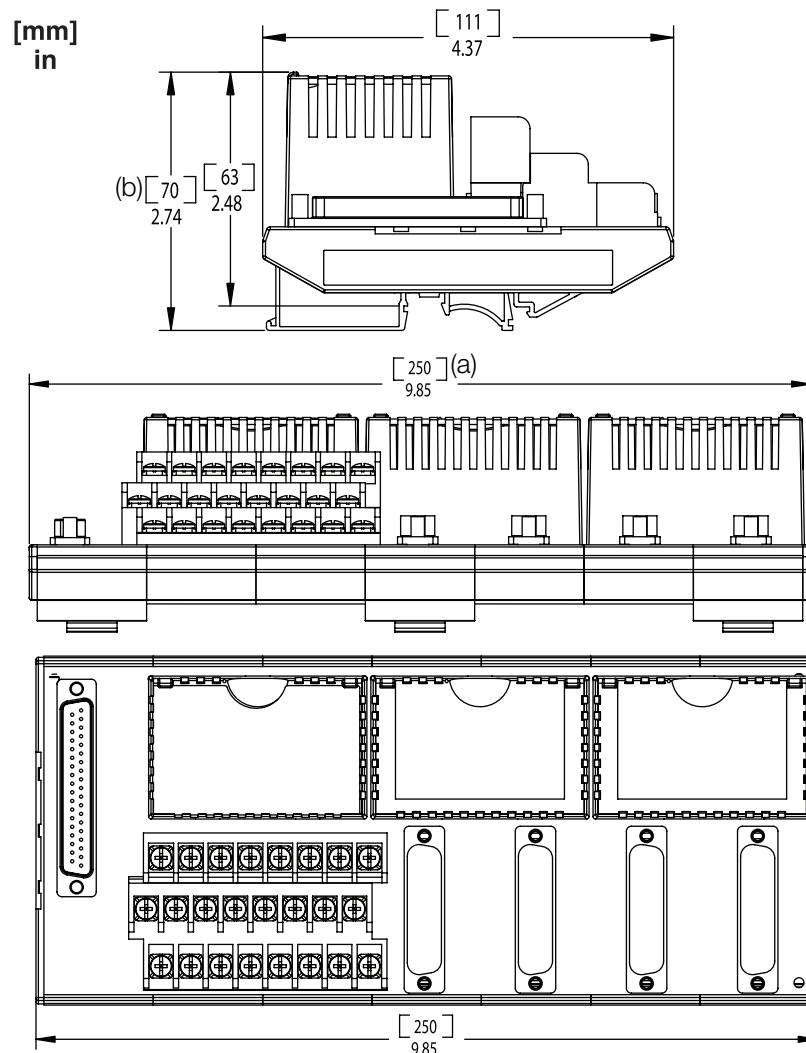

(a) Overall width – for determining DIN rail loading.
 (b) Height above DIN rail (add to DIN rail height for total).



33 Commercial Street
 Foxboro, MA 02035-2099
 United States of America
 www.foxboro.com
 Inside U.S.: 1-866-746-6477
 Outside U.S.: 1-508-549-2424
 or contact your local Foxboro
 representative.
 Facsimile: 1-508-549-4999

Invensys, FoxCAE, Foxboro, and I/A Series are trademarks of Invensys plc, its subsidiaries, and affiliates. All other brand names may be trademarks of their respective owners.

Copyright 2000-2006 Invensys Systems, Inc.
 All rights reserved

MB 021

Printed in U.S.A.

0706