

## I/A Series® Hardware

PSS 21H-2Z5 B4

## FBM205, 0 to 20 mA I/O Interface Module (Redundant)



The FBM205, 0 to 20 mA I/O Interface contains four redundant 0 to 20 mA dc analog input channels and four redundant 0 to 20 mA dc analog output channels.

**FEATURES**

Key features of the FBM205 are:

- ▶ Four redundant 20 mA dc analog input channels
- ▶ Four redundant 20 mA dc analog output channels
- ▶ Each input and output channel is galvanically isolated
- ▶ Compact, rugged design suitable for enclosure in Class G3 (harsh) environments
- ▶ Execution of an analog input application program that provides conversion time and configurable options for Rate of Change Limits
- ▶ Configurable options in the modules for output security include Fail-Safe Action
- ▶ High accuracy achieved by sigma-delta data conversions for each channel
- ▶ Termination Assemblies (TAs) for locally or remotely connecting field wiring to the FBM205
- ▶ Redundant loop power on FBM powered transmitters
- ▶ 3-tier termination assembly for per channel internally and/or externally loop powered transmitters.

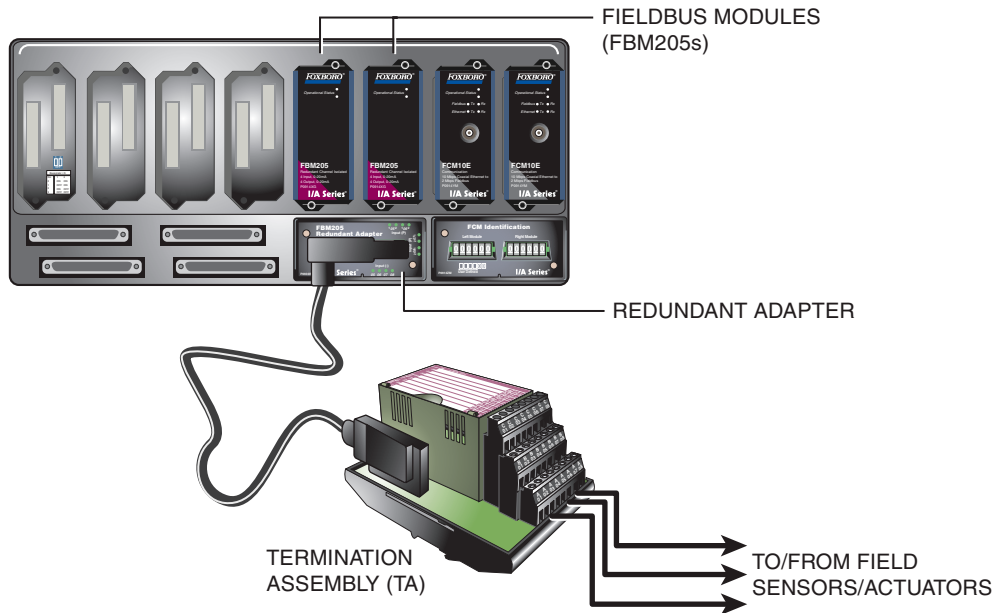

Figure 1. Redundant I/O Configuration

## INTRODUCTION

The FBM205, 0 to 20 mA I/O Interface (Redundant) contains four redundant 0 to 20 mA dc analog input channels and four redundant 0 to 20 mA dc analog output channels. The inputs/outputs are galvanically isolated from other channels and ground.

A redundant pair of the modules combine to provide redundancy at the Fieldbus Module (FBM) level, with field I/O wired to one common termination assembly (see Figure 1). Each module independently attempts to hold the output(s) at its specified output value(s), and each independently reports its observed value of the inputs.

A redundant analog input and redundant analog output block in the control software validates each input and output in conjunction with information to/from the module.

## REDUNDANT ANALOG INPUTS/OUTPUTS

A redundant analog output function block, AOATR, is used for each redundant pair of outputs. The AOATR block handles output writes and initialization logic for the redundant channels. On each execution cycle of the AOATR block, identical output writes are sent to both modules, fully exercising the fieldbus and the logic circuitry of each module. When a failure is detected in one of the modules, its output is driven to 0 mA and the corresponding channel in the good module automatically continues supplying the proper current to the output current loop.

A redundant analog input function block, AINR, is used for each redundant pair of inputs. The AINR block handles input reads and initialization logic for the redundant channels. On each execution cycle of the AINR block, identical reads are sent to both modules, fully exercising the fieldbus and the logic circuitry of each module.

Each input channel accepts an analog sensor input such as a 4 to 20 mA transmitter or a self-powered 4 to 20 mA source. Each output channel drives an external load and produces a 0 to 20 mA output. Transmitter power from each module is diode OR'd together in the redundant adapter to ensure redundant power. The microprocessor of each module executes the analog I/O application program, plus security routines that validate the health of the FBM.

Input channel options include a configurable choice of integration time on a per module basis. Input channel security is enhanced by redundantly powering the input current loop from per channel power supplies in each module of the pair.

Configurable options in the modules for output security include Fail-Safe Action (Hold/Fallback), Analog Output Fail-Safe Fallback Data (on a per channel basis), Fieldbus Fail-Safe Enable, and Fieldbus Fail-Safe Delay Time. The Analog Output Fail-Safe Fallback Data option must be set for 0 mA output. This removes one of the pair of redundant output channels from service for detectable problems such as a module not properly receiving output writes or not passing security tests on FBM microprocessor writes to output registers. Setting of the Analog Output Fail-Safe Fallback Data option for 0 mA output also minimizes the possibility of a “fail high” result.

### **HIGH ACCURACY**

For high accuracy, the module incorporates sigma-delta converters for each channel, which provides new analog input readings every 25 ms, and a configurable integration period to remove any process noise and power line frequencies. Each time period, the FBM converts each analog input to a digital value, averages these values over the time period and provides the averaged value to the controller.

### **HIGH RELIABILITY**

The redundancy of the module pair, coupled with the high coverage of faults, provides a very high subsystem availability time.

The Redundant Adapter provides test points that can be used for periodic test and measurement of the output voltage of each transmitter power supply. Such periodic testing can increase the statistical availability of the module.

### **COMPACT DESIGN**

FBM205 has a compact design, with a rugged extruded aluminum exterior for physical protection of the circuits. Enclosures specially designed for mounting the FBMs provide various levels of environmental protection, up to harsh environments, per ISA Standard S71.04.

### **VISUAL INDICATORS**

Light-emitting diodes (LEDs) incorporated into the front of the module provide visual status indications of Fieldbus Module functions.

### **EASY REMOVAL/REPLACEMENT**

Either module may be replaced without upsetting field input or output signals to the good module. The module can be removed/replaced without removing field device termination cabling, power, or communications cabling.

### **FIELDBUS COMMUNICATION**

A Fieldbus Communications Module or a Control Processor interfaces to the redundant 2 Mbps module Fieldbus used by the FBMs. The FBM205 accepts communication from either path (A or B) of the 2 Mbps Fieldbus — should one path fail or be switched at the system level, the module continues communication over the active path.

## **MODULAR BASEPLATE MOUNTING**

The module mounts on a DIN rail mounted Modular baseplate, which accommodates up to four or eight fieldbus modules. The Modular baseplate is either DIN rail mounted or rack mounted, and includes signal connectors for redundant fieldbus, redundant independent dc power, and termination cables.

Redundant modules must be located in adjacent positions on the baseplate (positions 1 and 2, 3 and 4, 5 and 6, or 7 and 8). To achieve the redundancy, a redundant adapter module is placed on the two adjacent baseplate termination cable connectors to provide a single termination cable connection (see Figure 1). A single termination cable connects from the redundant adapter to the associated termination assembly (TA).

## **FUNCTIONAL SPECIFICATIONS**

### **Input/Output Channels**

Four 0 to 20 mA dc analog input channels and four 0 to 20 mA dc analog output channels. Each channel is isolated and independent.

#### **NOTE**

Redundant pairs (input or output) are connected together by a common field I/O connector and therefore are not isolated from each other.

### **Input/Output Range (Each Channel)**

0 to 20.4 mA dc

### **Input Channels (4)**

#### **ANALOG ACCURACY (INCLUDES LINEARITY)**

±0.3% of span (Includes tolerance of sense resistor in redundant adapter).

Accuracy temperature coefficient: ±50 ppm/°C

#### **INPUT CHANNEL IMPEDANCE**

60 Ω nominal (resistor in redundant adapter)

#### **INPUT SIGNAL A/D CONVERSION**

Each channel performs its own A/D signal conversion, using the sigma-delta conversion technique.

#### **INTEGRATION PERIOD**

Software configurable

#### **COMMON MODE REJECTION**

>100 db at 50 or 60 Hz

#### **NORMAL MODE REJECTION**

>95 db at 50 or 60 Hz

### **FIELD DEVICE CABLING DISTANCE**

Maximum distance of the field device from the FBM is a function of compliance voltage (22.8 V dc), wire resistance, and voltage drop at the field device.

### **LOOP POWER SUPPLY PROTECTION**

Each channel is channel-to-channel galvanically isolated, current limited, and voltage regulated. All analog inputs are limited by their design to less than 30 mA. If the current limit circuit shorts out, the current is limited to about 100mA.

### **Output Channels (4)**

#### **ANALOG ACCURACY**

±0.05% of span

#### **OUTPUT LOAD**

750 Ω maximum

#### **OUTPUT PROCESSING DELAY**

30 ms maximum

#### **RESOLUTION**

13 bits

### **FIELD DEVICE CABLING DISTANCE**

Maximum distance of the field device from the FBM is a function of compliance voltage (19.6 V dc at 20.4 mA), wire resistance, and voltage drop at the field device.

### **LOOP POWER SUPPLY PROTECTION**

Each channel is channel-to-channel galvanically isolated, current limited, and voltage regulated. All analog outputs are limited by their design to about 25 mA. If the output FET shorts, the output current could increase up to 35 mA. In normal operation the FBM outputs a constant current into a 0 to 750 ohm load.

## FUNCTIONAL SPECIFICATIONS (CONTINUED)

### HART® PROTOCOL COMPATIBILITY

The channels meet the impedance requirements for a HART High Impedance Device and can be used in a HART loop without interfering with the HART signals between the field device and a Hand-Held Communicator (HHC).

If a FoxCom of HART transmitter is used with FBM205, a 200 ohm in-line resistor (assembly part number P0902VY) must be added in series with the transmitter.

### Input/Output Channel Isolation

Each channel is galvanically isolated from all other channels and earth (ground). The module withstands, without damage, a potential of 600 V ac applied for one minute between any channel and ground, or between a given channel and any other channel.

### CAUTION

This does not imply that these channels are intended for permanent connection to voltages of these levels. Exceeding the limits for input voltages, as stated elsewhere in this specification, violates electrical safety codes and may expose users to electric shock.

### Communication

Communicates with its associated FCM or FCP via the redundant 2Mbps module fieldbus.

### Power Requirements

#### INPUT VOLTAGE RANGE (REDUNDANT)

24 V dc +5%, -10%

#### CONSUMPTION

10 W (maximum) total for redundant pair

#### HEAT DISSIPATION

7 W (maximum) total for redundant pair

#### LOOP POWER SUPPLY PROTECTION

Each channel is channel-to-channel galvanically isolated, current limited, and voltage regulated.

### Calibration Requirements

Calibration of the module and termination assembly is not required.

### Regulatory Compliance

#### ELECTROMAGNETIC COMPATIBILITY (EMC)

##### *European EMC Directive 89/336/EEC*

Meets: EN 50081-2 Emission standard

EN 50082-2 Immunity standard

EN 61326 Annex A (Industrial Levels)

##### *CISPR 11, Industrial Scientific and*

##### *Medical (ISM) Radio-frequency*

##### *Equipment - Electromagnetic Disturbance Characteristics - Limits and Methods of Measurement*

Meets: Class A Limits

##### *IEC 61000-4-2 ESD Immunity*

Contact 4 kV, air 8 kV

##### *IEC 61000-4-3 Radiated Field Immunity*

10 V/m at 80 to 1000 MHz

##### *IEC 61000-4-4 Electrical Fast*

##### *Transient/Burst Immunity*

2 kV on I/O, V dc power and communication lines

##### *IEC 61000-4-5 Surge Immunity*

2 kV on I/O, V dc power and communication lines

##### *IEC 61000-4-6 Immunity to Conducted*

##### *Disturbances induced by Radio-frequency Fields*

10 V (rms) at 150 kHz to 80 MHz on I/O, V dc power and communication lines

##### *IEC 61000-4-8 Power Frequency*

##### *Magnetic Field Immunity*

30 A/m at 50 and 60 Hz

## FUNCTIONAL SPECIFICATIONS (CONTINUED)

### PRODUCT SAFETY

#### ***Underwriters Laboratories (UL) for U.S. and Canada***

UL/UL-C listed as suitable for use in UL/UL-C listed Class I, Groups A-D; Division 2; temperature code T4 enclosure based systems. These modules are also UL and UL-C listed as associated apparatus for supplying non-incendive communication circuits for Class I, Groups A-D hazardous locations when connected to specified I/A Series® processor modules as described in the *I/A Series DIN Rail Mounted Subsystem User's Guide* (B0400FA). Communications circuits also meet the requirements for Class 2 as defined in Article 725 of the National Electrical Code (NFPA No.70) and Section 16 of the Canadian Electrical Code (CSA C22.1). Conditions for use are as specified in the *I/A Series DIN Rail Mounted Subsystem User's Guide* (B0400FA).

#### ***European Low Voltage Directive 73/23/EEC and Explosive Atmospheres (ATEX) directive 94/9/EC***

CENELEC (DEMKO) certified as EEx nA IIC T4 for use in CENELEC certified Zone 2 enclosure certified as associated apparatus for supplying non-incendive field circuits for Zone 2, Group IIC, potentially explosive atmospheres when connected to specified I/A Series processor modules as described in the *I/A Series DIN Rail Mounted Subsystem User's Guide* (B0400FA). Also see, "Certification for Termination Assemblies" on page 10.

#### **NOTE**

CENELEC (DEMKO) Certification does not apply to Termination Assembly P0917QW. See Types 4 and 5 on Table 1 on page 10.

## ENVIRONMENTAL SPECIFICATIONS<sup>(1)</sup>

### Operating

#### TEMPERATURE

##### *Module*

-20 to +70°C (-4 to +158°F)

##### *Termination Assembly*

##### **PVC**

-20 to +50°C (-4 to +122°F)

##### **PA**

-20 to +70°C (-4 to +158°F)

#### RELATIVE HUMIDITY

5 to 95% (noncondensing)

#### ALTITUDE

-300 to +3,000 m (-1,000 to +10,000 ft)

### Storage

#### TEMPERATURE

-40 to +70°C (-40 to +158°F)

#### RELATIVE HUMIDITY

5 to 95% (noncondensing)

#### ALTITUDE

-300 to +12,000 m (-1,000 to +40,000 ft)

### Contamination

Suitable for use in Class G3 (Harsh) environments as defined in ISA Standard S71.04, based on exposure testing according to EIA Standard 364-65, Class III.

### Vibration

0.75 m/S<sup>2</sup> (5 to 500 Hz)

---

(1) The environmental limits of this module may be enhanced by the type of enclosure containing the module. [Refer to the applicable Specification Sheet (PSS) which describes the specific type of enclosure that is to be used.]

## PHYSICAL SPECIFICATIONS

### Mounting

#### MODULE

FBM205 mounts on a baseplate. The baseplate can be mounted on a DIN rail (horizontally or vertically), or horizontally on a 19-inch rack using a mounting kit. Redundant modules must be located in adjacent positions on the baseplate (positions 1 and 2, 3 and 4, 5 and 6, or 7 and 8). Refer to PSS 21H-2W6 B4 for details regarding baseplate usage.

#### TERMINATION ASSEMBLY

The TA mounts on a DIN rail and accommodates multiple DIN rail styles including 32 mm (1.26 in) and 35 mm 1.38 in)

### Mass

#### MODULE

284 g (10 oz) approximate

#### TERMINATION ASSEMBLIES

##### *Compression*

159 g (0.35 lb, approximate)

##### *Ring Lug*

204 g (0.45 lb, approximate)

### Dimensions - Module

#### HEIGHT

102 mm (4 in), 114 mm (4.5 in) including mounting lugs

#### WIDTH

45 mm (1.75 in)

#### DEPTH

104 mm (4.11 in)

### Dimensions - Termination Assemblies

Refer to page 11

### Part Numbers

#### FBM205 MODULE

P0914XG

#### TERMINATION ASSEMBLIES

See "FUNCTIONAL SPECIFICATIONS - TERMINATION ASSEMBLIES" on page 9

#### REDUNDANT ADAPTER

P0916NN

### Termination Cables

#### CABLE LENGTHS

Up to 30 m (98 ft)

#### CABLE MATERIALS

Polyurethane or Hypalon®/XLP

#### TERMINATION CABLE TYPE

Type 1 - Refer to Table 2

#### CABLE CONNECTION

25-pin male D-subminiature

### Construction - Termination Assembly

#### MATERIAL

Polypropylene (PVC), compression

PVC, ring lug

Polyamide (PA), compression

PA, ring lug

#### FAMILY GROUP COLOR

Raspberry red - analog

#### TERMINAL BLOCKS

Inputs - 3 tiers, 4 positions

Outputs - 3 tiers, 4 positions

Output Bypass Jacks - 4 (P0917QW)

### Field Termination Connections

#### COMPRESSION - ACCEPTED WIRING SIZES

##### *Solid/Stranded/AWG*

0.2 to 4 mm<sup>2</sup>/0.2 to 2.5 mm<sup>2</sup>/24 to 12 AWG

##### *Stranded with Ferrules*

0.2 to 2.5 mm<sup>2</sup> with or without plastic collar

#### RING-LUG - ACCEPTED WIRING SIZES

#6 size connectors (0.375 in (9.5 mm))

0.5 to 4 mm<sup>2</sup>/22 AWG to 12 AWG

## TERMINATION ASSEMBLIES AND CABLES

Field I/O signals connect to the FBM subsystem via DIN rail mounted termination assemblies, which are electrically passive. TAs for the FBM205 module are available in the following forms:

- ▶ Compression screw type using Polyvinyl Chloride (PVC) material or Polyamide (PA) material
- ▶ Ring lug type using Polyvinyl Chloride (PVC) or Polyamide (PA) material.

Each FBM205 Termination Assembly and its associated termination cable provide feedthrough connection between four 2-wire analog input signals and four 2-wire analog output signals, and the FBM205 Redundant 0 to 20 mA I/O Interface Module.

When used in a redundant FBM205 configuration, a redundant adapter (P016NN) is required for connection between the FBM baseplate and the termination cable.

Termination Assembly (P0917QW) includes built-in bypass jacks for each output channel. Jacks accept a bypass plug from the I/A Series Output Bypass Station (Foxboro P/N P0900HJ) or other external 20 mA sources. This option should be considered for applications where maintaining output during maintenance operations is desired.

A removable termination cable connects the DIN rail mounted TA to the FBM via a field connector on the baseplate in which the FBM is installed. Termination cables are available in the following materials:

- ▶ Polyurethane
- ▶ Hypalon XLP.

Termination cables are available in a variety of lengths, up to 30 meters (98 feet), allowing the termination assembly to be mounted in either the enclosure or in an adjacent enclosure. See Table 2 for a list of termination cables used with the TAs for the FBM205 module.

## FUNCTIONAL SPECIFICATIONS - TERMINATION ASSEMBLIES

FBM Type	Input		Output		TA Part No. (a)		Termination Type (b)	TA Cable Type (c)	TA Cert. Type (d)
	Qty	Signal	Qty.	Signal	PVC	PA			
FBM205	4	0 to 20 mA	4	0 to 20 mA	P0916AL P0916AK	P0916XL P0917JP	C RL	1	1, 2
FBM205	4	0 to 20 mA	4	0 to 20 mA	P0917QW		C	1	4,5

(a) PVC is polyvinyl chloride rated from -20 to +50°C (-4 to +122°F). PA is polyamide rated from -20 to +70°C (-4 to +158°F).

(b) C = TA with compression terminals; RL = TA with ring lug terminals.

(c) See Table 2 for cable part numbers and specifications.

(d) See Table 1 for Termination Assembly certification definitions.

**Table 1. Certification for Termination Assemblies**

Type	Certification
Type 1	TAs are UL/UL-C listed as suitable for use in Class I; Groups A-D; Division 2 temperature code T4 hazardous locations. They are CENELEC (DEMKO) certified EEx nA IIC T4 for use in Zone 2 potentially explosive atmospheres.
Type 2	TAs are UL/UL-C listed as associated apparatus for supplying non-incendive field circuits Class I; Groups A-D; Division 2 hazardous locations when connected to specified DIN rail mounted FBMs and field circuits meeting entity parameter constraints specified in <i>DIN Rail Mounted Subsystem User's Guide</i> (B0400FA). They are also CENELEC (DEMKO) certified as associated apparatus for supplying field circuits for Group IIC, Zone 2 potentially explosive atmospheres. Field circuits are also Class 2 limited energy (60 V dc, 30 V ac, 100 VA or less) if customer-supplied equipment meets Class 2 limits.
Type 4	All field circuits are Class 2 limited energy (60 V dc, 30 V ac, 100 VA or less) if customer-supplied equipment meets Class 2 limits.
Type 5	The TA and its field circuitry are for use in only ordinary (non-hazardous) locations.

**Table 2. Cables Types and Part Numbers**

Cable Length m (ft)	Type 1 P/PVC (a)	Type 1 H/XLPE (b)	Cable Length m (ft)	Type 1 P/PVC (a)	Type 1 H/XLPE (b)
0.5 (1.6)	P0916DA	P0916VA	15.0 (49.2)	P0916DF	P0916VF
1.0 (3.2)	P0916DB	P0916VB	20.0 (65.6)	P0916DG	P0916VG
3.0 (9.8)	P0916DC	P0916VC	25.0 (82.0)	P0916DH	P0916VH
5.0 (16.4)	P0916DD	P0916VD	30.0 (98.4)	P0916DJ	P0916VJ
10.0 (32.8)	P0916DE	P0916VE			

(a) P/PVC is polyurethane outer jacket and semi-rigid PVC primary conductor insulation. Temperature range; -20 to +80°C (-4 to +176°F).

(b) H/XLPE is Hypalon outer jacket and XLPE (cross-linked polyethylene) primary conductor insulation. Temperature range; -40 to +90°C (-40 to +194°F).

**DIMENSIONS—NOMINAL**

$\frac{\text{mm}}{\text{in}}$

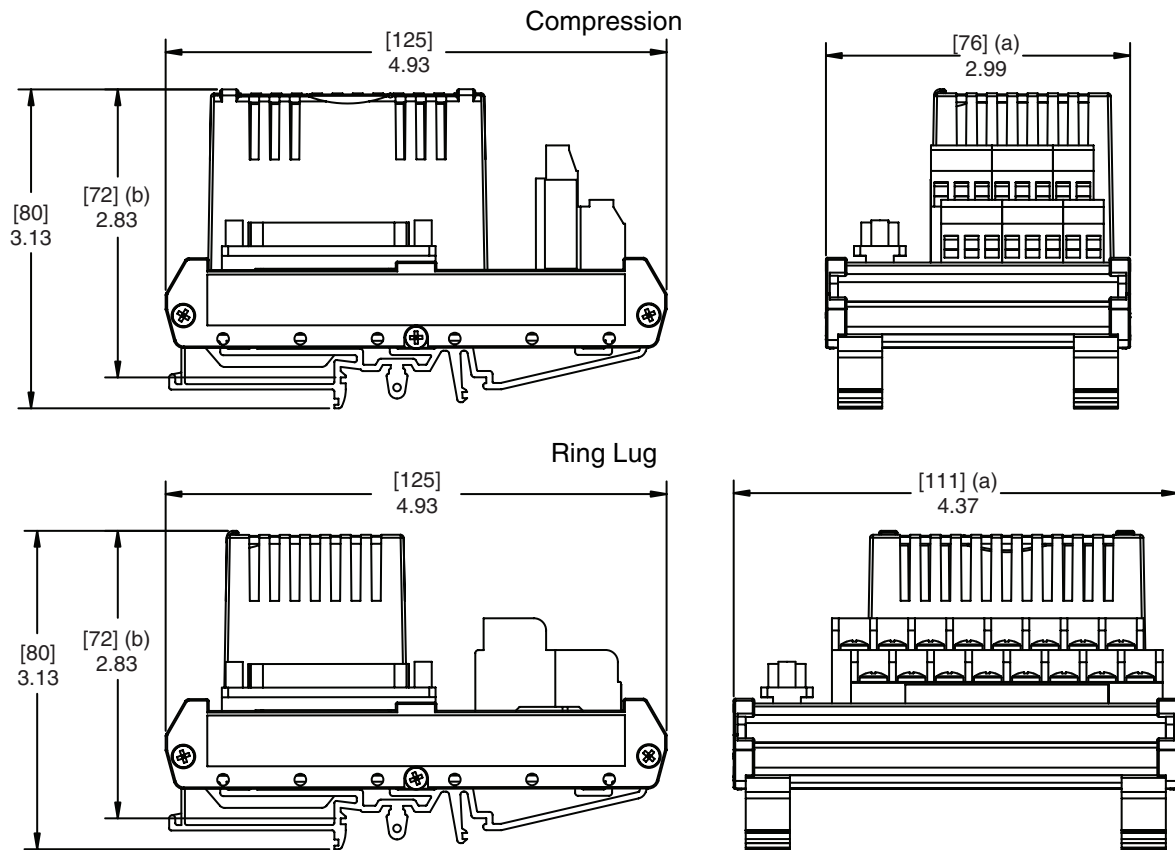

- (a) Overall width – for determining DIN rail loading.
- (b) Height above DIN rail (add to DIN rail height for total).

**RELATED PRODUCT SPECIFICATION SHEETS (PSS)**

<b>PSS Number</b>	<b>Description</b>
PSS 21H-2W1 B3	DIN Rail Mounted FBM Subsystem Overview
PSS 21H-2W2 B3	DIN Rail Mounted FBM Equipment, Agency Certification
PSS 21H-2S2 B4	Output Bypass Station (4 to 20 mA)



33 Commercial Street  
Foxboro, MA 02035-2099  
United States of America  
[www.foxboro.com](http://www.foxboro.com)  
Inside U.S.: 1-866-746-6477  
Outside U.S.: 1-508-549-2424  
or contact your local Foxboro  
representative.  
Facsimile: 1-508-549-4999

Invensys, Foxboro, and I/A Series are trademarks of Invensys plc, its subsidiaries, and affiliates.  
All other brand names may be trademarks of their respective owners.

Copyright 1999-2007 Invensys Systems, Inc.  
All rights reserved

MB 021

Printed in U.S.A.

0307