

CM50S Specification and Technical Data

CM03-541
Release 5.0
6/95

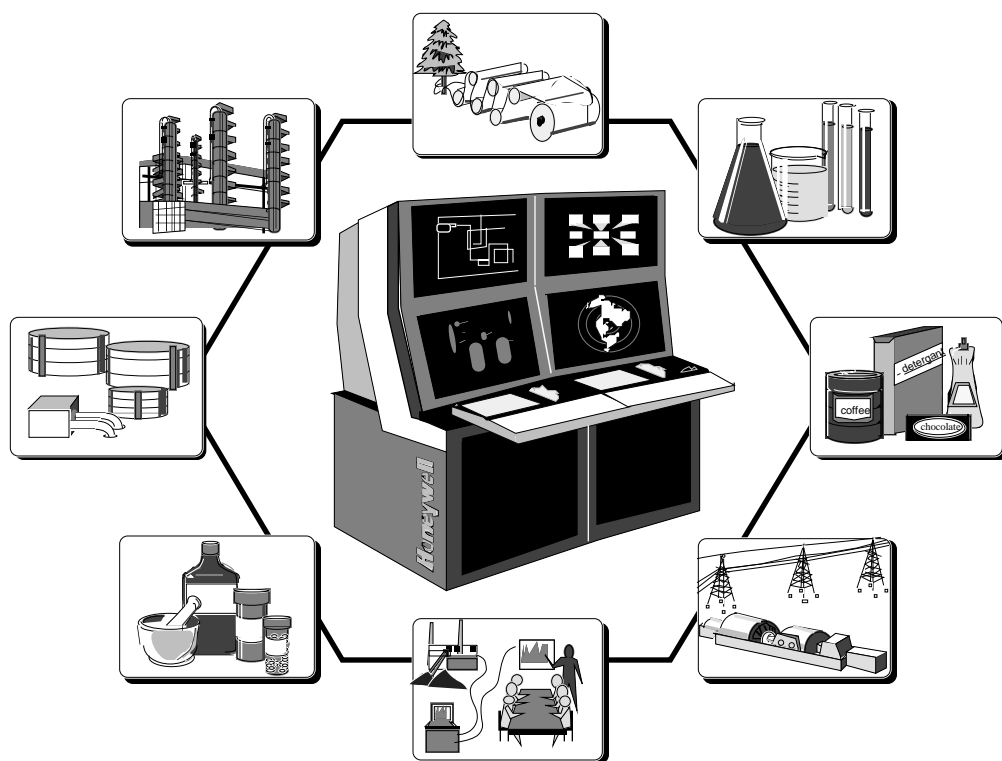

CM50S Release 5.0

Specification and Technical Data

Introduction

CM50S—Release 5.0 consists of a Honeywell software package that, along with associated hardware, enables a Digital Equipment Corporation OpenVMS system to function as a Computing Module of the TDC 3000^X Local Control Network as shown in Figure 1.

Accordingly, the Digital system Computing Module can exchange information with all other nodes on the LCN, and can serve as a data-gathering node

OpenVMS, AXP and VAX are trademarks of Digital Equipment Corporation.

within an overall plant-wide management information system.

One CM50S on a OpenVMS system can support up to four connections to Plant Network Modules and/or Computer Gateways. The Plant Network Modules and Computer Gateways may reside as nodes on the same or different LCNs. Figure 1 shows two CM50S packages connected to the same LCN, with each using one type of physical connection.

Note, CM50S Release 5.0 fully supports existing Computer Gateway installations. The Plant Network Module, however, replaces the Computer Gateway for all new installations.

An Ethernet network is the communications medium, if the Plant Network Module is used to interface the LCN to a Digital system.

Using the Plant Network Module, the CM50S package supports all Digital systems bus structures as well as busless Digital systems, such as VAXstation and Fault Tolerant VAX systems and AXP systems.

The Plant Network Module interface is through an Ethernet cable. The Digital system thus becomes a module on the LCN with the ability to communicate with other LCN modules and with process-connected devices on

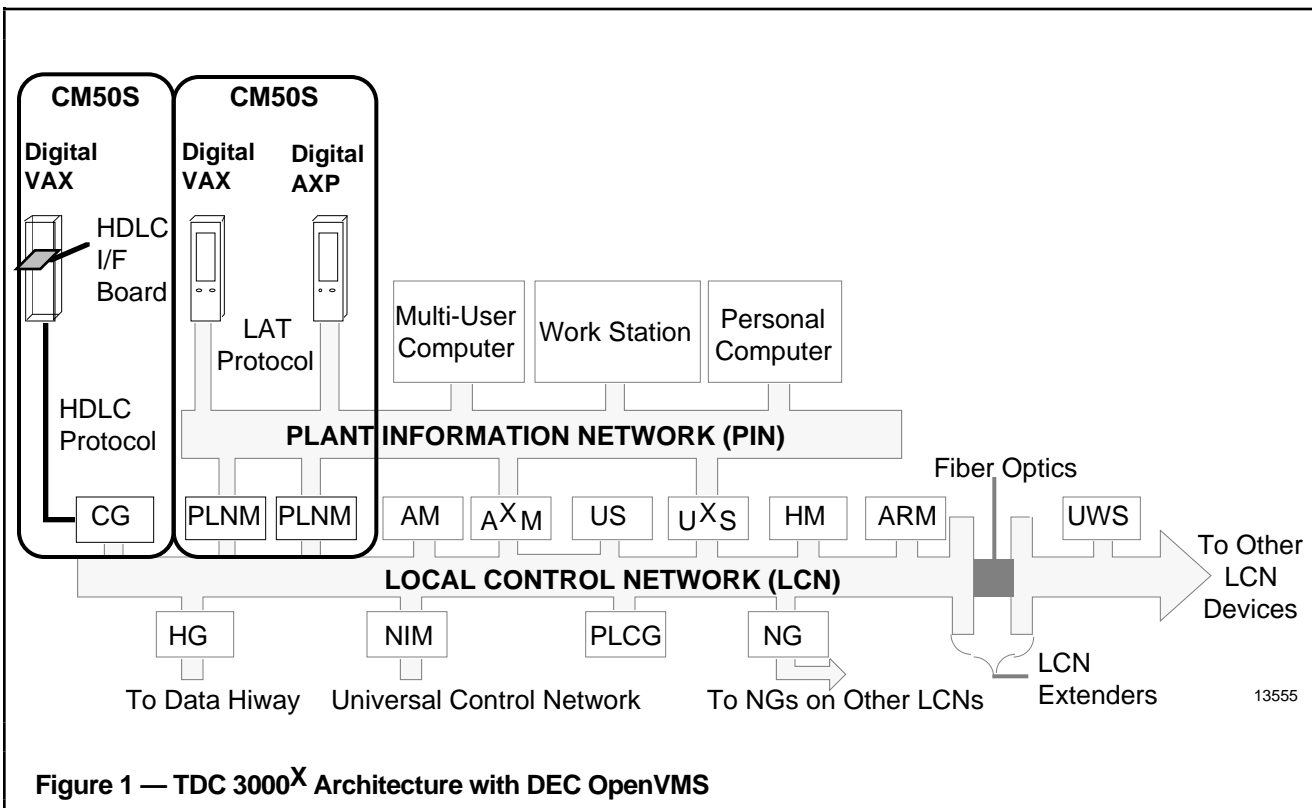

Figure 1 — TDC 3000^X Architecture with DEC OpenVMS

the UCN and Data Hiway. When the existing Computer Gateway is used for the hardware interface, a Honeywell-supplied board is inserted into a VAX system and an HDLC connection is used as the communications medium.

Using the CM50S, the OpenVMS application can access real-time or historical data residing in TDC 3000^X Modules on the LCN. This data can then be used by process management application packages that reside in the Digital system. Process attributes can be derived by modeling and simulation application packages to optimize the processes and more easily anticipate required process changes.

In addition, control parameters that establish setpoints can be returned directly to the LCN Application Modules and process-connected devices. Historical data is available for statistical quality and process control applications. Operator interfaces can be improved by sending interactive messages to the LCN Universal Station.

By using the OpenVMS data communications capabilities, it is also possible to exchange data with nonprocess systems such as laboratory systems, material and inventory control systems, and plant-wide information systems. In this way, the TDC 3000^X System can become a node in existing computer networks.

User-written application programs supported by CM50S execute within the environment provided by the OpenVMS operating system. These programs also use special interface routines that simplify the exchange of data with other TDC 3000^X nodes and boxes. These interface routines are compatible with the use of Fortran, Pascal, or "C"

DEC is a trademark of Digital Equipment Corporation.

Functions

- Provides a standard interface between the OpenVMS Computing Module and one to four TDC 3000^X LCNs.
- Collects data from other LCN nodes and stores data to other nodes on request from the OpenVMS applications.
- Collects continuous history data from the History Module.
- Holds a database that represents computer programs, plus other computer-prepared data.
- Provides for scheduling and/or operator/event demand of computer programs.
- Transmits messages to Universal Station operators.
- Receives messages from CL Programs, the Process Manager, and Multifunction Controller sequences.

programming languages.

Functional Description

Figure 2 shows the relationships of the Plant Network Module to the Digital system and LCN.

The Plant Network Module interfaces an OpenVMS computing module to one to four TDC 3000^X Systems.

The Digital system is expected to be used for management

information system, plant management data collection and advanced control at a higher level and wider scope than is possible with any other device. These tasks include both current values and historical data. Typically, computing module control strategies are implemented along with Process Manager and Application Module control strategies.

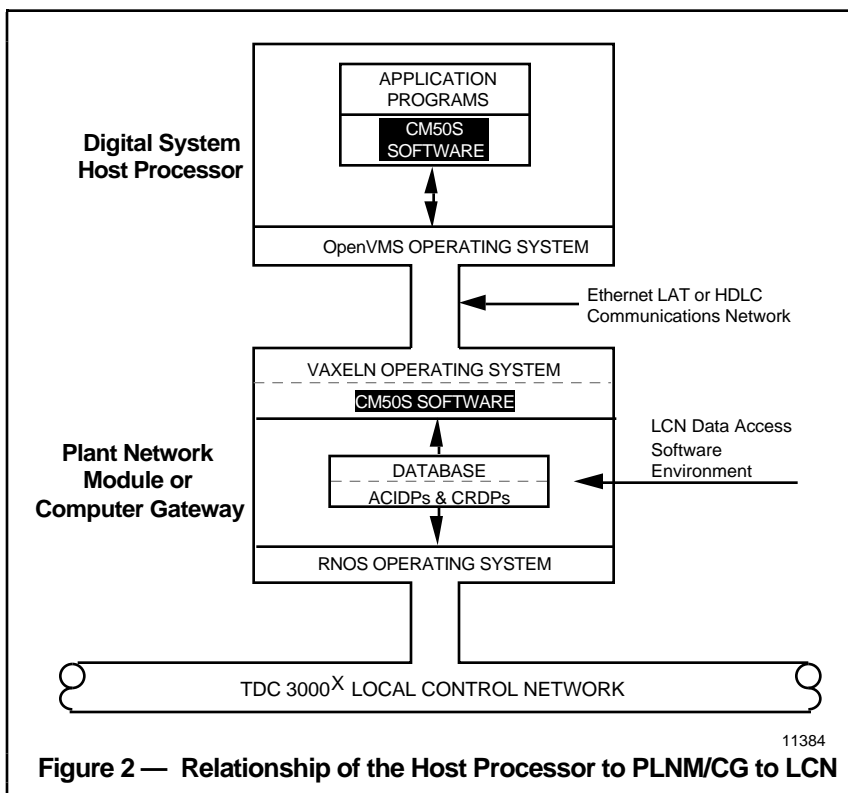

Figure 2 — Relationship of the Host Processor to PLNM/CG to LCN

Data Collection and Storage

Application programs can gain access to data throughout the TDC 3000^X System. This is accomplished through four major types of functions:

- Get Data
- Store Data
- Get History
- Get/Send Message

Data

For Get and Store-Data calls, the values are requested either by multi- or single-point/parameter names or in Data Definition Tables (DDT) that are defined and built by the user in the host computer. The tables contain ASCII data point and parameter names that will be fetched from and stored to the TDC 3000^X System.

The LCN data access software converts the external point names to internal identifiers that are used in actual data transfers. Real values are returned in engineering unit format. The status of data collected, as well as the status of the call, is also returned. Up to 300 parameters can be collected or stored using a single DDT or multi-point list.

Once built, these tables are typically stored in the host computer. For Get-Data calls, however, they can be made resident in the Plant Network Module. The Plant Network Module also supports the accessing of Custom Data Segment arrays using a single call.

Storing data is handled in a similar manner to collecting data: either multi- or single-point, whole arrays, or data definition tables can be used. There are several levels of security provided to assure proper access control for writing data to the Local Control Network and its associated UCNs or Data Hiways. Writes can be prevented at the CM50S, the

process device, UCN/Hiway, and program level.

Program Security

Through security mechanisms, users can be denied the ability to perform CM50S functions, including writing to the LCN.

To provide this security, a CM50S Manager user account is established under OpenVMS. The manager has full-privileged access to all CM50S functions, including the granting of CM50S usage permissions to other end users.

File Transfer

Files from History Modules can be read into the OpenVMS system, and downloaded back to the same or different History Module. ASCII type files from the LCN can be edited on the OpenVMS system before they are written back to the LCN. The Engineering Personality File Management commands (Copy, Rename, Delete, List Volumes, List Catalogs, List File Attributes and Create/Delete Directory) can also be invoked from the OpenVMS system. LCN Journals can also be extracted into open VMS files.

History

Continuous history data from History Modules can be obtained by OpenVMS application programs. This includes not only PV values, but other real parameters selected for historization by the History Module. Both snapshots and averages can be accessed. Historical data for up to 24 parameters can be obtained in a single call. History can be accessed in relative or absolute time. Min/max data is also available.

Messages

Application programs can send messages to the Universal

Station operator by way of CM50S calls. Such messages optionally may require confirmation by the operator. This allows the application programs to request an action and to be suspended until a confirmation is received from the operator that the requested action has been completed.

Other devices on the LCN can send character-string messages to individual application programs in the computer. These messages are received by the Plant Network Module and held, pending a transfer request by the application program.

Gateway Database

Visibility of computer operation at the Universal Station is provided by a Plant Network Module database. CM50S users can view the configuration and status data, and the names of the points in the PLNM. The database can also be accessed by using the data-collection and storage facilities described above. This database consists of the following types of information:

- Advanced Control Interface Data Points (ACIDPs)
- Calculated Results Data Points (CRDPs)

Both of these can have optional custom data segments that hold data that is associated with application programs. For example, the results calculated by an optimization program can be stored in a data point's custom data segment. The results are then available to the operator at a Universal Station, for historization in the History Module, for calculations by the Application Module, etc. In addition, each ACIDP is associated with an application program and represents that program's status to the Local Control Network. Each ACIDP also contains security information about its associated program, which allows the program's access to

TDC 3000^X data to be restricted; for example, to read only. Up to 250 ACIDPs and up to 500 CRDPs can reside in a Plant Network Module. Each point can accommodate up to 10 custom data segments, each segment can contain 250 parameters, and each parameter can consist of a 1000-element array (assuming adequate memory is available).

Scheduling Application Programs

A CM50S-supplied, OpenVMS Task Scheduler can be used to schedule the execution of background tasks without operator intervention. These tasks are scheduled cyclically on the basis of time, date, and day of week.

Advanced Control Programs (ACPs) resident in the host computer can also be scheduled to run from a Plant Network Module. The scheduling can be cyclic or periodic and is based upon the LCN clock. ACPs can also be activated as a result of a Universal Station operator demand or an event on the TDC 3000^X LCN.

Program delays up to 60 seconds can be requested by an ACP.

An ACP can be terminated either normally or from an OpenVMS-induced error termination. When the ACP abnormally terminates, the Real-Time Journal receives an abort alarm.

Performance Measurements

Benchmark programs have been run on this CM50S software. These programs are used in the development of each release, and form a model for the expected field performance.

The benchmark programs are run on a specific platform and the information is extrapolated to

develop a generic performance model. The benchmark tests show a base level of performance.

The Performance Benchmark Platform

CM50S Release 5.0 was installed on a VAX 8250 running VMS 5.5.1. The 8250 is a VAXBI bus machine rated at 1.2 VUPS and has a DEBNA ethernet controller. The 8250 was dedicated to the execution of the benchmark programs and CM50S.

CM50S – AXP Release 5.0 was installed on a DEC AXP 3000/400 with 64MB of memory. The 3000/400 was dedicated to the execution of the benchmark programs and CM50S.

The LCN was running Release 321 with the following equipment:

- 1 History Module
- 1 Application Module
- 1 Computer Gateway or Plant Network Module
- 1 Hiway Gateway
- 1 Multifunction Controller
- 3 Universal Stations all running in Universal Personality

The LCN was dedicated to the execution of the benchmark programs. All tests were run with one link to a Computer Gateway or Plant Network Module. A single ACIDP was used for testing writes.

The Performance Benchmark Programs

Each program is designed to repetitively execute a specific CM50S function. The time required to complete each execution is recorded and the average time is graphed to show the number of transactions per second, and the parameters per second that each function can achieve. By executing the same program under different process IDs, a measurement of the multi-threaded throughput for the CM50S function can also be

obtained. Transactions per second and parameters per second act together as limiting performance factors. For example, while it is true that a program can obtain 200 parameters per second, it cannot do this by requesting 1 point per call executed 200 times.

The following abbreviations are used in the performance tables.

- NVT** No Value Table processing
- VT** Value Table processing
- NCG** Not a CG or PLNM Resident DDT
- CG** or **PLNM** means the DDT is CG or PLNM resident to maximize performance by minimizing the transaction overhead
- NTP** No Table Processing
- TP** Specifies the CM50S function that performs Table Processing on the returned values.

DDT Read

Table 1 shows the results of the benchmark programs executing the CM50_DDT_GET and the CM50_DDT_GETNT calls using the Plant Network Module or Computer Gateway.

The DDTs consist entirely of REAL point.parameters that reside on the Application Module.

Notice that the Transactions Per Second numbers are not linear. There is a certain amount of overhead for each execution of the function regardless of the amount of data requested. This overhead becomes significant when simultaneous access through the Computer Gateway or Plant Network Module is attempted. CM50S Release 5.0 performance of the Computer Gateway and Plant Network Module are fairly close, although the PLNM has an advantage for larger data transfers.

Simultaneous DDT Read Processes

Table 2 displays the results of the benchmark programs executing the CM50_GET_PTID call using the Plant Network Module and the Computer Gateway with seven programs executing simultaneously.

In the test, each ACP executed the call 20 times. The averages are shown in the table. The data was an array of 1000 real values. The ACP requested the whole array and the values were AM resident.

Initially, one ACP performed the specified test and then waited on an event flag. A master process then added another ACP which would wait on the same event flag. The master process then signaled the event flag ensuring that the ACPs execute simultaneously.

Table 1 — DDT Read Single Point from AM

Plant Network Module or Computer Gateway Executing CM50_DDT_GET								
Parameters Per DDT	NVT/NCG/NTP				VT/NCG/TP			
	Transactions Per Sec.		Parameters Per Sec.		Transactions Per Sec.		Parameters Per Sec.	
	VAX	AXP	VAX	AXP	VAX	AXP	VAX	AXP
1	1.67	3.09	1.67	3.08	0.71	2.07	0.71	2.06
100	1.18	2.00	118	199	0.47	1.66	47.25	166
200	1.00	1.34	200	268	0.52	1.25	104.78	250
300	0.75	1.11	225	333	0.45	0.96	136.21	288

Plant Network Module or Computer Gateway Executing CM50_DDT_GETNT								
Parameters Per DDT	NVT/NCG/NTP				VT/NCG/TP			
	Transactions Per Sec.		Parameters Per Sec.		Transactions Per Sec.		Parameters Per Sec.	
	VAX	AXP	VAX	AXP	VAX	AXP	VAX	AXP
1	3.43	4.85	3.43	4.85	0.87	2.52	0.87	2.52
100	2.02	2.71	202	271	0.77	2.49	77	249
200	1.67	1.85	334	396	0.71	1.72	143	340
300	1.35	1.59	405	477	0.66	1.39	199	418

Table 2 — Concurrent ACPs Performing DDT Reads of AM Data

Plant Network Module Executing CM50_GET_PTID				
Number of ACPs	Transactions Per Sec.		Parameters Per Sec.	
	VAX	AXP	VAX	AXP
1	1.3	2.86	406	1426
2	1.99	5.71	596	2857
3	2.66	6.26	796	3129
4	2.93	6.34	880	3168
5	3.22	6.32	967	3162
6	3.41	6.32	1022	3157
7	3.51	6.32	1074	3158

Computer Gateway Executing CM50_GET_PTID		
Number of ACPs	Transactions Per Second	Parameters Per Second
1	1.20	359.93
2	1.99	597.28
3	2.01	603.81
4	2.03	608.17
5	2.03	607.89
6	2.03	609.98
7	2.03	609.82

Clearly, after the third or fourth ACP, there is little variation in the Parameters Per Second; however, the Transactions Per Second continues to rise. This shows that, as more ACPs are executed simultaneously, the longer each will take to complete its task. It is recommended that scheduled ACPs be staggered, if possible, to avoid such bottlenecks.

Table 2 also illustrates the advantage the PLNM has in transferring large data requests. Attempting to execute a number of ACPs on a 1 minute cycle can also lead to problems if the system is not designed using both limiting factors. The problem is that an ACP is still executing when the next scheduled trigger arrives, and is thus discarded.

DDT Store

Table 3 displays the results of the benchmark programs executing the CM50_DDT_STORE and the CM50_DDT_STORENT calls using the Plant Network Module or Computer Gateway.

List Array Access

Table 4 displays the results of the benchmark programs executing the CM50_GET_REALNBR call using the Plant Network Module and the Computer Gateway. The List Array Access (LAX) function is very important to users of ABE, PMO, and PDE, as this is the CM50 call being used to retrieve the data.

Table 3 — DDT Stores AM Data

Plant Network Module or Computer Gateway Executing CM50_DDT_STORE and CM50_DDT_STORENT									
Parameters Per DDT	NVT/NCG/NTP				VT/NCG/TP				
	Transactions Per Sec.		Parameters Per Sec.		Transactions Per Sec.		Parameters Per Sec.		
	VAX	AXP	VAX	AXP	VAX	AXP	VAX	AXP	AXP
1	1.66	4.43	1.66	4.43	0.46	2.02	0.46	2.02	
100	1.00	100	100	100	0.39	0.72	39.13	72	
200	0.71	0.71	140	142	0.33	0.46	66.42	92	
300	0.56	0.50	167	189	0.31	0.35	91.64	104	

Table 4 — List Array Access Call of AM Data

Plant Network Module Executing CM50_GET_REALNBR				
Parameters Per DDT	Transactions Per Sec.		Parameters Per Sec.	
	VAX	AXP	VAX	AXP
1	3.36	2.76	3.36	2.75
100	1.62	2.01	162	200
200	1.19	1.61	238	321
300	0.89	1.11	265	331
Computer Gateway Executing CM50_GET_REALNBR				
Parameters Per DDT	Transactions Per Second		Parameters Per Second	
1	2.01		2.01	
100	1.23		122.70	
200	0.88		175.06	
300	0.64		192.15	

This function sends a precompiled DDT to the PLNM or Computer Gateway for processing the data request. This optimization makes the List Array Access function second only to PLNM-resident DDTs for performance.

This is another type of CM50S call that shows the advantage of the Plant Network Module over the Computer Gateway.

Table 5 - LCN File Transfer Performance

Plant Network Module or Computer Gateway Executing SAVE and RESTORE LCN FILE for file back-up		
File Type	Function	Sectors/Second*
Continuous	Save	29.9
	Restore	27.3
Linked-Fixed	Save	30.9
	Restore	29.9
Linked-Variable	Save	21.4
	Restore	19.0

CM50S Executing READ or WRITE LCN FILE for file editing		
File Type	Function	Sectors/Second*
Continuous	Read	18.4
	Write	24.6
Linked-Fixed	Read	31.7
	Write	29.9
Linked-Variable	Read	26.2
	Write	15.5

* Values are History Module sectors per second (1 sector equals 256 bytes).

LCN File Transfer

The File Transfer benchmarks were run with a single link between CM50S and a Plant Network Module. The time values used in the table were obtained by averaging the times of large, medium, and small sized files for each of the three types. The actual values may vary depending on the sizes of files being transferred.

While this information is presented in good faith and believed to be accurate, Honeywell disclaims the implied warranties of merchantability and fitness for a particular purpose and makes no express warranties except as may be stated in its written agreement with and for its customer.

In no event is Honeywell liable to anyone for any indirect, special or consequential damages. The information and specifications in this document are subject to change without notice.