

Data Hiway Planning

DH02-501

System Site Planning

***Data Hiway
Planning***

**DH02-501
Release 500
9/95**

Copyright, Notices, and Trademarks

Printed in U.S.A. – © Copyright 1995 by Honeywell Inc.

Revision 01 – September 11, 1995

While this information is presented in good faith and believed to be accurate, Honeywell disclaims the implied warranties of merchantability and fitness for a particular purpose and makes no express warranties except as may be stated in its written agreement with and for its customer.

In no event is Honeywell liable to anyone for any indirect, special or consequential damages. The information and specifications in this document are subject to change without notice.

This document was prepared using Information Mapping® methodologies and formatting principles.

TDC 3000 is a trademark of Honeywell Inc.

Information Mapping is a trademark of Information Mapping Inc.

Honeywell
Industrial Automation and Control
Automation College
2820 West Kelton Lane
Phoenix, AZ 85023
(602) 313-5669

About This Publication

This publication, when used with *System Site Planning*, will assist the user in planning a TDC 3000^X system installation. *System Site Planning* will guide the user to planning the environment, power, and grounding required for TDC 3000^X system equipment.

This publication will guide the user to planning the requirements of a Data Hiway system. For more detailed information refer to the Site Planning manual for the specific Data Hiway equipment being used. These publications are found in the BASIC Product binders.

Table of Contents

SECTION 1 – INTRODUCTION.....	1
1.1 Overview.....	1
1.2 Site Development.....	5
1.3 Site Layout.....	6
SECTION 2 – PLANNING THE OPERATOR AREA.....	9
2.1 Overview.....	9
2.2 BASIC Operator Area Design.....	16
2.3 Media Storage.....	18
2.4 Floors.....	19
2.5 Soundproofing.....	19
2.6 Control-Room Lighting.....	19
2.7 Electromagnetic Interference.....	19
2.8 Safety.....	19
2.9 Fire Precautions.....	19
2.10 Communications.....	19
2.11 Emergency Lighting.....	20
2.12 Air Conditioning.....	20
2.13 Air Filtration.....	20
2.14 Process Plant Environment.....	21
2.15 Process Plant Environmental Guidelines.....	24
2.16 Further References.....	27
SECTION 3 – INPUT/OUTPUT AREAS.....	29
3.1 Overview.....	29
3.2 Planning Input/Output Areas.....	30
3.3 Cabling Considerations.....	32
3.4 Types of Cabinetry.....	33
3.5 Multifunction Control Design.....	36
3.6 Cabinet Placement Considerations.....	36
SECTION 4 – WIRING CONSIDERATIONS.....	39
4.1 Overview.....	39
4.2 AC Power.....	41
4.3 Power Distribution.....	43
4.4 BASIC Operator Station (BOS).....	44
4.5 Local Batch Operator Station (LBOS).....	47
4.6 Uninterruptible Power System.....	49
4.7 Input/Output Cabinets.....	50
4.8 Battery Backup.....	53
4.9 Conduit and Cable Trays.....	53
4.10 DC Power Distribution.....	54
4.11 DC Power Distribution to Input/Out Cabinets.....	56
4.12 Batch Control System Power Distribution.....	57
4.13 Controller File to Terminal Panel Voltage Drop.....	58
4.14 Marshalling Systems.....	59
4.15 System Interconnections.....	60
4.16 50-Conductor Cables.....	61
4.17 25-Conductor Cables.....	62
4.18 56-Conductor Cables.....	63
4.19 C-Link Communications Cables.....	64
4.20 Multiconductor Cable Routing.....	66
4.21 Signal Wiring.....	67
4.22 Potential Noise Sources.....	69
4.23 Methods of Signal Protection.....	70

Table of Contents

4.24	Impedance Coupling.....	71
4.25	Bonding.....	73
4.26	Signal Cable and Connection.....	74
4.27	Data Hiway Cable System.....	76
4.28	Approved Data Hiway Cable.....	77
4.29	Cable Installation.....	78
4.30	Data Hiway Cable Installation.....	79
4.31	Data Hiway Electrical Loading.....	83
4.32	Data Hiway Address Capacity/Assignments.....	83
4.33	Preferred Devices.....	85
4.34	Data Hiway Noise Shielding.....	85
4.35	Branch-Length and Polled Device-Addressing Constraints.....	86
4.36	Preferred-Device Wiring.....	93
4.37	Installing Underground Conduit.....	93
4.38	Purging Conduit.....	94
4.39	Intrinsically Safe Wiring.....	95
SECTION 5 – GROUNDING CONSIDERATIONS		101
5.1	Overview.....	101
5.2	Codes and References.....	103
5.3	Ground Sites.....	103
5.4	Isolation.....	104
5.5	Ground Loops.....	105
5.6	AC Safety Ground System (Mains) Ground.....	107
5.7	Basic Operator Station Safety Ground.....	109
5.8	Local Batch Operator Station—AC Safety Ground.....	109
5.9	Interposing Relay Terminal Panel Grounds.....	109
5.10	Cabinet Safety Ground.....	110
5.11	Data Entry Panels Case Ground.....	111
5.12	Lightning Grounds.....	112
5.13	Basic Operator Station DC Ground.....	114
5.14	LBOS Ground.....	115
5.15	C-Link Grounds.....	116
5.16	Single Cabinet DC Ground.....	117
5.17	Multiunit Cabinet DC Ground.....	118
5.18	Separated Controller Files and Terminal Panel.....	119
5.19	Hiway Traffic Director Ground.....	121
5.20	HTD Power and Ground.....	122
5.21	Preferred Device Wiring Shield Ground.....	123
5.22	Data Hiway Shields Ground.....	124
5.23	Signal Grounds for Devices on the Data Hiway.....	124
5.24	Hiway Gateway Wiring.....	125
5.25	Intrinsic Safety Grounds.....	129
5.26	High Level and Low Level PIU Ground.....	133
5.27	Low Energy CFA Ground.....	134
5.28	Fiber Optic Link Grounds.....	135
5.29	Marshalling Panel Grounds.....	136
5.30	Field Device Grounds.....	137
5.31	Grounding Summary.....	138

Table of Contents

APPENDIX A – CONSOLES AND CABINETS.....	141
A.1 Overview.....	141
A.2 Upright Cabinets.....	142
A.3 BASIC Cabinet Cable Routing.....	143
A.4 Operating Center Console.....	144
A.5 Console Development for Layout.....	145
A.6 LCN Style Console.....	146
A.7 Basic System Layout Templates.....	147
A.8 Remote Multiplexer Box	154
A.9 Barrier Box.....	155
A.10 LEPIU Layout Information.....	156
A.11 TDC 3000 ^X Sample Layout for Hazardous Areas.....	157
APPENDIX B – POWER REQUIREMENTS FOR BASIC EQUIPMENT	159
B.1 Overview.....	159
B.2 Basic Systems Power Requirements.....	160
B.3 Basic Power Supplies.....	170
B.4 Advanced Multifunction Controller (A-MC) Modules.....	171
APPENDIX C – SITE GROUNDING EXAMPLES	173
C.1 Overview.....	173
C.2 Console Located in Operator Area	174
C.3 Grounding Intrinsically	177
C.4 Batch Control System Grounding.....	178
C.5 Batch Control System's 56-Conductor Cable Shield Grounding	179
C.6 Hiway Coupler Modules Used as Energy Barrier	180
C.7 Typical Power Distribution for PIU.....	182

Figures and Tables

Figure 1-1	Distributed Architecture Design Modules.....	2
Figure 1-2	TDC 3000 ^X System with Hiway Gateways.....	4
Figure 2-1	Two Bay Operating Center.....	10
Figure 2-2	Operator Console with Three Operator Stations.....	11
Figure 2-3	Expanded Operating Center.....	11
Figure 2-4	Base Cabinet (Operator Station).....	12
Figure 2-5	Base Cabinet (Operator Station).....	13
Figure 2-6	Base Cabinet with Table Top.....	14
Figure 2-7	Wedge Unit (Console).....	15
Figure 2-8	Typical Operator Layout.....	17
Figure 3-1	Standard Cabinet—Exploded View.....	31
Figure 3-2	Cabinet With Files, Power Supply and Terminal Panels.....	34
Figure 3-3	Complexed Cabinets.....	34
Figure 3-4	Typical Input/Output Area Layout.....	37
Figure 4-1	AC Power Source.....	42
Figure 4-2	Basic Operator Station with Remote AC Panel.....	45
Figure 4-3	Console with Integral Breaker Panel.....	46
Figure 4-4	AC Wiring to LBOS Console.....	48
Figure 4-5	Routing of AC Power Wiring from Separate Breaker Panel.....	51
Figure 4-6	Routing of AC Power Wiring from Cabinet-Mounted Power Boxes, either Circuit-Breaker Panels or Junction Boxes.....	52
Figure 4-7	DC Power and Bus Bar System.....	54
Figure 4-8	50-Conductor Cable.....	61
Figure 4-9	56-Conductor Cable.....	63
Figure 4-10	C-Link Cabinet Cable Assembly.....	65
Figure 4-11	C-Link Communications Network.....	68
Figure 4-12	Data Hiway Connected Devices (Boxes).....	76
Figure 4-13	HTD at the End of a Branch.....	80
Figure 4-14	HTD Between Ends of a Branch.....	80
Figure 4-15	Bamboo Hiway Cable (BHC) Connections.....	81
Figure 4-16	HCM at Either End of a Fiber Optic Link.....	82
Figure 4-17	Data Hiway Branch with Two Fiber Optic Links.....	89
Figure 4-18	TDC 3000 ^X System Showing One Branch.....	92
Figure 4-19	Intrinsically Safe Wiring For Auxiliary Files.....	96
Figure 4-20	Barrier Panel Wiring.....	97
Figure 5-1	Instrument Loop with Single Ground.....	105
Figure 5-2	Instrument Loop With Two Grounds.....	106
Figure 5-3	Service Panel and MAINS Ground Rods.....	107
Figure 5-4	Power Source With a Dedicated Transformer.....	108
Figure 5-5	Data Entry Panel Case Ground.....	111
Figure 5-6	Lightning Ground (General Purpose Area).....	113
Figure 5-7	LBOS Safety Ground and Logic Common Grounds.....	115
Figure 5-8	C-Link Shield Grounding.....	116
Figure 5-9	Single Cabinet DC Ground.....	117
Figure 5-10	Local Reference Bar.....	118
Figure 5-11	Separate Dedicated Power Circuits.....	120
Figure 5-12	Preferred.....	121
Figure 5-13	Preferred Device Terminal Wiring.....	123
Figure 5-14	Hiway Gateway Interface Card Showing TB1.....	126
Figure 5-15	Overview of Preferred Access Cabling.....	127
Figure 5-16	Preferred Access Priorities—Without HTD(using HG—HTD).....	128
Figure 5-17	Barrier Panel C-TBU10 Ground.....	130
Figure 5-18	LEPIU Barrier Box PISBIX Ground Connector.....	131
Figure 5-19	Alternate Zener Barrier Ground System.....	132
Figure 5-20	High Level and Low Level PIU Ground Connections.....	133
Figure 5-21	LEPIU CFA Ground.....	134
Figure 5-22	Marshalling Panel Grounds.....	136

Figures and Tables

Figure 5-23	Typical Grounding Methods.....	139
Figure 5-24	Typical Grounding Methods.....	140
Figure A-1	Upright Cabinet Dimensions	142
Figure A-2	BASIC Cabinet Wire Routing.....	143
Figure A-3	Console Base and Wedge Units.....	144
Figure A-4	New Style Console.....	146
Figure A-5	BASIC System Layout Template #1.....	147
Figure A-6	BASIC System Layout Template #2.....	148
Figure A-7	BASIC System Layout Template #3.....	149
Figure A-8	BASIC System Layout Template #4.....	150
Figure A-9	BASIC System Layout Template #5.....	151
Figure A-10	BASIC System Layout Template #6.....	152
Figure A-11	New Style Consoles.....	153
Figure A-12	Dimension and Specifications for Remote Multiplexer Box.....	154
Figure A-13	Dimension and Specifications for Remote Multiplexer Box.....	155
Figure A-14	LEPIU Cabling	156
Figure A-15	TDC 3000 ^X Sample Layout for Hazardous Areas.....	157
Figure C-1	Operator Console Located in Operator Area	174
Figure C-2	Cabinet Located in I/O Area	175
Figure C-3	PIUs Located in a Remote Area.....	176
Figure C-4	Grounding Intrinsically Safe Systems.....	177
Figure C-5	Batch Control System Grounding.....	178
Figure C-6	Batch Control System's 56-Conductor Cable Shield Grounding	179
Figure C-7	HCM Used as Energy Barrier.....	180
Figure C-8	HCM Used as Energy Barrier.....	181
Figure C-9	Typical Power Distribution Schematic for PIU.....	182
Table 2-1	Copper Reactivity.....	22
Table 2-2	Corrosive Compounds	24
Table 3-1	Standard Cabinet Descriptions.....	33
Table 4-1	AC Power Source	41
Table 4-2	50-Conductor Cables.....	61
Table 4-3	25-Conductor Cables.....	62
Table 4-4	56-Conductor Cables.....	63
Table 4-5	C-Link Communications Cables.....	64
Table 4-6	Low Level Analog Signal Cable Types.....	74
Table 4-7	High Level Analog Signal Cable Types	75
Table 4-8	Digital Input and Output Signal Cable Types.....	75
Table 4-9	Approved Data Hiway Cable.....	77
Table 4-10	Maximum Safe Pull Forces for Coax Cable.....	82
Table 4-11	Data Hiway Address Assignments	84
Table 4-12	FM's Maximum Allowable Values For Inductance and Capacitance	99
Table 5-1	Current Flow Between File Systems and Terminals.....	119
Table 5-2	Wire Size for Connection Between Files and Terminal	119
Table B-1	Basic System Power Requirements—Operator Interface	160
Table B-2	Basic System Power Requirements—DC Power	162
Table B-3	Basic System Power Requirements—Auxiliaries	164
Table B-4	Basic System Power Requirements—PIU I/O Modules	167
Table B-5	Basic System Power Requirements—PIU	168
Table B-6	Basic Power Supply Specifications.....	170
Table B-7	A-MC Module Power Consumption	171

Acronyms

AMC.....	Advanced Multifunction Controller
AWG.....	American Wire Gauge
BASIC.....	Control Equipment Connected to the Data Hiway
BOS.....	BASIC Operator's Station
CB.....	Basic Controller
CCFA.....	Common Card File Assembly
CRT.....	Cathode Ray Tube
dB.....	Decibel
DEP.....	Data Entry Panel
DHI.....	Data Hiway Interface
EC.....	Extended Controller
EIA.....	Electronic Industries Association
EMI.....	Electromagnetic Interference
FG.....	Frame Ground
FM.....	Factory Mutual
GPCI.....	General Purpose Computer Interface
HCM.....	Hiway Coupler Module
HG.....	Hiway Gateway
HIM.....	Hiway Interface Module
HLPIU.....	High Level Process Interface Unit
HPE.....	Preferred Access Expanders
HTD.....	Hiway Traffic Director
I/O.....	Input/Output
IEEE.....	Institute of Electrical and Electronic Engineers
IR.....	Current (I) Resistance (R)
ISA.....	Instrument Society of America
LBOS.....	Local Batch Operator Station
LC.....	Logic Common
LCN.....	Local Control Network
LEPIU.....	Low Energy Process Interface Unit
LLPIU.....	Low Level Process Interface Unit
MC.....	Multifunction Controller
MRG.....	Master Reference Ground
MUX.....	Multiplexer
NEC.....	National Electric Code
NFPA.....	Protection Association
PCSI.....	Personal Computer Serial Interface
PIU.....	Process Interface Unit
PMC.....	Process Monitor and Control
PMX.....	Process Monitor (for Exxon)
PSC.....	Power Supply Common
RTD.....	Resistive Temperature Detector
SC.....	Signal Common
SEER.....	Steam Electric - Evaluation and Recording
UPS.....	Uninterruptible Power System

References

Publication Title	Publication Number	Binder Title	Binder Number
<i>TDC 3000^X System Site Planning</i>	SW02-550	System Site Planning -1	TDC 3020 -1
<i>LCN Planning</i>	SW02-501	System Site Planning -1	TDC 3020 -1
<i>Process Manager/Advanced Process Manager Planning</i>	PM02-501	System Site Planning -2	TDC 3020 -2
<i>Logic Manager Planning</i>	LM02-501	System Site Planning -2	TDC 3020 -2
<i>Universal Control Network (UCN) Planning</i>	UN02-501	System Site Planning -1	TDC 3020 -1
Installation for Basic Products	Various	BASIC System Summary	TDC 450
System Checkout	SY-09-03	System Checkout	BASIC Product (Tab 25-110)

Section 1 – Introduction

1.1 Overview

Section contents These are the topics covered in this section:

	Topic	See Page
1.1	Overview.....	1
1.2	Site Development.....	5
1.3	Site Layout.....	6

Summary

Honeywell's TDC 3000^X BASIC System is a family of hardware and software modules for implementing process-control systems. The BASIC System provides a distributed control architecture that combines operator interfaces and process input/output modules into operating systems effective at the loop, unit, and plant-control levels. BASIC System modules are tied together through a Data Hiway communications link.

A BASIC System provides all the instrumentation to accomplish the regulatory control task and to support advanced control functions, such as supervisory. It includes modules that provide for the following:

- Process interface and measurement
- Process data transmission throughout the system
- Process displays for regulatory control and data display
- Process data interface to computer systems
- Batch-sequence control, modulating control, and logic functions

Description

BASIC uses distributed-task processing to achieve these objectives. The modules can be divided into separate areas because of the distributed-architecture design (Figure 1-1). These areas are defined as follows:

- Input/Output Area - Contains equipment card files, process terminal panels, and the necessary support hardware (i.e., power supplies, fans, and a power distribution bus-bar system). These components are mounted in standard 19- or 24-inch cabinets.
- Operator Area - Contains CRT-based operator interfaces, strip chart recorders, analog indicators, annunciator panels, and any peripherals (e.g., line printers). These components are mounted in operating-center-console furniture and/or display panels.

Continued on next page

1.1 Overview, Continued

Description ,
continued

Depending on the size, complexity, and geographic considerations of the control system, the site can have one or more of these areas. Process communications between the input/output and operator areas is accomplished through the Data Hiway redundant cables that provide communications integrity—one cable backs up the other. The Data Hiway can have three branches, each 6096 meters (20,000 feet) long. For batch control, the system can include the Multifunction Controller (MC) and the Local Batch Operator Station (LBOS). Each MC is connected to the Data Hiway. The MCs and the LBOS are connected by the C-Link cable, which has a maximum length of 100 meters (325 feet).

Illustration
Figure 1-1 Distributed Architecture Design Modules

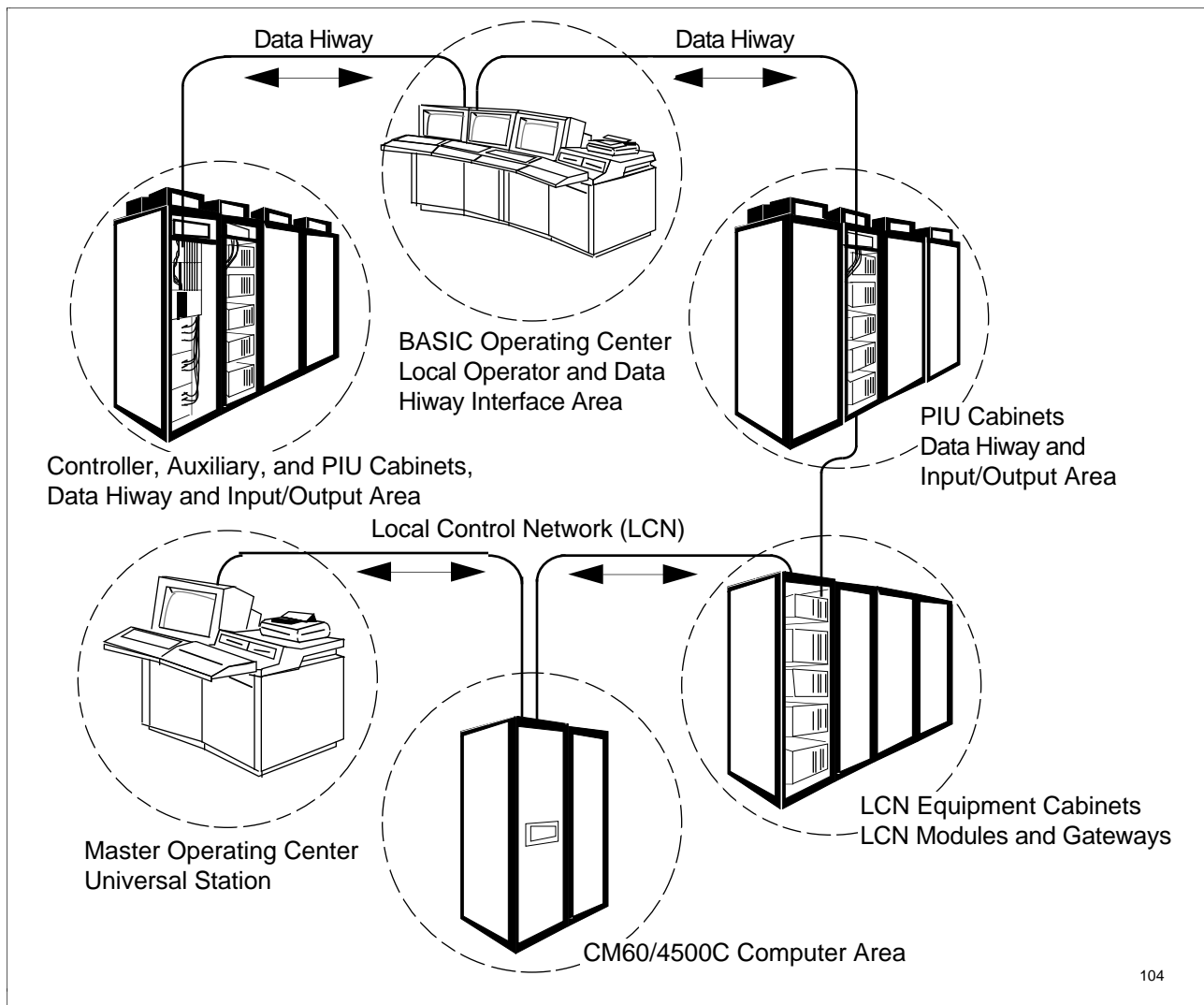

104

Continued on next page

1.1 Overview, Continued

Description, continued

- Operating Center—Contains the TDC 3000^X system equipment and the computer(s). The various Local Control Network (LCN) modules and gateways, shown in Figure 1-2, are housed in the Universal Station console and the equipment cabinet(s). The LCN coaxial pair has a maximum length of 300 meters (1000 feet).

The Universal Station has access to all data and provides the highest level of operator access for plant-wide optimization and scheduling.

In addition to operator and input/output areas, the site will have field equipment areas where transmitters and valves are located and, possibly, a computer area. Process signals between field devices and the input/output area(s) are hard-wired connections.

After you have selected the site, you will wish to design the control system areas based on the plant's operational requirements. These areas should be designed to accommodate cabinets and operating-center-console furniture. Your design will provide for conduit, cable trays, and troughs to bring ac power and safety grounds, process signals and signal grounds, and the interconnecting Data Hiway to the cabinets and control centers. Honeywell project documentation will identify the actual termination points for these connections. DC power distribution to card files, terminal panels, and CRTs and multiconductor cable connections between card files and terminal panels will have already been assembled within the cabinets and operating-center consoles.

For supplemental information, operating-center requirements, and details on system components not covered in this manual, refer to the following documents, which will be transmitted during the course of the project:

Honeywell Customer Information Drawings

- 30734000 Series
- TDC 3000^X System Design Manual
- TDC 3000^X System Manuals

Computer areas have requirements that are referred to by their respective manuals. For site planning information on the Honeywell 4500 process computer, refer to publication PTH-020. For the TDC 3000^X, refer to those publications in the references section.

Continued on next page

1.1 Overview, Continued

Description,
continued

Figure 1-2 TDC 3000^X System with Hiway Gateways

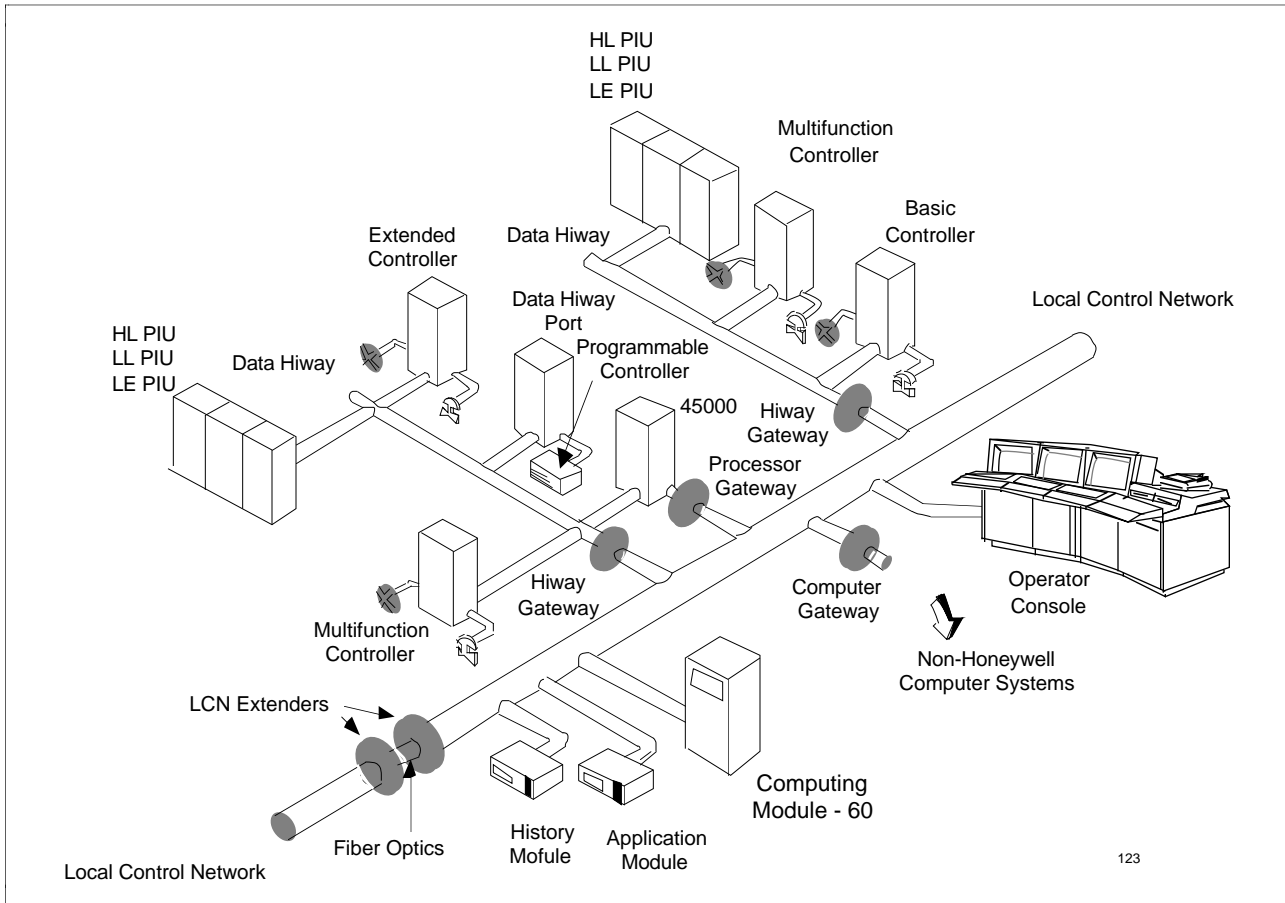

1.2 Site Development

Distributed I/O advantages

If the operator area and the input/output areas are remotely distributed along the Data Hiway, the following advantages can be derived:

- The size of the central control room is greatly reduced, there by reducing the noise, traffic problems, and possible distractions to the operator that can occur when one area has too much equipment.
 - The operator's immediate responsibility is only to the operating center and to specific displays necessary to operate the system.
 - Input/output areas remotely located along the Data Hiway greatly reduce the costs incurred through separation, shielding, and “hard-wire” runs. (For more information on this subject, refer to Sections 4 and 5 of this manual.)
-

Centralized I/O advantages

If the BASIC Operator area and input/output areas are centrally located in one room or an adjacent room in the same building, the following advantages can be derived:

- Environmental protection can be provided more economically because all equipment will be in the shared area of the support systems.
 - Maintenance requirements may be reduced or consolidated.
-

Selection

The type of installation that you select should be governed by such considerations as costs, operating procedures, maintenance procedures, safety procedures, and adaptation to your particular site. The advantages of each type of system installation are important when determining the space requirements for a new plant site; they become vital when an existing site is being altered to accommodate a new process or control system. With today's rising constructions costs, the problem of providing adequate space for a large centralized control operation might make your preliminary space appropriation for instrumentation and control equipment an insurmountable task. The Honeywell TDC 3000^X system flexibility offers you a number of sensible solutions to the problem.

1.3 Site Layout

Site layout parameters

When the TDC 3000 BASIC Operator area and input/output areas are being selected, consider the following:

- Total Area - Allow adequate space for efficient operation of the system equipment, for associated activities, and for anticipated expansion.
- Disruption - Existing facilities may be temporarily disrupted while the system is being installed.
- Work Flow - For efficient work flow consider related work areas, human factors, storage problems, and noise isolation.
- Environmental Considerations
 - Proximity - Must the process operation be viewed from the control area? Is the process area within the limits of the control equipment, communication equipment, maintenance personnel?
 - Access - Is there easy access to the control equipment by process-operation and technical support personnel?
 - Contamination - Are the control areas in the least contaminated area away from processes that may tax the environmental equipment? Examples: Odors, particulates, condensation, corrosion, noise. Consider prevailing winds.
 - Explosion - Locate all control areas at a safe distance from processes that have explosive possibilities.
 - Salt Damage - If your site is located in a salt-air environment, make every effort to protect your control areas from direct exposure to the salt air. Salt buildup of equipment or abnormal breakdown of air filter systems would be inevitable.
- Service - Space should be provided in or near the operator area for the storage and protection of media, equipment, and spare parts.
- Security - To protect both data and equipment, security measures are essential. These include
 - Physical Security - Fire and other damage controls, including controlled personnel access.
 - Control and Procedures - The audit of personnel, clearly defined areas of responsibility, and controlled access to operator areas and input/output areas.
 - Recovery and Back-up Procedures - The protection of record storage to ensure continued operation. Duplication and separate storage areas of priority, sensitive, and crucial data is recommended.
- Electric Power- Adequate, reliable power must be available for the equipment at each control area you select.
- Electromagnetic Interference Evaluate the effect of sources of EMI in the vicinity of the control equipment.

Continued on next page

1.3 Site Layout, Continued

Site layout parameters, continued

- Structural Requirements - Is space available to house air-conditioning equipment such as compressors, air-handling equipment, evaporators, condensers, and cooling-tower equipment? Can new equipment be added without causing radical changes to the current allocation of space? Is lighting arrangement adequate? Are the availability and the locations of power adequate? Is the floor loading of existing equipment areas adequate to sustain the equipment's weight plus any other loads that may be imposed upon it? Will it withstand future expansion loads?
-

Preparation

After evaluating the site for possible location of control areas, you should prepare several equipment layouts for each area, as well as a general site-layout plan or plans. Sample layouts accompanied by photographs and complete specifications provide the most thorough means of site-layout evaluation, and help make the decisions necessary for final site layout approval.

A typical site equipment layout should show the following:

- Adjacent corridors, ramps, and staircases
- Building columns and internal windows
- Media-storage areas
- Under-the-floor or above-the-floor obstructions that affect installation or routing of interconnecting cables.
- Raceways or walk ways
- Proposed cable-tray layout or underground-conduit runs
- Grounds
- AC Load Centers
- Communications Terminals

To summarize, when the operational requirements have been determined, the space requirements for the system have been met, and the overall site equipment layout has been determined, you are ready to proceed with the planning of the individual areas.

Section 2 – Planning the Operator Area

2.1 Overview

Section contents

These are the topics covered in this section:

	Topic	See Page
2.1	Overview.....	9
2.2	BASIC Operator Area Design.....	16
2.3	Media Storage.....	18
2.4	Floors.....	19
2.5	Soundproofing.....	19
2.6	Control-Room Lighting.....	19
2.7	Electromagnetic Interference.....	19
2.8	Safety.....	19
2.9	Fire Precautions.....	19
2.10	Communications.....	19
2.11	Emergency Lighting.....	20
2.12	Air Conditioning.....	20
2.13	Air Filtration.....	20
2.14	Process Plant Environment.....	21
2.15	Process Plant Environmental Guidelines.....	24
2.16	Further References.....	27

Scope

The equipment in the operator area features an operating center that can accommodate optional support equipment, such as strip-chart recorders or printers. This equipment is usually built into the console at the customer's request. Also built into the console are the operator station keyboards and the display units.

To create an environment conducive to efficient operation, the operating center should be quickly approachable and visible to the operator from all likely stations.

This section of the manual will assist in the preliminary planning and design of your operator area.

Continued on next page

2.1 Overview, Continued

Recommended BASIC operating center arrangement

The recommended configuration of an operating center consists of two or three identical but independent operator stations. Figures 2-1 and 2-2 show two views, A and B. In each figure, view A illustrates the original style console design and view B illustrates the new-style console design. New-style consoles are always supplied as dual units so that there is no 3-bay configuration with or without horizontally mounted diskette drives. Operating centers, regardless of console configuration, are for use by a single operator.

Figure 2-1 Two Bay Operating Center

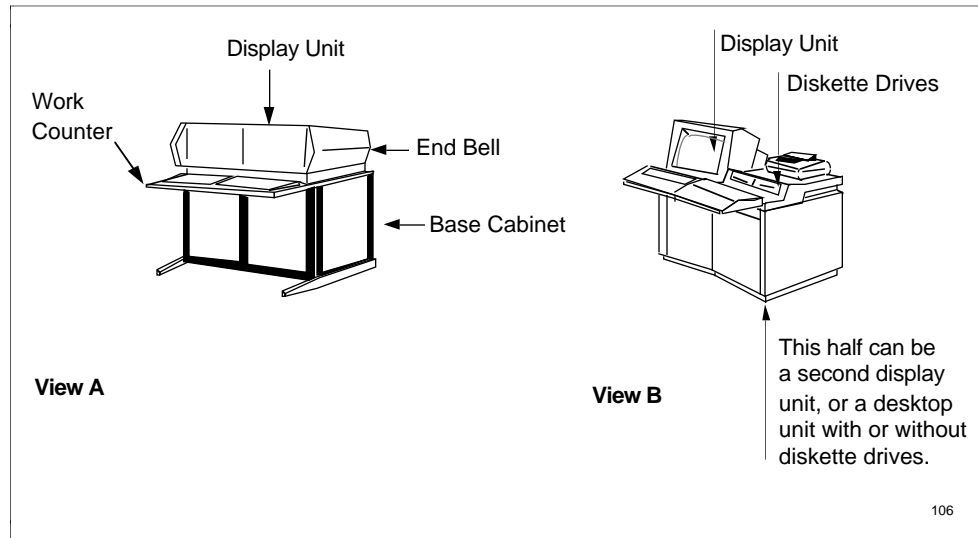

Continued on next page

2.1 Overview, Continued

Recommended BASIC
operating Center
arrangement,
continued

Figure 2-2 Operator Console with Three Operator Stations

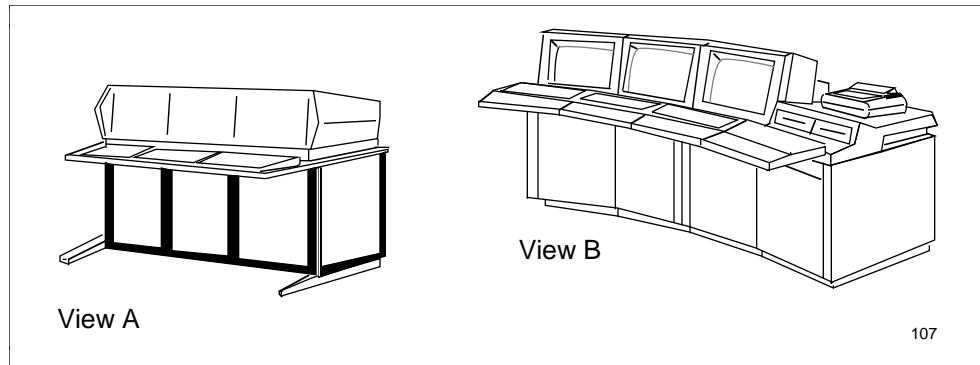

Original-style operating centers accommodate peripheral equipment such as printers, cassettes, floppy disks, etc. by adding table-top bays and wedge units, as shown in Figure 2-3.

Figure 2-3 Expanded Operating Center

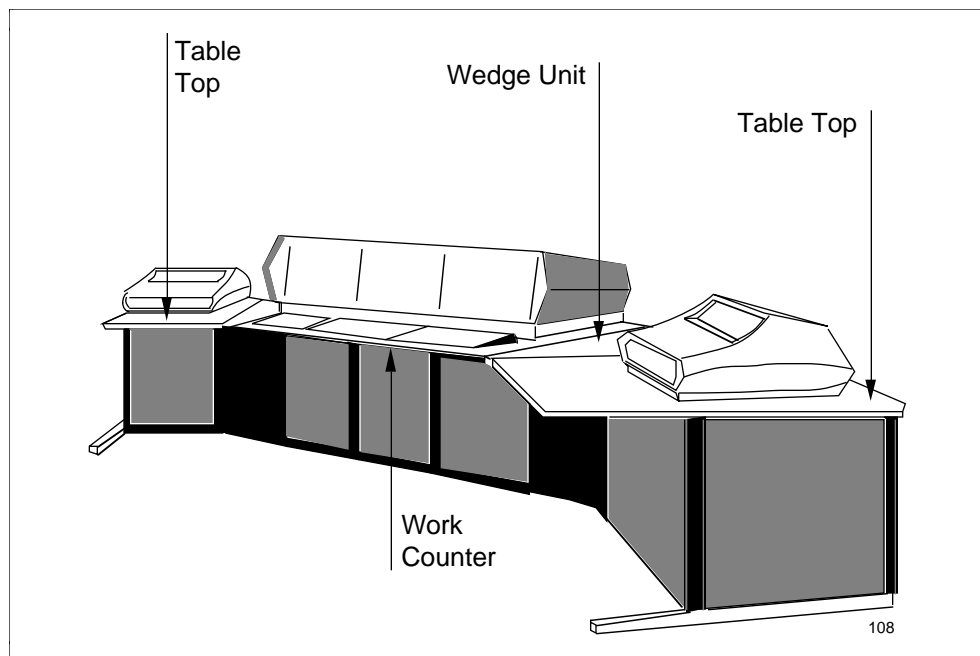

Continued on next page

2.1 Overview, Continued

**Recommended BASIC
operating center
arrangement,
continued**

The 3-station operating center has the following features:

- One station dedicated to overviews
- One station dedicated to operator process manipulation
- One station dedicated to alarms and/or trend displays
- All stations are the same and are interchangeable

The basic unit of the original-style console design is the small base cabinet shown in Figure 2-4. Up to five can be shipped as a unit, but any number can be used as required to make up the base of an operating center console. When used as the base of an operator station, the base cabinet houses electronics and supports a display unit (Figure 2-5). The basic unit of the new-style console is the dual unit that can be specified for two display units, including recorders, two table-top units with or without horizontal drives, or a combination such as shown in Figure 2-1.

Figure 2-4 Base Cabinet (Operator Station)

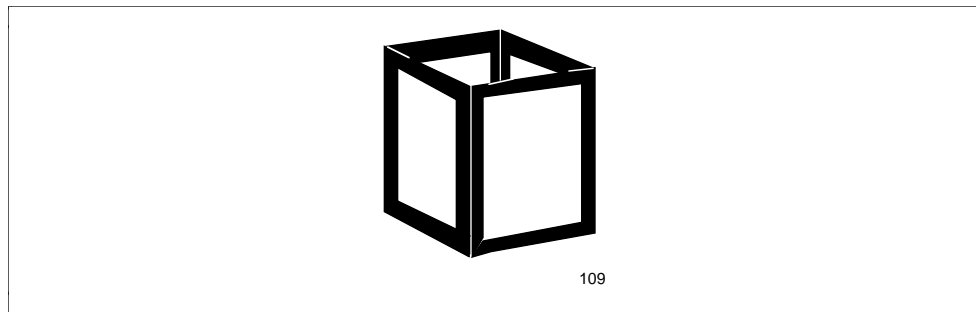

Continued on next page

2.1 Overview, Continued

**Recommended BASIC
operating center
arrangement,
continued**

Figure 2-5 Base Cabinet (Operator Station)

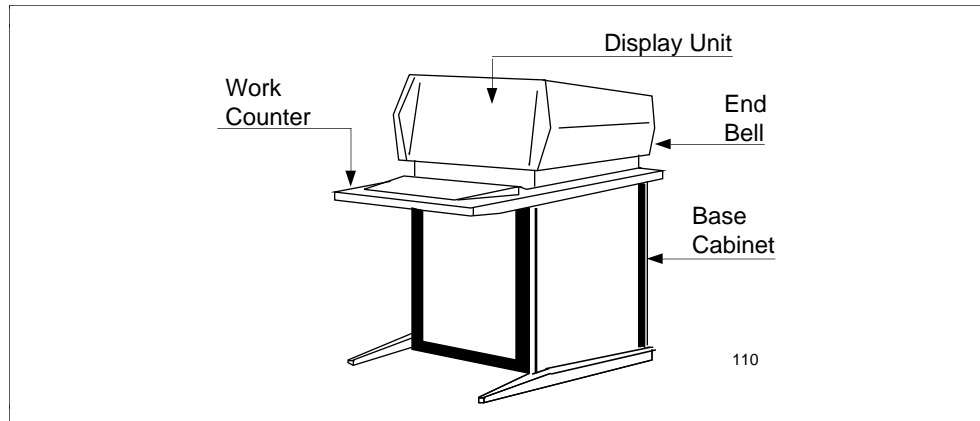

Monitors and CRTs

Monitors and CRT displays used in an operating-center console are housed in a display unit. The display unit electronics and power supplies are factory-installed, interconnected, and tested before shipment.

Continued on next page

2.1 Overview, Continued

Work surface

A table top can be added to the base cabinet to accommodate optional equipment such as electronic equipment or printers, or to serve as a desk top. Honeywell will customize it to your needs (Figure 2-6).

Figure 2-6 Base Cabinet with Table Top

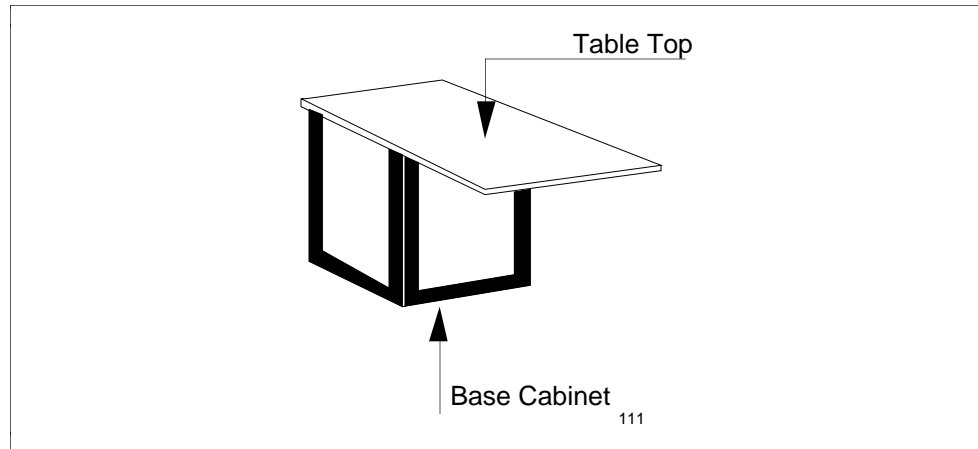

When more than one base cabinet is shipped as a single unit, the table top is shipped with the bases and the top as a single unit, for up to five units. Shipping splits are indicated in Appendix A.

Continued on next page

2.1 Overview, Continued

45° table-top wedge

In addition, 45-degree, table-top wedge combinations are available (Figure 2-7) . They can consist of angle base frames mounted to a cabinet base, resulting in a minimum of wasted space. They allow the console designer a degree of flexibility not possible in a straight-line type console. The wedge unit is equipped with mounting hardware for files, HTDs, or floppy disk-drive unit(s) and can be used in place of an extra bay. Small support equipment and communications devices can be mounted in the wedge portion of the console without appreciably lengthening the console itself. Further, a "tucked in" or somewhat U-shaped design saves space in the operator area, is sometimes more aesthetically appealing than straightline design, and affords the operator a narrower range of movement and increased visual accessibility to displays and printouts.

The dimensions, base-cabinet basewedge-unit construction, and other information necessary to approximate space requirements for your operating-center console are given in Appendix A, Figure A-3.

Figure 2-7 Wedge Unit (Console)

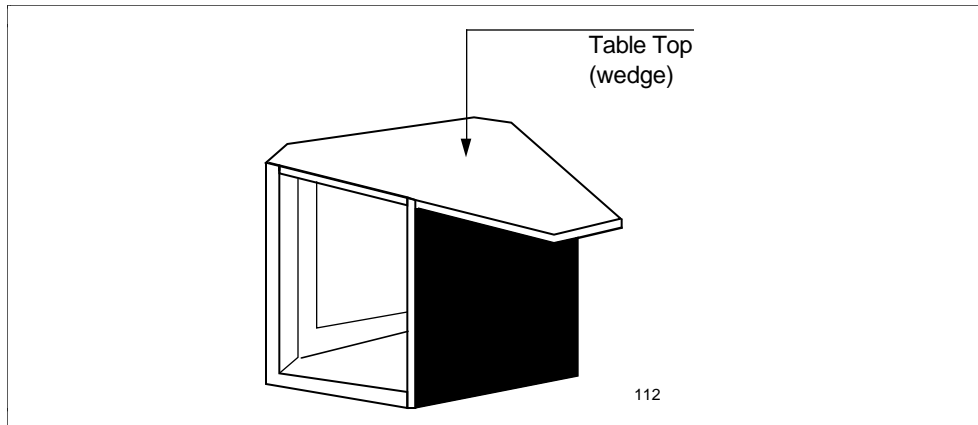

2.2 BASIC Operator Area Design and Layout

Flexibility	As noted in the previous discussion, the flexibility offered by the BASIC System enables the designer to limit equipment required in the operator area to the operator stations, optional computers, and peripherals such as magnetic-tape units, floppy disk unit, card punch, card reader, printer, storage and maintenance cabinet, and process-display panels.
Evaluation	Minimum area requirements are determined by the size, number, and clearances required for operation and maintenance of the equipment. Some overlap of the maintenance clearance (door swings) is permissible, but evaluate each case before final layout approval. When planning your total space requirements, consider the shape of the available space, columns, walls, partitions, entrances, and exits. A nearly square area, free of columns, is sometimes convenient for operating personnel and restricts layout of equipment less than an L-shaped or long narrow area. Growth also requires space.
Preliminary checks	Check the dimensions of all doors, stairwells, elevators, ramps, and turns in corridors to ensure that the equipment can be delivered to the operator area. Aisles must have a minimum width of 1372 mm (54 in.) and should allow access to all equipment, front and rear. Also media supplies, maintenance equipment, and site-storage and maintenance cabinets must fit through the aisles.
Considerations	When planning your operator-area layout, remember to take into consideration operator efficiency, personnel comfort, esthetic appeal, noise minimization, ease of maintenance, and expansion.

Continued on next page

2.2 BASIC Operator Area Design and Layout, Continued

Example

As a guide, a typical BASIC operator area layout is shown in Figure 2-8.

Figure 2-8 Typical Operator Layout

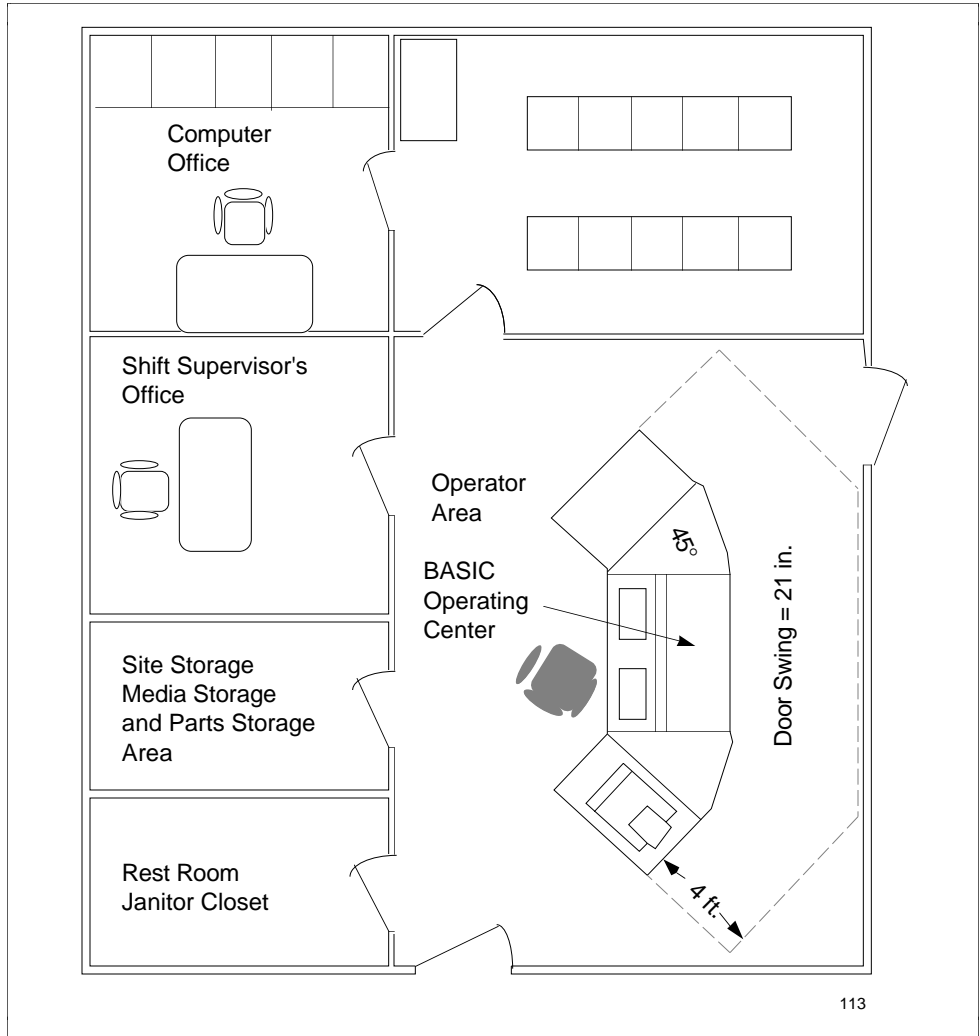

2.3 Media Storage Facilities

Requirements

When designing the media storage facilities consider the following:

- Floppy disks, paper, ribbons, and other media supplies should be stored close to the operator area.
 - Should a computer interface be part of your system, you will also need storage space for magnetic tape, disk packs, and punch cards. Plan for duplication of the critical media and for a separate storage site in a remote area.
 - Controlled storage is suggested for critical magnetic-tape reels or disk packs, and especially for critical diskettes used to configure each system. Store the following where they will be temperature and humidity controlled:
 - System diskettes used for configuration or programming the process-control system.
 - Daily operational data or diskettes trend data and any other printouts.
 - Bulk paper stock and supplies.
 - Storage and operating conditions for diskettes are given in Section 6.
 - When paper products are moved to an area with a different temperature and humidity, they have a tendency to warp, bend, or shrink. A change in humidity of 20%, even with constant temperature, can change the location of the lines or graphic representation, as well as the dimensions of punched holes.
 - Stabilization of cards can take days; stabilization time for a stack of paper can be weeks or even months. To minimize stabilization time, keep the storage area within the same environment as the operator area.
-

2.4 Floors

Reference Refer to *System Site Planning*.

2.5 Soundproofing

Reference Refer to *System Site Planning*.

2.6 Control-Room Lighting

Reference Refer to *System Site Planning*.

2.7 Electromagnetic Interference

Reference Refer to *System Site Planning*.

2.8 Safety

Reference Refer to *System Site Planning*.

2.9 Fire Precautions

Reference Refer to *System Site Planning*.

2.10 Communications

Reference Refer to *System Site Planning*.

2.11 Emergency Lighting

Reference Refer to *System Site Planning*.

2.12 Air Conditioning

Reference Refer to *System Site Planning*.

2.13 Air Filtration

Reference Refer to *System Site Planning*.

2.14 Process Plant Environment

Overview

These guidelines are only suggestions; however, the more aggressively they are followed, the more benefits the user can expect to receive in terms of trouble-free operation. The type and amount of environmental-control measures ultimately used vary greatly from site to site, depending on the process and atmospheres involved. These recommendations are compatible with work being done by the ISA in classifying airborne contaminants and their effects on process-control systems.

Contaminates

Through studies of the contaminants around electrical and electronic equipment, a clear correlation has been shown between environmental severity and equipment reliability. For example, many of the problems recognized by operating personnel as electrical intermittents can now be identified as caused by subtle corrosion reactions produced by low level pollutants. An important new finding from these studies is the extraordinarily low level of specific pollutants required for significant corrosive reactions to occur.

Although sufficiently high concentrations of any one gas usually produces a severe environment, the reverse is not true because gaseous pollutants are only a part of the problem. Other important factors to consider are humidity, temperature, air velocity, and general operating practices. By excluding the effects of these other factors, the amount of any single gaseous pollutant necessary to cause equipment failure appears to be exceptionally high, which leads to incorrect conclusions.

Continued on next page

2.14 Process Plant Environment, Continued

Contaminate classification

Copper reactivity has been found to be a more accurate method of measuring environmental severity than was the measurement of individual gas concentrations, because it integrates the effect of all of the variables. Not only is it more accurate than determining gaseous pollutant levels, but it is also easier to measure. By placing a small copper strip, called a coupon, in the equipment racks and measuring the corrosive-film thickness that develops on the surface over a known period of time, data can be obtained with which long-term equipment reliability predictions can be made. Coupon analysis can be performed by the user, by the manufacturer, or by the specialists who will be designing, installing, and maintaining the air purification system.

Four environmental classifications have been established and are listed in Table 2-1.

Table 2-1 Copper Reactivity

Class	Copper Reactivity (Angstroms/Month)	Description
Mild	Less than 300	Sufficiently well-controlled that corrosion is not a factor in determining equipment reliability.
Moderate	300-1000 °	The effects of corrosion are measurable and may be a factor in determining equipment reliability
Harsh	1000-2000 °	There is a high probability that corrosive attack will occur. These harsh levels should prompt further evaluation, resulting in environmental controls or specially designed and packaged equipment.
Severe	Greater than 2000 °	Only specially designed and packaged equipment would be expected to survive. Specifications for equipment in this class are a matter of negotiation between user and supplier.

° Reactivity greater than 300 angstroms each month does not result in immediate equipment failure; however, problems may start intermittently from the formation of thin corrosion films on contacts or localized dendritic growth between printed wiring-board tracks. These phenomena often occur during brief periods of high humidity and may be temporarily cleared by reseating boards or when humidity returns to a low level. As reactivity approaches 1000 angstroms per month, intermittent failures become more frequent. Above this level, significant degradation of equipment reliability occurs.

2.14 Process Plant Environment, Continued

Guidelines

To minimize corrosive environmental effects, Honeywell recommends that control-room environments be equipped with air conditioning and filtration systems. Some guidelines to help maximize equipment *up-time* are described in this section.

These guidelines fall into four main categories:

- Relative humidity
 - Gas-flow concentrations
 - Air velocity
 - General operating procedures
-

Relative humidity

Control of relative humidity is a very important factor to consider in the prevention of corrosion failures. Corrosive effects on electronic equipment are greatly accelerated, even in the presence of a few parts per billion of atmospheric contaminants, by humidity in excess of 50% or by rapidly changing or cyclically fluctuating humidity. On the other hand, excessively low humidity (less than 40%) may cause static discharge problems with electronic equipment. The following guidelines are therefore recommended:

- Maintain relative humidity levels between 40% and 50%.
 - Control humidity fluctuations to less than 6% per hour-rate-of change.
-

Continued on next page

2.15 Process Plant Environmental Guidelines

Gas flow concentrations

Gas-flow concentrations should be held to low levels to maintain system performance, although by themselves they should not be used to determine the severity of atmospheric conditions. The most prevalent compounds causing corrosion in the process industry are active sulfurs and inorganic chlorides:

Table 2-2 Corrosive Compounds

Compounds	Presence
Inorganic Chlorine Compounds (chlorine, Chlorine dioxide, hydrochloric acid)	These compounds are seldom absent in major installations and in the presence of moisture they readily react with copper, tin, silver, and iron alloys found in electronic components. These reactions can be significant even at chlorine levels in the low parts per billion.
Active sulfurs (hydrogen sulfide, elemental sulfur, organics such as mercaptans)	In an environment with mild reactivity, the concentration of active sulfurs would typically be 2-3 PPB. The presence of moisture and a few tenths PPB of chlorides could increase reactivity into the moderate class or above.
Sulfur oxides (SO₂, SO₃)	In an environment with mild reactivity, the concentration of active sulfurs would typically be 2-3 PPB. The presence of moisture and a few tenths PPB of chlorides could increase reactivity into the moderate class or above.
Other compounds	The effects of other compounds such as nitrogen oxides, ammonia, oxidants, and fluorides are either not precisely known or typically not present in sufficient quantities to warrant special precautions. If a problem with any specific constituent is suspected, a corrosion specialist should be consulted.

Continued on next page

2.15 Process Plant Environmental Guidelines, Continued

Air velocity and purification system

Guidelines for air velocity and air purification should be closely adhered to:

- Positive pressure in equipment rooms should be maintained at approximately 0.1 inches of water.
 - Minimize the quantity of particulates reaching equipment to less than 100 ug/m³. The accumulation of particulates on equipment can be a problem in several ways. They can form leakage paths between conductors or interfere with contacts and switches, or result in corrosion.
 - Diffuse air into rooms away from electronic equipment. Do not directly duct cooled air into cabinets to avoid the possibility of condensation.
 - Size air conditioning units properly and do not alter air flow without consulting the manufacturer. High air flow accelerates corrosive effects.
 - Chemical-purification systems are usually required to provide acceptable air quality in industrial environments. The system should be chosen based on the manufacturer's ability to provide the necessary low levels of pollutants and verification by reactivity monitoring.
 - Take special precautions during equipment installation before energizing equipment to minimize exposure to unfiltered air by the electronic modules.
 - Provide a means to close make-up air inlets during periods of process upset or unusually high external pollutant levels. Take into consideration nearby pollutant sources and prevailing wind patterns when locating air inlets.
-

Continued on next page

2.15 Process Plant Environmental Guidelines, Continued

General operating practices

For the best operating results:

- Do not defeat temperature and humidity controls by opening doors and windows (e.g., to enhance operator comfort).
 - During process upset or air conditioner breakdown, priority should be given to maintaining low relative humidity, minimizing air velocity, and preventing high concentrations of gaseous contaminants from reaching equipment. Allowing temperatures to rise lowers the humidity and does not cause significant short term reliability problems (note that the specified maximum ambient is 50°C, 122°F).
 - Chemical-purification systems should be placed on a strict analysis/replacement schedule. If contamination is suspected, components should be cleaned only with materials, and in a manner, specifically intended for those components (e.g., do not clean edge contacts with an eraser as this removes gold plating and exposes more pore area to future attack). See *TDC Housekeeping Practice* in the *System Checkout Manual (SY-09-03)* before attempting periodic cleaning of the system.
 - Keep equipment doors closed at all times, except during times of actual human access.
 - Traffic through equipment rooms should be restricted, and air locks should be considered, to minimize the ingress of untreated air.
 - All floor finishes should be static inhibiting.
 - Dry-bulb temperature should be kept within 15°C to 30°C (59°F to 86°F),
 - Room make-up air should be kept to less than 10% per hour.
-

2.16 Further References

Installation and checkout

The publications in the BASIC bookset will provide more information. Consult the References section of this publication

Professional publications

The following publications provide further reading:

- Shaw, William T., Installing a Computer Based Process Control System, Instruments and Control Systems, February 1984, Pgs. 49-52.
 - Rice, D.W., et al., Atmospheric Corrosion of Copper and Silver, Electro Chem Sec., Feb. 1981, Pgs. 275-284.
 - Abbott, W.H., The Effects of Operating Environments on Electrical and Electronic Equipment Reliability in the Pulp and Paper Industry.
 - IEEE Industry Application Society Pulp & Paper Technical Conference, New Orleans, May 10-13, 1983.
 - Abbott, W.H., Field versus Laboratory Experience in the Evolution of Electronic Components and Materials, Proceedings of the National Association of Corrosion Engineers, Corrosion '83, Anaheim California, April 13-22, 1983.
-

Section 3 – Input/Output Areas

3.1 Overview

Section contents

These are the topics covered in this section:

	Topic	See Page
3.1	Overview	29
3.2	Planning Input/Output Areas	30
3.3	Cabling Considerations	32
3.4	Types of Cabinetry	33
3.5	Multifunction Control Design.....	36
3.6	Cabinet Placement Considerations	36

3.2 Planning Input/Output Areas

Guidelines

These areas contain process-control equipment enclosed in control cabinets. The equipment includes power supplies, equipment card files, terminal and junction panels, process-interface units, and marshalling panels. If your process control operation requires operator interface equipment other than the operating center or Local Batch Operator Station, Data Entry Panels (DEP), Analog Displays, Digital Displays, or Standby Manual units can be mounted on the control cabinets (Figure 3-1) or separate panels.

As you plan the I/O areas, consider the following:

- Proximity—For ease of operation and technical support, the I/O area may have to be located closer to the process and process operating personnel than would be necessary with an I/O area that has no operator interface.
- Security
 - Fire and other damage controls must be both feasible and available to any I/O location.
 - Controlled personnel access to control equipment. Key-locked cabinets with access allowed only to authorized personnel are sometimes necessary.
- Local operation—Operator interface equipment needed on a regular or intermittent basis outlined below:
 - Complete isolation of the I/O area from the master or secondary operating centers caused by accident, incident, emergency test procedures or requirements for safe shutdown.
 - Parallel paths of PV control and/or indication necessary to verify process information being received by the central control operator.
- Because of 100-meter maximum length C-Link, consider locating the LBOS on a desk or table in the I/O area.
- Intrinsic safety—I/O areas that handle inputs or outputs to a hazardous area should be located so that wire runs are kept to a minimum.

Continued on next page

3.2 Planning Input/Output Areas, Continued

Guidelines, continued

If operating personnel are to be present in an I/O area for a substantial part of the working shift, Section 2, Environmental Conditions, should be followed.

The basic rules of site development and layout as outlined in *System Site Planning* apply to planning the I/O areas as well. This section will assist you in establishing proper interface between field instrumentation and the I/O equipment.

Figure 3-1 Standard Cabinet—Exploded View

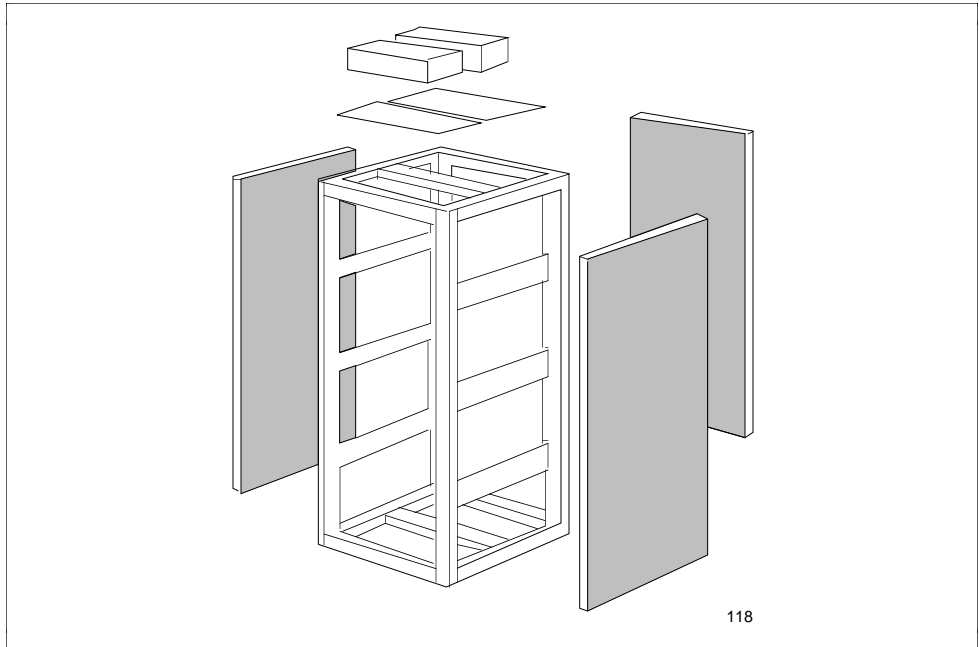

3.3 Cabling Considerations

Guidelines, continued

The major factors to be considered when choosing locations for the input/output areas and distribution of equipment cabinets within the framework of the control buildings are as follows:

- Controller files, Batch Control System, analog units, and process interface units can be located anywhere along the Data Hiway, which can be up to 6096 meters (20,000 ft.) long. The method for computing each branch length of the Data Hiway is shown in Section 4, *Wiring Considerations*.
- In a given Batch Control System, Multifunction Controllers and Local Batch Operator Stations can be located anywhere along the C-Link included in that system. The C-Link can be up to 100 meters (325 ft.) long.
- When a Data Entry Panel (DEP) is used in the I/O area, controller files must be located within 60 meters (200 ft.) of cable run to the DEP (CB to DEP).
- Analog displays (when used) must be located within 60 meters (200 ft.) of cable run to Basic, Batch, or Extended Controller files.
- When terminal panels are separately installed in cabinets (not in same cabinet as controller file), and analog displays are used, the 60-meter cable-run total is accumulatively figured (controller file to terminal panel to analog display).
- If analog displays are not used, terminal panels must be located within 60 meters (200 n.) of cable run to the controller file (CB).
- Regardless of location of the controller file on the Data Hiway, DEPs and analog displays are to be located within 60 meters of cable run to the CB or analog unit.

These parameters, when applied to the distributed-architecture concept of the BASIC System, allow the effective establishment of control centers anywhere along the Data Hiway.

Additionally, a system of marshalling panels can be used to organize the input/output signals in a local area for channeling to terminal panels in the terminal area, or they can be channeled through 50-conductor cables to other panels in remote locations.

For illustrations of the use of marshalling systems, and cabling, wiring, and interconnections, refer to publication T0-20-02.

3.4 Types of Cabinetry

Description

Cabinet hardware for mounting equipment files and terminal panels is designed to fit into a standard 484 mm (19 in.) Electronics Industries Association (EIA) cabinet. When intrinsically safe systems are required, optional hardware is used for mounting in a 611 mm (24 in.) EIA cabinet (see Appendix A, Figure A-12). The additional width is needed to permit safe wiring separation in a separated protected raceway. Cabinet depth can be either 654 mm (25.75 in.) or 781 mm (30.75 in.) depending on the system requirements. Overall cabinet heights can be up to 2060 mm (81 in.). Vertical panel openings can be up to 1925 mm (75.69 in.). The base frame and side plates that make up the standard cabinet are shown in Figure 3-1 and 3-2.

Multiple Units

When a number of equipment files, terminal panels, and process interface units are related to a system of operation in a particular area, cabinets are connected in groups of up to five. These groups, or modules, are shipped as a package, completely assembled and prewired from the factory. The basic dimensions, layout information, and other information necessary to approximate space requirements for your cabinetry are given in Appendix A.

Basic cabinet

Table 3-1 Standard Cabinet Descriptions

Cabinet Type	Specification	Description ...
BASIC Product	Dimension	658.8 mm (27.00 in) Width 2070.1 mm (81.5 in) Height 774.7 mm (30.5 in.) Depth
	Control loops	40
	Maximum number of units Card Files Power Supplies Terminal Panels	5 (front surface) 2 (front surface) 5 (rear surface)
PIU Product	Dimension	658.8 mm (27.00 in) Width 2070.1 mm (81.5 in) Height 774.7 mm (30.5 in.) Depth
	Control loops	48
	Maximum number of units Card Files Power Supplies 7 amp 20 amp Terminal Panels	5 (front surface) 4 2 (front surface) 5 (rear surface)

Continued on next page

3.4 Planning Input/Output Areas, Continued

Basic cabinet,
continued

Figure 3-2 Cabinet with Files, Power Supply, and Terminal Panels

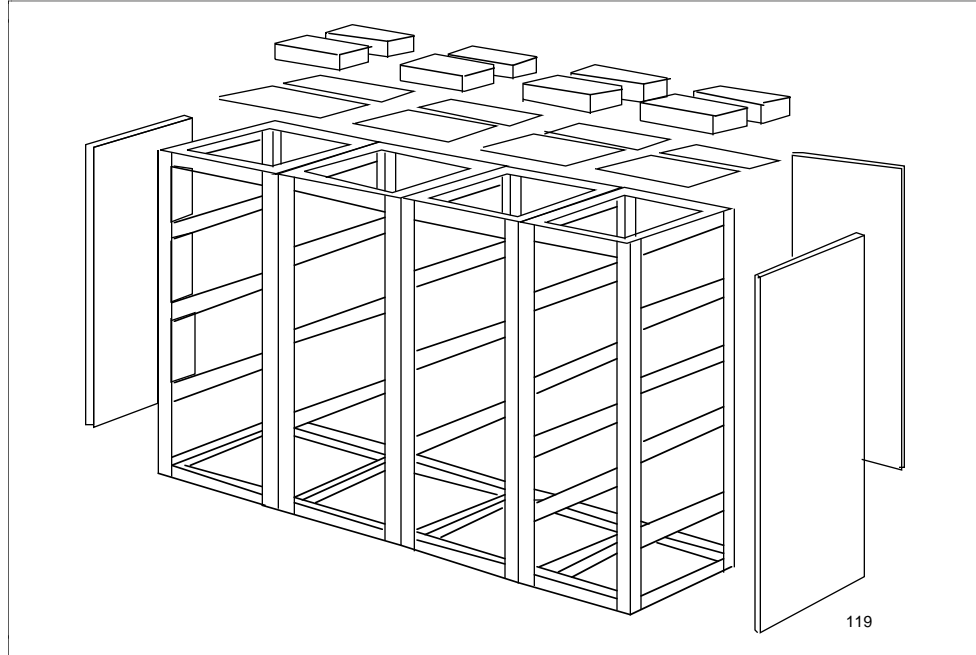
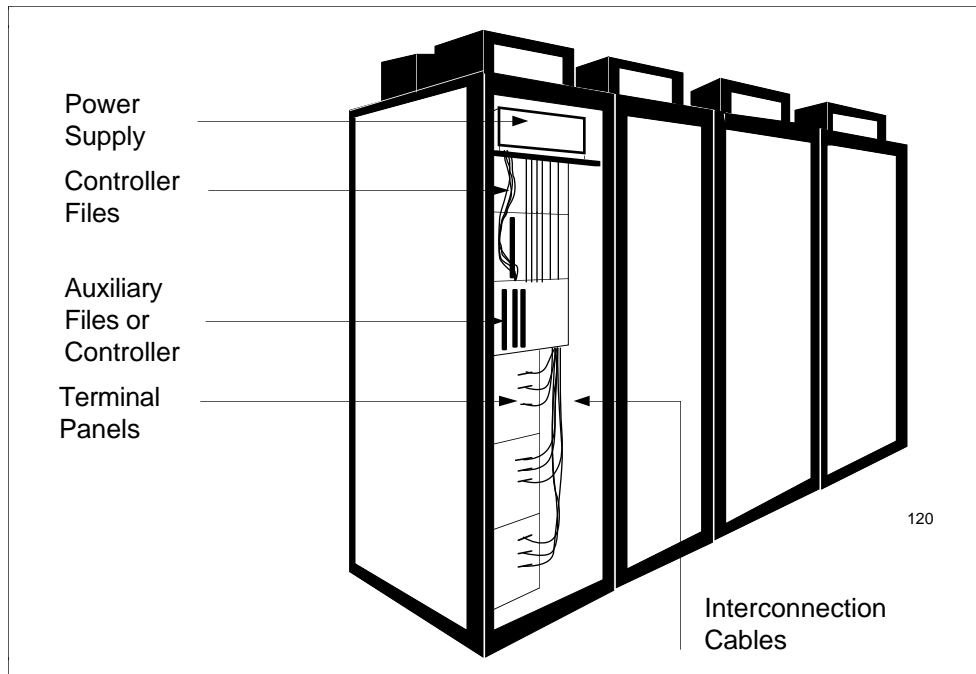

Figure 3-3 Complexed Cabinets



3.4 Types of Cabinetry, Continued

Basic cabinet,
continued

The Basic product cabinet can accommodate 40 control loops with full power-supply capacity. With this design, two power supplies and five equipment files can be located on the front of the cabinet, and five terminal panels can be located on the rear face.

PIU cabinets

The PIU product can accommodate 48 control loops, completely filled from top to bottom. All components except power supplies can be arranged at will within the cabinets. Power supplies can be located only at the top or bottom of each cabinet, depending on field wiring cabinet-entry. A maximum of two 20-amp or four 7-amp power supplies can be accommodated in one side of one cabinet.

A conventional arrangement is to mount three equipment files, three terminal panels, and a power supply on each back pan (Figure 3-3).

3.5 Multifunction Control Design

Description

Each Multifunction Controller and supporting hardware can handle up to 32 analog inputs, 72 analog outputs, 272 digital inputs, and 128 digital outputs, and can simultaneously control up to 16 process sequences. An optional 1925 mm (77 in.) high cabinet is available for expanded systems that can include auxiliaries.

A single 611 mm x 611 mm x 1750 mm (24 in. x 24 in. x 70 in.) high cabinet can contain a maximum of two Batch Controllers mounted back-to-back, each with supporting hardware consisting of a power supply, two point-card files, a controller terminal panel, and two point-card terminal panels.

3.6 Cabinet Placement Considerations

Guidelines

When planning the placement of BASIC System cabinets, the following should be considered:

- Minimum space requirement
 - The number and size of cabinets (including allowances for door clearance, aisles, etc.). Aisles must have a minimum width of 1370 mm (54 in.) and should allow access to all equipment, front and rear, as shown in Figure 3-4. Refer to Appendix A for cabinet dimensions.
 - Shape of available space, obstructions such as columns, partitions, or other equipment, proximity to sources of environmental problems, etc.
 - Related space requirements, such as for air conditioning and utilities equipment, accommodations for personnel needs, and a ground system for BASIC System equipment.
 - Accessibility
 - Doorways, stairwells, elevators, hallways, ramps, and aisles (including turns) must be of sufficient size to permit movement of equipment.
 - The area in which cabinets are housed must be accessible through roads that are passable year-round. Snow, floods, plant expansion, and plant modification must not preclude access.
-

Continued on next page

3.6 Cabinet Placement Considerations, Continued

Guidelines,
continued

Figure 3-4 Typical Input/Output Area Layout

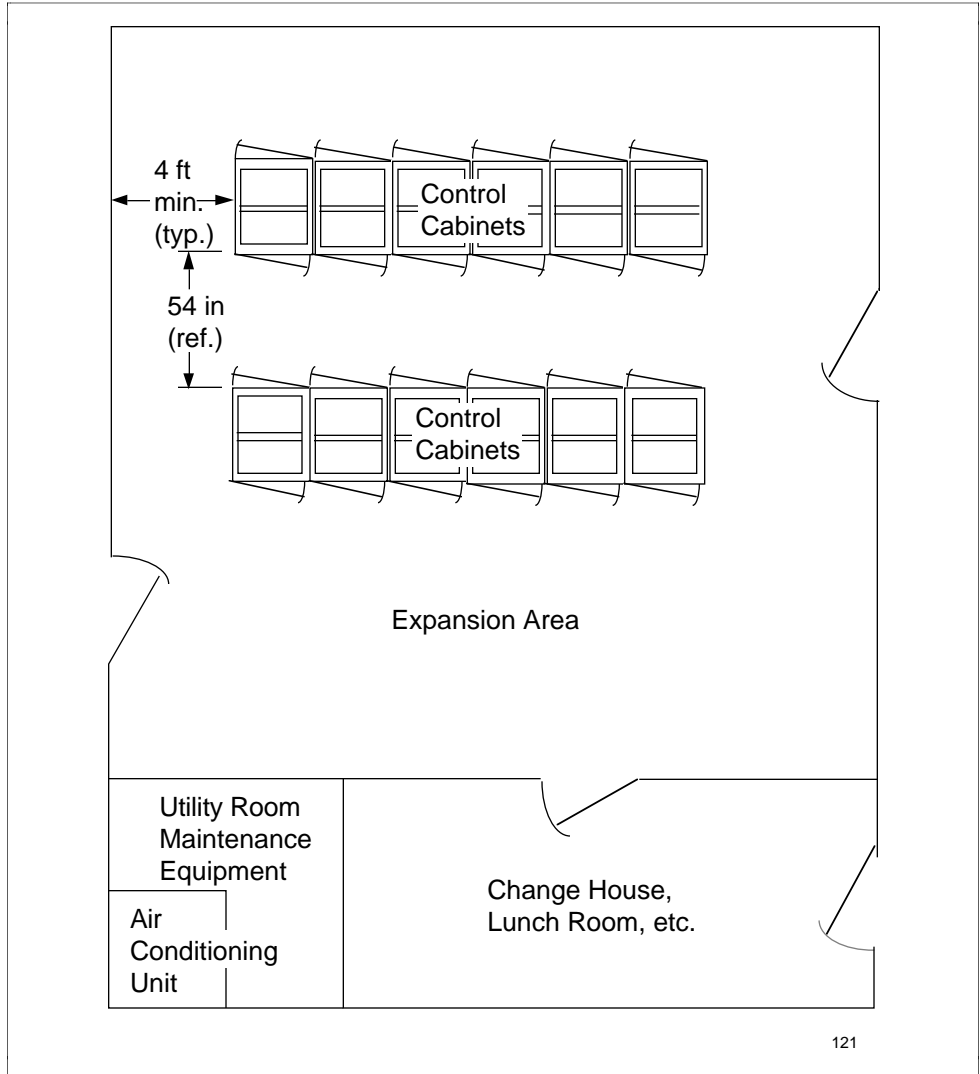

3.6 Cabinet Placement Considerations, Continued

Guidelines, continued

- Environment
 - Cabinets should be located away from doors and windows to preclude contact with rain, snow, and severe drafts.
 - Cabinets should be located upwind of dirt roads and sources of contaminants and should be away from high foot-traffic areas.
 - Cabinets should be located away from, or shielded from, sources of electromagnetic radiation.
 - Cabinet placement must be conducive to control temperature and humidity. (Refer to Appendix B for input power and heat dissipation data.)
 - Alarm system must be provided for out-of-limits temperature and humidity.
 - Visibility—Operator controls and indicators should be placed so that operators and test/maintenance technicians can readily monitor process operations.
 - Expansion—Growth potential requires consideration in the initial design stage. Ensure that the cabinet-placement plan includes room for additional equipment to be moved, installed, and serviced.
-

Section 4 – Wiring Considerations

4.1 Overview

Section contents

These are the topics covered in this section:

	Topic	See Page
4.1	Overview.....	39
4.2	AC Power.....	41
4.3	Power Distribution.....	43
4.4	BASIC Operator Station (BOS).....	44
4.5	Local Batch Operator Station (LBOS).....	47
4.6	Uninterruptible Power System.....	49
4.7	Input/Output Cabinets.....	50
4.8	Battery Backup.....	53
4.9	Conduit and Cable Trays.....	53
4.10	DC Power Distribution.....	54
4.11	DC Power Distribution to Input/Out Cabinets.....	56
4.12	Batch Control System Power Distribution.....	57
4.13	Controller File to Terminal Panel Voltage Drop.....	58
4.14	Marshalling Systems.....	59
4.15	System Interconnections.....	60
4.16	50-Conductor Cables.....	61
4.17	25-Conductor Cables.....	62
4.18	56-Conductor Cables.....	63
4.19	C-Link Communications Cables.....	64
4.20	Multiconductor Cable Routing.....	66
4.21	Signal Wiring.....	67
4.22	Potential Noise Sources.....	69
4.23	Methods of Signal Protection.....	70
4.24	Impedance Coupling.....	71
4.25	Bonding.....	73
4.26	Signal Cable and Connection.....	74
4.27	Data Hiway Cable System.....	76
4.28	Approved Data Hiway Cable.....	77
4.29	Cable Installation.....	78
4.30	Data Hiway Cable Installation.....	79
4.31	Data Hiway Electrical Loading.....	83
4.32	Data Hiway Address Capacity/Assignments.....	83
4.33	Preferred Devices.....	85
4.34	Data Hiway Noise Shielding.....	85
4.35	Branch-Length and Polled Device-Addressing Constraints.....	86
4.36	Preferred-Device Wiring.....	93
4.37	Installing Underground Conduit.....	93
4.38	Purging Conduit.....	94
4.39	Intrinsically Safe Wiring.....	95

Continued on next page

4.1 Overview, Continued

Scope

In planning for the wiring of the Honeywell TDC 3000 BASIC System, the three major considerations are power source, power distribution, and interconnection of devices.

This section covers the following:

- AC Power
- DC Power
- Cable Interconnections
- Data Hiway
- Intrinsic Safety

For both the operating area and input/output area, install all wiring in accordance with API RP550, *Manual on Installation of Refinery Instrument and Control Systems* or other equivalent industry standard.

4.2 AC Power

Base Power

The base power is 120/240 Vac, single-phase. Its major function is to energize 24 power supplies for operating the system components. The ac power is also used to energize the Operator Station, recorders, printers, and other peripheral equipment.

Power source

The selected power source must have adequate capacity to cover both present needs and possible future expansion.

The power source must be within the limits in the following table:

Table 4-1 AC Power Source

Power Source	Voltage Range	Frequency Range
100 Vac/60 Hz 100 Vac/50 Hz	90 to 120 Vac 90 to 120 Vac	60 ± 0.5 Hz 60 ± 0.5 Hz
120 Vac/60 Hz 120 Vac/50 Hz	108 to 127 Vac 108 to 127 Vac	60 ± 0.5 Hz 60 ± 0.5 Hz
220 Vac/60 Hz 220 Vac/50 Hz	198 to 242 Vac 198 to 242 Vac	60 ± 0.5 Hz 60 ± 0.5 Hz
240 Vac/60 Hz 240 Vac/50 Hz	216 to 264 Vac 216 to 264 Vac	60 ± 0.5 Hz 60 ± 0.5 Hz
Total Harmonic Distortion = 5% maximum		

Guidelines

The following guidelines must be adhered to:

- The ac branch should be independent of all other loads, especially when switching loads are involved.
- The ac branch should not provide power for air conditioning, convenience outlets, lighting, or other office equipment.
- If electrical isolation is desired, a separate transformer (Figure 4-1) can be used to supply service to the system.
- For additional noise and transient rejection, shielded primary and secondary windings can be used.
- If necessary, power-line filters can be added to attenuate noise signals that have a higher frequency than the specified power-line frequency.
- If a computer is part of your system, specific power-distribution wiring and grounding techniques are necessary to avoid excessive noise.

Refer to the computer vendor's installation, wiring, and grounding instructions. For total ac power requirements, tabulate the ac devices, and refer to Appendix B for the individual power requirements.

Continued on next page

4.2 AC Power, Continued

Guidelines,
continued

Figure 4-1 AC Power Source

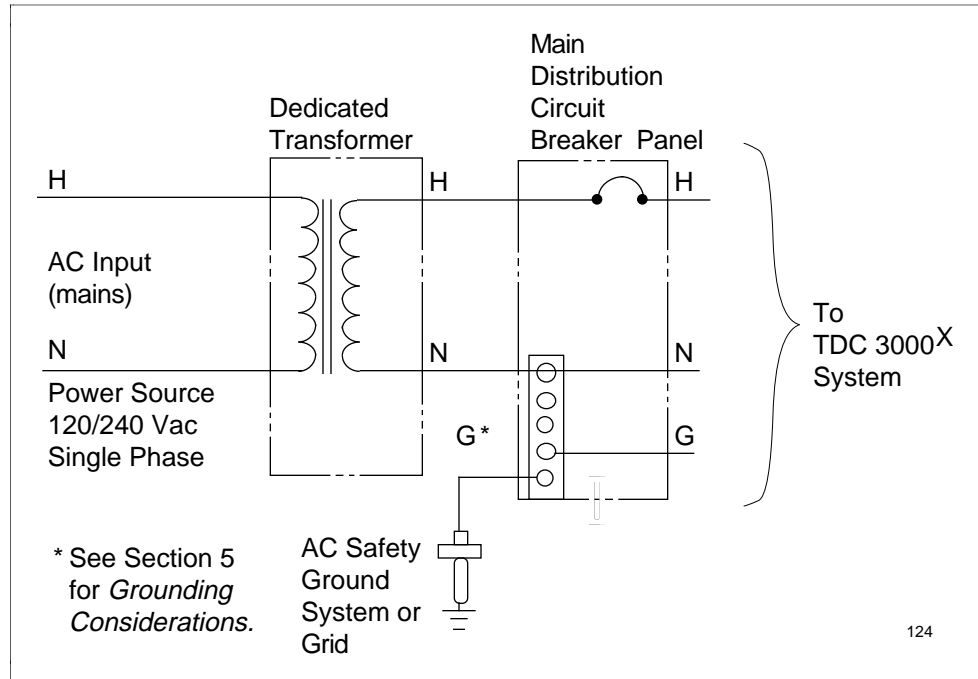

4.3 Power Distribution

Guidelines

The following must be adhered to:

- To minimize disturbance of system operation when servicing equipment, each power supply should have its own circuit breaker for ac input power.
 - Do not connect neutral (white) and ground (green) wires in the breaker boxes. If the breaker boxes are supplied with the neutral and ground connected together, remove the connector. Neutral and ground must be connected only at the service entrance panel.
-

4.4 BASIC Operator Station (BOS)

Description

Each BASIC operator station has an ac-powered dc power supply.

- A circuit breaker mounted on the front of the power supply protects internal circuits.
- It is necessary to connect only ac power to terminal block TB6 on the power-supply assembly (see Figure 4-2).
- Nominal power is 105, 115, 220, or 240 Vac. Refer to order-approval documentation for the requirements of your order.
- The operator station is normally manufactured for 115 Vac, 60 Hz input power.
- If input voltages other than 115 Vac are to be used, an external transformer can be supplied by the user, or the taps on the power-supply unit can be changed to accommodate a different voltage and/or frequency.
- Special CRT-monitor modifications must also be made before operating the unit.
- Internal power-supply-tap changes required to convert operator-station power to other than 115 Vac are outlined in Cabling, Wiring, and Interconnection document. Consult your Honeywell service representation for necessary modifications to the CRT unit.

Figure 4-2 illustrates how power is supplied when the circuit-protection panel is separately mounted.

- The green wire in the breaker-panel box must be connected to the cabinet's safety-ground terminal block.

Figure 4-3 illustrates how power is supplied when the circuit-protection panel is mounted in a cabinet section by Honeywell.

- The green wire connection in the box is connected to a safety-ground box (console frame). See SY-20-03 for Wire Routing Practices.

Continued on next page

4.4 BASIC Operator Station (BOS), Continued

Description,
continued

Figure 4-2 Basic Operator Station with Remote AC Panel

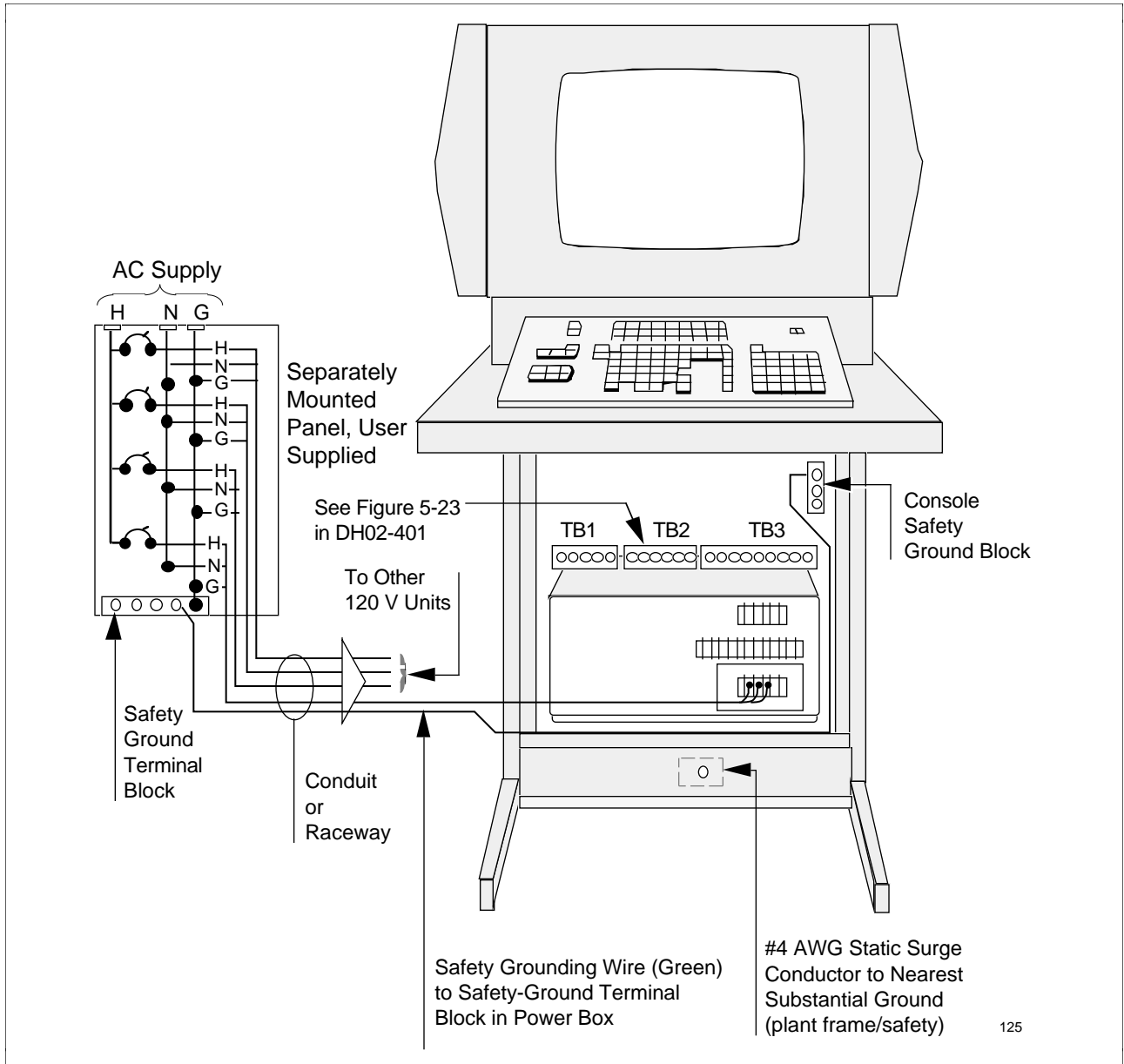

Continued on next page

4.4 BASIC Operator Station (BOS), Continued

Description,
continued

Figure 4-3 Console with Integral Breaker Panel

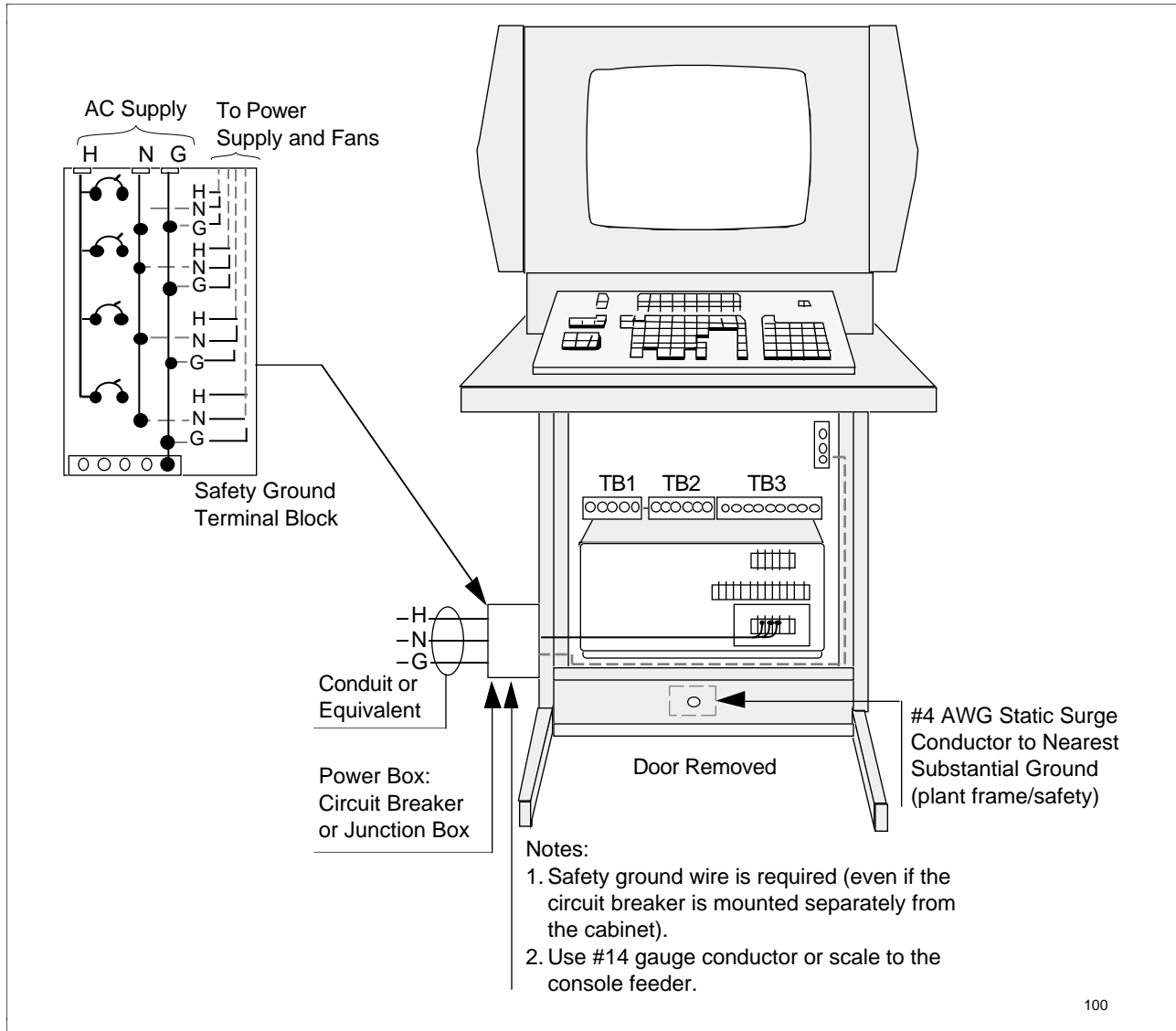

100

4.5 Local Batch Operator Station (LBOS)

Description,
continued

The LBOS can include its own dc power supply, or it can derive dc power from a source external to the LBOS.

- If the LBOS includes its own dc power supply, it is necessary only to connect Master Reference to logic common (LC) on the LBOS backpanel (refer to Section 5) and to plug the LBOS power cord into a properly configured ac receptacle.
- The ac receptacle can be mounted inside the base cabinet or desk that supports the LBOS (see Figure 4-4), or it can be mounted elsewhere. In either case, the receptacle must be mounted in a grounded metal box.
- Neither the receptacle box nor the ac circuit breaker that supplies power to the LBOS should be shared with any electrical device other than the printer that is associated with the LBOS.
- Power conductors between the circuit breaker box and the receptacle box must be routed through conduit or cable trays in accordance with the appropriate codes.
- The LBOS retains its database in the event of momentary (up to 20 milliseconds) ac power loss. To preclude longer outages (and consequent loss of database) Honeywell recommends the use of an Uninterruptible Power System or a Battery Backup System. (Refer to next two headings.)
- If the LBOS does not include its own dc power supply, it is necessary to connect a logic common (LC) wire and a frame-ground (FG) wire to the LBOS backpanel and to connect the terminal lugs on the power cord to a 24 Vdc power source. (Refer to Section 5.)

Continued on next page

4.5 Local Batch Operator Station (LBOS), Continued

Description,
continued

Figure 4-4 AC Wiring to LBOS Console

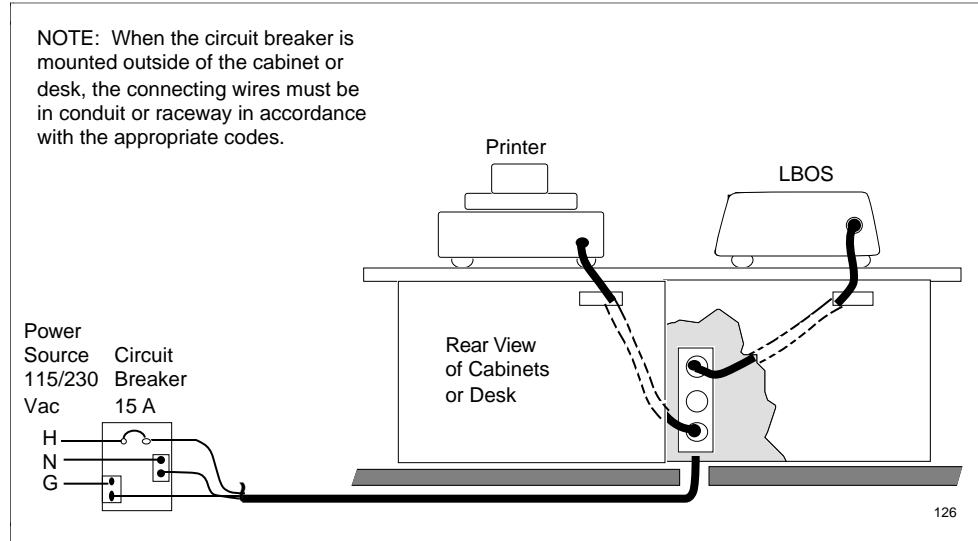

4.6 Uninterruptible Power System

Description

The optional Uninterruptible Power System (UPS) supplies ac power to operator stations during brownouts, short-term transients, and interruptions in the ac power source.

- During normal operation, ac is supplied through the UPS, and batteries are maintained at full charge. During an ac power failure, the dc battery power is converted to ac by an inverter.
- The Uninterruptible Power System requires a 15-ampere protection circuit similar to those shown in Figures 4-5 and 4-6.
- Separate uninterruptible power supplies are recommended for each operator station.
- Uninterruptible power supplies can be mounted in a standard Honeywell cabinet. Depending on the battery bank used, the back-up time can vary from 25 minutes to several hours. Larger units can be supplied as desired.

NOTE: Be sure that battery power is turned OFF during a normal or emergency plant shutdown.

4.7 Input/Output Cabinets

Description

AC power is required in the input/output cabinets to energize power supplies, operate fans, and power peripherals.

- Figure 4-5 illustrates how power is supplied when the circuit-breaker panel is separately mounted.
 - Figure 4-6 illustrates how power is supplied when the circuit-breaker panel is mounted in a cabinet section by Honeywell.
 - For either separate mounting or cabinet mounting of the circuit-breaker panel, redundant safety grounding is available as an option.
 - To provide redundant safety grounding, connect the green wire in the breaker panel box to the safety grounding lug in the bottom of any cabinet in a single or multiple cabinet assembly.
 - See SY-20-03 for Wire Routing Practices.
-

Continued on next page

4.7 Input/Output Cabinets, Continued

Description,
continued

Figure 4-5 Routing of AC Power Wiring from Separate Breaker Panel

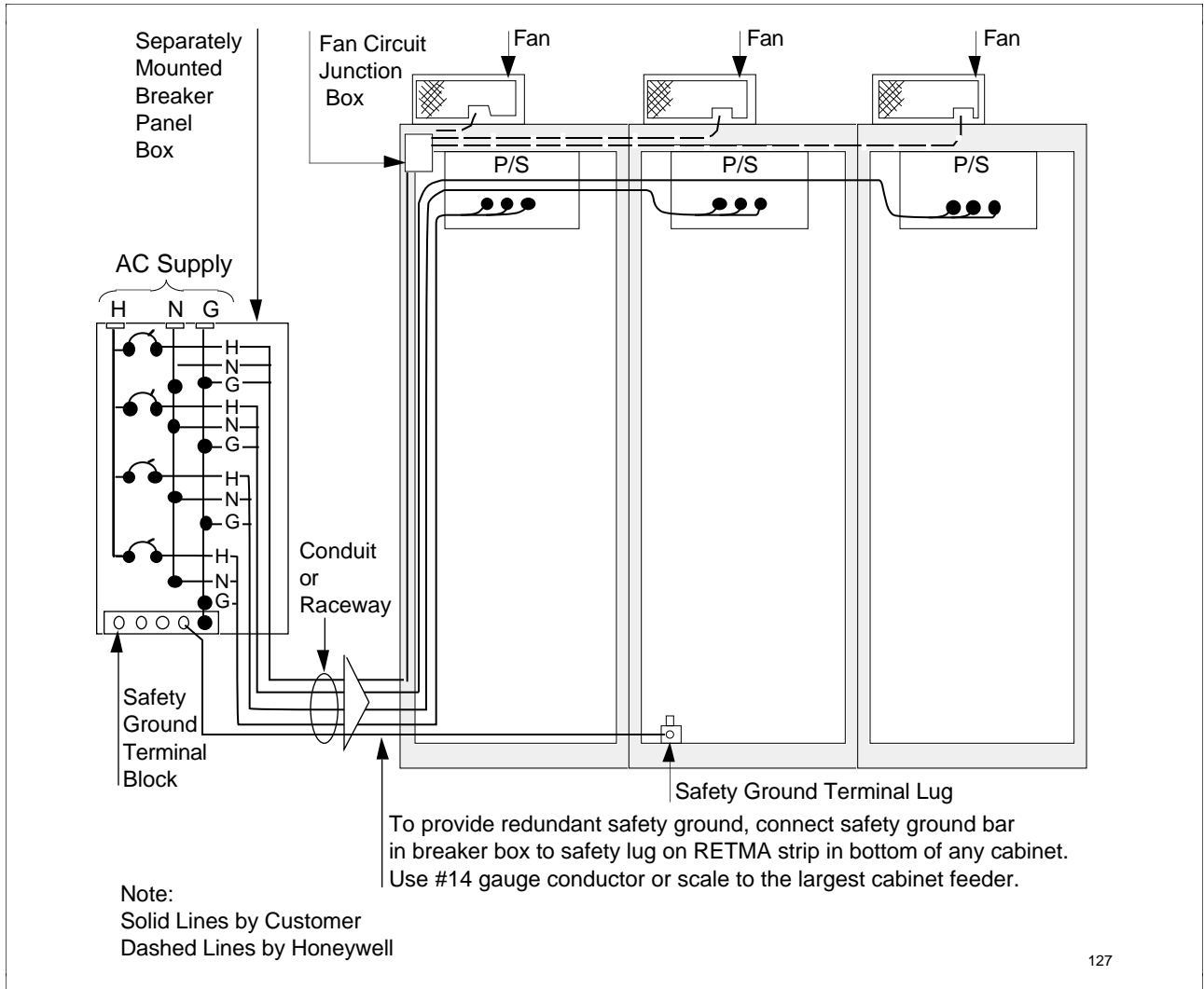

Continued on next page

4.7 Input/Output Cabinets, Continued

Description, continued

Figure 4-6 Routing of AC Power Wiring from Cabinet-Mounted Power Boxes, either Circuit Breaker Panels or Junction Boxes

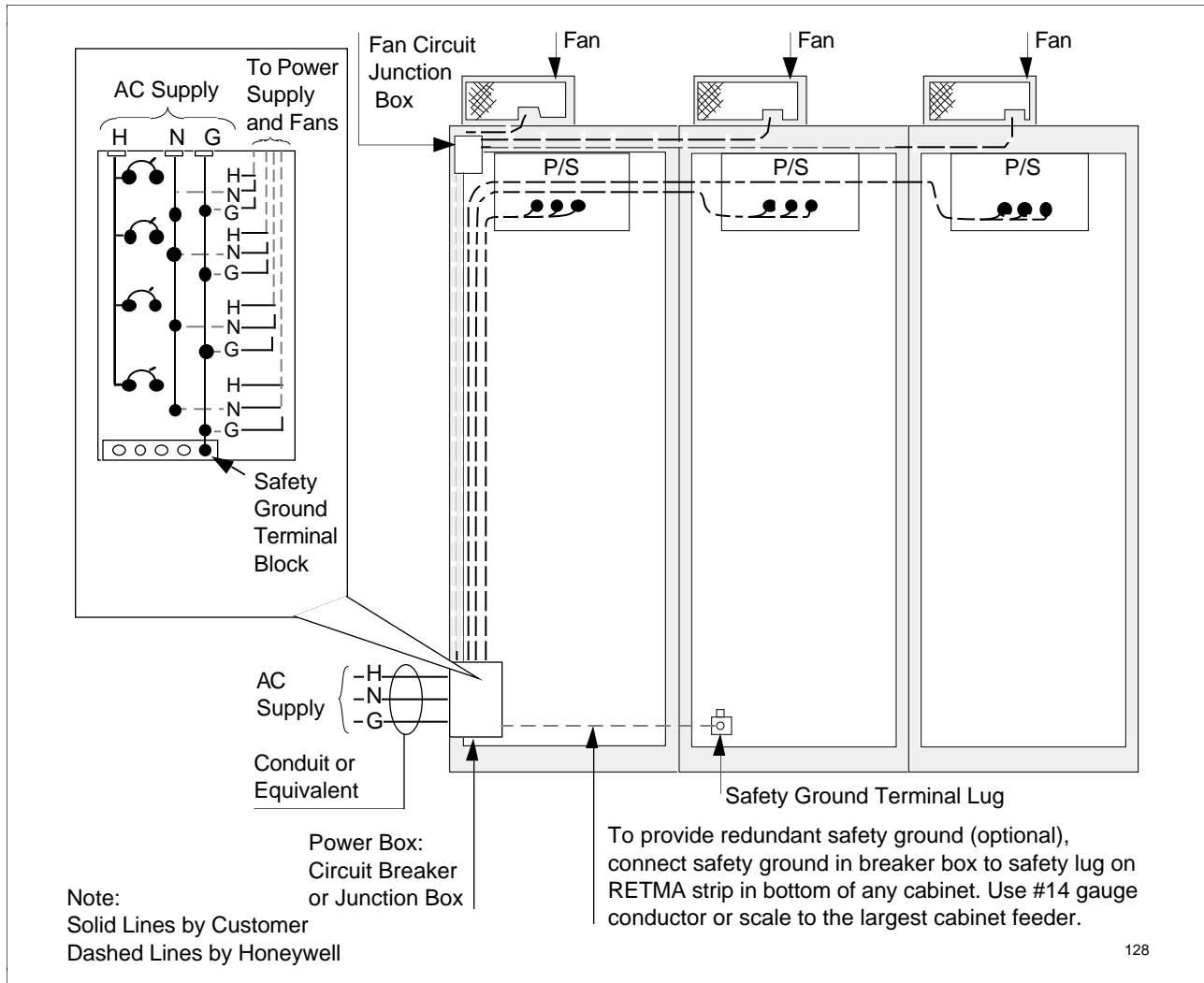

4.8 Battery Backup

Description

The optional battery backup system can supply 24 Vdc power to the busbar system during an ac or dc power failure. During standby operation, ac power is required to maintain the battery charge.

- The battery backup system is normally factory installed in its appropriate cabinet. It does require a 15-ampere protection circuit similar to those shown in Figures 4-4 and 4-5.
 - Operating time is 30 minutes, with two series connected SAE size 24 or 74 sealed lead-calcium batteries into a 40-ampere bad.
 - For ac power requirements, refer to Appendix B.
-

4.9 Conduit and Cable Trays

Requirements

The following are required:

- Use conduit or a wire tray to protect all ac power wire between the source and the distribution points and the cabinets.
 - Do not run signal wires and ac wires in the same conduit or wire tray.
-

4.10 DC Power Distribution

Description

The +24 Vdc power is distributed to the BASIC System by parallel branch power-circuits.

- Each branch circuit has a maximum load capacity of 40 amperes, plus 20 amperes of redundant power.
- Power for each branch power-circuit is distributed to BASIC equipment through a bus-bar system consisting of a +24 Vdc bus, a Power Supply Common (PSC) bus, and a Signal Common (SC) bus (see Figure 4-7).
- When selecting the load for each branch power-circuit, all devices that require power must be considered.
- Do not load each branch power circuit with 40 amperes because this would not permit future changes.

Figure 4-7 DC Power and Bus Bar System

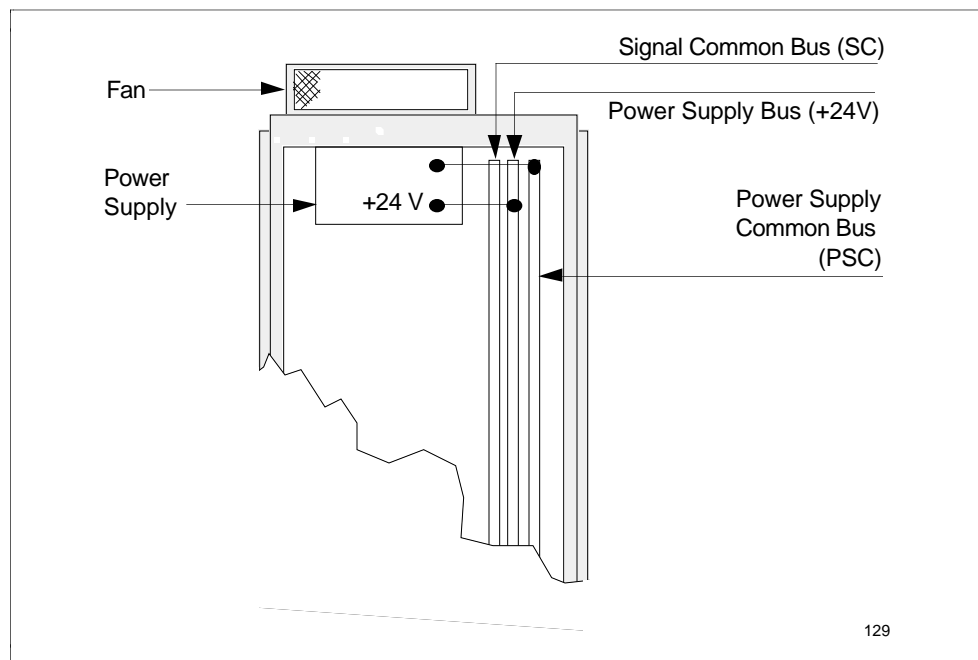

Continued on next page

4.10 DC Power Distribution, Continued

Example

To illustrate how to calculate a load for a branch power-circuit, we will consider only the controllers. The current requirements of the controllers are as follows:

Name	Ampere
Basic Controller File	2.5
Basic Controller File and Data Hiway Interface	3.50
Basic Controller File + Data Hiway Interface + Trend Memory	4.00

In addition, each field transmitter and final-control element associated with the controller receives power from the controller's terminal panel. The total power consumption, therefore, could be as high as follows:

Name	Ampere
Controller File with Hiway Interface Cards and Trend Memory	3.75 amps max.
16 Xmtr inputs and 8 analog outputs (24 x 0.020 amps = 0.48 amps)	0.5 amps max.
Total power consumption	4.25 amps max.

With six (maximum) controller files that should be loaded onto a dc branch, power circuit would then be

$$(6 \times 4.25 = 25.5 \text{ amps}) = \text{six controllers}$$

This leaves approximately 35% (14.5 amps) spare capacity to accommodate optional equipment such as relays and auxiliaries.

4.11 DC Power Distribution to Input/Out Cabinets

Power bus bar

In the I/O cabinet area, power from the dc power supplies is connected to the bus-bar system for distribution to files and terminal panels as illustrated by Figure 4-6.

- The dc is used to power controllers, auxiliaries, analog units, and terminal panels that are connected to the bus-bar system.
- Analog displays and transmitters connected to the terminal panel are also operated by the 24 Vdc supply.
- File and device power returns through the Power Supply Common (PSC) bus, and signals return through the Signal Common (SC) bus.

NOTE: HLPIUs and LLPIUs do not always use a bus-bar system. See Section 5, Figure 5-19 for grounding connections.

4.12 Batch Control System Power Distribution

Example

The method of calculating a maximum power load for a branch in a Batch Control System is illustrated in the following example.

- Suppose that a single branch (40 amperes maximum) feeds two 20 amp. circuit breakers, one mounted on each side of a panel in a cabinet.
- Two Multifunction Controllers, mounted back-to-back on the panel, each consist of:
 - 1 Controller File with Data Hiway Interface
 - 1 Controller File Terminal Panel
 - 2 Point Card Files (PC100), each with 8 Digital Output cards (XOD31)
 - 8 Digital Output Displays (LEM01)
(4 on each Point Card File)

Using data in Appendix B to calculate the maximum load for each Batch Controller yields:

Type	Load
Controller File (w/o Data Hiway Interface)	2.46 A
Data Hiway Interface	0.75 A
Controller File Terminal Panel	0.48 A
Point Card Files (2 @ 0.60 A)	1.20 A
Digital Output Cards (16 @ 0.41 A)	6.56 A
Digital Displays (8 @ 0.34 A)	2.72 A
Total/Batch Controller	14.17 A

- Then the branch will draw $(14.17) \times 2 = 28.34$ amperes.
- Because the branch is capable of carrying 40 amperes, this leaves
 - $40 \text{ A} - 28.34 \text{ A} = 11.66$ amperes

$$\text{(Or } \frac{11.66}{40} = 29\%)$$

additional capacity to power relays, auxiliaries, and any other additional equipment.

4.13 Controller File to Terminal Panel Voltage Drop

Example

Controller files and their TCBX0 panels can be mounted in separate cabinets with a maximum separation dictated by the length of interconnecting signal cabling (200 ft.).

The voltage drop in the 24-volt return ground connections must be:

1. Less than 200 mV between a controller file and its associated controller terminal panel (TCBX0) to ensure that the remote-sensing feature built into the controller file's A/D circuitry functions reliably.
2. Less than 4 mV between a TCBX0 panel and any input source such as a zener-barrier panel (TBU10) that is a signal source for the TCBX0 panel to maintain signal accuracy.
3. Less than 4 mV between the TCBX0 panel associated with a reserve controller file and all TCBX0 panels associated with the backed-up controllers in a UAC system to ensure signal integrity.

Often, 24 Vdc power is carried through ground wiring between the controller files and their associated panels. Wire must be of a diameter that ensures that the IR drop does not exceed 200 mV or 4 mV as specified above.

Wire Size

To determine the size of wiring required to ensure that the IR drop is less than 200 mV (as specified in 1 above), use the data in Table 5-2. To ensure that IR drops of less than 4 mV (required as specified in 2 and 3 above), appropriately select conductors (including auxiliary bus bars).

IR drop

The IR drop between a given controller file and its associated TCBX0 panel, TBU10 panels, and 24 Vdc power supply can be minimized by mounting all these components in a single or multiunit cabinet and directly connecting their 24 Vdc returns to the power-supply common (PSC) bus bar in that cabinet.

Reference Documents

Refer to:

- Section 5 of Site Planning Manual
 - Power System Guidelines, SY-20-03
-

4.14 Marshalling Systems

Description

Marshalling is the gathering of circuits into a methodical arrangement. A single panel can be used to organize circuits in a local area or they can be channeled through multiconductor cable to and from other terminals in a distant area.

- General marshalling panel C-TPG00 is used for local marshalling of circuits and for distribution of power to counter coils, alarm relays, etc.
 - Local marshalling panel C-TPM02 gathers and distributes circuits in the terminal area. Cable-connected panel C-TBM01 gathers and distributes signals in a remote area.
 - Two C-TPM02 panels connected by two multiconductor cables form a 64-wire extension cord with screw terminals at each end.
 - Do not use these systems in wiring between the zener barriers and the field devices.
-

Reference Documents

Refer to:

- Section 5 of Site Planning Manual, Marshalling Systems—Cabling, Wiring, and Interconnection, T0-20-02.
-

4.15 System Interconnections

Plug-in cables

Files (Controller, Reserve Controller, Point Card, Analog Unit, and Auxiliaries), associated terminal panels, junction panels, analog displays, digital display, Data Entry Panels (DEP), Local Batch Operator Stations (LBOS), recorders, standby manual, and marshalling panels are interconnected by plug-in multiconductor cables.

4.16 50-Conductor Cables

Description

The 50-conductor cables (Figure 4-8) (25 twisted pairs) have a male, series 57, Amphenol connector on each end. Conductors are 24 AWG with a resistance of 6 ohms per 60 meters (200 ft).

The cable OD is 11 mm (0.44 in). The cable weighs 170 g/m (2 oz/ft). Cables are available as tabulated:

Table 4-2 50-Conductor Cables

Length		Model Number
Meters	Feet	
1	3.3	KD001
1.5	5.0	KD901
2	6.6	KD902
3	9.8	KD003
5	16.4	KD005
8	26.3	KD008
15	49.2	KD015
30	98.4	KD030
45	147.7	KD045
60	197.0	KD060

Cable splice C-KD000 is available for connecting two cables.

Cables connect to female, series 57, Amphenol receptacles on DEPs, controller files, terminal panels, junction panels, and displays. Cables connect J1 receptacle on one device to J1 receptacle on another device; J2 on one device to J2 on another device, and so on.

Figure 4-8 50-Conductor Cable

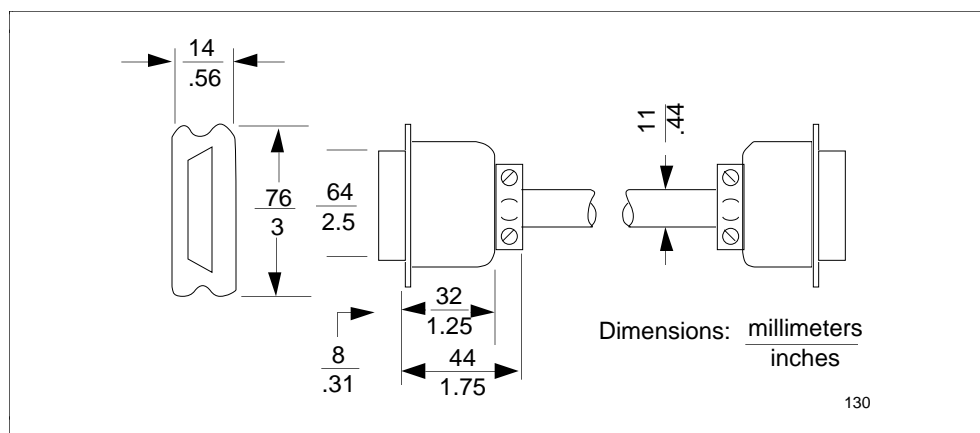

4.17 25-Conductor Cables

Description

Extended Controllers use 25 conductor miniature cables to link the digital-input junction panel to the digital-input DEP interface (DIDEP) card in the controller file. Cables are available as tabulated:

Table 4-3 25-Conductor Cables

Length		Model Number
Meters	Feet	
1.25	4.1	KDP01
2	6.6	KDP02
3	9.8	KDP03
5	16.4	KDP05
8	26.3	KDP08

Cables are 28 AWG and are equipped with a male connector on each end. Cables are connected to female receptacles on the DIDEPI card and digital-input junction panel.

4.18 56-Conductor Cables

Description

The Batch System uses 56-conductor cables (Figure 4-9) for interconnecting point-card files with point card terminal panels, digital-display junction panels, and digital displays. These cables are equipped with an ELCO series 8016 rectangular male connector on each end and a shield ground wire that must be connected to the terminal and/or junction panel.

Table 4-4 56-Conductor Cables

Length		Model Number
Meters	Feet	
1	3	KE001
1.5	5	KE115
2	6	KE002
3	10	KE003
8	26	KE008

Figure 4-9 56-Conductor Cable

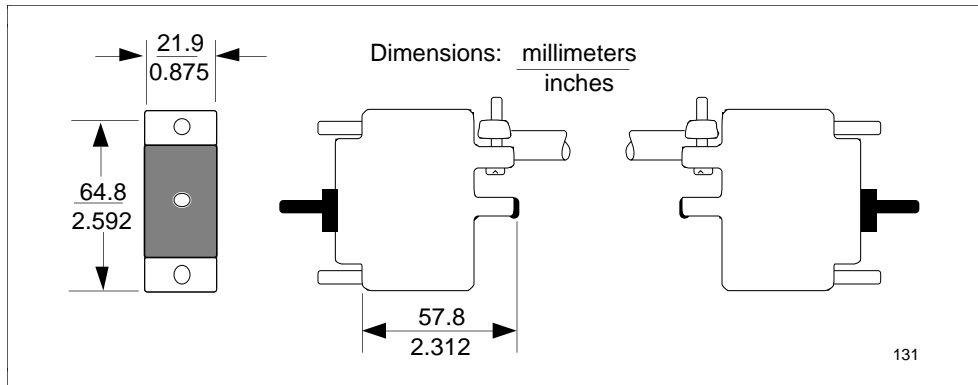

4.19 C-Link Communications Cables

Description

The Batch Control System data transmission cabling consists of redundant cables (Channel A and Channel B) that interconnect the system components. These cables are referred to as the C-Link hookup between the LBOS and the controller files.

- One controller file uses one or two point-card files, and up to eight controller files and their associated point-card files can be connected to a C-Link network.
- C-Link cables are available as tabulated in Table 4-4.
- C-Link cables can be run up to 100 m (325 ft.) away, and should be mechanically protected by conduit, cable tray, or floor troughs.
- How the C-Link cable assemblies are used is illustrated as Examples A and B in Figure 4-9.
 - the files are daisy-chained together and wired to the adapter boxes.
 - the cabinet is then connected to the next cabinet or to an LBOS by outside cable KREXX.
 - the XX= length to be determined by the user at the time the layout is made. Consult Table 4-4 for standard cable.
- For intrinsically safe applications, the J-DCLX0 fiber optic-type energy limiter is used in the C-Link to electrically isolate the controller file(s) from the LBOS.
- The J-DCLX0 fiber optic-type energy limiter can also be used to extend the maximum distance of the C-Link cable to 200 meters (656 ft) by locating the limiter box at the center of the C-Link run. Refer to SY-09-04, *Cabling, Wiring, and Interconnection* publication for installation procedures.

Table 4-5 C-Link Communications Cables

Length		Model Number	Type
Meters	Feet		
2 meter dual	6-7 ft	KRS20	Unshielded 10-conductor flat ribbon cable
1.5 + 0.5 meter dual	4-7 ft	KRL20	Unshielded 10-conductor flat ribbon cable
Extra Single XX = length in meters		KREXX	Shielded twisted pair

Continued on next page

4.19 C-Link Communications Cables, Continued

Description,
continued

Figure 4-10 C-Link Cabinet Cable Assembly

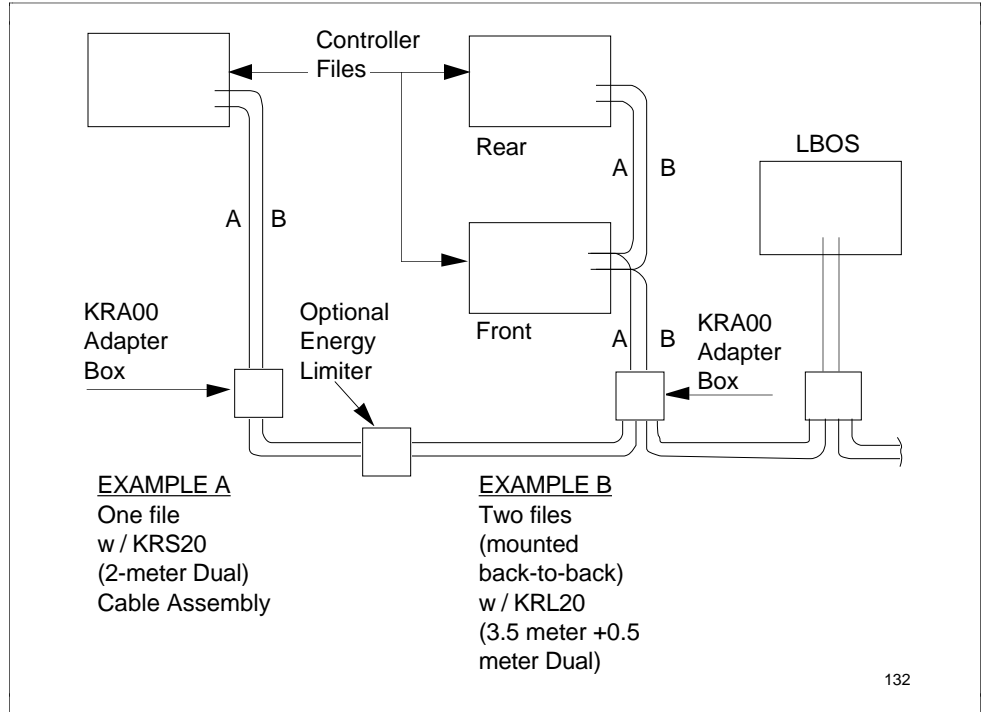

4.20 Multiconductor Cable Routing

Guidelines

When connecting TDC 3000 devices in separately mounted cabinets with multiconductor cables make sure that:

- cables are supported on tray or shelf
- cables are clamped to cabinet frame near connector to prevent any strain on conductor or receptacle.
- you do not pull cables through conduit because of the large connectors on each end (see Figure 4-7 and 4-8).

For specific details on interconnecting multiconductor cables, refer to the following documents:

Publication	Publication Number
Basic Control Systems	SY-20-01
Analog Unit System	CA-20-01
Display System	LO-20-03
Marshalling Systems	TO-20-02
Reserve Controller Systems	CB-20-02
Standby Manual (4-Element)	LO-20-02
Process Interface Unit	PI-09-01
Extended Uninterruptible Automatic Control System	CD-09-05
Batch Control System	SY-09-04

4.21 Signal Wiring

Field wire connections

Process interface wiring can be terminated as follows:

- Controllers, Analog Units, Analog Displays, Digital Displays, Reserve Controllers, and Marshalling Systems interface with the process at terminal panels in the I/O area.
 - These terminal panels can be in cabinets with the controllers or in separate cabinets.
 - HLPIUs and LLPIUs interface with the process at terminals in the I/O area. These terminal panels are in the cabinets with the PIU files.
 - LEPIUs interface at terminals in the MUX-interface boxes that are conveniently located in the process area. These boxes are connected to the common card-file assembly (CCFA) in the I/O area with up to three 1.67 mm (No. 14 AWG) shielded twisted pairs.
 - Up to 16 MUX boxes can be connected (redial, daisy-chain, or any combination of each). Refer to Appendix A for cable lengths and wiring arrangements.
-

Screw terminals

All screw terminals are capable of accepting two 1.67 mm (No. 14 AWG) wires. The maximum acceptable size is 2.12 mm (No. 12 AWG).

Signal types

To describe process connections, we have categorized them as inputs and outputs:

- outputs go from the system to the process
 - output signals are typically sensed by devices that are less accurate and have a slower response than the device that output the signal.
 - inputs come from the process to the system
-

Guidelines

The following guidelines apply to input signals and output signals.

- Input signals can be analog or digital.
- While analog-input voltage and current vary according to the type of receiver, they should be classified as low-level or high-level signals.
- Low-level signals, such as those generated by a thermocouple, require greater noise protection than transmitter signals.
- Digital input signals operate at various voltage levels, depending on the signal-source power supply.

When a specified wire exceeds capacity of a screw terminal, a 14-gauge pigtail crimped to the larger wire can be used. Figure 4-11 illustrates the C-Link network in a data-communications chain and the relationship between controller files and point card files.

Continued on next page

4.21 Signal Wiring, Continued

Illustration

Figure 4-11 C-Link Communications Network

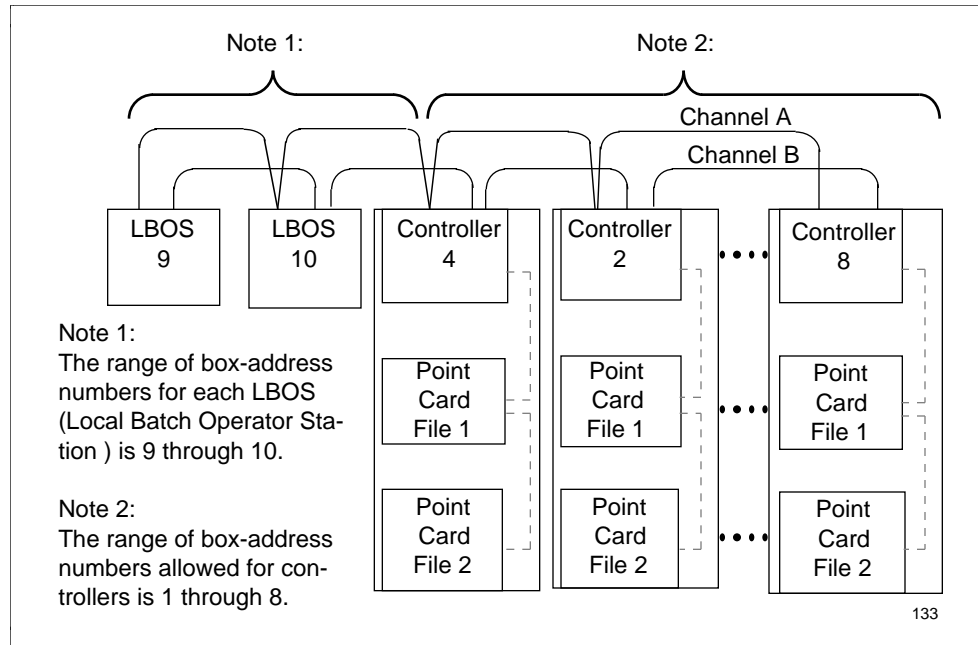

4.22 Potential Noise Sources

Description

Noise can be coupled in one of three ways:

- Capacitive or electrostatic
- Inductive or magnetic
- Impedance

Capacitive and inductive coupling have the same essential effect— they permit the effect of current or voltage changes in one circuit to be felt in another circuit without any actual connection of the two. Impedance coupling requires a connection between circuits. The following are typical examples of noise-generating devices that could affect the signal wires through capacitive and inductive coupling:

- Relay coils
- Solenoids
- AC power wires, especially above 120 Vac
- Thyristor field exciters
- Power feeders to electric arc furnaces
- Current-carrying cables

Impedance coupling can become a problem where a low-level signal is referenced to the same common as other circuits, which dumps noise into the common circuit. Methods for protection against these types of noise coupling are discussed later in this section.

Signal cables as potential noise sources

Signal cables carrying noisy signals can act as potential noise sources to other signal cables routed near them. A full study of noise problems should include such factors as signal rate-of-rise, signal level, length of cable exposure, and circuit impedances. When possible, cable specialists should be consulted to analyze the actual equipment involved.

4.23 Methods of Signal Protection

Guidelines

Impedance coupling can be prevented by

- using large diameter wire or bus for the common lead, especially when shared with other circuits.
- using separate common leads to the ground stake.
- using separate signal common ground stakes.

Capacitive and inductive coupled noise appears on signal wires at levels proportional to the strength of the originating circuit, the proximity of the two circuits involved, and the length of exposed cable.

Noise suppression

Suppression of noise at the source is always desirable, but it may be impossible in some cases owing to the size of components required. Individual decisions must be made for noise suppression and filtering, based upon the extent of the problem. The use of a diode across a relay solenoid is an example of suppression technique.

*Also see “Wire Shield Grounds” in Section 5.

4.24 Impedance Coupling Prevention

Guidelines

With the exception of digital signals greater than 30 Vdc, all TDC 3000^X system signals are mutually tolerant; hence, conductors for 4-20 mA signals, 1-5 V signals, all 25-, 50- and 56-conductor cables, the C-Link, the Data Hiway, and all TDC Master Reference Ground wires can be routed through the same cable trays or conduits.

The same trays or conduits that are used for the above-mentioned conductors can also be used for

- 24-30 Vdc or equivalent ac digital signals if conductors are in twisted, shielded pairs.
- LEPIU cables, if common-mode inputs are less than 30 V peak.
- thermocouple and millivolt wires for PIUs and auxiliaries.

Separate trays, separate conduits, or separate compartments (with grounded steel barriers) in trays should be provided for conductors for

- other low-level devices, such as thermocouple scanners.
- digital outputs higher than 30 V peak (as from interposing relay panels).

When it is necessary to route cabling of dissimilar signal types, the following should be employed:

- Group cables according to signal level types. For example, low level analog signals should be grouped in trays or conduits separate from all other signal types.
- When separate trays or conduits are impractical, trays with compartments separated by grounded steel barriers can be used to isolate conductors of different signal types. Separate compartments should be provided for millivolt signals, 1-5 volts signals, digital (24-30 Vdc or equivalent peak voltage) signals, relay-type thermocouple scanner signals, and non-Honeywell hiway signals.

ATTENTION

The use of tray compartments is not as effective as the use of separate trays or conduits. It may be necessary to reroute some cables after installation.

- When unlike signals must cross, either in trays or conduits, they should cross at a 90-degree angle and at maximum spacing. Where it is not possible to provide spacing, a tray cover should be placed between unlike levels at the crossover points.
- Trays containing low-level wiring should have solid metal bottoms and sides. Tray covers must be used. Tray-cover contact with side rails must be positive and continuous to avoid high-reluctance air gaps. Trays for low-level cables should be metal and solidly grounded. (Refer to Bonding, the next heading.)
- Trays and conduits containing low level signals should not be routed near high-power equipment enclosures.

Continued on next page

4.24 Impedance Coupling Prevention, Continued

Guidelines, continued

- Enhanced Interposing Relay Panels used in Batch Control Systems have 120/240 Vac relays, hence must be
 - separated from the Data Hiway and Data Hiway devices by 12 ft (50 ft/kv), or
 - mounted in the cabinet on the side of the metal panel opposite from the Data Hiway and Data Hiway devices.

These separation rules also apply to the Local Control Network (LCN) cable and modules.

4.25 Bonding

Description

Conduits, cable trays, and raceways should be solidly connected or bonded to assure electrical continuity of an entire run. For tapered threads on conduits, properly installed conduits are considered to be bonded.

A bare copper-bonding wire is frequently installed in the tray to provide electrical continuity for proper grounding. Contact of tray covers to rails should be positive and continuous. Trays should be grounded at several points (wherever convenient) using 4 gauge or larger wire. In areas of high electrical noise, trays should be grounded at both ends and at frequent intervals to suppress propagation of magnetic fields.

4.26 Signal Cable and Connection

Description

Normal connections for the process cables are at terminal blocks or connectors on panels in the cabinets. Wire sized up to 2.12 mm (No. 12 AWG) with lug terminals can be accommodated by the screw connections.

Consideration should also be given to the overall routing requirements for all cables entering the cabinet when selecting individual cables, because overly large cables may present routing problems within the cabinet itself.

Refer to Section 5 for information on connecting cable shields.

Guidelines

The following recommended cable types are based on typical use.

Table 4-6 Low Level Analog Signal Cable Types

Signal Type	Wire Type
Thermocouples	<ul style="list-style-type: none"> The extension wires must be a material that is compatible with the thermocouple used. Polarity of the leads must be strictly observed through the run of the thermocouple circuit. Extension wire should be twisted pairs with an insulated shield. In cases where the physical layout permits multiple pair extension, a common shield should be used.
Thermal Converter Output	Individual, twisted, shielded pairs must be used for each converter, typically, 1.32 mm (No. 16 AWG).
Two-Wire Miscellaneous Low Level Signals	Individual, twisted, shielded pairs must be used for each transducer, typically, 1.32 mm (No. 16 AWG).
Resistance Temperature Device (RTD)	Triplet lead wires for each RTD input must include three twisted conductors (typically 1.32 mm or 16 AWG) in a common shield. CAUTION: All three conductors in the triplet need to be the same length to assure the required accuracy.

Continued on next page

4.26 Signal Cable and Connection, Continued

Guidelines,
continued

Table 4-7 High Level Analog Signal Cable Types

Signal Type	Wire Type
Current Signals	<ul style="list-style-type: none"> • Most transducers and transmitters of this type operate over a reasonably wide impedance range or have lead wire and load compensation potentiometers. • Twisted pairs are generally used. • Where physical layout permits, multiple pairs, typically 1.32 mm (No. 16 AWG), with an optional and common shield are practical for input and output signals.
Analytical X-Ray Gauges, Operational Amplifiers in other control equipment, and other 2 wire inputs	<ul style="list-style-type: none"> • Individual, twisted, shielded pairs are generally used. • Multiple-conductor cable can be used in cases when a large number of inputs come from one piece of equipment.

Table 4-8 Digital Input and Output Signal Cable Types

Signal Type	Wire Type
Digital Input Digital Outputs	<ul style="list-style-type: none"> • The wire and cable types for digital inputs and outputs have to be considered on the basis of each application. • The size of the individual cables depends on the current levels they are required to handle. • To control cross-talk, every digital signal-wire pair of triplet should be twisted and shielded.

4.27 Data Hiway Cable System

Overview

The TDC 3000^X Total Distributed Control System Data Hiway consists of redundant color-coded coaxial cables (Hiway A and Hiway B) that interconnect the hiway-connected devices. Cable A is color-coded red and cable B is color-coded blue. Signals on the Data Hiway are 31-bit serial data transmitted at a rate of 250 kHz. Data Hiway signals are controlled by a Hiway Traffic Director (HTD). Each Data Hiway can have up to three branches of redundant coaxial cables connected to the HTD. The HTD can be connected to either end of the Data Hiway or any place between the ends. Figure 4-12 illustrates how the branches relate to the HTD.

Figure 4-12 Data Hiway Connected Devices (Boxes)

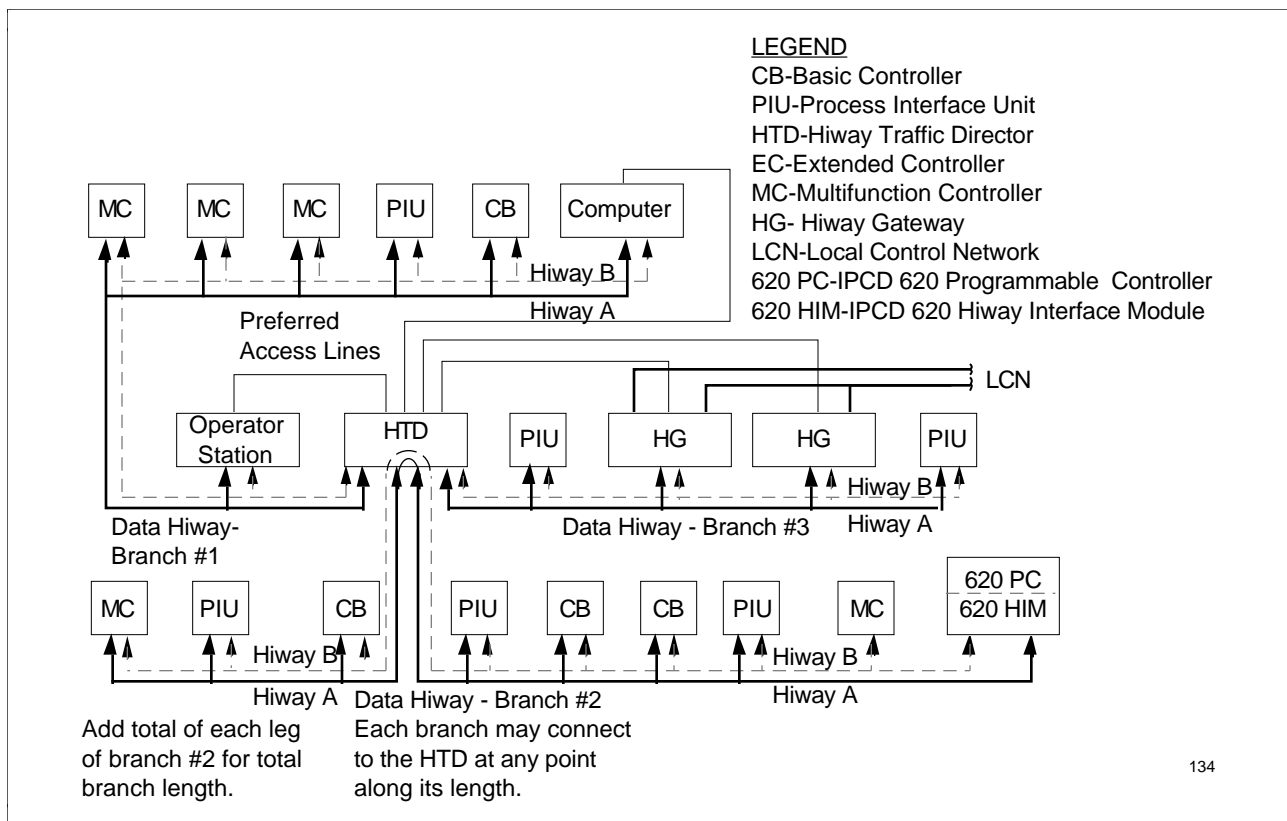

134

4.28 Approved Data Hiway Cable

Description

The following are possible cable types:

- Coaxial Cable, used where mechanical protection is available.
- Bamboo Data Hiway Cable— armored-type coaxial cable for use under difficult environmental conditions without the protection of purged conduit or cable trays.
- Fiber-optic cable, for extension of the Data Hiway into or through hazardous or electrically-noisy areas.

For data regarding Data Hiway cable applications, refer to the information under Branch Length and Polled Device Addressing Constraints, given later in this section.

Table 4-9 Approved Data Hiway Cable

Vendor	Cable Type	Comments
Belden	8213 No. 14 AWG Center Wire	If flexibility is more important than strength or rigidity, use PVC cable from a Honeywell-approved source that meets Honeywell specification 51190838-100
Times Wire & Cable	FM59—No. 20 AWG Center Wire	
NKF Kabel Waddinxveen, Netherlands	Bamboo Data Hiway Cable 3	
NKF Kabel Waddinxveen, Netherlands	Bamboo Data Hiway Cable 1.5	
Siecor	Type 244P	Fiber Optic Cable for indoor installation
Siecor	Type 2462K006001	Fiber Optic Cable for outdoor aerial installation
Siecor	Type 2462J006001	Fiber Optic Cable for outdoor direct burial

4.29 Cable Installation

Description

The Data Hiway consists of redundant color-coded cables (Hiway A and Hiway B) so that communication can be automatically switched to the second hiway if the primary one becomes defective. On the HTD display, LED A or B is on to indicate that Hiway A or Hiway B, respectively, is active. Use the following guides for cable installation:

- Separately route Hiway A and Hiway B cables to Data Hiway devices to prevent a single accident from damaging both cables.
 - Do not use the direct-burial cables in high-lightning areas when adequate plant grounding for lightning is not possible. See Section 5.
 - In well-protected areas, the cables can be run together in parallel; it does not matter if they get twisted.
 - In mechanically hazardous areas, protect the cable with conduit or wire trays.
 - Avoid short radius bends that may kink or damage the dielectric.
 - Avoid excess squeezing of the cable. The foam core may collapse causing impedance discontinuity and possible transmission errors.
 - Carefully coil any excess cable.
 - To reduce tension on BNC connectors caused by the heavy coaxial cable, the following method can be used:
 - All Data Hiway connections to BNC tees or connectors on TDC-3000^X devices must be made with No.20 AWG (small diameter) Honeywell-approved cable.
 - Field runs of No. 14 AWG cable should end at the top or bottom of a cabinet or group of cabinets.
 - At this point, a length of No. 20 AWG cable must be connected to the No. 14 AWG cable with a BNC splice-fitting model C-KCA04.
 - The other end of the No. 20 AWG cable connects to the BNC fitting on the appropriate device. This reduces tension on BNC connectors caused by the heavy coaxial cable.
 - Cover the splice-fitting with the heat-shrink insulator supplied.
-

4.30 Data Hiway Cable Installation

Coax cable

Most of the hiway devices are connected to the Data Hiway by using an L-pad packaged in a coaxial tee fitting.

- No cable should be connected between the tee and the device.
- A terminator must be put on the unused side of the last tee on the cable.
- For devices that do not require a tee but directly connect to the cable, a terminator must be put on any unused BNC connectors.
- Refer to the installation instruction for each device to determine the type of Data Hiway connection.

The HTD, like any other hiway device, can be connected to either end of the Data Hiway (see Figure 4-13) or any place in between (see Figure 4-14).

- When the HTD is at the end of a branch, the cable can be connected to either the IN or OUT BNC connector.
 - A terminator is put on each unused BNC connector.
 - The maximum length of the Data Hiway is as calculated by a formula (see *Branch Length and Polled Device Addressing Constraints*).
 - When the HTD is connected in the middle of the branch, the total maximum length is the sum of the two legs. There is no restriction on the length of each leg, provided the sum of the two does not exceed the total maximum.
 - Four preferred devices can be connected to the HTD or up to four Preferred Access Expanders (PAE). Up to 16 preferred devices can have access to the Data Hiway through the four PAEs.
 - When a Bamboo Data Hiway cable is used, a reduced fitting with a connector for a BNC fitting must be installed on each end tee, then FM59 (No. 20 AWG) is run to the TDC 3000^X device. The method used to connect Belden 8213 with tees for each device, and FM59 for the run inside the cabinets, is illustrated in Figure 4-15.
 - Do not use tee connectors on the Hiway Traffic Director (HTD) and on the computer's HIM/DHI. The coax cable must be directly connected to the BNC connectors of these two devices.
 - The ground sources for the two hiways (A & B) are connected in the HTD, but they must be electrically isolated from each other everywhere else. Be sure that they are not shorted together or accidentally grounded to the chassis frame. All tees, terminators, and splice-fittings must be covered by heat-shrink insulator.
 - Reducer assemblies require insulation (as provided in the reducer kit).
- Specify the conduit length between pull boxes so that the maximum pull force recommended by the cable manufacturer is not exceeded.
-

Continued on next page

4.30 Data Hiway Cable Installation, Continued

Examples

Figure 4-13 HTD at the End of a Branch

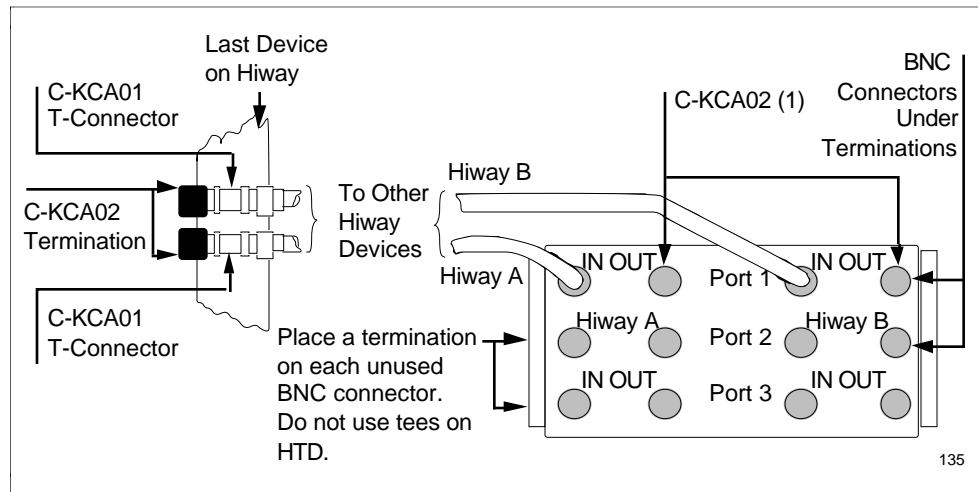
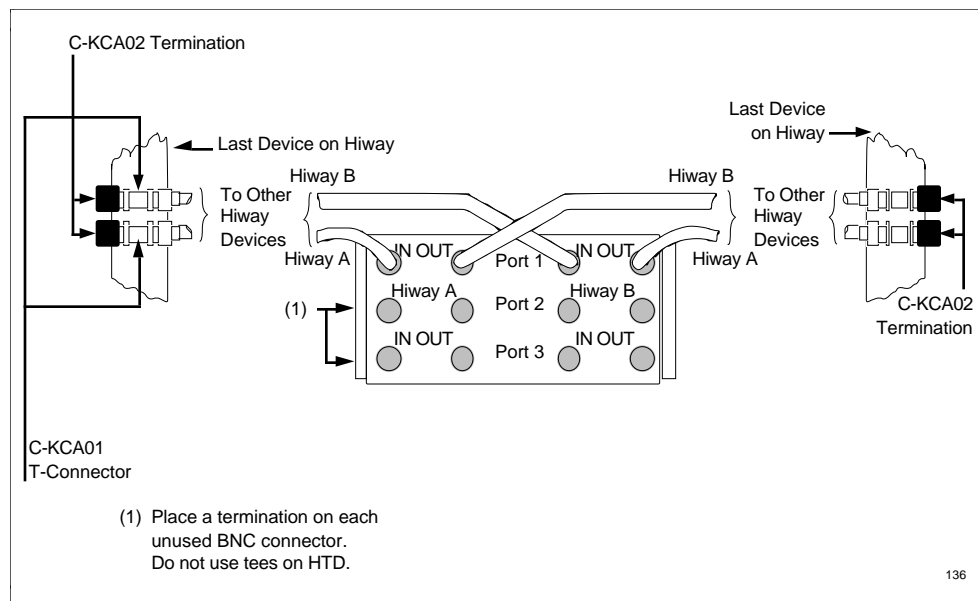

Figure 4-14 HTD Between Ends of a Branch



Continued on next page

4.30 Data Hiway Cable Installation, Continued

Example

Figure 4-15 Bamboo Hiway Cable (BHC) Connections

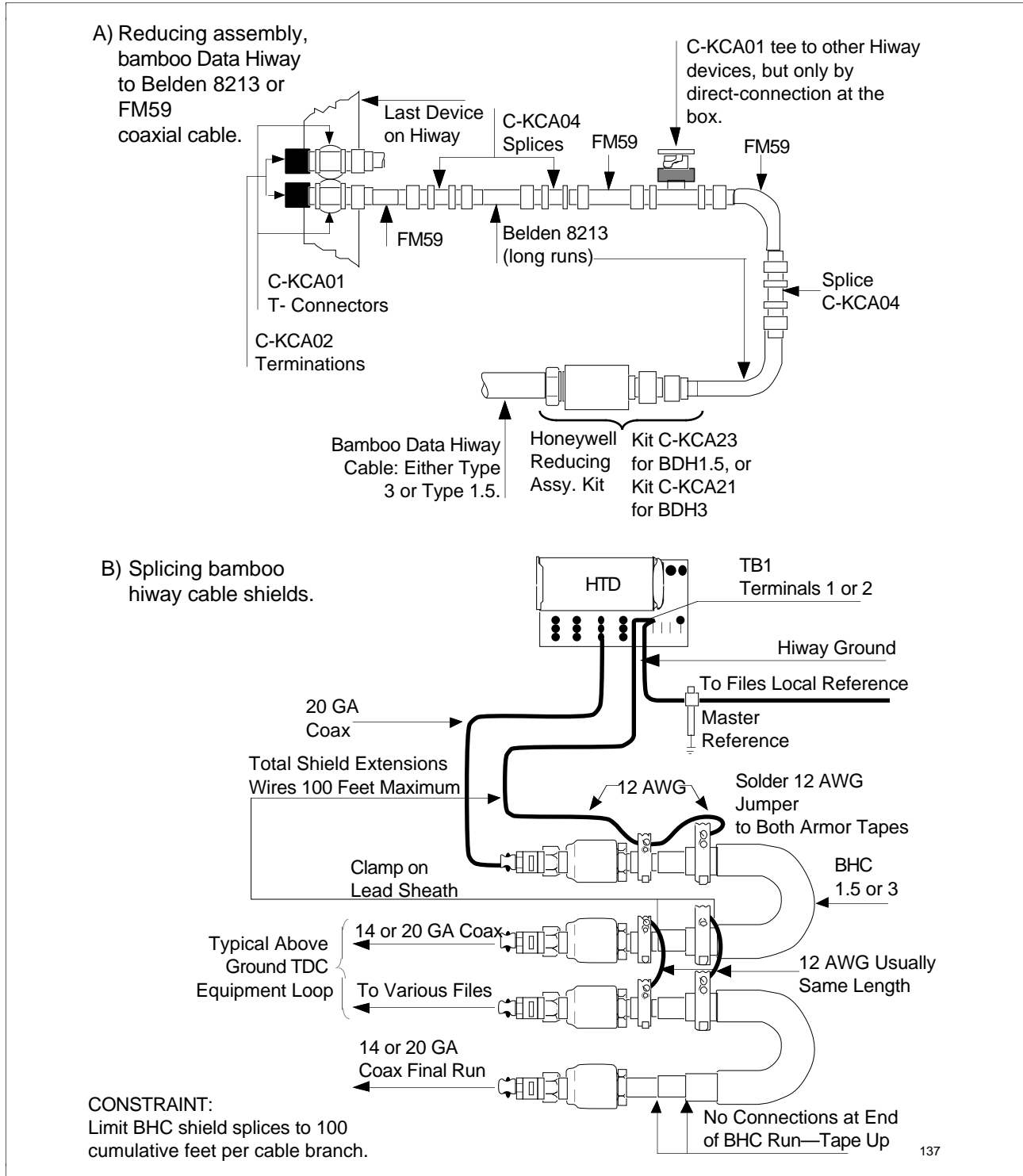

Continued on next page

4.30 Data Hiway Cable Installation, Continued

Coax cable

Table 4-10 Maximum Safe Pull Forces for Coax Cable

Data Hiway Cable Type	Minimum Radius Bend	Maximum Safe Pull Force
No. 14 AWG center-wire type (Polyethylene jacket)	15 cm (6 in)	712 N (160 lb)
No. 20 AWG center-wire type (Polyethylene jacket)	5 cm (2 in)	334 N (75 lb)
Bamboo 3 armored direct burial type (NO. 8 AWG)	50 cm (20 in)	5782 n (1300 lb)
Bamboo 1.5 armored direct burial type (NO. 1 AWG)	80 cm (32 in)	8674 N (1950 lb)
Indoor Fiber Optic Cable	15 cm (6 in)	1000 N (225 lb)
Outdoor Aerial Fiber Optic Cable	20 cm (8 in)	1300 N (293 lb)
Outdoor Direct-Burial Fiber Optic Cable	25 cm (10 in)	1300 N (292 lb)

Fiber optic cable

The Hiway Coupler Module (HCM), Local Control Network Extender (LCNE) and Local Control Network Fiberlink (LCNFL) are connected to fiber optic cable by using SMA-type (Amphenol Series 905 or equivalent) connectors, Figure 4-16.

To get smaller bend radiuses, outdoor cable must be spliced to indoor cable before connection is made to the circuit card.

Figure 4-16 HCM at Either End of a Fiber Optic Link

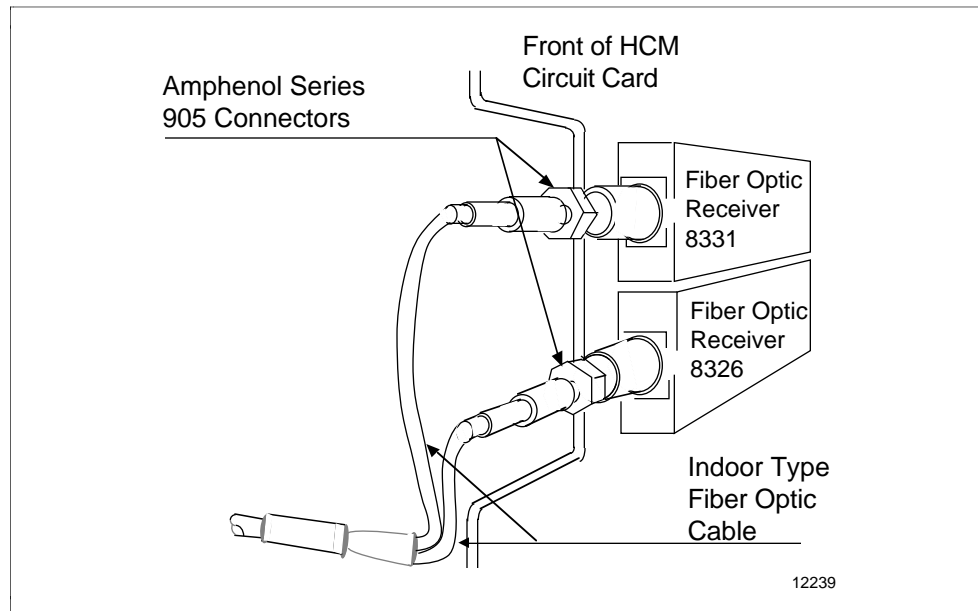

4.31 Data Hiway Electrical Loading

Specification

Each device connected to the Data Hiway communicates through a transceiver (similar in all devices) that puts one electrical load on the HTD.

- Each Data Hiway can include one, two, or three branches.
 - Each branch can have 29 electrical loads, including one load for the Hiway Traffic Director.
-

4.32 Data Hiway Address Capacity/Assignments

Specification

Each Data Hiway has 63 addresses that identify the devices to which communications are directed (see Table 4-10). With the following exceptions, each device connected to the Data Hiway is assigned one unique address:

- Operator stations, which all have the same address (address four).
 - Expanded PIUs (sometimes called large PIUs and MCs), which require two addresses.
 - The Hiway Traffic Director, which is not addressable (assigned address zero).
-

Continued on next page

4.32 Data Hiway Address Capacity/Assignments, Continued

Specification,
continued

Table 4-11 Data Hiway Address Assignments

	Configuration	Address
A	4500/0 with the HIM (used with PMC, PMX, SEER)	1
B	Hiway Gateway pairs must have one HG at an even address and the other (if present) at that address plus 1. Recommendation for the first pair are addresses (see Figure 5-15)	2, 3
C	All Basic and Enhanced Operator Stations (615, 520, 420 etc.) and all GPCIs and PCSIs.	4
D	Next HG pair (e.g., added or remote)	32, 33
E	Next HG pair (e.g., added or remote)	34, 35
F	PIUs, MCs, and DHPs take two addresses one of which must be in the range of 5 to 31, and the second is 32 greater than the first.	
G	Basic, Extended, and Multifunction controllers, and CBRCD, ECRCD, and MCRCD can take any address from 5 to 63.	
H	A single 620 HIM can have 2, 4, 6, or 8 box numbers, depending on the number of slots to be configured. <ul style="list-style-type: none"> • Each set of 2 box numbers (initial box number N, and N + 32) can contain 30 slots. • The initial box number N has a range of 5 to 31. • When using more than 2 box numbers for a 620 HIM, the initial (lower-order) box numbers must be consecutive starting with N, and the higher-order box numbers must be consecutive starting with N + 32. 	
I	The HIMX for the GG1 assumes the addresses of a series of PIUs and ECs.	
J	The hiway test box can take any address from 1 to 63.	
<p>NOTES</p> <ol style="list-style-type: none"> 1. No duplicate addresses are permitted on the data hiway with the exception of operator station and GPCI/PCSIs. 2. When installing a system with an HG, but without the HTD and optical hiway coupler, the maximum number of boxes is 28, see HG Wiring, Section 5. 3. The above rules are further constrained by use of the optical hiway coupler. See Branch Length and Polled Device Addressing Constraints, this section. 4. Reserve controllers do not have a hiway address until a "swap or fail" condition occurs, but do count as a coax load in the box count. 		

4.33 Preferred Devices

Description

Devices such as operator stations and computer interface units are designed to have a preferred access priority on the Data Hiway. Preferred devices in the Data Hiway request are granted access to the hiway through three shielded-twisted pairs of wire (Belden No. 9773 or equivalency). This route cannot exceed 1525 meters (5000 feet). See *Hiway Gateway Module Wiring*, Section 5.

4.34 Data Hiway Noise Shielding

Guidelines

Routing the Data Hiway through a bonded conduit that is grounded at both ends allows reducing the separation of the Data Hiway and the Master Reference/Hiway Ground wires and the noise sources to one third the minimum separation cited under the preceding headings. A bonded tray or a welded mesh can be substituted for conduit. If welded mesh is used, it must

- be fabricated of galvanized steel wire of 2.6 mm (No. 10 AWG) minimum diameter, with a mesh spacing of 75 to 100 mm (3 to 4 in)
- be welded where two mesh systems meet or cross.
- be at least 1.2 meters (4 ft) wide and 23 meters (75 ft) long at power crossings.
- be grounded at both ends to plant safety ground. Plant safety ground must be 1 ohm or less to true earth ground.

CONSTRAINT: The Bamboo Hiway cable armored spiraled tape shield does not qualify as grounded conduit.

NOTE: Refer to Section 5 for ground connections for the Data Hiway.

4.35 Branch-Length and Polled Device-Addressing Constraints

Guidelines

Data Hiway branch length is limited by transmission-time losses (signal-propagation delays) and power (dB) losses. At critical values, these losses can impair proper and expected operations in that portion of the TDC 3000 BASIC System.

Observance of the following guidelines ensures that losses remain within tolerable limits:

- No combination of cable can exceed 20,000 feet in length.
- If the composite branch length exceeds 6,000 feet, use Bamboo Data Hiway 1.5; if it exceeds 5,000, but not 6,000 feet, use Bamboo Data Hiway 3.
- Total of No. 14 coaxial Data Hiway cannot exceed 5,000 feet.
- Total of No. 20 coaxial Data Hiway cannot exceed 1,000 feet.
- A composite branch of No. 14 coaxial and a fiber optic link cannot exceed 16,100 feet.
- A composite branch of No. 20 AWG coaxial and a fiber optic link cannot exceed 8,600 feet.
- Total of Bamboo Data Hiway cable 3 cannot exceed 6,000 feet.
- Total of Bamboo Data Hiway cable 1.5 cannot exceed 20,000 feet.

Other combinations of AWG No. 14 and 20 coaxial cable, Bamboo Data Hiway No. 1.5 and 3, and fiber optic cable are permissible in constructing a Data Hiway branch so long as total time and power loss do not exceed the maximum allowable for proper signal propagation. Numerous cable combinations are possible depending on the application and distance requirements. Some examples follow:

- If a branch is less than 1,525 meters (5,000 ft) long, and cable between control houses can be run through conduit, No. 14 AWG coaxial cable can be used.
- If a branch is longer than 1,525 meters (5,000 ft), a combination of coaxial, Bamboo, and/or fiber optic cable can be selected.
- Bamboo cable can be used where for economic reasons the use of conduit is not feasible. Thus, a branch may consist of Bamboo cable underground and No. 14 AWG coaxial cable above ground, with No. 20 AWG coaxial cable used for cable runs between cabinets and consoles.
- A fiber optic link can be used in a branch where the Data Hiway must run through an area of potentially hazardous atmospheres or near power circuitry.

Continued on next page

4.35 Branch-Length and Polled Device-Addressing Constraints,

Continued

Guidelines,
continued

Any desired combination of cable types not covered by the above guidelines must be examined for losses to ensure that they do not exceed tolerable values. In addition, where polling is to be used in any branch containing fiber optic links, polling-address restrictions must be observed. Three areas of examination are outlined below in the order in which they should be followed. Ignore polling-address restrictions if polling is not used in the branch. If the branch fails to meet restrictions in one area, correct the conditions causing the failure before proceeding. It could require changing cable lengths or types.

1. Transmission Time Losses. The branch-cable composition must be examined by calculation to determine whether or not it will exceed the maximum tolerable transmission-time losses. The formula for finding total transmission-time losses (T) is as follows:

$$T = 2[(d_{1.5})(t_{1.5}) + (d_3)(t_3) + (d_{14})(t_{14}) + (d_{20})(t_{20}) + (d_{fc})(t_{fc}) + (\#fol)(t_{fol}) + (\#HTD)(t_{HTD})] + t_{resp}$$

where

$d_{1.5}$ = length of Bamboo Data Hiway cable 1.5

$t_{1.5}$ = propagation-delay time of Bamboo cable 1.5 = 0.001142 microsec/foot

d_3 = length of Bamboo Data Hiway cable 3

t_3 = propagation-delay time of Bamboo cable 3 = 0.001168 microsec/foot

d_{14} = length of No. 14 AWG coaxial cable

t_{14} = propagation-delay time of No. 14 AWG coaxial cable = 0.001337 microsec/foot

d_{20} = length of No. 14 AWG coaxial cable

t_{20} = propagation-delay time of No. 20 AWG coaxial cable = 0.001337 microsec/foot

d_{fc} = length of fiber optic cable

t_{fc} = propagation-delay time of fiber optic cable = 0.001319 microsec/foot

$\#fol$ = number of fiber optic links through which the data must pass

t_{fol} = fixed delay time through the fiber optic link = 5.2 microsec

Continued on next page

4.35 Branch-Length and Polled Device-Addressing Constraints,

Continued

Guidelines,
continued

#HTD = number of HTDs through which the transmitted data must
pass = 0 or 1*

t_{HTD} = fixed delay times through the HTD = 5.6 microsec

t_{resp} = response time of receiving device = 0 or 24 microsec**

* Equals 1 where the transmitted response signal must pass through the HTD, as from D2 to DA, Figure 4-17. Equals 0 where the signal stops at the HTD and does not pass through, as from D2 to HTD, Figure 4-17.

**Equals zero when a receiving device is responding to the poll word, because no additional time is required for transmitting the signal beyond the HTD. Equals 24 microseconds when the receiving device is responding to a command word because the signal must be relayed through the HTD.

It may be necessary to make several transmission-time-loss calculations to ensure that loss limits are not exceeded **in any section** of the branch where responses are transmitted over various distances and through or to various Data Hiway devices.

- Figure 4-17 shows a Data Hiway branch where time losses are significant in three sections of the Data Hiway: 1) from D2 to D1; 1) from D2 or D1 (whichever is farther from the HTD) to the HTD; 3) from D2 or D1 (whichever is farther from DA). The tolerable T value for each section, found by applying the transmission-time-loss formula, is as follows:

D2 to D1	$T \leq 132$ microseconds
D2 or D1 to the HTD	$T \leq 80$ microseconds
D2 or D1 to DA	$T \leq 132$ microseconds

No other T values are admissible. The calculation always involves either a polling response from a polled device (80 microseconds), or a command response from a box on the Data Hiway to a preferred-access device (132 microseconds).

ATTENTION

ATTENTION—In a Data Hiway that contains No. 14 coaxial or Bamboo cable, a minimum of 5 feet of No. 20 cable is needed for strain relief at the first box.

Continued on next page

4.35 Branch-Length and Polled Device-Addressing Constraints, Continued

Guidelines, continued

Figure 4-17 Data Hiway Branch with Two Fiber Optic Links

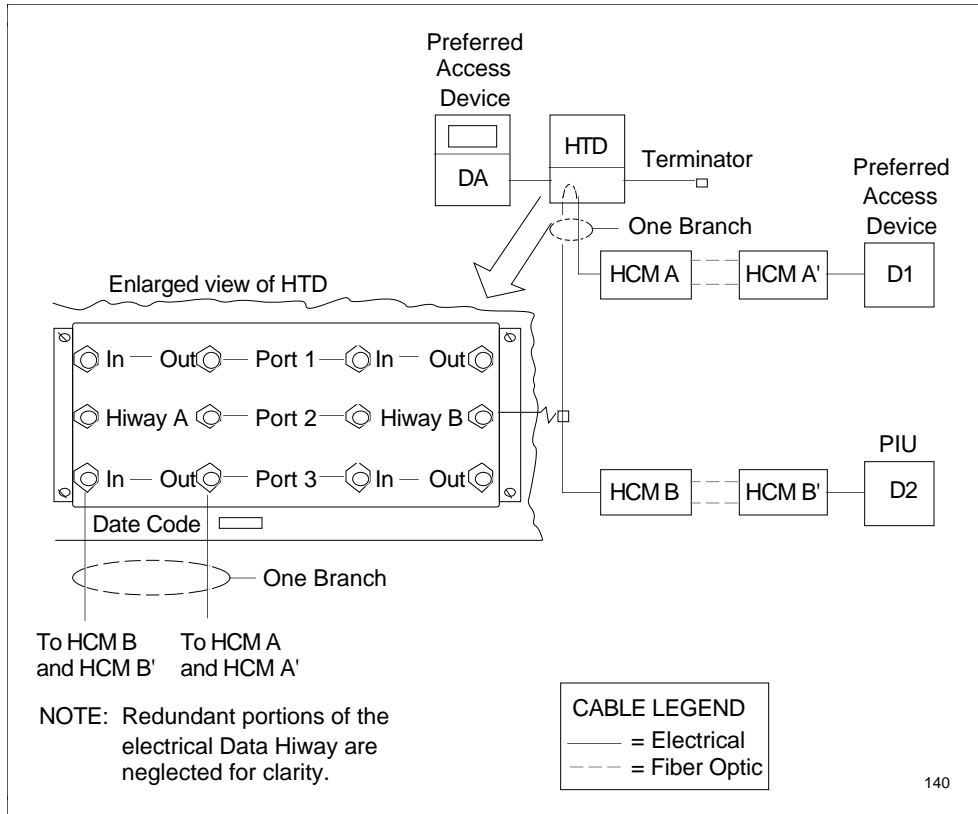

Continued on next page

4.35 Branch-Length and Polled Device-Addressing Constraints,

Continued

Guidelines,
continued

2. Power (dB) Losses in the Fiber Optic Link. The degree of transmission power lost in a fiber optic link depends on the length of cable used in the link and on the number of connectors and splices used in the link. The maximum total-power loss that is tolerable is 21 dB, which is the sum of the individual losses of the items in the link. Use the following data to sum up the power losses in the fiber optic link. If power losses exceed 21 dB, make adjustments as required to bring the losses to a tolerable level.

Items Contributing to Power Loss	Power Loss, dB ($\text{dB} = 10 \log_{10} \frac{P_1}{P_2}$)
Cable connectors (SMA)	1.5 dB for each connector*
Two in-line connections used as a splice	3.2 dB per coupler
Fiber optic cable	7 dB per Kilometer
Splices (Elastometric** or fusion)	0.25 dB per splice
System degradation	Fixed at 3 dB

* Two are used

**Tradename - GTE Electronic Components Division, Williamsport, PA

Continued on next page

4.35 Branch-Length and Polled Device-Addressing Constraints,

Continued

Guidelines,
continued

ATTENTION

3. Polling Address Restrictions. While HCMs can be used in multiple pairs anywhere in the system, Honeywell recommends that use be limited to one pair for each branch. In any branch containing one or more fiber optic links in parallel, where polling is used, the following polling address restrictions must be observed for satisfactory operation of the branch:

ATTENTION—The gaps required in addressing are needed to permit **recovery** from the affect of response signals transmitted through a parallel fiber optic link.

If a branch contains only one fiber optic link (HCMs A and A' Figure 4-18)—The first polled device on coaxial cable after the fiber optic link must be given a polling address number no lower than 8. In Figure 4-18 this is polled-device 1 (PD1), assuming the branch contains only the fiber optic link defined by HCMs A and A'. Other polled devices following PD1 on that coaxial-cable segment can be consecutively numbered; that is, PD2 can be given address 9, etc.

If a branch contains a second fiber optic link (HCMs Band B')—The first polled device on coaxial cable after the fiber optic link of greatest cable distance from the HTD must have the lowest address; that is, address 8. This polled device is represented by PD1 in Figure 4-18. Polled devices following PD1 on that coaxial cable segment can be consecutively numbered; that is, PD2 can be given address 9, etc. The first polled device after the next (or second) fiber optic link must be given a number 11 addresses higher than the last polled device after the first fiber optic link. Thus, if PD2 has address 9, PD3 must have address 20. Again, other polled devices following PD3 on that coaxial cable segment can be consecutively numbered.

If the branch contains a third fiber optic link (HCMs C and C'—It should be noted that 31 is the highest permissible address number for any polled device in the system. If in Figure 4-18 the HCMs C and C' represent the third fiber optic link, PD5 with address 31 represents the last permissible polled device and PD4 could not be used. (It makes no difference which **side** of an HTD port a second or third fiber optic link is situated on.)

Other polled devices on the branch—Polled devices on the branch Data Hiway that **are not** situated **downstream** of a fiber optic link, must be given the highest polling address in the branch. PD4 represents such a polled device in Figure 4-18 This, if the highest-numbered polled device after a fiber optic link has address 20 (PD3), PD4 must be given address 21.

Continued on next page

4.35 Branch-Length and Polled Device-Addressing Constraints, Continued

Guidelines, continued

Figure 4-18 TDC 3000^X System Showing One Branch

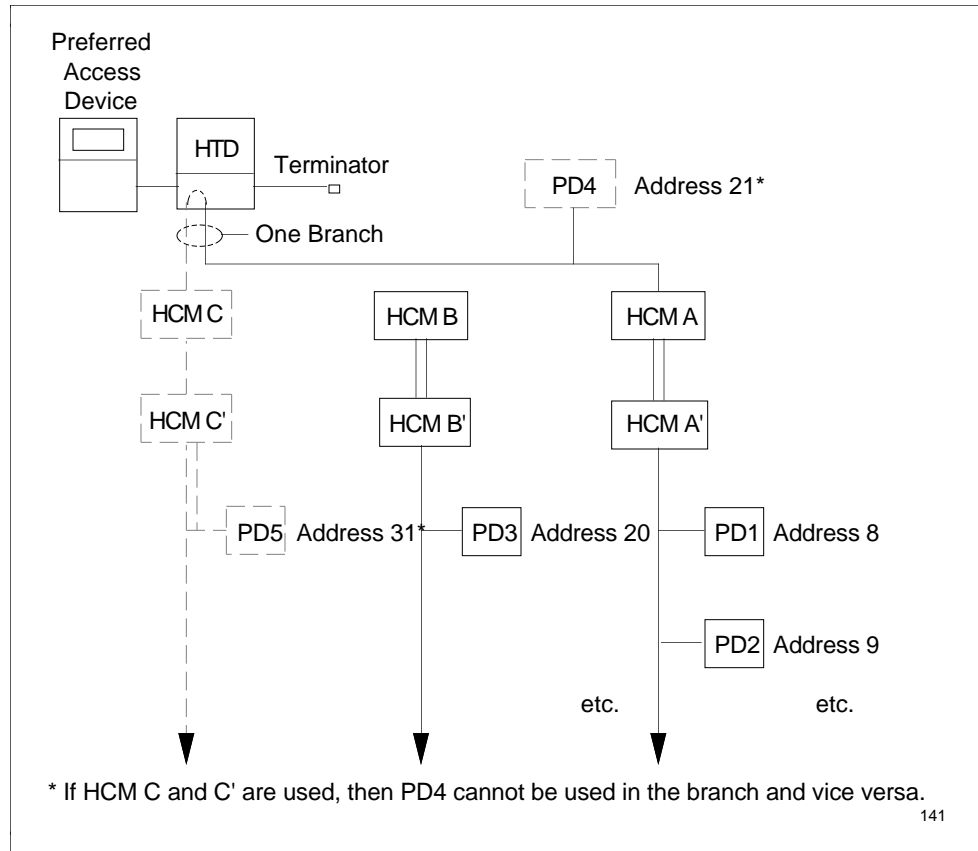

4.36 Preferred-Device Wiring

Description

Some devices, including the Hiway Gateway, can request and receive access to the Data Hiway on a preferred basis. Each preferred device is connected to the Hiway Traffic Director (HTD) by three shielded, twisted pairs (Belden #9773 or equivalent) .

1. Connect the shields of preferred device wiring (Master Request, Grant, and Switch) to the Power Supply Common (PSC) bus bar or to grant Common of the HTD or PAE.
 2. Do not connect shields to Terminal Block TB1-1 or TB1-2 of the HTD. The opposite ends of the shields are open (not connected to preferred devices). Refer to *Preferred Device Wiring Shield Grounds* in Section 5.
 3. Route the preferred-device wiring along with Hiway A or Hiway B cables. Follow the same procedures as for the Data Hiway.
-

4.37 Installing Underground Conduit

Guidelines

Install the conduit in accordance with API RP 550, *Manual on Installation of Refinery Instrument and Control Systems*, National Electric Code, or other equivalent industry standard. In addition to sloping the conduit, providing drain facilities, and using other standard recommended procedures, the following guidelines should be followed:

- Galvanized steel is most commonly used when conduit is installed underground.
 - Connect conduit sections with couplings that have a tapered pipe thread, as required by NEC.
 - For a leak-proof system (in or out), seal pipe threads with Teflon tape or pipe dope.
 - For conduit electrical continuity and complete grounding, connect jumpers across each coupling and pull box.
 - The smallest bend radius recommended is 635 mm (25 in). Make bends larger, if possible.
 - Specify the conduit length between pull boxes so that the maximum force recommended by the cable manufacturer is not exceeded.
-

4.38 Purging Conduit

Procedure

A water-logged conduit creates a capacitive coupling between the conduit and the coaxial cable. This permits electrical disturbances to be transmitted to the Data Hiway. To remove moisture from the conduit and maintain a dry system, purging is recommended.

- Purge the empty conduit with dry nitrogen or dry air to remove moisture.
- After pulling the cable, connect a continuous purge of dry air or nitrogen to maintain a moisture free system.

ATTENTION

ATTENTION—If conduit flooding is possible, the use of Bamboo Data Hiway cable (direct burial) is recommended.

4.39 Intrinsically Safe Wiring

Overview

Honeywell supplies zener barriers to interface equipment in nonhazardous locations with devices in hazardous locations. Intrinsically safe millivolt-to-current (mV/I) model C-AML01 and resistance-to-current (R/I) model C-ARB00 are also available for connecting to devices or elements in a hazardous location. NOTE: MV/I and R/I auxiliaries are intrinsically safe when mounted in a single-unit case and wired according to the Honeywell external-V/IR/Ing diagram. These two auxiliaries are also intrinsically safe when mounted in a multiunit file if the file contains only intrinsically safe mV/Is and R/Is. Intrinsically safe and nonintrinsically safe devices cannot be mixed in the same file.

Figure 4-18 illustrates how wiring in the cabinet is isolated. Note that wires for the nonhazardous locations are in a separate raceway or conduit.

Wiring Concepts

- All wiring to hazardous locations must be suitable for NEC Class 1 installations according to NFPA No. 70 Article 725 and local codes.
 - Refer to ISA RP12.6 *Installation of Intrinsically Safe Instrument Systems in Class Hazardous Location*.
 - Wires to a hazardous location (field wiring) must be separated from all other wiring by routing it through separate raceway or conduit.
 - Connections from the barrier or auxiliary to a field device must not be made through plugs, cables, terminal blocks, or other connecting devices that contain nonhazardous location wiring. Figure 4-21 shows the arrangement of barrier panels.
 - Field conductors can be a part of a multiconductor cable or bundle provided that all the conductors are intrinsically safe, originate at a barrier or approved auxiliary, and terminate at a Factory Mutual approved device or T/C, RTD, etc.
 - Field junction-boxes can be used, but the separation of the circuits must be maintained to avoid short circuiting two positive or two negative wires together. Such faulty conditions may or may not be obvious and can negate the desired safety.
 - Conductors from the barriers or auxiliary must leave the nonhazardous location by the shortest, most direct route to the hazardous location. Preferably, the terminal on the barrier or auxiliary should be the last connection at the interface.
 - Do not use Marshalling panels CTPM00, C-TPM01, or C-TPM02 in wiring between the zener barrier and the field devices.
 - Reference Document—*Zener Barriers for Intrinsically Safe, Process Control Loops*—S385-22.
 - For grounding information, refer to Section 5.
-

Continued on next page

4.39 Intrinsically Safe Wiring, Continued

Illustration

Figure 4-19 Intrinsically Safe Wiring for Auxiliary Files

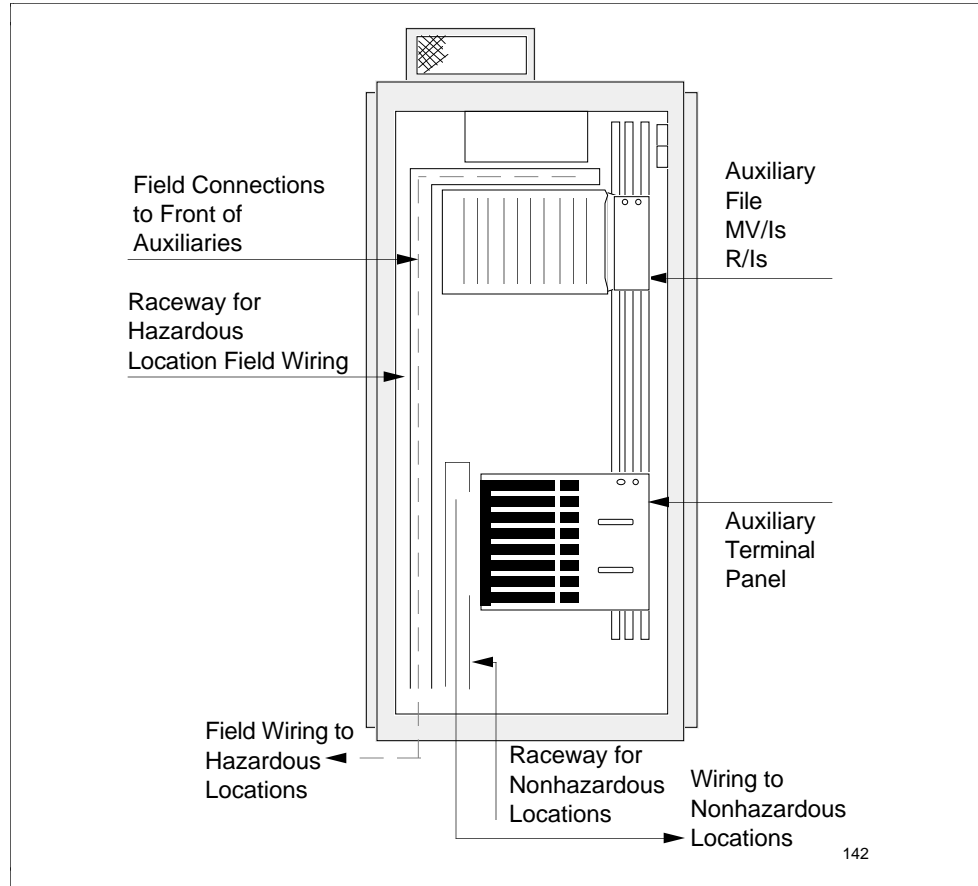

Continued on next page

4.39 Intrinsically Safe Wiring, Continued

Illustration

Figure 4-20 Barrier Panel Wiring

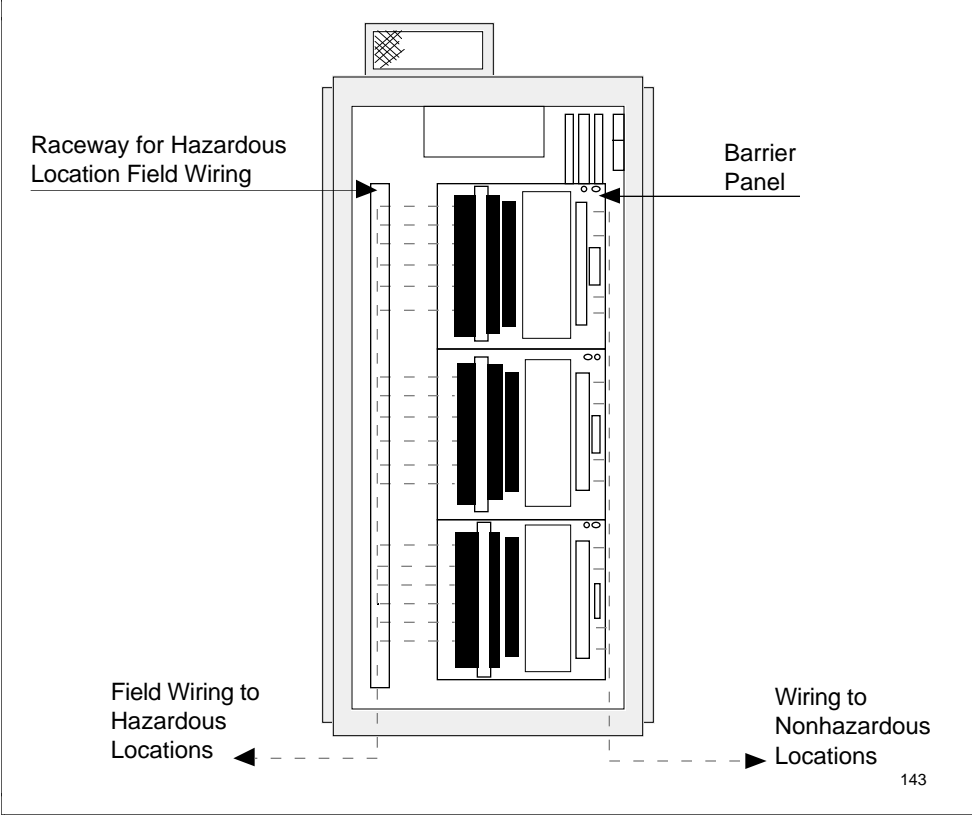

Continued on next page

4.39 Intrinsically Safe Wiring, Continued

Field input/output wiring

All field wiring into the hazardous location has distributed capacitance, inductance, and resistance. Because intrinsic-safety requirements are concerned with the amount of energy that can be released from circuits in a hazardous location, the stored energy in the distributed inductance and capacitance must be considered in determining the length of the lead wires.

Factory Mutual (FM) Specifications

Table 4-11 shows the maximum value of inductance and capacitance permitted by Factory Mutual for Honeywell, Inc. and Measurement Technology Limited, zener barriers. The Measurement Technology Limited barriers are used with the LEPIU for intrinsically safe installations. These values establish the maximum lead length that can be used with specific-type wire:

- The wiring-parameter limits are based on the most hazardous group for which the barrier is FM approved.
 - The measured parameters (capacitance and inductance) of the actual wiring system should be used when known.
 - Capacitance of a typical twisted pair of copper wires rarely exceeds 175 pF/m (60 pF/ft). At this capacitance, maximum length of the twisted pair can be calculated.
 - Honeywell, 38545-11 3, 2,100 meters (7,000 ft)
 - Honeywell, 38545-1 1 1, 4,800 meters (16,000 ft)
 - MTL, 115/116, 4,000 meters (13,000 ft)
 - The measured parameters (capacitance and inductance) of the actual wiring system should be used when known.
 - Capacitance of a typical twisted pair of copper wires rarely exceeds 175 pF/m (60 pFm). At this capacitance, maximum length of the twisted pair can be calculated.
 - Honeywell, 38545-113, 2,100 meters (7,000 ft)
 - Honeywell, 38545-1 1 1, 4,800 meters (16,000 ft)
 - MTL, 115/116, 4,000 meters (13,000 ft)
-

Continued on next page

4.39 Intrinsically Safe Wiring, Continued

Factory Mutual (FM) specifications, continued

- Inductance of a typical twisted pair of copper wires rarely exceeds 0.65 uH/m (0.20uH/ft). At this inductance, the maximum length of a twisted pair can be calculated.

Honeywell, 38545-113 3,000 meters (10,000 ft)

- Honeywell, 38545-11 1
6,600 meters (21,000 ft)
- MTL, 115, 2,200 meters
(7,500 ft)*
- MTL, 116, 2,400 meters
(8,500 ft)*

- The shortest lead wire length calculated is the limiting value.

* In the system using Low Energy PIU, this calculated length of wire includes the No. 14 AWG, wire between the barrier and the element lead-wire.

Table 4-12 FM's Maximum Allowable Values for Inductance and Capacitance

MFR	Barrier Model	Color	Group	Series Inductance	Shunt Capacitance
Honeywell	38545-113	Green	A,B,C,D,E,F,G	2.0 mH	0.4 μ F
Honeywell	38545-111	Red	C,D,E,F,G	10.0 mH	1.0 μ F
MTL	115	—	A,B,C,D	1.5 mH	0.8 μ F
MTL	116	—	A,B,C,D	1.5 mH	0.8 μ F

Section 5 – Grounding Considerations

5.1 Overview

Section contents

These are the topics covered in this section:

	Topic	See Page
5.1	Overview.....	101
5.2	Codes and References.....	103
5.3	Ground Sites.....	103
5.4	Isolation.....	104
5.5	Ground Loops.....	105
5.6	AC Safety Ground System (Mains) Ground.....	107
5.7	Basic Operator Station Safety Ground.....	109
5.8	Local Batch Operator Station—AC Safety Ground.....	109
5.9	Interposing Relay Terminal Panel Grounds.....	109
5.10	Cabinet Safety Ground.....	110
5.11	Data Entry Panels Case Ground.....	111
5.12	Lightning Grounds.....	112
5.13	Basic Operator Station DC Ground.....	114
5.14	LBOS Ground.....	115
5.15	C-Link Grounds.....	116
5.16	Single Cabinet DC Ground.....	117
5.17	Multiunit Cabinet DC Ground.....	118
5.18	Separated Controller Files and Terminal Panel.....	119
5.19	Hiway Traffic Director Ground.....	121
5.20	HTD Power and Ground.....	122
5.21	Preferred Device Wiring Shield Ground.....	123
5.22	Data Hiway Shields Ground.....	124
5.23	Signal Grounds for Devices on the Data Hiway.....	124
5.24	Hiway Gateway Wiring.....	125
5.25	Intrinsic Safety Grounds.....	129
5.26	High Level and Low Level PIU Ground.....	133
5.27	Low Energy CFA Ground.....	134
5.28	Fiber Optic Link Grounds.....	135
5.29	Marshalling Panel Grounds.....	136
5.30	Field Device Grounds.....	137
5.31	Grounding Summary.....	138

Continued on next page

5.1 Overview, Continued

Scope

Grounding considerations here apply to stand-alone BASIC and/or Batch TDC 3000 Systems. For site planning and grounding considerations of the LCN-based equipment and computers, see *System Site Planning* and *Local Control Network (LCN) Planning*. Electrical systems must be connected to ground (1) to protect personnel from electrical shock, (2) to protect equipment from damage, (3) to protect the site from lightning damage, and (4) to ensure the reliability and electrical integrity of the system. To satisfy all of these requirements, three separate grounding systems may be required. A ground system is a series of rods driven into the earth or a grid system to connect to true earth. Building frames, equipment housings, instrument signals, and lightning terminals are connected to these ground rods with appropriately sized wire.

These grounding systems are for distributed-control areas. If the individual areas are interconnected by only the Data Hiway, each area can have its own ac supply and grounding system:

- AC Safety Ground System (mains ground)—protects the plant power system, electrical equipment, and personnel from electrical shock. All metal equipment and enclosures are connected to this system through the safety-ground wire. If insulated, the wire is normally green. The ground wire and neutral wire are connected to the mains-ground rods or grid located where the power enters the building or job area.
- Lightning Ground System—dissipates lightning energy to protect personnel and the structure. Lightning energy is intercepted by air terminals and/or the building frame and conducted by cable to the ground rods or grid. Lightning system-ground rods are connected to mains-ground rods (safety ground) to prevent arcing between systems during a strike. Plants subject to direct lightning strikes should have a maximum lightning-ground resistance to true earth of 0.1 ohms. Substation grounding, buried counterpoises, and underground utilities can all be paralleled to get the desired figure.
- Master Reference (signal common) Ground—the reference point for all signals. All signal leads terminate at this point. Zener barrier ground bars (bus bars) and wire shields, including the Data Hiway shield ground, are all connected to this ground. To maintain system reliability and electrical integrity, the resistance to true earth ground should be less than 5 ohms for general-purpose area installations. The Master Reference Ground rods or grid is isolated from the safety- and lightning ground rods to avoid noise that they may carry.

For BASIC System with computers, computer-ground systems must be completely separate from the BASIC System grounds. Refer to the grounding instructions for the host computer and to H0-20-02, *General Purpose Computer Interface—Installation*. NOTE: Refer to paragraphs in intrinsically safe system-ground. See 5.25, *Intrinsic Safety Grounds*.

5.2 Codes and References

Ground rods

Ground rod systems must conform to local and national standards. Specific recommendations for design and installation of ground systems are contained in such technical publications as

- NFPA-70, Articles 250-80 and 85
- ISA 250-83-C paragraphs 1, 2, and 3
- IEEE-142
- Manual on Installation of Refinery Instruments and Control Systems, API RP 550, Section 7.
- Lightning Protection Institute Installation Code LP1-175

Carefully follow applicable guides and codes.

5.3 Ground Sites

Guidelines

In planning for the ground site, be sure to:

- allocate enough space
 - provide access roads and overhead clearance for construction equipment
 - avoid rocky areas
 - locate the ground site near a wet area, if possible
 - allow extra space for future expansion
 - locate within 152.4 m (500 ft) from ground stake to any equipment box or device
-

5.4 Isolation

Guidelines

Power-line noise saturates the entire area around the safety-ground (mains) rods.

- To prevent this noise from affecting the Master Reference (signal common and Data Hiway) Ground, separate it from the mains ground.
 - The preferred arrangement is to install the mains ground and instrument grounds on opposite sides of the control area. If this is not practical, separate all ground-rod systems by at least 3 m (10 ft).
-

5.5 Ground Loops

Overview

Signal-transmission circuits are sensitive to electrical interference that may be induced along the wire, such as

- ground-return paths of electrical equipment
- voltage variations in the natural soil
- battery action of the soil
- cathodic currents impressed on steel in-contact with the soil
- induced currents caused by artificially induced magnetic field from electrical machinery and distribution systems
- ground faults of electrical systems
- lightning and other atmospherically induced phenomena.

Examples

For example, Figure 5-1 shows a common instrument loop with a single Master Reference (common) Ground. If the transmitter signal is 12 mA, the voltage at points applied to the recorder will be 3.0 volts.

If a second ground is connected to the common line with a 0.1 volt ground loop (Figure 5-2), the recorder will read in error because for a 12 mA signal, a ground signal of 0.1 volt will be added to the 3.0 volts. The resulting incorrect signal, 3.1 volts, will be applied to the recorder.

Figure 5-1 Instrument Loop with Single Ground

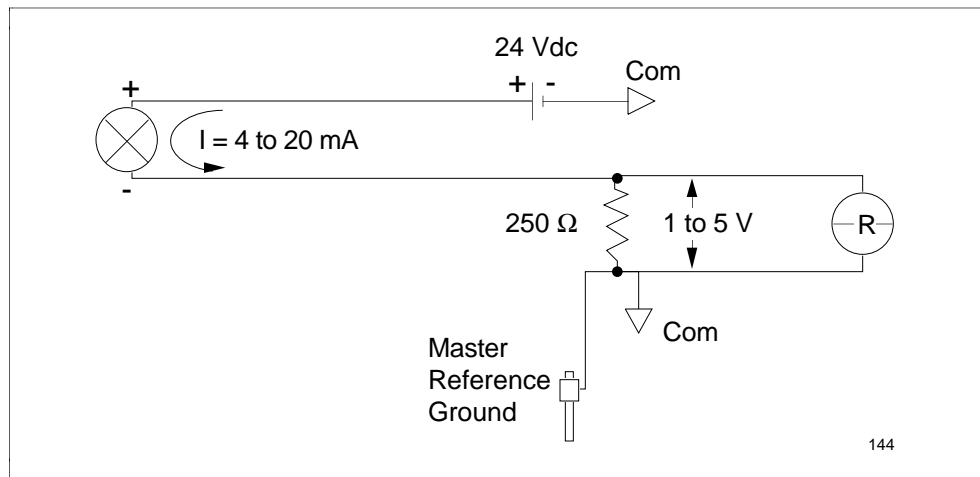

Continued on next page

5.5 Ground Loops, Continued

Examples,
continued

Figure 5-2 Instrument Loop with Two Grounds

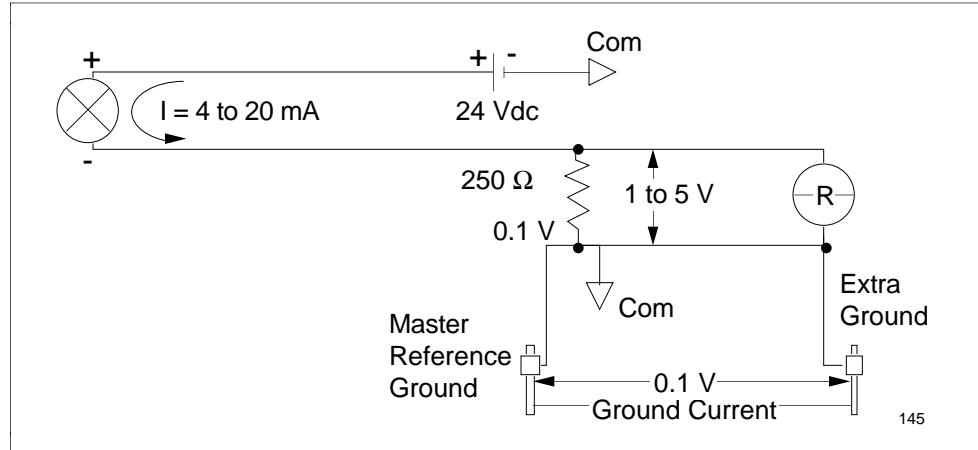

5.6 AC Safety Ground System (Mains) Ground

Requirement

The power source can be single phase or polyphase; in either case, the ac-neutral (white) wires must be connected to the ground (green with yellow tracer) wires and then to the main ground at the building or area entrance.

Figure 5-3 illustrates the mains grounding of the service panel at the building or area entrance. Note that the neutral (white) wire and ground (green) wire are connected to the safety-ground bus, which, in turn, is connected to the mains ground rods. Use a 5.3 mm (No. 4 AWG) or larger diameter wire.

Figure 5-4 illustrates the power source with a dedicated transformer. Note that the neutral (white) wire and the ground (green) wire are connected to the safety-ground bus in the mains service-panel, which, in turn, is connected to the mains ground at the building or area entrance. A 5.3 mm (No. 4 AWG) or larger diameter wire should connect the service panel to the ground rods.

Figure 5-3 Service Panel and Mains Ground Rods

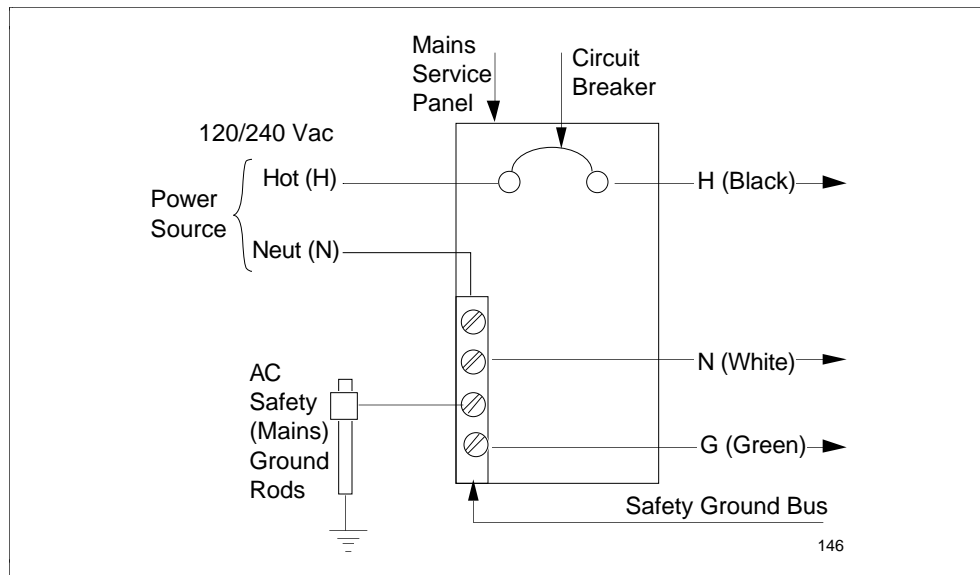

Continued on next page

5.6 AC Safety Ground System (Mains) Ground, Continued

Illustration

Figure 5-4 Power Source with a Dedicated Transformer

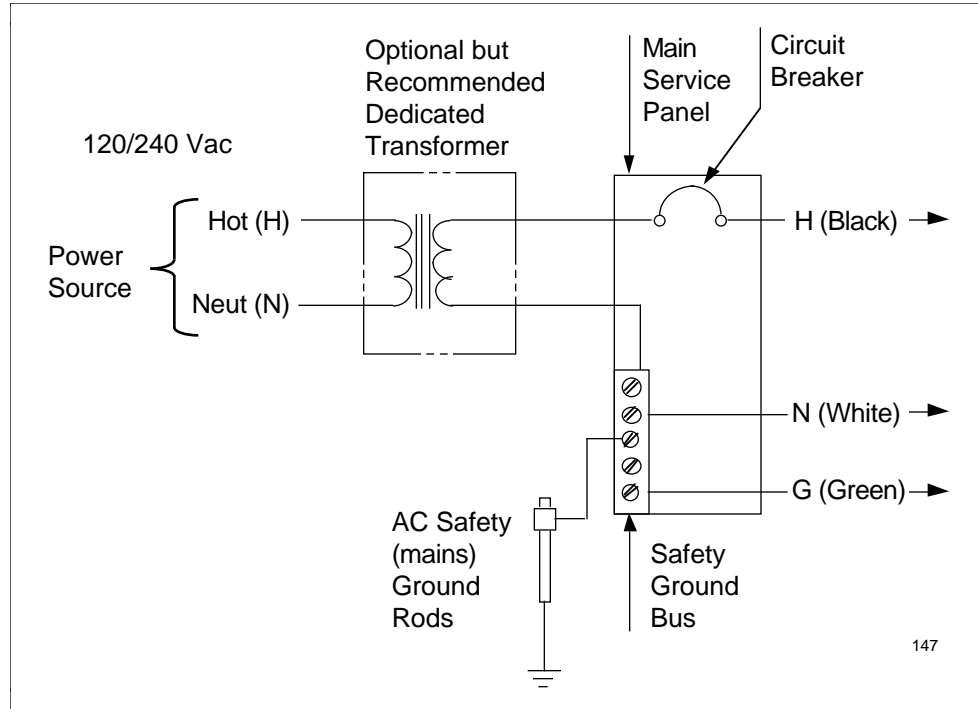

5.7 Basic Operator Station Safety Ground

Requirement Each operator-station power supply has an ac-input, dc-power assembly (Figure 4-2). The ground terminal TB6-1 on each power supply, the console safety ground, and the static surge condenser all go to safety ground. See Figures 4-2 and 4-3.

5.8 Local Batch Operator Station—AC Safety Ground

Requirement Ac-safety grounding at the LBOS is accomplished by plugging into a local receptacle. The green wire to the ac-safety (mains) service panel is connected from the ground bus of the local circuit-breaker panel serving the LBOS (see Figure 4-3). No connection is necessary at the frameground (FG) terminal on the back of the LBOS. The printer normally plugs into the same receptacle and is grounded in the same way.

5.9 Interposing Relay Terminal Panel Grounds

Requirement Ac signals in the 0 to 5 ampere and 0–250 Vac range, are wired to and from the interposing relay panels. These signals must not be grounded to, or in any way associated with, the Master Reference Ground (MRG) system. Relay cables must be grounded **only** to safety-ground block(s) in system cabinets.

5.10 Cabinet Safety Ground

Requirement

To further protect personnel, redundant safety grounds can be used to reference all equipment and enclosures to ground (earth). Safety grounds are all tied to ac mains-ground rods through the ground (green) wires. For location of cabinet's safety-ground terminal lug, see Figures 4-4 and 4-5.

5.11 Data Entry Panels Case Ground

Requirement

Connect 0.8 mm (No. 20 AWG) or larger diameter wire from ground connection on power end-cap assembly and on Data Entry Panel display to safety ground (Figure 5-5) .

Figure 5-5 Data Entry Panel Case Ground

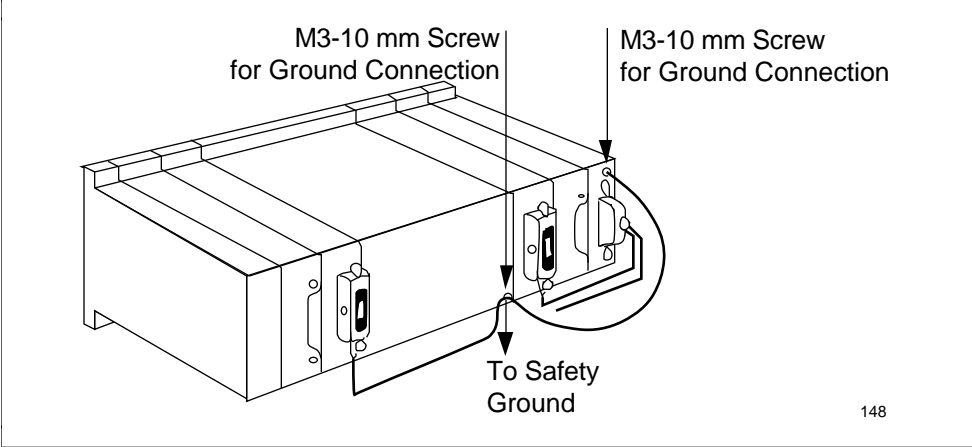

5.12 Lightning Grounds

Requirement

Lightning grounds must conform to applicable codes such as NFPA No. 78 (ANSI), IEEE Std. 142-1972, Code LP1-175, and other local codes. Typically, a lightning-ground system consists of 10-ft ground rods bonded (connected) to vertical structural members every 100 feet along the building perimeter. Normally, the mains ground is bonded to the lightning ground.

Master Reference Ground must be isolated from all other grounds. Where ground wires are close together (usually in enclosures), there is always the possibility of arcing (flash) between ground wires when lightning strikes.

To prevent this hazardous arcing, some codes require all ground wires to be connected through spark-gap devices at the building perimeter. Figure 5-6 shows the Master Reference (common) Ground and the low-level shield grounds connected to a building vertical-frame structure that is also connected to the lightning ground rod. Spark-gap devices connect all ground wires to avoid an excess-voltage difference that may be created by a lightning strike.

Honeywell recommends 90-volt spark gaps for TDC-3000^X system grounds.

Continued on next page

5.12 Lightning Grounds, Continued

Illustration

Figure 5-6 Lightning Ground (General Purpose Area)

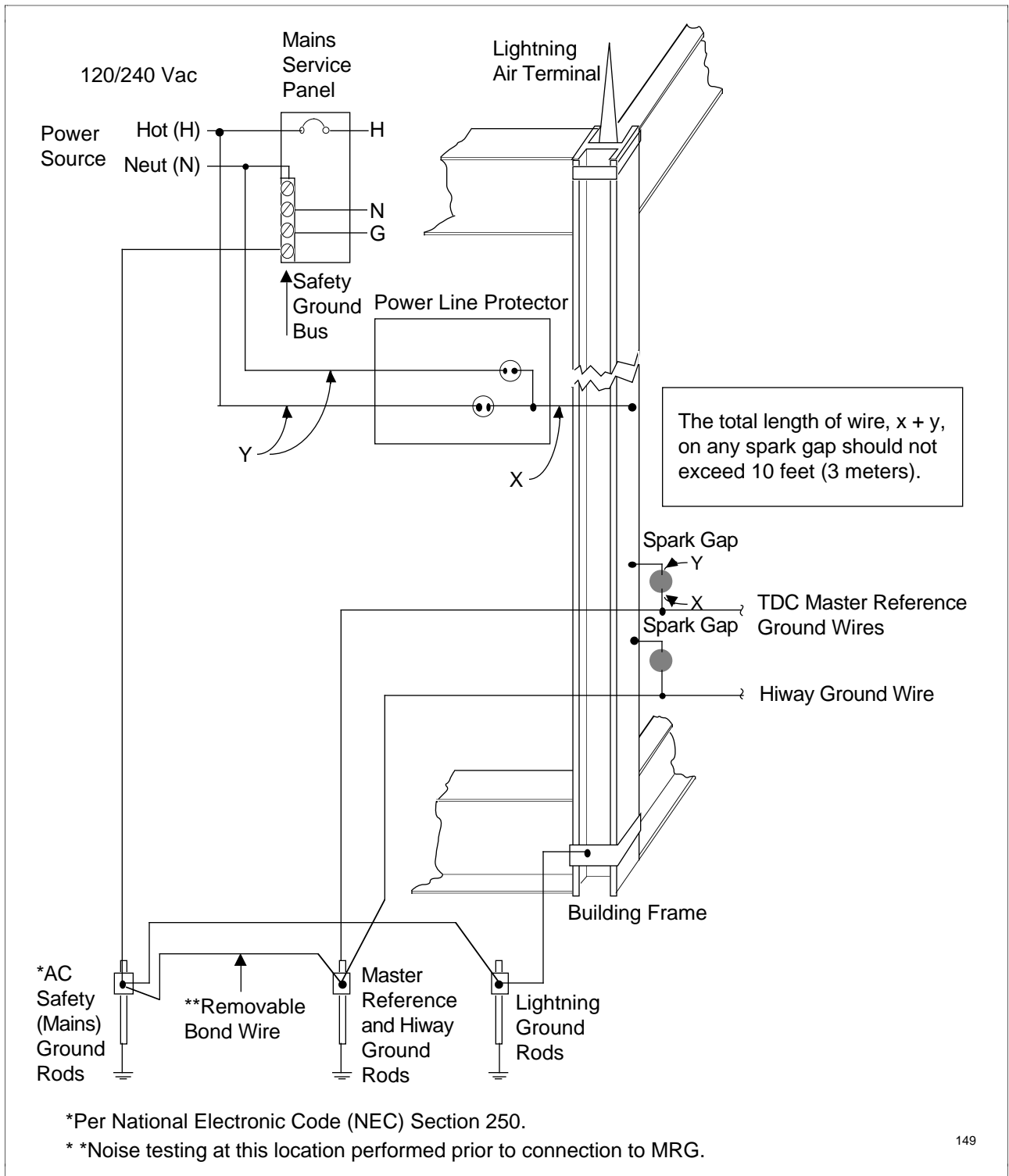

5.13 Basic Operator Station DC Ground

Requirement

Each operator station internally converts ac power to 24 Vdc, 12 Vdc, and 5 Vdc for operation of the keyboard and the operator-station file. These dc potentials and common (COM) are connected to terminal block TB2, accessible from the front of the operator station, see Figure 5-23. Connect terminal 5 of TB2 to Master Reference with a 14 AWG pigtail to the 4 AWG electrode wire. If two or more operator stations are used, they can all be connected by a single ground wire; however, a separate ground wire for each station eliminates the loss of ground if one station is removed.

5.14 LBOS Ground

Requirement

The LBOS requires two ground connections:

- Safety or Frame Ground (FG)
- Logic Common (LC)

Frameground and Logic Common ground connections are detailed in Figure 5-7.

Figure 5-7 LBOS Safety Ground and Logic Common Grounds

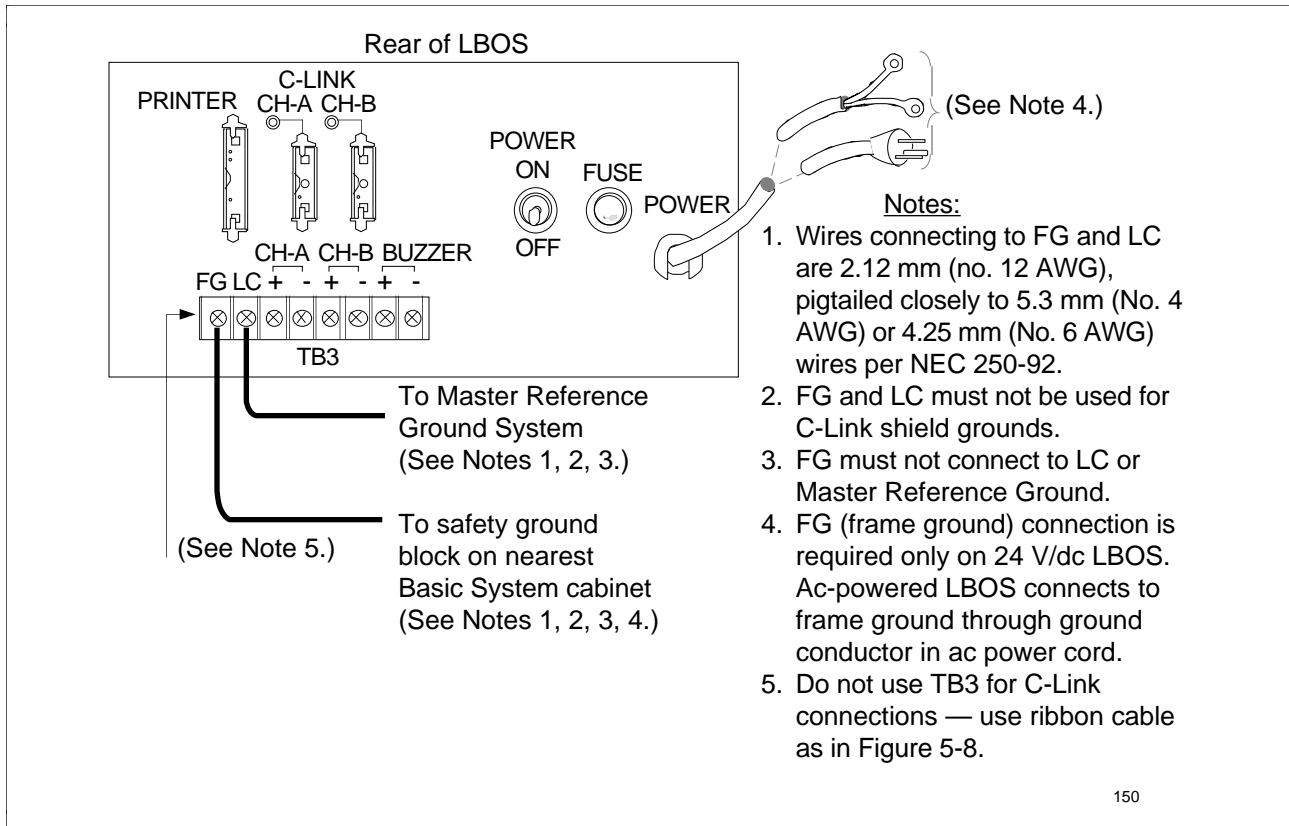

5.15 C-Link Grounds

Requirement

The C-Link cable is daisy-chain connected to the LBOS and to Multifunction Controllers through Adapter Boxes KRA00. (See Figure 4-10 and associated text, *C-Link Communications Cables* and Figure 5-8.)

The C-Link shields are internally connected in each KRA00 to the right-most (COM) screw on the KRA00 terminal strip. For each C-Link, the right-most (COM) terminal on only one KRA00 is connected to Master Reference Ground.

1. The C-Link shield must not be grounded at more than one KRA00, or more noise will be introduced into the C-Link system.
2. Provide a separate (dedicated) wire for C-Link shields to Master Reference Ground. Do not pigtail the Logic Common (LC) wire from the LBOS (Figure 5-7) to the C-Link shield-ground wire.

The C-Link shield ground connection to the KRA00 associated with the LBOS is shown in Figure 5-8.

Figure 5-8 C-Link Shield Grounding

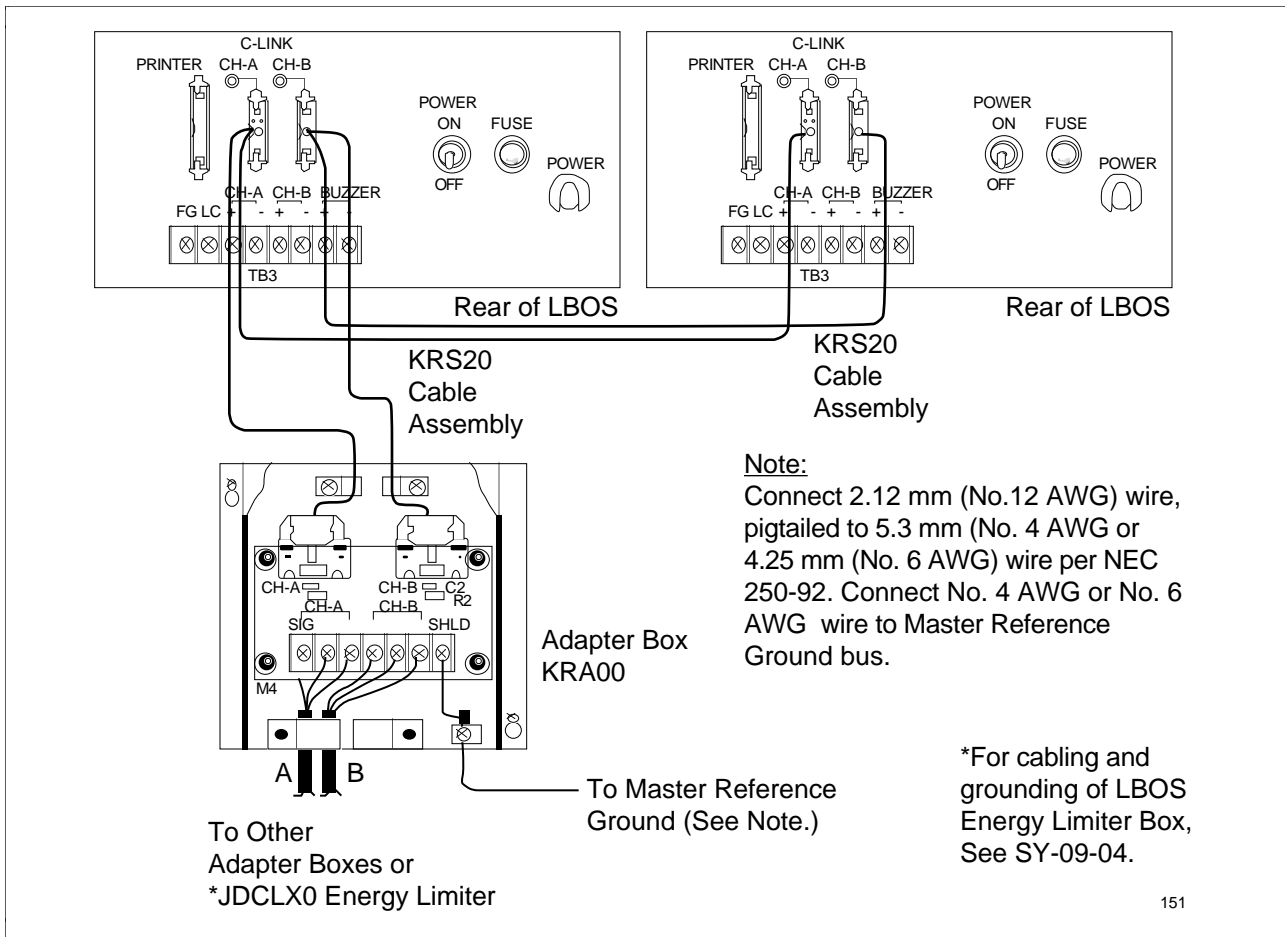

5.16 Single Cabinet DC Ground

Requirement

Single cabinets require a separate 5.3 mm (No. 4 AWG) wire that connects the SC bus and the PSC bus to the Master Reference Ground rods. Figure 5-9 illustrates the ground connection for a cabinet with one back pan. The SC to PSC jumper is factory-installed.

When two back pans are supplied in a single cabinet, the two sets of bus bars are jumpered at the factory.

Figure 5-9 Single Cabinet DC Ground

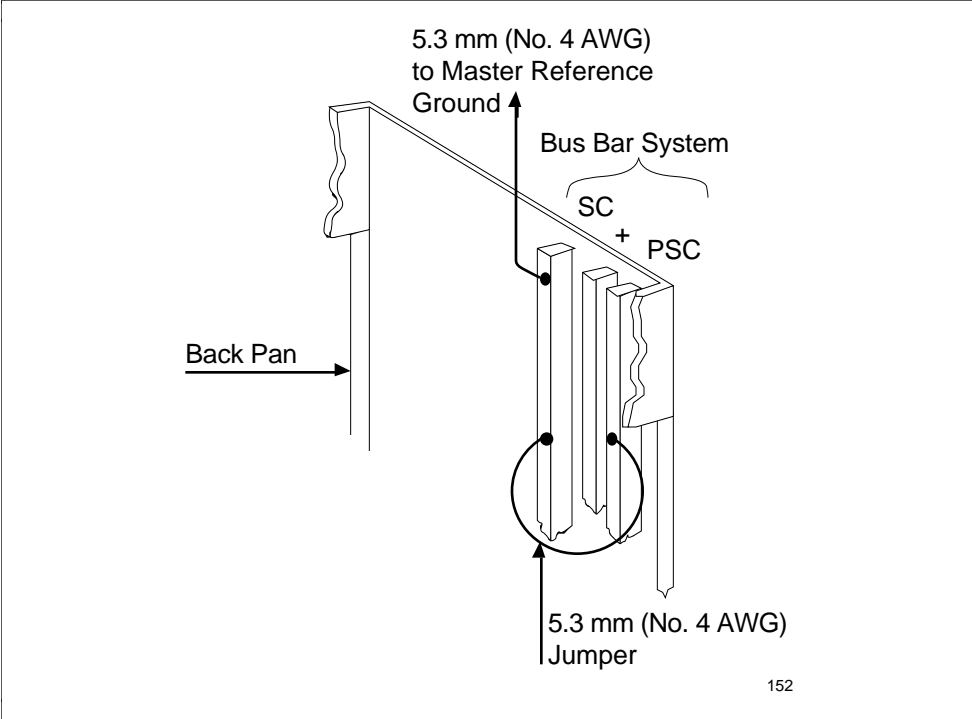

5.17 Multiunit Cabinet DC Ground

Requirement

Cabinets are supplied with up to five attached units. When two or more units are connected, a Local Reference bar is supplied. PSC and SC buses are connected as in Figure 5-10.

If the units are all located in the same area, connect all cabinet Local Reference bars to a common-ground bus that is insulated from the building frame and run a single 5.30 mm (No. 4 AWG or larger) ground wire back to Master Reference Ground.

Figure 5-10 Local Reference Bar

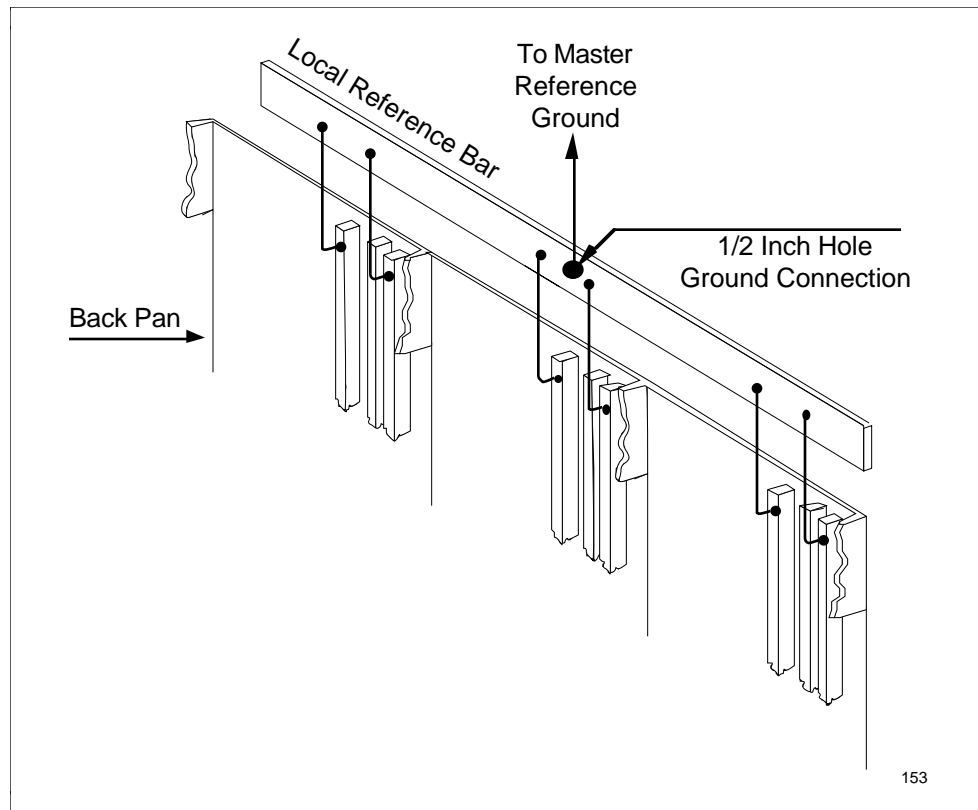

5.18 Separated Controller Files and Terminal Panel

Guidelines

When controller files and terminal panels are mounted in different cabinets (different back pans), they can be separated by up to 60 meters (200 ft) of 50-conductor cable.

Figure 5-11 shows the preferred method of wiring with separate dedicated branch power-circuits for files and terminal panels. A Local Reference bar is mounted on cabinets with terminal panels. This Local Reference bar is field-connected to the Master Reference Ground with 5.3 mm (No. 4 AWG) or larger diameter wire.

To complete the grounding, all Local Reference bars are individually wired to a control point and grounded to Master Reference. The size of these wires must be selected to minimize the effect of current flow. Use Table 5-1 to calculate total amp-meters. Select wire size from Table 5-2.

Table 5-1 Current Flow between File Systems and Terminals

No. of valve outputs	x 0.02 =	_____ amps
No. of alarm contacts	x 0.04 =	_____ amps
No. of analog displays	x 0.01 =	_____ amps
No. of recorders	x 0.50 =	_____ amps
No. of transmitters	x 0.02 =	_____ amps
No. of auxiliary relay coils	x 0.06 =	_____ amps
Only if terminal panels are powered by supply in cabinet with controller files	TOTAL =	_____ amps
Total amps x No. of meters between controller files and terminal panels	=	_____ ampere-meters

Table 5-2 Wire Size for Connection between Files and Terminal Panel's Local Reference Bar (200 mV IR Drop)

From Table 5-1 Ampere-Meters (Ampere-Feet)	Wire Size in mm
Up to 228.6 (750) (e.g., 15 amp x 15.24 M)	5.30 (#4 AWG)
UP to 304.8 (1000)	6.00 (#3 AWG)
Up to 381.0 (1250)	6.70 (#2 AWG)
Up to 487.7 (1600)	7.50 (#1 AWG)
Up to 609.6 (2000)	8.50 (#0 AWG)
Up to 762.0 (2500)	9.50 (#00 AWG)
Up to 914.4 (3000) (e.g., 15 amp x 60.96 M)	10.60 (#000 AWG)

Continued on next page

5.18 Separated Controller Files and Terminal Panel, Continued

Illustration

Figure 5-11 Separate Dedicated Power Circuits

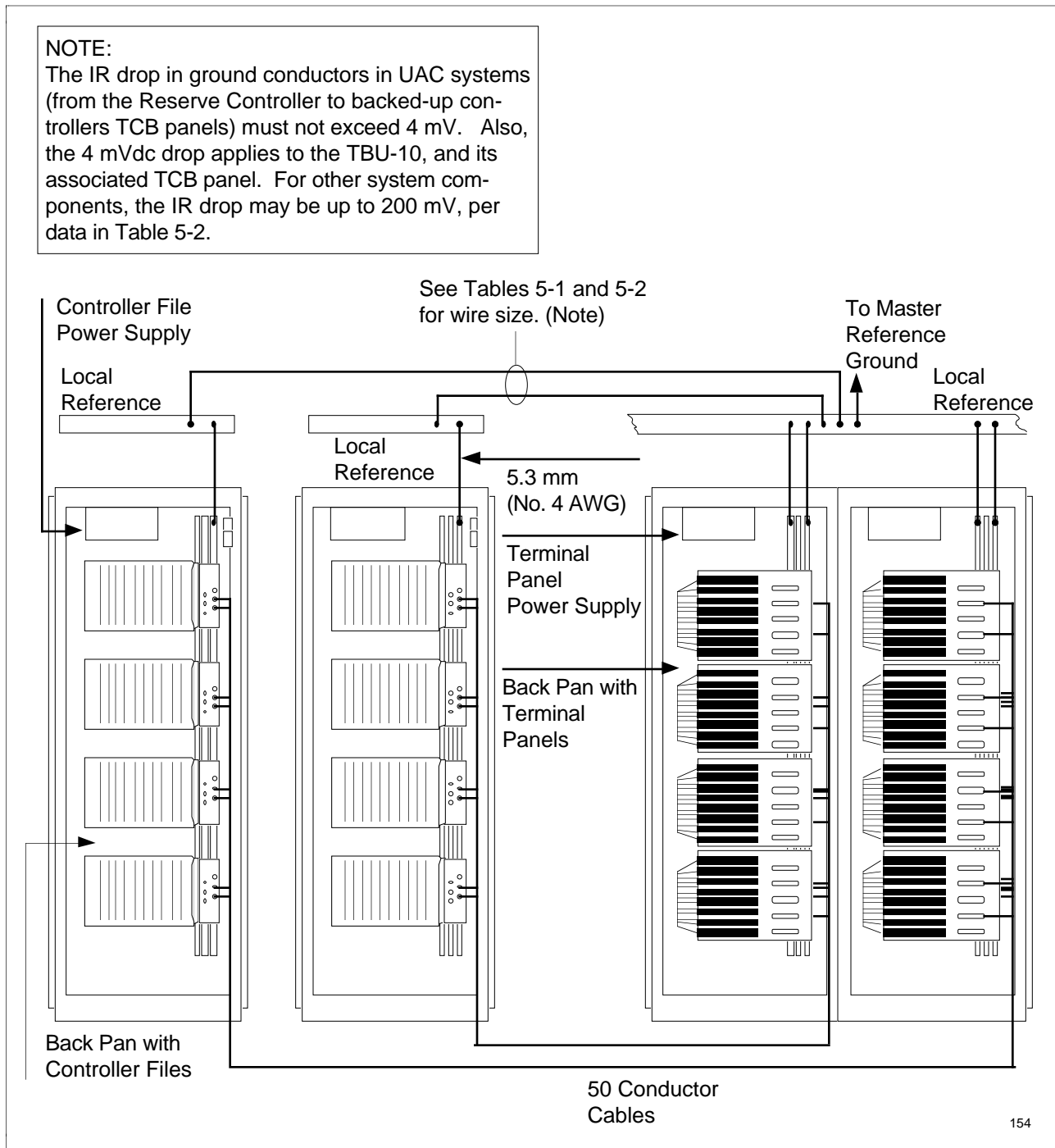

5.19 Hiway Traffic Director Ground

Description

The Data Hiway consists of redundant cables (Hiway A and Hiway B) and an internal Hiway Traffic Director (HTD). The Data Hiway's ground path from Master Reference Ground is through TB1-1 or TB1-2, then through a printed-circuit path to the hiway BNC-connector shells.

The HTD power-supply ground and the Data Hiway shield are grounded to Master Reference. HTD preferred access-cable shields must be connected to the PSC bus or Grant Common, as shown in Figure 5-12.

Figure 5-12 Preferred Device Wire Shield Ground

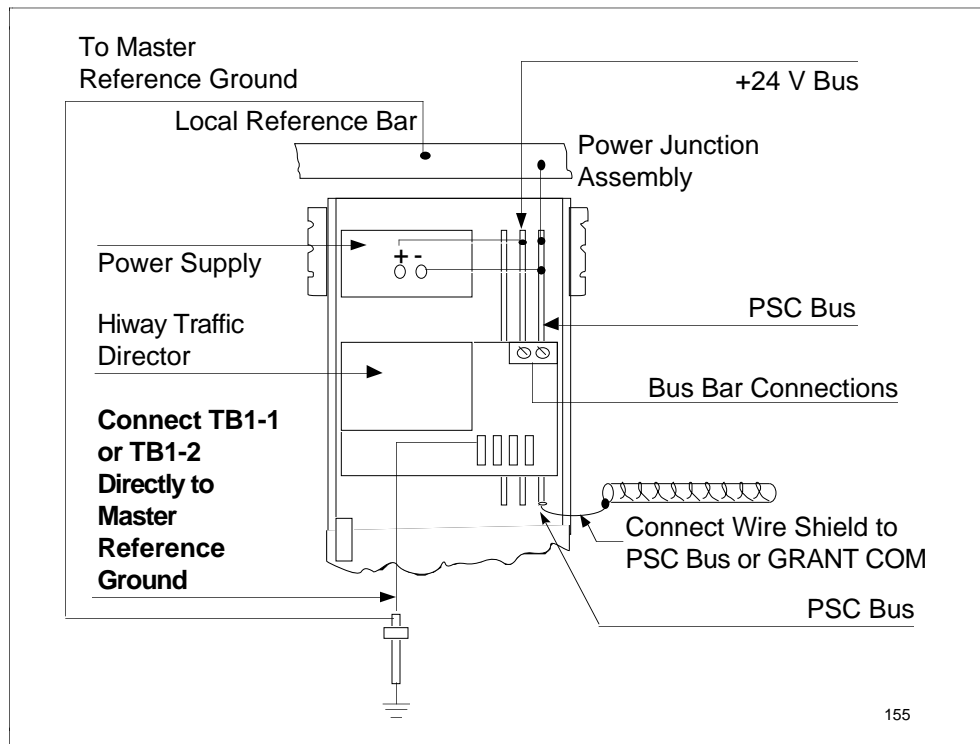

5.20 HTD Power and Ground

Description

The HTD is mounted on the back pan and is powered from the bus-bar system (Figure 5-12). The bus system is powered by a 24 Vdc supply connected to the +24 volt bus and the PSC bus. The HTD is connected to the bus-bar system by terminal screws in the upper right-hand corner of the backplane. This provides power to operate the HTD and Data Hiway.

When the HTD is installed in a cabinet, a Local Reference bar for Master Reference Ground is mounted on top. The PSC bus bar is connected to the Local Reference bar, which is, in turn, connected to the Master Reference Ground.

When the HTD is mounted in an operating-center console where the Local Reference bar is not used, connect a 5.3 mm (No. 4 AWG) wire from common of the SJA00 power junction assembly to Master Reference Ground.

5.21 Preferred Device Wiring Shield Ground

Description

Each preferred device is connected to the HTD by three cables, each consisting of a shielded twisted pair (Belden #9773 or equivalent). These cable pairs are connected to terminals 3-4, 5-6, and 7-8 of the preferred device terminal-blocks TB1, TB2, TB3, and TB4 (Figure 5-13).

CAUTION

CAUTION—Connect all shields to the PSC ground bus (Figure 5-12) or to GRANT COM terminal at the HTD.

ATTENTION

ATTENTION—Do not connect these shields at any of the preferred devices. Do not connect the preferred device-wire shields to terminals 1 or 2 of TB1. These are reserved for the Data Hiway shield.

Figure 5-13 Preferred Device Terminal Wiring

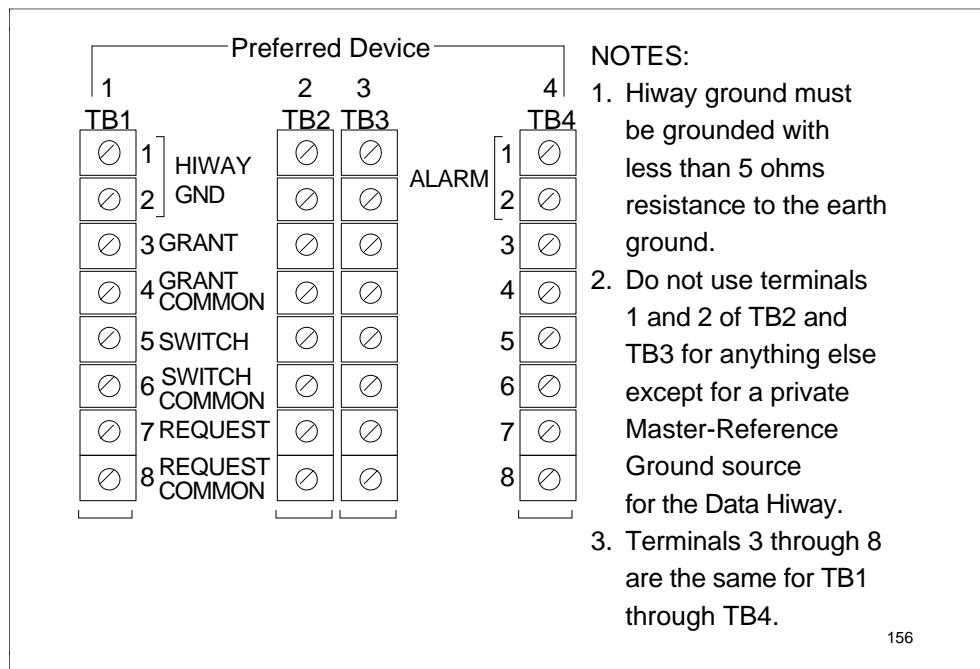

5.22 Data Hiway Shields Ground

Guidelines

The following guidelines are recommended for grounding of the hiway cable shields:

- The Data-Hiway shield is internally connected to terminals 1 and 2 of TB1 (Figure 5-13). Connect a 5.3 mm (No. 4 AWG or larger) wire from terminals TB1-1 or 2 to Master Reference Ground. Use a 14 AWG pigtail to keep strain off of TB1. The impedance to true earth ground must be less than 5 ohms.
 - Do not connect the Data-Hiway shield to ground at any other location. A ground loop on the hiway may cause communications problems.
 - Be sure that heat-shrink insulators are on all cable connections to prevent accidental grounding.
-

5.23 Signal Grounds for Devices on the Data Hiway

Requirement

Connect the signal commons (power supply commons) for all boxes on the Data Hiway to Master Reference Ground through a suitably heavy wire. All files in one area (such as a control room) can share the wire to Master Reference Ground.

5.24 Hiway Gateway Wiring

Rules

The Hiway Gateway (HG) communicates with other TDC 3000^X modules and gateways on the Local Control Network (LCN) and with process-connected boxes on the Data Hiway, as shown in Figure 1-2. It can be used with a backup HG, with or without a Hiway Traffic Director (HTD). Each HG module includes a Data Hiway Interface (DHI) card, as shown in Figure 5-14. The following installation rules apply:

- Whenever a system has Hiway Gateways (HG) as well as an HTD, the hiway is to be grounded only through the HTD. On the HGs, all wiring on terminals 11 and 13 (Figure 5-14) is to be removed and individually taped up.
- If the system has two HGs on the same hiway branch, grounding is required on the primary HG, not on both. As mentioned earlier, wiring to terminals 11 and 13 of the secondary HG is to be removed and insulated to prevent communications problems should the shields short together.
- The HGs must be within 100 cable feet of each other so that polling calibration will be correct for both the primary and secondary HG without changing any setting.
- When the HG is acting as the HTD (systems without the HTD), TB1 terminals 9,10, and 3, 4 are outputs for the hiway grant; however, when the HG is not the HTD, terminals 9, 10 are used to request the hiway from the HTD, as shown in Figure 5-15.

An HG failover wiring diagram, supporting one other preferred access device, usually an operator station, is illustrated in Figure 5-16.

CAUTION

CAUTION—Only one of the two Hiway Gateway paddle boards of a HG pair is connected to the master reference ground (MRG). If, for some reason, the HG paddle board connected to the MRG is replaced, a temporary MRG connection must be made to the other HG paddle board prior to replacement, and removed after replacement.

An HG cutout switch (for example) can be used in early TDC 3000^X LCN installations to provide one more degree of security for the user should a problem occur with the HGs not responding to requests and thereby locking the Operator Station out of hiway grants. The switch is not a standard product. Should such a problem occur, the user can operate the switch which causes the Operator Station to issue its own grants upon request and gain hiway access.

After the HGs have been repaired and are to be returned to service, the operator should return the switch to the normal position. Failure to restore the switch will cause message collisions on the hiway which are to be avoided. The switch is not a standard product.

Continued on next page

5.24 Hiway Gateway Wiring, Continued

Illustration

Figure 5-14 Hiway Gateway Interface Card Showing TB1

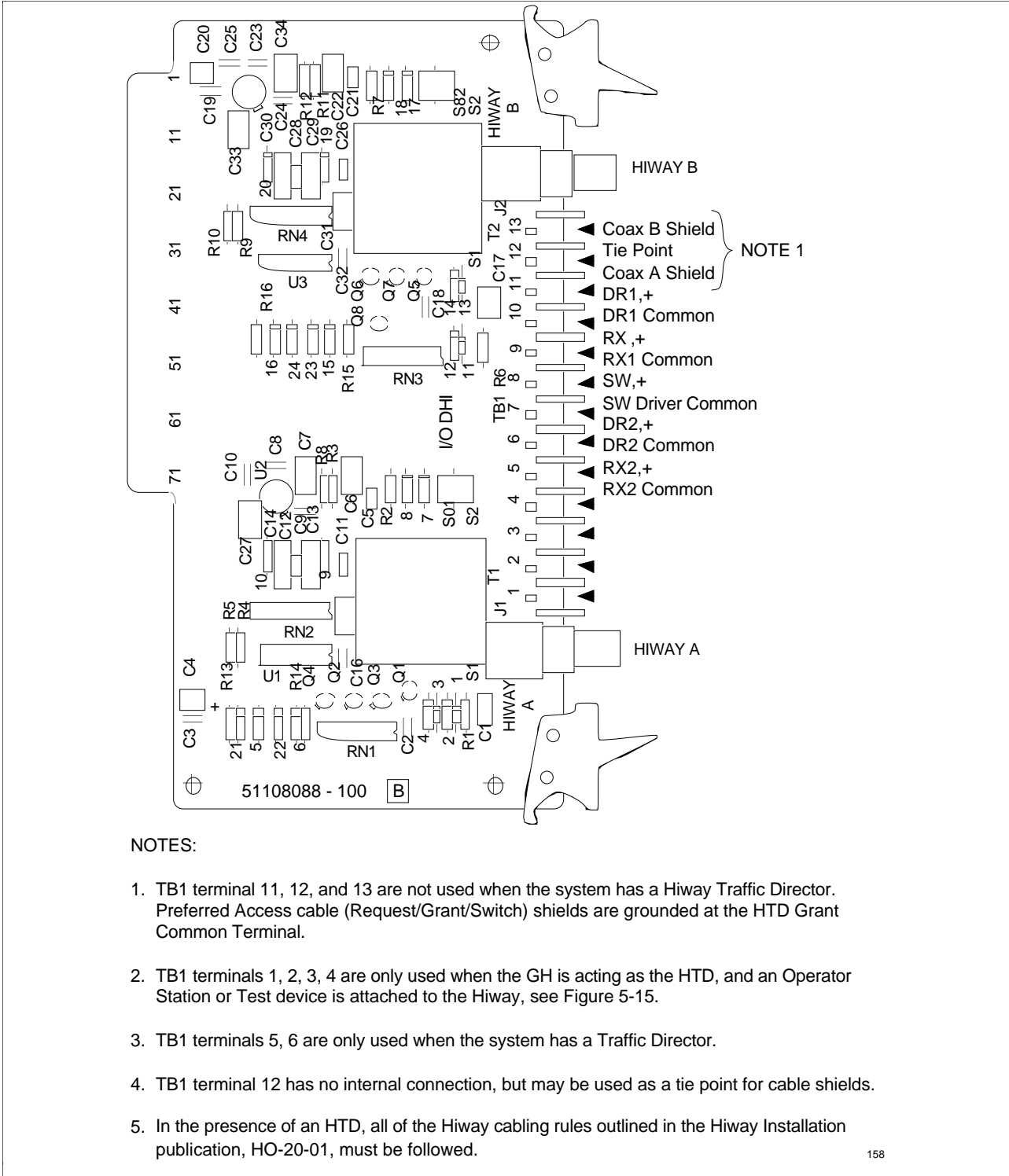

158

Continued on next page

5.24 Hiway Gateway Wiring, Continued

Illustration

Figure 5-15 Overview of Preferred Access Cabling

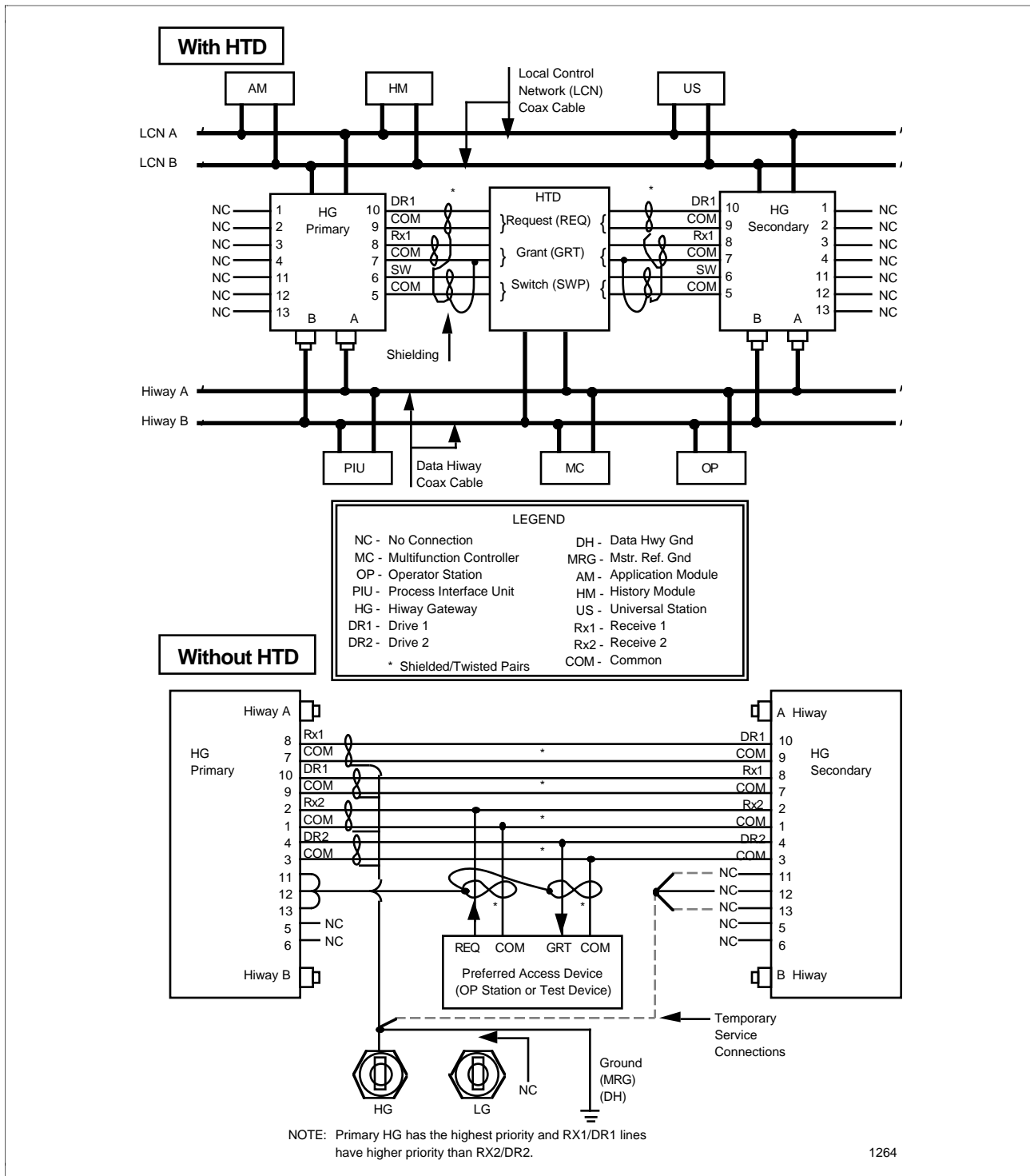

Continued on next page

5.24 Hiway Gateway Wiring, Continued

Illustration

Figure 5-16 Preferred Access Priorities—without HTD (using HG-HTD)

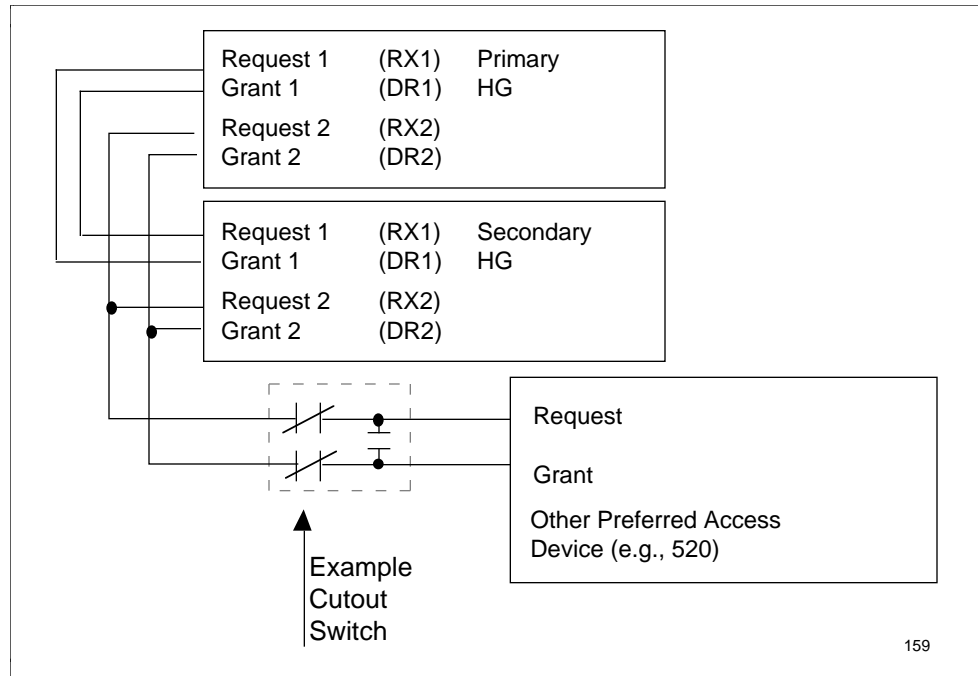

5.25 Intrinsic Safety Grounds

Zener barrier ground

When intrinsic-safety barrier-panels or boxes are added to a system, it is necessary to ensure a secure ground connection for the zener barrier. A ground wire must directly connect between each zener-barrier ground bar and the Master Reference Ground rods. Figures 5-17 and 5-18 illustrate the preferred method, which requires a separate wire for each barrier panel. Figure 5-19 shows an alternate method.

- The resistance from the barrier ground bar and the Master Reference Ground, to the Mains (ac safety) ground should be less than 1 ohm. If the resistance through earth between the Master Reference Ground and the Mains (ac-safety) ground is less than 1 ohm, this condition would normally be satisfied.
- The barrier bus-ground wire must be 2.12 mm (#12 AWG) to satisfy code requirements.
- In addition to the special zener barrier ground, the power supply is separately grounded through the PSC bar to the Local Reference bar.
- The ground wires must be protected from accidental breakage or other type of interruption.

Auxiliary devices ground

Millivolt-to-current (mV/I) model No. C-AML01 and resistance-to-current (R/I) model No. C-ARB01 auxiliaries are FM-approved intrinsically safe when connected to approved field devices. They must be installed in single cases or in a file with only intrinsically safe cards. These devices are grounded through the signal common (SC) bus and the Local Reference bar.

Continued on next page

5.25 Intrinsic Safety Grounds, Continued

Illustration

Figure 5-17 Barrier Panel C-TBU10 Ground

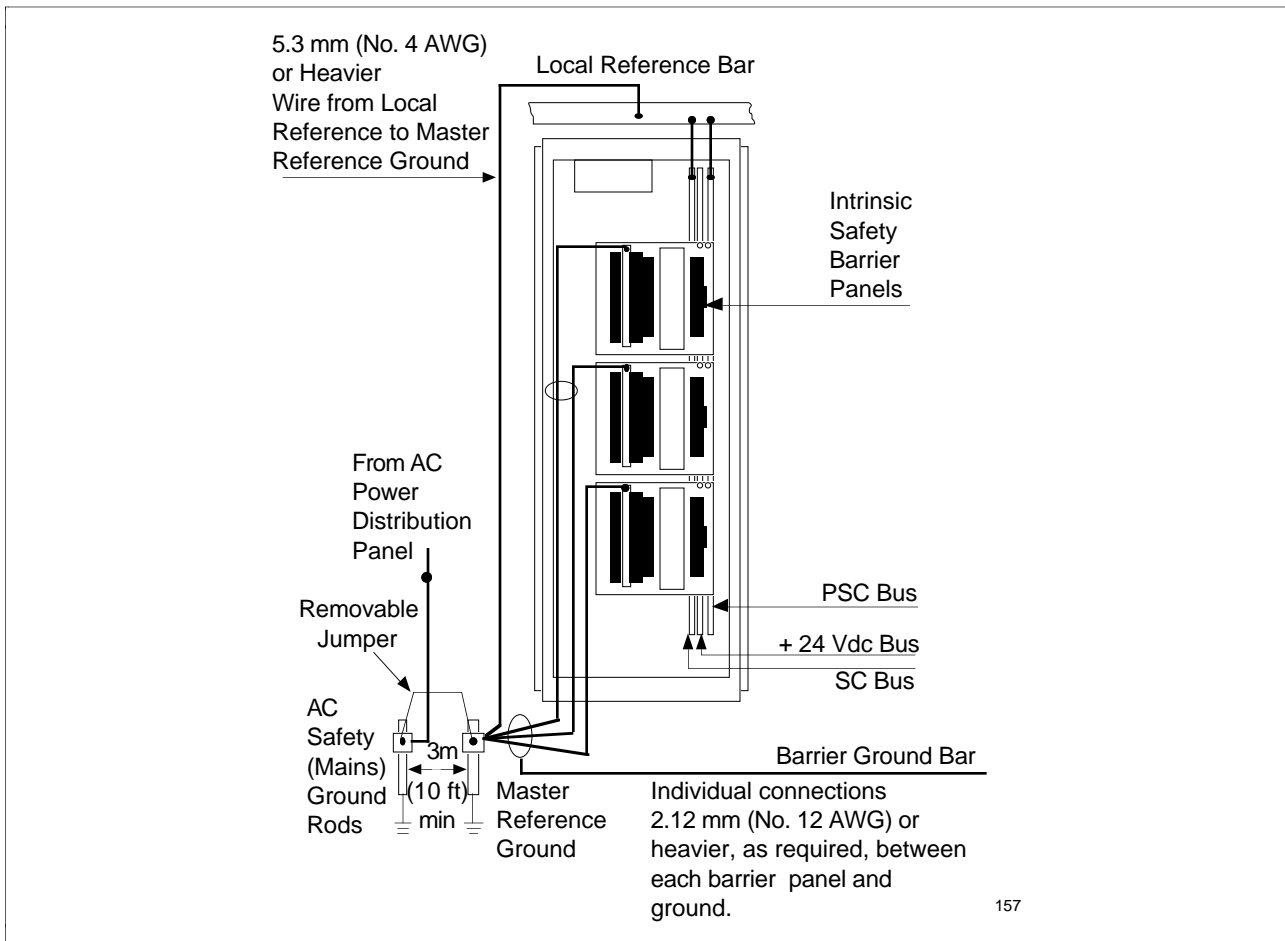

Continued on next page

5.25 Intrinsic Safety Grounds, Continued

Illustration

Figure 5-18 LEPIU Barrier Box PISBIX Ground Connector

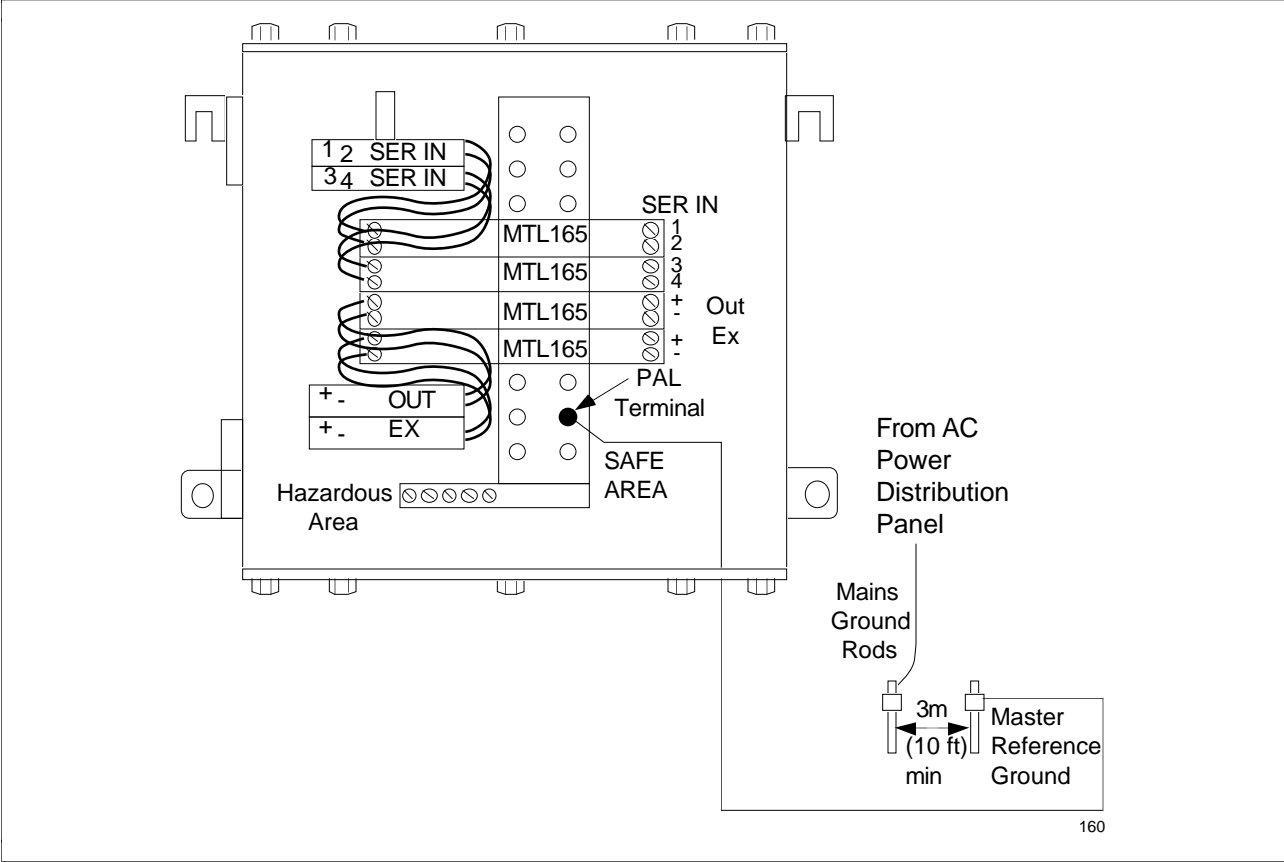

Continued on next page

5.25 Intrinsic Safety Grounds, Continued

Illustration

Figure 5-19 Alternate Zener Barrier Ground System

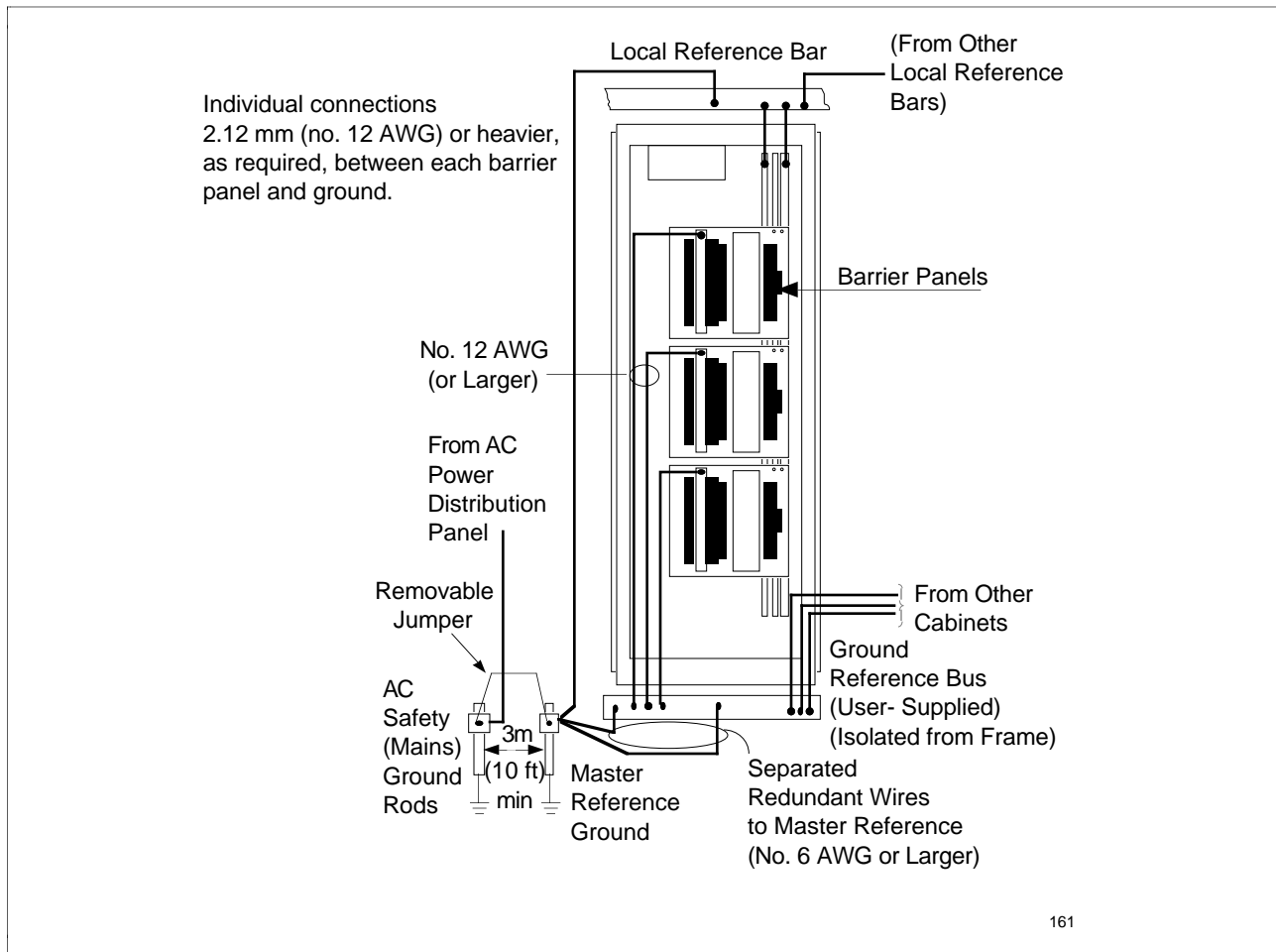

Continued on next page

5.26 High Level and Low Level PIU Ground

Safety ground

Cabinet safety-grounding is provided by the green safety-ground wire in the PSU ac-power cable. See example "G" in Appendix C.

Power supply ground

Dc power is distributed in the HL and LL PIUs through the SJA00 power junction assembly. The power junction assembly also grounds to the Master Reference Ground (Figure 5-20).

Figure 5-20 High Level and Low Level PIU Ground Connections

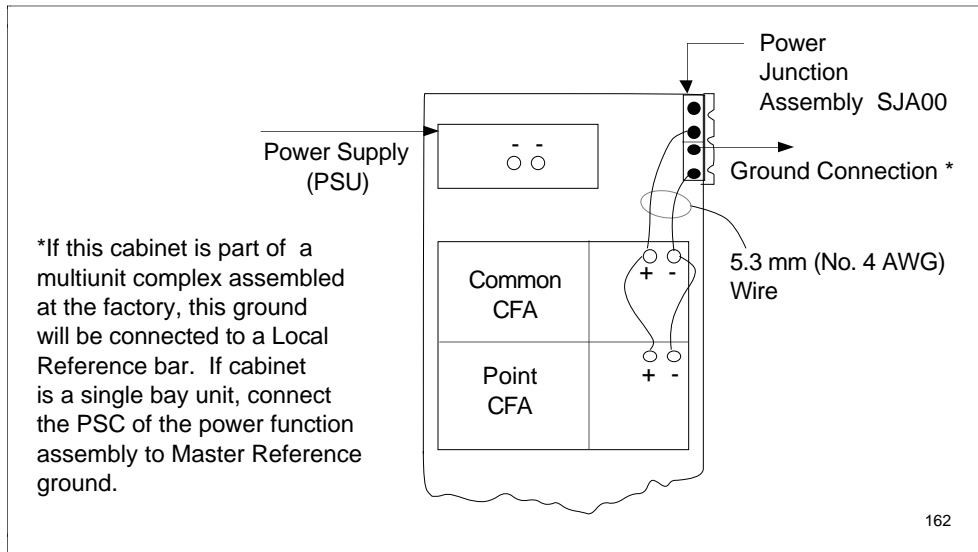

5.27 Low Energy CFA Ground

Safety Ground

Cabinet safety-grounding is provided by the green safety-ground wire in the PSU ac-power cable. See example "G" in Appendix C.

Power supply ground

The common CFA card file mounts on a back pan and is powered through bus bars.

The ground connection (Figure 5-21) is from PSC, which, in turn, is connected to the Master Reference Ground.

Figure 5-21 LEPIU CFA Ground

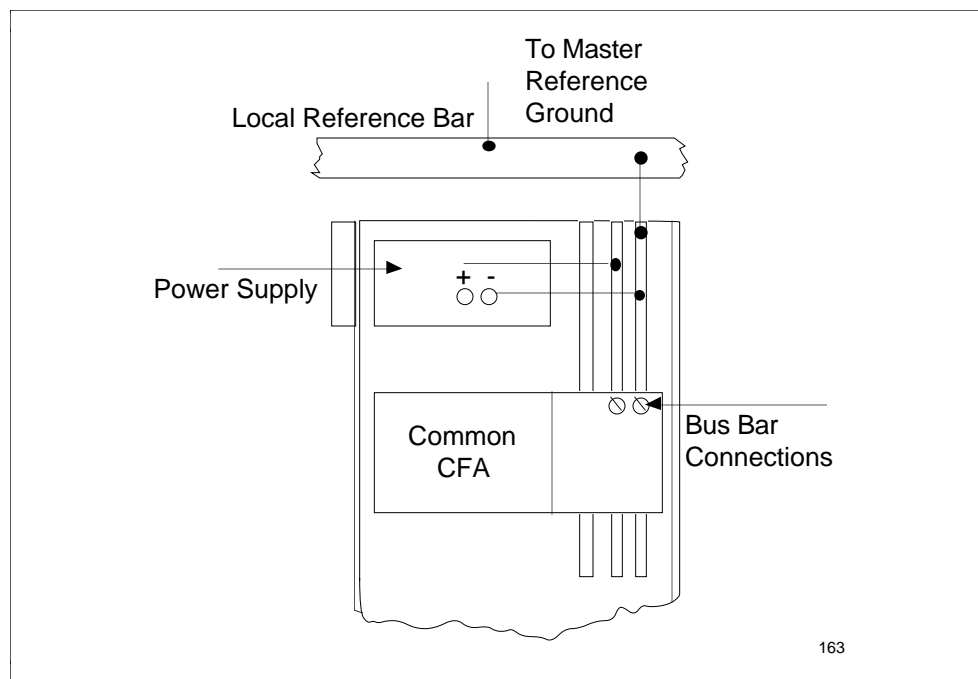

5.28 Fiber Optic Link Grounds

Guidelines

Examples F and G in Appendix C show safe grounding methods when a fiber optic link is used as an energy barrier.

- The Hiway Coupler Module (HCM) on the high-voltage side (greater than 250 volts) must be connected to a separate Master Reference Ground.
- The HCM Master Reference Ground on the intrinsically safe side must be separated from the HCM on the high-voltage side by a distance greater than 10 feet. That is, the necessary isolation is preserved by confining the HCM on the high-voltage side to a separate file, bus bars, power supply, and Master Reference Ground cable and rods.

When the short fiber optic link is used (example G), hazardous potentials must be confined to one signal tray while intrinsically safe wiring is confined to another. Or, a grounded metal barrier can be used for separation if one tray is used.

Note that either example, F or G, preferred-access wiring **MUST NOT** be taken through the classified (hazardous) area to an auxiliary operator station. The auxiliary operator station preferred-access wiring and hiway cable for that station are not isolated by an HCM, and such wiring could feed hazardous energy to the field and to remotely located controllers through the CRT of the auxiliary operator station.

5.29 Marshalling Panel Grounds

Local reference bar

Marshalling panels are grounded through the bus-bar system (Figure 5-22). Marshalling panels C-TPG00 and C-TPM02 are normally connected to a +24 Vdc bus and PSC bus. The PSC bus is connected to the Local Reference bar, which, in turn, is connected to the Master Reference Ground.

When panel C-TPM01 is connected to C-TPM02 by 50-conductor cables, it receives power from CTPM02. Circuits are also grounded through C-TPM02. When two model C-TPM02 panels are connected together by 50-conductor cables, power is not connected to either panel. The panels are not grounded.

Reference

Marshalling Systems, Cabling, Wiring, and Interconnections, TO-20-02.

Illustration

Figure 5-22 Marshalling Panel Grounds

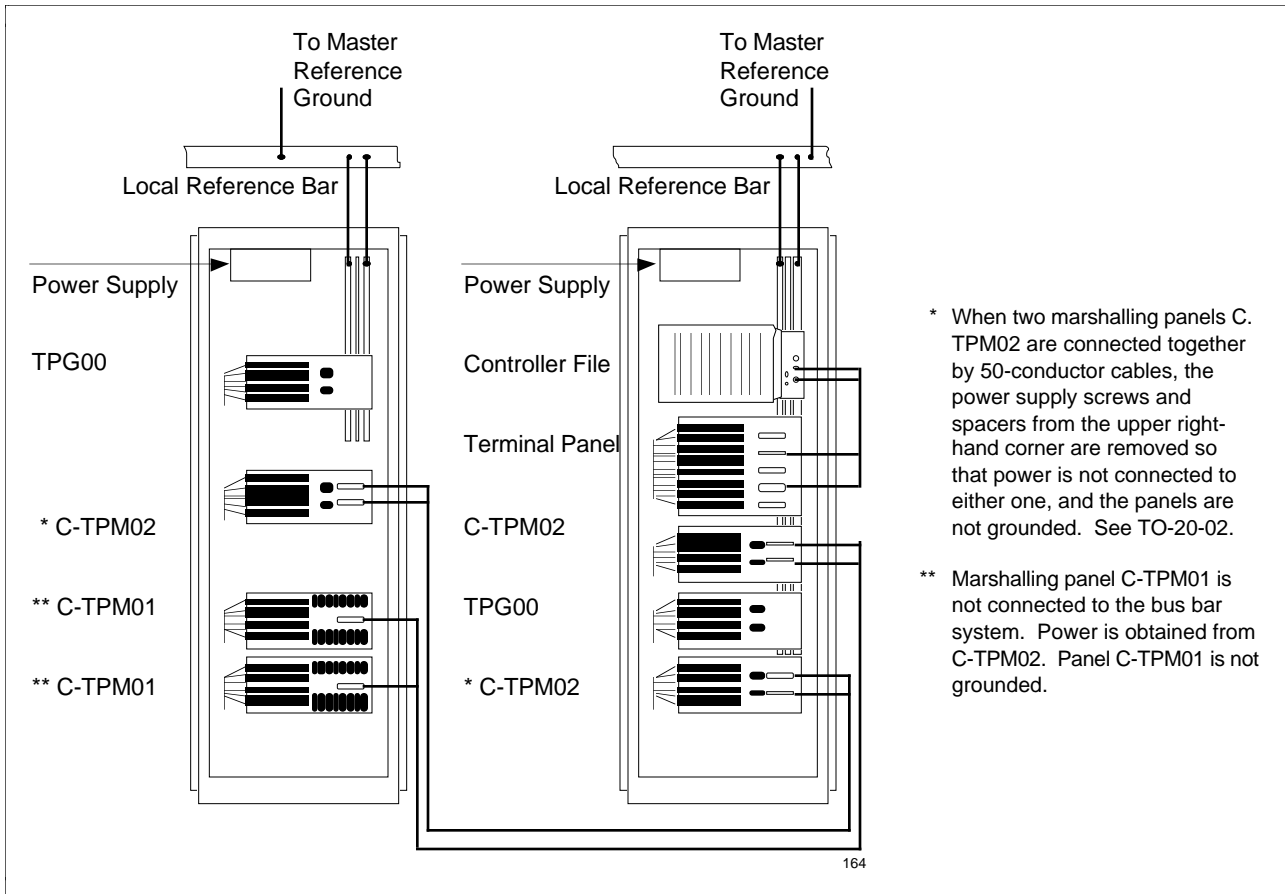

5.30 Field Device Grounds

Guidelines

Connect circuits in field-mounted devices to the appropriate ground systems.

- Connect ac sources and their safety ground.
 - Connect the common of dc signals to Master Reference Ground.
 - Make sure that all ground connections comply with manufacturer's specifications and national and local codes.
-

5.31 Grounding Summary

Typical grounding

Figures 5-22 and 5-23 show typical grounding methods for BASIC System devices. For more examples of site grounding, see Appendix C.

Wire shield grounds

Process signals are carried by twisted pairs, or in some cases, a multiconductor cable with an overall shield. All cable shields must be grounded.

- The shields of all twisted pairs that carry signals from terminal panels must be grounded at only one end. The opposite end of the shield is cut off and taped (no connections). The shield for each pair is grounded
 - at the transmitter if the transmitter includes a grounding terminal separate from the plus (+) and minus (-) terminals, or
 - at the terminal panel if the transmitter does not include a separate grounding terminal.
- All shielded, twisted pairs carrying signals to field devices from equipment will have the shield grounded at the associated minus-output (COM or PSC) terminal of the terminal or marshalling panel. The shield wire is cut off and taped (no connection) at the field-device end of the shield.
- Cables with overall shields and miscellaneous shielded cables that do not have the signal source clearly defined, should be grounded at a Local Master Reference ground. The shield wire at the far end of the cable shield is cut off and taped.

WARNING

WARNING—Do not connect cable shields that may be associated in any way with ac-safety or structural steel grounding to the Master Reference Ground system.

- Shield wires for thermocouples and resistance-temperature devices (RTDs) are normally grounded at the element itself (usually welded to the thermowell). Likewise, thermocouple receivers, such as LEPIU, MV/I, etc., have their shields connected at the receiver's end.
- Intrinsically safe systems require that field shields be connected to the barrier-panel-grounding terminal. (The other grounding rules outlined here also apply.)

ATTENTION

ATTENTION—All ground connections should be able to meet supplier's recommendations and comply with local and national codes.

Continued on next page

5.31 Grounding Summary, Continued

Illustration

Figure 5-23 Typical Grounding Methods

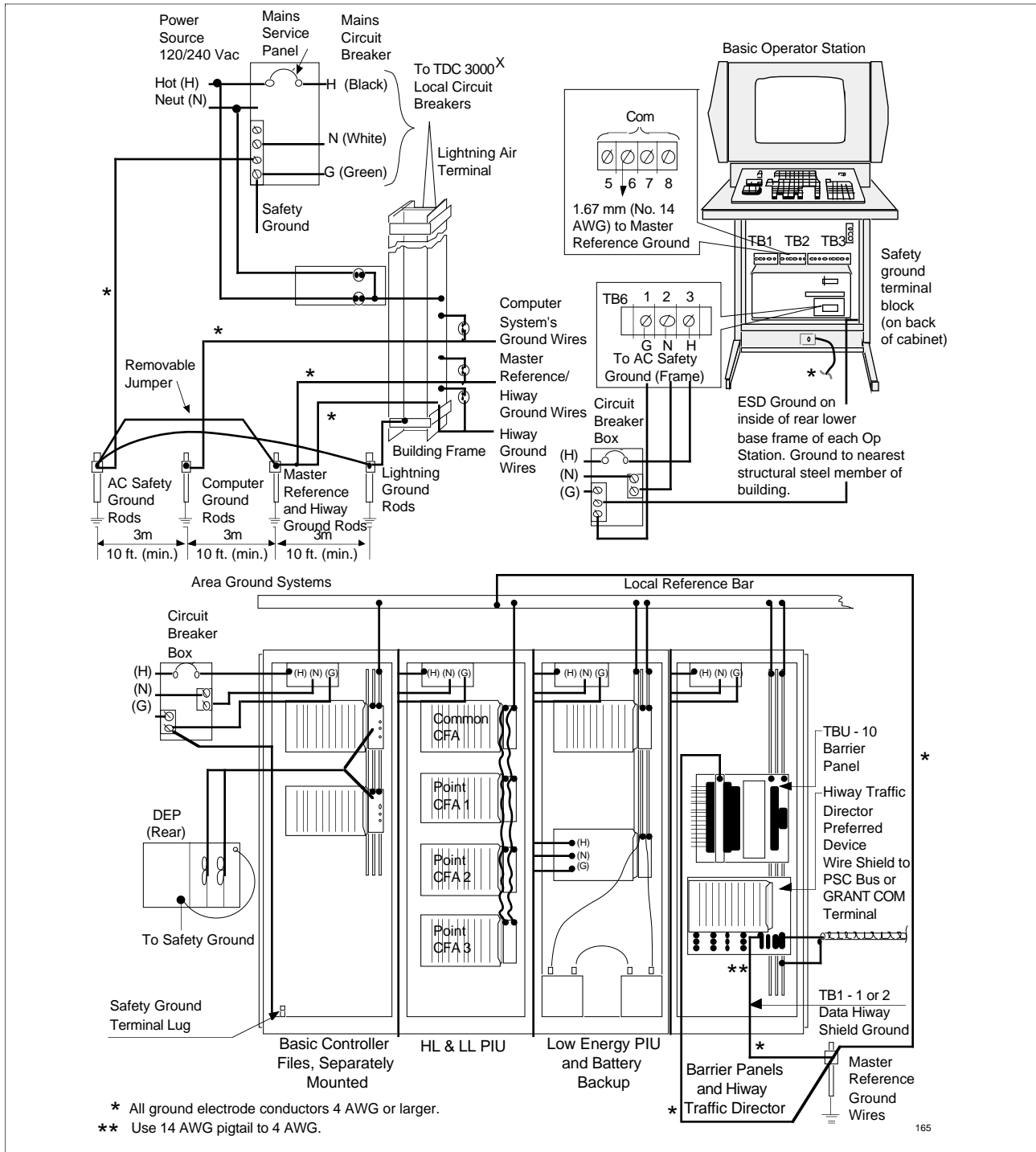

Continued on next page

5.31 Grounding Summary, Continued

Illustration

Figure 5-24 Typical Grounding Methods

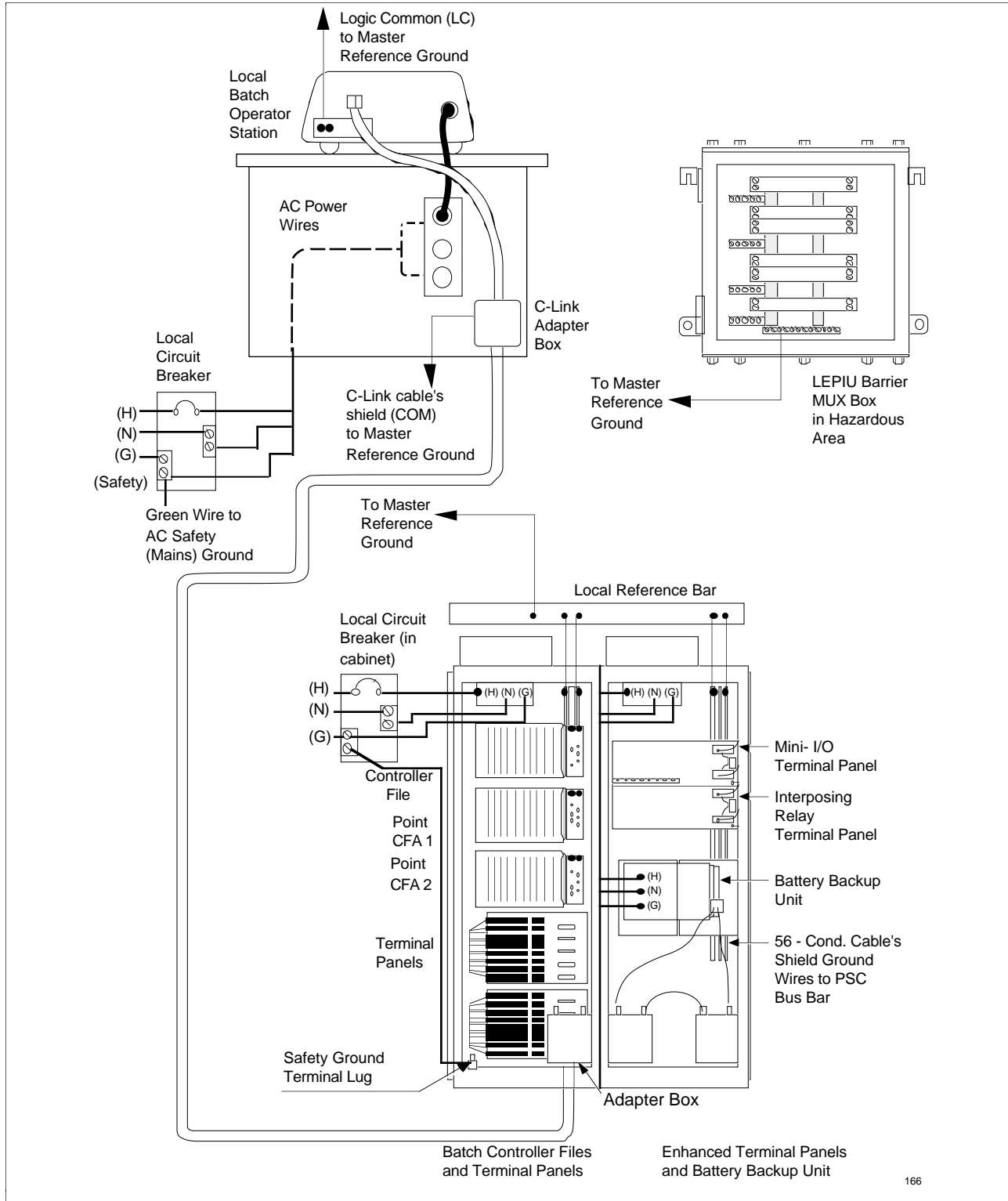

166

Appendix A – Consoles and Cabinets

A.1 Overview

Section contents

These are the topics covered in this section:

	Topic	See Page
A.1	Overview.....	141
A.2	Upright Cabinets.....	142
A.3	BASIC Cabinet Cable Routing.....	143
A.4	Operating Center Console.....	144
A.5	Console Development for Layout.....	145
A.6	LCN Style Console.....	146
A.7	Basic System Layout Templates.....	147
A.8	Remote Multiplexer Box	154
A.9	Barrier Box.....	155
A.10	LEPIU Layout Information.....	156
A.11	TDC 3000X Sample Layout for Hazardous Areas.....	157

A.2 Upright Cabinets

Cabinet Dimensions

Honeywell TDC 3000^X BASIC System standard cabinets are shown in this section. Dimensions shown are actual overall dimensions. System cabinets are also available in groups of up to five cabinets. When more than one cabinet is used in a grouping, the frame dimensions are additive.

Illustration

Figure A-1 Upright Cabinet Dimensions

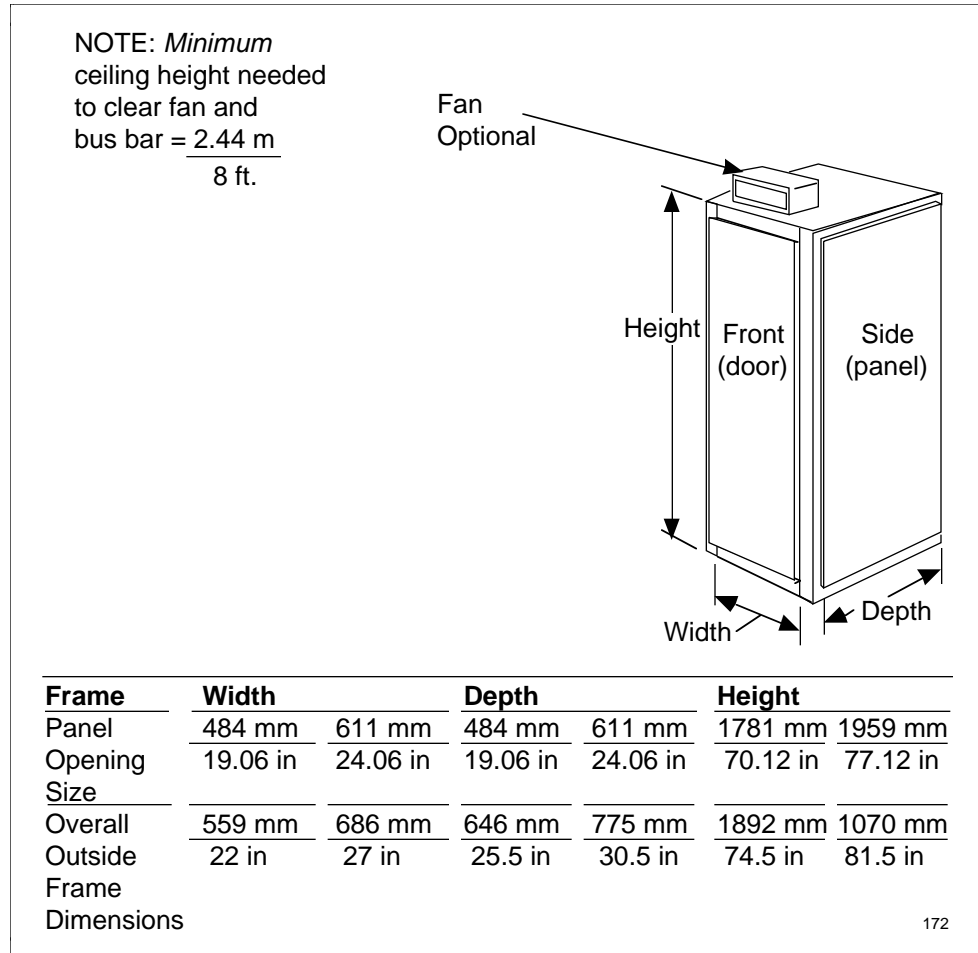

Doors

The front and rear hinged doors swing 90 degrees to the left. Doors are easily removed by disconnecting the door stop lanyard and pulling the top spring-latch.

A.3 BASIC Cabinet Cable Routing

Description

Figure A-2 illustrates wiring in the cabinet. Field wires to a terminal panel go the left side in a 2-inch raceway fastened to the backplate mounting brackets. Wires are routed through the slots in the side of the raceway to each terminal panel.

Figure A-2 BASIC Cabinet Wire Routing

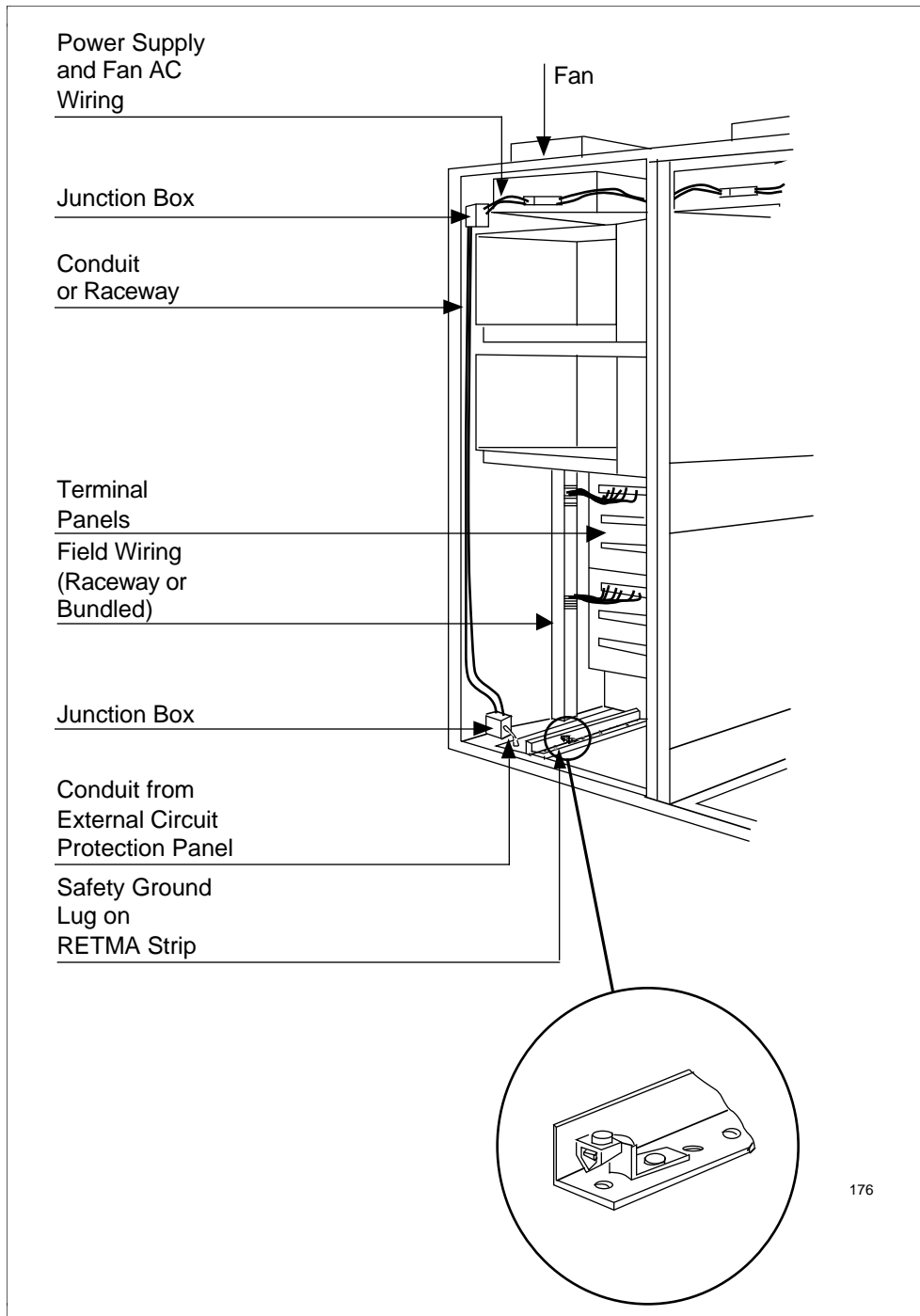

A.4 Operating Center Console

Console base cabinets

The foundation of an operator station or operating center is the base cabinet. Up to five cabinets can be bolted together to form a one to five bay operating center. Leveling feet are provided or cabinets can be directly bolted to the floor.

Wedge units

Wedge units are available as basic building blocks for operating center console design. Additional table top(s) completes the modular design.

Illustration

Figure A-3 Console Base and Wedge Units

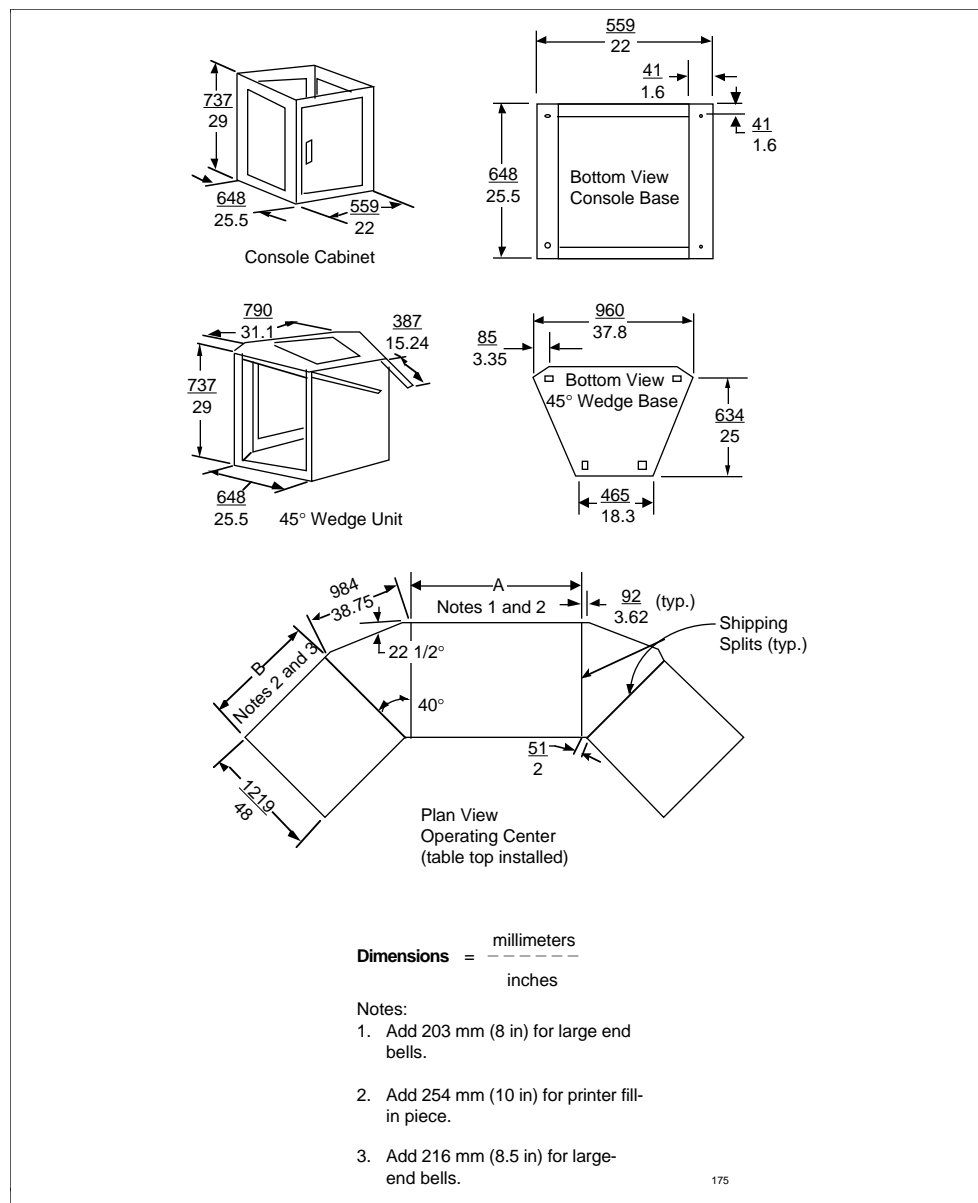

A.5 Console Development for Layout

**Layout
development**

Development of the console basic building blocks is shown in Figure A-3. Table tops are added and shipping splits are indicated.

ATTENTION

ATTENTION—Refer to order approval documentation for final dimensions.

A.6 LCN Style Console

Illustration

Figure A-4 New Style Console in LCN Furniture

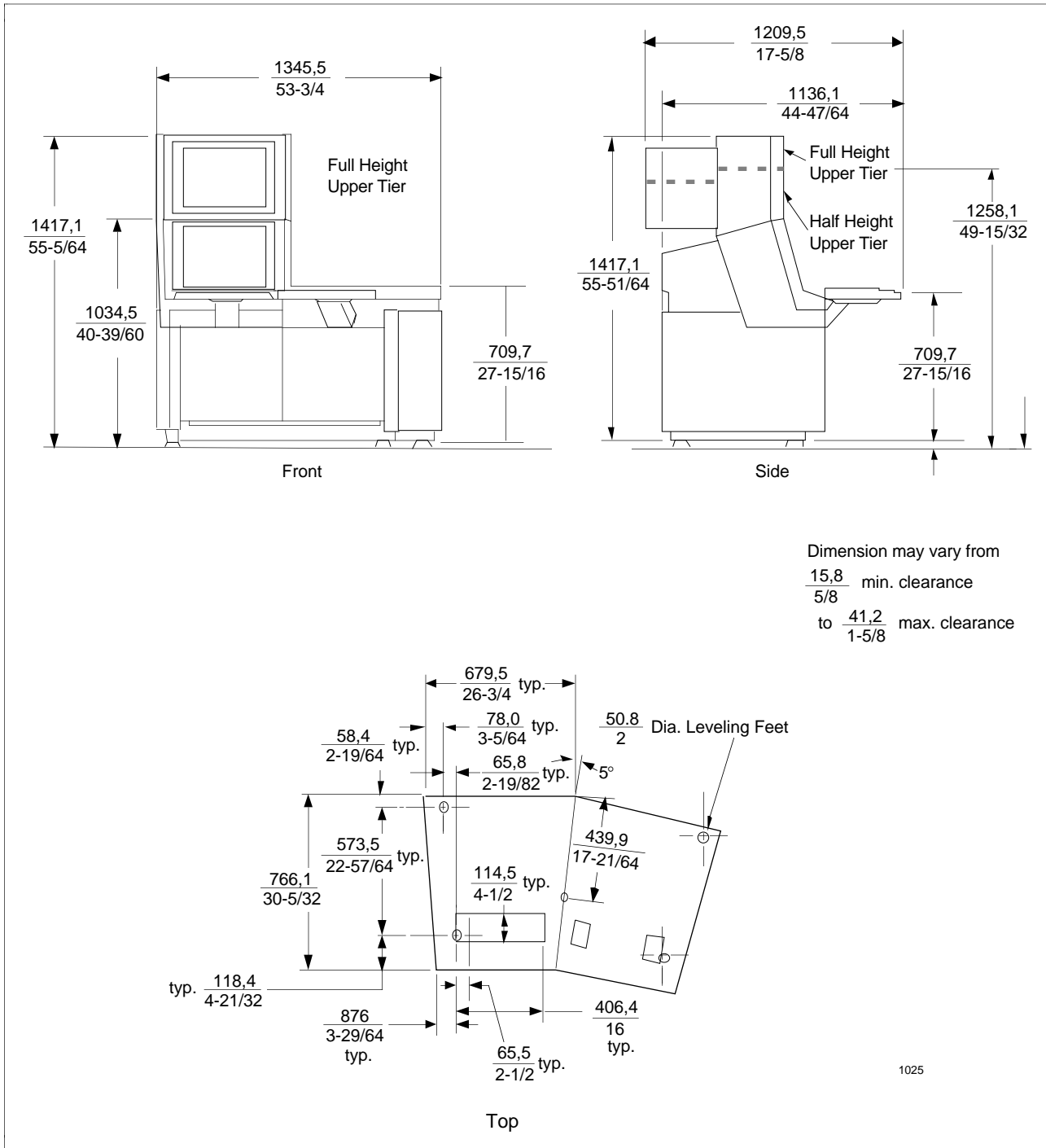

A.7 Basic System Layout Templates

Template

Figure A-5 BASIC System Layout Template #1

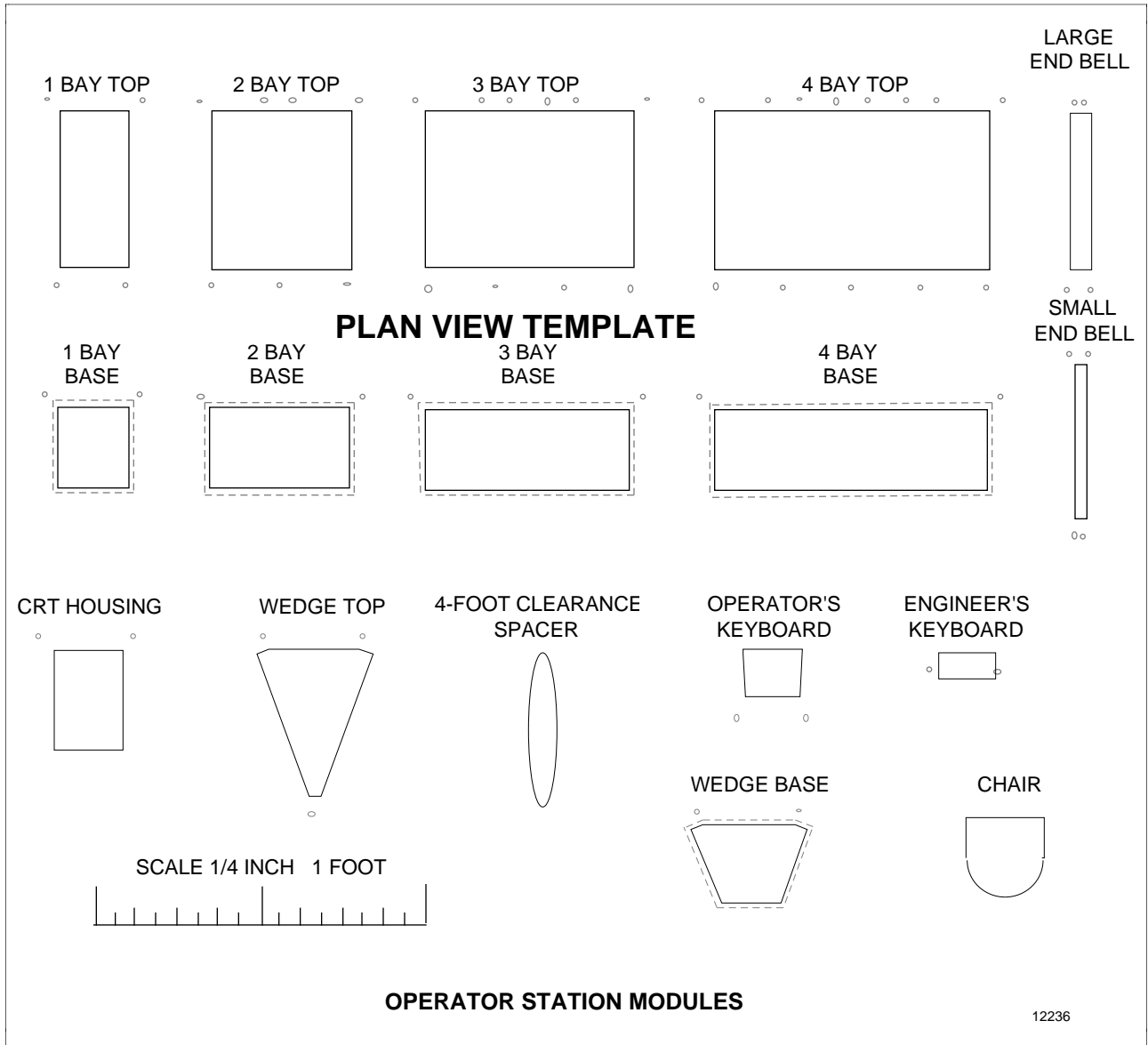

Continued on next page

A.7 Basic System Layout Templates, Continued

Template, continued

Figure A-6 BASIC System Layout Template #2

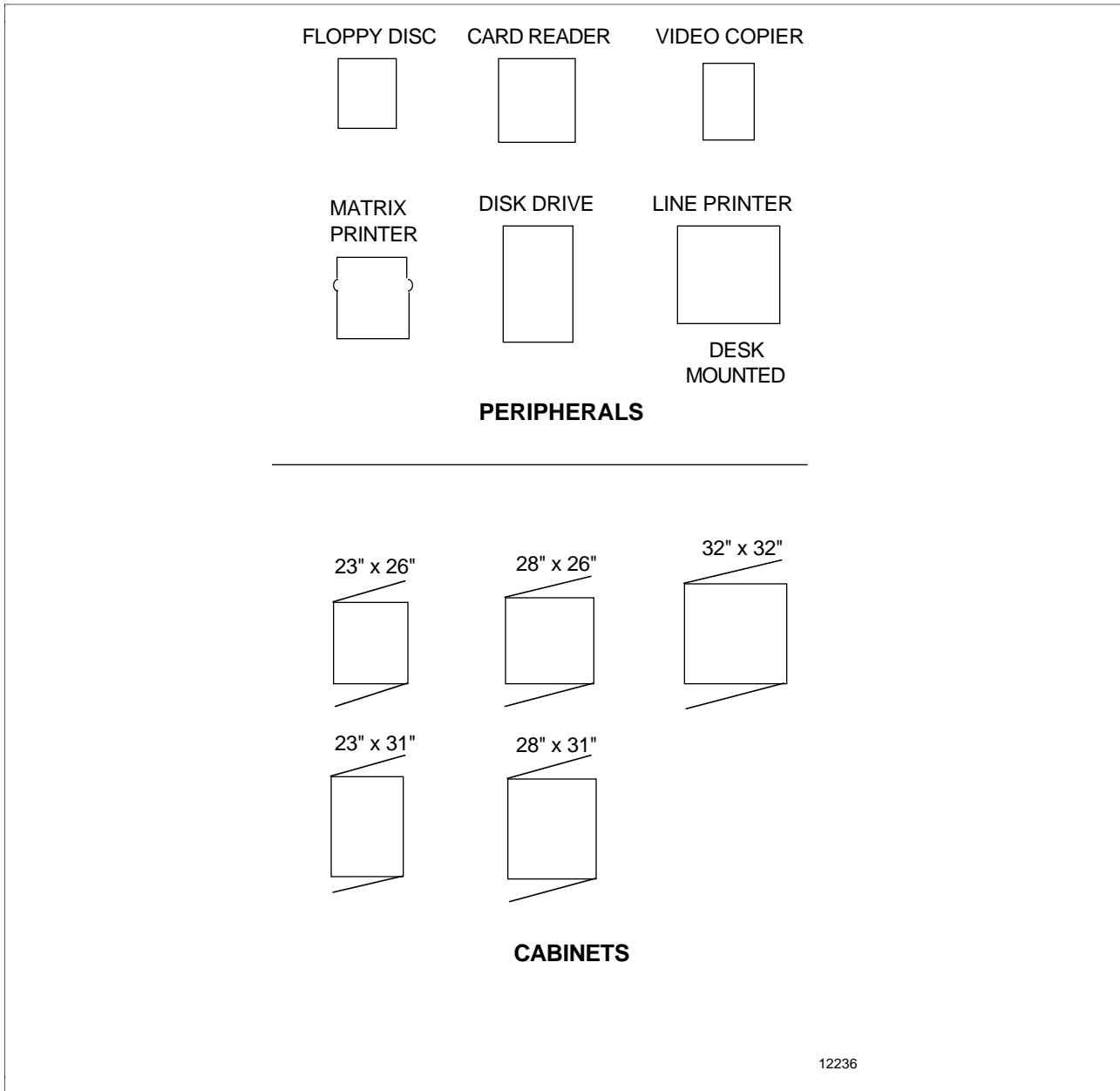

Continued on next page

A.7 Basic System Layout Templates, Continued

Template, continued

Figure A-7 BASIC System Layout Template #3

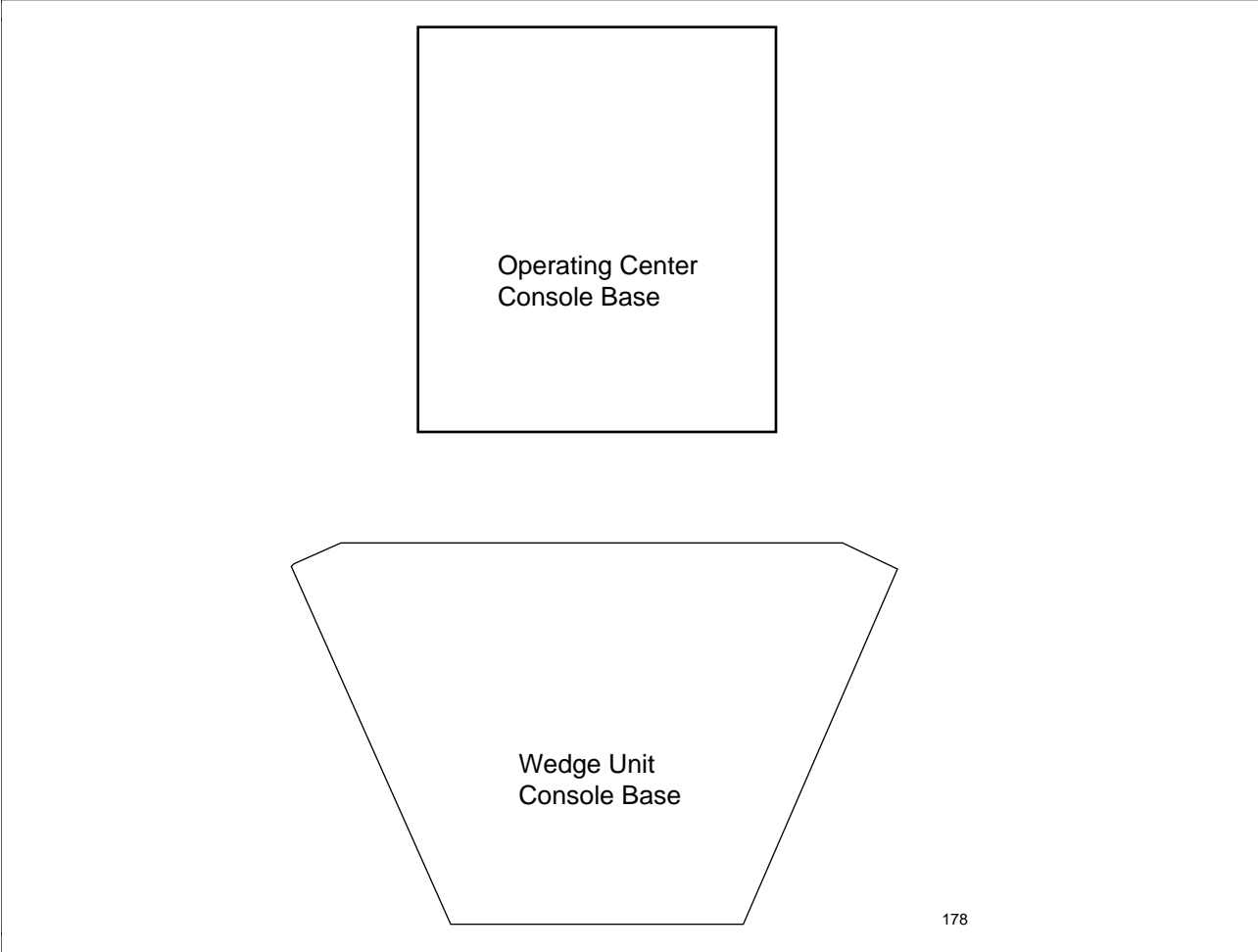

Continued on next page

A.7 Basic System Layout Templates, Continued

Template, continued

Figure A-8 BASIC System Layout Template #4

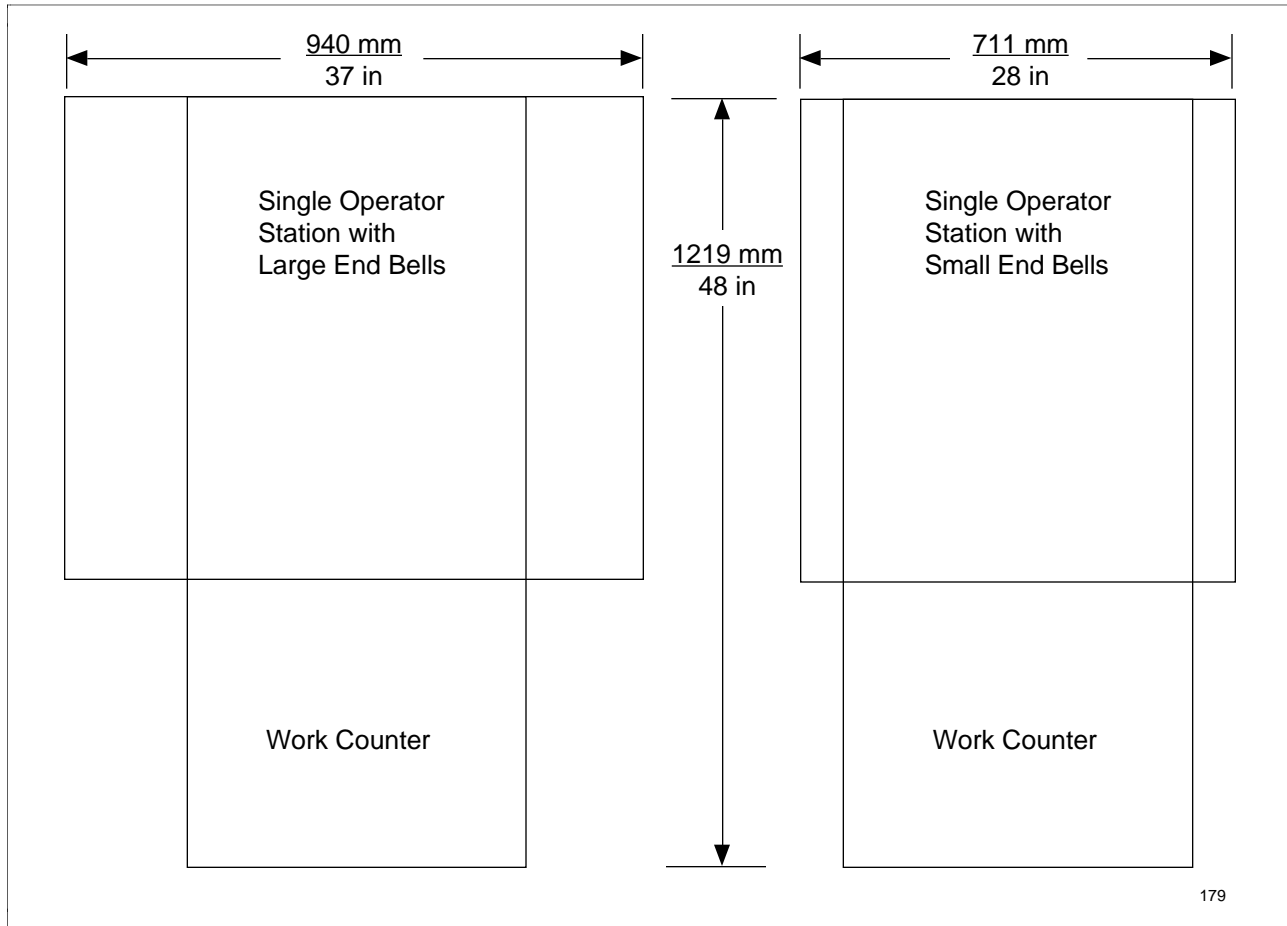

Continued on next page

A.7 Basic System Layout Templates, Continued

Template, continued

Figure A-9 BASIC System Layout Template #5

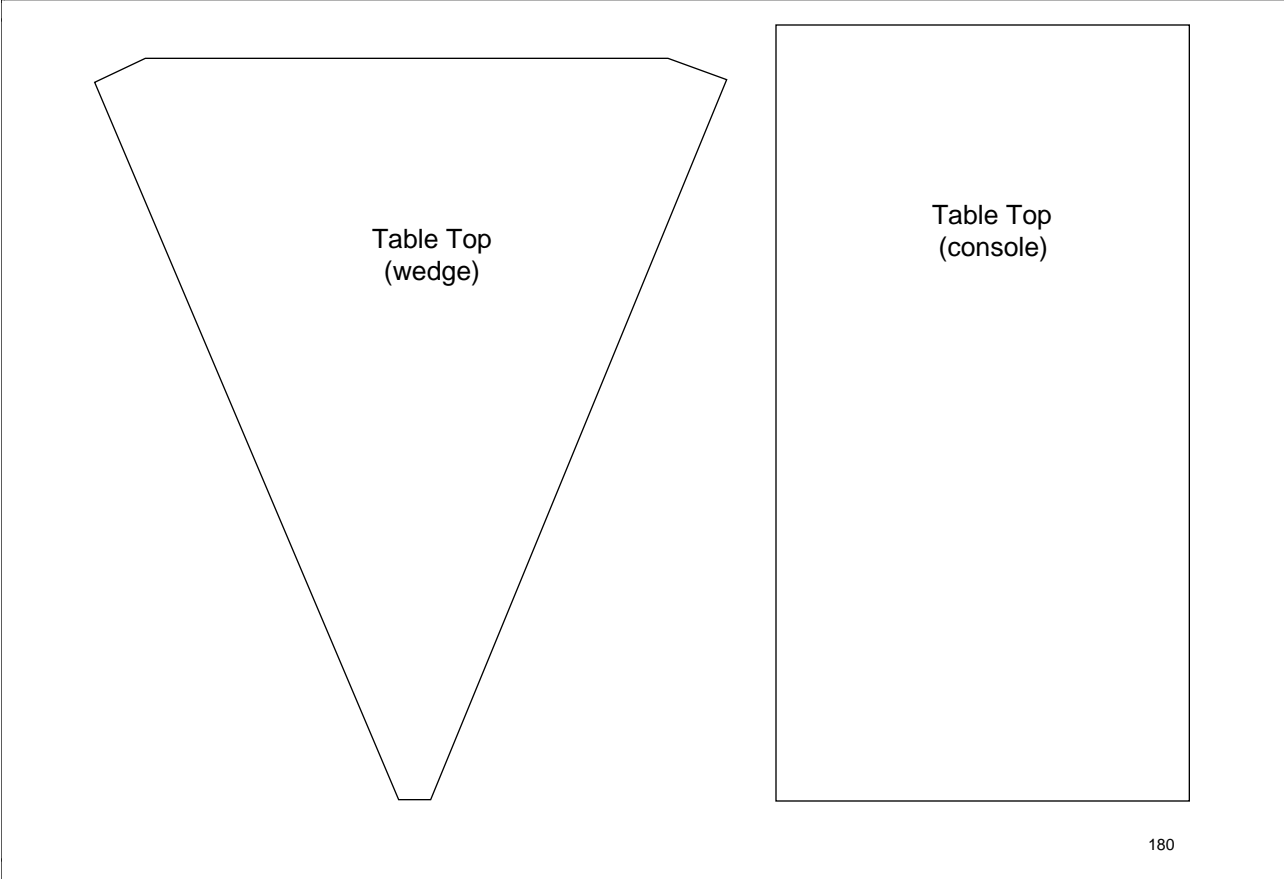

Continued on next page

A.7 Basic System Layout Templates, Continued

Template, continued

Figure A-10 BASIC System Layout Template #6

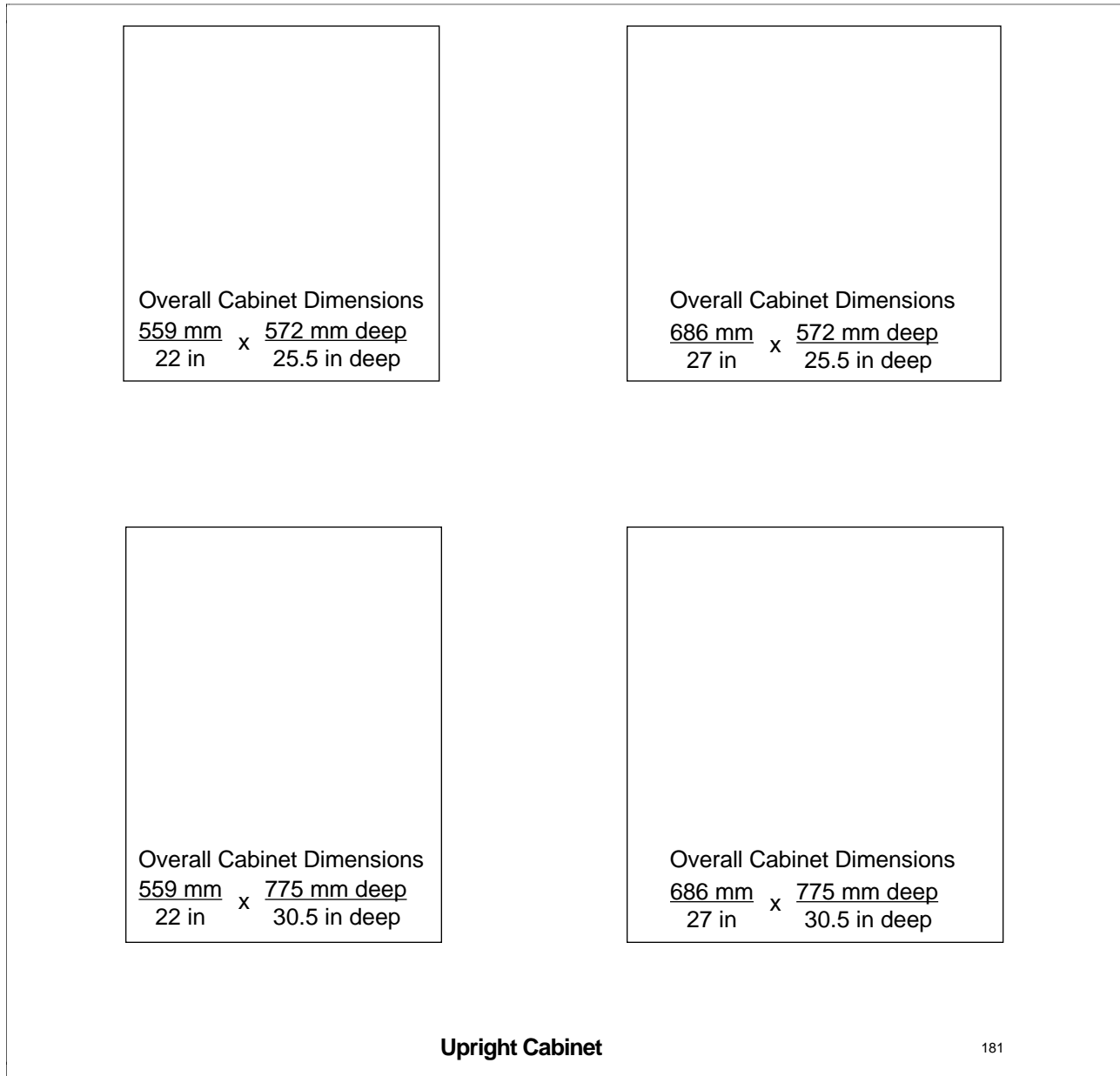

Continued on next page

A.7 Basic System Layout Templates, Continued

Template, continued

Figure A-11 New Style Consoles

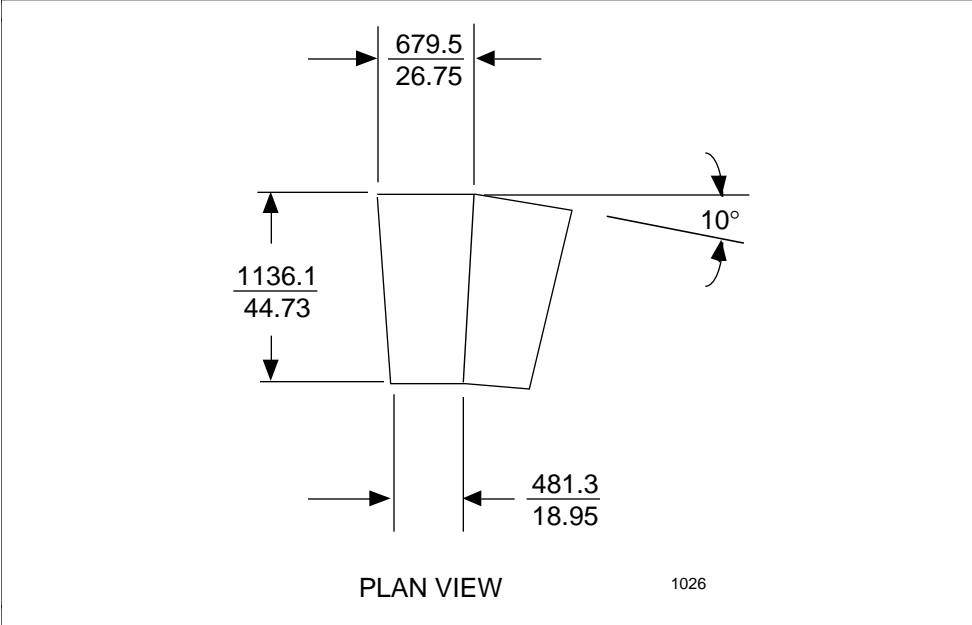

A.8 Remote Multiplexer Box

Specifications

Figure A-12 Dimension and Specifications for Remote Multiplexer Box

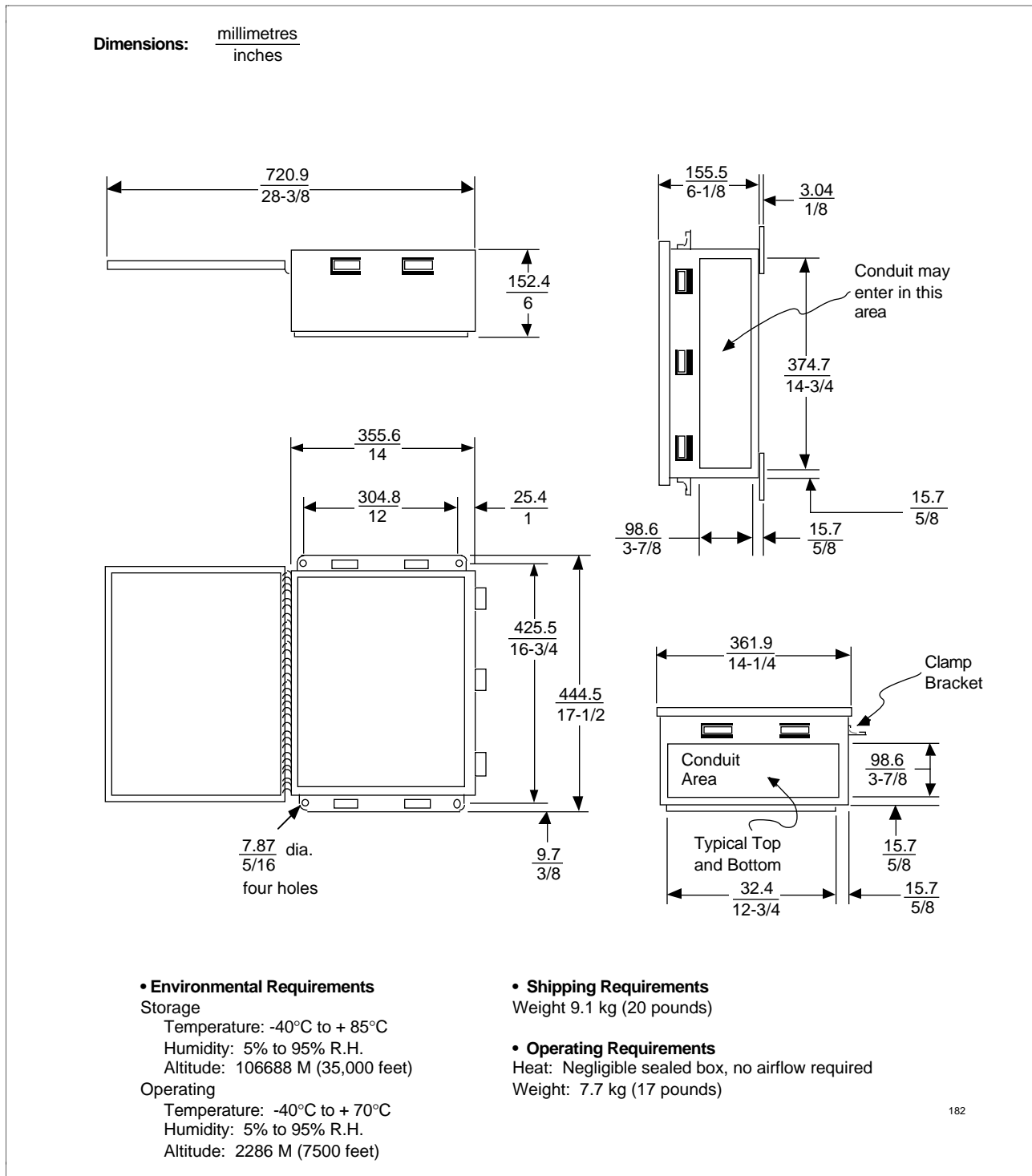

A.9 Barrier Box

Specification

Figure A-13 Dimension and Specifications for Remote Multiplexer Box

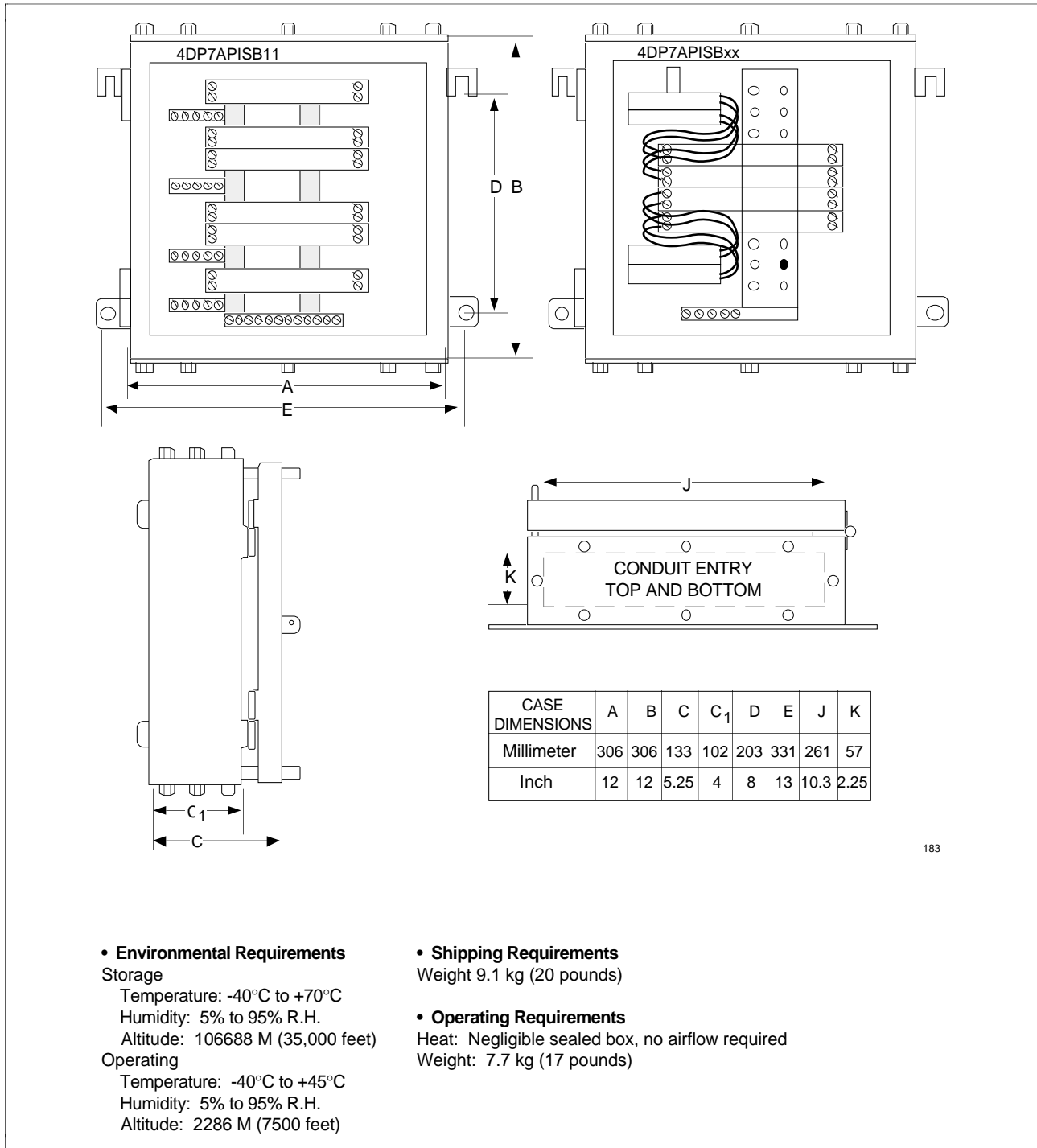

A.10 LEPIU Layout Information

Specification

Figure A-14 LEPIU Cabling

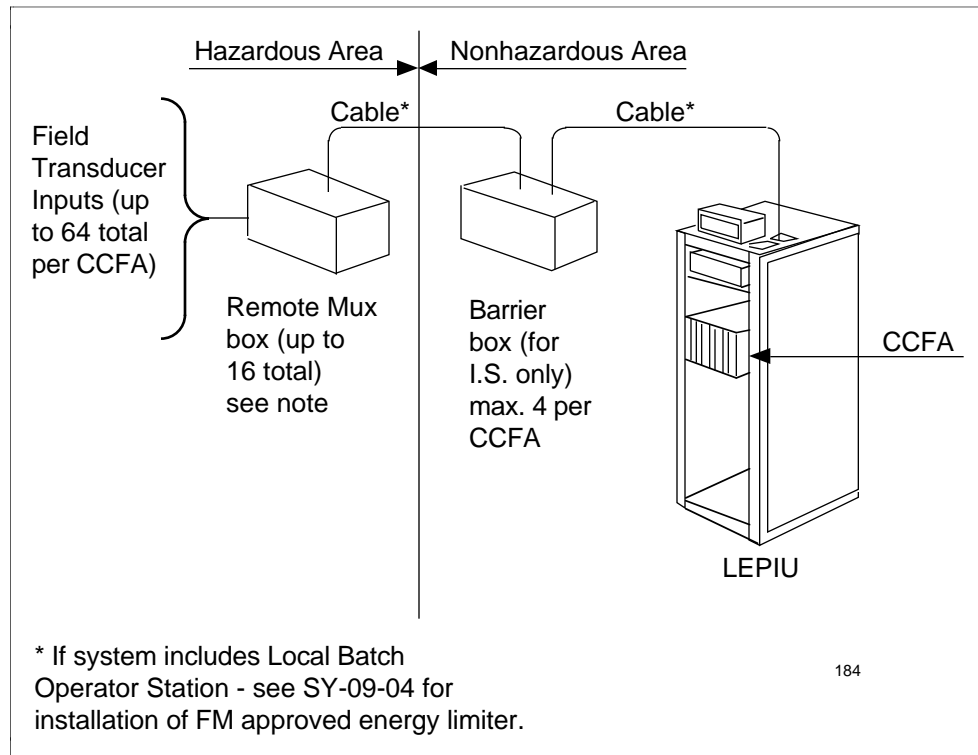

A.11 TDC 3000X Sample Layout for Hazardous Areas

Illustration

Figure A-15 TDC 3000X Sample Layout for Hazardous Areas

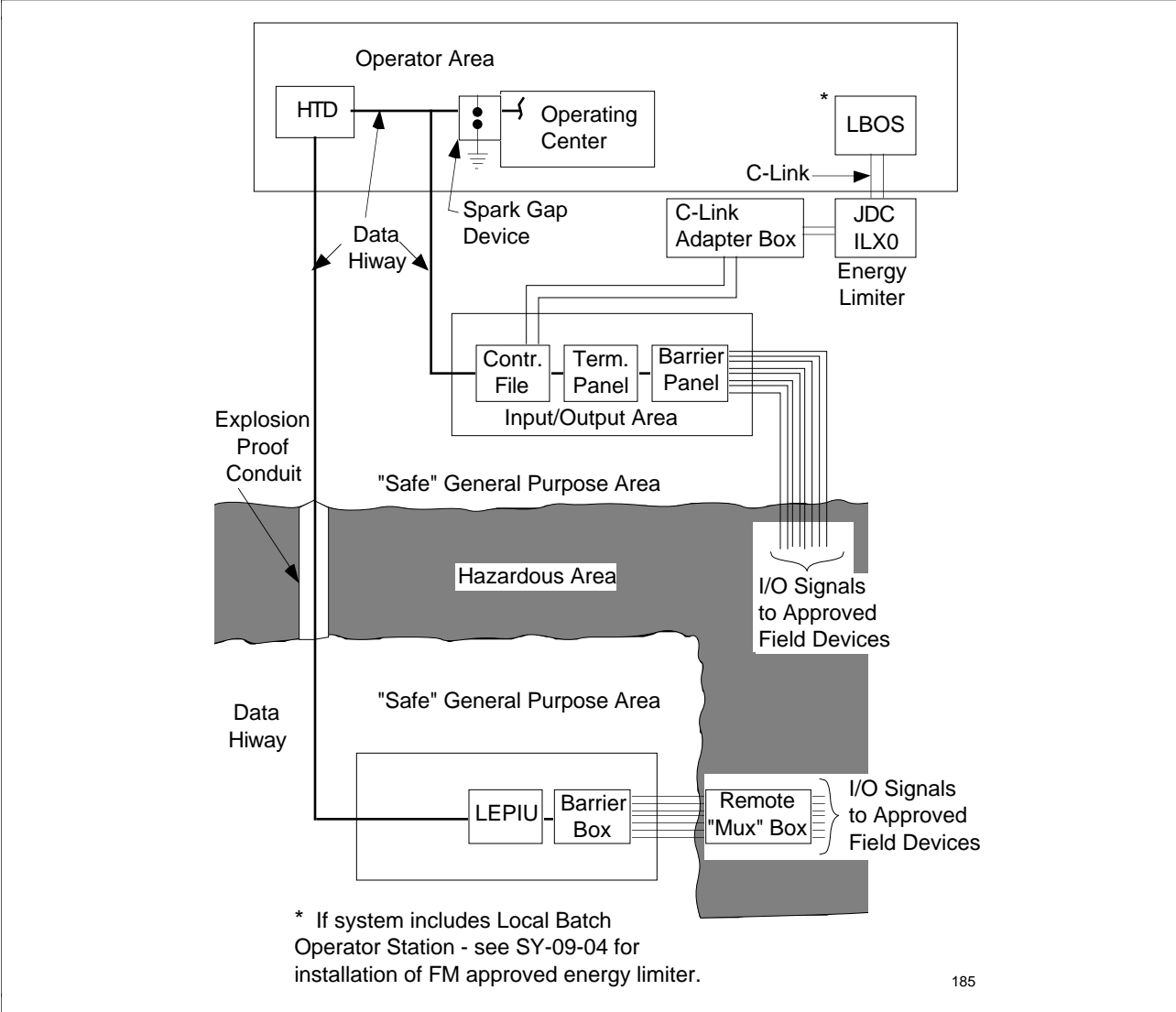

Appendix B – Power Requirements for BASIC Equipment

B.1 Overview

Section contents These are the topics covered in this section:

Topic		See Page
B.1	Overview.....	159
B.2	Basic Systems Power Requirements.....	160
B.3	Basic Power Supplies.....	170
B.4	Advanced Multifunction Controller (A-MC) Modules.....	171

Scope

The data in the following tables are required to size electrical service components such as Uninterruptible Power Systems (UPSs), transformers, breakers, and wire size.

B.2 Basic Systems Power Requirements

Specification

Table B-1 Basic System Power Requirements—Operator Interface

Basic and Multifunction Controller		Line Freq	RMS Input Volts	True RMS Amps	Avg RMS Amps	AC Inrush Amps	Line Power Watts	Crest Factor	Power Factor	Disipated BTUs/Hr
Model #	Description	Hz								
C-DSB01	Op Stn w/ cassette drive	60	115		5.7	125.0	528.0			1805.3
C-DSB45; C-DSB46	Op Stn w/ single disk drive	60	105		6	125.0	470.0			1607.1
		60	115		5.4		470.0			1607.1
		60	220		2.9		470.0			1607.1
		60	240		2.7		470.0			1607.1
DSB51	Op Stn (No disk drv or CRT)	60	105		5.64		426.0			1457.0
		60	115		5.06		426.0			1457.0
		60	220		2.67		426.0			1457.0
		60	240		2.49		426.0			1457.0
DSB53	Op Stn (No disk drv or CRT)	60	105		6.12		482.0			1648.0
		60	115		5.64		482.0			1648.0
		60	220		2.87		482.0			1648.0
		60	240		2.69		482.0			1648.0
C-DSB68; C-DSB56	EOS/BOS w/ Dual disk	60	102		3.7	62.5	322.0			1099.4
	Drive & w/ Monitor	60	110		3.7		347.0			1184.7
		60	115		3.8		365.0			1246.2
		60	120		3.8		382.0			1304.2
VDM33	Monitor	60								
C-DSM02	Monitor	60	115		1.3	6.0	125.0			426.8

Continued on next page

B.2 Basic Systems Power Requirements, Continued

Specification,
continued

Table B-1 Basic System Power Requirements—Operator Interface, continued

Basic and Multifunction Controller		Line Freq	RMS Input Volts	True RMS Amps	Avg RMS Amps	AC Inrush Amps	Line Power Watts	Crest Factor	Power Factor	Dissipated BTUs/Hr
A-VMD11	Color 19 in monitor	60	105		1.0		170.0			580.4
		60	115		1.0		170.0			580.4
		60	220		0.5		170.0			580.4
		60	240		0.5		170.0			580.4
C-DELO0	Energy Limiter (color)	60								
C-DSP10	1000 Point Expansion	60								
J-DCLX0	Energy Limiter	60	100-220							
DSP40/41	Line Printer	60	115		-2.0	3.3	104.0			355.1
C-DSP30	Video Copier (B&W)	60	115		2.3	7.2	240.0			819.4
C-DPD20	Data Entry Panel	60	24		2.1	NA	50.4			172.1
C-DPX20	Slot Selector	60	24		0.14	NA	3.4			11.6
DSD5X	Disk Drive (sgl or dual)	50	105		0.48		44.0			150.2
DSD5X	Disk Drive (sgl or dual)	50	115		0.36		44.0			150.2
DSD6X	Disk Drive (sgl or dual)	60	220		0.23		44.0			150.2
DSD6X	Disk Drive (sgl or dual)	60	240		0.21		44.0			150.2

Continued on next page

B.2 Basic Systems Power Requirements, Continued

Specification,
continued

Table B-2 Basic System Power Requirements—DC Power

Basic and Multifunction Controller DC Power		DC Input Volts	DC Amps	MAX DC Amps	DC Inrush Amps	Line Power Watts	Dissipated BTUs/Hr
Model #	Description						
C-CB0XX	Basic Controller	24	2.2	N/A	52.8		180.3
C-CD000	Reserve Controller Director	24	4	N/A	96		327.8
C-HCB01	CB/Hiway Interface	24	0.75	N/A	18		61.5
C-CBM00	Trend Card	24	0.5	N/A	12		41.0
C-CBM01	CMOS card	24	0.17	N/A	4.1		14.0
C-CB20X	Extended Controller	24	2.4	N/A	57.6		196.7
C-CD200	Reserve EC Director	24	4	N/A	96		327.8
C-CDD00	Digital I/O Switch File	24	0.14	N/A	3.4		11.6
C-CDS20	Digital I/O Switch Cards	24	0.05	N/A	1.2		4.1
C-DP200	DEP Card	24	0.08	N/A	1.9		6.5
C-DP201	DIDEPI Card	24	0.1	N/A	2.4		8.2
C-HCB20	Extended Controller Int.	24	0.5	N/A	12		41.0
C-CA000	Analog Unit	24	2.5	N/A	60		204.8
C-CAC00	Output Card	24	0.33	N/A	8		27.3
DSC31	LBOS	24	4	N/A	65.3		222.9
CB530	Batch Controller File	24	2.5	N/A	60		204.8
CBM52	CMOS Memory Card 8K	24	0.32	N/A	7.68		26.2
CBM53	CMOS Memory Card 16K	24	0.32	N/A	7.68		26.2
CBM54	CMOS Memory Card 24K	24	0.32	N/A	7.68		26.2
CBC00	I/O Bus Control Card	24	0.49	N/A	11.8		40.3
CBC03	C-Link Control Card	24	0.53	N/A	12.7		43.4
CBC50	Uac Interface Card	24	0.78	N/A	18.7		63.8
HCB52	Hiway Int. (Dual) Cards	24	0.84	N/A	20.2		69.0
CD500	Res. Batch Cont. Director	24	3.4	N/A	81.6		278.6

Continued on next page

B.2 Basic Systems Power Requirements, Continued

Specification,
continued

Table B-2 Basic System Power Requirements—DC Power, continued

Basic and Multifunction Controller		DC Input Volts	DC Amps	MAX DC Amps	DC Inrush Amps	Line Power Watts	Dissipated BTUs/Hr
Model #	Description						
CDS00	Switch Card (Analog)	24	0.15	N/A	3.6		12.3
CBC03	C-Link Interface	24	0.53	N/A	12.7		43.4
CDM50	Backup Memory File	24	0.5(3)	N/A	12		41.0
CBM55	Backup Memory Card	24	0.5	N/A	12		41.0
CDD50	I/O Bus Switch File	24	1.3(3)	N/A	31.2		106.5
CDS50	I/O Bus Card	24	0.14	N/A	3.4		11.6
JDP00	SO Distribution Panel						
JDR00	Primary Junction Panel						
JDR00	Reserve Junction Panel	24	0.4	N/A	8.4		28.7
SO Junction Panel							
JDD50	Primary	24	0.2	N/A	4.2		14.3
JDD51	Reserve	24	0.4	N/A	8.4		28.7
Point Card File							
PF100	No Analog Input	24	0.6	N/A	14.4		49.2
PF200	w/ Analog Input	24	0.91	N/A	21.8		74.4

Continued on next page

B.2 Basic Systems Power Requirements, Continued

Specification,
continued

Table B-3 Basic System Power Requirements—Auxiliaries

Basic and Multifunction Controller		DC Input Volts	DC Amps	MAX DC Amps	DC Inrush Amps	Line Power Watts	Dissipated BTUs/Hr
Model #	Description						
C-AF000	Auxiliary File	24	N/A		N/A	0	0
C-AC100	Single Unit Case	24	N/A		N/A	0	0
C-AA100	Alarm Single	24	0.1		N/A	2.4	8
C-AA101	Alarm Single w/ Relay	24	0.24		N/A	5.8	20
C-AA200	Alarm Dual	24	0.12		N/A	2.9	10
C-AA201	Alarm Dual w/ Relay	24	0.26		N/A	6.3	22
C-AZL01	Integrator Linear	24	0.15		N/A	3.6	12
C-AZS01	Integrator Square Root	24	0.15		N/A	3.6	12
C-APM00	Adder/Subtractor	24	0.07		N/A	1.7	6
C-AMH00	MV/I (10-50 mV)	24	0.25		N/A	6	20
C-AML01	MV/I (2-100 mV) FM & CSA	24	0.25		N/A	6	20
C-AML02	MV/I (2-100 mV) BASEEFA	24	0.25		N/A	6	20
C-AML03	MV/I (2-100 mV) PTB	24	0.25		N/A	6	20
C-AXD00	Multiplier/Divider	24	0.11		N/A	2.7	9
C-ASD00	Signal Isolator	24	0.36		N/A	8.7	30
C-ASL00	Signal Limiter	24	0.2		N/A	4.8	16
C-AEX01	Square Root Ext.	24	0.1		N/A	2.4	8
C-ASC00	Signal Selector/Scale&Bias	24	0.18		N/A	4.4	15
C-ARB01	R/I (FM and CSA)	24	0.3		N/A	7.2	25
C-ARB02	R/I (BASEEFA)	24	0.3		N/A	7.2	25
C-ARB03	R/I (PTB)	24	0.3		N/A	7.2	25
C-AR000	Relay	24	0.06		N/A	1.5	5

Continued on next page

B.2 Basic Systems Power Requirements, Continued

Specification,
continued

Table B-3 Basic System Power Requirements—Auxiliaries, continued

Basic and Multifunction Controllers		Output	DC Input Voltage	DC Amps	DC Inrush	Line Power Watts	Dissipated BTUs/Hr
Model #	Description						
Analog Displays							
C-LD100	Single Indicator	N/A	24	44	N/A	1.1	3.8
C-LD200	Dual Indicator	N/A	24	48	N/A	1.2	4.1
C-LML00	Manual Loader	4-20ma	24	70	N/A	1.7	5.8
C-LMD00	w/Indicator	4-20ma	24	74	N/A	1.8	6.1
C-LAS00	Auto	4-20ma	24	58	N/A	1.4	4.8
C-LA200	Auto Manual	4-20ma	24	74	N/A	1.8	6.1
C-LA201	w/Standby Man. Cap.	4-20ma	24	109	N/A	2.7	9.2
C-LC100	Manual	4-20ma	24	63	N/A	1.6	5.5
C-LC101	w/Standby Man. Cap.	4-20ma	24	98	N/A	2.4	8.2
C-LC200	Dual Manual	4-20ma	24	117	N/A	2.9	9.9
C-LC201	w/Standby Man. Cap.	4-20ma	24	152	N/A	3.7	12.6
C-LSM01	Single Loop Standby	4-20ma	24	20	N/A	0.5	1.7
C-LSM04	4-Loop Standby	4-20ma	24	200	N/A	4.8	16.4
Hiway Interface							
C-HCB01	Basic Controller Interface (Dual) Cards		24	750	N/A	18	61.5
C-HCB20	Extended Controller Interface (Dual) Cards		24	500	N/A	12	41.0
J-HCB52	Multifunction Controller Interface (Dual) Cards		24	840	N/A	20.2	69.0
C-HC100	General Purpose Interface		24	2000	8	48	163.9
C-HPE00	Hiway Preferred Access Expander		24	625	4	15	51.2
C-HTD00	Hiway Traffic Director		24	2000	5	48	163.9

Continued on next page

B.2 Basic Systems Power Requirements, Continued

Specification,
continued

Table B-3 Basic System Power Requirements—Auxiliaries, continued

Basic and Multifunction Controller		DC Input Volts	DC Amps	MAX DC Amps	DC Inrush Amps	Line Power Watts	Dissipated BTUs/Hr
Model #	Description						
C-AF000	Auxiliary File	24	N/A		N/A	0	0
C-AC100	Single Unit Case	24	N/A		N/A	0	0
C-AA100	Alarm Single	24	0.1		N/A	2.4	8
C-AA101	Alarm Single w/ Relay	24	0.24		N/A	5.8	20
C-AA200	Alarm Dual	24	0.12		N/A	2.9	10
C-AA201	Alarm Dual w/ Relay	24	0.26		N/A	6.3	22
C-AZL01	Integrator Linear	24	0.15		N/A	3.6	12
C-AZS01	Integrator Square Root	24	0.15		N/A	3.6	12
C-APM00	Adder/Subtractor	24	0.07		N/A	1.7	6
C-AMH00	MV/I (10-50 mV)	24	0.25		N/A	6	20
C-AML01	MV/I (2-100 mV) FM & CSA	24	0.25		N/A	6	20
C-AML02	MV/I (2-100 mV) BASEEFA	24	0.25		N/A	6	20
C-AML03	MV/I (2-100 mV) PTB	24	0.25		N/A	6	20
C-AXD00	Multiplier/Divider	24	0.11		N/A	2.7	9
C-ASD00	Signal Isolator	24	0.36		N/A	8.7	30
C-ASL00	Signal Limiter	24	0.2		N/A	4.8	16
C-AEX01	Square Root Ext.	24	0.1		N/A	2.4	8
C-ASC00	Signal Selector/Scale&Bias	24	0.18		N/A	4.4	15
C-ARB01	R/I (FM and CSA)	24	0.3		N/A	7.2	25
C-ARB02	R/I (BASEEFA)	24	0.3		N/A	7.2	25
C-ARB03	R/I (PTB)	24	0.3		N/A	7.2	25
C-AR000	Relay	24	0.06		N/A	1.5	5

Continued on next page

B.2 Basic Systems Power Requirements, Continued

Specification,
continued

Table B-4 Basic System Power Requirements—PIU I/O Modules

PIU I/O Modules with 100% active Points		24 VDC Supply	Module Watts	Dissipated BTUs/Hr
Model #	Description	Milliamps		
TCB50	Pnt CardFile Term Pnl		2.5	.0
XID21	Digital Input Card	90	0.32	7.5
XID21	Digital Input Card	90	0.32	7.5
XID31	Digital Input Card	90	0.32	7.5
XID41	Digital Input Card	90	0.49	7.5
XID51	Digital Input Card	140	0.53	11.6
XID61	Digital Input Card		0.78	.0
XID62	Digital Input Card		0.84	.0
XIP11	Pulse Input Card	160	3.4	13.0
XIP21	Pulse Input Card	160	0.15	13.0
XIP31	Pulse Input Card		0.53	.0
XIP41	Pulse Input Card		0.5(3)	.0
XOD31	Digital Output Card	410	0.5	33.5
XOD41	Digital Output Card	180	1.3(3)	14.7
XIA12	Analog Input Card	30	0.14	2.5
XIA22	Analog Input Card	30	0.32	2.5
XIA32	Analog Input Card	230	0.49	18.8
XIA42	Analog Input Card	30	0.53	2.5
XIA81	Analog Input Card		0.78	.0
XIA91	Analog Input Card		0.84	.0
XOA21	Analog Output Card	270	3.4	22.2
XOA31	Analog Output Card		0.15	.0
LEL01	Digital Inputs Display	240	0.53	19.7
LEL11	Momentary Switch	240	0.5(3)	19.7
LEL21	Alt. Switch	240	0.5	19.7
LEM01	Digital Output Display	340	1.3(3)	27.9
LEM21	Digital Output Display	340	0.14	27.9

Continued on next page

B.2 Basic Systems Power Requirements, Continued

Specification,
continued

Table B-5 Basic System Power Requirements—PIU

Basic and Multifunction Controllers		FREQ.	AC Input Volts	AC Amps	AC Inrush	Line Power	Dissipated BTUs/Hr
Model #	Description	Hz	Volts	mA	A	Watts	BTUs/hr
Process Interface Units							
PCRH6X	HL PIU	60	105 to 120	7.1 Max.	100	750	2,561
PCRH5X	HL PIU	50	220 to 240	3.7 Max.	50	750	2,561
PCRL6X	LL PIU	60	105 to 120	4.0 Max.	100	450	1,536
PCRL5X	LL PIU	50	120 to 240	2.0 Max.	50	450	1,536
PCRS6X	LE PIU	60	105 to 120	3.3 Max.	100	350	1,195
PCRS5X	LE PIU	50	220 to 240	1.7 Max.	50	350	1,195
PCRC6X	HL & LL PIU	60	105 to 120	6.0 Max.	100	500	1,707
PCRC5X	HL & LL PIU	50	120 to 240	3.0 Max.	50	500	1,707
FANS without plate							
C-EF050		50 or 60	100	1	1.6	61	208.3
C-EF051		50	220 or 240	0.44	0.69	61	208.3
C-EF060		60	115	0.87	1.4	61	208.3
FANS with plate							
C-EF151		50	220	0.44	0.69	61	208.3
C-EF152		50	220	0.44	0.69	61	208.3
C-EF160		60	115 or 240	0.87	1.4	61	208.3
C-EF162		60	115	0.87	1.4	61	208.3
C-EF251		50	220	0.44	0.69	61	208.3
C-EF252		50	220	0.44	0.69	61	208.3
C-EF260		60	115	0.87	1.4	61	208.3
C-EF262		60	115	0.87	1.4	61	208.3
Multifunction Control System							
DSC11	LBOS	60	115	1.3	60.0	101.4	346.2
DSC21	LBOS	50	220	0.7	30.0	104.7	357.5
DSP51	Line Printer	60	115	0.87	12.6	100.0	341.4
DSP52	Line Printer	50	220	0.45	6.6	99.0	338.0

Continued on next page

B.2 Basic Systems Power Requirements, Continued

Specification,
continued

Table B-5 Basic System Power Requirements—PIU, continued

Basic and Multifunction Controllers		AC Input Volts	Amps	AC Inrush	Line Power	Dissipated BTUs/Hr
Model #	Description	Volts	mA	A	Watts	BTUs/hr
Data Hiway Port						
C-HL200	DHP	24	5	N/A	120	409.7
PIU Card Files						
PCRH52/62	High Level PIU CCFA	24 (Nom) 30(Max)	4 Max @ 30Vdc	N/A	120	409.7
*2	High Level PIU PCFA	24 (Nom) 30(Max)	2.4 Max @ 30Vdc (1)	N/A	75	256.1
RCRL52/62	Low Level PIU CCFA	24 (Nom) 30(Max)	4 Max @ 30Vdc	N/A	120	409.7
*2	Low Level PIU PCFA	24 (Nom) 30(Max)	1 Max @ 30Vdc	N/A	30	102.4
PCRS52/62	Low Energy PIU CCFA w/max. # MUX boxes	24 (Nom) 30(Max)	4 Max @ 30Vdc	N/A	120	409.7
Recorders						
C-RP1XX	Recorder 1- pen	24 Vdc	0.24	N/A	5.8	19.8
C-RP1XX	Recorder 1- pen	24 Vac	0.2	N/A	5	17.1
C-RP2XX	Recorder 2- pen	24 Vdc	0.4	N/A	9.6	32.8
C-RP2XX	Recorder 2- pen	24 Vac	0.2	N/A	5	17.1
C-RP3XX	Recorder 3- pen	24 Vdc	0.57	N/A	13.7	46.8
C-RP3XX	Recorder 3- pen	24 Vac	0.2	N/A	5	17.1

B.3 Basic Power Supplies

Specification

Table B-6 Basic Power Supply Specifications

Basic & Multifunction Controller		DC Volts	Max DC Amps	AC RMS Amps	RMS Input Volts	Input Voltage	Line Freq.	AC Inrush Amps	Output Power Watts	Line Power Watts	Crest Factor	Power Factor	AC Peak Amps	Dissipated BTUs/Hr
Model #	Mfg	vdc	amps	amps	vac	vac	Hz	amps	watts	watts	ratio	ratio	amps	BTUs/hr
C-SSC-61 30731565-100	SOLA	25	7	2.35	120.3	102/ 132	60	40	175	228	1.4	0.806	3.5	180.95
	North Elect.	24	7		115		60	40						400.1
C-SSC-50 30731565-005	North Elect.	24	7		220/ 240		50	55						400.1
C-SSC-51 30731565-003	SOLA		7		105/ 120		50	20.8						383
	North Elect.		7		105/ 120		50	80						410.4
C-STC-61 30731565-002	SOLA	25	20	6.07	115.2	102/ 132	60	75	500	621	1.4	0.888	8.1	413.11
	North Elect.		20		115		60	120						1145.5
C-STC-50 30731565-006	SOLA		20		220/ 240		50	60						1111.3
	North Elect.		20		220/ 240		50	110						1145.5
C-STC-51 30731565-006	SOLA		20		105/ 120	90/ 120	50	60						1111.3
	North Elect.		20		105/ 120	105/ 135	50	190						1145.5
Battery BackUp	Relay													
C-SBU11	Mercury		40			105/ 115								707.8
C-SBU01	Dis- placemnt		40			220/ 240								752.3
C-SBU12	Electro- Mech.		40			105/ 115								707.8
C-SDC51 Chart Drv Pwr.						24	50							47.9
C-SDC61 Chart Drv Pwr.						24	60							47.9

B.4 Advanced Multifunction Controller (A-MC) Modules

Specification

Table B-7 A-MC Module Power Consumption

Advanced Multifunction Controller Modules		Power Consumption (ma) 24 Vdc	In-Rush Current (A) 24 Vdc
Model # *	Description		
J-MSC10	Control Module (MCM)	235	5
J-MHM10	Hiway Interface Module (HIM)	370	–
J-HCX00	Hiway Cable Interface (HCIM)	130	8
J-UDM00	UAC Director Module	500	5
J-HAM10/HAF10	Analog Input Module (HAIM)	150	3
J-HMM00/HMF00	High Level Analog Multiplexer Module (HMUXM)	60	3
J-AOM10/AOF10	Analog Output Module (AOM)	500 **	3
J-DIM00/DIF00	Digital Input Module (DIM)	65	3
J-DIM10/DIF10	Digital Input Module (48 V)	75	3
J-DOM00/DOF00	Digital Output Module (DOM/DC) 16 points	65	3
J-DOM10/DOF10	Digital Output Module	100	3
J-DOM20/DOF20	DOM Relay	280	3
J-PIM00/PIF00	Pulse Input Module	150	3
J-STM00/STF00	Smart Transmitter I/F Module	130	3

* I/O Module Model J-XXMXX is for the remote terminal panel and J-XXFXX is provided with the front terminal block.

** This value also includes the 20 mA output current for each of the 16 output points.

Appendix C – Site Grounding Examples

C.1 Overview

Section contents These are the topics covered in this section:

	Topic	See Page
C.1	Overview	173
C.2	Console Located in Operator Area	174
C.3	Grounding Intrinsically	177
C.4	Batch Control System Grounding	178
C.5	Batch Control System's 56-Conductor Cable Shield Grounding	179
C.6	Hiway Coupler Modules User as Energy Barrier	180
C.7	Typical Power Distribution for PIU	182

C.2 Console Located in Operator Area

Example A

The first example has consoles in an operator area (as shown in Figure C-1), cabinets located in an I/O area (as shown in Figure C-2), and PIUs located in a remote area (as shown in Figure C-3).

The only connection between separate sections of the system is the Data Hiway.

Note 1 in Figure C-1:

The connection on TB2 denotes a green wire from ac power distribution panel.

Figure C-1 Operator Console Located in Operator Area

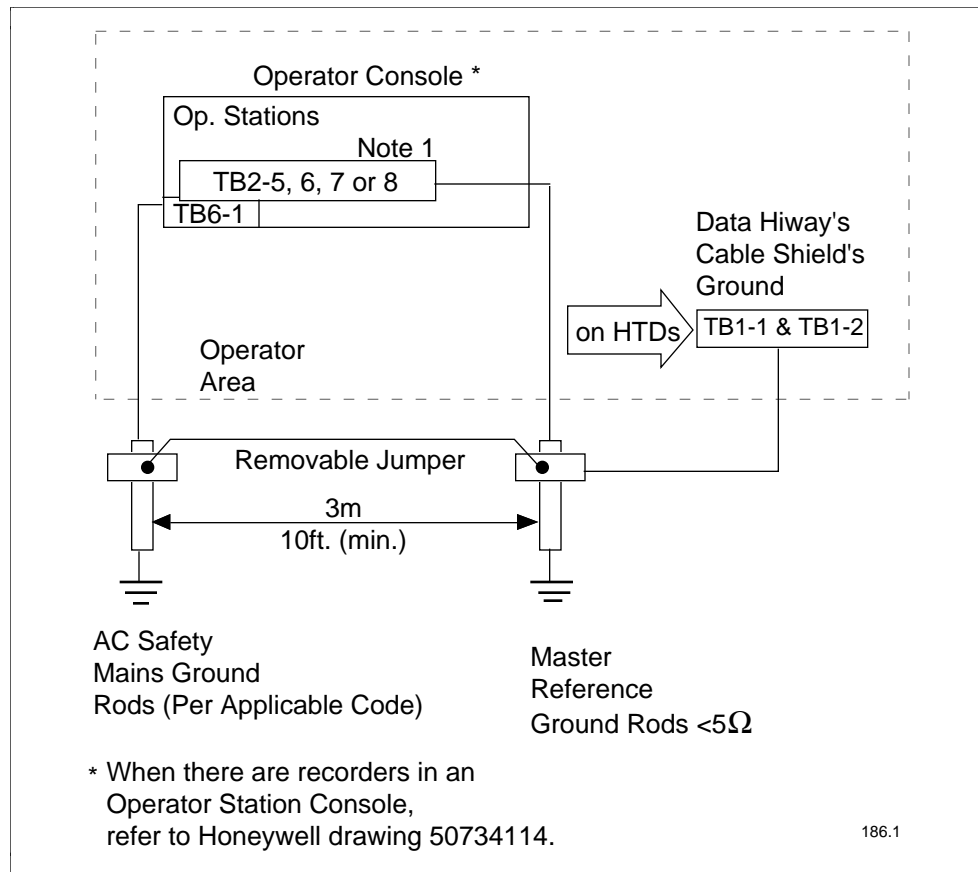

Continued on next page

C.2 Console Located in Operator Area, Continued

Illustration

Figure C-2 Cabinet Located in I/O Area

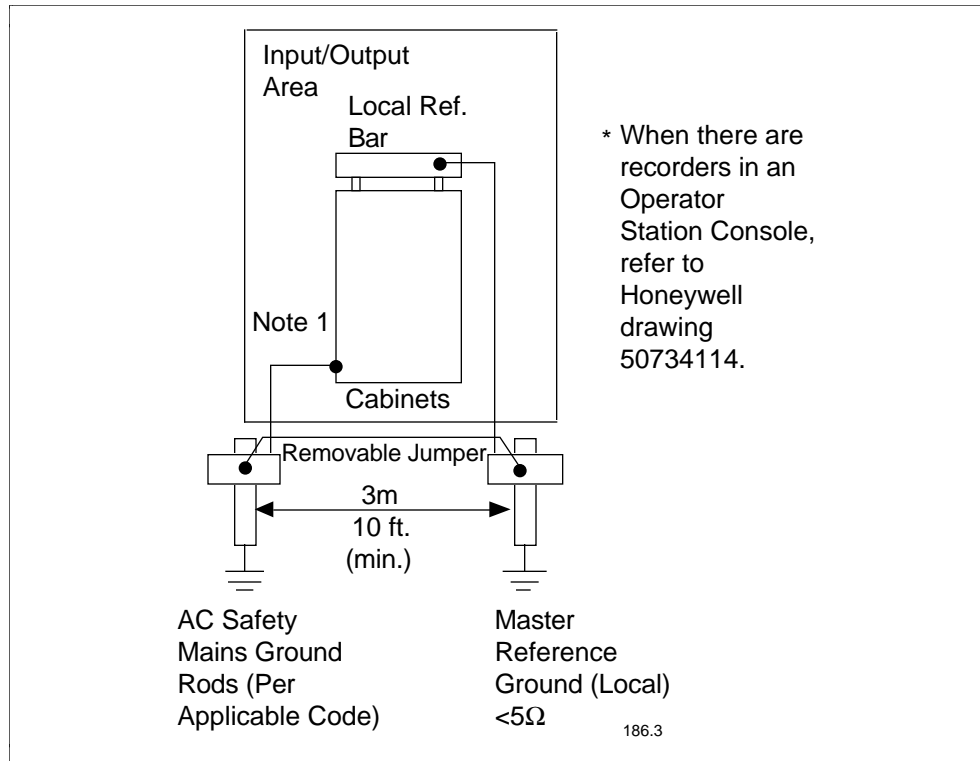

Continued on next page

C.2 Console Located in Operator Area, Continued

Illustration

Figure C-3 PIUs Located in a Remote Area

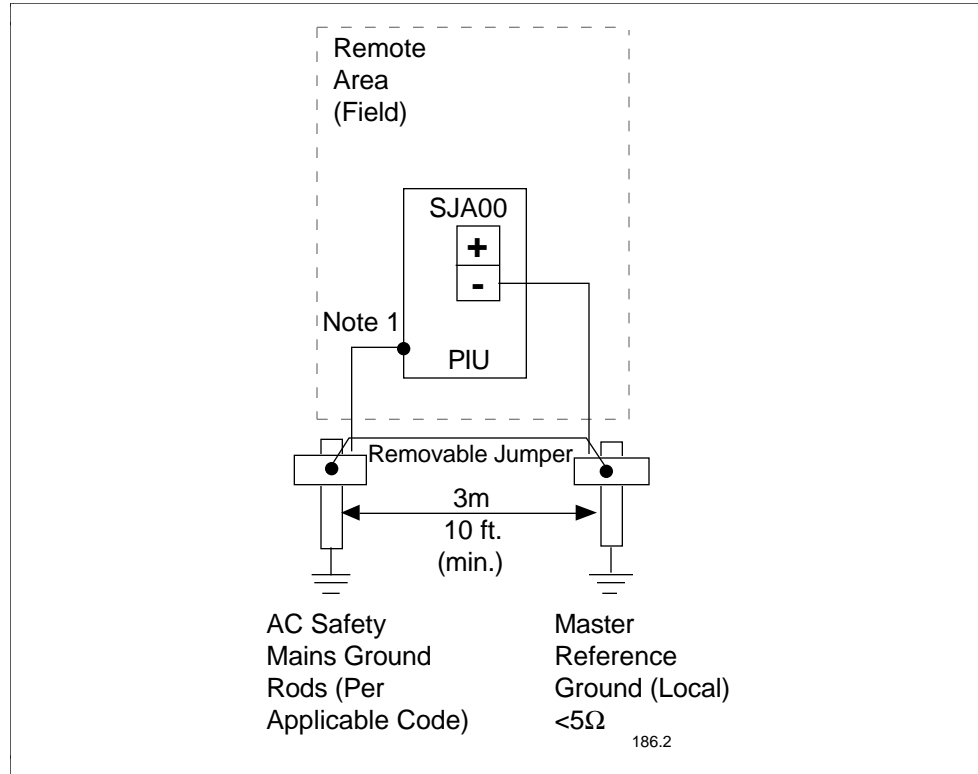

C.3 Grounding Intrinsically Safe Systems

Example B

Each barrier-ground bar must be tied back to Master Reference Ground in the general purpose area. When more than one barrier-ground is involved, a 2.22 mm (No.12 AWG), or heavier, wire is required between each barrier panel and ground. An alternate method is install a common ground reference bar in the cabinet and run separated, redundant wires of No. 6 AWG, or larger, to the Master Reference Ground. Refer to Example D for the alternate method of ground barriers.

Illustration

Figure C-4 Grounding Intrinsically Safe Systems

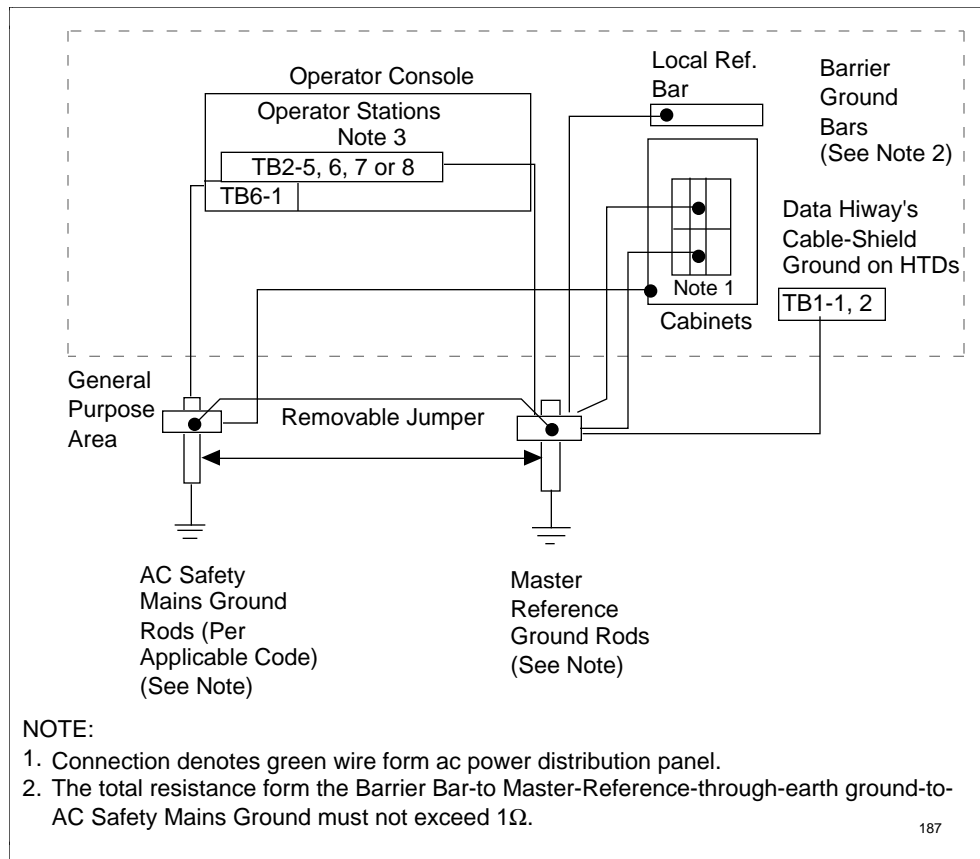

C.4 Batch Control System Grounding

Example C

Local Batch Operator Stations (LBOS) are connected to the controller cabinets by C-Link cables and adapter boxes. The logic common (LC) is connected to Master Reference Ground (MRG) at the back of the LBOS (TB3) C-Link. Cable shields are connected to MRG through only the right-hand COM terminal, from one C-Link adapter box in the daisy-chain hookup. The system must not be grounded at any other point. AC safety grounds are handled by connecting the green (or green with yellow tracer) in the circuit breaker box or plug in receptacle back to the ac Safety Mains ground system. Lightning grounds are according to Section 5, Figure 5-6.

Illustration

Figure C-5 Batch Control System Grounding

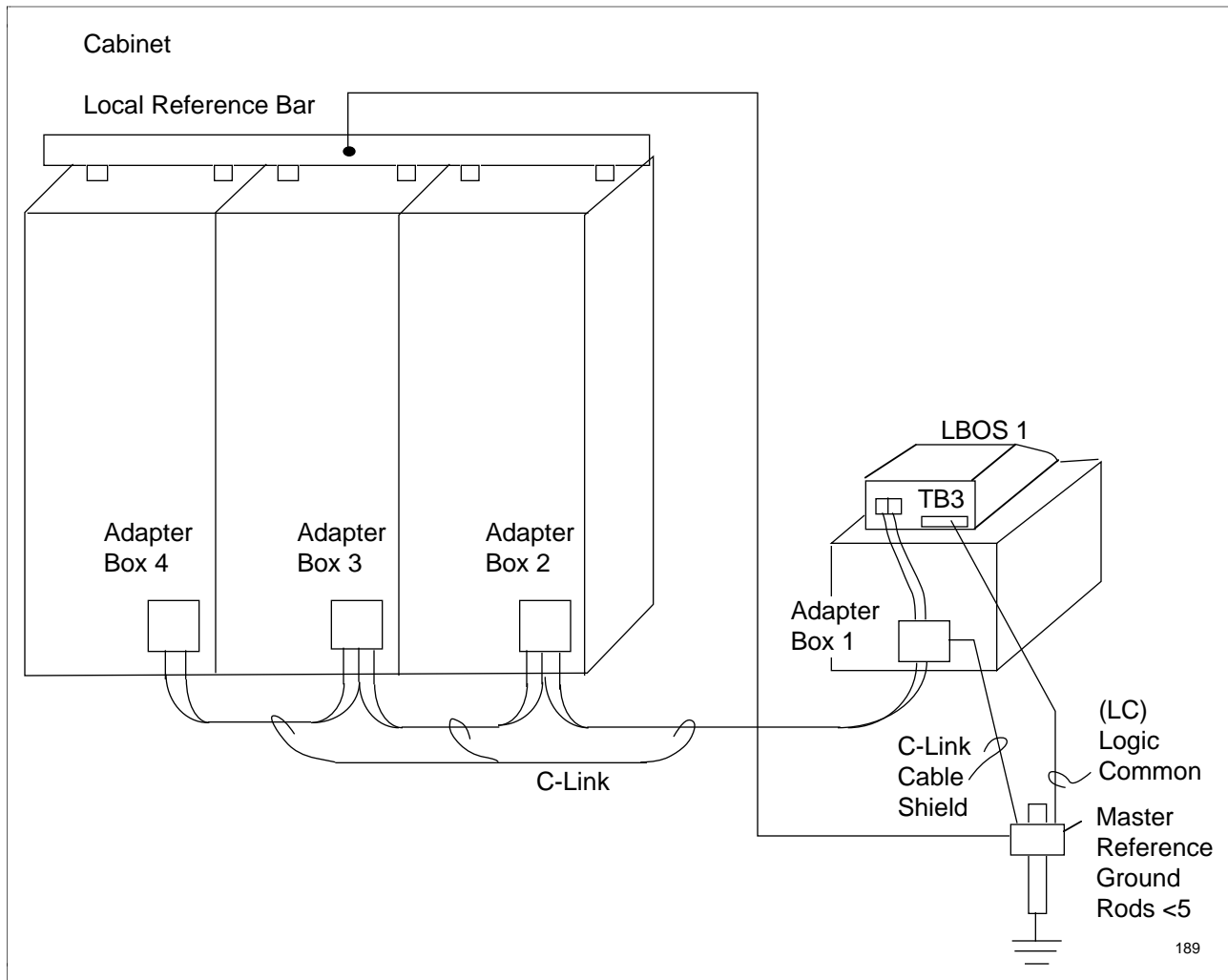

C.5 Batch Control System's 56-Conductor Cable Shield Grounding

Example D

56-conductor cable shields are to be connected to ground screws provided on TB50, TPF20, TPF30, TPF40, JCD00, and JCD10 terminal panels. A ground wire is then run from each panel to the PSC bus bar that connects to Master Reference Ground (MRG). See Figure C-6.

Figure C-6 Batch Control System's 56-Conductor Cable Shield Grounding

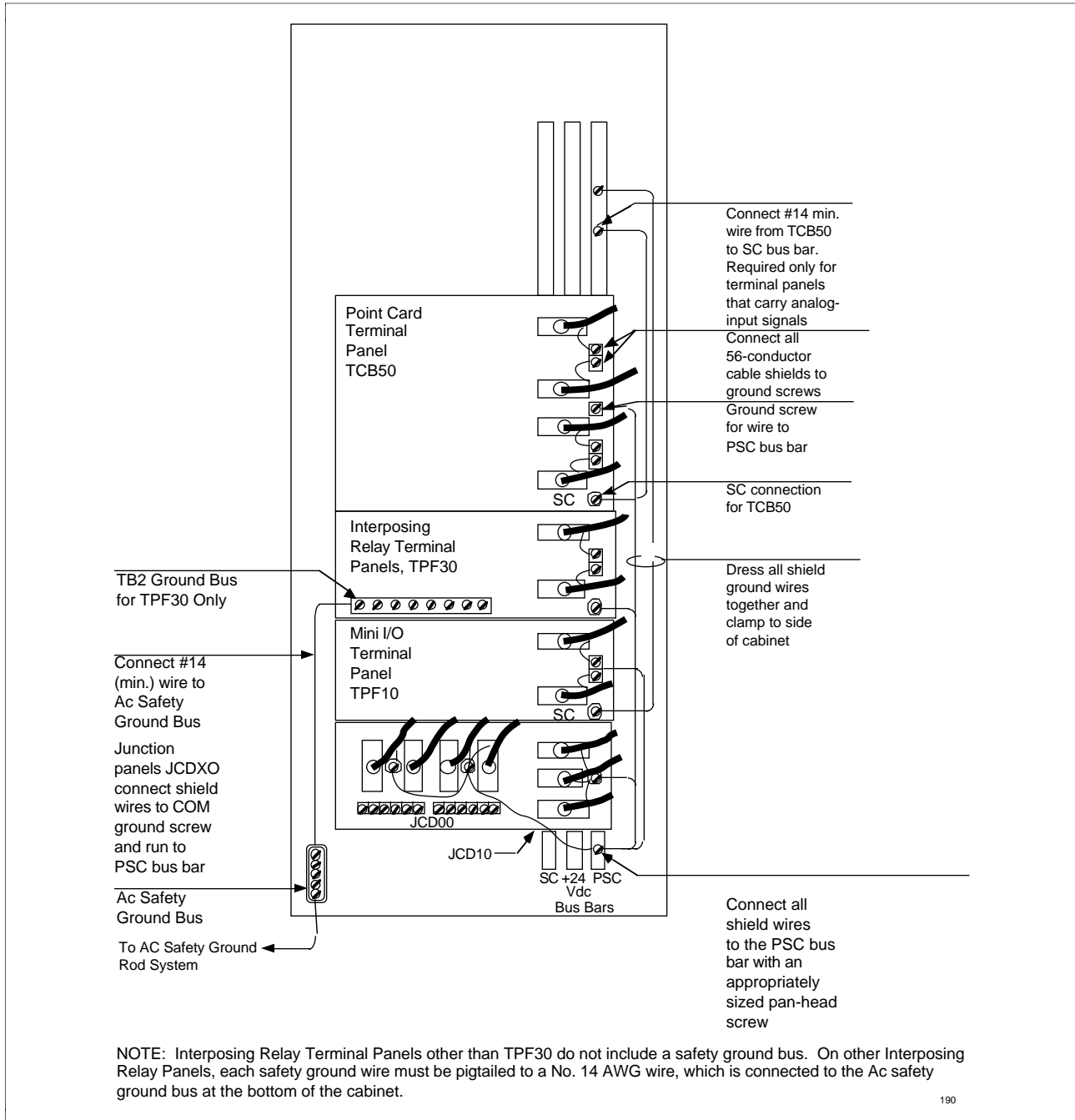

C.6 Hiway Coupler Modules Used as Energy Barrier

Example E

Hiway Coupler Modules can be used as an energy barrier using a long fiber optic link. For mounting, cabling, and interconnections, see HO-09-03.

Illustration

Figure C-7 HCM Used as Energy Barrier with a Long Fiber Optic Link

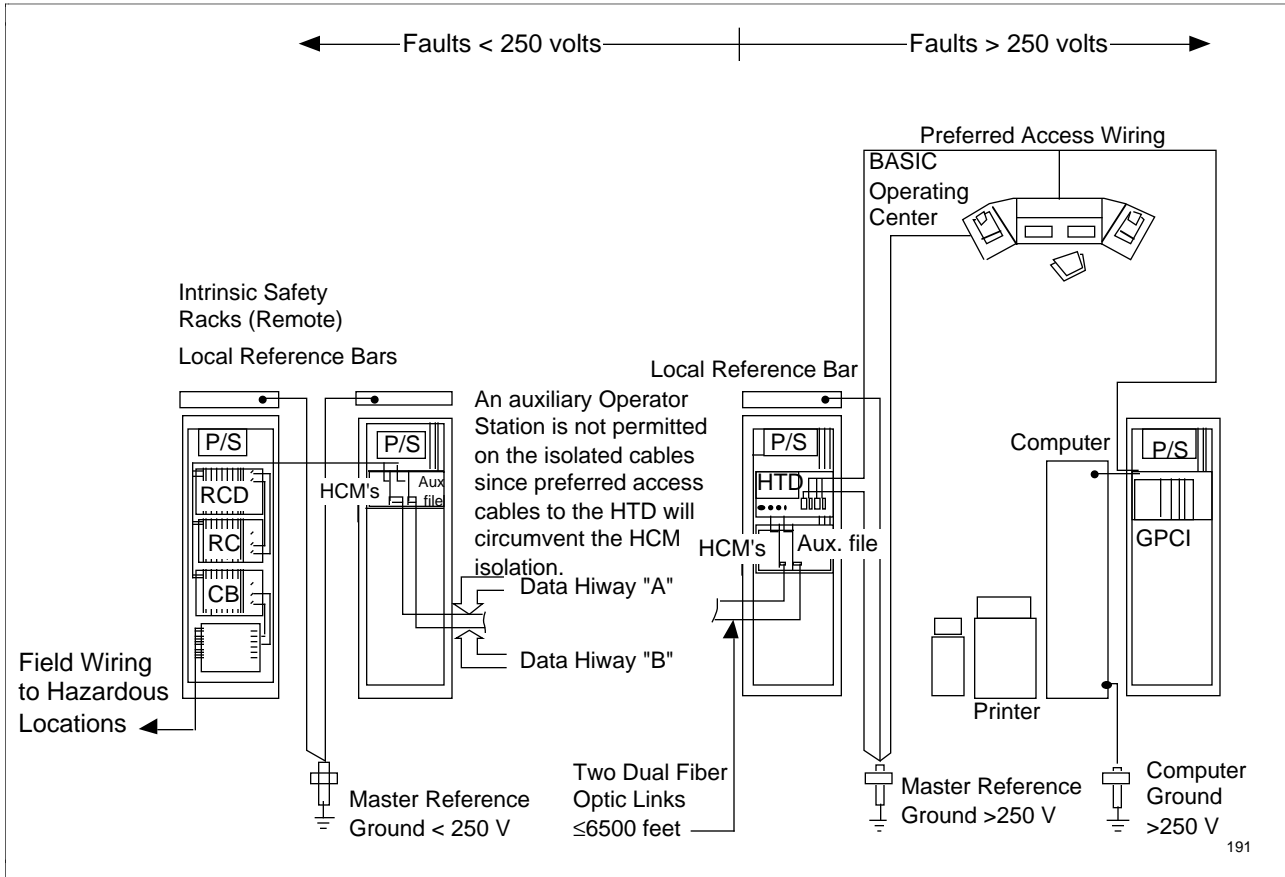

Continued on next page

C.6 Hiway Coupler Modules Used as Energy Barrier, Continued

Example F

Hiway Coupler Modules can be used as an energy barrier using a short fiber optic link. For mounting, cabling, and interconnections, see HO-09-03.

Illustration

Figure C-8 HCM Used as Energy Barrier with a Short Fiber Optic Link

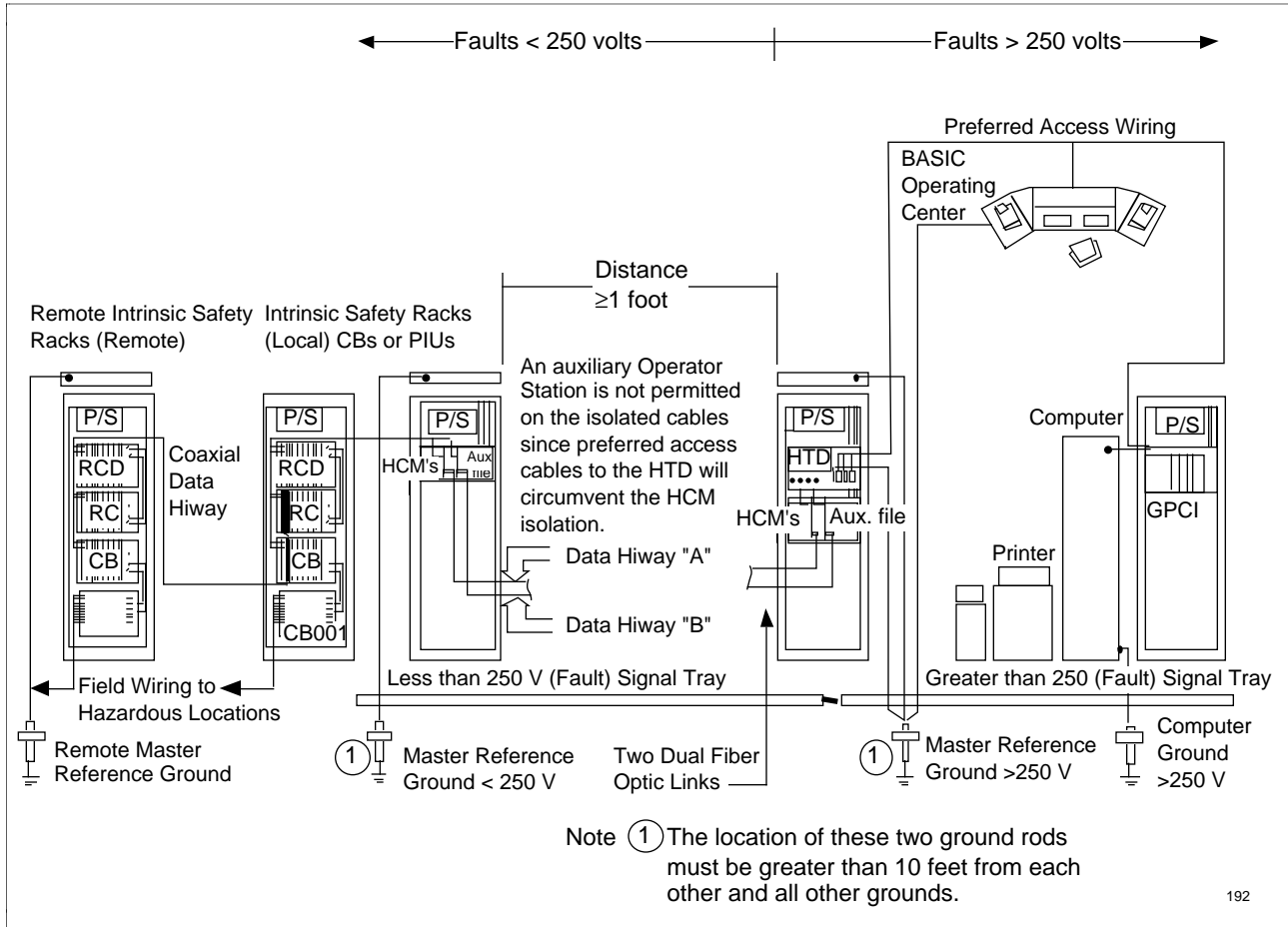

C.7 Typical Power Distribution for PIU

Example G

Figure C-9 Typical Power Distribution Schematic for PIU

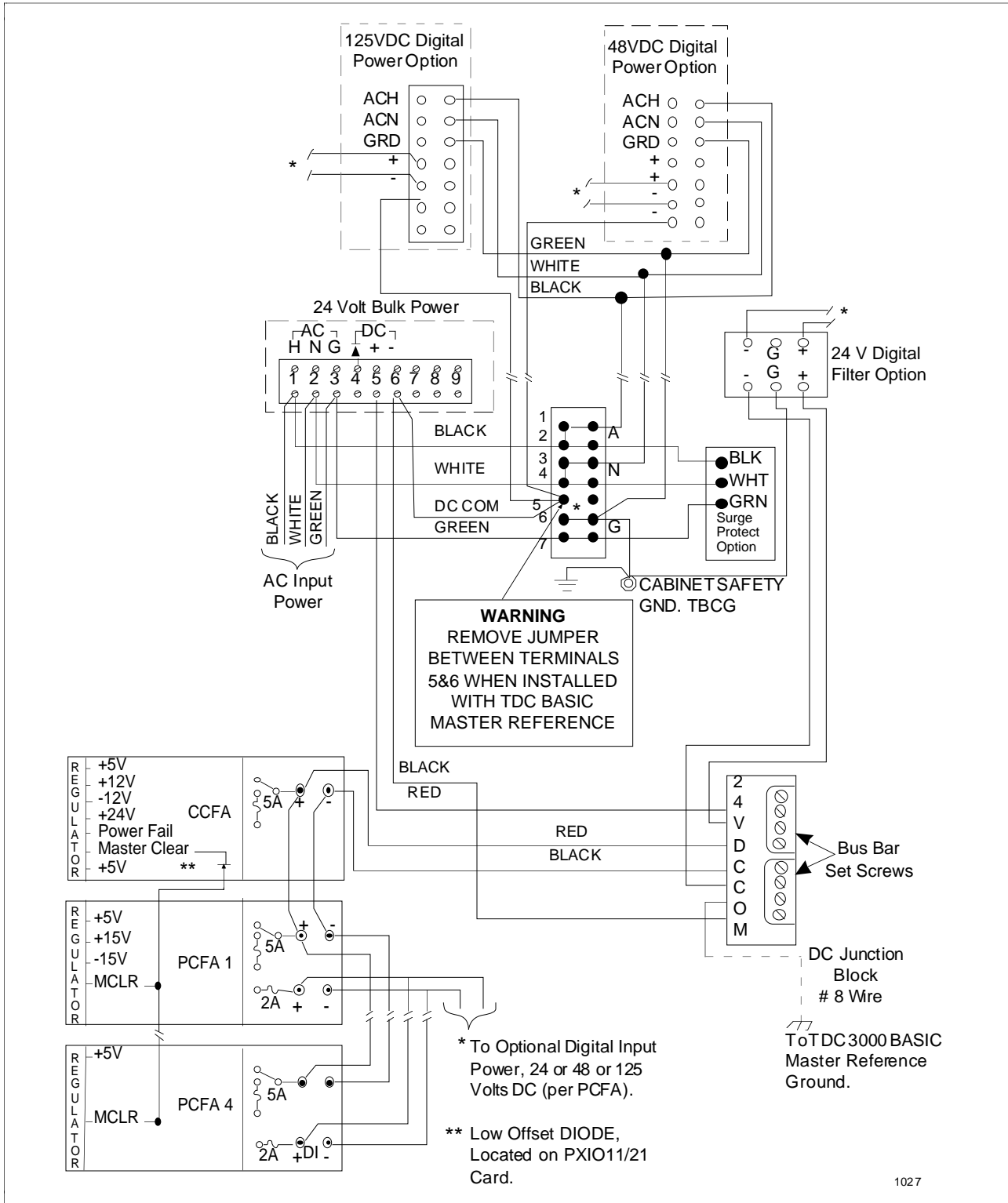

1027

Index

A

A-MC Module Power Consumption *171*
AC Power *41*
AC Power Source *41, 42*
AC Safety Ground System (mains ground) *102*
AC Safety Ground System (Mains) Ground *107*
AC Wiring to LBOS Console *48*
Advanced Multifunction Controller (A-MC) Modules
171
Air Conditioning *20*
Air Filtration *20*
Air velocity *23, 25*
Alternate Zener Barrier Ground System *132*
angle base frames *15*
Approved Data Hiway Cable *77*
Auxiliary devices ground *129*

B

Bamboo Hiway Cable (BHC) Connections *81*
Barrier Box *155*
Barrier Panel C-TBU10 Ground *130*
Barrier Panel Wiring *97*
Base Cabinet (Operator Station) *12*
Base Cabinet with Table Top *14*
Base Power *41*
Basic cabinet *33*
BASIC Cabinet Cable Routing *143*
BASIC Cabinet Wire Routing *143*
BASIC operating center arrangement *10*
BASIC Operator Area Design *16*
BASIC Operator Station (BOS) *44*
Basic Operator Station DC Ground *114*
Basic Operator Station Safety Ground *109*
Basic Operator Station with Remote AC Panel *45*
Basic Power Supplies *170*
Basic Power Supply Specifications *170*
BASIC System *1*
BASIC System Layout Template *1, 2, 3, 4, 5, 6*
Basic System Layout Templates *147*
Basic System Power Requirements—Auxiliaries *164*
Basic System Power Requirements—DC Power *162*
Basic System Power Requirements—Operator Interface
160
Basic System Power Requirements—PIU I/O Modules
167
Batch Control System Grounding *178*
Batch Control System Power Distribution *57*
Batch Control System's 56-Conductor Cable Shield
Grounding *179*
Battery Backup *53*
Bonding *73*
Branch-Length and Polled Device-Addressing
Constraints *86*

C

C-Link Cabinet Cable Assembly *65*
C-Link Communications Cables *64*
C-Link Grounds *116*
C-Link Shield Grounding *116*
Cabinet Descriptions *33*
Cabinet Dimensions *142*
Cabinet Located in I/O Area *175*
Cabinet Placement Considerations *36*
Cabinet Safety Ground *110*
Cabinet with Files, Power Supply, and Terminal
Panels *34*
Cable
 25-Conductor *62*
 50-Conductor *61*
 56-Conductor *63*
Cable Installation *78*
Cabling Considerations *32*
CC-Link Communications Cables *64*
Centralized I/O advantages *5*
checkout *27*
Coax cable *79*
Codes and References *103*
color-coded coaxial cables *76*
Communications *19*
Complexed Cabinets *34*
Conduit and Cable Trays *53*
Connection between files and terminal panel *119*
Console base *144*
Console Base and Wedge Units *144*
Console Development for Layout *145*
Console Located in Operator Area *174, 175*
Console with Integral Breaker Panel *46*
Consoles and Cabinets *141*
Contaminate classification *22*
Contaminates *21*
Control-Room Lighting *19*
Controller File to Terminal Panel Voltage Drop *58*
Copper Reactivity *22*
Corrosive Compounds *24*
Current Flow between File Systems and Terminals
119

Index

D

Data Entry Panel Case Ground *111*
Data Hiway
 redundant cables that *2*
Data Hiway Address Assignments *84*
Data Hiway Address Capacity/Assignments *83*
Data Hiway Branch with Two Fiber Optic Links *89*
Data Hiway Cable Installation *79*
Data Hiway Cable System *76*
Data Hiway Connected Devices (Boxes) *76*
Data Hiway Electrical Loading *83*
Data Hiway Noise Shielding *85*
Data Hiway Shields Ground *124*
DC Power and Bus Bar System *54*
DC Power Distribution *54*
DC Power Distribution to Input/Out Cabinets *56*
Description *69, 74, 77, 78, 93*
Digital Input and Output Signal Cable Types *75*
Dimension and Specifications for Remote Multiplexer
 Box *154, 155*
Disruption *6*
Distributed I/O advantages *5*

E

electrical interference *105*
Electromagnetic Interference *6, 19*
Emergency Lighting *20*
environmental classifications *22*
Environmental Considerations *6*
equipment layout *7*
Expanded Operating Center *11*
Electric Power *6*

F

Electric Power *6*
Factory Mutual (FM) Specifications *98*
Fiber optic cable *82*
Fiber Optic Link Grounds *135*
Field Device Grounds *137*
Field input/output wiring *98*
Field wire connections *67*
Fire Precautions *19*
Floors *19*
FM's Maximum Allowable Values for Inductance and
 Capacitance *99*

G

Gas flow *24*
Gas-flow concentrations *23*
General operating practices *26*
General operating procedures *23*
GRANT COM *123*
Ground Loops *105*
Ground rod *103*
Ground Sites *103*
Grounding Considerations *101*
Grounding Intrinsically *177*
Grounding Intrinsically Safe Systems *177*
Grounding Summary *138*
Guidelines
 AC power *41*
 Branch Length *86*
 Cabinet Placement *36*
 Cabling considerations *32*
 Data Hiway shields ground *124*
 Fiber optic link grounds *135*
 Field device ground *137*
 Ground sites *103*
 Installing underground conduit *93*
 Isolation of ground sites *104*
 Methods of signal protection *70*
 Multiconductor cable routing *66*
 Planning Input/Output Areas *30*
 Polled device addressing constraints *86*
 Power Distribution *43*
 Prevention of impedance coupling *71*
 Process Plant Environmental *25*
 Separation of controller files and terminal panel
 119
 Signal cable connection *74*
 Signal cable types *75*
 Signal wiring *67*

H

HCM at Either End of a Fiber Optic Link *82*
HCM Used as Energy Barrier *180, 181*
High Level Analog Signal Cable Types *75*
High Level and Low Level PIU Ground *133*
High Level and Low Level PIU Ground Connections
 133
Hiway Coupler Module (HCM) *82*
Hiway Coupler Modules Used as Energy Barrier *180,*
 181
Hiway Gateway Interface Card Showing TB1 *126*
Hiway Gateway Wiring *125*
Hiway Traffic Director Ground *121*
Honeywell Customer Information Drawings *3*
HTD at the End of a Branch *80*
HTD Between Ends of a Branch *80*
HTD Power and Ground *122*

Index

I, J

- impedance Coupling 71
- Input/Output Area 1
- Input/Output Areas 29
- Input/Output Cabinets 50
- Installation 27
- Installing Underground Conduit 93
- Instrument Loop with Single Ground 105
- Instrument Loop with Two Grounds 106
- Interposing Relay Terminal Panel Grounds 109
- Intrinsic Safety Grounds 129
- Intrinsically Safe Wiring 95
- Intrinsically Safe Wiring for Auxiliary Files 96
- Introduction 1
- IR drop 58
- Isolation 104
- Operating Center 3
- Operating Center Console 144
- Operator Area 1
- Operator Console Located in Operator Area 174
- Operator Console with Three Operator Stations 11
- Overview of Preferred Access Cabling 127

L

- LBOS Ground 115
- LBOS Safety Ground and Logic Common Grounds 115
- LCN Style Console 146
- LCNE 82
- LCNFL 82
- LEPIU Barrier Box PISBIX Ground Connector 131
- LEPIU Cabling 156
- LEPIU CFA Ground 134
- LEPIU Layout Information 156
- Lightning Ground (General Purpose Area) 113
- Lightning Ground System 102
- Lightning Grounds 112
- Local Batch Operator Station (LBOS) 47
- Local Batch Operator Station—AC Safety Ground 109
- Local Control Network Extender 82
- Local Control Network Fiberlink 82
- Local Reference Bar 118
- Low Energy CFA Ground 134
- Low Level Analog Signal Cable Types 74

M

- Marshalling Panel Grounds 136
- Marshalling Systems 59
- Master Reference (signal common) Ground 102
- Maximum Safe Pull Forces for Coax Cable 82
- Media Storage 18
- Methods of Signal Protection 70
- Multiconductor Cable Routing 66

- Multifunction Control Design 36
- Multiple Units 33
- Multiunit Cabinet DC Ground 118

N

- New Style Console 146
- New Style Consoles 153
- Noise suppression 70

O

- Operating Center 3
- Operating Center Console 144
- Operator Area 1
- Operator Console Located in Operator Area 174
- Operator Console with Three Operator Stations 11
- Overview of Preferred Access Cabling 127

P, Q

- PIUs Located in a Remote Area 176
- Planning Input/Output Areas 30
- Planning the Operator Area 9
- Polling Address Restrictions 91
- Potential Noise Sources 69
- Power (dB) Losses in the Fiber Optic Link 90
- Power Distribution 43
- Power Requirements for BASIC Equipment 159
- Power source 41
- Power Source with a Dedicated Transformer 108
- Power supply 134
- Power supply ground 133
- Preferred 121
- Preferred Device Terminal Wiring 123
- Preferred Device Wiring Shield Ground 123
- Preferred Devices 85
- Preferred-Device Wiring 93
- Preparation 7
- Process Plant Environment 21
- Process Plant Environmental Guidelines 24
- Professional publications 27
- Purging Conduit 94
- purification system 25

Index

R

Redundant cables
 Data Hiway 2
Reference 136
Reference Documents 58, 59
References 27
Requirements 18
Relative humidity 23
Remote Multiplexer Box 154
Requirement 107, 109, 110, 111, 112, 114, 115, 116,
 117, 118
Routing of AC Power Wiring from Cabinet-Mounted
 Power Boxes, Circuit Breaker 52
Routing of AC Power Wiring from Separate Breaker
 Panel 51
Rules 125

S

Safety 19
Safety ground 133, 134
Sample Layout for Hazardous Areas 157
Screw terminals 67
Security 6
Separate Dedicated Power Circuits 120
Separated Controller Files and Terminal Panel 119,
 120
Service 6
Service Panel and Mains Ground Rods 107
Signal Cable and Connection 74
Signal cables as potential noises sources 69
Signal Grounds for Devices on the Data Hiway 124
Signal types 67
Signal Wiring 67, 68
Single Cabinet DC Ground 117
Site Development 5
Site Grounding Examples 173
Site Layout 6
Site layout parameters 6
Soundproofing 19
Specification 156
 AC Power 41
 Barrier box 155

 Basic cabinet 33
 Data Hiway address assignments 84
 Data Hiway address capacity/assignments 83
 Data Hiway electrical loading 83
 FM intrinsically safe wiring 98
Standard Cabinet—Exploded View 31
Structural Requirements 7
System Interconnections 60

T

Table top wedge 15
TDC 3000X System Showing One Branch 92
TDC 3000X System with Hiway Gateways 4
Transmission Time Losses. 87
Two Bay Operating Center 10
Types of Cabinetry 33
Typical Grounding Methods 139, 140
Typical Input/Output Area Layout 37
Typical Operator Layout 17
Typical Power Distribution for PIU 182
Typical Power Distribution Schematic for PIU 182

U,V

Uninterruptible Power System 49
Upright Cabinet Dimensions 142
Upright Cabinets 142

W, X, Y

Wedge Unit (Console) 15
Wedge units 144
Wire shield grounds 138
Wire Size 58
Wiring Concepts 95
Wiring Considerations 39
Work Flow 6
Work surface 14

Z

Zener barrier ground 129

READER COMMENTS

Honeywell's IAC Automation College welcomes your comments and suggestions to improve future editions of this and other publications.

You can communicate your thoughts to us by fax, mail, or toll-free telephone call. We would like to acknowledge your comments; please include your complete name and address.

BY FAX: Use this form; and fax to us at (602) 313-4108

BY TELEPHONE: In the U.S.A. use our toll-free number 1*800-822-7673 (available in the 48 contiguous states except Arizona; in Arizona dial 1-602-313-5558).

BY MAIL: Use this form; detach, fold, tape closed, and mail to us.

Title of Publication: **Data Hiway Planning**

Issue Date: **9/95**

Publication Number: **DH02-500**

Writer: **David Downey**

COMMENTS : _____

RECOMMENDATIONS : _____

NAME : _____ **DATE :** _____

TITLE : _____

COMPANY : _____

ADDRESS : _____

CITY : _____ **STATE :** _____ **ZIP :** _____

TELEPHONE : _____ **FAX :** _____

(If returning by mail, please tape closed; Postal regulations prohibit use of staples.)

Communications concerning technical publications should be directed to:

Automation College
Industrial Automation and Control
Honeywell Inc.
2820 West Kelton Lane
Phoenix, Arizona 85023

FOLD

FOLD

From: _____



NO POSTAGE
NECESSARY
IF MAILED
IN THE USA

BUSINESS REPLY MAIL
FIRST CLASS PERMIT NO. 4332 PHOENIX, ARIZONA

POSTAGE WILL BE PAID BY

Honeywell

Industrial Automation and Control
2820 West Kelton Lane
Phoenix, Arizona 85023

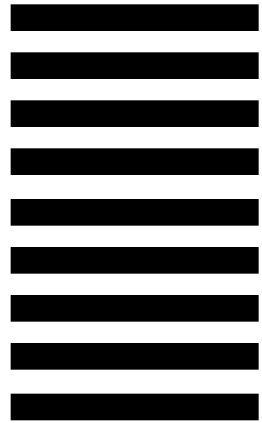

Cut Along Line

Attention: Manager, Quality

FOLD

FOLD

Additional Comments:

Honeywell

Industrial Automation and Control
Honeywell Inc.
16404 North Black Canyon Highway
Phoenix, Arizona 85023-3033

Helping You Control Your World