

Honeywell

Experion
Serial Interface Module
Implementation Guide

EP-DCX144

R300.1

5/06

Notices and Trademarks

**Copyright 2006 by Honeywell International Inc.
Release 300.1 May 5, 2006**

While this information is presented in good faith and believed to be accurate, Honeywell disclaims the implied warranties of merchantability and fitness for a particular purpose and makes no express warranties except as may be stated in its written agreement with and for its customers.

In no event is Honeywell liable to anyone for any indirect, special or consequential damages. The information and specifications in this document are subject to change without notice.

Honeywell, PlantScape, Experion, and **TotalPlant** are registered trademarks of Honeywell International Inc.

Other brand or product names are trademarks of their respective owners.

Honeywell International
Process Solutions
2500 West Union Hills
Phoenix, AZ 85027
1-800 343-0228

About This Document

Provides information about interfacing devices with your Experion system through the Serial Interface Module in a C200 Controller chassis.

Release Information

Document Name	Document ID	Release Number	Publication Date
Serial Interface Module Implementation Guide - simg	EP-DCX144	300.1	5/06

References

The following list identifies all documents that may be sources of reference for material discussed in this publication.

Document Title

Contacts

World Wide Web

The following Honeywell web sites may be of interest to Process Solutions customers.

Honeywell Organization	WWW Address (URL)
Corporate	http://www.honeywell.com
Honeywell Process Solutions	http://hpsweb.honeywell.com

About This Document
Contacts







Telephone

Contact us by telephone at the numbers listed below.







Location	Organization	Phone
United States and Canada	Honeywell IAC Solution Support Center	1-800-822-7673
Europe	Honeywell TAC-EMEA	+32-2-728-2704
Pacific	Honeywell Global TAC - Pacific	1300-300-4822 (toll free within Australia) +61-8-9362-9559 (outside Australia)
India	Honeywell Global TAC - India	+91-20-2682-2458
Korea	Honeywell Global TAC - Korea	+82-2-799-6317
People's Republic of China	Honeywell Global TAC - China	+86-10-8458-3280 ext. 361
Singapore	Honeywell Global TAC - South East Asia	+65-6580-3500
Taiwan	Honeywell Global TAC - Taiwan	+886-7-323-5900
Japan	Honeywell Global TAC - Japan	+81-3-5440-1303
Elsewhere	Call your nearest Honeywell office.	

Symbol Definitions

The following table lists those symbols used in this document to denote certain conditions.

Symbol	Definition
	ATTENTION: Identifies information that requires special consideration.
	TIP: Identifies advice or hints for the user, often in terms of performing a task.
	REFERENCE -EXTERNAL: Identifies an additional source of information outside of the bookset.
	REFERENCE - INTERNAL: Identifies an additional source of information within the bookset.
CAUTION	Indicates a situation which, if not avoided, may result in equipment or work (data) on the system being damaged or lost, or may result in the inability to properly operate the process.
	CAUTION: Indicates a potentially hazardous situation which, if not avoided, may result in minor or moderate injury. It may also be used to alert against unsafe practices. CAUTION symbol on the equipment refers the user to the product manual for additional information. The symbol appears next to required information in the manual.
	WARNING: Indicates a potentially hazardous situation, which, if not avoided, could result in serious injury or death. WARNING symbol on the equipment refers the user to the product manual for additional information. The symbol appears next to required information in the manual.

About This Document
Symbol Definitions

Symbol	Definition
	WARNING, Risk of electrical shock: Potential shock hazard where HAZARDOUS LIVE voltages greater than 30 Vrms, 42.4 Vpeak, or 60 VDC may be accessible.
	ESD HAZARD: Danger of an electro-static discharge to which equipment may be sensitive. Observe precautions for handling electrostatic sensitive devices.
	Protective Earth (PE) terminal: Provided for connection of the protective earth (green or green/yellow) supply system conductor.
	Functional earth terminal: Used for non-safety purposes such as noise immunity improvement. NOTE: This connection shall be bonded to Protective Earth at the source of supply in accordance with national local electrical code requirements.
	Earth Ground: Functional earth connection. NOTE: This connection shall be bonded to Protective Earth at the source of supply in accordance with national and local electrical code requirements.
	Chassis Ground: Identifies a connection to the chassis or frame of the equipment shall be bonded to Protective Earth at the source of supply in accordance with national and local electrical code requirements.

Contents

SERIAL INTERFACE MODULE IMPLEMENTATION	1
Overview	1
About the SIM	1
Function Block support.....	2
General Implementation Considerations	4
SIM processing characteristics.....	5
Where to look for more information	7
MODBUS FTA Installation	10
Overall Modbus interface connections	10
Mounting Modbus FTA.....	11
Wiring Modbus FTA to Power Adapter	11
Wiring Modbus FTA to Modbus Devices	14
ALLEN-BRADLEY FTA Installation	17
Overall Allen-Bradley interface connections.....	17
Mounting Allen-Bradley FTA	18
Wiring Allen-Bradley FTA to Power Adapter	19
Wiring A-B FTA to Allen-Bradley Devices	21
ALLEN-BRADLEY INTERFACE APPENDIX A	23
Array Channel Block Configuration for Allen-Bradley Interface.....	23
About Allen-Bradley interface.....	23
AUXDATA parameter configuration	23
AUXDATA[6] parameter setting details	26
DEVADDR parameter configuration.....	29
STARTINDEX and number of elements parameters configuration	29
Report by Exception requirements	30
Performance considerations.....	32
Array Channel block execution state.....	33
Write processing considerations	34
Diagnostic procedures and data configuration	34
Time-Out gate configuration.....	37
Status and error checking	37
Error messages.....	38
Special FTA to KE/KF cabling considerations	41
FTA direct to PLC-5 RS-232 Port cable considerations	42
Reference Specifications	43

Contents

MODBUS INTERFACE APPENDIX B 47

- Array Channel Block Configuration for Generic MODBUS Interface47**
 - About Generic Modbus interface 47
 - AUXDATA parameter configuration..... 47
 - STARTINDEX and number of elements parameters configuration..... 49
 - Modbus loopback diagnostic 51
 - Performance considerations..... 51
 - Array Channel block execution state 52
 - Write processing considerations..... 53
 - Status and error checking 53
 - Error messages 54
 - Special Modbus slave FTA implementation 56
 - Reference Specifications..... 58

Tables

Figures

Figure 1 Signal Path between Serial Field Device and Serial Interface Array Channel Function Block.	3
Figure 2 Modbus Serial Interface connections.....	11
Figure 3 Power Adapter to Serial Interface FTA Wiring.....	13
Figure 4 Pins common to RS-232 25-pin connector and FTA J2, DB-25 type connector.	14
Figure 5 Modbus FTA EIA-422/485 connections.....	16
Figure 6 Typical connection of Allen-Bradley devices to the SIM.....	17
Figure 7 Allen-Bradley Serial Interface connections.....	18

Serial Interface Module Implementation

Overview

About the SIM

The Serial Interface Module (SIM) is a double-width I/O module that mounts in a standard Experion chassis (or rack). It functionally serves as a communications “bridge” between the Experion Control Processor module (CPM), and a field device connected to the SIM through a Field Termination Assembly (FTA).

The SIM supports two serial ports for bi-directional communication with two FTAs through a single FTA power adapter. It does not store or maintain any field device I/O configuration or real-time data. It only transfers these data elements between the CPM and the connected field devices.

The FTA features a plug-in module that adapts I/O requirements to the specific serial interface for a given field device. The following two models are available as standard products.

- The Modbus FTA model MU-TSIM12 provides a point-to-point Modbus RTU EIA-232 (RS-232) or EIA-422/485 (RS-422/485) multi-drop communications interface.
- The Allen-Bradley (A-B) FTA model MU-TSIA12 provides a single EIA-232 (RS-232) communications interface to A-B PLC-2, PLC-3, or PLC-5 devices using the DF1 protocol.

Function Block support

The IOMODULE library in Control Builder includes an SIM IOM Function Block (SIM FB). The SIM FB (labeled TC-MUX021 or TK-MUX021) supports the configuration and assignment of a SIM to a C200 CPM. After a SIM FB is assigned to a Control Execution Environment and loaded to a CPM, communications between the SIM and the CPM are established, but not necessarily between the SIM and the field devices. To establish communications with field devices, you must configure, assign and load Serial Interface (SI) Array Channel Function Blocks through a Control Module in Control Builder.

The IOCHANNEL library in Control Builder includes the following SI Array Channel FBs.

- Numeric (SINUMARRCH)
- Flag (SIFLAGARRCH)
- Text (SITEXTARRCH)

These Function Blocks provide the application link between the control strategy and the data associated with a serial device. You establish the signal path and specify device specific parameters through the configuration forms for the SI Array Channel FBs in Control Builder.

Figure 1 provides a block diagram overview of the communications path between a serial interface field device and an SI Array Channel FB.

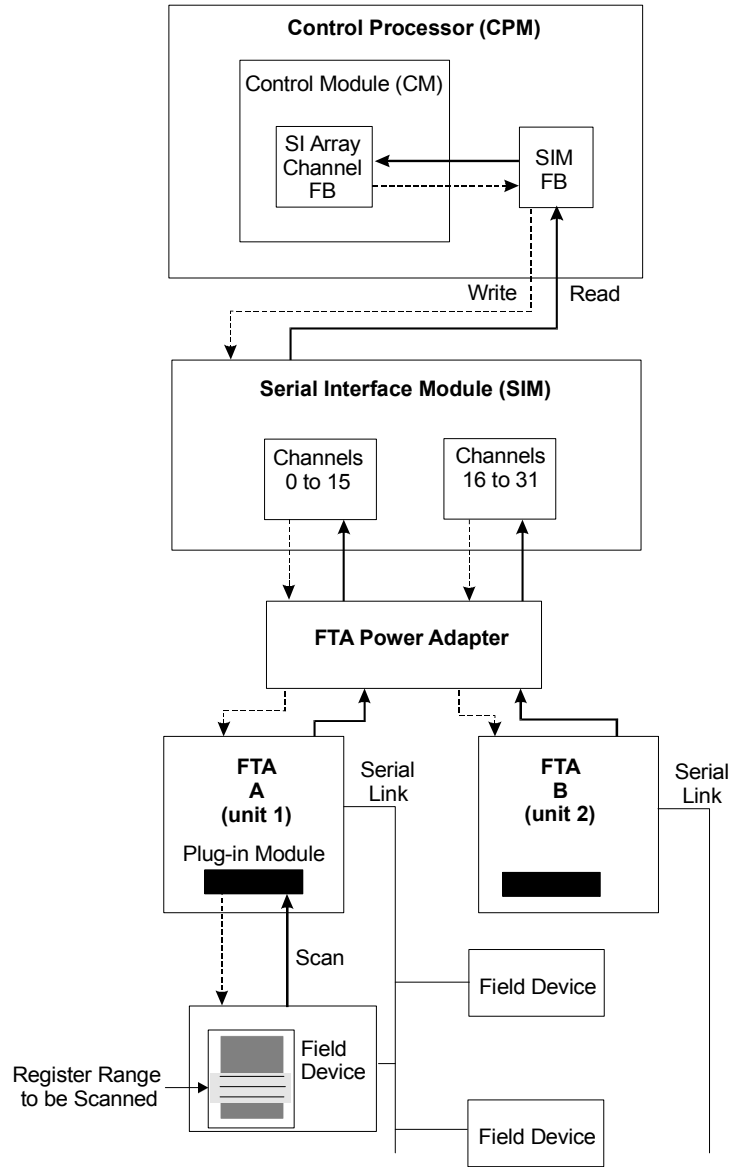

Figure 1 Signal Path between Serial Field Device and Serial Interface Array Channel Function Block.

General Implementation Considerations

The following is a list of things to consider when implementing a serial interface.

- A CPM with CEE-50ms can support up to three SIMs, or only one SIM with CEE-5ms.
- The fastest update rate supported by the SIM is 250 milliseconds.
- A remote I/O chassis power supply will support up to three SIMs.
- A Controller chassis power supply will support up to two SIMs, since the CPM consumes roughly the same power as a SIM.
- The SIM supports up to two serial ports or two FTAs with up to 16 serial devices per FTA.
- The CPM with CEE-50ms supports up to 64 IOM connections or only 12 IOM connections with CEE-5ms.
- A SIM supports a maximum of 32 SI Array Channel FBs through a SIM FB with no restrictions on the mix of Array Channel FB data types.
- A Serial Interface NUMERIC Array Channel FB supports up to 64 numeric process variables.
- A Serial Interface FLAG Array Channel FB supports up to 512 process variable flags.
- A Serial Interface TEXT Array Channel FB supports up to 64 Unicode characters.
- Each SI Array Channel FB is mapped to a single serial device. (Note that multiple SI Array Channel FBs can be mapped to a single serial device.)
- Every four SI Array Channel FBs associated with a given SIM FB are equivalent to using one traditional analog/discrete IOM. A single rack-mounted SIM can represent from 1 to 8 traditional IOMs, in terms of the maximum IOM capacity, based on a ratio of four Array Channel FBs equal one traditional IOM.
- The 32 Array Channel FBs associated with a SIM FB are allocated to the two FTAs as follows.
 - Channels 0 to 15 to FTA “**A**”
 - Channels 16 to 31 to FTA “**B**”

- When only one FTA is used, it must be configured as FTA “A” and channels 0 to 3 must be used for at least one connection.
- An FTA serial port operates at a data rate of up to 19.2 kilobaud.
- Communication between the SIM and the FTA operates at 38.4 kilobaud.
- The FTA to Power Adapter cable can be up to 300 meters (1000 feet) long.
- The Power Adapter to SIM cable can only be up to 3 meters (10 feet) long.
- Be sure the 24Vdc power supply that is used to power the TC/TK-SMPD01 SIM FTA Power Adapter is **dedicated** to powering only that Power Adapter and is **not** used to power any other equipment. The power supply must also be a floating power source, such as a DIN rail-mounted Phoenix Contact (MCR-PS-24DC/24DC/200) power supply with floating 24Vdc output.

SIM processing characteristics

The periodic execution of an active SIM FB takes care of processing the following three primary actions.

- Load SI Array Channel FB configurations to the SIM.
- Send Array Channel FB write requests to the SIM.
- Monitor status of the SIM and report any diagnostics.

These three actions are processed once during every SIM 250 ms publication period.

Imaging of the data configured in the SI Array Channel FB is done as part of the Channel block’s execution and not as part of the SIM block’s execution. But, the Channel block cannot access the imaged data, when the SIM FB is inactive. In this case, the Channel block sets its data to the applicable default value.

The SIM FB collects the writes for each Channel and sends them to the SIM every 250 ms. It is possible that a write to a Channel block is rejected because the SIM FB’s write list is full. The following table summarizes the maximum number of writes a SIM FB supports per Channel per 250 ms period.

Serial Interface Module Implementation Overview

SI Array Channel FB Data Type	Maximum number of writes supported per Channel per 250 ms period
Numerics	8
Flags	16
8-Character Strings	8
16-Character Strings	4
32-Character Strings	2
64-Character Strings	1

Writes to the Channel blocks can also be rejected because the SIM is not keeping up with the writes being sent by the SIM FB. The SIM FB uses a write sequence number on a per channel basis for each write command to the SIM. Upon receipt of the write command, the SIM echoes back the last write sequence number processed. When the sequence numbers get too far apart, the Channel block rejects further writes.

Note that writes can degrade read performance to as little as one array update per second. Actual performance depends on Baud Rate and Device Protocol as well as responsiveness of the field device. You can check read/write performance and overrun statistics by viewing SIM details through the Network Tools (NTOOLS) application provided with Experion Engineering Tools.

The SIM FB non-alarming parameters FTAAOVRNFL and FTABOVRNFL indicate write overruns. You can monitor these parameters through the SIM Detail display in Station. To alarm on the overrun condition, connect the overrun parameter to a FLAG FB, which can generate an OffNormal alarm.

Where to look for more information

This document is only intended as a supplement to the existing data that is included in the Experion Knowledge Builder online documentation. The following table summarizes the location of related information for handy reference.

If you are looking for information about. . .	Then, go to . . .
Planning the installation of a Experion system that includes a SIM.	The Planning Guide <i>Control Hardware Configuration</i> <i>Planning Your I/O Modules and Remote Termination Panels</i> <i>Serial Interface Module (SIM) planning</i> topic in Knowledge Builder.
Installing a SIM in a Experion chassis.	The Control Hardware Installation Guide <i>Serial Interface Module Installation and Removal</i> topic in Knowledge Builder.
Installing a Power Adapter.	Same as above.
Removing a SIM or Power Adapter.	Same as above.
Installing a Modbus or A-B FTA.	The <i>Modbus or A-B FTA Installation</i> section in this document.
Adding a SIM FB to the Project tab.	The Control Building Guide <i>Control Builder Operations</i> <i>Creating an instance of Input/Output Modules</i> topic in Knowledge Builder.
Configuring the SIM FB.	The Control Building Guide <i>Configuring Modules</i> <i>Configuring the Serial Interface Module</i> topic in Knowledge Builder.

Serial Interface Module Implementation
Overview

If you are looking for information about. . .	Then, go to . . .
Adding an SI Array Channel FB to a Control Module	The Control Building Guide <i>Control Module Creation</i> <i>Creating an Instance of a Basic Function Block</i> topic in Knowledge Builder.
Configuring an SI Array Channel FB for use with an A-B FTA.	The online Help and the Allen-Bradley Interface Appendix A in this document.
Configuring an SI Array Channel FB for use with a Modbus FTA.	The online Help and the MODBUS Interface Appendix B in this document.
Assigning SIM FB to the CEE.	The Control Building Guide <i>Control Module Creation</i> <i>Assigning CMs and IOMs to CEE</i> topic in Knowledge Builder.
Associating SI Array Channel FB with SIM FB.	The Control Building Guide <i>Control Builder Operations</i> <i>Associating I/O Channels to I/O Modules (IOMs)</i> topic in Knowledge Builder.
Updating firmware in the SIM.	The Start-up and Shutdown Guide <i>System Startup/ Restart</i> <i>Restarting System After a Component Failure</i> <i>Loading SIM personality image - optional</i> topic in Knowledge Builder.
Interpreting SIM front panel indicators	The Troubleshooting and Maintenance Guide <i>Front Panel Indicators</i> <i>Serial Interface Modules</i> topic in Knowledge Builder.

If you are looking for information about. . .	Then, go to . . .
Checking SIM read/write and overrun statistics.	The Troubleshooting and Maintenance Guide <i>Tools and Utilities</i> <i>NetworkTools</i> <i>Viewing SIM statistics</i> topic in Knowledge Builder.
The specifications for the SIM.	The Experion Specifications The Experion specifications can be found on the Honeywell Process Solutions web site. After you log in, select Products>Systems>Experion PKS, key in Spec in the Document Search box, and click the arrow icon to initiate the search.
The specifications for A-B FTA interface.	The Allen-Bradley Interface Appendix A in this document.
The specifications for the Modbus FTA interface.	The MODBUS Interface Appendix B in this document.

MODBUS FTA Installation

Overall Modbus interface connections

Figure 2 shows the typical component connections associated with a Modbus FTA installation for reference.

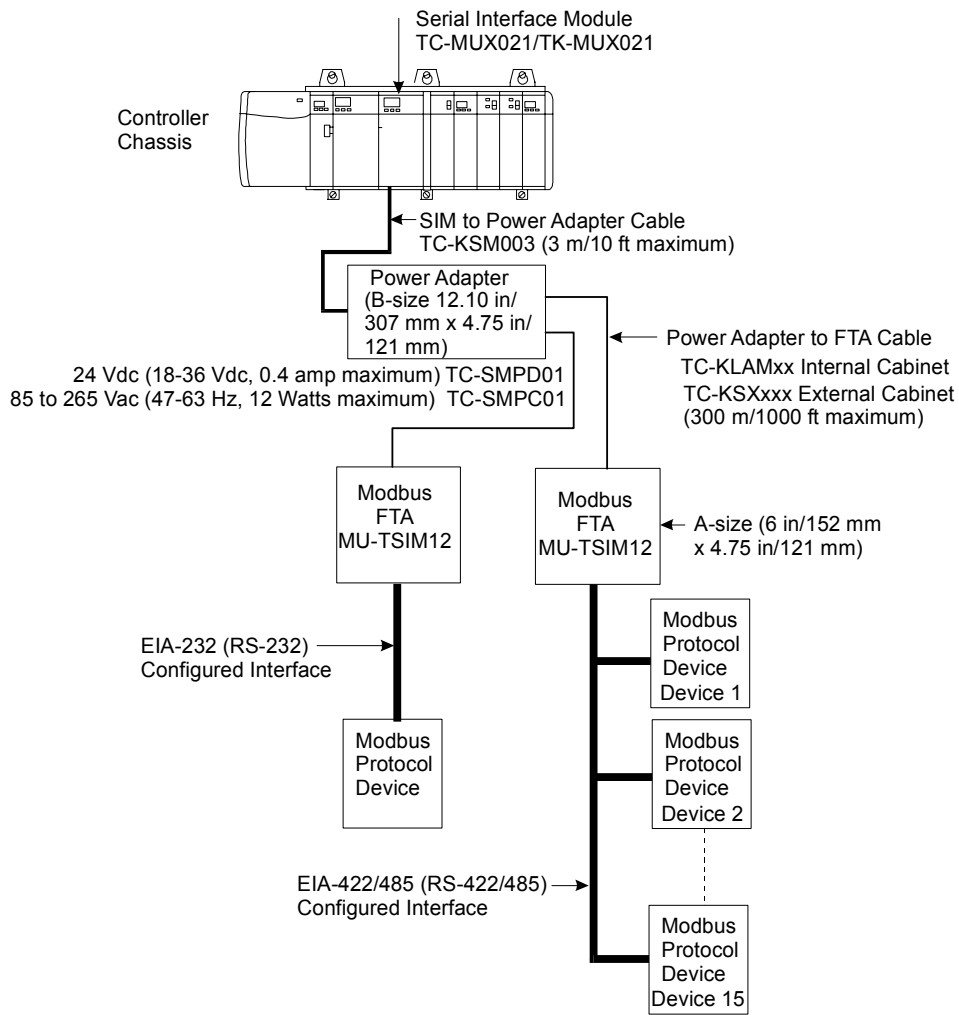

Figure 2 Modbus Serial Interface connections

Mounting Modbus FTA

The Modbus FTA can be mounted on a standard FTA Mounting Channel, DIN rail (35 x 7.5 mm top hat rail), or surface mounted on a wall. The FTA is designed for mounting in a cabinet or a controlled environment. Do **not** expose the FTA to the weather.

The FTA has a mounting hole in each corner. To mount on a DIN rail, you must attach the DIN rail adapter to the bottom of the FTA, using the hardware supplied. Otherwise, mount the FTA on Mounting Channel standoffs or drill holes and use screws and non-metallic spacers to attach the FTA to a wall. Be sure the FTA is grounded either directly or through the mounting means.

Wiring Modbus FTA to Power Adapter

Use the procedure in the following table to wire the Modbus FTA to the Power Adapter.

Step	Action
1	<p>Is the Modbus FTA mounted in a cabinet with the Power Adapter?</p> <ul style="list-style-type: none">• If the answer is Yes, be sure you have the appropriate number and length of Honeywell internal cable MU-KLAMxx on hand. Go to the next Step.• If the answer is No, be sure you have the appropriate number and length of Honeywell external cable MU-KSXxxx on hand. Go to the next Step. <p>(Note that the cable must have two individually shielded, twisted pairs.)</p>
2	<p>On one twisted pair mark one lead P– and the other P+ at both ends of the cable. On the other twisted pair mark one lead S– and the other S+ at both ends of the cable. Repeat this for other cables, as applicable.</p>
3	<p>Locate the J2 (CHANNEL A), 6-pin connector on the Power Adapter. Observing polarity, connect the cable lead marked P– to pin 1 – PWR CUR and lead marked P+ to pin 2 + PWR CUR. Connect the shield wire for this pair to pin 3 SHD. Observing polarity, connect the cable lead marked S– to pin 4 – SER and lead marked S+ to pin 5 + SER. Connect the shield wire for this pair to pin 6 SHD. See the connection diagram in Figure 3 for reference.</p> <p>(Note that the shield wires are connected to ground at the Power Adapter end only.)</p>

Serial Interface Module Implementation

MODBUS FTA Installation

Step	Action
4	Locate the J1, 4-pin connector on the FTA "A". Observing polarity, connect the cable lead marked P- to pin 1 – PWR CUR and lead marked P+ to pin 2 + PWR CUR. Trim the shield wire for this pair close to the cable insulation. Observing polarity, connect the cable lead marked S- to pin 3 – SER and lead marked S+ to pin 4 + SER. Trim the shield wire for this pair close to the cable insulation. See the connection diagram in Figure 3 for reference.
5	Do you have a second FTA to be connected to the Power Adapter? <ul style="list-style-type: none">• If the answer is Yes, continue with Step 6.• If the answer is No, exit this procedure and go to the next section <i>Wiring Modbus FTA to Modbus devices</i>.
6	Locate the J3 (CHANNEL B), 6-pin connector on the Power Adapter. Observing polarity, connect the cable lead marked P- to pin 1 – PWR CUR and lead marked P+ to pin 2 + PWR CUR. Connect the shield wire for this pair to pin 3 SHD. Observing polarity, connect the cable lead marked S- to pin 4 – SER and lead marked S+ to pin 5 + SER. Connect the shield wire for this pair to pin 6 SHD. See the connection diagram in Figure 3 for reference. (Note that the shield wires are connected to ground at the Power Adapter end only.)
7	Locate the J1, 4-pin connector on the FTA "B". Observing polarity, connect the cable lead marked P- to pin 1 – PWR CUR and lead marked P+ to pin 2 + PWR CUR. Trim the shield wire for this pair close to the cable insulation. Observing polarity, connect the cable lead marked S- to pin 3 – SER and lead marked S+ to pin 4 + SER. Trim the shield wire for this pair close to the cable insulation. See the connection diagram in Figure 3 for reference.
8	Go to the next section <i>Wiring Modbus FTA to Modbus devices</i> .

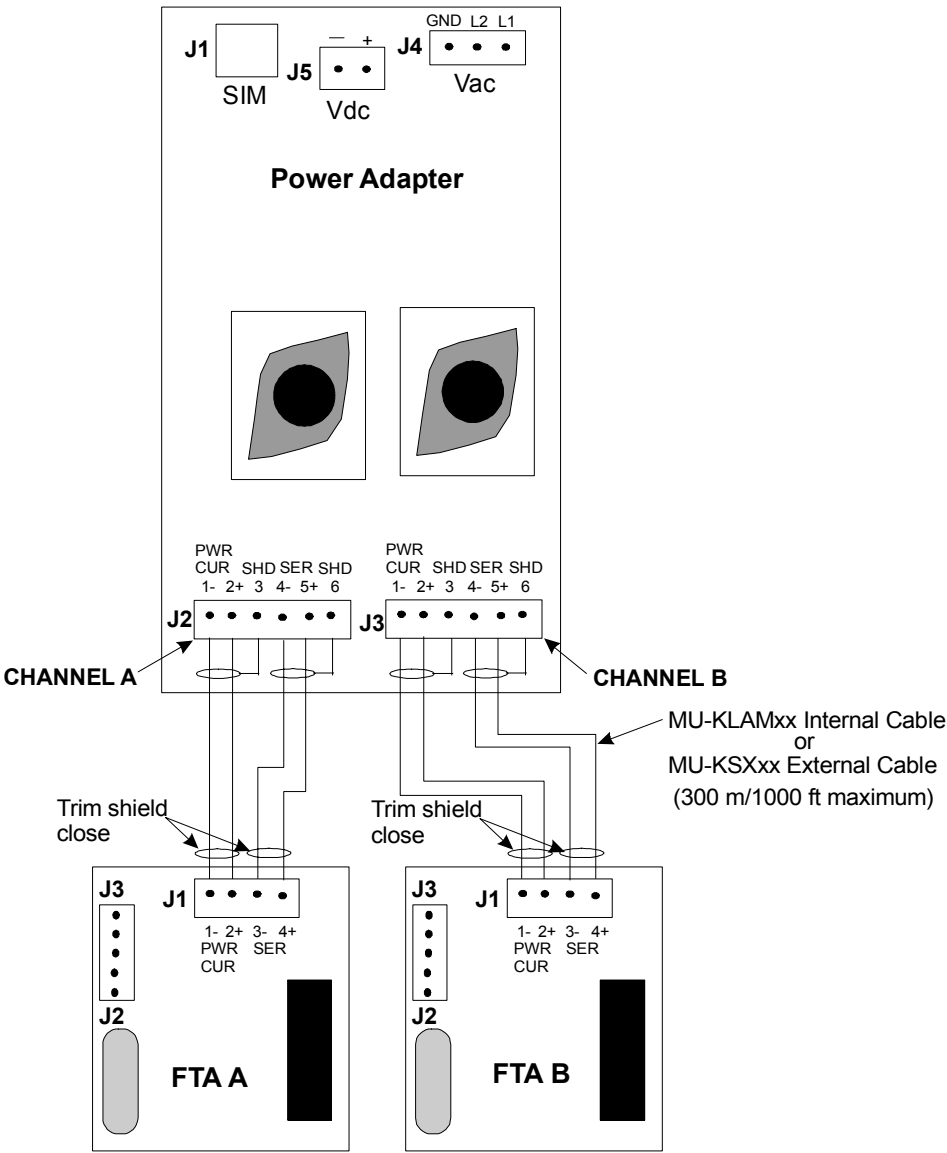

Figure 3 Power Adapter to Serial Interface FTA Wiring

Wiring Modbus FTA to Modbus Devices

Making EIA-232 (RS-232) connections

You will need a null modem cable with a 25-pin, male connector to connect the EIA-232 Modbus device to the J2, DB-25 type connector on the FTA. Use the J2 connector pinout data in Figure 4 to construct the EIA-232 interface cable. Since individual Modbus device connections may vary, be sure to modify the common EIA-232 pinouts shown in Figure 4, so that the FTA Transmit Data pin (2) connects to the Modbus device Receive Data pin and the FTA Receive Data pin (3) connects to the Modbus device Transmit Data pin. Be sure the length of the EIA-232 interface cable does not exceed 15 meters (50 feet).

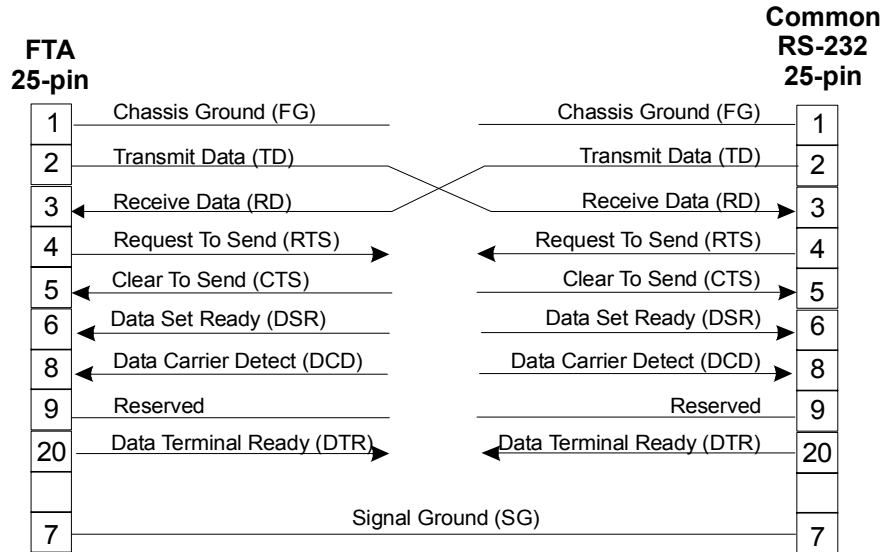

Figure 4 Pins common to RS-232 25-pin connector and FTA J2, DB-25 type connector.

Making EIA-422/485 connections

You will need appropriate cable, such as Belden Corporation type 9271 twinaxial, to connect up to 15 EIA-422/485 Modbus devices in multidrop fashion to the J3, 5-pin connector on the FTA. Use the connection details shown in Figure 5 and the following guidelines to configure a multidrop EIA-422/485 interface.

The recommended maximum length for the interface cable is 300 meters (1000 feet). However, this can be extended up to 1220 meters (4000 feet) with the appropriate cable (Belden type 9182). Please consult with your Honeywell representative for the recommended cable.

To avoid potential ground loops, connect the shield for the interface cable to ground at the FTA end only. See Figure 5 for details.

To minimize signal reflections, connect a 120 ohm, +/- 10%, ½ Watt resistor across J3 pins 1 and 5 and across the Data + and Data – terminals on the last device in the link. (Note that the resistor value may be different based on the requirements of the actual cable used.)

The FTA includes two ¼ Ampere fuses (F1 and F2) to protect it from excessive current on the data lines.

Serial Interface Module Implementation
MODBUS FTA Installation

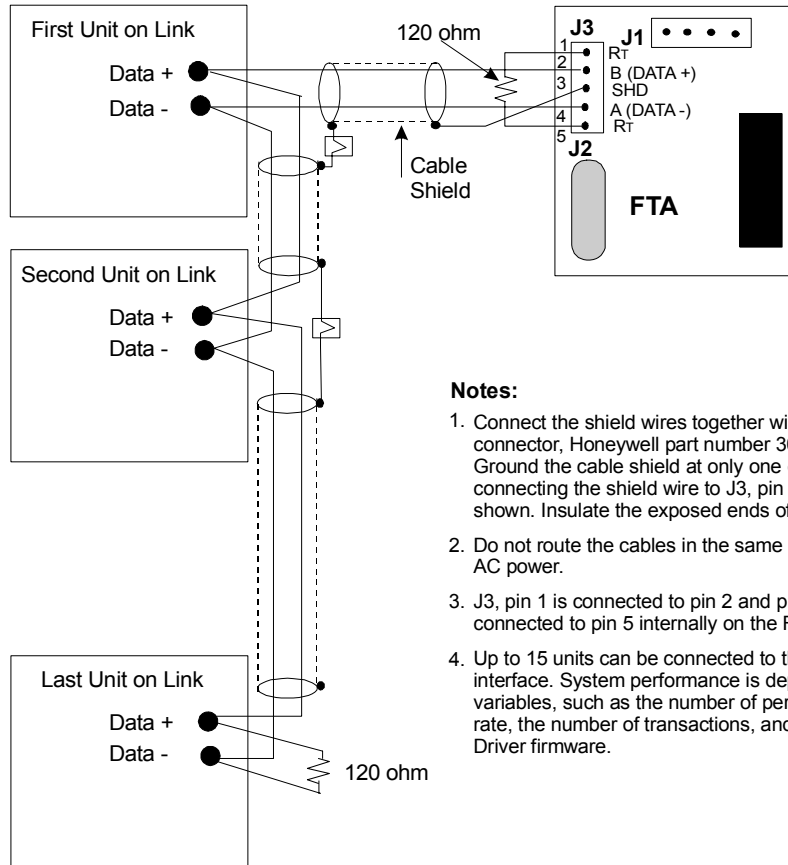

Notes:

1. Connect the shield wires together with a crimp connector, Honeywell part number 30755381-001. Ground the cable shield at only one end by connecting the shield wire to J3, pin 3 on the FTA as shown. Insulate the exposed ends of the shield wire.
2. Do not route the cables in the same conduit or tray as AC power.
3. J3, pin 1 is connected to pin 2 and pin 4 is connected to pin 5 internally on the FTA.
4. Up to 15 units can be connected to the EIA-422/485 interface. System performance is dependent on several variables, such as the number of peripherals, the baud rate, the number of transactions, and the FTA Device Driver firmware.

Figure 5 Modbus FTA EIA-422/485 connections.

ALLEN-BRADLEY FTA Installation

Overall Allen-Bradley interface connections



ATTENTION

Connections and options are subject to change by Allen-Bradley without notice to or from Honeywell. Please Contact Allen-Bradley for the latest interface.

Figures 6 and 7 show the typical component connections associated with an Allen-Bradley FTA installation for reference.

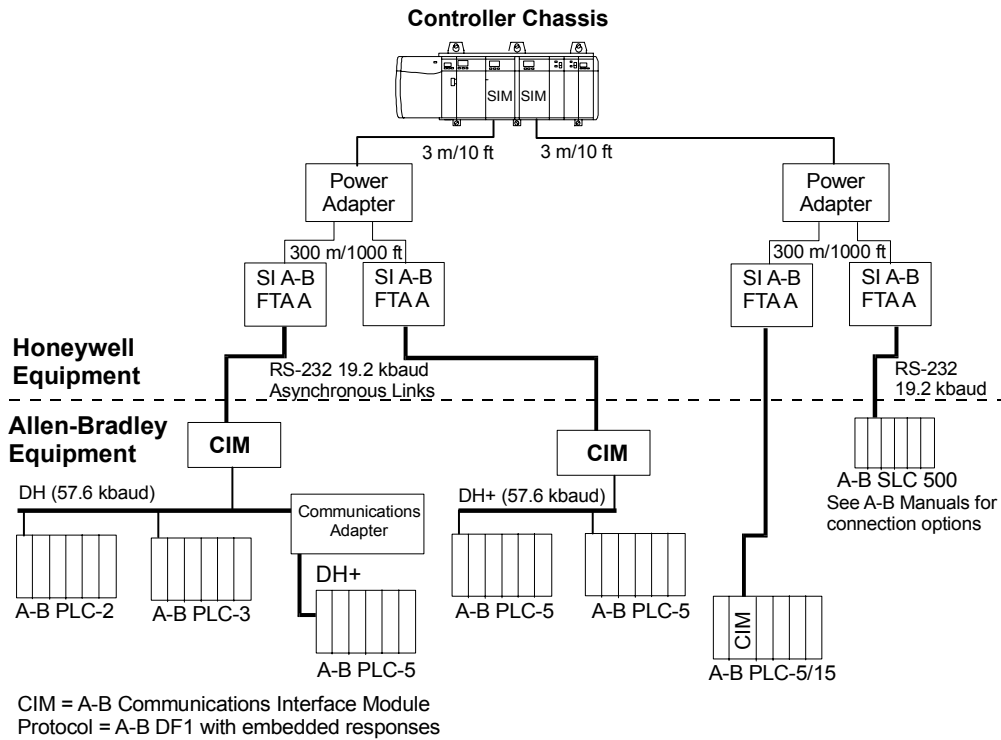

Figure 6 Typical connection of Allen-Bradley devices to the SIM.

Serial Interface Module Implementation
ALLEN-BRADLEY FTA Installation

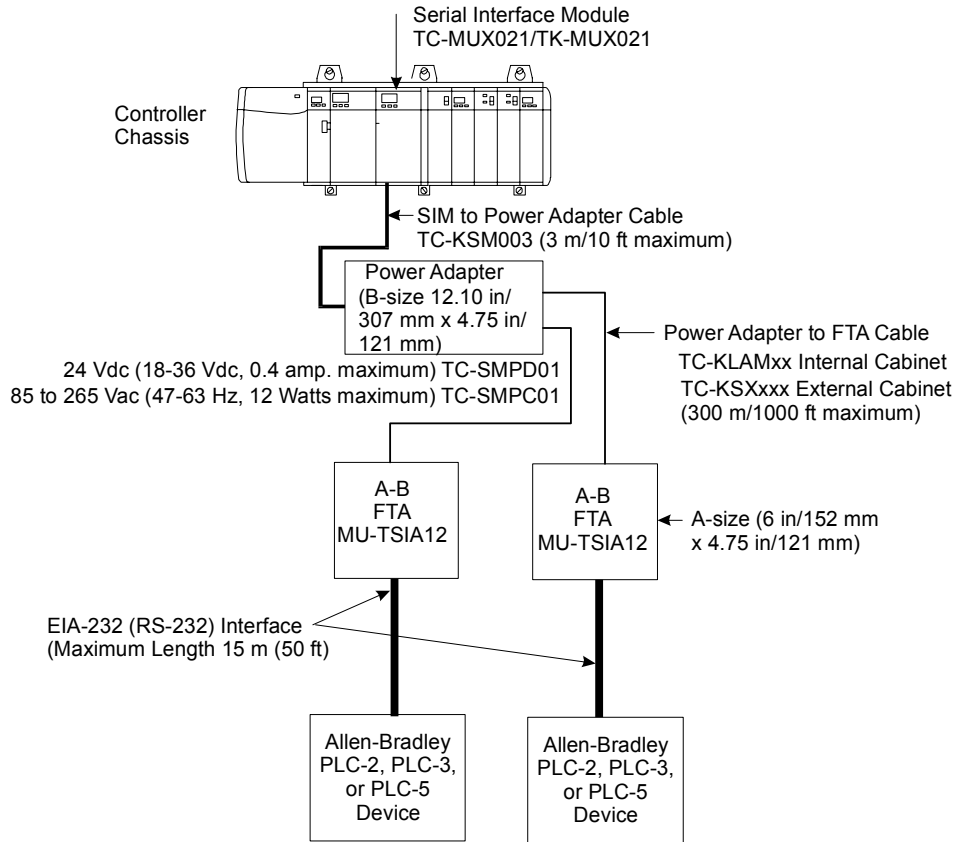

Figure 7 Allen-Bradley Serial Interface connections.

Mounting Allen-Bradley FTA

The Allen-Bradley FTA can be mounted on a standard FTA Mounting Channel, DIN rail (35 x 7.5 mm top hat rail), or surface mounted on a wall. The FTA is designed for mounting in a cabinet or a controlled environment. Do **not** expose the FTA to the weather.

The FTA has a mounting hole in each corner. To mount on a DIN rail, you must attach the DIN rail adapter to the bottom of the FTA, using the hardware supplied. Otherwise, mount the FTA on Mounting Channel standoffs or drill holes and use screws and non-metallic spacers to attach the FTA to a wall. Be sure the FTA is grounded either directly or through the mounting means.

Wiring Allen-Bradley FTA to Power Adapter

Use the procedure in the following table to wire the A-B FTA to the Power Adapter.

Step	Action
1	<p>Is the A-B FTA mounted in a cabinet with the Power Adapter?</p> <ul style="list-style-type: none">• If the answer is Yes, be sure you have the appropriate number and length of Honeywell internal cable MU-KLAMxx on hand. Go to the next Step.• If the answer is No, be sure you have the appropriate number and length of Honeywell external cable MU-KSXxxx on hand. Go to the next Step. <p>(Note that the cable must have two individually shielded, twisted pairs.)</p>
2	<p>On one twisted pair mark one lead P– and the other P+ at both ends of the cable. On the other twisted pair mark one lead S– and the other S+ at both ends of the cable. Repeat this for other cables, as applicable.</p>
3	<p>Locate the J2 (CHANNEL A), 6-pin connector on the Power Adapter. Observing polarity, connect the cable lead marked P– to pin 1 – PWR CUR and lead marked P+ to pin 2 + PWR CUR. Connect the shield wire for this pair to pin 3 SHD. Observing polarity, connect the cable lead marked S– to pin 4 – SER and lead marked S+ to pin 5 + SER. Connect the shield wire for this pair to pin 6 SHD. See the connection diagram in Figure 3 for reference.</p> <p>(Note that the shield wires are connected to ground at the Power Adapter end only.)</p>
4	<p>Locate the J1, 4-pin connector on the FTA “A”. Observing polarity, connect the cable lead marked P– to pin 1 – PWR CUR and lead marked P+ to pin 2 + PWR CUR. Trim the shield wire for this pair close to the cable insulation. Observing polarity, connect the cable lead marked S– to pin 3 – SER and lead marked S+ to pin 4 + SER. Trim the shield wire for this pair close to the cable insulation. See the connection diagram in Figure 3 for reference.</p>
5	<p>Do you have a second A-B FTA to be connected to the Power Adapter?</p> <ul style="list-style-type: none">• If the answer is Yes, continue with Step 6.• If the answer is No, exit this procedure and go to the next section <i>Wiring A-B FTA to Allen-Bradley devices</i>.

Serial Interface Module Implementation
ALLEN-BRADLEY FTA Installation

Step	Action
6	<p>Locate the J3 (CHANNEL B), 6-pin connector on the Power Adapter. Observing polarity, connect the cable lead marked P- to pin 1 – PWR CUR and lead marked P+ to pin 2 + PWR CUR. Connect the shield wire for this pair to pin 3 SHD. Observing polarity, connect the cable lead marked S- to pin 4 – SER and lead marked S+ to pin 5 + SER. Connect the shield wire for this pair to pin 6 SHD. See the connection diagram in Figure 3 for reference.</p> <p>(Note that the shield wires are connected to ground at the Power Adapter end only.)</p>
7	<p>Locate the J1, 4-pin connector on the FTA “B”. Observing polarity, connect the cable lead marked P- to pin 1 – PWR CUR and lead marked P+ to pin 2 + PWR CUR. Trim the shield wire for this pair close to the cable insulation. Observing polarity, connect the cable lead marked S- to pin 3 – SER and lead marked S+ to pin 4 + SER. Trim the shield wire for this pair close to the cable insulation. See the connection diagram in Figure 3 for reference.</p>
8	<p>Go to the next section <i>Wiring A-B FTA to Allen-Bradley devices</i>.</p>

Wiring A-B FTA to Allen-Bradley Devices

You will need a null modem cable with a 25-pin, male connector to connect the EIA-232 Allen-Bradley device to the J2, DB-25 type connector (female) on the FTA. Use the J2 connector pinout data in Figure 4 to construct the EIA-232 interface cable. Since individual A-B device connections may vary, be sure to modify the common EIA-232 pinouts shown in Figure 4, so that the FTA Transmit Data pin (2) connects to the A-B device Receive Data pin and the FTA Receive Data pin (3) connects to the A-B device Transmit Data pin. Refer to the pinout description in the Allen-Bradley device manual and the [Special FTA to KE/KF cabling considerations](#) in *Appendix A*. Observe the following general cabling guidelines.

- The FTA, J2 connector, Transmit pin 2 must connect to the A-B device Receive pin.
- The FTA, J2 connector, Receive pin 3 must connect to the A-B device Transmit pin.
- Never connect the Chassis and Signal grounds together.
- The A-B device may require other pins to be jumpered, refer to the A-B device manual and the [FTA direct to PLC-5 RS-232 Port cable considerations](#) in *Appendix A*.
- When connecting to an A-B PLC, usually through a KE or KA module, be sure the device has the latest firmware available from Allen-Bradley.
- Be sure the length of the EIA-232 interface cable does not exceed 15 meters (50 feet).

Allen-Bradley Interface Appendix A

Array Channel Block Configuration for Allen-Bradley Interface

About Allen-Bradley interface

The Serial Interface Array Channel function blocks communicate with Allen-Bradley Programmable Logic Controllers (PLC) through the Serial Interface I/O Module (SIM).

The SIM communicates with the Allen-Bradley (A-B) FTA. The A-B FTA communicates with the Allen-Bradley KE/KF Computer Interface Module (CIM) using EIA-232-D protocol at 19,200 baud with even parity. The KE/KF module communicates with PLCs on an Allen-Bradley Data Highway or Data Highway Plus using DF1 protocol with embedded responses. Direct connection to the PLC-5 RS-232 port is also supported. Refer to Allen-Bradley Data Highway protocol manuals for details.

The Allen-Bradley PLC families supported are PLC-2, PLC-3, and PLC-5. The PLC-5 family consists of the 5/10, 5/15, 5/25, 5/40, and 5/60 models.

AUXDATA parameter configuration

The following table summarizes the AUXDATA parameter configuration that defines Serial Interface Array Channel block communications with the Allen-Bradley PLC.



ATTENTION

When the AUXDATA[0...7] parameters are not being used with a Allen-Bradley interface, they should be set to the default value of NaN (Not a Number).

Allen-Bradley Interface Appendix A

Array Channel Block Configuration for Allen-Bradley Interface

Parameter	Function	Description
AUXDATA[0] to AUXDATA[3]	These parameters are not applicable to an Allen-Bradley interface.	Set these parameters to NaN when communicating with an Allen-Bradley PLC.
AUXDATA[4]	Specifies the Allen-Bradley PLC family type.	<p>Use the following setting for a given PLC type.</p> <ul style="list-style-type: none">• 2.0 for PLC-2 type• 3.0 for PLC-3 type• 5.0 for PLC-5 type <p>You can access different PLC family types through the same FTA by using multiple Serial Interface Array Channel blocks with the desired family type setting specified for each Array Channel block's AUXDATA[4] parameter.</p> <p>You can access PLC-3 or PLC-5 type controllers using PLC-2 emulation by setting the AUXDATA[4] parameter value to 2.0.</p> <p>For diagnostic related Array Channel blocks, you must set the AUXDATA[4] parameter to "0" for a Computer Interface Module or "NaN" for a loopback test. See the following section <i>Diagnostic data configuration</i> for details.</p>
AUXDATA[5]	Specifies the Allen-Bradley PLC file number.	<p>Use the following setting for a given PLC type.</p> <ul style="list-style-type: none">• NaN for PLC-2 type• 0 to 999 for PLC-3 or PLC-5 type <p>For diagnostic related Array Channel blocks, you must set the AUXDATA[5] parameter to "-1" for a Computer Interface Module or PLC type, or "-3" for a loopback test. See the following section <i>Diagnostic data configuration</i> for details.</p>
AUXDATA[6]	Specifies the data type for Allen-Bradley PLC -2 or PLC-5 type or the section ID for a PLC-3 type.	<p>See the paragraph following this table for details about making AUXDATA[6] settings for a given PLC type.</p> <p>Different settings are required for diagnostic related Array Channel blocks. See the following section <i>Diagnostic data configuration</i> for details.</p>

Allen-Bradley Interface Appendix A
 Array Channel Block Configuration for Allen-Bradley Interface

Parameter	Function	Description
AUXDATA[7]	Specifies the Allen-Bradley PLC scan rate.	<p>Each Array Channel block can have a different scan rate. The Allen-Bradley interface supports either polling or Report by Exception (RBE) independent of the scan rate. Use the following setting for a given scan rate.</p> <ul style="list-style-type: none"> • 0 to scan the channel as fast as possible • 1 to 255 to scan the channel once every 1 to 255 seconds • 256 to scan the channel once after configuration or after link or device failure recovery (then only Report by Exception) <p>Notes:</p> <ol style="list-style-type: none"> a) Use higher priority scanning for time-critical data, and slower scanning or RBE for lower priority channels where data changes infrequently. b) If all channels are set for very fast scan (0 to 2 seconds), actual performance may be less than one update per second, especially when writes are used. c) A setting greater than 256 causes a POL FREQ error. d) If more than one Array Channel block is configured to map the same PLC memory area, only one of the blocks will be updated with RBE data. e) After the first scan is completed with a setting of 256, Array data is updated when RBE data is received for that channel or after any communication error (but not after configuration errors). f) The RBE feature is independent of the scan rate. See the section Report by Exception requirements for details.

AUXDATA[6] parameter setting details

The following tables list the AUXDATA[6] parameter settings required for a given data type and A-B PLC type. It also lists the Array Channel block associated with a given data type as well as the data range and maximum number of elements.



WARNING

An unexpected write may take place when changing AuxData[6] (data type) online, in the following scenario:

1. Data Type was 4 or 5 (read only unsigned).
2. An online value change was attempted. The change is ignored.
3. Data Type is changed to other writable numeric type.

The previously-attempted change is now accepted and passed to the PLC.

- PLC-2 type settings:

Data Type	AUXDATA[6] Setting	Array Channel Function Block	Data Range	Max. No. Elem.
Output	0	SIFLAGARRCH	ON/OFF	512
Input	1	SIFLAGARRCH	ON/OFF	512
Status	2	SIFLAGARRCH	ON/OFF	512
Bit	3	SIFLAGARRCH	ON/OFF	512
Integer	4,5	SINUMARRCH (unsigned 16 Bit)	0 to 65535	32
Floating Point	6	Unsupported (VAX F Format)	–	–
Integer	7	SINUMARRCH (signed 16 Bit)	-32768 to 32767	32
Floating Point	8	SINUMARRCH (IEEE Single Precision)	-34E38 to 34E38	16

Allen-Bradley Interface Appendix A
Array Channel Block Configuration for Allen-Bradley Interface

ASCII	9	SITEXTARRCH	Printable Characters	8 of 8 4 of 16 2 of 32 1 of 64
<p>Note: The PLC-2 controller only recognizes status or integer data types. The interface handles other data types by requesting single or multiple elements for integer data according to the AUXDATA[6] setting. The SIM does not support the VAX F format.</p>				

- PLC-3 type settings:

Data Type	AUXDATA[6] Setting	Array Channel Function Block	Data Range	Max. No. Elem.
Output	1	SIFLAGARRCH	ON/OFF	512
Input	2	SIFLAGARRCH	ON/OFF	512
Integer	5	SINUMARRCH (signed 16 Bit)	-32768 to 32767	32
Floating Point	6	Unsupported (VAX F Single Precision)	–	–
Binary	8	SIFLAGARRCH	ON/OFF	512
ASCII	9	SITEXTARRCH	Printable Characters	8 of 8 4 of 16 2 of 32 1 of 64
Status	13	SIFLAGARRCH	ON/OFF	512
<p>Notes:</p> <p>g) The setting for AUXDATA[6] corresponds to the PLC-3 controller Section Identifier.</p> <p>h) The PLC-3 controller does not support these data types: timers, counters, decimal, high order (two word) integers, and pointers.</p> <p>i) The SIM does not support the VAX F format.</p>				

Allen-Bradley Interface Appendix A
 Array Channel Block Configuration for Allen-Bradley Interface

- PLC-5 type settings:

Data Type	AUXDATA[6] Setting	Array Channel Function Block	Data Range	Max. No. Elem.
Output	0	SIFLAGARRCH	ON/OFF	512
Input	1	SIFLAGARRCH	ON/OFF	512
Status	2	SIFLAGARRCH	ON/OFF	512
Bit	3	SIFLAGARRCH	ON/OFF	512
Integer	* 4,5	SINUMARRCH (unsigned 16 Bit)	0 to 65535	32
Integer	7	SINUMARRCH (signed 16 Bit)	-32768 to 32767	32
Floating Point	8	SINUMARRCH (IEEE Single Precision)	-34E38 to 34E38	16
ASCII	9	SITEXTARRCH	Printable Characters	8 of 8 4 of 16 2 of 32 1 of 64

* These Allen-Bradley file types are read only and writes to them are ignored.

Notes:

- j) The setting for AUXDATA[6] corresponds to the PLC-5 controller file type, except 9 is assigned for string data. Configure the PLC-5 file to use data type 'A' (ASCII), not data type 'ST' (string).
- k) Timers/counters require three words per timer/counter. Presets and accumulated values are read only. They can only be modified in ladder logic.
- l) The following restrictions also apply for PLC-5:
 - If the AUXDATA[5] setting is 0, then AUXDATA[6] must be set to 0 (output data).
 - If the AUXDATA[5] setting is 1, then AUXDATA[6] must be set to 1 (input data).
 - If the AUXDATA[5] setting is 2, then AUXDATA[6] must be set to 2 (status).

DEVADDR parameter configuration

You configure the device address (DEVADDR) parameter to specify the Node Address for the A-B PLC in octal. For example, if the PLC Node Address is 75₈, enter 75 as the device address setting in the Array Channel block configuration form. More than one Array Channel block can have the same device address.

The valid Node Address range is 0₈ to 376₈. (Note that the FTA firmware does the octal to decimal conversion automatically, so do **not** convert the octal address to decimal.)

STARTINDEX and number of elements parameters configuration

The value configured for the STARTINDEX parameter in a given Array Channel block determines the PLC data table location and function. Only one type of external data (Flag, Numeric, or String) can be accessed per Array Channel block. The following paragraphs describe the setting considerations for a given PLC type.

- **PLC-2** Type: Use the appropriate octal address within the PLC-2 data table. For example, if the octal address is 176₈, enter 176 as the start index setting in the Array Channel block configuration form.
- **PLC-3** Type: Use either the word part of the PLC-3 address or the structure value for the floating point data. For all data types except input/output (I/O), the decimal range is 0 to 9999₁₀. For I/O data, enter the start index setting in the Array Channel block configuration form as an octal number. The range for actual I/O is 0₈ to 377₈ and the range for storage locations is 400₈ to 7777₈.

The PLC-3 Context and External Data Tables are only supported to the extent that Context is fixed equals 1 (current context) and the External Data Table is always equal to E3.

- **PLC-5** Type: Use the file start index depending on the type of data (Flag, Numeric, String).

For flag data, the start index setting represents the word address within the file. If the AUXDATA[6] setting is 0 (Output) or 1 (Input), enter the start index for a Flag Array Channel block as an octal number in the range of 000₈ to 177₈. A non-octal digit or an out-of-range value causes a STARTIDX error.

Specify all other start index settings as integers, including flag array data except as noted above for input or output data type. The SIM does not check file size.

The number of elements parameter (NFLAG, NNUMERIC, or NSTRING) in a Flag Array, Numeric Array, or Text Array Channel block determines the number of flags, numerics, or strings in a given data array. The tables in *AUXDATA[6] parameter setting details* section list the maximum number of elements for a given data type for reference.

Report by Exception requirements

Before an FTA will accept RBE data, the following conditions must be true.

- The corresponding Array Channel block must be configured.
- The channel must have been scanned at least once.
- The sending device's source address (SRC) must match the Array Channel block's configured device address (DEVADDR) parameter.
- The quantity of the data received by the FTA in an RBE request must match the quantity of the data configured for the destination Array Channel block.
- The command code (CMD) and the function number (FNC) in the Allen-Bradley communication messages must be as specified in the following table.
- An RBE_FULL error results if even one RBE message is rejected without indication back to the device that generated the message.
- RBE data is rejected by any Array Channel block configured to map diagnostic counter data, or run a diagnostic loop, or by any PLC-5 configured for Timer/Counter data.
- For a PLC-5 controller, the Data Type (AUXDATA[6]) parameter must match the file type start index configured for the destination Array Channel block.

Note that configuring more than one Array Channel block to map the same PLC memory area results in only one of the Array Channel blocks being updated with RBE data.

Allen-Bradley Interface Appendix A
 Array Channel Block Configuration for Allen-Bradley Interface

Function	PLC-2	PLC-3	PLC-5
Data Read by SIM from PLC (All Data Types)	Basic Command Set: "Unprotected Read" CMD: 01 FNC: N/A	Specific command "Word Range Read" CMD:0F FNC: 01	Specific command "Word Range Read" CMD:0F FNC: 01
Data Write by SIM to PLC (Flag Data Type)	Basic Command Set: "Unprotected Bit Write" CMD: 05 FNC: N/A	Specific command "Bit Write" CMD:0F FNC: 02	Specific command "Read-Modify-Write" CMD:0F FNC: 26
Data Write by SIM to PLC (Other Data Types)	Basic Command Set: "Unprotected Write" CMD: 08 FNC: N/A	Specific command "Word Range Write" CMD:0F FNC: 00	Specific command "Word Range Write" CMD:0F FNC: 00
Data Write by PLC to SIM (RBE) (All Data Types)	Basic Command Set: "Unprotected Write" CMD: 08 FNC: N/A	Specific command "Word Range Write" CMD:0F FNC: 00	Specific command "Typed Write" * CMD:0F FNC: 67
* These functions must use the Logical Binary Addressing format or the RBE message is rejected by the SIM. Other formats including PLC-3 Symbolic and PLC-5 Logical ASCII will be rejected.			

Performance considerations



ATTENTION

- Since the Serial Interface I/O Module (SIM) bandwidth is limited, the Array Channel blocks only process writes which change the current process value. This eliminates unnecessary repeated writes.
 - In Experion systems with redundant Controller configurations, the writes are not guaranteed during a failover. The store attempt may occur in the Primary Controller, but it may not reach the SIM before the failover occurs. The Secondary Controller does not attempt to resend the data.
-

An active SIM function block processes the following actions once per its publication period of 250 milliseconds. The publication rate is the same whether the SIM block is assigned to a 5ms-CEE or a 50ms-CEE type.

- Load Serial Interface Array Channel block configurations to the SIM.
- Send Array Channel block write requests to the SIM.
- Monitor status of the SIM, and report diagnostics, as applicable.

Of course, these actions are not performed when the SIM block is inactive. When the SIM block is inactive, the Array Channel blocks set their data to applicable default values.

The SIM block collects the writes for each array channel and sends them to the SIM every 250ms. The following table lists the maximum number writes a SIM block supports per channel in every 250ms cycle. If the SIM block's write list becomes full, it rejects a write to the array channel block.

Array Channel Block	Maximum Number of Writes (Channel/250ms)
SINUMARRCH	8
SIFLAGARRCH	16
SITEXTARRCH (STRLEN = 8)	8
SITEXTARRCH (STRLEN = 16)	4
SITEXTARRCH (STRLEN = 32)	2
SITEXTARRCH (STRLEN = 64)	1

Writes to Array Channel Blocks can also be rejected because the SIM is not keeping up with the writes being sent by the SIM block. Write overruns are indicated by the SIM block FTAAOVRNFL and FTABOVRNFL parameters. To provide an overrun condition alarm, connect the overrun parameters to a FLAG function block configured to generate an OffNormal alarm.

For an Allen-Bradley interface, all configured Array Channel blocks scan the PLC devices in a circular sequence at the specified scan rate with the read data requests. A write data request preempts the read requests (and/or response to any RBE requests). The number of consecutive write data requests is limited to eight (8), after which a Report by Exception request or scan read request is serviced. If outputs, RBE requests, and scan read requests are stacked continuously, the RBE requests and scan read requests are alternately serviced after every eight outputs. This slows data acquisition considerably.

Channels with a scan frequency of 3 to 255 seconds are scanned once upon block activation and then at the configured scan rate. RBE messages reset the scan interval timer, therefore frequent RBE messages can prevent unnecessary scanning.

There is a limit to the number of write requests per second that can be serviced before read response is significantly affected. Because of the time ladder logic takes to execute the maximum number of write requests per second to a PLC running ladder logic should be limited even further. Your Honeywell representative can provide test data and reports on PLC modules certified to date.

Array Channel block execution state

The Array Channel block uses the Execution State (EXECSTATE) and Execution Period (PERIOD) parameter settings for the Control Module that contains it. When the Control Module is activated, the Array Channel block sends its configuration to the SIM function block for loading in the SIM/FTA. Inactivating and activating the Control Module/Array Channel block, reloads the configuration.



CAUTION

It may take a few seconds after the Array Channel block is activated for the configuration to be loaded to the SIM/FTA and good data to be imaged from the device to the Array Channel block. During this time, short duration BADPV alarms may occur on blocks that are accessing the channel's array data.

Write processing considerations

The Array Channel block array data can be written to either through a one-time store from a Sequential Control Module, an operator, or continually through a wired connection.

Upon receiving a store request, the Array Channel block forwards the requested store to the SIM block. The SIM block forwards the store request to the SIM and FTA. The stored value is not saved in the Array Channel block. The Array Channel block value does not change until the imaged value shows the new value, indicating that the store really made it to the end device.



ATTENTION

We recommend using a read-back check to verify that a write is successful in reaching the external device. A read-back check reads the parameter just written and compares it to the value written. When the compared values are equal, it guarantees that the write was successful all the way to the serial device. The feedback time varies based on SIM, FTA, and device performance.

Diagnostic procedures and data configuration

Diagnostic data is stored as single or double bytes of information in the Allen-Bradley Highway module. The various PLC modules hold diagnostic information in different forms and in different RAM locations. This data is referred to as the Diagnostic Counters.

The Allen-Bradley diagnostic commands supported by the procedures that follow are:

Diagnostic Status

Diagnostic Read

Diagnostic Counters Reset

Only modules whose diagnostic information address is returned as a reply to a Diagnostic Status Command in the seventh and eighth bytes are supported (PLC-5 returns 0). This address is added to the value specified in the STARTINDEX as an offset, and a Diagnostic Read collects data into the SIM. Therefore, you do not need to know the starting address for diagnostic data.

Because of differences between modules, you must be familiar with the equipment to properly configure an Array Channel block for diagnostic purposes. It is also up to you to

interpret the diagnostic data returned. The software automatically reformats data from diagnostic counters for easier interpretation.

You can cause a Diagnostic Counters Reset by executing a write to any element of the diagnostic array counters. Note that a write to any one diagnostic counter resets all the diagnostic counters in the module.

Use the settings in the following table to configure a Numeric Array Channel block to acquire diagnostic information from an Allen-Bradley KE/KF Computer Interface Module (CIM). Numeric data is used for diagnostic counters.

Parameter	Setting for Diagnostic Data
DEVADDR	The node address (specified in octal)
AUXDATA[4]	0 (indicates CIM)
AUXDATA[5]	-1 (indicates diagnostic counter)
AUXDATA[6]	11 for up to 32 values of 2-byte data 7 for up to 32 values of 2-byte data 20 for up to 64 values of single-byte data
AUXDATA[7]	Scan frequency
STARTINDEX	Offset into Allen-Bradley Diagnostic Table *
NNUMERIC	Number of diagnostic words/bytes
* You must know which CIM is used because each model can have different meanings for its offset values.	

Use the settings in the following table to configure a Numeric Array Channel block to acquire diagnostic information from an Allen-Bradley PLC. Numeric data is used for diagnostic counters.

Allen-Bradley Interface Appendix A
 Array Channel Block Configuration for Allen-Bradley Interface

Parameter	Setting for Diagnostic Data
DEVADDR	The node address (specified in octal)
AUXDATA[4]	2, 3, or 5 (indicates PLC type)
AUXDATA[5]	-1 (indicates diagnostic counter)
AUXDATA[6]	11 for up to 32 values of 2-byte data 7 for up to 32 values of 2-byte data 20 for up to 64 values of single-byte data
AUXDATA[7]	Scan frequency
STARTINDEX	Offset into Allen-Bradley Diagnostic Table *
NNUMERIC	Number of diagnostic words/bytes
* You must know which PLC model is used because each model can have different meanings for its offset values.	

Use the settings in the following table to configure a Text Array Channel block to set up a diagnostic loop. A repetitive diagnostic loop can be set up to check the integrity of transmissions over the communications link. It works by transmitting a message of a certain length from the FTA which causes the A-B device to reply by transmitting the same data back to the FTA. String data is used for this purpose.

Parameter	Setting for Diagnostic Data
DEVADDR	The node address (specified in octal)
AUXDATA[4]	NaN
AUXDATA[5]	-3
AUXDATA[6]	NaN
AUXDATA[7]	Scan frequency (but not 256)
STARTINDEX	1
STRLEN	64 characters
NSTRING	1

Counters check the attempted/successful transactions and when the block is active, monitor data block.str[1] should contain the message:

Loopback Test: Attempted - xxxxx Pass - xxxxx

Where xxxxx is a pass/failure count.

Any communication errors are displayed, but the BADPVFL is not set for a diagnostic loop.

Note that the loopback test can run along with other Array Channel block scans, but doing so adversely affects performance.

Time-Out gate configuration

The time-out gate feature checks for communication between the FTA and the Allen-Bradley device. This lets the PLC know that the Serial Interface is working.

By configuring an Array Channel block for a periodic write (such as every 10, 20 or 30 seconds), the PLC issues a Report by Exception message. This causes the FTA to return a status message that the ladder logic can monitor and react to.

If the FTA fails, the PLC receives a status code 20_{16} and/or a timeout occurs indicating to the PLC that the host is not communicating. When the FTA recovers, the condition clears and the normal 00 status (message was successful) returns.

Status and error checking

Several Array Channel block and SIM block parameters provide status reporting. Error information appears in the form of a detailed code or status flag. If configured, Error information appears on the Array Channel block in the Monitoring tab in Control Builder (CB) or the Channel and SIM block detail displays. You should periodically check these block parameters.

BADPVFL/ERRFL: Provides overall status of array data (ON = bad). The overall status is bad when there are communication problems or the SIM block is inactive.

INITREQ: Tied to ERRFL status. It always equals the status of the ERRFL. This parameter is provided for the sake of consistency with other function blocks to indicate if the block can be stored to at the current time.

ERRCODE: When ERRFL is ON, provides a detailed 8-character string. Refer to the Notifications Reference and the following Error Messages section for more information.

Error messages

The following table lists some possible Serial Interface and Allen-Bradley communication errors for reference. You may also need to refer to the Allen-Bradley documentation for error messages specific to the PLC.

ERRCODE String	Description
Serial Interface Error Codes	
# ELEMNT	Number of elements is out of range for the given Array Channel block.
ARR INIT	Array Channel block is configured, but no valid data has been received.
AUXMATCH	AUXDATA[2] and AUXDATA[3] configuration settings do not match the other channels in the FTA. All channels must agree.
BAUD/PAR	The Baud Rate/Parity setting in AUXDATA[3] is not a valid setting.
CEE Idle	The CEE is Idle, so the function blocks are executing.
CFG LOAD	SIM is loading configuration to FTA.
ChCfgErr	Array Channel block configuration error exists. Check block configuration carefully.
Ch Inctv	Control Module containing the Array Channel block is inactive.
CONFIG	Can not load configuration to the SIM. Check all configuration data carefully.
DataCond	Array Channel block does not understand Data Conditioner (internal value) sent by the FTA.
DataType	Array Channel block is not supported or out of range for this device.
DEV ADDR	Configured device address is out of range.
Fac Test	A factory test diagnostic is in progress.
FTA COMM	SIM can not communicate with the FTA.
Inv Resp	An invalid field device response has occurred.
IO Comm	There is an I/O communications problem between the CPM and the SIM.

Allen-Bradley Interface Appendix A
Array Channel Block Configuration for Allen-Bradley Interface

ERRCODE String	Description
KPA ADDR	Keep Alive coil address in out of range.
MAX CONF	“Catch All” configuration error.
Md Inctv	The SIM function block is inactive, so the Array Channel block can not get new array data.
NO CONF	No configuration (Channel is not viewable at the operator Station).
No Conn	The Array Channel block can not get data because a proper connection does not exist between the CPM and the SIM.
No Data	Transient condition that occurs when the Control Module containing the Array Channel block is activated. Condition clears once ERRFL is set OFF or ON.
No SIMFB	Array Channel block can not locate its assigned SIM block. Be sure the SIM block is loaded to the CEE.
PLC TYPE	PLC type is not supported.
POL FREQ	Polling frequency is out of range.
SIG/MOD	AUXDATA[2] setting is not valid.
Startidx	The STARTINDEX address is out of range.
STR LEN	Illegal string length for diagnostic loop channel type.
TMOT VAL	Message timeout value is out of range.
Allen-Bradley Communication Error Codes	
ABEXT_mm	Allen-Bradley remote station specific EXT STS error (refer to Allen-Bradley documentation).
ABSTS_nn	Allen-Bradley local/remote station specific STS error (refer to Allen-Bradley documentation)
ACKTMOUT	Timed out waiting for ACK from CIM device.
ARR INIT	Point configured, but no valid data received yet.
CHECKSUM	Incorrect BCC detected on the last received message.
CIM_NAK	Received a NAK from the CIM device.

Allen-Bradley Interface Appendix A
Array Channel Block Configuration for Allen-Bradley Interface

ERRCODE String	Description
INV_RESP	Invalid response received from the Allen-Bradley device.
MAXMSGST	“Catch all” Serial Interface error.
MSGTMOUT	Timed out waiting for the Allen-Bradley device to reply to the last request.
OK_POLL	No errors exist against the Array Channel block whose poll rate is within 0 to 255.
OK_RBE	No errors exist against the Array Channel block whose poll rate is 256.
PARITY	Incorrect parity on at least one character in the last received message.
RBE_FULL	RBE buffer full due to too many Report by Exception requests from the PLC devices.

Special FTA to KE/KF cabling considerations

As previously mentioned, an Allen-Bradley KE/KF Computer Interface Module (CIM) is usually used to communicate with an A-B FTA. The recommended KE/KF CIM configuration is full duplex, even parity, BCC, embedded response disabled, 19,200 baud, and diagnostic pass-through. A special cable with 25-pin (male) to 15-pin (male) connectors and wired as shown below is required to connect the KE/KF CIM to the A-B FTA.

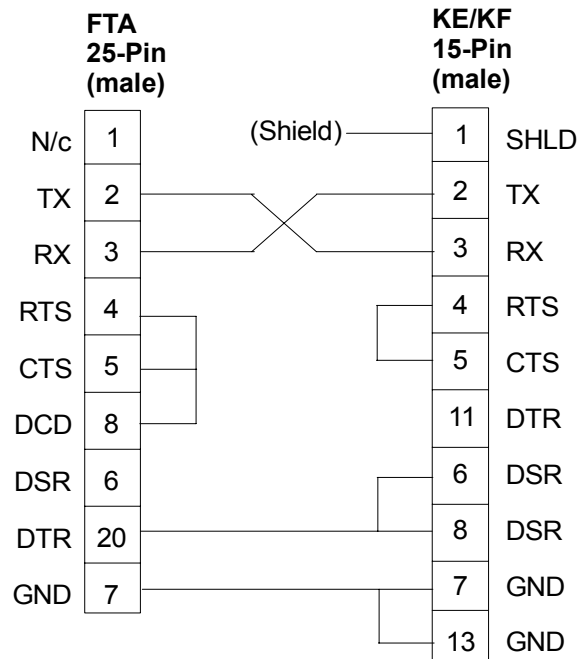

FTA direct to PLC-5 RS-232 Port cable considerations

To make a direct connection between the FTA and a PLC-5, you must configure the PLC-5 serial port as RS-232, full duplex, even parity, 19,200 baud, and diagnostic pass through, ignore duplicate messages. Do **not** configure the port as RS-422 or RS-485. You will need a null modem cable with 25-pin male connections to connect the PLC-5 to the A-B FTA. The cable connections are shown below for reference.

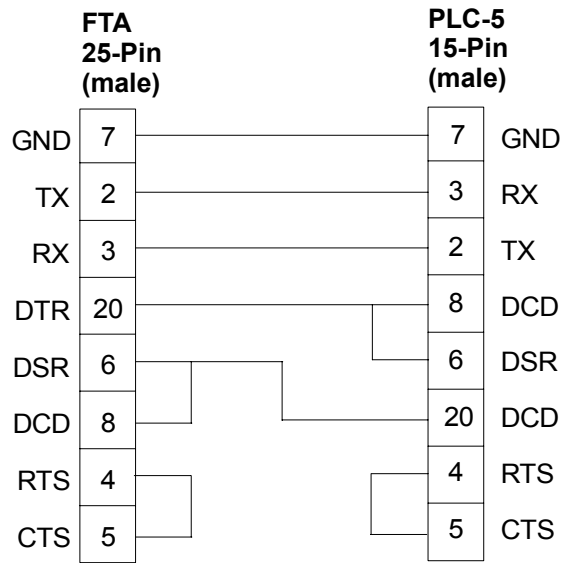

Reference Specifications

The following table lists some general specifications relevant to the Serial Interface function.

Function	Description
Serial Interface Array Channel	
FTA Channel Capacity	Up to 16 channels per SI FTA
SIM Channel Capacity	Up to 32 channels per SIM (2 FTAs)
Data capacity per Array Channel (contiguous data in PLC)	512 Flags (Boolean/coils), or 64 Numerics (8-Bit integers), or 32 Numerics (integers), or 16 Numerics (reals), or 1 string of 64 characters, or 2 string of 32 characters, or 4 string of 16 characters, or 8 string of 8 characters
Reads per Port *	Up to 2048 Booleans/second, or Up to 128 integers/second, or Up to 64 reals/second, or Up to 4, 64-character strings/second, or Weighted combinations of the above
Writes per Port *	10 channels/second
* Read and write performance is sensitive to a number of variables, including the PLC type, scan time, PLC network configuration and traffic, amount of data access from other devices, and the overall health of the PLC network. For best results, a direct PLC connection is recommended. The ratings listed do not represent best performance figures. Read performance degrades with increased writes.	
Allen-Bradley Serial Interface	
<i>Model Numbers</i>	
A-B SI FTA	MU-TSIA12
SIM	TC-MUX021
SIM FTA Power Adapter	TC-SMPD01 (24 Vdc, 18-36 Vdc, 0.4A maximum) TC-SMPC01 (85 to 265 Vac, 47-63 Hz, 12W maximum)

Allen-Bradley Interface Appendix A
 Array Channel Block Configuration for Allen-Bradley Interface

Function	Description
<i>General</i>	
Interface Type	EIA-RS232-D
Number of Serial Ports	2 per SIM, 1 per FTA
Power Adapter to FTA Distance	300 meters (984 feet)
Baud Rate	19,200 baud
Serial Data Format	8 data Bits with even parity
Common Mode Operation	250 Vrms (continuous)
ESD Protection	IEEE SWC 472-1974
<i>EIA-RS232-D Support</i>	
Interface Type	Serial asynchronous
Lines Supported	TXD, RXD, Logic GND, Protectiv GND (Compatible with CCIT V.24; CCIT V.28)
FTA to Device Distance	15 meters (49 feet)
<i>Allen-Bradley Specific</i>	
Protocol	Full duplex Allen-Bradley DF1 with embedded responses
Transmission Mode	Character oriented
Serial Line Mode	RS232
Parity	Even
Number of Stop Bits	1
Modem Control Support	Off
ACK Timeout	3.2 seconds
FTA Message Response Timeout	4.0 seconds
Data Format Supported	Booleans, Reals, Signed/Unsigned Integers, ASCII Strings

Allen-Bradley Interface Appendix A
Array Channel Block Configuration for Allen-Bradley Interface

Function	Description
CIM Communications Options	Pass-through diagnostic requests Ignore handshaking Accept duplicate message BCC error check
PLC Types Supported	PLC-2 PLC-3 (Native Mode and PLC-2 Mode) PLC-5, except PLC-5/20 (Native Mode and PLC-2 Mode)

Allen-Bradley Interface Appendix A
Array Channel Block Configuration for Allen-Bradley Interface

MODBUS Interface Appendix B

Array Channel Block Configuration for Generic MODBUS Interface

About Generic Modbus interface

Many devices that use the AEG Modicon Modbus RTU protocol can communicate with the Experion system through the Array Channel blocks for the SIM. Refer to Modbus documentation for a description of the Modbus protocol.

AUXDATA parameter configuration

The following table summarizes the AUXDATA parameter configuration that defines Serial Interface Array Channel block communications with the Generic Modbus.



ATTENTION

When the AUXDATA[0...7] parameters are not being used with a Generic Modbus interface, they should be set to the default value of NaN (Not a Number).

Parameter	Function	Description
AUXDATA[0]	Specifies the Keep Alive Address for a Modbus coil.	This parameter tells the Modbus system that the Experion subsystem is functioning. It can be configured separately on each array channel block, but no two array channel blocks should write to the same coil. The coil address must be within the range 00001 to 09999. Note: When this parameter is NaN, the Keep Alive function is inactive. If you want to check the Keep Alive coil, you must program the Modbus device to do so.
AUXDATA[1]	Specifies the time interval in seconds to wait before attempting a message retry.	If a valid response is not received after three tries (original plus two retries), a MSGTMOUT error results. The range is 0.25 to 5 seconds on NaN. If NaN is specified, the default timeout is 1.5 seconds. A timeout value can be configured separately for each array channel block.

MODBUS Interface Appendix B

Array Channel Block Configuration for Generic MODBUS Interface

Parameter	Function	Description
AUXDATA[2]	<p>Specifies the signaling protocol and modem control in an integer/decimal format:</p> <p>mmm.n</p> <p>Where mmm is the signaling protocol and n is the modem control (0 = OFF and 1 = ON).</p> <p>For example, 232.1 indicates EIA-232 with modem control ON. The other choices are 232.0 and 485.0. EIA-232 permits use of an external modem.</p>	<p>The first valid array channel block loaded to the Controller with values in AUXDATA[2] and AUXDATA[3] sets the mode and baud rate for the FTA communications. This means that AUXDATA[2] AUXDATA[3] must contain the same value for all array blocks configured through the same FTA. If array blocks loaded later to that FTA have different AUXDATA[2]/[3] values, an AUXMATCH error results.</p> <p>The modem control feature switches the following signals: RTS, CTS, DSR, DTR, and DCD. When AUXDATA[2] is NaN, the protocol is EIA-232 and modem control is OFF.</p>
AUXDATA[3]	<p>Specifies the baud rate in an integer/decimal format:</p> <p>bbbb.n</p> <p>Where bbbb is the baud rate and n is the parity (0 = None, 1 = Odd, 2 = Even).</p>	<p>The legal baud rates are 19200, 9600, 4800, 2400, and 1200. NaN (dashes) results in a default value of 19200 baud with odd parity.</p>
AUXDATA[4] to AUXDATA[7]	<p>These parameters are not applicable to a Generic Modbus interface.</p>	<p>Set these parameters to NaN when communicating with a Modbus.</p>

STARTINDEX and number of elements parameters configuration

The value configured for the STARTINDEX parameter in a given Array Channel block determines the Modbus Start Index and function. Only one type of external data can be accessed per Array Channel block.

The number of elements parameter (NFLAG, NNUMERIC, or NSTRING) in a Flag Array, Numeric Array, or Text Array Channel block determines the number of flags, numerics, or strings in a given data array.

The following table shows the relationship between Modbus functions and the STARTINDEX and number of elements parameters. The Start Index Ranges defines the Modbus address map. The most significant digit in this column identifies the Modbus function (for example, read coil status). The lower four digits define the starting address to access data for the given Modbus function. The address ranges 2xxxx, 4xxxx, 5xxxx, 7xxxx, 8xxxx, and 9xxxx all address the same xxxx registers in the PLC, but with different data formats. When multiple numeric data types are used, you must configure the STARTINDEX for each array to avoid overlapping arrays.

The maximum number of elements specifies the maximum number of flags, numerics, or strings that can be configured for a given Start Index Range and block type. All of the specified elements are read in a single transaction.

Start Index Ranges	Modbus Function	Read FC	Array Channel Function Block	Data Range	Max. No. Elem.
		Write FC			
00001 - 09999	Read Coil Status	01	SIFLAGARRCH Read/Write Bit Flags	ON/OFF	512
	Force Single Coil	05			
10001 – 19999	Read Input Status	02	SIFLAGARRCH Read Only Bit Flags	ON/OFF	512
	Not Applicable	N/A			
20001 – 29999 *	Read Holding Registers	03	SINUMARRCH Word Swapped IEEE FI.Pt Read/Write	-34E38 to 34E38	16
	Preset Multiple Registers	16 * *			
30001 – 39999	Read Input Registers	04	SINUMARRCH Signed Integer Words Read only	-32768 to 32767	32
	Not Applicable	N/A			

MODBUS Interface Appendix B

Array Channel Block Configuration for Generic MODBUS Interface

Start Index Ranges	Modbus Function	Read FC	Array Channel Function Block	Data Range	Max. No. Elem.
		Write FC			
40001 – 49999	Read Holding Registers	03	SINUMARRCH Signed Integer Array Read/Write	-32768 to 32767	32
	Preset Single Register	06			
50001 – 59999 *	Read Holding Registers	03	SITEXTARRCH ASCII Encoded Bytes Read/Write	Printable Characters	8 of 8 4 or 16 2 or 32 1 of 64
	Preset Single Register	06			
60000 *	Loopback Diagnostics	08	SITEXTARRCH Loopback Test	None	1 of 64
70001 – 79999	Read Holding Registers	03	SINUMARRCH IEEE Floating Point Read/Write	-34E38 to 34E38	16
	Preset Multiple Registers	16 * *			
80002 – 89999 *	Read Holding Registers	03	SINUMARRCH IEEE Fl. Pt in Addr- 1 Read/Write	-34E38 to 34E38	16
	Preset Multiple Registers	16 * *			
90001 – 99999	Read Holding Registers	03	SINUMARRCH Unsigned Integer Words Read/Write	0 to 65535	32
	Preset Single Register	06			
<p>* These ranges are extensions to the Modbus protocol specifications to support certain Modbus devices.</p> <p>* * Function Code 16 is used to write a multiword data type in one transaction.</p>					

Modbus loopback diagnostic

The loopback test consists of sending a test message to the Modbus device and waiting for the proper response. To do this, configure a TEXT array channel block as follows.

- STARTINDEX = 60000 (loopback test address)
- NSTRING = 1
- STRLEN = 64

When the block is active, the monitor data block.str[1] should contain the message:

Loopback Test: Attempted – xxxxx Pass – xxxxx

Where xxxxx is a pass/failure count.

(Note that the loopback test can run along with other Array Channel block scans, but doing so adversely affects performance.)

Performance considerations



ATTENTION

- Since the Serial Interface I/O Module (SIM) bandwidth is limited, the Array Channel blocks only process writes which change the current process value. This eliminates unnecessary repeated writes.
 - In Experion systems with redundant Controller configurations, the writes are not guaranteed during a failover. The store attempt may occur in the Primary Controller, but it may not reach the SIM before the failover occurs. The Secondary Controller does not attempt to resend the data.
-

An active SIM function block processes the following actions once per its publication period of 250 milliseconds. The publication rate is the same whether the SIM block is assigned to a 5ms-CEE or a 50ms-CEE type.

- Load Serial Interface Array Channel block configurations to the SIM.
- Send Array Channel block write requests to the SIM.
- Monitor status of the SIM, and report diagnostics, as applicable.

MODBUS Interface Appendix B

Array Channel Block Configuration for Generic MODBUS Interface

Of course, these actions are not performed when the SIM block is inactive. When the SIM block is inactive, the Array Channel blocks set their data to applicable default values.

The SIM block collects the writes for each array channel and sends them to the SIM every 250ms. The following table lists the maximum number writes a SIM block supports per channel in every 250ms cycle. If the SIM block's write list becomes full, it rejects a write to the array channel block.

Array Channel Block	Maximum Number of Writes (Channel/250ms)
SINUMARRCH	8
SIFLAGARRCH	16
SITEXTARRCH (STRLEN = 8)	8
SITEXTARRCH (STRLEN = 16)	4
SITEXTARRCH (STRLEN = 32)	2
SITEXTARRCH (STRLEN = 64)	1

Writes to Array Channel Blocks can also be rejected because the SIM is not keeping up with the writes being sent by the SIM block. Write overruns are indicated by the SIM block FTAAOVRNFL and FTABOVRNFL parameters. To provide an overrun condition alarm, connect the overrun parameters to a FLAG function block configured to generate an OffNormal alarm.

Array Channel block execution state

The Array Channel block uses the Execution State (EXECSTATE) and Execution Period (PERIOD) parameter settings for the Control Module that contains it. When the Control Module is activated, the Array Channel block sends its configuration to the SIM function block for loading in the SIM/FTA. Inactivating and activating the Control Module/Array Channel block, reloads the configuration.



CAUTION

It may take a few seconds after the Array Channel block is activated for the configuration to be loaded to the SIM/FTA and good data to be imaged from the device to the Array Channel block. During this time, short duration BADPV alarms may occur on blocks that are accessing the channel's array data.

Write processing considerations

The Array Channel block array data can be written to either through a one-time store from a Sequential Control Module, an operator, or continually through a wired connection.

Upon receiving a store request, the Array Channel block forwards the requested store to the SIM block. The SIM block forwards the store request to the SIM and FTA. The stored value is not saved in the Array Channel block. The Array Channel block value does not change until the imaged value shows the new value, indicating that the store really made it to the end device.



ATTENTION

We recommend using a read-back check to verify that a write is successful in reaching the external device. A read-back check reads the parameter just written and compares it to the value written. When the compared values are equal, it guarantees that the write was successful all the way to the serial device. The feedback time varies based on SIM, FTA, and device performance.

Status and error checking

Several Array Channel block and SIM block parameters provide status reporting. Error information appears in the form of a detailed code or status flag. If configured, Error information appears on the Array Channel block in the Monitoring tab in Control Builder (CB) or the Channel and SIM block detail displays. You should periodically check these block parameters.

BADPVFL/ERRFL: Provides overall status of array data (ON = bad). The overall status is bad when there are communication problems or the SIM block is inactive.

INITREQ: Tied to ERRFL status. It always equals the status of the ERRFL. This parameter is provided for the sake of consistency with other function blocks to indicate if the block can be stored to at the current time.

ERRCODE: When ERRFL is ON, provides a detailed 8-character string. Refer to the Notifications Reference and the following Error Messages section for more information.

MODBUS Interface Appendix B

Array Channel Block Configuration for Generic MODBUS Interface

Error messages

The following table lists some possible Serial Interface and Modbus communication errors for reference. You may also need to refer to the Modbus documentation for error messages specific to the serial device.

ERRCODE String	Description
Serial Interface Error Codes	
# ELEMNT	Number of elements is out of range for the given Array Channel block.
ARR INIT	Array Channel block is configured, but no valid data has been received.
AUXMATCH	AUXDATA[2] and AUXDATA[3] configuration settings do not match the other channels in the FTA. All channels must agree.
BAUD/PAR	The Baud Rate/Parity setting in AUXDATA[3] is not a valid setting.
CEE Idle	The CEE is Idle, so the function blocks are executing.
CFG LOAD	SIM is loading configuration to FTA.
ChCfgErr	Array Channel block configuration error exists. Check block configuration carefully.
Ch Inctv	Control Module containing the Array Channel block is inactive.
CONFIG	Can not load configuration to the SIM. Check all configuration data carefully.
DataCond	Array Channel block does not understand Data Conditioner (internal value) sent by the FTA.
DataType	Array Channel block is not supported or out of range for this device.
DEV ADDR	Configured device address is out of range.
Fac Test	A factory test diagnostic is in progress.
FTA COMM	SIM can not communicate with the FTA.
Inv Resp	An invalid field device response has occurred.
IO Comm	There is an I/O communications problem between the CPM and the SIM.

MODBUS Interface Appendix B

Array Channel Block Configuration for Generic MODBUS Interface

ERRCODE String	Description
KPA ADDR	Keep Alive coil address in out of range.
MAX CONF	“Catch All” configuration error.
Md Inctv	The SIM function block is inactive, so the Array Channel block can not get new array data.
NO CONF	No configuration (Channel is not viewable at the operator Station).
No Conn	The Array Channel block can not get data because a proper connection does not exist between the CPM and the SIM.
No Data	Transient condition that occurs when the Control Module containing the Array Channel block is activated. Condition clears once ERRFL is set OFF or ON.
No SIMFB	Array Channel block can not locate its assigned SIM block. Be sure the SIM block is loaded to the CEE.
PLC TYPE	PLC type is not supported.
POL FREQ	Polling frequency is out of range.
SIG/MOD	AUXDATA[2] setting is not valid.
Startidx	The STARTINDEX address is out of range.
STR LEN	Illegal string length for diagnostic loop channel type.
TMOT VAL	Message timeout value is out of range.
Modbus Communication Error Codes	
CHECKSUM	Incorrect checksum received.
Ex or xx	Modbus device error codes (Hex). Refer to device documentation.
NO CTS	Modem did not respond with Clear To Send within the message timeout time.
NO DSR	Modem is not asserting Data Set Ready as expected.
Parity Checksum MSGTMOUT ChrTmout	A Modbus device communication error has occurred.

MODBUS Interface Appendix B

Array Channel Block Configuration for Generic MODBUS Interface

ERRCODE String	Description
RX OVFL0	A receive buffer overflow occurred on a message response received from the Modbus device.

Special Modbus slave FTA implementation

The following table summarizes the tasks and information associated with implementing a Modbus Slave FTA. The Modbus Slave FTA is available as a repeatable special product (hardware part number 51191029-Tab, documentation part number 51191030).

Task/Information	Action/Reference
Restrictions	<ul style="list-style-type: none">• Must pair only one Master and one Slave.• Since the Slave responds to all addresses, no other multidrop devices are permitted.• To avoid the Ex-2 error, configure and load the Slave FTA first.• You can configure different device addresses for each Array Channel pair, but only addresses 1 to 15 are legal.

Task/Information	Action/Reference
Configuration	<ul style="list-style-type: none"> • In each Master and Slave Array Channel pair, configure the identical settings for the device address (DEVADDR) and start index (STARTINDEX) parameters. • Configure identical, non-overlapping data areas in Master and Slave Array Channel pairs. For example, if Array 1 is 32 integers with a STARTINDEX of 90001, then Array 2 must have a STARTINDEX of 00033. If Array 1 is 512 Booleans with a STARTINDEX of 00000 and Array 2 is 16 floating points, then Array 2 must have a STARTINDEX of 70513 and Array 3 must have a STARTINDEX of $x00001 + 512 + 16 = 529$. • In all Slave Array Channels, set AUXDATA[4] parameter to a non-zero value (1.0) to enable the Remote Terminal Unit (RTU) protocol. • In all Master Array Channels, set AUXDATA[1] parameter to recommended 3.0 second timeout. • In all Master and Slave Array Channel pairs, configure the identical settings for AUXDATA[2] and AUXDATA[3] parameters. <ul style="list-style-type: none"> – For short distances, the default is RS-232 direct connection with NaN settings for both AUXDATA[2] and AUXDATA[3] parameters. – For long distance, use RS485 connection with a 485.0 setting for the AUXDATA[2] parameter and a 19200.1 setting for the AUXDATA[3] parameter.
Common Errors	<ul style="list-style-type: none"> • If the Master accesses a device address that does not match an existing Slave Array configuration, the Slave responds with an Ex-2 error and freezes. After the Master address is corrected, you must restart or reconfigure the Slave. • If the Slave Array is configured with overlapping data areas between arrays, it returns the STRTINDX error code. • If the Slave Array is configured with a conflicting device address, it returns the DEV ADDR error code. • If the Slave is configured for a STARTINDEX address of 8xxxx, it causes an Ex-2 error code in the Master. The 8xxxx address (IEEE Float at address -1) is not supported.

MODBUS Interface Appendix B

Array Channel Block Configuration for Generic MODBUS Interface

Reference Specifications

The following table lists some general specifications relevant to the Serial Interface function.

Function	Description
Serial Interface Array Channel	
FTA Channel Capacity	Up to 16 channels per SI FTA
SIM Channel Capacity	Up to 32 channels per SIM (2 FTAs)
Data capacity per Array Channel (contiguous data in PLC)	512 Flags (Boolean/coils), or 64 Numerics (8-Bit integers), or 32 Numerics (integers), or 16 Numerics (reals), or 1 string of 64 characters, or 2 string of 32 characters, or 4 string of 16 characters, or 8 string of 8 characters
Reads per Port *	Up to 2048 Booleans/second, or Up to 128 integers/second, or Up to 64 reals/second, or Up to 4, 64-character strings/second, or Weighted combinations of the above
Writes per Port *	10 channels/second
* Read and write performance is sensitive to a number of variables, including the PLC type, scan time, PLC network configuration and traffic, amount of data access from other devices, and the overall health of the PLC network. For best results, a direct PLC connection is recommended. The ratings listed do not represent best performance figures. Read performance degrades with increased writes.	
MODBUS Serial Interface	
<i>Model Numbers</i>	
MODBUS SI FTA	MU-TSIM12
SIM	TC-MUX021
SIM FTA Power Adapter	TC-SMPD01 (24 Vdc, 18-36 Vdc, 0.4A maximum) TC-SMPC01 (85 to 265 Vac, 47-63 Hz, 12W maximum)

MODBUS Interface Appendix B

Array Channel Block Configuration for Generic MODBUS Interface

Function	Description
<i>General</i>	
Interface Type	EIA-RS232-D or EIA-485
Number of Serial Ports	2 per SIM, 1 per FTA
Power Adapter to FTA Distance	300 meters (984 feet)
Protocol	Modbus
Transmission Mode	RTU
Serial Line Mode	RS232 or RS485
Selectable Baud Rates	1200, 2400, 4800, 9600, 19200 bps
Serial Data Format	8 data bits with programmable ninth bit (parity)
Selectable Parity	None, odd, or even
Common Mode Operation	250 Vrms (continuous)
ESD Protection	IEEE 801.2
Surge Protection	IEEE SWC 472-1974
Number of Stop Bits	1
Modem Control Support	Selectable On/Off
Keep Alive Cell Write	Configurable address
Message Response Timeout Time	Configurable timeout
Inter-Message Stall Time	3.5 Character Time minimum
Data Formats Supported	Boolean, Real, ASCII Strings, Signed Integers, Unsigned Integers
Exception Errors Reported	Keep Alive, Message Response Timeout, Signaling Mode/Modem Support, Baud Rate, Parity
<i>EIA-RS232-D Support</i>	
Interface Type	Serial asynchronous

MODBUS Interface Appendix B

Array Channel Block Configuration for Generic MODBUS Interface

Function	Description
Lines Supported	TXD, RXD, RTS, CTS, DSR, DTR (Compatible with CCIT V.24; CCIT V.28)
FTA to Device Distance	15 meters (49 feet) (Cable capacitance = 2500 pF maximum.)

EIA-485 Support

Interface Type	Serial asynchronous half duplex only
Lines Supported	Two wire differential pair: DATA+, DATA-, Protective GND (shield)
Number of Transceivers	15 drops maximum
FTA to Device Distance	1.2 Km (4000 ft) maximum