

Honeywell

Experion
Fault Tolerant Ethernet Bridge
Implementation Guide

EP-DCX264

R301.1

11/06

Notices and Trademarks

**Copyright 2006 by Honeywell International Inc.
Release 301.1 November 27, 2006**

While this information is presented in good faith and believed to be accurate, Honeywell disclaims the implied warranties of merchantability and fitness for a particular purpose and makes no express warranties except as may be stated in its written agreement with and for its customers.

In no event is Honeywell liable to anyone for any indirect, special or consequential damages. The information and specifications in this document are subject to change without notice.

Honeywell, PlantScape, Experion, and **TotalPlant** are registered trademarks of Honeywell International Inc.

Other brand or product names are trademarks of their respective owners.

Honeywell International
Process Solutions
2500 West Union Hills
Phoenix, AZ 85027
1-800 343-0228

About This Document

Provides information for implementing a Fault Tolerant Ethernet supervisory network between Experion Servers and C200/C300 Controllers through the Fault Tolerant Ethernet Bridge module. It includes module installation, configuration, operation, and service data.

Release Information

Document Name	Document ID	Release Number	Publication Date
Fault Tolerant Ethernet Bridge Implementation Guide - ftebg	EP-DCX264	301.1	11/06

References

The following list identifies all documents that may be sources of reference for material discussed in this publication.

Document Title

Contacts

World Wide Web

The following Honeywell web sites may be of interest to Process Solutions customers.

Honeywell Organization	WWW Address (URL)
Corporate	http://www.honeywell.com
Honeywell Process Solutions	http://hpsweb.honeywell.com

About This Document

Contacts







Telephone

Contact us by telephone at the numbers listed below.







Location	Organization	Phone
United States and Canada	Honeywell IAC Solution Support Center	1-800-822-7673
Europe	Honeywell TAC-EMEA	+32-2-728-2704
Pacific	Honeywell Global TAC - Pacific	1300-300-4822 (toll free within Australia) +61-8-9362-9559 (outside Australia)
India	Honeywell Global TAC - India	+91-20-2682-2458
Korea	Honeywell Global TAC - Korea	+82-2-799-6317
People's Republic of China	Honeywell Global TAC - China	+86-10-8458-3280 ext. 361
Singapore	Honeywell Global TAC - South East Asia	+65-6580-3500
Taiwan	Honeywell Global TAC - Taiwan	+886-7-323-5900
Japan	Honeywell Global TAC - Japan	+81-3-5440-1303
Elsewhere	Call your nearest Honeywell office.	

Symbol Definitions

The following table lists those symbols used in this document to denote certain conditions.

Symbol	Definition
	ATTENTION: Identifies information that requires special consideration.
	TIP: Identifies advice or hints for the user, often in terms of performing a task.
	REFERENCE -EXTERNAL: Identifies an additional source of information outside of the bookset.
	REFERENCE - INTERNAL: Identifies an additional source of information within the bookset.
CAUTION	Indicates a situation which, if not avoided, may result in equipment or work (data) on the system being damaged or lost, or may result in the inability to properly operate the process.
	CAUTION: Indicates a potentially hazardous situation which, if not avoided, may result in minor or moderate injury. It may also be used to alert against unsafe practices. CAUTION symbol on the equipment refers the user to the product manual for additional information. The symbol appears next to required information in the manual.
	WARNING: Indicates a potentially hazardous situation, which, if not avoided, could result in serious injury or death. WARNING symbol on the equipment refers the user to the product manual for additional information. The symbol appears next to required information in the manual.

About This Document
Symbol Definitions

Symbol	Definition
	WARNING, Risk of electrical shock: Potential shock hazard where HAZARDOUS LIVE voltages greater than 30 Vrms, 42.4 Vpeak, or 60 VDC may be accessible.
	ESD HAZARD: Danger of an electro-static discharge to which equipment may be sensitive. Observe precautions for handling electrostatic sensitive devices.
	Protective Earth (PE) terminal: Provided for connection of the protective earth (green or green/yellow) supply system conductor.
	Functional earth terminal: Used for non-safety purposes such as noise immunity improvement. NOTE: This connection shall be bonded to Protective Earth at the source of supply in accordance with national local electrical code requirements.
	Earth Ground: Functional earth connection. NOTE: This connection shall be bonded to Protective Earth at the source of supply in accordance with national and local electrical code requirements.
	Chassis Ground: Identifies a connection to the chassis or frame of the equipment shall be bonded to Protective Earth at the source of supply in accordance with national and local electrical code requirements.

Contents

INTRODUCTION	1
Overview	1
Abstract	1
Functional Overview and Guidelines	2
Getting Started	5
Locating reference documentation	5
Installing Experion software	5
Installing FTE supervisory network	5
Determining wiring requirements.....	5
Starting point assumptions.....	6
Conventions	7
Terms and type representations.....	7
INSTALLATION	9
FTE Bridge Module	9
Setting unique Device Index.....	9
Checking cable shield ground jumper	11
A word about MAC addresses.....	13
Installing FTE Bridge module (TC-FTEB01/TK-FTEB01).....	13
Attaching FTE cables	16
CONFIGURATION	19
Things to Consider Before Configuring FTE Bridge	19
Address configuration considerations	19
Other configuration considerations.....	22
I/O memory usage considerations.....	24
Configuring FTE Bridge	27
Setting up addresses	27
Checking status of BOOTP server service	27
Creating FTE Bridge module block	29
Loading FTE Bridge block.....	34
OPERATION	37
Starting and Monitoring FTE Bridge Module	37

Contents

Applying power to FTE Bridge Module	37
Monitoring front-panel display	37
Monitoring front-panel LEDs.....	39
Using Control Builder Interface	40
About Monitoring mode	40
Monitoring status through block configuration form	41
Viewing Main tab	42
Viewing UDP/TCP tab	43
Viewing IP/ICMP	46
Viewing FTE tab.....	49
Viewing ICP Bridging tab.....	52
Viewing ICP Statistics tab	53
Viewing Version tab.....	54
Viewing IOMGR Statistics tab	55
Viewing Server History tab	55
Viewing Server Displays tab.....	57
Viewing Control Confirmation tab.....	59
Viewing Identification tab.....	60
Using Network Tools (NTools) Utility	62
About NTools.....	62
Launching NTools in Ethernet mode	62
Using Station Displays.....	64
Viewing Detail or Group displays.....	64
Viewing Event Summary display	64
FTE Bridge Redundancy Operation Considerations	65
About redundancy	65
RM based redundancy	66
Switchover and Secondary readiness	66
Failure conditions and switchover	67
FTE Bridge switchover considerations	68
SERVICE	71
Maintenance considerations	71
Periodic checks	71
About removal and insertion under power	71
Remove and replace FTE Bridge module TC/TK-FTEB01	71
Updating FTE Bridge module firmware	74
Spare parts.....	79
Configuration changes and migration scenarios.....	79
Changing base IP address	79
Changing the Device Index or slot number for a configured FTE Bridge module	80
Upgrading non-redundant chassis to redundant chassis pair.....	82

Migrating from ControlNet or Ethernet supervisory network	84
Migration from FTE based C200 to C300	84
Prerequisites	85
Considerations	85
Checking software and firmware versions.....	85
Exporting current database and restoring clean database	86
Build new C300 controllers.....	87
Configuring control strategy	87
Import/export and on-process migration support	88
Troubleshooting.....	88

Contents

Tables

Tables

Table 1 Viewing FTE Bridge icon in Monitoring tab35
Table 2 Typical FTE Bridge Module Power Up Scenarios37
Table 3 Possible Display Indications.....38
Table 4 Possible LED Indications39
Table 5 FTE Bridge Module Test Codes.....91

Figures

Figure 1 Sample Experion C200 with FTE Supervisory Network Topology3
Figure 2 Sample Experion C300 with Series A - Chassis I/O topology4
Figure 3 8-pin RJ-45 connector pin out..... 16
Figure 4 FTE Bridge module front panel indicators.38
Figure 5 Typical RCP setup in 10-slot chassis.65
Figure 6 Basic C300 with Series A I/O topology84

Introduction

Overview

Abstract

The Experion system supports supervisory level communications over Honeywell's Fault Tolerant Ethernet (FTE) network using the Fault Tolerant Ethernet Bridge module. It also supports supervisory level communications over a ControlNet network or Ethernet network using a ControlNet Interface (CNI) module or Ethernet module, respectively.



ATTENTION

You cannot mix the supervisory network types on an Experion Server or Station. For example, if your Server is currently using a ControlNet supervisory network, you cannot add a Fault Tolerant Ethernet supervisory network to the Server for simultaneous communication with different controllers. Of course, you can replace the ControlNet network with a FTE network, if desired.

Since Fault Tolerant Ethernet technology provides a highly available networking scheme using commercial network interface cards (NIC) and Ethernet switches, the preferred supervisory network type is Fault Tolerant Ethernet.



REFERENCE - INTERNAL

For more information about Honeywell's Fault Tolerant Ethernet, please refer to the *Fault Tolerant Ethernet Overview and Implementation Guide* in Knowledge Builder.

Functional Overview and Guidelines

The following figure shows a basic Experion system topology with C200 Controller using a Fault Tolerant Ethernet supervisory network. The Experion system still provides the same configuration, control, and monitor functions as it does with a ControlNet supervisory network. However, the following guidelines are unique to Fault Tolerant Ethernet supervisory networks.

- Each FTE Bridge module must be assigned a unique **Device Index**.
- The same Experion Server cannot support simultaneous ControlNet or Ethernet and Fault Tolerant Ethernet communications to different C200 Process Controllers (also known as C200 Controllers).
- Must use a downlink ControlNet interface module to support remote I/O over a ControlNet segment.
- The Fault Tolerant Ethernet Bridge module provides 10 megabits per second (Mbps) Ethernet connectivity. All Ethernet switches must be 10/100 Mbps with a minimum 1 gigabits per second fast backplane to minimize latency.

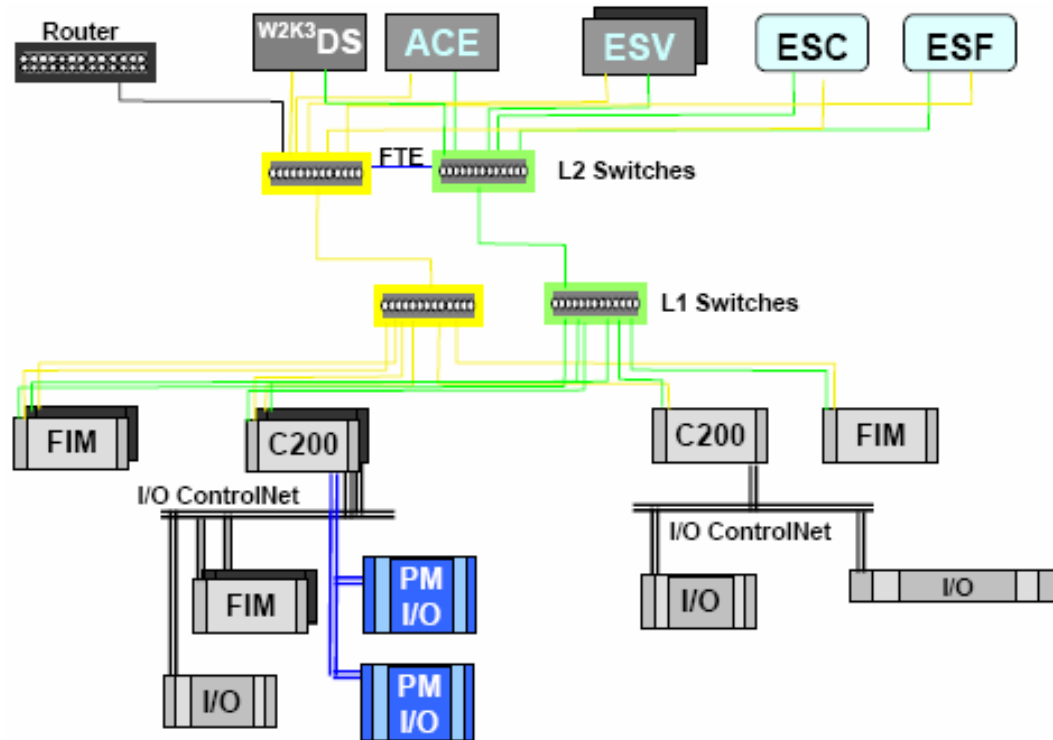

Figure 1 Sample Experion C200 with FTE Supervisory Network Topology

Beginning with Experion R300, the C300 Controller will reside on the same FTE network as the FTE Bridge module and support C300 to C200 peer-to-peer communications. The C300 can communicate directly with Series A - Chassis I/O through a FTE Bridge module mounted in the I/O chassis, as shown in the following figure. A C300 can also communicate with ControlNet resident devices, like Programmable Logic Controllers (PLC), and so on, through a FTE Bridge module mounted in a chassis with a ControlNet Interface module (CNI) or Ethernet module.

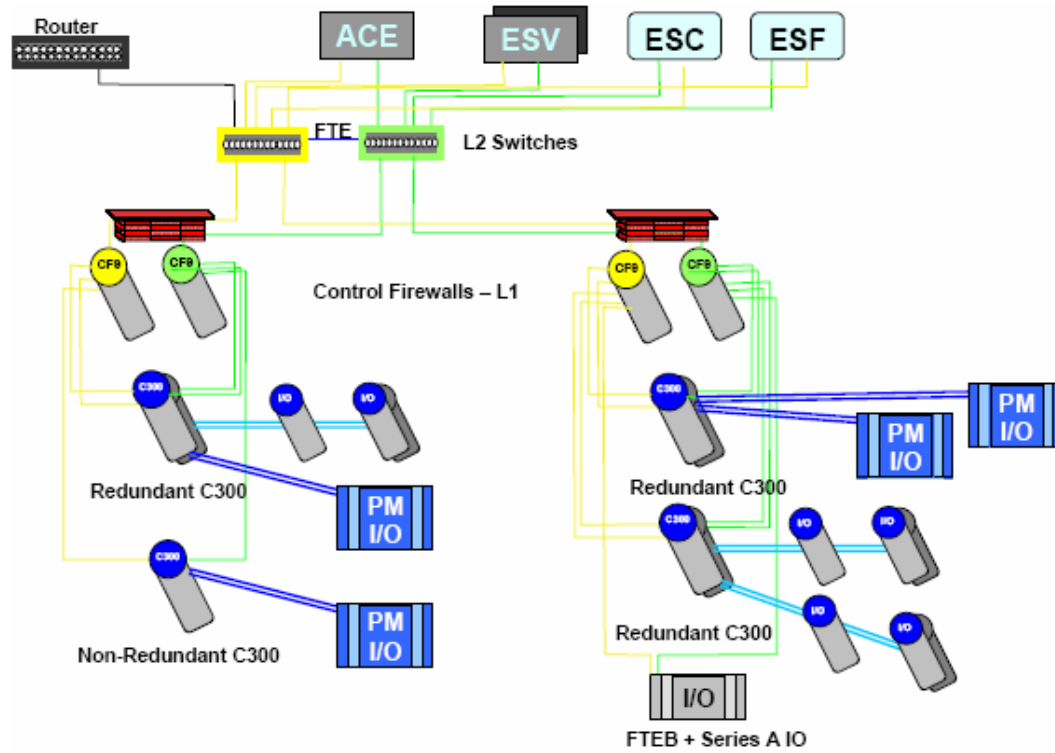

Figure 2 Sample Experion C300 with Series A - Chassis I/O topology

Getting Started

Locating reference documentation

The main source for Experion documentation is the online Knowledge Builder. It is provided on a separate CD with the Experion software. Once this documentation is loaded, you can access Knowledge Builder through the **Help** menu in the Control Builder application or directly through the **Start** menu under the **Performance Support Tools** program.

You should also have the manufacturer's documentation provided with any third-party products.

Installing Experion software



REFERENCE - EXTERNAL

Please refer to the *Software Installation and Upgrade Guide* for details about installing the Experion software. The Fault Tolerant Ethernet Bridge is compatible with Experion software release R200 or greater.

Installing FTE supervisory network



REFERENCE - INTERNAL

Please refer to the:

- *Fault Tolerant Ethernet Installation, and Service Guide* for details about installing Fault Tolerant Ethernet as the supervisory network.
 - *Fault Tolerant Ethernet Overview and Implementation Guide* for general information about implementing a FTE network.
-

Determining wiring requirements

You will need category 5 shielded twisted pair cable with 100 ohm impedance and electrical characteristics supporting transmission rates of up to 100 Mbps to connect the Fault Tolerant Ethernet Bridge and NIC to switch ports. The cable must be compliant with the TIA/EIA-568A wiring standard as well as the 100BaseTX IEE-802.3u specification. Be sure the cable is appropriate for your planned routing method and meets both national and local electrical and fire codes.



REFERENCE - INTERNAL

Refer to the *Fault Tolerant Ethernet (FTE) Specification and Technical Data EP03-500-200* for details about FTE cable usage and available Honeywell pre-configured cables.

If you have access to the Internet, you can visit the Belden Wire and Cable Company web site at <http://www.belden.com/> for helpful technical data on a wide variety of wire and cable types.

Starting point assumptions

We assume that the current software release is running on your Experion Server and all applicable FTE nodes. This includes the FTE driver and the BOOTP Server service.

We assume that you have a working knowledge of Ethernet and the Transmission Control Protocol/Internet Protocol (TCP/IP).



REFERENCE - EXTERNAL

For more information about TCP/IP and internetworking, refer to:

- *Internetworking with TCP/IP – Vol. 1, 2nd ed.*, by Douglas E Comer (ISBN 0-13-216987-8)
 - *The Ethernet Management Guide — Keeping The Link* (ISB 0-07-046320-4)
 - *An Introduction to TCP/IP* (ISBN 3-540-96651-X)
 - *Computer Networks* by Andrew S. Tanenbaum (ISBN 0-13-162959-X)
-

Conventions

Terms and type representations

The following table summarizes the terms and type representation conventions used in this Guide.

Term/Type Representation	Meaning	Example
click	Click left mouse button once. (Assumes cursor is positioned on object or selection.)	Click the Browse button.
double-click	Click left mouse button twice in quick succession. (Assumes cursor is positioned on object or selection.)	Double click the Station icon.
drag	Press and hold the left mouse button while dragging cursor to new screen location and then release the button. (Assumes cursor is positioned on object or selection to be moved.)	Drag the PID function block onto the Control Drawing.
right-click	Click right mouse button once. (Assumes cursor is positioned on object or selection.)	Right-click the AND function block.
<F1>	Keys to be pressed are shown in angle brackets.	Press <F1> to view the online Help.
<Ctrl>+<C>	Keys to be pressed together are shown with a plus sign.	Press <Ctrl>+<C> to close the window.
File->New	Shows menu selection as menu name followed by menu selection	Click File->New to start new drawing.
>D:\setup.exe<	Data to be keyed in at prompt or in an entry field.	Key in this path location >D:\setup.exe<.

Installation

FTE Bridge Module



ATTENTION

Be sure you review the Preinstallation Considerations and approval body notifications included in the *Control Hardware Installation Guide* in Knowledge Builder before you install any Experion system component.



ESD

Electrostatic discharge can damage integrated circuits or semiconductors if you touch backpanel connector pins. Follow these guidelines when you handle a module:

- Touch a grounded object to discharge static potential,
 - Wear an approved wrist-strap grounding device,
 - Do not touch the backpanel connector or connector pins,
 - Do not touch circuit components inside the module,
 - If available, use a static safe workstation,
 - When not in use, keep the module in its static shield box or bag.
-

Setting unique Device Index

Use the following procedure to set a unique **Device Index** for the Fault Tolerant Ethernet Bridge module before it is installed.

Step	Action
1	If applicable, remove the FTE Bridge module from its shipping container.
2	Locate the pair of binary-coded decimal rotary switches on the top of the module.

Installation
FTE Bridge Module

Step	Action
	<p>ATTENTION</p> <p>If the FTE Bridge module is being installed in a redundant chassis pair (RCP), be sure to set the Device Index for the FTE Bridge module to be installed in the Primary chassis to be an odd number. Then, set the Device Index for the FTE Bridge module to be installed in the Secondary chassis to be the next higher even number.</p> <p>For example, if you set the Device Index to 17 for the Primary FTE Bridge module, you would set the Device Index for the Secondary FTE Bridge module to 18.</p>
<p>3</p>	<p>Viewing the top of the switches, use your fingers to set the left-hand switch to the desired most significant decimal number and the right-hand switch to the desired least significant decimal number. The applicable setting range is 01 to 99.</p> <p>For example, to set a Device Index equal to “18”; set the left switch to “1” and right one to “8”.</p> <div data-bbox="548 1035 1218 1711" data-label="Diagram"> <p style="text-align: center;">Device index for this module is 18</p> <p style="text-align: center;">Most significant decimal number Least significant decimal number</p> <p style="transform: rotate(-90deg); position: absolute; left: -100px; top: 50px;">Front of module</p> <p style="text-align: center;">Top of module</p> </div>

Step	Action
4	If applicable, repeat this procedure to set the Device Index for the Secondary FTE Bridge module for a redundant chassis pair configuration.
5	This completes the procedure. Go to the next section.

Checking cable shield ground jumper



ATTENTION

- The shield for the shielded twisted pair cable must be connected to ground at only one end. Be sure the cable shield ground jumper on the FTE Bridge module is positioned correctly to either ground the pair of cables to the chassis or isolate them from the chassis.
 - Be sure the chassis is grounded as outlined in the *Control Hardware Installation Guide*.
-

Use the following procedure to check or set the ground jumper for the port A cable (yellow) and port B cable (green).





TIP

It is easier to set the cable shield ground jumpers before the FTE Bridge module is installed and the cable connections are made.

Step	Action
1	Open the front door on the FTE Bridge module.

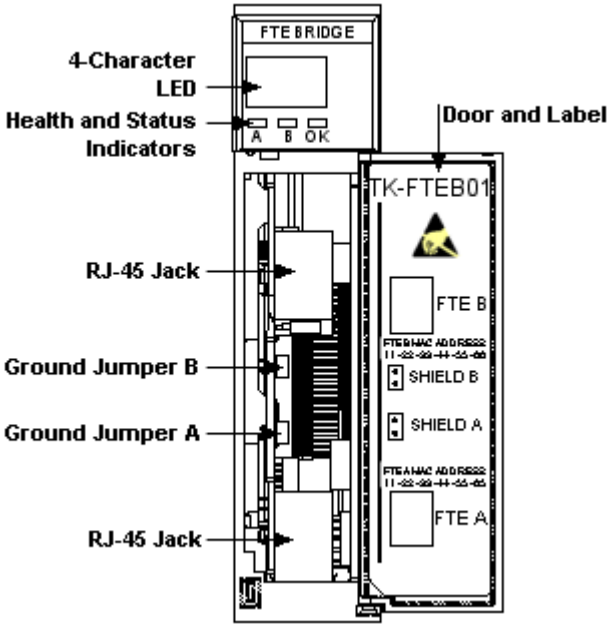
Installation
FTE Bridge Module

Step	Action
2	<p>Locate the hardware jumpers designated as SHIELD A and SHIELD B.</p> 
3	<ul style="list-style-type: none"> To ground the shield on the FTE A link cable end connected to the FTE Bridge module to the chassis, install the jumper across the pins for SHIELD A. To let the shield on the FTE A link cable end connected to the FTE Bridge module “float” (or not be connected to any source of electrical potential), remove the jumper from across the pins for SHIELD A.
	<p>TIP</p> <p>To remove the jumper and keep it handy for future use, just put it on one jumper pin.</p>
4	<ul style="list-style-type: none"> To ground the shield on the FTE B link cable end connected to the FTE Bridge module to the chassis, install the jumper across the pins for SHIELD B. To let the shield on the FTE B link cable end connected to the FTE Bridge module “float” (or not be connected to any source of electrical potential), remove the jumper from across the pins for SHIELD B.

Step	Action
5	If applicable, repeat this procedure for the other FTE Bridge module in a redundant chassis pair (RCP).
6	This completes the procedure. Go to the next section.

A word about MAC addresses

Every FTE Bridge module comes with factory assigned media access control (MAC) addresses for both FTE links. The FTE B link MAC address equals the FTE A link MAC address plus one. The assigned MAC addresses are recorded on a label on the door of the FTE Bridge module.

Installing FTE Bridge module (TC-FTEB01/TK-FTEB01)



ATTENTION

The following procedure assumes that the chassis has been installed and grounded as outlined in the *Control Hardware Installation Guide*, and power is not applied.

Use the following procedure to insert the FTE Bridge module into the chassis. This procedure assumes that chassis power supply is turned OFF.



WARNING

Unless the location is known to be non-hazardous, do **not**:

- connect or disconnect cables,
- install or remove modules,

while the Control system is powered.

Installation
FTE Bridge Module

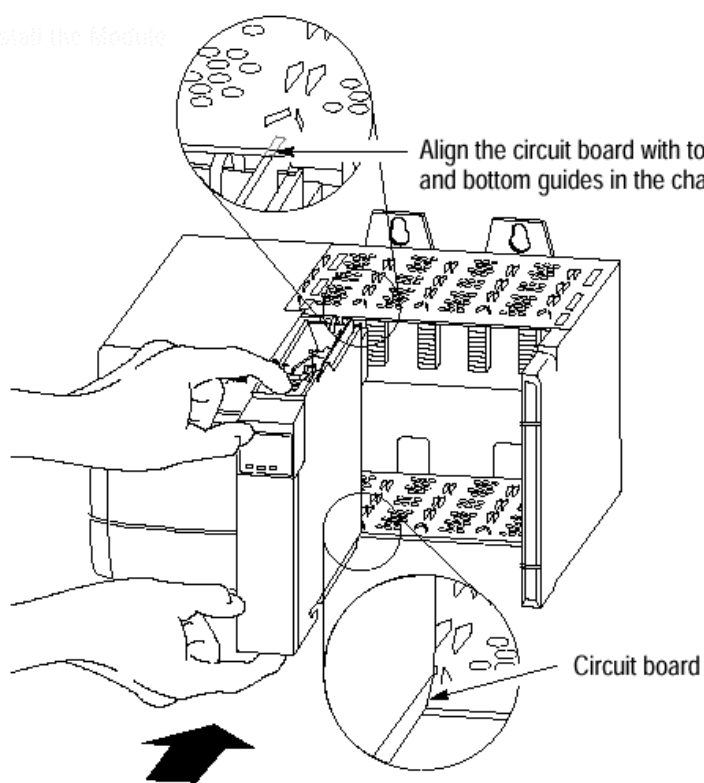
Step	Action
1	<p>Align the module's circuit board with the top and bottom chassis guides for the planned slot location. Typically, slot 0 is reserved for the communication module.</p> <p>(Remember that slot numbering is zero-based and the left most slot is number "0".)</p> <p><i>install the Module</i></p>  <p>Align the circuit board with top and bottom guides in the chassis.</p> <p>Circuit board</p>

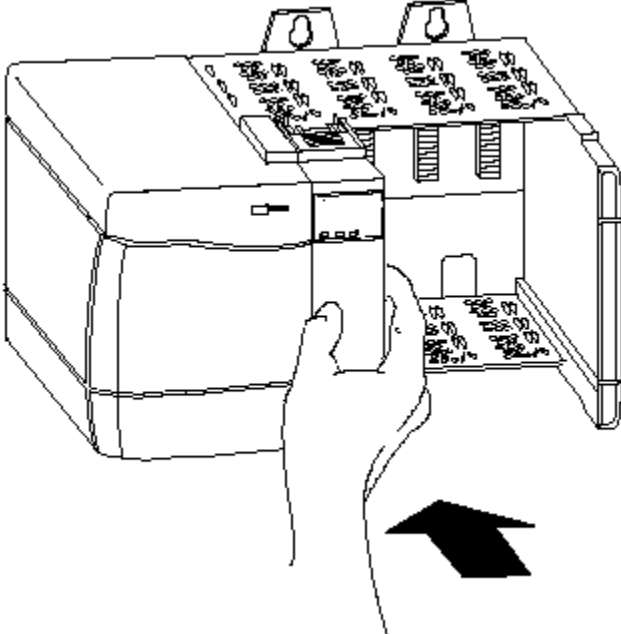
Step	Action
2	<p>Slide the module into the chassis, until the module's locking tabs "click" into position. The module is fully installed when it is flush with the power supply or other installed modules.</p> 
3	Repeat Steps 1 and 2 to install other modules, as required.
4	Go to the next Section <i>Attaching FTE cables</i> .

Attaching FTE cables



WARNING

Unless the location is known to be non-hazardous, do **not**:

- connect or disconnect cables,
 - install or remove modules,
- while the Control system is powered.
-

The FTE Bridge module includes two RJ-45 modular jacks located behind its front door. They provide redundant Ethernet media connections for FTE ports A and B. The dust boots on the cables are color coded yellow for port A and green for port B. The following figure shows the pin out for the 8-pin RJ-45 connector.

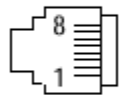

Pin Number	Description
1	TD+ (Transmit positive polarity of twisted pair output)
2	TD- (Transmit negative polarity of twisted pair output)
3	RD+ (Receive positive polarity of twisted pair input)
4	NC (No Connection)
5	NC (No Connection)
6	RD- (Receive negative polarity of twisted pair input)
7	NC (No Connection)
8	NC (No Connection)
Exterior Shield	(Cable/connector chassis ground shield)

Figure 3 8-pin RJ-45 connector pin out.

Use the following procedure to connect the FTE port A and port B cables to the FTE Bridge module. .

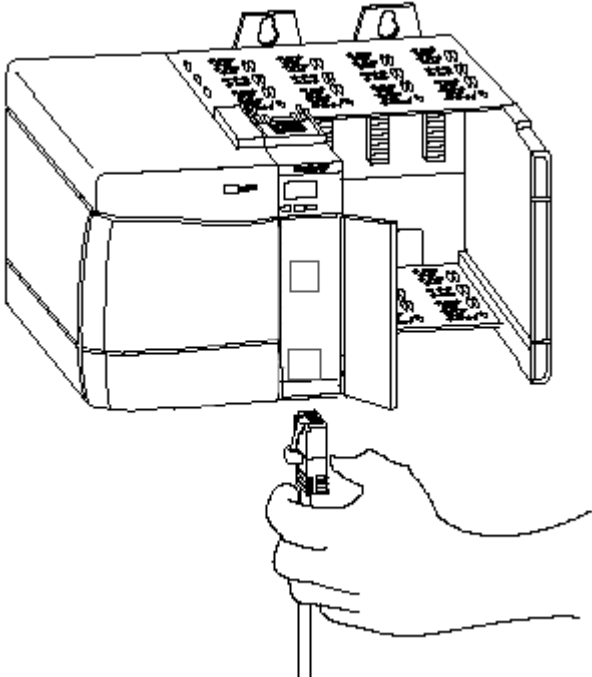
Step	Action
1	<p>Open the module's door and plug the FTE A Link cable RJ-45 plug with yellow dust boot into the bottom port A jack, so it locks into place.</p>  <p>The diagram illustrates the first step of the installation process. It shows a perspective view of the FTE Bridge module with its front door open. A hand is shown holding an RJ-45 cable with a yellow dust boot, preparing to insert it into the bottom port A jack. The module's top cover is also shown open, revealing internal components.</p>

Installation
FTE Bridge Module

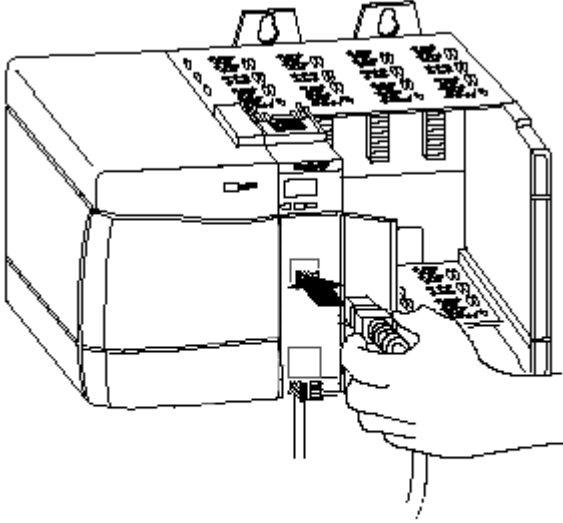
Step	Action
2	<p>Plug the FTE B Link cable RJ-45 plug with green dust boot into the top port B jack, so it locks into place.</p>  <p>The diagram shows a hand inserting an RJ-45 cable into a port on the front panel of the FTE Bridge Module. The module is shown from a three-quarter perspective, with its front door open. The top of the module has two RJ-45 ports labeled 'A' and 'B'. The hand is shown from the right, holding the cable and pushing it into the 'B' port. The cable has a green dust boot on the RJ-45 plug.</p>
3	Dress cables so they exit the bottom of the module and close the front door.
4	Connect the other end of the cable to the Ethernet switch port. Be sure to make all Supervisory FTE network connections.
5	This completes the procedure. Go to the next section.

Configuration

Things to Consider Before Configuring FTE Bridge

Address configuration considerations

The following table provides an overview of things you should consider for the listed IP address assignment.

Address Assignment	Default	Considerations
Base IP Address	10.0.0.0	<div data-bbox="792 814 1279 1045" data-label="Diagram"> <p>The diagram shows the IP address 10.0.0.0 with four arrows pointing to each octet. The first octet (10) is labeled 'Network Number'. The second octet (0) is labeled 'Community Number'. The third octet (0) is labeled 'Can be user defined'. The fourth octet (0) is labeled 'BOOTP incremented based on Device Index for embedded nodes'.</p> </div> <ul style="list-style-type: none"> • The first number in the address represents the network number. <ul style="list-style-type: none"> – Refer to the Fault Tolerant Ethernet Overview and Implementation Guide for more information about IP addressing. • The second number in the address represents the community number. • The third number must be zero • The last number represents the embedded node's Device Index. <ul style="list-style-type: none"> – The default value for the last number must be 0. – The BOOTP server dynamically assigns the FTE Bridge modules IP address by incrementing the last two numbers to equal the unique Device Index setting for the module. For example, if the configured base IP address is 10.100.0.0 and the FTE Bridge module's Device Index is 89, the BOOTP server dynamically assigns 10.100.0.89 as the FTE Bridge

Configuration

Things to Consider Before Configuring FTE Bridge

Address Assignment	Default	Considerations
		module's IP address. If the configured base IP address is 172.20.0.0 and the FTE Bridge Module's Device Index is 1, the BOOTP server dynamically assigns 172.20.0.1 as the FTE Bridge module's IP address. See Setting unique Device Index in this document for details.
Subnet Mask	255.255.0.0	<p>The Subnet Mask maps FTE communities into Ethernet subnets.</p> <p>Refer to the Fault Tolerant Ethernet Overview and Implementation Guide for more information about IP addressing.</p> <p>Routers use subnets to filter messages, the router ignores messages within a port's subnet, and messages to other subnets are forwarded to the appropriate port.</p> <p>The subnet mask configured within a Control Builder System Preferences dialog applies only to the embedded nodes (FTE Bridge modules) communicating with that Server's BOOTP service.</p> <p>The subnet mask can be used within an FTE community to enhance the security of embedded nodes.</p> <p>There are a number of websites that provide more information about subnet masks and how to make subnet calculations. For example, the subnetonline.com site http://www.subnetonline.com/index.html provides access to online calculators.</p>
Default Gateway	0.0.0.0	<p>Use a default gateway to facilitate communications between nodes residing on different networks with different network numbers.</p> <p>Do not change the default value (0.0.0.0) unless instructed to do so by network services.</p> <p>Refer to the Fault Tolerant Ethernet Overview and Implementation Guide for more information about IP addressing.</p> <p>The default gateway should be set to the IP address of the router that connects the two networks. Given the example shown below, "Node A" and "Node B" could not communicate with each other without the default</p>

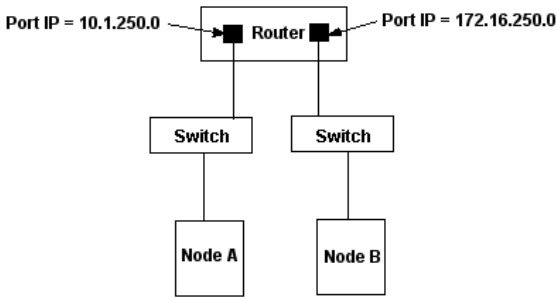
Address Assignment	Default	Considerations
		<p>gateway defined. The default gateway for “Node A” would be the IP address of the port it connects to at its router – 10.1.250.0; the default gateway for “Node B” would be 172.16.250.0, which is the IP address for its router port.</p>  <pre> graph TD Router[Router] --- S1[Switch] Router --- S2[Switch] S1 --- NodeA[Node A] S2 --- NodeB[Node B] </pre> <p>The diagram illustrates a network topology. At the top is a box labeled "Router" with two ports. The left port is labeled "Port IP = 10.1.250.0" and the right port is labeled "Port IP = 172.16.250.0". Below the router are two boxes labeled "Switch". The left switch is connected to the left port of the router, and the right switch is connected to the right port of the router. Below each switch is a box labeled "Node A" and "Node B" respectively, connected to their respective switches.</p>

Configuration

Things to Consider Before Configuring FTE Bridge

Other configuration considerations

The following table summarizes other things you should consider before configuring the FTE Bridge module.

What you should consider. . .	And, why. . .
Do not include other BOOTP servers on network other than Honeywell BOOTP servers bundled with Experion software.	Avoid conflicts in address assignments.
Dynamic Host Configuration Protocol (DHCP) server	If DHCP server is present, be sure it is configured not to respond to BOOTP request to avoid incorrect address range assignments.
Non-Embedded Node IP Address Assignment	Only embedded FTE nodes (FTE Bridge module) receive IP addresses from the BOOTP server based upon the Base IP Address and their Device Index . Refer to the Fault Tolerant Ethernet Overview and Implementation Guide for more information about IP addressing.
Multiple Clusters within One FTE Community	You can have multiple Server clusters within one FTE Community and configure up to 200 nodes, including 99 physical FTE Bridge modules within one community.
BOOTP Support	The Honeywell enhanced BOOTP protocol provides automatic, consistent IP Address assignment for FTE Bridge modules based upon the Base IP Address and their Device Index . It allows address assignment to both FTE links. It also provides a way to identify FTE modules by type and several other enhancements. The FTE Bridge module implements all features of Honeywell enhanced BOOTP protocol, but it does not expose the MAC addresses to the user
Duplicate Address Detection	The FTE Bridge module is designed to gracefully join the FTE network during module startup. It first determines if any other module uses the same IP address; and, in case of address conflict, it does not join a network but instead transitions to “no address” state waiting for a new address assignment.

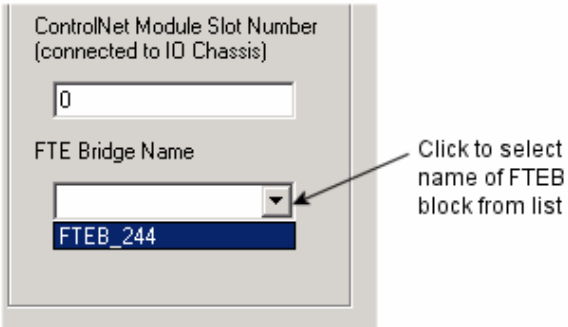
What you should consider. . .	And, why. . .
FTE Bridge module as RSLinx-Like Driver	The FTE Bridge module acts like an RSLinx-like driver for Control Data Access and Control Builder. The driver name is FTEB module tag. Once you add the FTE Bridge Module block to Control Builder, it is added to the internal list of drivers.
Control Processor Module (CPM), Fieldbus Interface Module (FIM), and I/O Link Module (IOLIM) Configuration on FTE.	Once you configure the FTE Bridge module block in Control Builder, you can configure CPM, FIM, and IOLIM on the FTE by selecting FTEB as the RSLinx-like driver.
Series A I/O Module Configuration on FTE with C200	There is no change in I/O module configuration for FTE supervisory network, since the way the CPM accesses I/O data is unchanged.
Series A I/O Module Configuration on FTE with C300	<p>When you assign a Series A - Chassis I/O module to a C300 block in Control Builder, you must configure the name of the FTE Bridge block that represents the FTEB mounted in the Series A I/O chassis to identify the communications path to the IOM on its configuration form. The following illustration shows an excerpt of the FTE Bridge Name field that appears on the IOM's configuration form when the IOM is assigned to a C300 block.</p> 



REFERENCE - INTERNAL

For details of the FTEB Reference parameter, see its description in the Control Builder Parameter Reference at [FTEBLOCK](#)

Configuration

Things to Consider Before Configuring FTE Bridge

I/O memory usage considerations

When the C200 Controller or the FTE Bridge module with C300 Controller makes a connection with a Chassis Series A, or Series A or H rail I/O Module (IOM), the module allocates I/O buffer memory to support the I/O connection data exchange. The C200 Controller and the FTE Bridge module each have total I/O buffer limits and each IOM has I/O buffer size requirements. The sum of all IOM buffers required/configured must be less than the C200 Controller or FTE Bridge module total available. It is unlikely that you will encounter this limitation unless you are using a Serial Interface Module (SIM), Profibus, or DeviceNet interface with your system as well. .

The following table lists the available I/O memory and the required memory per module type for reference.

Available I/O Buffer Memory Capacity	
Controller or I/O Gateway Module	I/O Memory Available
1 C200 CPM	18564 bytes
1 FTEB Module (when used with C300)	8096 bytes
I/O Buffer Memory Table	
Chassis Series A I/O Modules ¹	I/O Memory Required per Module (bytes)
TC_IAH061	152
TC_IAH161	200
TC_IDA161	132
TC_IDD321	132
TC_IDJ161	132
TC_IDK161	132
TC_IDW161	132
TC_IDX081	144
TC_IDX161	144
TC_IXL061	152
TC_IXL062	152

Configuration

Things to Consider Before Configuring FTE Bridge

Available I/O Buffer Memory Capacity	
TC_IXR061	152
TC_OAH061	180
TC_OAV061	180
TC_OAV081	196
TC_ODA161	136
TC_ODD321	136
TC_ODJ161	136
TC_ODK161	136
TC_ODX081	152
TC_ODX161	152
TC_ORC081	136
TC_ORC161	136
Serial Interface Module	732 + (1 to 7 additional connections) * 732
DeviceNet - DNET_IM	364 + output data size + input data size
Profibus - PBIM_SST	600 + output data size + input data size
Series A Rail I/O Modules ¹	I/O Memory Required per Module (bytes)
TC_FIAH81	136
TC_FID161	132
TC_FIDA81	132
TC_FIL081	140
TC_FIR081	140
TC_FOA041	140
TC_FOD161	128

Configuration

Things to Consider Before Configuring FTE Bridge

Available I/O Buffer Memory Capacity	
TC_FODA81	128
TC_FOR081	128
Series H Rail I/O Modules ¹	I/O Memory Required per Module (bytes)
TC_PIA082	140
TC_PIB161	120
TC_PIL081	136
TC_POA081	160
TC_POB041	132
¹ The C300 with FTE Bridge module only supports the following chassis-based Modules: <ul style="list-style-type: none">• Serial Interface Module• DeviceNet - DNET_IM• Profibus - PBIM_SST• Pulse Input	

Configuring FTE Bridge



ATTENTION

The procedures in this section assume that you:

- Have installed the Experion release R300 software and have the Control Builder application running. If you have not installed the Experion software, please refer to the *Software Installation and Upgrade Guide* for details. If you have not launched Control Builder, please refer to the *Control Building Guide* for details.
- Have installed and configured your Fault Tolerant Ethernet network. If you have not installed the FTE network, please refer to the *Fault Tolerant Ethernet Overview and Implementation Guide* in Knowledge Builder, and setup your FTE supervisory network before continuing with this procedure.
- Are making initial IP address settings before any FTE Bridge module has been configured or powered up.
- Are configuring the components on a Server connected to the FTE supervisory network. If you are configuring the components offline on a Station or computer that is connected to another network, be careful when entering the IP addresses.

Setting up addresses



The procedure to check the base IP address, subnet mask, and default gateway settings is found in the System Preferences section of the *Control Building User's Guide*.



Checking status of BOOTP server service

Use the following procedure to confirm that the BOOTP Server service is running.

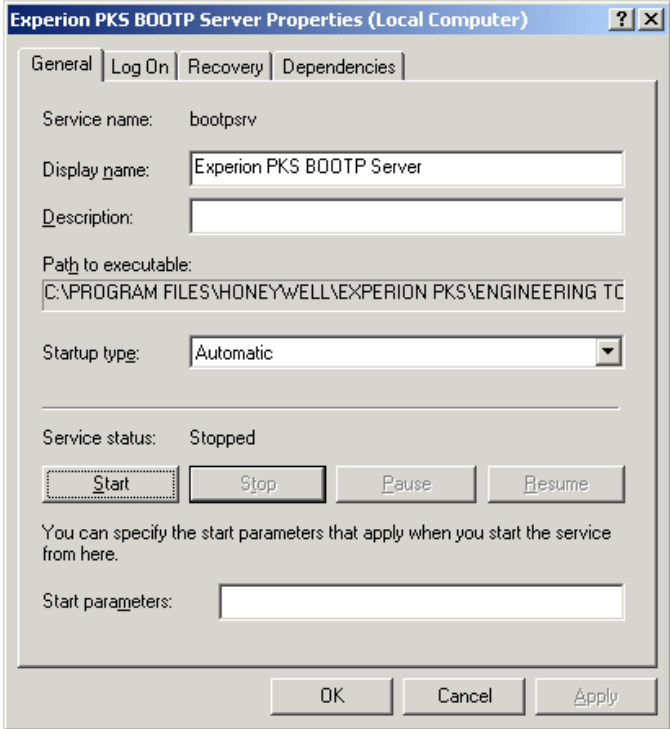
Step	Action	Result
1	On the taskbar, click the Start button, and then click Settings->Control Panel .	Opens the Control Panel window.
2	Double-click the Administrative Tools icon.	Opens the Administrative Tools window.
3	Double-click the Services icon.	Opens the Services window.
4	In the vertical scroll bar, use the	Confirm that Started is listed in the

Configuration
Configuring FTE Bridge

Step	Action	Result
	scroll box to scroll items in the open window to find the Experion BOOTP Server service.	Status column for the service.
5	<ul style="list-style-type: none"> If Started is listed, go to Step 9. If Status column is blank, go to Step 6. 	
6	Double-click the Experion BOOTP Server icon.	Opens the Experion BOOTP Server Properties dialog.
		
	<p>TIP</p> <p>If the Start button is unavailable, the BOOTP Server service is started. If the Stop button is unavailable, the BOOTP Server service is stopped, You can use these buttons to stop and start the BOOTP service, as required.</p>	

Step	Action	Result
7	Click the Start button.	Initiates service start function and opens the Service Control dialog to track progress.
8	After the Service Control dialog closes, check that the Service status is Started and the Start button is unavailable.	Confirm that service has started.
9	Click the OK button.	Closes Experion BOOTP Server Properties dialog.
10	Click the Close button  .	Closes Services window.
11	Click the Close button  .	Closes Administrative Tools window.
12	This completes the procedure.	Go to the next section.

Creating FTE Bridge module block



ATTENTION



You must create the FTE Bridge module function block before creating blocks for Control Processor Module (CPM), Fieldbus Interface Module (FIM), and I/O Link Interface Module (IOLIM), so you can specify the FTE Bridge block name as the **Driver Name** on the configuration forms for the latter blocks.

Also, you must create the FTE Bridge module function block in Control Builder before you can view it in the Network Tools (**NTools**) utility.

Use the following procedure to create a tagged function block to represent the installed FTE Bridge module. This procedure assumes that you have configured a valid base IP address through the **Embedded FTE** tab on the **System Preferences** dialog. See the previous [Setting up addresses](#) procedure. You cannot create a FTE Bridge module block with an invalid address (0.0.0.0).



Step	Action	Result
1	In Control Builder, click the File menu, and then choose New->Interface Modules->FTEB-FTE Bridge Module .	Opens SYSTEM:FTEB Block, FTEB_XX- Parameters [Project] configuration form. Where XX equals a system assigned unique number.



Configuration
Configuring FTE Bridge

Step	Action	Result
	<p>TIP</p> <p>The block name can be up to 16 characters long and must contain at least one letter (A-Z). It must not contain an embedded space or leading space, and dots are allowed in parameter naming only.</p>	
2	<p>Type the desired block name in the Name box or accept the assigned name. The Unique name identifies the component within Control Builder views and Station displays. Press the TAB key.</p>	<p>Moves cursor to Device Index box.</p>
3	<p>Type the Device Index number that matches the one set on BCD rotary switches of the FTE Bridge module that this block represents. Press the TAB key.</p>	<p>Moves cursor to Module Slot Number box</p>
4	<p>Click the arrow and select the number of the chassis slot where the physical FTE Bridge module is installed. Press the TAB key.</p> <p>(Remember that chassis slot numbering is zero based, so the first slot on the left is number "0".)</p>	<p>Moves cursor to This module is redundant check box.</p>
	<p>TIP</p> <p>After you select the Module Slot Number, the IP Address is updated to match the IP address previously configured through the System Preferences dialog plus the Device Index number you just entered in Step 3. For example, if the IP Address is 10.10.0.0 and you configured a Device Index of 85, the assigned IP Address would be 10.10.0.85</p>	
5	<ul style="list-style-type: none"> If the FTE Bridge module is installed in a non-redundant C200 Controller or Fieldbus Interface Module (FIM) chassis, leave the This module is redundant check box blank. Click the Server History tab. 	<p>Opens Server History tab. Go to Step 7</p>

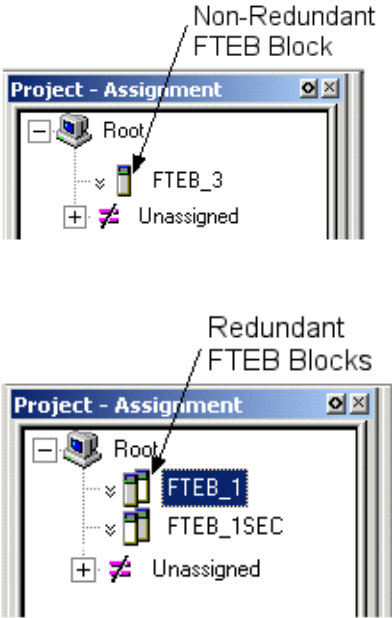
Step	Action	Result
	<ul style="list-style-type: none"> If the FTE Bridge module is one of a pair of modules installed in a redundant C200 Controller or FIM chassis, click the This module is redundant check box to select it. Press the TAB key. 	Moves cursor to Secondary Name box. Go to Step 6.
6	Type the desired secondary block name in the Secondary Name box or accept the default, which is the name entered in Step 2 with a suffix of "SEC". Click the Server History tab.	Opens the Server History tab.
7	Use the online help to fill in the applicable data on the Server History tab. Click the Server Displays tab.	Opens the Server Displays tab.
	<p>ATTENTION</p> <p>If you are using a distributed Server architecture and/or Areas is enabled in Station, you must enter an assigned area name in the Control Area box.</p>	
8	Use the online help to fill in the applicable data on the Server Displays tab. Click the Control Confirmation tab	Opens the Control Confirmation tab.
9	Use the online help to fill in the applicable data on the Control Confirmation tab. You must have a license for the Electronic Signature option to use this tab. Click the Identification tab.	Opens the Identification tab.

Configuration
Configuring FTE Bridge

Step	Action	Result
10	Use the online help to fill in the applicable data on the Identification tab. Click the OK button.	<p>Closes the SYSTEM:FTEB Block, FTEB_XX- Parameters [Project] configuration form and creates FTE Bridge block icon in Project tab.</p> 
	<p>TIP</p> <p>You can only view FTE Bridge Blocks in Project tab set for the Assignment view. The Assignment view shows the relationship among all blocks while the Containment view only shows templates that contain other templates or Control Modules (CM), Sequential Control Modules, (SCM) and basic blocks. To toggle the view, right-click in an open area of the tab window and select Assignment View or Containment View from the shortcut menu, as applicable.</p>	
11	Is this a redundant FTE Bridge module configuration?	<p>If the answer is Yes, go to the next Step.</p> <p>If the answer is No, go to Step 18.</p>

Step	Action	Result
12	In the Project tab, double-click the Secondary FTE Bridge block icon.	Opens the SYSTEM:FTEB Block, FTEB_XXSEC- Parameters [Project] configuration form.
	<p>TIP</p> <p>The configuration information on the Main tab for the secondary FTE Bridge block reflects the data entered on the Main tab for the primary FTE Bridge block. Check that the IP address is the same except for the device index component that is incremented by 1, and the module slot location is the same. This information is view only. You can change the name of the block, if desired.</p>	
13	Type the desired block name in the Name box or accept the assigned name. The Unique name identifies the component within Control Builder views and Station displays. Click the Server History tab.	Opens the Server History tab.
14	Use the online help to fill in the applicable data on the Server History tab. Click the Server Displays tab.	Opens the Server Displays tab.
	<p>ATTENTION</p> <p>If you are using a distributed Server architecture and/or Areas is enabled in Station, you must enter an assigned area name in the Control Area box.</p>	
15	Use the online help to fill in the applicable data on the Server Displays tab. Click the Control Confirmation tab	Opens the Control Confirmation tab.
16	Use the online help to fill in the applicable data on the Control Confirmation tab. You must have a license for the Electronic Signature option to use this tab. Click the Identification tab.	Opens the Identification tab.
17	Use the online help to fill in the applicable data on the Identification tab. Click the OK button.	Closes the SYSTEM:FTEB Block, FTEB_XXSEC- Parameters [Project] configuration form.

Configuration
Configuring FTE Bridge

Step	Action	Result
18	This completes the configuration procedure.	You can now load the FTE Bridge Block to the FTE Bridge module.

Loading FTE Bridge block

With the FTE network installed, you load the FTE Bridge block through Control Builder as you would any other block. Use the following procedure as a guide.



TIP

- The FTE Bridge module must be installed and powered before you can load data to it. See the *Operation* section for details on *Applying power to FTE Bridge Module*.
- If you have a **Qualification and Version Control System (QVCS)** license, you can use the relaxed loading function to load a block without checking it in to QVCS. Once you check a block into QVCS, it is subject to the QVCS load requirements.

Step	Action	Result
1	In the Project tab, click the FTE Bridge block icon.	Selects the block you want to load.
2	In the Controller menu, click Load .	Opens Load Dialog .
	<p>TIP You can right-click the FTE Bridge block icon and select Load from the shortcut menu or just click the Load  button in the toolbar with the block selected, as alternate methods to open the Load Dialog.</p>	
3	Be sure the Load check box is selected. Click the OK button.	Initiates the load operation and opens the Load dialog to show the progress of the load as well as display any load detected errors.
4	When load completes, click the Monitoring tab.	Opens Monitoring tab.
5	Confirm that FTE Bridge block icon now appears. See the following table Viewing FTE Bridge icon in Monitoring tab to determine the	Confirm block is loaded and status of associated module.



Step	Action	Result
	status of the module from the color coded icon.	
6	Repeat this procedure to load another FTE Bridge block, if required.	Load all FTE Bridge blocks including secondary FTE Bridge block for redundant pair.
7	This completes the procedure.	Go to the next section.







REFERENCE - INTERNAL

See the *Control Building Guide* for more information about loading control strategy components.





Table 1 Viewing FTE Bridge icon in Monitoring tab

If Icon for Non-Redundant FTE Bridge block Is . . .	Then, Module Status Is . . .
Green 	Control Data Access (CDA) server can communicate with the module.
Red ! 	CDA server cannot communicate with the module.

If Icon for Redundant Primary FTE Bridge Block Is . . .	Then, Module Status Is . . .
Green and Secondary is White 	Module pairs are synchronized and CDA server can communicate with the primary module.
Green and Secondary is Yellow 	Module pairs are not synchronized but secondary partner is visible and synchronization is in progress. CDA server can communicate with primary module.
Green and Secondary is transparent 	Module pairs are not synchronized and secondary partner is not visible. CDA server can communicate with primary module.
Red and Secondary is White ! 	CDA server cannot communicate with the primary module.

Configuration

Configuring FTE Bridge

If Icon for Redundant Secondary FTE Bridge Block Is . . .	Then, Module Status Is . . .
Green and Primary is White 	Module pairs are synchronized and CDA server can communicate with the secondary module.
Green and Primary is Yellow 	Module pairs are not synchronized but primary partner is visible and synchronization is in progress. CDA server can communicate with secondary module.
Green and Primary is Transparent 	Module pairs are not synchronized and primary partner is not visible. CDA server can communicate with secondary module.
Red and Primary is White 	CDA server cannot communicate with the secondary module.

Operation

Starting and Monitoring FTE Bridge Module

Applying power to FTE Bridge Module

The chassis-mounted FTE Bridge Module receives its power from the chassis power supply. You cycle power to the module by turning the power supply switch On and Off. The following table lists some common power application scenarios that you should consider before powering up the FTE Bridge Module for the first time.

Table 2 Typical FTE Bridge Module Power Up Scenarios

If You Are Applying Power . . .	Then, Consider This . . .
For the first time.	The FTE Bridge module requests an IP address from the BOOTP Server. The BOOTP Server responds with an IP address that is based upon the base IP address configured in Control Builder and the Device Index setting for the FTE Bridge module. See Setting up addresses and Setting unique Device Index for details. This is considered a cold start.
Subsequent to the initial power up as part of normal chassis power cycling.	The FTE Bridge module does not request an IP address from the BOOTP Server. This is considered a warm start.
After changing the Device Index on the FTE Bridge module or moving the FTE Bridge module to a different slot in the chassis.	You must make corresponding configuration changes for the FTE Bridge block in Control Builder. See Creating FTE Bridge module block for more details. This is like applying power for the first time or a cold start. See the first row above.

Monitoring front-panel display

The FTE Bridge module front panel includes a 4-character, alpha-numeric display to show the status of the module. During normal operation, the display alternates between showing its Device Index and current state. The following table lists possible state indications and gives a brief explanation of their meaning.

Operation

Starting and Monitoring FTE Bridge Module

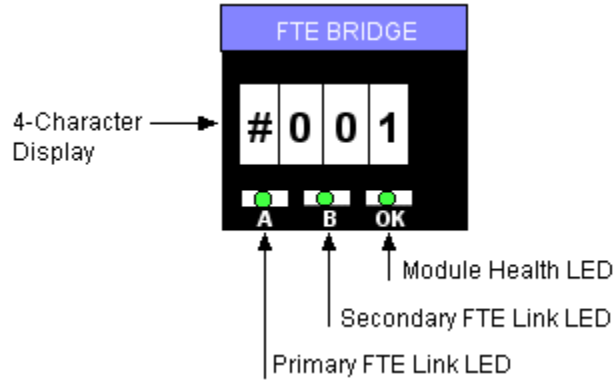

Figure 4 FTE Bridge module front panel indicators.

Table 3 Possible Display Indications

If Display Indication Is . . .	Then, It Means . . .
OK	The FTE Bridge module is running application code and is functioning properly.
FAIL	Application has crashed. Alternates with crash code display.
ALIV	Executing boot code, no application image is loaded. See Loading Personality image .
RDY	Module is ready for firmware download. See Loading Boot code .
- BP -	Requesting IP address through BOOTP Server.
BOOT	Boot is in progress and self-test is being run.
WDTd	Watchdog timer diagnostics.
TXXX	Performing startup test number XXX (see Table 5 FTE Bridge Module Test Codes).
PASS	Passed all startup tests.
BKUP	Module is functioning as secondary in redundant pair.
#0XX	XX is the Device Index number setting for the module.

Monitoring front-panel LEDs

The FTE Bridge module front panel includes three red/green Light Emitting Diodes (LED). The A and B LEDs monitor port A and port B FTE link integrity and the OK LED monitors general module health. The following table summarizes possible LED indications.

Table 4 Possible LED Indications

If OK LED Is . . .	Then, It Means . . .
Off	No power, watchdog timer expiration, or LED has failed.
Red (Solid)	Fatal module failure.
Red (Blinking)	Non-fatal module failure. Also used to indicate firmware update in progress.
Green (Blinking)	Module is Okay – there are no active connections open to the module. If module is part of a redundant pair, the modules are not synchronized.
Green (Solid)	Module is Okay – one or more active connections are open to the module. If module is part of a redundant pair, the modules are synchronized.
If A or B LED Is . . .	Then, It Means . . .
Red (Solid)	Link integrity check failed – no Ethernet signal detected or cable is not present.
Off	Link integrity is OK – no transmit activity.
Green (Blinking)	Link integrity is OK – there is transmit activity. Typically, the A or B LED blinks green/off to indicate reception of incoming Ethernet frames over the given FTE link.
	<p>TIP</p> <p>The A and B Green LEDs blink faster for high Ethernet traffic conditions and may stay on solid in extreme traffic conditions.</p>

Using Control Builder Interface

About Monitoring mode

Once a control strategy is loaded to a controller assigned to a FTE Bridge module, you can interact with on-line data through the **Monitoring** tab in Control Builder. You simply click the **Monitoring** tab to open it as shown below.

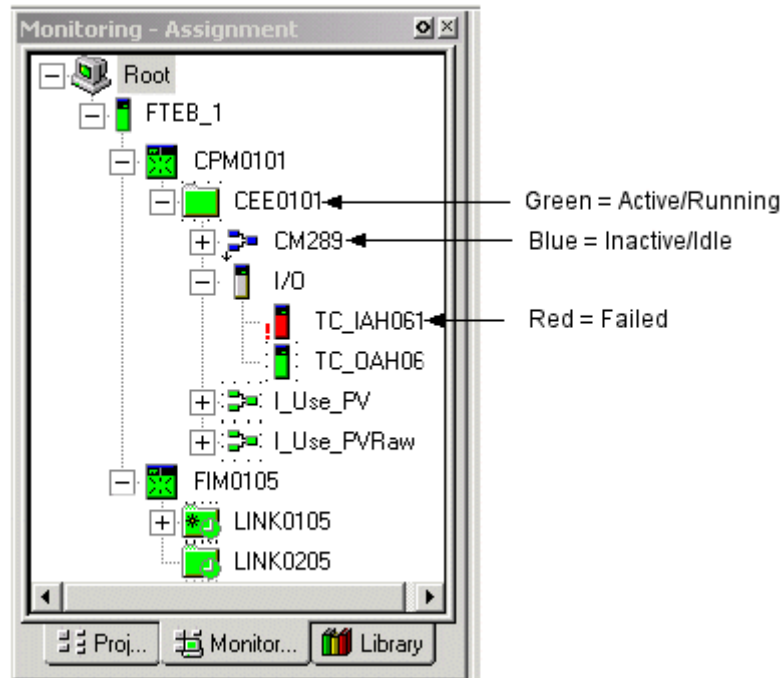

As shown in the figure above, Control Builder uses color-coding to visually represent the current status of a given component. The tasks you can perform in the **Monitoring** mode depend on the access level you used to sign-on to this session of Control Builder.



REFERENCE - INTERNAL

Please refer to the *Control Building Guide* for more information about using Control Builder for on-line monitoring and other functions.

Monitoring status through block configuration form

The configuration form for the FTE Bridge block includes various tabs that provide access to parameters for configuration through the **Project** tab and for monitoring through the **Monitoring** tab. Use the following procedure to access the configuration form for a FTE Bridge block in the **Monitoring** tab. This procedure assumes that you have logged on to Control Builder and have loaded your control strategy to the controller.

Step	Action	Result
1	In Control Builder, click the Monitoring tab.	Opens the Monitoring tab.
	TIP You can only view FTE Bridge Blocks in Monitoring tab set for the Assignment view. The Assignment view shows the relationship among all blocks while the Containment view only shows templates that contain other templates or Control Modules (CM), Sequential Control Modules, (SCM) and basic blocks. To toggle the view, right-click in an open area of the tab window and select Assignment View or Containment View from the shortcut menu, as applicable.	
2	Double-click FTE Bridge block icon.	Opens System: FTEB Block, Name – Parameters [Monitoring] configuration form. Where <i>Name</i> represents the name configured by the user or assigned by the system.
3	Click tab you want to open. The Main tab opens by default.	Opens selected tab.
4	Repeat Step 3 to view other tabs, as desired.	Select tab you want to view.
5	When finished viewing, click the OK button.	Closes the System: FTEB Block, Name – Parameters [Monitoring] configuration form.
6	This completes the procedure.	Go to the next section.



REFERENCE - INTERNAL

Refer to the [Control Builder Parameter Reference](#) for more details on a given parameter.

Viewing Main tab

The following table summarizes the parameter data you can monitor on the **Main** tab of the configuration form for the selected FTE Bridge block. See [Monitoring status through block configuration form](#) for details on accessing the FTE Bridge block configuration form **Main** tab in the **Monitoring** tab.

Plain Text	Parameter Name	User Configurable	Notes
Name	NAME	Project Only	System assigned or user configured unique name. Consisting of up to 16 characters and at least one character must be a letter (A-Z).
Database Release	CURRENTREL	No	Identifies current system software release installed.
Image Version	IMAGEVER	No	Identifies current version of firmware installed in module.
Device Index	DEVICEIDX	Project Only – Matches Hardware Setting	Set on FTE Bridge module switches.
Module Slot Number	SLOTNUMBER	Project Only	Chassis slot number where FTE Bridge module is installed.
IP Address	IPADDRESS	No	Base IP Address plus configured Device Index.
This module is redundant	MODISREDUN	Project Only	Module is part of redundant pair.
Secondary Name	SECNAMESTRG	Project Only	System assigned or user configured unique name for secondary block.
Redundant Chassis ID	RDNCHASSISID	No	Identifies physical chassis in a redundant chassis pair without regard to chassis redundancy state.
Synchronization	RDNSYNCSTATE	No	Shows current synchronization state of

Plain Text	Parameter Name	User Configurable	Notes
State			module.
Redundancy Compatibility	RDNCMPT	No	Indicates whether or not modules residing in same slot of a redundant chassis pair are compatible.
Redundancy Loss of Sync	RDNLOS	No	Provides enumeration for loss of synchronization.
CPU Free Average	CPUFREEAVG	No	Gives rolling time average of free CPU not currently used for processing by CPM. Units are percent.
CPU Free Min	CPUFREEMIN	No	Gives historic minimum of unused CPU available to CPM. Units are percent.
Reset Statistics	STATRESET	No	Click button to reset all statistical parameters for block.

Viewing UDP/TCP tab

The following table summarizes the parameter data you can monitor on the **UDP/TCP** tab of the configuration form for the selected FTE Bridge block. See [Monitoring status through block configuration form](#) for details on accessing the FTE Bridge block configuration form **UDP/TCP** tab in the **Monitoring** tab.

Plain Text	Parameter Name	User Configurable	Notes
UDP Statistics (Provides unreliable connectionless packet delivery service between clients.)			
Datagrams Delivered	UDPINDGRAMS	No	Total number of User Datagram Protocol (UDP) datagrams delivered to destination protocol ports.
Datagrams for Unknown Ports	UDPNOPORTS	No	Total number of received UDP datagrams for which there was no application at the destination port.

Operation

Using Control Builder Interface

Plain Text	Parameter Name	User Configurable	Notes
Datagrams Dropped for errors	UDPINERRORS	No	Number of received UDP datagrams that could not be delivered.
Datagrams Sent to Applications	UDPOUTDGRAMS	No	Total number of UDP datagrams sent from this entity.
TCP Statistics (Provides reliable stream delivery service between clients.)			
Active Opens	TCPACTIVEOPEN	No	Number of times TCP connections have made a direct transition to the SYN-SENT state from the CLOSED state.
Passive Opens	TCPPASSIVEOPENS	No	Number of times TCP connections have made a direct transition to the SYN-RCVD state from the LISTEN state.
Failed Connection Attempts	TCPATTEMPTFAILS	No	Number of times TCP connections have made a direct transition to CLOSED state from either SYN-SENT state or SYN-RCVD state, plus number of times TCP connections have made a direct transition to LISTEN state from SYN-RCVD state.
Connections Resets	TCPESTABRESETS	No	Number of times TCP connections have made a direct transition to CLOSED state from either ESTABLISHED state or CLOSE-WAIT state.
Current Connections	TCPCURRESTAB	No	Number of TCP connections for which current state is either ESTABLISHED or CLOSE-WAIT.

Plain Text	Parameter Name	User Configurable	Notes
Segments Received	TCPINSEGS	No	Total number of segments received, including those received in error.
Segments Sent	TCPOUTSEGS	No	Total number of segments sent, including those on current connections but excluding those containing only retransmitted octets.
Segments Retransmitted	TCPRETRANSSEGS	No	Total number of segments retransmitted – that is, number of TCP segments transmitted containing one or more previously transmitted octets.
Segments Discarded For Errors	TCPINERRS	No	Total number of segments received in error (for example., bad TCP checksums).
Reset Segments Sent	TCPOUTRESETS	No	Number of TCP segments sent containing the RST flag.
Local UDP Listeners	UDPLISTENERS	No	Shows path information for all open ports on the FTE Bridge module.
Current TCP Connections	TCPCONNTABLE	No	Shows path information for all currently connected clients of the FTE Bridge module.

Viewing IP/ICMP

The following table summarizes the parameter data you can monitor on the **IP/ICMP** tab of the configuration form for the selected FTE Bridge block. See [Monitoring status through block configuration form](#) for details on accessing the FTE Bridge block configuration form **IP/ICMP** tab in the **Monitoring** tab.

Plain Text	Parameter Name	User Configurable	Notes
IP Statistics (Provides packet delivery services between nodes.)			
Datagrams Received from Below.	IPINRECEIVES	No	Total number of input datagrams received from connected nodes, including those received in error.
Datagrams Format Errors Drops	IPINHDRERRORS	No	Number of input datagrams discarded due to errors in their Internet Protocol (IP) headers, including bad checksums, version number mismatch, other format errors, time-to-live exceeded, errors discovered in processing their IP options, etc.
Datagrams Misdelivery Drops	IPINADDRERRORS	No	Number of input datagrams discarded because the IP address in their IP header's destination field was not a valid address to be received at this entity.
Unknown Protocol Datagrams	IPINUNKNOWNPORTS	No	Number of locally-addressed datagrams received successfully but discarded because of an unknown or unsupported protocol.
Datagrams Discarded for Resrc:	IPINDISCARDS	No	Number of input IP datagrams for which no problems were encountered to prevent their continued processing, but which were

Plain Text	Parameter Name	User Configurable	Notes
			discarded; for example, for lack of buffer space.
Datagrams Delivered Above	IPIDELIVERS	No	Total number of input datagrams successfully delivered to IP user-protocols, including Internet Control Message Protocol (ICMP).
Datagram Sent Out	IPOUTREQUESTS	No	Total number of IP datagrams which local IP user-protocols (including ICMP) supplied to IP in requests for transmission.
Out Datagrams Discarded	IPOUTDISCARDS	No	Number of output IP datagrams for which no problem was encountered to prevent their transmission to their destination, but which were discarded; for example, for lack of buffer space.
Datagrams Drops for No Routes	IPOUTNOROUTES	No	Number of IP datagrams discarded because no route could be found to transmit them to their destination.
Fragments Needing Reassembly	IPREASSEMREQS	No	Number of IP fragments received which needed to be reassembled at this entity.
Fragments Reassembled	IPREASSEMOKS	No	Number of IP datagrams successfully reassembled.
Fragment Reassembly Fails	IPREASSMFAILS	No	Number of failures detected by the IP reassembly algorithm, for whatever reason: timed out, errors, etc.
Datagrams Fragmented	IPFRAGOKS	No	Number of IP datagrams that have been successfully

Operation

Using Control Builder Interface

Plain Text	Parameter Name	User Configurable	Notes
			fragmented at this entity.
Datagrams Fragmentation Fails	IPFRAGFAILS	No	Number of IP datagrams that have been discarded because they needed to be fragmented at this entity but could not be. For example, because their do not Fragment flag was set.
Fragments Created	IPFRAGCREATES	No	Number of IP datagram fragments that have been generated as a result of fragmentation at this entity.
Routing Entries Discarded	IROUTINGDISCARDS	No	Number of routing entries which were chosen to be discarded even though they are valid.
ICMP Statistics (Controls transmission of error and control messages between hosts and gateways.)			
Messages Received	ICMPINMSGs	No	Total number of ICMP messages which the entity received.
Messages with Format Errors	ICMPINERRORS	No	Number of ICMP messages which entity received but determined as having ICMP-specific errors such as bad ICMP checksums and bad length.
Dest. Unreachable Msgs Recvd	ICMPINDESTUNREAC HS	No	Number of ICMP Destination Unreachable messages received.
Echo Messages Recvd	ICMPINECHOS	No	Number of ICMP Echo (request) messages received.
Echo Reply Messages Recvd	ICMPINECHOREPS	No	Number of ICMP Echo Reply messages received.
Messages Sent	ICMPOUTMSGs	No	Total number of ICMP

Plain Text	Parameter Name	User Configurable	Notes
			messages which this entity attempted to send.
Out Error Messages	ICMPOUTERRORS	No	Number of ICMP messages which this entity did not send due to problems discovered within ICMP such as a lack of buffers.
Dest. Unreachable Msgs Sent	ICMPOUTDESTUNREA CHS	No	Number of ICMP Destination Unreachable messages sent.
Echo Messages Sent	ICMPOUTECHOS	No	Number of ICMP Echo (request) messages sent.
Echo Reply Messages Sent	ICMPOUTECHOREPS	No	Number of ICMP Echo Reply messages sent.

Viewing FTE tab

The following table summarizes the parameter data you can monitor on the **FTE** tab of the configuration form for the selected FTE Bridge block. See [Monitoring status through block configuration form](#) for details on accessing the FTE Bridge block configuration form **FTE** tab in the **Monitoring** tab.

Plain Text	Parameter Name	User Configurable	Notes
FTE Mart Statistics (Provides statistics related to the MAC Address Resolution Table (MART). This deals with on-line media access control (MAC) address mapping. Two separate tables are maintained – One for FTE nodes and one for non-FTE nodes. The media access control address entry information is obtained by extracting the source media access control address from received diagnostic messages.)			
Address Count	FTEMARTADDRCOUNT	No	Number of IP addresses contained in FTE MART.
Max Depth	FTEMARTMAXDEPTH	No	Maximum depth that the FTE MART has reached (largest number of entries in table).
Average Depth	FTEMARTAVGDEPTH	No	Average depth of FTE MART (average number of

Operation

Using Control Builder Interface

Plain Text	Parameter Name	User Configurable	Notes
			entries in table).
Address Collisions	FTEMARTCOLLCOUNT	No	Number of collisions that have occurred when hashing the FTE MART.
Current FTE Traffic			
LAN_A Tx Rate (kBit/sec)	LANATXRATE	No	Indicates communication transmission rate in kilobits per second (kbps) for port A (Yellow Tree Port) on the FTE Bridge.
LAN_B Tx Rate (kBit/sec)	LANBTXRATE	No	Indicates communication transmission rate in kilobits per second (kbps) for port B (Green Tree Port) on the FTE Bridge.
LAN_A Rx Rate (kBit/sec)	LANARXRATE	No	Indicates communication receive rate in kilobits per second (kbps) for port A (Yellow Tree Port) on the FTE Bridge.
LAN_B Rx Rate (kBit/sec)	LANBRXRATE	No	Indicates communication receive rate in kilobits per second (kbps) for port B (Green Tree Port) on the FTE Bridge.
FTM Statistics			
Number of FTE nodes	NUMFTENODES	No	Current number of FTE nodes within FTE community.
Max number of FTE nodes	MAXFTENODES	No	Maximum number of FTE nodes that have been detected within FTE community.
Max node ID	MAXNODEID	No	Highest Device Index supported within FTE community.

Plain Text	Parameter Name	User Configurable	Notes
IP checksum errors	BADIPCSUM	No	Number of FTE IP messages which were received but determined as having bad IP checksums.
UDP checksum errors	BADUDPCSUM	No	Number of FTE UDP messages which were received but determined as having bad UDP checksums.
Non-FTE Mart Statistics			
Address Count	NONFTEMARTADDRCOUNT	No	Number of IP addresses contained in non-FTE MART.
Max Depth	NONFTEMARTMAXDEPTH	No	Maximum depth that non-FTE MART has reached (largest number of entries in table).
Average Depth	NONFTEMARTAVGDEPTH	No	Average depth of non-FTE MART (average number of entries in table).
Address Collisions	NONFTEMARTCOLLCOUNT	No	Number of collisions that have occurred when hashing non-FTE MART.
Peak FTE Traffic			
LAN_A Tx Rate Max (kBit/sec)	LANATXRATEMAX	No	Indicates maximum communication transmission rate in kilobits per second (kbps) for port A (Yellow Tree Port) on the FTE Bridge.
LAN_B Tx Rate Max (kBit/sec)	LANBTRATEMAX	No	Indicates maximum communication transmission rate in kilobits per second (kbps) for port B (Green Tree Port) on the FTE Bridge.

Operation

Using Control Builder Interface

Plain Text	Parameter Name	User Configurable	Notes
LAN_A Rx Rate Max (kBit/sec)	LANARXRATEMAX	No	Indicates maximum communication receive rate in kilobits per second (kbps) for port A (Yellow Tree Port) on the FTE Bridge.
LAN_B Rx Rate Max (kBit/sec)	LANBRXRATEMAX	No	Indicates maximum communication receive rate in kilobits per second (kbps) for port B (Green Tree Port) on the FTE Bridge.
LAN_A (Yellow) failed	LANAFAILED	No	Status indicator for port A (Yellow Tree Port) on the FTE Bridge. If this LED is lit, it is an indication that communications have failed on Port A.
LAN_B (Green) failed	LANBFAILED	No	Status indicator for port B (Green Tree Port) on the FTE Bridge. If this LED is illuminated it is an indication that communications have failed on Port B.
InterLAN comm. failed	INTERLANFAILED	No	Status indicator for Inter-LAN communications – indicates that inter-LAN communications have failed.
Crossover cable failed	XOVERFAILED	No	Status indicator for Crossover cable – indicates that the Crossover cable has failed.

Viewing ICP Bridging tab

The following table summarizes the parameter data you can monitor on the **ICP Bridging** tab of the configuration form for the selected FTE Bridge block. See [Monitoring status through block configuration form](#) for details on accessing the FTE Bridge block configuration form **ICP Bridging** tab in the **Monitoring** tab.

Plain Text	Parameter Name	User Configurable	Notes
Originators			
Application Connection Id	ORIAPPCONNID[1..48]	No	Initiator's Application Connection ID.
Connection State	ORICONNSTATE[1..48]	No	Initiator's Connection State.
Number Of Initiators Using	ORIMUXED[1..48]	No	Number of initiators using multiplexed connections.
Path	ORIPATH[1..48]	No	Initiator's Connection Path.
Transport Class	ORITCLASS[1..48]	No	Initiator's Transport Class.
Targets			
Application Connection Id	TGTAPPCONNID[1..24]	No	Target's Application Connection ID.
Connection State	TGTCONNSTATE[1..24]	No	Target's Connection State.
Transport Class	TGTTCLASS[1..24]	No	Target's Transport Class.

Viewing ICP Statistics tab

The following table summarizes the parameter data you can monitor on the **ICP Statistics** tab of the configuration form for the selected FTE Bridge block. See [Monitoring status through block configuration form](#) for details on accessing the FTE Bridge block configuration form **ICP Statistics** tab in the **Monitoring** tab.

Plain Text	Parameter Name	User Configurable	Notes
Reset ICP Statistics (Button)	ICPSTATRESET	N/A	Click to reset ICP statistics, when available.
ICP General Statistics			
Open Requests Received	RECVOPENREQ	No	Number of open requests received.
Open Responses	SENDOPENRSP	No	Number of open responses

Operation

Using Control Builder Interface

Plain Text	Parameter Name	User Configurable	Notes
Sent.			sent.
Open Requests Sent	SENDOPENREQ	No	Number of open requests sent.
Open Responses Received	RECVOPENRSP	No	Number of open responses received.
Close Requests Received	RECVCLOSEREQ	No	Number of close requests received.
Close Requests Sent	SENDCLOSEREQ	No	Number of close requests sent.
Close Responses Received	RECVCLOSERSP	No	Number of close responses received.
Close Responses Sent	SENDCLOSERSP	No	Number of close responses sent.
ICP Error Statistics			
Connected Send Errors	CONNSENDERR	No	Number of connected send errors.
Un-Connected Send Errors	UNCONNSENDERR	No	Number of unconnected send errors.
Connection Open Failures	CONNOPENFAIL	No	Number of connection open failures.
Connection Close Failures	CONNCLOSEFAIL	No	Number of connection close failures.
Connection Open Rejects	CONNOPENREJECT	No	Number of connection open rejects.
NAKS Received	RECVNAKS	No	Number of negative acknowledgements (NAKS) received.

Viewing Version tab

The **Version** tab is common to all configuration forms for tagged blocks in Control Builder. If you have a Qualification and Version Control System (QVCS) license, this tab shows current QVCS information for the selected FTE Bridge block. Please refer to the

online help and the Qualification and Version Control System User's Guide for more information about the data on this tab. See [Monitoring status through block configuration form](#) for details on accessing the FTE Bridge block configuration form **Version** tab in the **Monitoring** tab.

Viewing IOMGR Statistics tab

The following table summarizes the parameter data you can monitor on the **IOMGR Statistics** tab of the configuration form for the selected FTE Bridge block. See [Monitoring status through block configuration form](#) for details on accessing the FTE Bridge block configuration form **IOMGR Statistics** tab in the **Monitoring** tab.

Plain Text	Parameter Name	User Configurable	Notes
C300 IOMGR Client IP	IOMGRCLI	No	Shows the C300 IP address to which this FTEB IO manager is connected..
Number of IOM's configured	NUMIOM	No	Specifies the number of Series A IOM's configured to this FTEB block. Note that only 16 IOM's can be configured per FTEB block.
Connection status table			
IO Module Name	IOMNAME	No	Name of the configured IOM
ASA path of the IO Module	IOMASAPH	No	ASA path of the configured module
IOM Connection Status	CONNSTAT	No	Current connection status
Last Open Conn Error	CONNERR	No	Last open connection error status

Viewing Server History tab

The **Server History** tab is common to all configuration forms for tagged blocks in Control Builder. The following table summarizes the parameter data you can monitor on this tab of the configuration form for the selected FTE Bridge block. See [Monitoring status through block configuration form](#) for details on accessing the FTE Bridge block configuration form **Server History** tab in the **Monitoring** tab.



ATTENTION

The configuration settings you make for Server Load Options on the **System Preferences** dialog determines whether or not the data entered on the **Server History** tab is loaded to the Experion Server. See the *Control Building Guide* for information about setting system preferences.

Plain Text	Parameter Name	User Configurable	Notes
Access Levels			
Control Level	SCANCTRLVL	Yes	Indicates Server control level to be associated with this function.
Control Area	SCANAREA	Yes	Indicates the Server control area to be associated with this function.
History Configuration			
Number of History Parameters	HIST.NUMPARAMS	Yes	Defines number of history parameters to be included in History Configuration table.
Parameter		Yes	Valid parameter name for a parameter associated with the given point that is to be collected and stored as historical data at predetermined intervals.
Description		No	Provides a brief description of the entered parameter.
FAST		Yes	Select the Fast type of history collection.
STD		Yes	Select the Standard type of history collection
EXTD		Yes	Select the Extended type of history collection

Plain Text	Parameter Name	User Configurable	Notes
Gating Parameter		Yes	Optional gating parameter to define conditions under which data for this parameter should be collected.
Gate State		Yes	Defines gate state for configured gating parameter.
Create New or Edit Existing Server Scripts (Button)		N/A	Launch the Server scripting configuration utility.

Viewing Server Displays tab

The **Server Displays** tab is common to all configuration forms for tagged blocks in Control Builder. The following table summarizes the parameter data you can monitor on this tab of the configuration form for the selected FTE Bridge block. See [Monitoring status through block configuration form](#) for details on accessing the FTE Bridge block configuration form **Server Displays** tab in the **Monitoring** tab.



ATTENTION

The configuration settings you make for Server Load Options on the **System Preferences** dialog determines whether or not the data entered on the **Server Displays** tab is loaded to the Experion Server. See the [Control Building Guide](#) for information about setting system preferences.

Plain Text	Parameter Name	User Configurable	Notes
Point Detail Display	SCANPNTDTL	Yes	By default, a Display template is already entered into Point Detail Display box (for example, sysDtIFTEB.dsp). This template can be used for creating your own display or it can be used as is, provided that your function

Operation
Using Control Builder Interface

Plain Text	Parameter Name	User Configurable	Notes
			block name matches name built into detail display that is supplied as a template.
Group Detail Display	SCANGRPDTL	Yes	By default, a Display template is already entered into the Group Detail Display box (for example, sysGrpFTEB.dsp). This template can be used for creating your own display or it can be used as is, provided that your function block name matches name built into detail display that is supplied as a template
Associated Display	SCANASSOCDSP	Yes	Name of the Server display to be associated with this function block.
Trends			
Number of Trends	TREND.NUMPARAMS	Yes	Defines the number of trend parameters to be included in the Trends Configuration table.
Trend #		Yes	Defines Trend number to be associated with this trend parameter
Pen		Yes	Defines color of pen that will be used to trace assigned parameter on Station Trend display.
Trend Parameter		Yes	Valid parameter name for a parameter associated with given point that is configured for history collection.
Description		No	Provides a brief description of the entered parameter.

Plain Text	Parameter Name	User Configurable	Notes
Groups			
Number of Groups	GROUP.NUMPARAMS	Yes	Defines the number of group parameters to be included in Groups Configuration table.
Group #		Yes	Defines Group number to be associated with this group parameter.
Pos #		Yes	Defines number of position configured parameter will occupy in the Station Group display.
Group Parameter		Yes	Valid parameter name for a parameter associated with the given point that is configured in the system.
Description		No	Provides a brief description of the entered parameter.

Viewing Control Confirmation tab

The **Control Confirmation** tab is common to all configuration forms for tagged blocks in Control Builder. If you have an optional Electronic Signature license, you can configure electronic signature information for the tagged block through this tab on the block's configuration form in Control Builder. Please refer to the online help and the *Server and Client Configuration Guide* for information about the data on this tab.

The Electronic Signature function aligns with the identical Electronic Signatures function that is initiated through Quick Builder and Station for Server points. When this block is loaded to a controller, its control confirmation configuration (electronic signatures) is also loaded to the Server. This means you can view the control confirmation configuration for this tagged object in Station and make changes to it. If you make changes through Station, you must initiate an **Upload** or **Upload with Contents** function through the **Controller** menu in Control Builder for the object in the **Monitoring** tab to synchronize changes in the Engineering Repository Database (ERDB).

Viewing Identification tab

The **Identification** tab is common to all configuration forms for tagged blocks in Control Builder. The following table summarizes the parameter data you can monitor on this tab of the configuration form for the selected FTE Bridge block. See [Monitoring status through block configuration form](#) for details on accessing the FTE Bridge block configuration form **Identification** tab in the **Monitoring** tab.

Plain Text	Parameter Name	User Configurable	Notes
Name	NAME	Yes	Unique block name consisting of up to 16 characters to identify the block. At least one character in the name must be a letter (A-Z).
Description	DESC	Yes	Descriptive text appears on detail and group displays to uniquely describe this particular function block
Block Comment 1	BLCKCOMMENT1	Yes	Comment to be associated with this block consisting of up to 40 characters.
Block Comment 2	BLCKCOMMENT2	Yes	Comment to be associated with this block consisting of up to 40 characters.
Block Comment 3	BLCKCOMMENT3	Yes	Comment to be associated with this block consisting of up to 40 characters.
Block Comment 4	BLCKCOMMENT4	Yes	Comment to be associated with this block consisting of up to 40 characters.
Library		No	Identifies Control Builder Library that is source of template.
System Template		No	Identifies System Template that is source for this block.
Base Template		No	Identifies Base Template that is used for this block.

Plain Text	Parameter Name	User Configurable	Notes
Created By	CREATEDBY	No	Identifies user who created block, if operator security is implemented. Otherwise, may just show Default login.
Date Created	DATECREATED	No	Shows date and time template was created. If this block is in Version Control System, shows date and time initial version of template was created.
Last Modified By	MODIFIEDBY	No	Identifies user who made last modifications to block, if operator security is implemented. Otherwise, may just show default login. If this block is in Version Control System, modifications apply to last version of block.
Date Last Modified	VERSIONDATE	No	Shows date and time last modification was made to block's configuration. If this block is in Version Control System, modification date and time applies to last version of block.

Operation

Using Network Tools (NTools) Utility

Using Network Tools (NTools) Utility

About NTools

The NTools utility lets you view the online status of the chassis mounted hardware. It lets you quickly confirm the firmware revision levels and slot locations of all modules. It supports both ControlNet and Ethernet communications media.



REFERENCE - INTERNAL



Refer to the *Control Hardware Troubleshooting and Maintenance Guide* for more information about the NTools utility.

Launching NTools in Ethernet mode

Considerations

If you are running R210 or greater software, you launch NTools through Configuration Studio. On the **Configuration Explorer** tab, click the **Control Strategy** icon and click **Maintain control system firmware** selection in the **I/O and Network Maintenance** box. In this case, skip Steps 1 and 2 in the following procedure.

Use the following procedure to launch NTools in the Ethernet mode.

Step	Action	Result
1	On the taskbar, Click the Start button, and then click Run .	Opens the Run dialog.
2	In Open box, type <code>ntools -e -u</code> . Click the OK button	<ul style="list-style-type: none">• Launches Network Tools utility in Ethernet mode (-e) with ability to update firmware versions (-u).• Opens Network Tools dialog with warning message.
3	Click the OK button.	Acknowledge the warning about monitoring through Control Builder.
4	On the toolbar, click the Resume  button.	Starts the network scan.
5	If this is the initial launch of NTools, click the Settings  button.	Opens the Settings dialog.

Step	Action	Result
6	<p>Select the desired scanning options. The defaults are:</p> <ul style="list-style-type: none"> • Delay between scans (seconds) - 2 • Periodic (automatic) - selected • Enable mode version/revision checking - checked • Enable ControlNet Parameter checking – checked <p>Click the OK button.</p>	Adjust scanning to your requirements.
	<p>ATTENTION</p> <p>You must create a FTE Bridge block in Control Builder before you can view it in the Network Tools (NTools) utility.</p>	
7	Click the first FTEB icon under the Desktop tree.	<ul style="list-style-type: none"> • If this is the initial NTools launch, the Settings dialog opens. Go to the next Step. • If this is not the initial NTools launch, go to Step 9.
8	Fill in the appropriate data for the Local and Remote chassis configurations in your network associated with the given FTE Bridge module. Click the OK button.	Closes Settings dialog and defines your system configuration for viewing.
9	Once the graphic representation of the chassis appears in the Detail pane, individual modules can be selected, which results in the applicable menu commands becoming available.	Lets you view hardware details and confirm firmware revision levels for modules installed in the chassis. Refer to the <i>Network Tools Help</i> for more information about menu commands.
10	Click NetworkTools menu and then click Exit	Closes the NTools utility.
11	This completes the procedure.	Go to the next Section.

Using Station Displays

Viewing Detail or Group displays

The Experion Server Station application includes pre-configured Detail and Group displays for FTE Bridge blocks. These displays are default entries for the Point Detail Display (sysDtlFTEB.dsp) and Group Detail Display (sysGrpFTEB.dsp) parameters on the Server Displays tab of the FTE Bridge block configuration form. Once you load a FTE Bridge block, you can begin monitoring the Detail displays through Station. The Detail displays provide convenient access to the same information found on the FTE Bridge block configuration form tabs in Monitoring mode.



REFERENCE - INTERNAL

Please refer to the *Operator's Guide* for detailed information about calling up, navigating, and viewing Station displays.

Viewing Event Summary display

Like the Details displays, the Station Alarm and Event Summary displays support integration of FTE Bridge module generated alarms and events through the Network Diagnostic Manager (NDM). The configured FTE Bridge block tag will be used to identify the FTE Bridge module generating the event.

FTE Bridge Redundancy Operation Considerations

About redundancy

If you have redundancy compliant hardware, you can implement redundant CPM/IOLIM/FIM operation through a Redundant Chassis Pair (RCP). A RCP consists of two chassis which include identical redundancy compliant modules in matching slot positions within their given chassis. The following figure shows a typical hardware configuration for a RCP that includes a Control Processor Module (CPM) and a Fieldbus Interface Module (FIM). The RCP does not need CPMs to support FIM redundancy. It does need one pair of Redundancy Modules (RMs) though.

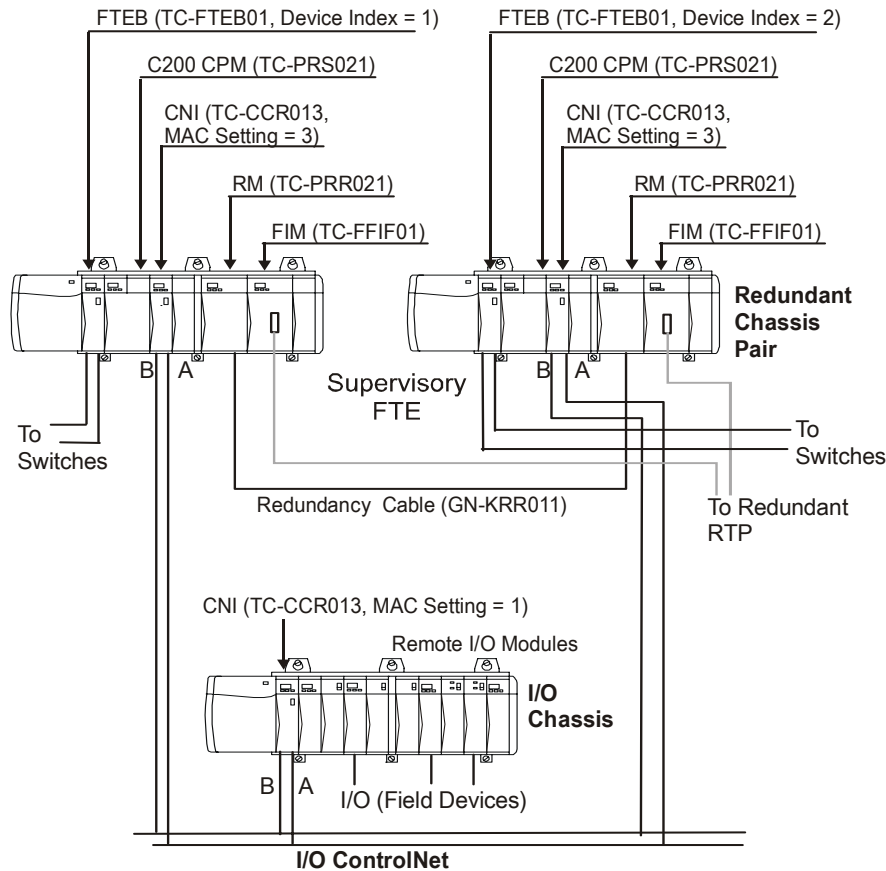

Figure 5 Typical RCP setup in 10-slot chassis.

Operation

FTE Bridge Redundancy Operation Considerations

RM based redundancy

Redundancy Modules in a Redundant Chassis Pair (RCP) configuration provide redundant functionality. The RCP does this by providing a pair of chassis, so a component failure in one chassis switches the handling of the assigned functions to the other chassis. This is considered a dual redundant system, which is characterized by the following two main redundancy states.

- Primary — Refers to the chassis executing the assigned control functions.
- Secondary — Refers to the chassis in some state of readiness to assume the responsibilities of the Primary.



REFERENCE - INTERNAL

Please refer to the *Controller Redundancy Functionality* section in the *Control Builder Components Theory* for more information about Controller redundancy.

Switchover and Secondary readiness

A switchover describes the process where a Secondary chassis assumes the Primary state, and the Primary chassis assumes the appropriate Secondary state of readiness, depending upon what triggered the switchover. A switchover can be triggered immediately upon the detection of a fault in the Primary or upon the receipt of an operator command.

The ability of a Secondary chassis to take over the assigned control functions of the Primary depends upon which one of the following readiness states reflects its current state.

If Secondary Chassis State is . . .	Then, the Secondary Chassis . . .
Disqualified	Cannot assume the Primary state. This is a state of non-readiness.
Synchronizing	Cannot assume the Primary State. In this state, the Secondary chassis is copying database information from the Primary.

If Secondary Chassis State is . . .	Then, the Secondary Chassis . . .
Synchronized	Can assume the Primary state upon switchover. In this state, the database in the Secondary is aligned with the database in the Primary. The Secondary closely tracks database changes to maintain its synchronization with the database of the Primary. Otherwise, the Secondary will revert to a Disqualified state.

Failure conditions and switchover

The following table identifies failure conditions that result in a switchover and those that do not.



ATTENTION

When any failure that results in a switchover occurs in a Secondary, the Secondary chassis loses synchronization.

In addition to the failure conditions, these events are reported as diagnostic notifications:

- Loss of view of redundant partner on H1 network (applies to FIM link).
- Loss of private path connection from Primary to Secondary (lonely event).

Failure Conditions That Result in a Switchover	Failure Conditions That Do Not Result in a Switchover
Power to Primary chassis fails.	One or both fieldbus H1 cables fail.
Integrated Control Protocol (ICP) backplane in primary chassis fails	One or both fieldbus H1 network conditioners fail.
Any module in Primary chassis fails.	The 24-Volt power supply fails.
Both FTE links to Primary FTE Bridge module are lost, and the secondary module has at least one healthy link	One FTE link to Primary FTE Bridge module is lost. The secondary has both links healthy.
Primary FIM's connection to Redundant Remote Terminal Panel fails.	

Operation

FTE Bridge Redundancy Operation Considerations

FTE Bridge switchover considerations

For FTE Bridge modules in a redundant chassis pair, the primary FTE Bridge module does not fail, if it loses communication with both FTE links. In this case, the primary FTE Bridge module initiates a switchover request to the Redundancy Module to switch control to the secondary chassis, assuming it is in a qualified state. The following are some considerations associated with a FTE Bridge module initiated switchover.

For this Switchover Consideration . . .	FTE Bridge Redundancy Operation . . .
Device Index number	Does not transition the Device Index for the primary FTE Bridge module to the secondary FTE Bridge module. The Device Index stays with the physical FTE Bridge module.
MAC Addresses	Does not transition the MAC addresses for the FTE links on the primary FTE Bridge module to the secondary FTE Bridge module. The MAC addresses stay with the physical FTE Bridge module.
IP Address	Does swap IP addresses for primary and secondary FTE Bridge modules during switchover as follows. <ul style="list-style-type: none">• During initial synchronization, primary and secondary FTE Bridge modules exchange their IP addresses over the private redundancy link. This is for verification purpose only, since the odd-even convention allows both modules to determine their partner's address based on their own address.• During switchover or swap, both primary and secondary FTE Bridge modules replace their current IP address with their partner's IP address. This puts redundant pair into transient state in which peer modules are temporarily unable to communicate with either one of them, since their address tables are no longer valid due to the IP address

For this Switchover Consideration . . .	FTE Bridge Redundancy Operation . . .
	<p>swap.</p> <ul style="list-style-type: none"> • After IP address swap, both primary and secondary FTE Bridge modules construct Address Resolution Protocol (ARP) request packets with updated IP-to-Ethernet address mapping and broadcast them on the network. Upon reception of ARP packets, peer nodes update their address tables.



ATTENTION

The swapping of IP addresses is transparent to the higher-level protocols such as Transmission Control Protocol (TCP) or User Datagram Protocol (UDP).

- TCP packets sent to either primary or secondary FTE Bridge module during switchover will be re-tried. Once retry limit is exceeded, connection breaks and gets re-established by application based on updated address information.
- UDP packets sent to either primary or secondary FTE Bridge module during switchover and before client address table is updated will be lost.

Operation
FTE Bridge Redundancy Operation Considerations

Service

Maintenance considerations

Periodic checks

Check the front-panel indicators periodically to be sure all segments of the 4-character display and the light emitting diodes (LED) are working. If segment or LED is not lit or has dimmed, you must replace the FTE Bridge module, since front-panel indicators are not field replaceable.

About removal and insertion under power



CAUTION

While control hardware modules are designed to permit removal and insertion under power (RIUP) without damaging the module, Honeywell recommends that you do **not RIUP** any module in an Experion control system since it may cause an indeterminable upset in the process.



WARNING

Unless the location is known to be non-hazardous, as determined by a combustible gas detector, do **not**:

- connect or disconnect cables,
 - connect or disconnect Removable Terminal Blocks (RTBs), and
 - remove or insert modules under power.
-

Remove and replace FTE Bridge module TC/TK-FTEB01



CAUTION

We recommend that you proceed with **extreme caution** whenever replacing any component in a control system. Be sure the system is offline or in a safe operating mode.

Component replacements may also require corresponding changes in the control strategy configuration through Control Builder, as well as downloading appropriate data to the replaced component.

Use the following procedure as a guide for removing and replacing a FTE Bridge module. This procedure assumes that Control Builder is running.

Service

Maintenance considerations

Step	Action	Result
1	On the Project tab In Control Builder, double click the icon for the FTE Bridge block that represents the FTE Bridge module to be replaced.	Opens SYSTEM:FTEB Block, XXXXX-Parameters [Project] configuration form. Where XXXXXX equals the assigned name.
2	On the Main tab, record the Image Version and Device Index number listed for reference. Click the Cancel button.	Records data for future reference and closes the form.
3	Is the FTE Bridge Module to be replaced installed in a non-redundant chassis configuration or in a redundant chassis pair configuration?	<ul style="list-style-type: none">• If answer is non-redundant chassis, go to Step 5.• If answer is redundant chassis pair, go to Step 4.
4	If FTE Bridge module to be replaced is currently running as the Primary, initiate a switchover to make it the secondary.	Be sure the FTE Bridge module to be replaced is functioning as the secondary, so power to the chassis can be turned off. Skip Step 5 and go to Step 6.
5	Put the Controller in its idle state and be sure the backup battery is functioning.	Prepare the non-redundant Controller chassis for shutdown.
6	Flip the switch on the chassis power supply to the Off position.	Remove power from the chassis.
7	Open the front-panel door and unplug the primary and secondary cable connectors from the sockets on the module.	Prepare module for removal.
8	Push in the top and bottom locking tabs and pull the FTE Bridge module from its chassis slot	Remove the module from the chassis.

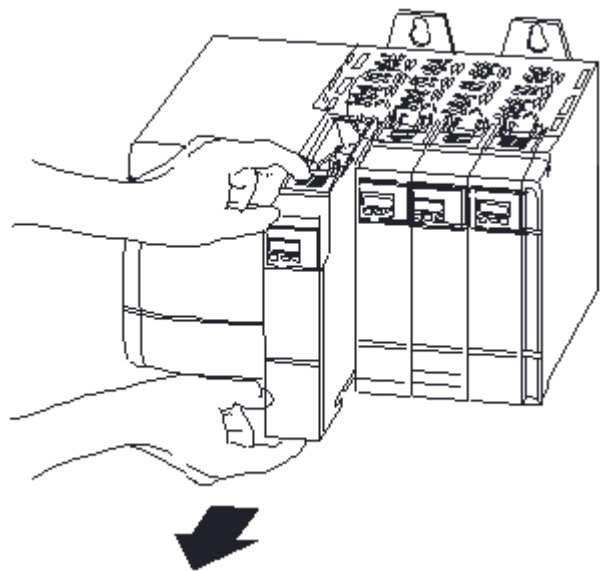
		
<p>9</p>	<ul style="list-style-type: none"> • Note if cable shield ground jumpers are installed or not. See Checking cable shield ground jumper for more information. • Confirm that Device Index number set on BCD rotary switches on the module agrees with the one recorded in Step 2. See Setting unique Device Index for more information 	<p>Confirm settings on the removed module.</p>
<p>10</p>	<p>On the new FTE Bridge module, be sure the cable shield ground jumpers and BCD rotary switches (Device Index) settings match those on the removed module.</p>	<p>Make sure settings on the new module match those on the removed module.</p>
<p>11</p>	<p>Align the module's circuit board with the top and bottom chassis guides for the slot just vacated by the removed module.</p>	
<p>12</p>	<p>Slide the module into the chassis, until the module's locking tabs "click" into position. The module is fully installed when it is flush with the power supply or</p>	

Service

Maintenance considerations

	other installed modules.	
13	Open the front-panel door, connect yellow and green FTE cable connectors to applicable sockets on the module. See Attaching FTE cables for more information. Close the front-panel door.	Connect FTE link cables.
14	Be sure the BOOTP Server service is started. See Checking status of BOOTP server service for more information.	Confirm that BOOTP Server is running.
15	Flip the switch on the chassis power supply to the On position.	Restore power to the chassis.
16	Monitor the front-panel 4-character display to confirm that the module receives its IP address. See Applying power to FTE Bridge Module for more information	Confirm that module is operating.
18	Use the Network Tools utility to check that firmware revision of the new module matches the one recorded in Step 2. See Launching NTools in Ethernet mode for more information.	<ul style="list-style-type: none">• If firmware revision is correct, go to Step 17.• If firmware revision is not correct, go to the Updating FTE Bridge module firmware section and then return to Step 17.
17	If you need to replace the other FTE Bridge module in a redundant chassis pair, wait for the primary and secondary chassis to synchronize and then repeat this procedure following the steps for a redundant chassis pair.	Replace both modules in a redundant chassis pair.
18	This completes the procedure	Return to normal operation.

Updating FTE Bridge module firmware



ATTENTION

If the FTE Bridge module is not installed and pre-configured by the factory, users must load the FTE Bridge module's firmware to make it fully operational. This is also true for any replacement FTE Bridge module ordered separately from the factory.

Use the following procedures to update the firmware revision in a FTE Bridge module.



TIP

If you have updated firmware in other Experion chassis-mounted modules, you will find that this procedure is almost identical.

Checking firmware status

Step	Action	Result
1	If chassis is not powered, flip the switch on the chassis power supply to the On position.	Applies power to the chassis and installed modules initiate their "boot" routines.
2	Wait a few minutes for the modules to reach their normal operating states. Check the 4-Character LED display on the FTE Bridge module.	<p>If the Device Index number and OK or BKUP are sequencing in the FTE Bridge module display, the module is operating and contains some version of firmware. In this case, go to the next procedure Checking firmware version.</p> <p>If RDY appears in the FTE Bridge module display, go to the procedure Loading Boot code</p> <p>If ALIV appears in the FTE Bridge module display, go to the procedure Loading Personality image.</p>
3	This completes the FTE Bridge module firmware status check.	Go to the next appropriate procedure.

Checking firmware version

Step	Action	Result
1	Launch Network Tools. See Launching NTools in Ethernet mode for more information.	Opens Network Tools utility.
2	<ul style="list-style-type: none"> Click the OK button to acknowledge the message prompt. Click the Resume button  in the toolbar. 	NTools begins scanning the network for installed components. Detected nodes will appear under the Desktop directory.



Service

Maintenance considerations

	<p>ATTENTION</p> <p>You must load a FTE Bridge block or have a ControlNet Interface (CNI) module installed in a chassis before you can view other installed but not loaded FTE Bridge modules in the Network Tools (NTools) utility.</p>	
<p>3</p>	<p>Click the node icon.</p>	<p>Graphic representation of the chassis for the selected node appears in the Detail pane.</p>
<p>4</p>	<p>Check the boot version (BV) and application (personality) version (AV) listed on the face of the FTE Bridge module (FTEB01) graphic.</p>	<p>If the version numbers shown are colored green, they are the correct ones for your current system software version. If they are colored red, they need to be updated.</p>
<p>5</p>	<ul style="list-style-type: none"> • If firmware versions are correct (green), click NetworkTools->Exit. • If firmware versions are wrong (red), go to the next sub-procedure <i>Loading Boot code</i> to continue. 	<ul style="list-style-type: none"> • Closes the utility and you can quit this procedure. • Continue with the next sub-procedure.

Loading Boot code

This procedure assumes that you have launched NTools and determined that the FTE Bridge module firmware needs to be updated or the FTE Bridge has started up in the RDY mode.

Step	Action	Result
<p>1</p>	<p>Click the FTE Bridge module (FTEB01) graphic in the chassis representation in the Detail pane.</p>	<p>A red box appears around the graphic to show that it is selected.</p>
<p>2</p>	<p>Click the Flash button  in the toolbar.</p>	<p>Opens Warning! Use Extreme Care dialog.</p>
<p>3</p>	<p>Click the Yes button to acknowledge that the system is Offline.</p>	<p>Opens Please Confirm Changes dialog.</p>
<p>4</p>	<p>Click the Yes button to acknowledge that it is okay to shutdown the FTE Bridge module.</p>	<p>Initiates shutdown and reboot of the FTE Bridge module and calls up the Open dialog.</p>
<p>5</p>	<ul style="list-style-type: none"> • In the Look in box, click the  arrow button to navigate to this directory location c:\Program 	<p>Opens Please Confirm Changes dialog. This illustration is for example purposes only</p>

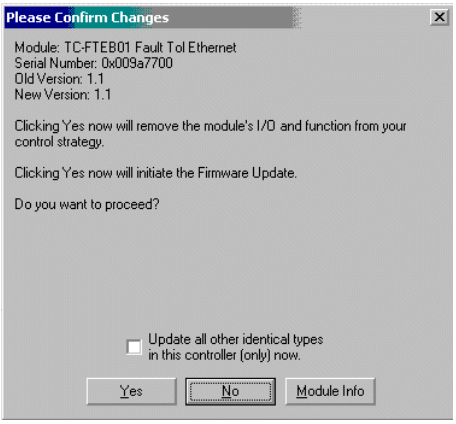
	<p>Files\Honeywell\Experion PKS\Engineering Tools\system\firmware\FTEB, if required.</p> <ul style="list-style-type: none"> Click fteboot.nvs file so it appears in the File name box. Click the Open button. 	
6	Click the Yes button to acknowledge that you want to proceed with the update. (Note that RDY should appear in the FTE Bridge module display)	<ul style="list-style-type: none"> Initiates firmware load. LOAD appears in the FTEB display. Progress of the load is tracked in the status bar.
7	Wait for the load to complete and the FTE Bridge module to reboot to its ALIV state.	NetworkTools message appears.
8	Click the OK button to acknowledge that the update completed with no errors.	Wait for the NTools to complete its next scan.
9	Check that the updated boot version (BV) now appears on the FTE Bridge module graphic in green.	Confirm that load completed successfully.
10	This completes the procedure.	Go to the next procedure Loading Personality image to continue the firmware update.



Loading Personality image

This procedure assumes that you have just completed the previous procedure or the FTE Bridge has started up in the ALIV mode.

Step	Action	Result
1	With FIM graphic still selected, click 	Opens Warning! Use Extreme Care dialog.

Service

Maintenance considerations

	button.	
	ATTENTION Depending on when this function is initiated, you may be asked to confirm the changes and the FTE Bridge module will be rebooted before you can access the Open dialog	
2	Click the Yes button to acknowledge that system is still Offline.	Opens the Open dialog. This illustration is for example purposes only.
3	<ul style="list-style-type: none">In the Look in box, click the  arrow button to navigate to this directory location c:\Program Files\Honeywell\Experion PKS\Engineering Tools\system\firmware\FTEB, if required.Click ftbrex.nvs file so it appears in the File name box. Click the Open button.	Opens the Please Confirm Changes dialog.
4	Click the Yes button to acknowledge that you want to proceed with the update.	<ul style="list-style-type: none">Initiates the firmware load. LOAD appears in the FTE Bridge module display.Progress of the load is tracked in the status bar.
5	Wait for load to complete and the FTE Bridge module to reboot to its normal run state.	NetworkTools message appears.
6	Click the OK button to acknowledge that the update completed with no errors.	Wait for NTools to complete its next scan.
7	Check that the updated application (Personality) version (AV) now appears on the FTE Bridge module graphic in green.	Confirm that load completed successfully.
8	This completes the FTEB Bridge module firmware update.	Go to the next appropriate section.

Spare parts

The FTE Bridge module is not field repairable and the only replacement part is the module itself. The following table lists the recommended spares based on the number of modules installed.

Model Number	Recommended Spares	
	<i>Per 10</i>	<i>Per 100</i>
TC-FTEB01 (uncoated)	1	5
TK-FTEBO1 (coated)	1	5

Configuration changes and migration scenarios

Changing base IP address

If you must change your base IP address, use the following procedure as a guide. The following procedure assumes that you are logged onto Control Builder with the necessary security level to implement control strategy changes and you are familiar with using Control Builder to create and edit control strategies.

Step	Action
1	On the Monitoring tab, inactivate and delete any and all devices.
2	On the Tools menu, click System Preferences to call up the dialog.
3	On the System Preferences dialog, click the Embedded FTE tab.
4	Click the Edit network parameters check box to select it.
5	Key in the new base IP address in the Base IP Address field.
6	If applicable, change Subnet Mask and Default Gateway as well as SNTP Primary Server and Secondary Server addresses.
7	Click the OK button to close the dialog and save the changes. If applicable, follow on-screen prompts to correct any errors. Otherwise, click the OK button to acknowledge the Control Builder warning message.
8	Restart any remote Control Builder applications.
9	Reboot any embedded device that already received its IP address from the previous network configuration.

Service

Configuration changes and migration scenarios

Step	Action
10	Reload your control strategy and continue normal operation.

Changing the Device Index or slot number for a configured FTE Bridge module

If you want to change the Device Index number or slot location of an existing, configured FTE Bridge module, use the following procedure as a guide. The following procedure assumes that you are logged onto Control Builder with the necessary security level to implement control strategy changes and you are familiar with using Control Builder to create and edit control strategies.

Step	Action	Result
1	Is your control strategy loaded and running?	If the answer is Yes , go to the next Step. If the answer is No , go to Step 4.
2	On Monitoring tab, inactivate Control Execution Environment (CEE) and associated Control Modules, Sequential Control Modules, and I/O Modules for all Controllers assigned to the FTE Bridge module targeted for change. Do the same for any assigned Fieldbus Interface Modules (FIMs) and links, and I/O Link Interface Modules (IOLIM) and links.	You must inactivate control strategy components before you can delete them.
3	On Monitoring tab, delete all control strategy components associated with FTE Bridge block and then delete the FTE Bridge block	You must delete control strategy components from Monitoring tab before you can unassign components in the Project tab.
	TIP <ul style="list-style-type: none">It may be helpful to initiate a Project Tree Charts printout through the Print command on the File menu before you unassign and delete components in the Project tab.If you have a Qualification and Version Control System license, there will be additional steps required to check out a component before you can modify it in Control Builder.	
4	On Project tab, unassign all container type blocks, I/O modules, and devices from their respective Control Processor Module (CPM), FIM, and/or IOLIM.	You must unassign components before you can delete a CPM, FIM, or IOLIM block.

Step	Action	Result
5	On Project tab, delete CPMs, FIMs, and IOLIMs associated with the FTE Bridge module, and then delete the FTE Bridge block.	You must delete controllers, so you can configure them for association with the changed FTE Bridge module.
	<p>ATTENTION</p> <p>If you are making changes to a FTE Bridge module in a redundant chassis pair, be sure you make corresponding changes in the partner FTE Bridge module to maintain the proper odd/even Device Index numbering scheme and the installation of modules in matching slot locations.</p>	
6	<ul style="list-style-type: none"> • To change the FTE Bridge module's Device Index number, see Setting unique Device Index for details. • To change the FTE Bridge module's slot position, adapt the steps in the previous procedure Remove and replace FTE Bridge module TC/TK-FTEB01 to install the module in another slot in the chassis. 	Make desired FTE Bridge module Device Index and/or slot position changes.
7	Configure new FTE Bridge block for changed FTE Bridge module. See Creating FTE Bridge module block for details.	Must configure FTE Bridge block before you configure CPM, FIM, and/or IOLIM blocks
8	Configure new CPM, FIM and/or IOLIM blocks for the ones deleted in Step 5.	Associate controllers with changed FTE Bridge module.
9	On Project tab, assign all container type blocks, I/O modules, and devices that were unassigned in Step 4 to their respective Control Processor Module (CPM), FIM, and/or IOLIM.	Re-establish control strategy associations.
10	Load the FTE Bridge block. See Loading FTE Bridge block for details.	FTE Bridge block appears in Monitoring tab.
11	Load the rest of the blocks that make up the control strategy.	All blocks for the control strategy appear in the Monitoring tab.
12	This completes the procedure.	Resume normal operation.

Service

Configuration changes and migration scenarios

Upgrading non-redundant chassis to redundant chassis pair

Use this procedure as a general guide to upgrade an existing non-redundant C200 Controller or Fieldbus Interface Module chassis to be a redundant chassis pair. This procedure assumes that you are aware of the basic requirements for implementing a redundant chassis pair and focuses only on the changes relevant to FTE Bridge modules. See [About redundancy](#) for basic information about a redundant chassis pair.

Step	Action	Result
1	On Monitoring tab, inactivate Control Execution Environment (CEE) and associated Control Modules, Sequential Control Modules, and I/O Modules for all Controllers assigned to the FTE Bridge module targeted for upgrade to a redundant chassis pair. Do the same for any assigned Fieldbus Interface Modules (FIMs) and links, and I/O Link Interface Modules (IOLIM) and links.	You must inactivate control strategy components before you can delete them.
2	On Monitoring tab, delete all control strategy components associated with FTE Bridge block and then delete the FTE Bridge block	You must delete control strategy components from Monitoring tab before you can unassign components in the Project tab.
	TIP <ul style="list-style-type: none">It may be helpful to initiate a Project Tree Charts printout through the Print command on the File menu before you unassign and delete components in the Project tab.If you have a Qualification and Version Control System license, there will be additional steps required to check out a component before you can modify it in Control Builder.	
3	On Project tab, unassign all container type blocks, I/O modules, and devices from their respective Control Processor Module (CPM), FIM, and/or IOLIM.	You must unassign components before you can delete a CPM, FIM, or IOLIM block.
4	On Project tab, delete CPMs, FIMs, and IOLIMs associated with the FTE Bridge module, and then delete the FTE Bridge block.	You must delete controllers, so you can configure them for association with the redundant FTE Bridge module.
5	Flip the power supply switch to Off on the existing non-redundant power supply.	Remove power from the chassis before removing and inserting modules.

Step	Action	Result
6	Remove the FTE Bridge module from the non-redundant chassis and set its Device Index to desired odd number. See Setting unique Device Index for details.	The FTE Bridge module in the existing non-redundant chassis becomes the primary FTE Bridge module in the redundant chassis pair.
7	Install the Redundancy Module in the appropriate slots in the non-redundant chassis.	All modules in redundant chassis pair must be redundancy compliant and installed in matching slot locations.
8	Install the secondary chassis and check that the Device Index number on the FTE Bridge module in this chassis is the next even number following the odd number set for the Primary FTE Bridge module. Also, be sure cable shield jumpers are installed or removed, as required.	Be sure FTE Bridge modules in redundant chassis pair have appropriate odd/even Device Index numbers.
9	Connect the dedicated cable between the Redundancy Modules and connect the FTE cables to the secondary FTE Bridge module. Make any other field connections to the secondary chassis, as required.	Make all network and field connections to modules in the chassis.
10	Configure new redundant FTE Bridge blocks for FTE Bridge modules in redundant chassis pair. See Creating FTE Bridge module block for details.	Must configure FTE Bridge block before you configure CPM, FIM, and/or IOLIM blocks
11	Configure new redundant CPM, FIM and/or IOLIM blocks for the ones deleted in Step 4.	Associate controllers with redundant FTE Bridge modules.
12	Configure new Redundancy Module (RM).	Support redundant chassis pair.
13	On Project tab, assign all container type blocks, I/O modules, and devices that were unassigned in Step 3 to their respective Control Processor Module (CPM), FIM, and/or IOLIM.	Re-establish control strategy associations.
14	Load the FTE Bridge blocks. See Loading FTE Bridge block for details.	FTE Bridge blocks appear in Monitoring tab.
15	Load the rest of the blocks that make up the control strategy.	All blocks for the control strategy appear in the Monitoring tab.

Service

Migrating from ControlNet or Ethernet supervisory network

Step	Action	Result
16	This completes the procedure.	Resume normal operation.

Migrating from ControlNet or Ethernet supervisory network

To convert your existing ControlNet or Ethernet supervisory network to a Fault Tolerant Ethernet supervisory network, you must make a network topology change which requires different hardware than was originally installed with your system. This is not a software migration and requires the clean installation of Experion software. For details about installing Experion software, refer to the *Software Installation and Upgrade Guide*.

Migration from FTE based C200 to C300

You can migrate from FTE-based C200 to C300 and retain the Series A - Chassis I/O associated with the C200 by connecting the C300 to the same FTE segment and installing an FTE Bridge module in the Series A I/O chassis, as show in following figure.

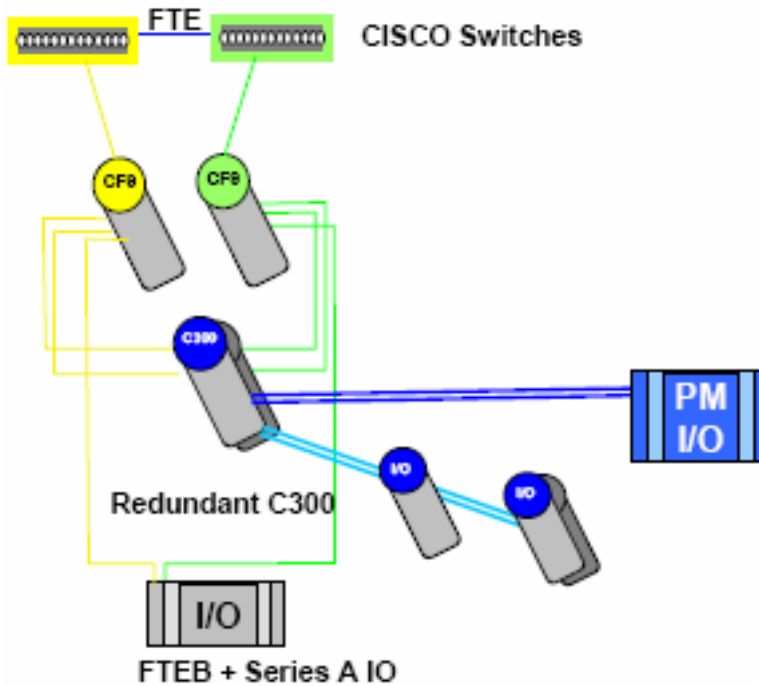

Figure 6 Basic C300 with Series A I/O topology

Prerequisites

- You must take your control system **offline** before starting the supervisory network migration process.
- Your current software and hardware must support at least Experion R300 software. See [Checking software and firmware versions](#).
- You have logged onto Control Builder with the security level required to make control strategy changes.

Considerations

It may be helpful to initiate a **Project Tree Charts** printout through the **Print** command on the **File** menu before you begin.

If you have a **Qualification and Version Control System** license, there will be additional steps required to check out a component before you can modify it in Control Builder.

Checking software and firmware versions

Step	Action
1	On the Project tab, double-click the Control Processor Module (CPM) block icon to open the block's configuration form.
2	On the Main tab, check the Database Release (CURRENTREL) parameter to verify the current Experion software you are running and check the Image Version (IMAGEVER) parameter to verify the current CPM firmware personality loaded in the CPM.
3	Repeat Steps 1 and 2 to verify the Image Version (IMAGEVER) for any FIMs, IOLIMs, ACEs, or other CPMs included in your control strategy.
4	<ul style="list-style-type: none"> • If software and firmware versions are at the Experion R300 software level or greater, go to the next procedure. <p>If software and firmware versions are not at the minimum Experion R300 software level, see the <i>Software Installation and Upgrade Guide</i> to install the required software and firmware.</p>
5	This completes the procedure.

Service

Migration from FTE based C200 to C300

Exporting current database and restoring clean database

Step	Action
1	On Monitoring tab, inactivate Control Execution Environment (CEE) and associated Control Modules, Sequential Control Modules, and I/O Modules for all Controllers in your control strategy. Do the same for any assigned Fieldbus Interface Modules (FIMs), links, and devices; and I/O Link Interface Modules (IOLIM), links, and I/O Processors.
2	On Monitoring tab, delete the target C200 controllers
3	Click the Project tab.
4	On the File menu, click Export .
5	On Export dialog, select all points and types except those for the target CPM200s.
6	To change storage directory location, click the Browse button and navigate to desired Directory location.
7	Click the Export button. The Exporting Data dialog appears to show progress of the action.
8	With database export completed, click the Start button on the taskbar.
9	<ul style="list-style-type: none">Click Programs>Experion Engineering Tools>DB Admin to open the DB Admin utility. Or - <p>If you are running R210 or greater software, you launch the DbAdmin utility through the Configuration Studio. On the Configuration Explorer tab, click the Control Strategy icon and click the Administer the control strategy database selection in the Process Control Strategies box. In this case, skip the next Step, since you logon through Configuration Studio.</p>
10	Logon with user name and password, if required. Click plus + sign for DBAdmin folder to expand it.
11	Click plus + sign for Experion Node folder to expand it.
12	Click ERDB Admin Tasks folder to open Tasks window.
13	On Tasks window, click the Restore Database icon. Acknowledge messages.
14	When Completed successfully message appears, the clean ERDB has been restored. On Console menu, click Exit .
15	This completes the procedure. Go to the next procedure.

Build new C300 controllers

Build new C300 controllers with the same names as the C200 controllers they replace.

Configuring control strategy

Step	Action
1	Configure FTE Bridge block.
2	On Project tab, configure new C300s that are associated with the FTE Bridge module to replace those that were not exported. See the Control Building Guide for details.
3	If applicable, use the File menu New->Type->Fieldbus Device command to create any Fieldbus device templates that were deleted when the clean database was restored. See the Fieldbus Implementation Guide for details.
4	On the File menu, click Import .
5	Click the Browse button and navigate to directory location where you previously stored the database and click the OK button. The database location is listed in the Directory box.
6	Be sure the check box for the Import CEE Assignments is deselected.
7	Click the Select All button.
8	Click the Import button. Track the progress of the import on the Importing Data dialog.
9	When the import is completed. Move/assign the IOMs to the applicable C300/CEEC300 block.
10	Open the IOMs one by one and assign the correct FTE Bridge to each one. Then load the IOMs
11	Load the FTE Bridge block and other control strategy components as you normally would.
12	This completes the migration procedures.

Import/export and on-process migration support

You can use the existing **Import** and **Export** commands provided on the Control Builder **File** menu to import and export a FTE Bridge block as you would any other block. The **Device Index** and slot number configuration for the FTE Bridge block is exported. The base **IP Address** for the FTE Bridge block is not exported, so it can be imported into a different FTE community where it will receive a new **IP Address** based upon that community's base **IP Address**.

The FTE Bridge module supports on-process migration (OPM) in the same way as the IOLIM and FIM modules. The on-process migration utility is a licensed option that was introduced with Experion system R101 software. See the [On-Process Migration Planning Guide](#) for more information.



ATTENTION

- We recommend that you use the ERDB Database (or Server) Migration function of the OPM utility to move hardware definitions like the FTE Bridge modules instead of the Export/Import functions.
 - Use the Export/Import functions to move or copy control strategies (Control Modules and Sequential Control Modules) from one system to another.
-

Troubleshooting

This section lists some possible problems you may encounter in using the FTE Bridge module. The focus is on the FTE Bridge module itself and not the FTE network which has its own diagnostics and report mechanisms.

Module indicators are off	
The 4-character display and all LEDs are off.	
Diagnostic check:	The 4-character display and all LEDs are off.
Cause:	Module is not receiving power.
Solution:	Be sure module is fully seated in the chassis slot. Turn On power supply switch. Be sure power is connected to the power supply

OK LED is off	
The OK LED is off but 4-character display is working.	
Diagnostic check:	The OK LED is off but 4-character display is working.
Cause:	Bad LED
Solution:	Replace the FTE Bridge module. Click Here

FAIL indication	
4-character display is alternately showing FAIL and a code number.	
Diagnostic check:	Refer to the failure codes located in Table 5
Cause:	Internal diagnostics has detected a failed application.
Solution:	Cycle power to the chassis. If error persists, replace the FTE Bridge module. Click Here

ALIV indication	
4-character display is showing ALIV	
Diagnostic check:	4-character display is showing ALIV
Cause:	Personality image has not been loaded to the module.
Solution:	Load the personality image to the Module. Click Here

RDY indication	
4-character display is showing RDY	
Diagnostic check:	4-character display is showing RDY
Cause:	Boot code has not been loaded to the module.
Solution:	Load the boot code to the module. Click Here

-BP- indication	
4-character display is showing –BP-.	
Diagnostic check:	4-character display is showing –BP-.
Cause:	Module has not received its IP Address.
Solution:	Be sure FTE cables are connected to the module. Click Here Be sure BOOTP Server service is running. Click Here

Self-test hang	
4-character display is stuck on a test code (TXXX).	
Diagnostic check:	See the following FTE Bridge Module Test Codes table for list of selftest codes.
Cause:	Module has hung on selftest routine.
Solution:	Cycle power to the chassis. If error persists, replace the FTE Bridge module. Click Here

Cable error indication	
A or B LED is Red.	
Diagnostic check:	A or B LED is Red.
Cause:	FTE cable is not connected.
Solution:	Connect FTE cable to module. Click Here

FTEB not visible to NTools	
FTE Bridge module is not visible in NTools chassis view.	
Diagnostic check:	FTE Bridge module is not visible in NTools chassis view.
Cause:	Chassis does not contain a configured FTE Bridge module or ControlNet Interface module.
Solution:	Load configured FTE Bridge block to module. Click Here

Cannot create FTEB	
Cannot create FTE Bridge block.	
Diagnostic check:	Cannot create FTE Bridge block.
Cause:	Invalid base IP address (0.0.0.0).
Solution:	Configure valid base IP address through Embedded FTE tab on System Preferences dialog. Click Here

Cannot 'ping' FTEB	
FTE Bridge module appears on System Management FTE display but cannot be "pinged"	
Diagnostic check:	FTE Bridge module appears on System Management FTE display but cannot be "pinged"
Cause:	Incorrect address assignment.
Solution:	Be sure DHCP server is not configured to respond to BOOTP requests. DHCP server may assign address in different range. Be sure only Honeywell BOOTP servers bundled with Experion software are on the network. Change Device Index or slot number of FTE Bridge module and retry. Click Here

Table 5 FTE Bridge Module Test Codes

Test Code	Function
T000	Selftest start test
T001	LED check test
T002	Memc initialization test
T003	CPU mask test
ROM Test	
T010	Boot image check test
T011	Loader image check test

Test Code	Function
<i>RAM and Parity Tests</i>	
T020	RAM BR or check test
T021	Lower RAM word access test
T022	Upper RAM word access test
T023	Lower RAM byte access test
T024	Upper RAM byte access test
T025	Lower RAM parity int. test
T026	Lower RAM parity int. test
T030	RAM parity sweep test
T031	RAM sweep time test
T032	RAM retention test
T033	RAM address test
T034	RAM pattern test
T040	Flash burst test
T044	RAM860 address test
T045	RAM860 pattern test
T046	CPU type test
<i>D-Cache Tests</i>	
T050	I Cache function test
T051	I Cache integrity test
T055	D Cache function test
T056	D Cache RAM wrap test
T057	D Cache integrity test
<i>Hardware Status Register and System Control Tests</i>	

Test Code	Function
(The following tests look for improper states of hardware status bits.)	
T060	Stuck watch dog timer pend test
T061	Stuck DC fail test
T062	Stuck IRQ0 test
T063	Stuck ICP timer test
T064	Stuck ICP comm test
T065	Stuck System fail test
T066	System fail assert test
<i>ICP ASIC and Shared RAM Tests</i>	
T100	ICP ASIC initialization test
T101	ICP RAM byte write test
T102	ICP RAM byte parity test
T103	ICP RAM word read test
T104	ICP RAM byte read test
T105	ICP RAM half read test
T106	ICP RAM half write test
T107	ICP RAM half align test
T108	ICP RAM word align test
T109	ICP RAM address test
T110	ICP RAM pattern test
T111	ICP register access test
T112	ICP address echo test
T113	ICP bus lock test
T114	ICP clock run test

Test Code	Function
T115	ICP clock compare test
T116	ICP interrupt test
T117	ICP ASIC RAM parity test
T118	ICP RAM ASIC active test
ICP Tests (The ICP comm interrupt cannot be tested during selftest.)	
T120	DB FPGA load test
T121	DB lower RAM byte test
T123	DB lower RAM parity test
T125	DB lower RAM access test
T127	DB RAM address test
T128	DB RAM pattern test
FTE Bridge Tests	
T130	DB EEPROM interface test
T131	DB PHY interface test
T150	Application image check test
T255	Selftest done test

Honeywell

Honeywell International
Process Solutions
2500 West Union Hills
Phoenix, AZ 85027