

# **Enhanced PLC Gateway Planning, Installation, and Service**

**EP02-500**

---



**Implementation  
EPLC Gateway**

***Enhanced PLC Gateway  
Planning, Installation,  
and Service***

**EP02-500  
Release 500  
CE Compliant  
9/95**

---

# Copyright, Trademarks, and Notices

Printed in U.S.A. — © Copyright 1995 by Honeywell Inc.

Revision 01 – September 15, 1995

While this information is presented in good faith and believed to be accurate, Honeywell disclaims the implied warranties of merchantability and fitness for a particular purpose and makes no express warranties except as may be stated in its written agreement with and for its customer.

In no event is Honeywell liable to anyone for any indirect, special or consequential damages. The information and specifications in this document are subject to change without notice.

## **ACKNOWLEDGEMENTS AND CREDITS**

Allen-Bradley and A-B are trademarks of the Allen-Bradley Company, Inc.

Black Box is a trademark of the Black Box Corporation.

Modicon and Modbus are trademarks of AEG-Modicon.

---

---

## About This Publication

This publication is provided to guide the user in planning, installing, and servicing the Enhanced Programmable Logic Controller Gateway (EPLCG). Only those components unique to the EPLCG are covered in detail. It is not intended to be a substitute for standard LCN Site Planning, System Installation, and Service manuals, which are referenced for further detail.

This publication supports TDC 3000<sup>X</sup> software release 500 and CE Compliant hardware.

Any equipment designated as “CE Compliant” complies with the European Union EMC and Health and Safety Directives. All equipment shipping into European Union countries after January 1, 1996 requires this type of compliance—denoted by the “CE Mark.”

# Standard Symbols

## Scope

The following defines standard symbols used in this publication

### ATTENTION

Notes inform the reader about information that is required, but not immediately evident

### CAUTION

Cautions tell the user that damage may occur to equipment if proper care is not exercised

### WARNING

Warnings tell the reader that potential personal harm or serious economic loss may happen if instructions are not followed

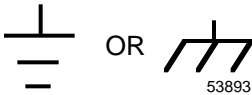

Ground connection to building safety ground

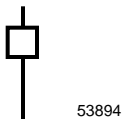

Ground stake for building safety ground



Electrical Shock Hazard—can be lethal



Electrical Shock Hazard—can be lethal

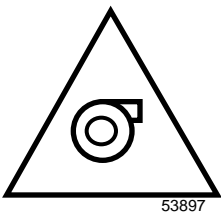

Rotating Fan—can cause personal injury

---

# Table of Contents

---

<b>1</b>	<b>INTRODUCTION</b>
1.1	General Description
1.2	EPLCG Module for EC
1.3	Honeywell Support Services
1.4	Related Publications
<b>2</b>	<b>SITE PREPARATION</b>
2.1	Storage Conditions
2.2	Site Requirements
2.2.1	Dimensions and Weight
2.3	Electrical Requirements
2.3.1	AC Voltage Options
2.3.2	Frequency
2.3.3	Current in Amperes at 120 Vac
2.4	Configurations
2.4.1	MP-NEPLC1 Nonredundant Gateways
2.4.1.1	Nonredundant Configurations
2.4.2	MP-REPLC2 Redundant Gateways
2.4.3	MP-REPLC1 Redundant Gateways with A-B Redundant Comm
2.4.4	Redundant Gateway Configurations
2.5	Limitations
2.5.1	Physical Limitations
2.5.2	Single vs. Multidrop Cabling
2.5.3	Cable Lengths
2.5.4	Direct Connection
2.6	EPLCG to PLC Connections
2.6.1	Modem Usage and Selection
2.6.2	Nonredundant EPLCG Port Connections
2.6.3	Redundant EPLCG Port Connections
<b>3</b>	<b>INSTALLATION</b>
3.1	Unpacking
3.2	Assembly and Cabling
3.2.1	Module Installation
3.2.2	LCN Node Pinning
3.2.3	EPLCI Pinning
3.2.3.1	Ram Clear (J1)
3.2.3.2	Board Revision (TS1)
3.2.3.3	Baud Rate and Parity (TS2)
3.2.3.4	Program Options (TS3)
3.2.4	EC Installation of EPLCI I/O Board
3.2.5	EPLCG Relay Panel Pinning
3.2.5.1	EPLCG Relay Panel for EC
3.2.6	EPLCG Cabling
3.2.7	Port Cabling and Pinning for Modems Using Modbus Protocol
3.2.7.1	Modem Cable
3.2.7.2	Modem Wiring
3.2.7.3	Modem Pinning

---

# Table of Contents

---

3.2.8	Port Cabling for Direct Connection to Modbus Equipment
3.2.9	Port Cabling for Equipment Using Allen-Bradley Protocol
3.2.9.1	Direct Connection to Allen-Bradley Controllers
3.2.9.2	Allen-Bradley CIM Pinning
3.3	Installation Wrap-Up
<b>4</b>	<b>CHECKOUT</b>
4.1	Power-On Tests
4.1.1	Electronics Checks
4.2	Startup
4.3	Communications and Performance Statistics
4.3.1	PLC Error and Retry Counters
4.3.2	Last Error Codes
4.3.3	View Words
4.4	Port Statistics
4.4.1	Subslots Processed Per Second
4.4.2	Number of Messages Transmitted/Second
4.4.3	Number of Messages Received/Second
4.4.4	Number of Bytes Transmitted/Second
4.4.5	Number of Bytes Received/Second
4.4.6	Number of Scan Buffers Processed/Second
4.4.7	Number of Keepalive Buffers Processed/Second
4.4.8	Number of Output Buffers Processed/Second
4.4.9	Firmware Freetime/Second Counters
4.4.10	Number of Unsolicited Buffers Processed/Second
4.4.11	Number of Output FIFO Entries Available
4.5	Digital Input Status Points
4.5.1	Port Status
4.5.2	Best View Failover
4.5.3	Port Output FIFO Overflow
<b>5</b>	<b>Service</b>
5.1	Overview
5.2	Field Adjustment
5.3	General Troubleshooting
5.4	EPLCI Troubleshooting
5.4.1	EPLCI Hardware Indicators
5.4.2	EPLCI Hardware Indicator Troubleshooting Chart
5.4.3	EPLCI System Software Indications
5.4.3.1	Battery Failure
5.4.3.2	Device Failure
5.4.3.3	Data Hiway Port Error Codes
5.5	Spare Parts

## INTRODUCTION

### Section 1

*This section provides an overview of the EPLCG equipment, and lists reference documents available from Honeywell.*

#### 1.1 GENERAL DESCRIPTION

The Enhanced Programmable Logic Controller Gateway (EPLCG) is a new version of the PLCG with added features and improvements. The EPLCG expands the idea of providing an economical method for connecting various Programmable Logic Controllers to your Honeywell TDC 3000<sup>X</sup> system. Its redundant communications option provides two independent communication paths to the PLCs, and it features increased output performance. A new EPLCI board containing new firmware and new I/O hardware for the EPLCG add configurations for additional applications.

This manual guides you through the planning and installation considerations unique to the EPLCG equipment. However, this manual is not intended to be a substitute for the *LCN Site Planning* manual and *LCN System Installation* manual, listed in the standard LCN publications referenced in subsection 1.3 of this manual.

The EPLCG runs under an unmodified HG (Hiway Gateway) software personality. The hardware is similar to HG hardware, contained in a standard TDC 3000 Dual Node module that supports the Local Control Network (LCN). In the EPLCG, the Data Hiway Interface (DHIF) board and its I/O board are replaced with the Enhanced Programmable Logic Controller Interface (EPLCI) board and an EPLCI I/O board. The existing PLCI, PLCI I/O paddle boards, and relay panel will continue to be used for specific applications.

A redundant EPLCG pair is composed of two EPLCG modules equipped as above.

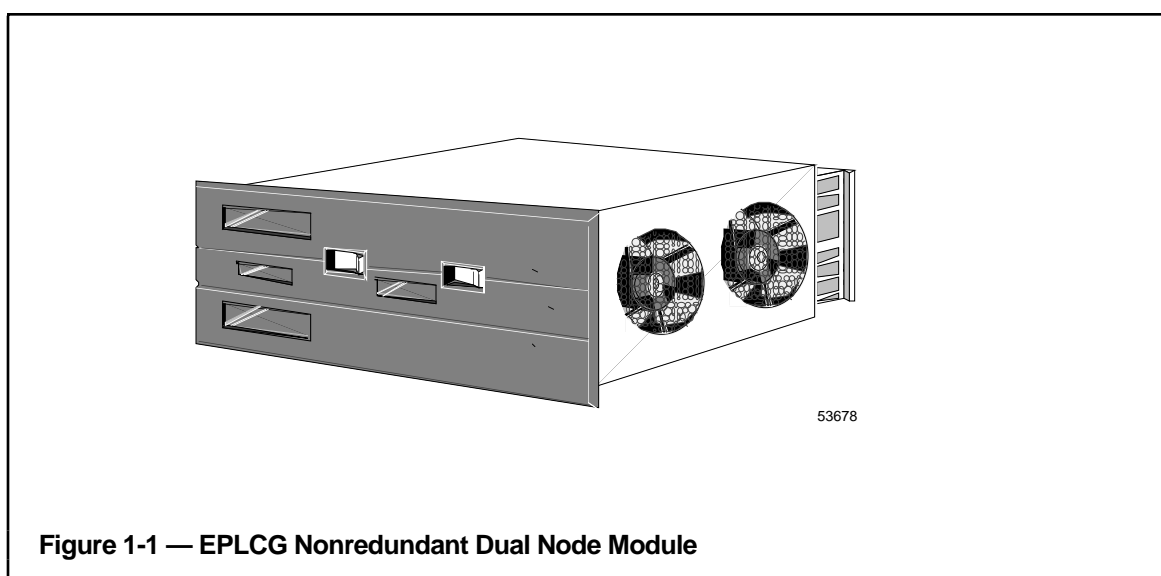

## 1.2 EPLCG MODULE FOR EC

The CE compliant PLCG and EPLCG I/O cage supports the three styles of modules. It supports the nonredundant EPLCG, the redundant PLCG, and the communications redundant EPLCG. The CE compliant modules are capable of holding both the older and newer types of I/O board designs.

The I/O File has been modified to make electrical contact with faceplates attached to the I/O boards. This provides low impedance ground path for the cable shields. The faceplates and the wire mesh covering the fan openings also provide EMI shielding around the module. The module is similar in all other respects.

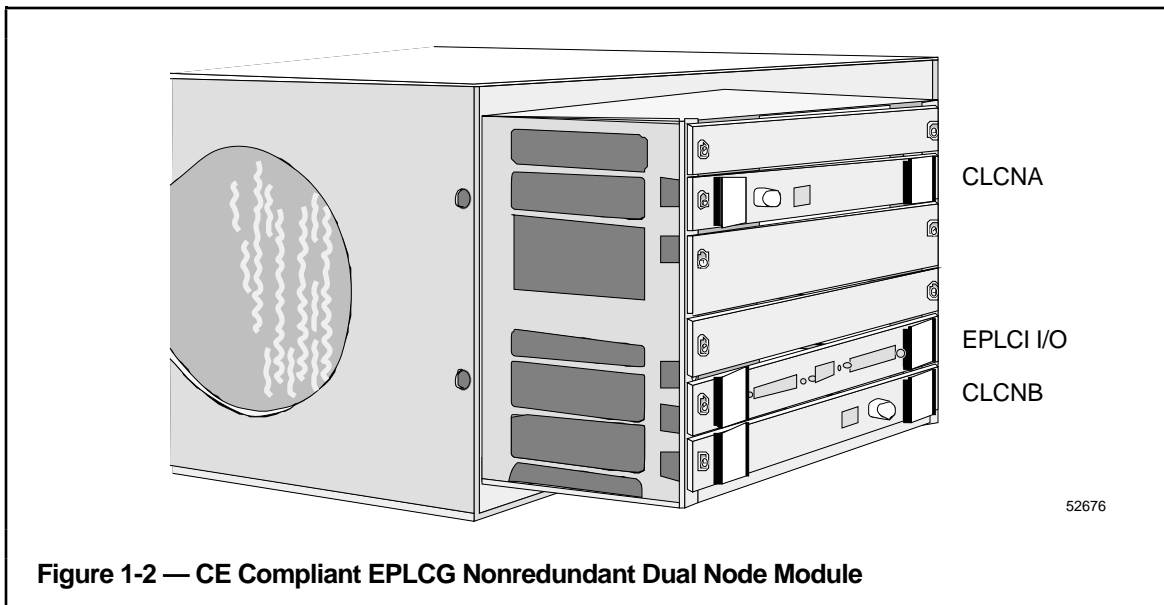

## 1.3 HONEYWELL SUPPORT SERVICES

Optional Installation Support, Field Services, and Technical Support are available during the on-site installation and checkout of TDC 3000<sup>X</sup> system equipment. Honeywell representatives are available to assist in interpreting this manual and to help resolve problems or situations not covered by this manual. A toll-free number (800-822-7673; in Arizona, 602-313-5558) is available for technical assistance.

## 1.4 RELATED PUBLICATIONS

Honeywell's standard documentation is included with the system. The following publications apply to the TDC 3000<sup>X</sup> system and should be referred to as required and available:

<b>Publication Title</b>	<b>Publication Number</b>	<b>Binder Title</b>	<b>Binder Number</b>
<i>Local Control Network Planning</i>	SW02-501	System Site Planning - 1	3020-1
<i>LCN System Installation</i>	SW20-500	LCN Installation	3025
<i>LCN System Checkout</i>	SW20-510	LCN Installation	3025
<i>Hiway Gateway Specification and Technical Data</i>	HG03-500	System Summary - 2	3010-2
<i>Five/Ten-Slot Module Service</i>	LC13-500	LCN Service - 2	3060-2
<i>Dual Node Module Service</i>	LC13-510	LCN Service - 2	3060-2
<i>Maintenance Test Operations</i>	SW11-502	LCN Service - 1	3060-1
<i>Test System Executive</i>	SW13-510	LCN Service - 3	3060-3
<i>Hardware Verification Test System</i>	SW13-511	LCN Service - 3	3060-3
<i>Core Module Test System</i>	SW13-512	LCN Service - 3	3060-3
<i>Process Operations Manual</i>	SW11-501	Operation/Process Operations	3050
<i>EPLCG Specification &amp; Technical Data</i>	EP03-500	System Summary - 2	3010-2
<i>EPLCG Control Functions</i>	EP09-500	Implementation/ EPLC Gateway	3081
<i>EPLCG Implementation Guidelines</i>	EP12-500	Implementation/ EPLC Gateway	3081
<i>EPLCG Parameter Reference Dictionary</i>	EP09-540	Implementation/ EPLC Gateway	3081
<i>EPLCG Forms</i>	EP88-500	Implementation/ EPLC Gateway	3081



## SITE PREPARATION Section 2

*This section provides the following information for the EPLCG: Storage conditions, site requirements, electrical requirements, and configuration information.*

### 2.1 STORAGE CONDITIONS

If the EPLCG is to be placed in storage, follow these environmental constraints:

Temperature	-35° C to +70°C
Humidity (RH)	10% – 80%, max wet bulb 20 – 30°C
Shock*	3.0 g for 10 milliseconds

\* When enclosed in the original shipping container.

Note that the temperature/relative humidity cannot be cycled such that moisture or condensation occurs on the equipment—keep the rate of change less than 6% per hour. These storage and shipping requirements are for one year duration only, provided the equipment is properly packaged and contains an adequate amount of desiccant (moisture removing agent).

### 2.2 SITE REQUIREMENTS

The EPLCG is designed for a Class A General Industrial environment. It must be operated in a temperature environment of 0° – 50°C (32° – 122°F). While operating, components of this system are not designed to withstand greater vibration than 1g.

This equipment is intended for use in a controlled environment. Although TDC 3000<sup>X</sup> equipment will operate at 0 – 50°C, Honeywell recommends a normal environment of 25°C (77°F) with a relative humidity of 40 – 50% to realize maximum life and enhanced reliability.

#### 2.2.1 Dimensions and Weight

The approximate dimensions and weight for each EPLCG dual node module are:

Height	17 cm (7")	Weight	21.5 kg (46 lb)
Width	48 cm (19")		
Depth	61 cm (24")		

## 2.3 ELECTRICAL REQUIREMENTS

The customer selected ac power option is installed in the EPLCG before shipment.

The inrush current to each electronics module is limited to 15 A @ 120 V, 30 A @240 V.

### 2.3.1 AC Voltage Options

120, 220, 240 Vac +10%, -15%

### 2.3.2 Frequency

47 Hz to 63 Hz

### 2.3.3 Current in Amperes at 120 Vac

		Avg	True RMS	Peak	Wattage	BTUs/hr
MP-NEPLC1 — with K2LCN, Nonredundant Module	typical	0.939	1.27	6.99	152.5	520.0
	maximum	1.45	1.94	10.35	198.3	676.2
MP-REPLC1 — with K2LCN, 2 Redundant Modules (Two modules required) Without Relay Panel	typical	1.878	2.54	13.98	305.0	1040.0
	maximum	2.90	3.88	20.70	396.6	1352.4
MP-REPLC2 — with K2LCN, 2 Redundant Modules (Two modules required) With Relay Panel	typical	1.878	2.54	13.98	305.0	1040.0
	maximum	2.90	3.88	20.70	396.6	1352.4

## 2.4 CONFIGURATIONS

Various nonredundant and redundant configurations of the EPLCG connected to PLCs of different manufacture are available. Depending upon certain limitations, the EPLCG can communicate to the PLCs either through short-haul modems or Communication Interface Modules (CIMs). Six different configurations have been defined for the new EPLCG; 2 Nonredundant and 4 Redundant. Some overlap occurs with the existing PLCG products and is noted in the following installation-type descriptions.

### 2.4.1 MP-NEPLC1 NONREDUNDANT GATEWAYS

Both of the nonredundant EPLCG versions use the new EPLCI I/O card, which eliminates the need for the relay panel .

The Type 1 version does not use the Redundant Communications option. Though it is possible to configure this one with a PLCI, EPLCI-resident features will not be available.

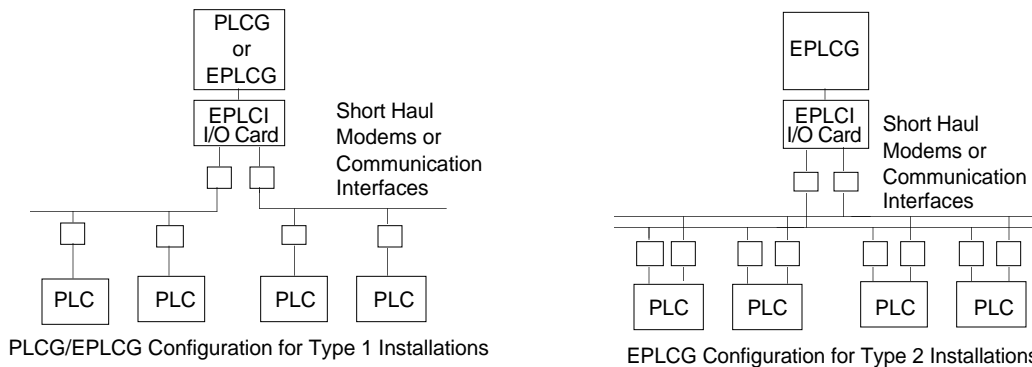

53302

53303

The Type 2 uses the Redundant Communications option. The Redundant Communications option is not supported by a PLCI.

### 2.4.1.1 Nonredundant Configurations

Figure 2-1 shows an EPLCG connected in a Type 1 nonredundant configuration in a dual node module lower node. Each port (ports 1 and 2) may service any number of individual Programmable Logic Controllers up to a Honeywell-supported total of 16 PLCs per EPLCG (up to 64 PLCs can be addressed). See subsection 2.6.2 for examples of nonredundant port cabling configurations.

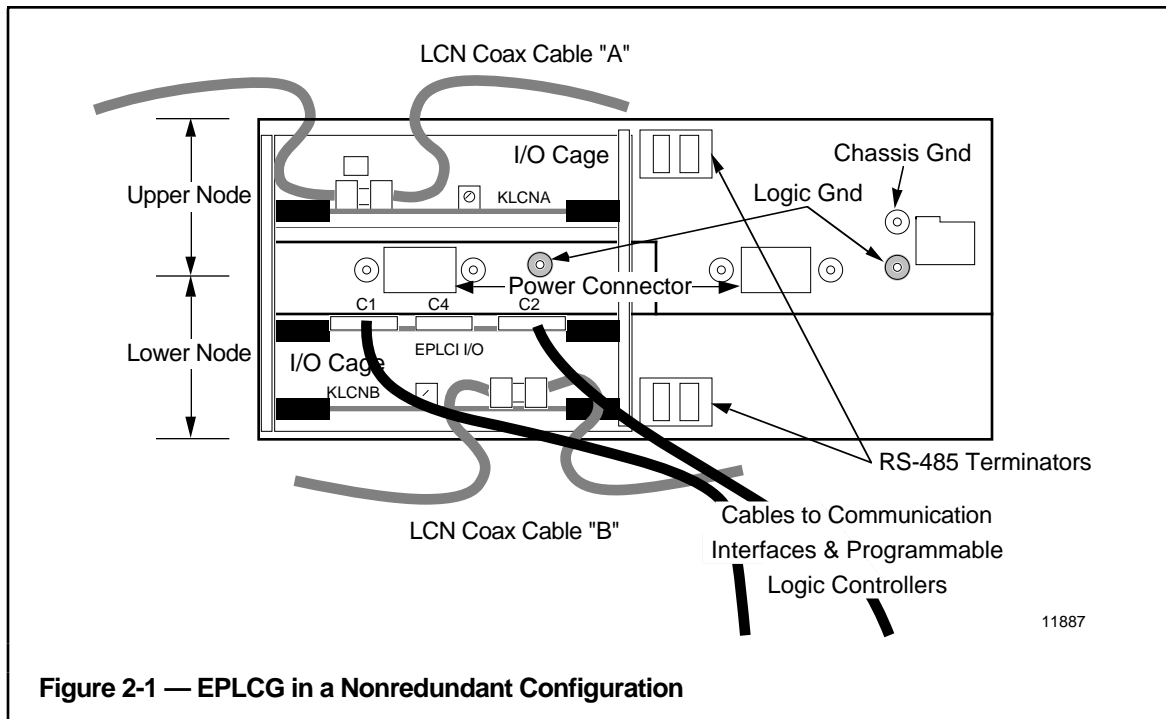

Each port may be configured to either the Modbus or Allen-Bradley (A-B) protocol. That is, in the **nonredundant** EPLCG configuration, you may have one port connected to a Modbus and the remaining port connected to A-B equipment, or both ports configured to the same bus type.

## 2.4.2 MP-REPLC2 REDUNDANT GATEWAYS

The remaining 4 types are redundant EPLCGs; with a Primary gateway and its backup Secondary. The first 2 are configured with PLCI I/O and the high reliability relay panel, not using the Redundant Communications option. In these two, 2 PLCIs can be configured in place of the EPLCIs, with the resultant loss of EPLCI-resident features mentioned above. Please note that the PLCG and EPLCG are NOT compatible for redundant gateways.

Type 3 is used with nonredundant communications, Honeywell or Modbus protocols and Short Haul Modems or Communications Interfaces.

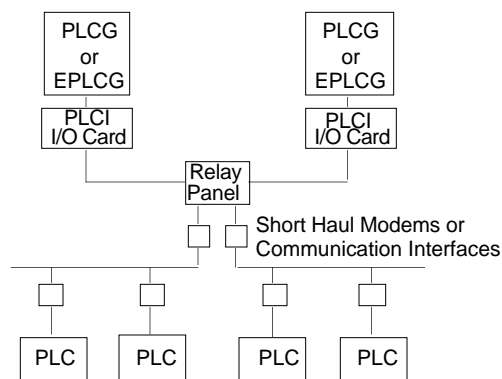

PLCG/EPLCG Configuration for Type 3 Installations

53305

Type 4 is used with nonredundant communications, Allen-Bradley protocol and Communications Interfaces. This configuration (Type 4) is the only one for which the pinning header on the relay panel is plugged into the socket marked “REDUNDANT A-B.”

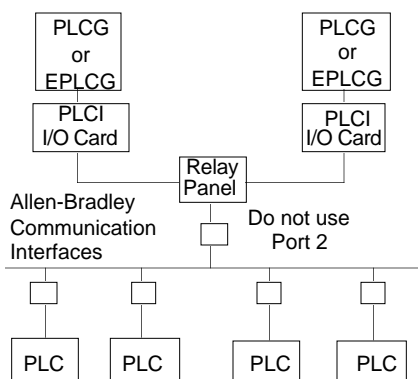

PLCG/EPLCG Configuration for Type 4 Installations

53306

Type 5 is used with redundant communications, the relay panel, Honeywell or Modbus protocols and Short Haul Modems.

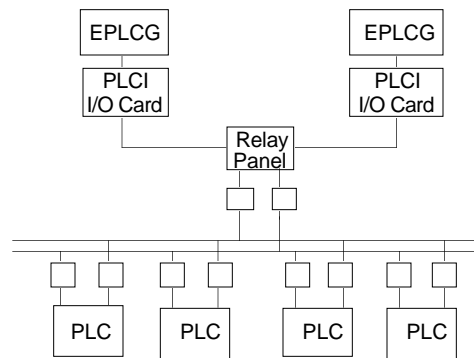

EPLCG Configuration for Type 5 Installations

53307

**2.4.3 MP-REPLC1 REDUNDANT GATEWAYS WITH A-B REDUNDANT COMMUNICATIONS**

Type 6 can only be configured with 2 EPLCGs, EPLCI I/Os, Interlink cable, Allen-Bradley Communications Interfaces, and uses the Redundant Communications option for Allen-Bradley protocol. The Interboard link is asynchronous RS-422, at 38.4 Kbaud, and dedicated to primary EPLCG-to-secondary EPLCG (redundant partner) communications.

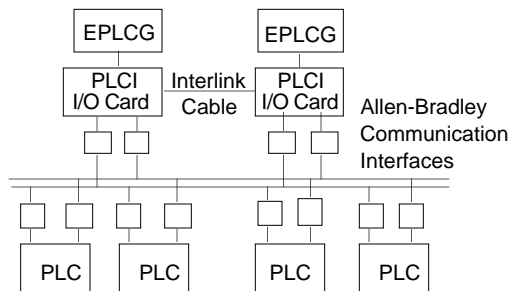

EPLCG Configuration for Type 6 Installations

53308

## 2.4.4 Redundant Gateway Configurations

Figure 2-2 shows two EPLCG dual node modules connected in a redundant configuration. Although two nodes can reside in one dual node module, a possible back panel failure precludes using a redundant pair of EPLCGs in one dual node module. This configuration also supports up to a total of 16 PLCs. See subsection 2.6.3 for examples of redundant port cabling configurations.

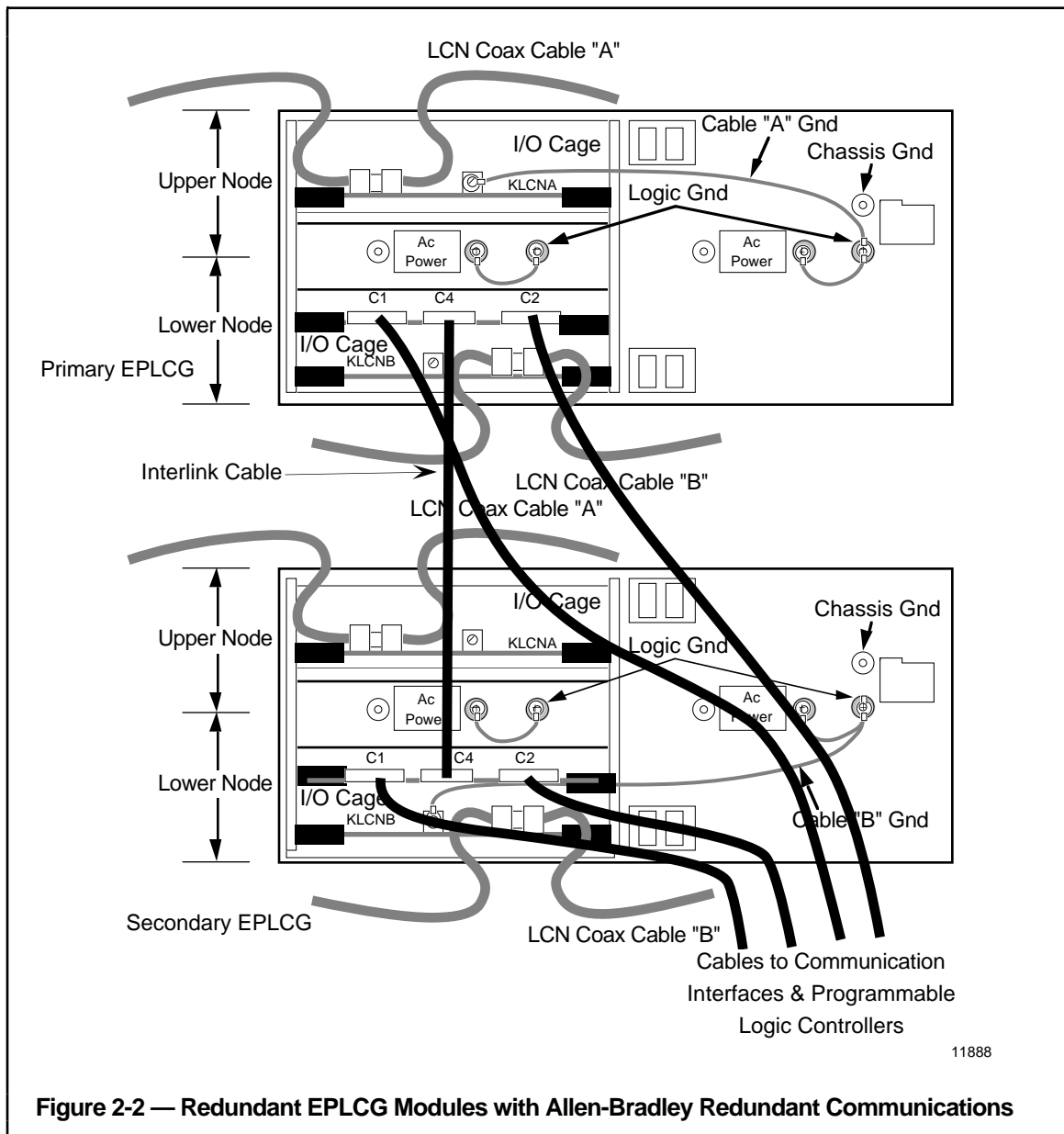

If you use Modbus protocol in a redundant EPLCG configuration, both ports (Port 1 and Port 2) must be configured for Modbus compatible equipment. The configuration is again capable of serving up to 16 PLCs on both ports. The pinning header on the EPLCG Relay Card must be plugged into the **OTHERS** socket. See subsection 3.2.4 and Figure 3-3 for a more detailed illustration of the pinning sockets and header.

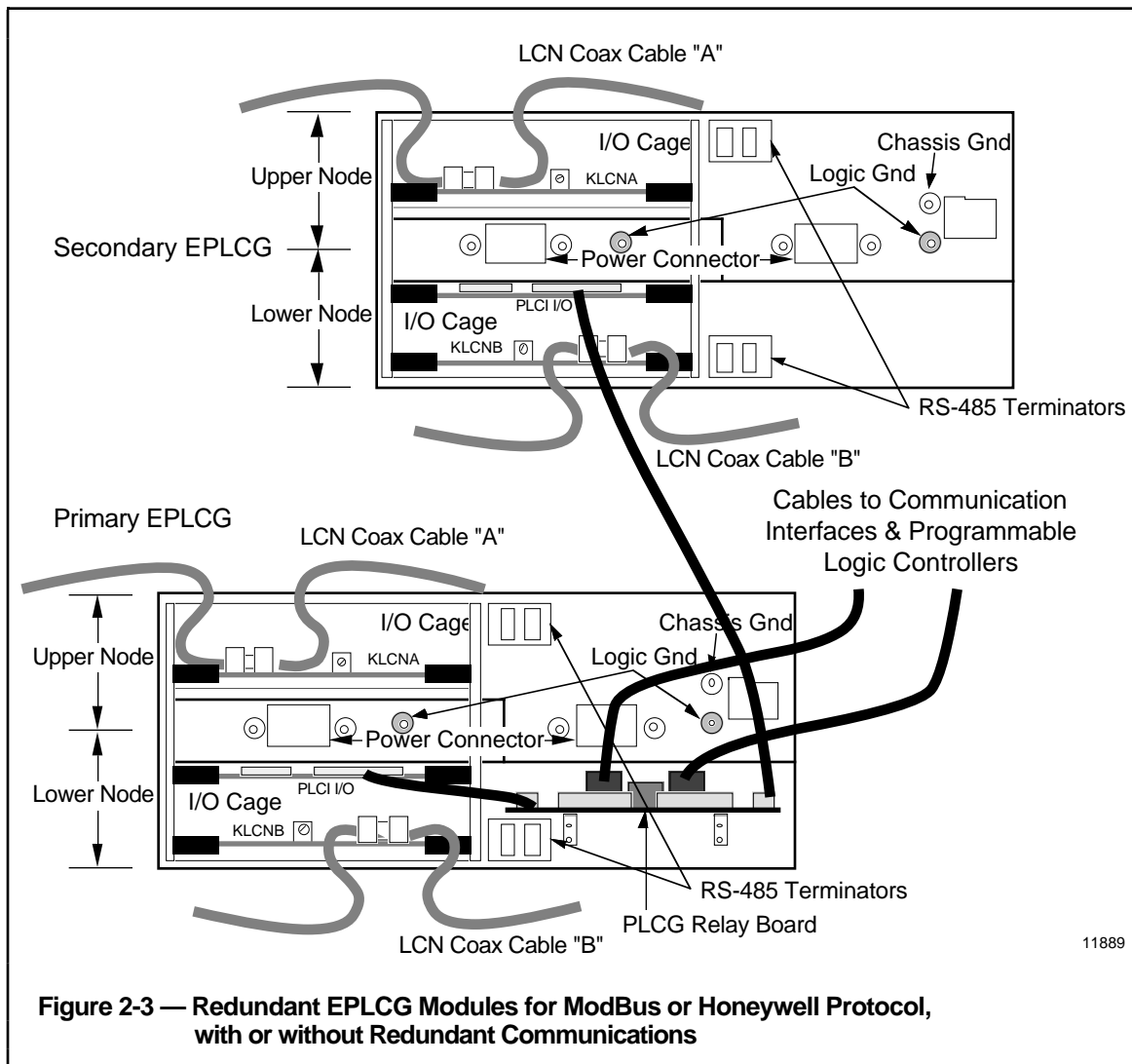

If you use Allen-Bradley protocol in a redundant EPLCG configuration, with PLCI I/O and the relay panel (without the Redundant Communications pinning), only Port 1 can be used. You must plug the pinning header on the Relay Card into the **REDUNDANT A-B** socket and be sure no cable is connected to Port 2. This configuration is capable of serving up to 16 PLCs on Port 1 through an Allen-Bradley communications controller. See subsection 3.2.4 and Figure 3-3 for a more detailed illustration of the pinning sockets and header.

If you use the redundant communications feature with PLCI I/O and the relay panel, do **not** use the socket marked **REDUNDANT A-B**. You must plug the pinning header on the EPLCG Relay Card into the **OTHERS** socket.

**NOTE**

The EPLCG can be configured for “Redundant Communications,” which will provide PLC Network Cable redundancy, with or without gateway redundancy.

**2.5 Limitations**

There are certain limitations and several options which must be considered in planning your installation.

**2.5.1 Physical Limitations**

In a redundant EPLCG application, the primary and secondary EPLCG modules generally mount in the same rack, but cannot be located in the same dual node module. They are normally installed close to each other because of interlink or relay panel cable length restrictions.

If your system uses an interlink cable, its length is fixed at 3 meters. Alternate cable lengths are not available.

If your system uses a relay panel, alternate cable lengths are available. However, if a longer relay panel cable is used, the amount added to the relay panel cable must be subtracted from each of the Port 1 and Port 2 cables. Obviously, the length of a substitute relay panel cable must be less than 15 meters (50 feet).

**2.5.2 Single vs. Multidrop Cabling**

There must be only a single cable from a port to the PLC, modem, or communications controller that port is to service.

If you want to use a Modbus protocol multidrop arrangement, you must place a local modem at the EPLCG with remote modems connected to each of the PLCs in the network.

Allen-Bradley (A-B) protocol multidrop arrangements always connect through an Allen-Bradley communications controller (a CIM, for Communications Interface Module). Since this communications controller supplies the multidrop connections, only a single cable is needed from the EPLCG port to the A-B controller.

**2.5.3 Cable Lengths**

The cables from the EPLCG ports cannot be longer than 15 cable-meters (50 cable-feet). If the distance to a PLC or communications controller exceeds this limit, you must use short-haul modems. See subsection 2.6 for modem considerations. Subsection 3.2.6 shows how to wire the RS-232 cable supplied by Honeywell so that it will interface a modem.

## 2.5.4 Direct Connection

If you are connecting a single PLC (or an A-B communications controller) to one of the ports and the cable-length from the EPLCG to the PLC is less than 15 cable-meters, you can use an RS-232 direct-connection (no modems).

In this arrangement, the RS-232 cable supplied by Honeywell must be specifically wired to a connector which mates your PLC. Subsections 3.2.7 and 3.2.8 show cable wiring schemes for several types of PLCs and interface devices.

## 2.6 EPLCG TO PLC CONNECTIONS

### 2.6.1 Modem Usage and Selection

Either direct-connection or short-haul modems (sometimes called line-drivers) can be used with the EPLCG. As mentioned earlier, direct-connection is limited to a maximum of 15 cable-meters.

A short-haul modem presents an RS-232 hardware interface to the EPLCG or PLC similar to that presented by conventional telephone modems. The short-haul modem, however, uses separate lines (not telephone lines) and may take some liberties with interface protocol that would not be acceptable in conventional telephone modem communications.

Conventional telephone modems are not used with the EPLCG because they severely limit bandwidth, and their necessary low speeds (baud rate) might degrade performance. Where the text that follows reads “modem,” substitute “short-haul modem” because of these limitations.

Use short-haul modems over moderate distances (a maximum range of 2 to 4 kilometers). Honeywell has given limited exposure to a couple of these modems and have found they performed adequately with the EPLCG—see Table 2-1 for their specifications.

**Table 2-1 — Short-Haul Modem Examples**

MANUFACTURER	MODEL NO.	DESCRIPTION
Black Box Co. Box 12800 Pittsburgh, PA 15241 (412) 746-5500	LD485A	64 Drops* maximum, 4-wire 26 AWG Twisted Pair Estimated maximum distance versus speed: 2.0 km (1.2 Miles) @ 19.2 k baud 2.7 km (1.7 Miles) @ 9600 baud 3.7 km (2.3 Miles) @ 4800 baud
AEG-Modicon, Inc. (see Local Representative)	J478	32 Drops* maximum, 4-wire 22 AWG Shielded twisted pair (Modicon recommends Belden #8777 or equivalent) Maximum distance: 4.5 km (2.8 Miles) Maximum speed: 19.2 k baud

\* Honeywell supports a maximum of 16 drops on both ports of the EPLCG.

There are also some fiber-optic “modems” on the market that may be used where the maximum distances above are insufficient. Please check with your Honeywell representative before utilizing this type of equipment in your application.

## 2.6.2 Nonredundant EPLCG Port Connections

Figure 2-3 (A) and (B) illustrate examples of directly connecting PLCs to a nonredundant EPLCG. A maximum of only two PLCs may be connected in this manner.

Notice the cables can be no longer than 15 meters. Also note the cables must be wired so that both the EPLCG and the PLCs “think” they are connected to a modem. Details of this cross-wiring will be covered in subsections 3.2.7 and 3.2.8.

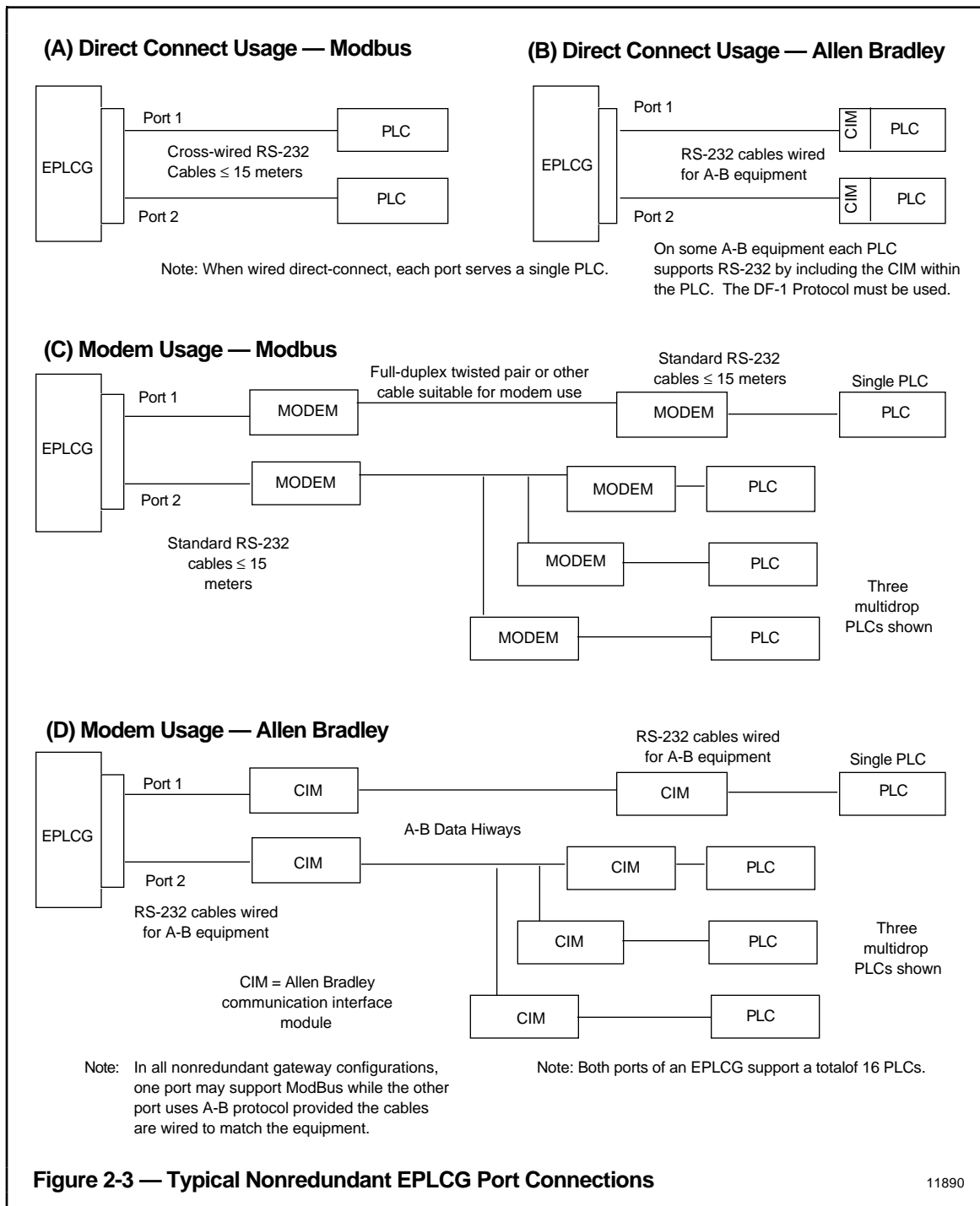

Figure 2-3 — Typical Nonredundant EPLCG Port Connections

11890

Allen-Bradley includes their CIM (Communications Interface Module) inside some PLC models, allowing the “direct” connection shown in (B). See Section 3 for detailed wiring of this cable.

Figure 2-3 (C) and (D) illustrate examples of modem usage from a nonredundant EPLCG.

The modems used in illustration (C) are the short-haul modems previously discussed. The single PLC connected by two modems to Port 1 illustrate a maximum-length configuration which will service a PLC at the greatest distance from the EPLCG.

The multidrop PLCs connected to Port 2 in illustration (C) show a typical “network” of PLCs using the Modbus protocol. These drops are connected half-duplex with the “local” modem connected to the EPLCG and “remote” modems connected to the PLCs. The local is a “master” which commands each remote to respond at a specific time. Additional loading caused by several modems on the network may reduce the overall length of the network twisted pair cable; consult the manuals for your modem for particulars. Specific details for wiring and pinning these modems are contained in subsection 3.2.6.

Illustration (D) shows Allen-Bradley equipment connected in similar arrangements to illustration (C). Allen-Bradley protocol is full-duplex; that is, any PLC or the EPLCG may “talk” at any time. Allen-Bradley requires use of their own CIMs which interface their own Data Hiway. Refer to subsection 3.2.8 and your Allen-Bradley manuals for specifics.

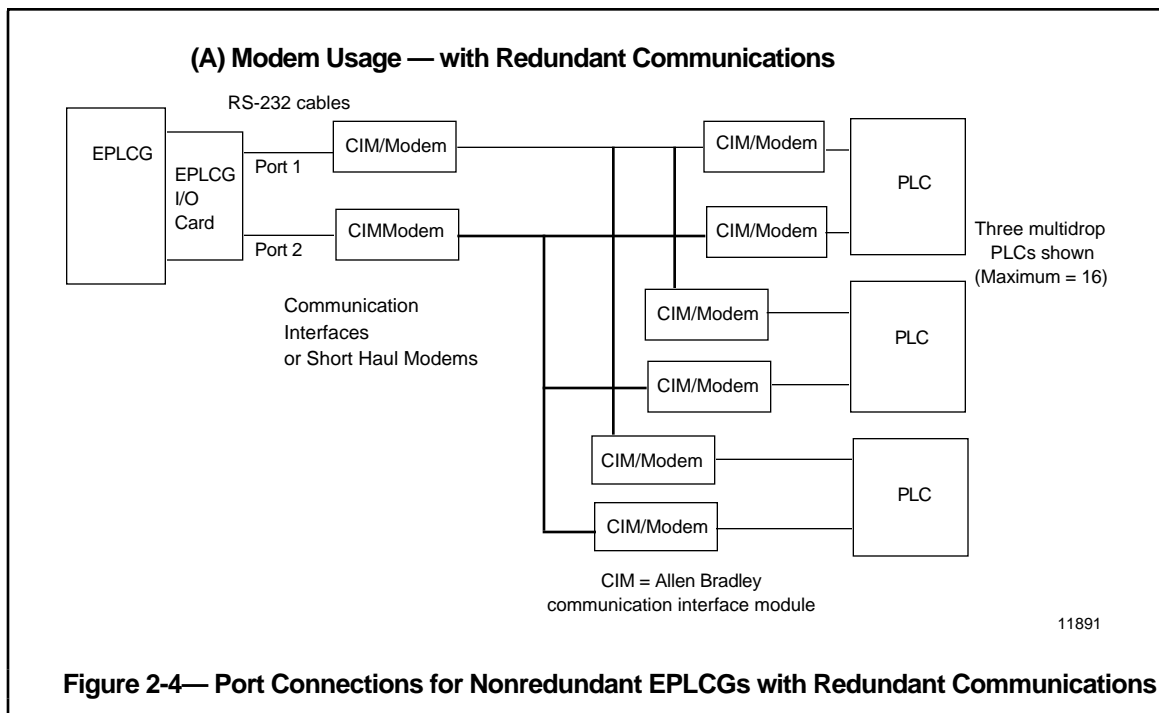

## 2.6.3 Redundant EPLCG Port Connections

Figure 2-5 (A) and (B) illustrate examples of direct-connection to PLCs from a redundant EPLCG. Note there can be only two PLCs connected in this manner if you are using Modbus protocol or only one PLC if you are using the Allen-Bradley protocol without the redundant communications feature.

Port 2 cannot be used with Allen-Bradley protocol, without the redundant communications feature, because the protocol is full-duplex and messages can be sent and received simultaneously. The redundant EPLCG firmware uses that port to “listen” to outgoing messages while Port 1 is receiving messages. Modbus protocol is half-duplex and messages are not sent and received simultaneously.

Notice Figure 2-5 (C) and (D) are very similar to those illustrations in Figure 2-3. Allen-Bradley full-duplex operation prevents Port 2 from being used, without the redundant communications feature, but there is little loss of capability since up to 16 PLCs can be connected to the same network.

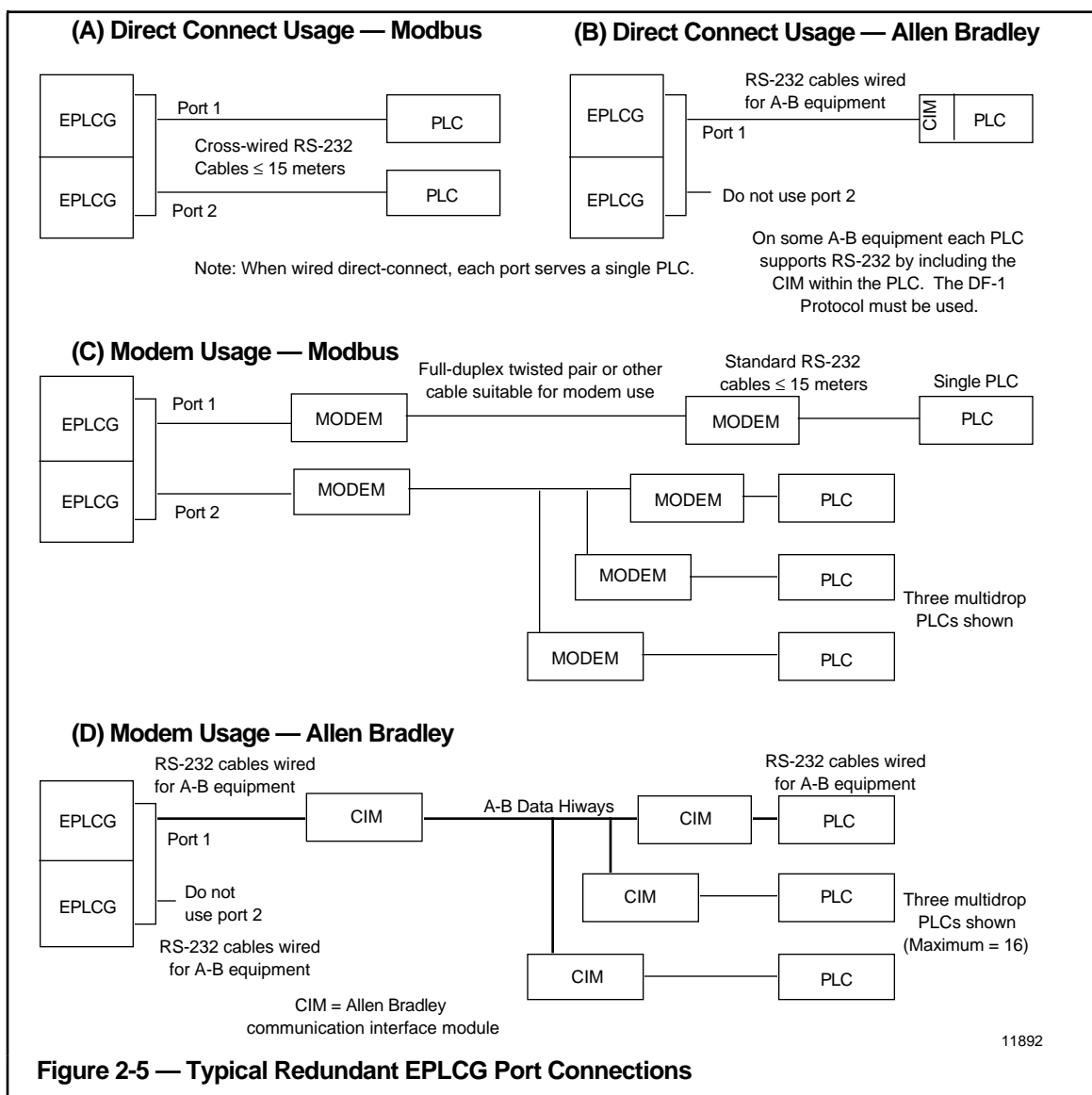

### 2.6.4 Port Connections for Redundant EPLCGs with Redundant Communications

Figure 2-6 illustrates typical port connections for redundant EPLCGs for use with the redundant communications feature. In (A), redundant communications are specifically for use with Allen-Bradley PLCs, connected by Allen-Bradley Communication Interface Modules, and provide network cable redundancy.

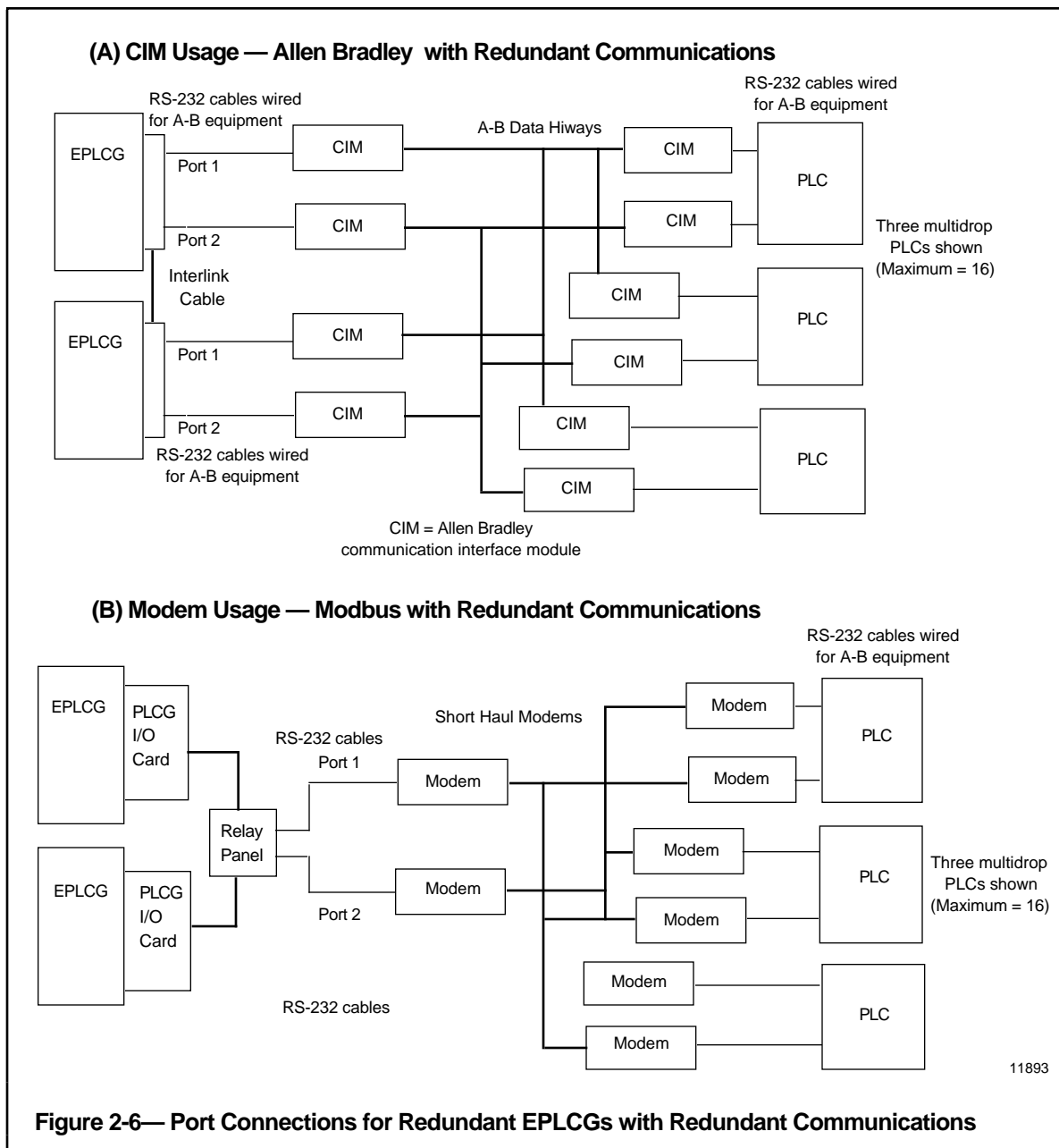

Figure 2-6 (B) illustrates use of the PLCG I/O card and relay panel with Honeywell or Modbus protocol and redundant communications.

## INSTALLATION Section 3

*This section provides information for unpacking and assembling the EPLCG.*

### 3.1 UNPACKING

When the equipment arrives at the system site, open each shipping box, remove the protective wrapping and carefully inspect each piece for any physical damage. If damaged, immediately notify the carrier and your Honeywell sales representative as to the extent and type of damage. Also check each piece of equipment against the invoice list for any missing items.

### 3.2 ASSEMBLY AND CABLING

Refer to Figure 2-1 for an illustration of a nonredundant EPLCG installation.

Refer to Figure 2-2 for an illustration of a redundant EPLCG installation. Note the EPLCG relay panel is only mounted on the primary EPLCG.

#### NOTE

Some assembly and cabling of this equipment may have been done at the factory. If so, please check your equipment and verify its installation is similar to that described.

#### 3.2.1 Module Installation

If you are installing a redundant EPLCG pair, you have two EPLCG modules. Install the primary EPLCG module first.

1. Remove the primary EPLCG module (with relay panel, if included) from its shipping carton.
2. Securely fasten the EPLCG module to its rack-mount with the hardware provided.
3. Connect ground straps or leads from the base of the cabinet (or a nearby module) to the appropriate chassis-ground and logic-ground connections on the rear of the EPLCG module. Refer to the *LCN System Installation* manual in the *LCN Installation* binder for further grounding information.
4. Insure the power switch on the front of the EPLCG module is off. Install the module power cord supplied. Refer to *LCN System Installation* manual in the *LCN Installation* binder for power wiring information.

If this is a redundant installation, repeat steps 1 through 4 on the secondary EPLCG module.

### 3.2.2 LCN Node Pinning

By convention, the node address for a nonredundant EPLCG is even. The node addresses for a redundant pair is even for the primary EPLCG and numerically one higher (odd) for the secondary EPLCG.

If you are installing a nonredundant EPLCG, perform the following steps on the EPLCG module. If this is a redundant EPLCG installation, perform these steps twice, using a node address on the secondary EPLCG one higher from that of the primary EPLCG.

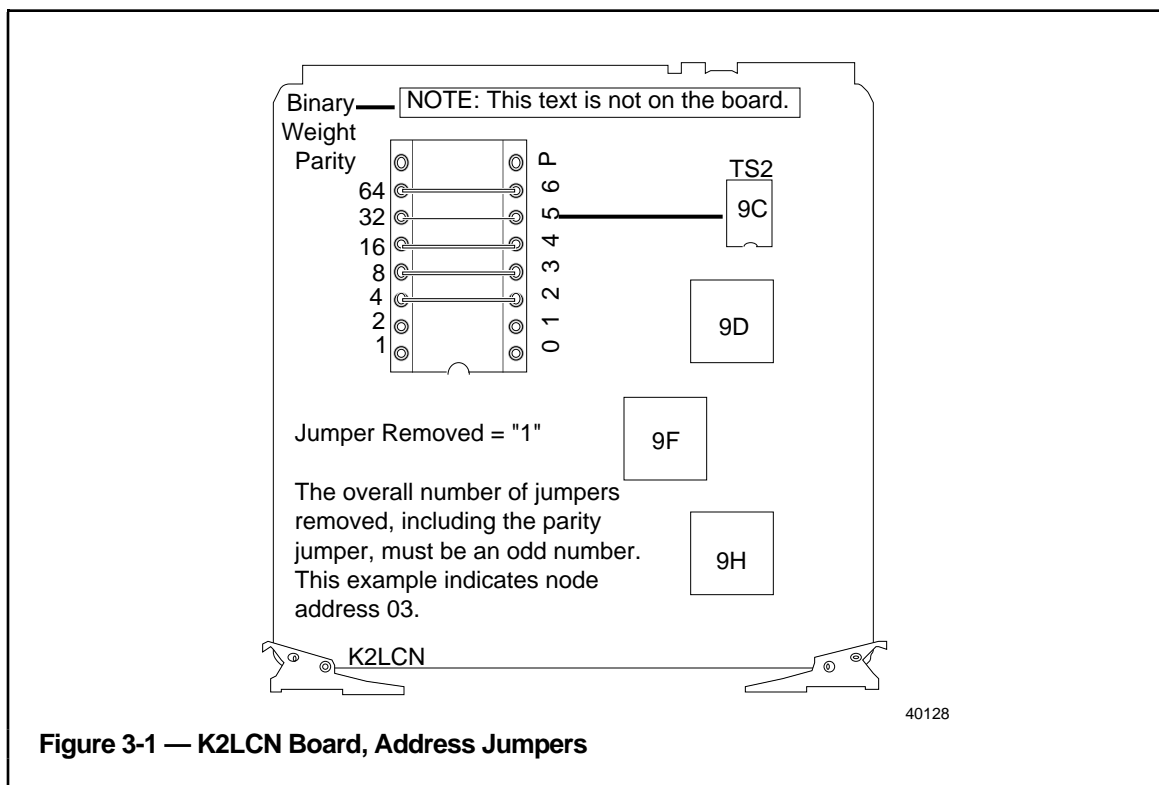

1. Remove the K2LCN board from front slot 1 in the EPLCG module. Refer to Figure 3-1 or Figure 3-2 for instructions and the location of the pinning header on the board. Pin the LCN node address as shown. Be sure to adjust the parity jumper as required.
2. Reinstall the K2LCN board.

### 3.2.3 EPLCI Pinning

Refer to Figure 3-2 to locate the pinning headers and jumpers in the following steps. If you are installing a redundant EPLCG pair, both EPLCI boards must be pinned the same way.

#### 3.2.3.1 Ram Clear (J1)

Locate J1 and insure that a jumper is installed.

#### 3.2.3.2 Board Revision (TS1)

Do not alter TS1, the Board Revision header.

#### 3.2.3.3 Baud Rate and Parity (TS2)

The baud rate of the two serial interfaces serving Ports 1 and 2 are set-up with the jumpers on TS2 (near right-center of board in Figure 3-2). See Table 3-1 (or the table on the EPLCI board) for the pinning information. Be sure the baud rate for a given port matches the PLC(s) it is communicating with. The baud rates of the ports may be set at different speeds. Notice Port 1 uses the higher-numbered pins.

The transmit and receive data parity for Ports 1 and 2 are set by jumpers 5 and 1, respectively. To send and receive odd parity on a port, its respective jumper must be shorted. Conversely, even parity is obtained by the jumper being open. Make sure the parity of a port agrees with the parity sent and expected by the PLC(s) to which it is connected.

**Table 3-1 — Baud Rate Pinning on EPLCI Board**

BAUD RATE	PORT 2			PORT 1		
	PIN 2	PIN 3	PIN 4	PIN 6	PIN 7	PIN 8
50	OPEN	OPEN	SHORT	OPEN	OPEN	SHORT
150	OPEN	SHORT	OPEN	OPEN	SHORT	OPEN
300	OPEN	SHORT	SHORT	OPEN	SHORT	SHORT
1200	SHORT	OPEN	OPEN	SHORT	OPEN	OPEN
2400	SHORT	OPEN	SHORT	SHORT	OPEN	SHORT
4800	SHORT	SHORT	OPEN	SHORT	SHORT	OPEN
9600*	SHORT	SHORT	SHORT	SHORT	SHORT	SHORT
19.2KB	OPEN	OPEN	OPEN	OPEN	OPEN	OPEN

\*Honeywell factory setting is 9600 baud

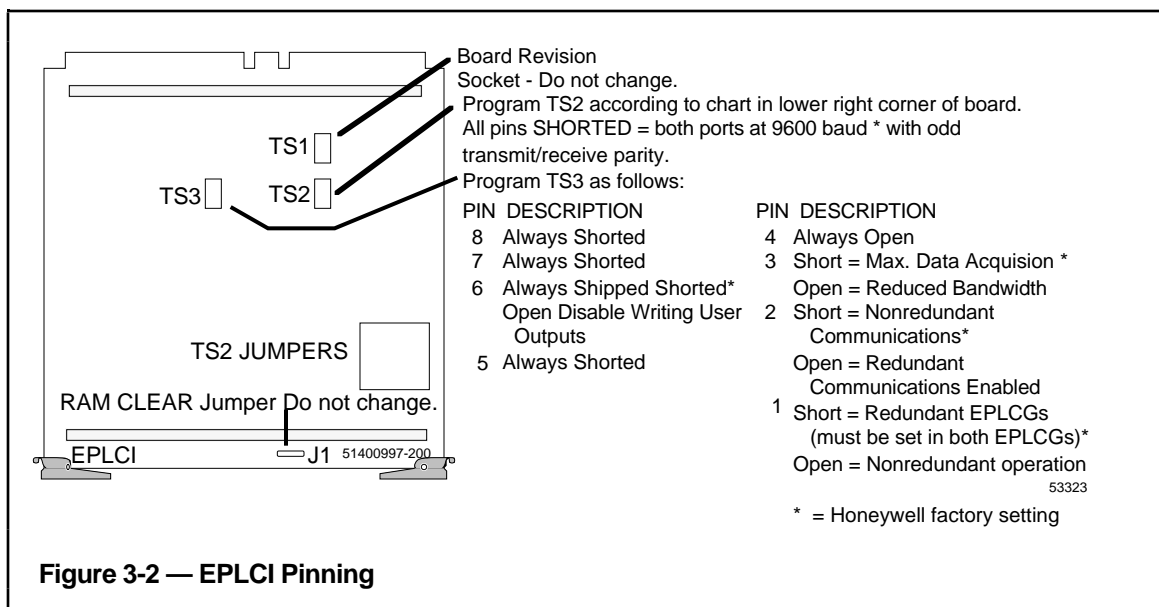

### 3.2.3.4 Program Options (TS3)

- Pin 1 If you are installing redundant EPLCGs, leave pin 1 shorted (it must be shorted on the EPLCI board in both EPLCGs). If you are installing a nonredundant EPLCG, open pin 1.
- Pin 2 This pin controls the Redundant Communications feature. With pin 2 shorted, Redundant Communications are not enabled. Ports 1 and 2 are treated as two independent paths each with a set of unique PLCs. If you want the Redundant Communications feature enabled, open pin 2. Ports 1 and 2 will then be treated as redundant communications paths to a single set of PLCs.

- Pin 3 If you want the EPLCG to acquire data at the maximum rate, leave pin 3 shorted. If you want the acquisition rate reduced, open this pin. Note that with this pin shorted, data is double-buffered; when the pin is opened, one data buffer is disabled.
- Pin 4 Always leave this pin open.
- Pin 6 Always shipped shorted. If open, the EPLCG becomes a “Read Only” device (will not write user outputs).
- Pins 5, 7 & 8—Always leave these pins shorted.

### 3.2.4 EC Installation of EPLCI I/O Board

The EPLCI I/O board provides the interfaces to a network of Programmable Logic Controllers. The cabling connections are now bulkhead-mounted into the card faceplate which provides a contiguous shield from module to cable. The faceplate is shown in Figure 3-3. The cables have all been redesigned to braid over foil shields and metalized plastic shield back-shells. This extends the shield of the sheet metal module out along the cable, thereby minimizing emissions and susceptibility.

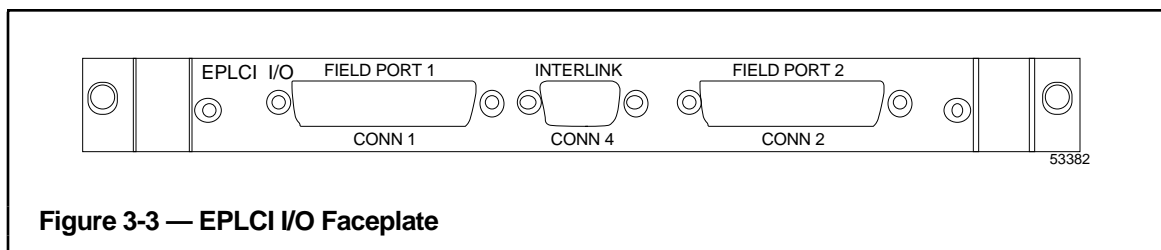

Figure 3-3 — EPLCI I/O Faceplate

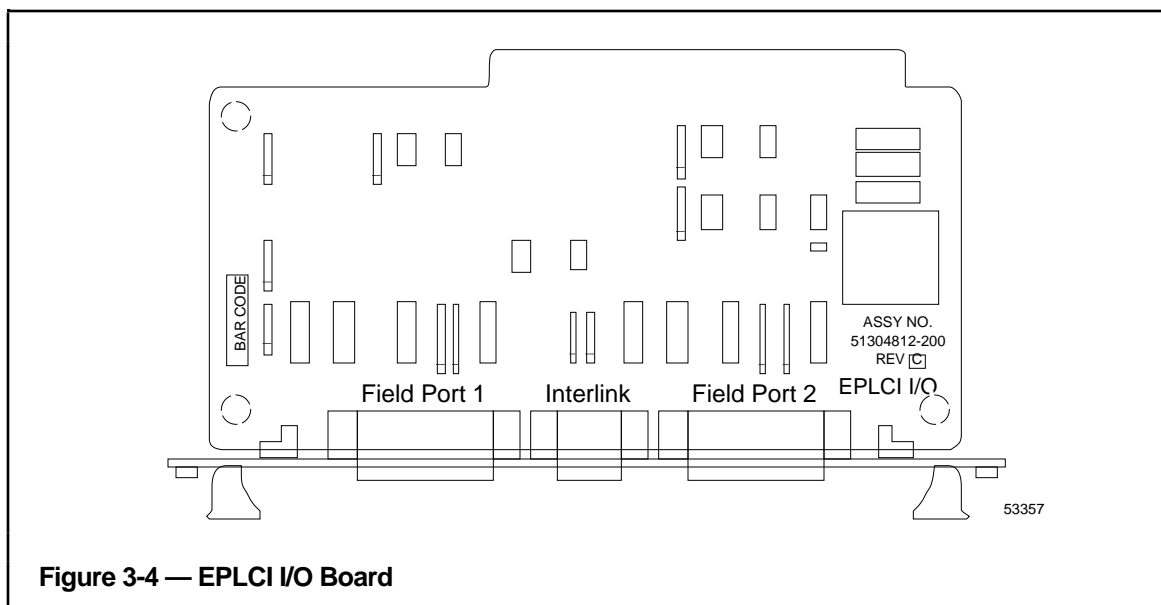

Figure 3-4 — EPLCI I/O Board

### 3.2.5 EPLCG Relay Panel Pinning

Refer to Figure 3-2. If you are installing a nonredundant EPLCG or if you are assembling a redundant Modbus installation, check that the header on the relay panel is in the **OTHERS** socket.

If you are assembling a redundant EPLCG pair with an Allen-Bradley installation and using a PLCI I/O board with the relay panel, be sure the relay panel header is in the **REDUNDANT A-B** socket.

#### 3.2.5.1 EPLCG Relay Panel for EC

The relay board is mounted on a bracket on the outside of the module; therefore, it is not within the shield of the module sheet metal. To make it CE compliant, several changes were made to minimize EMC. These changes include adding a chassis ground layer to both outside (exposed) layers of the board. The connector shield was changed by using a 360 degree shield connector, and changing the cables to braid over foil shields with 360 degree shielded back-shells.

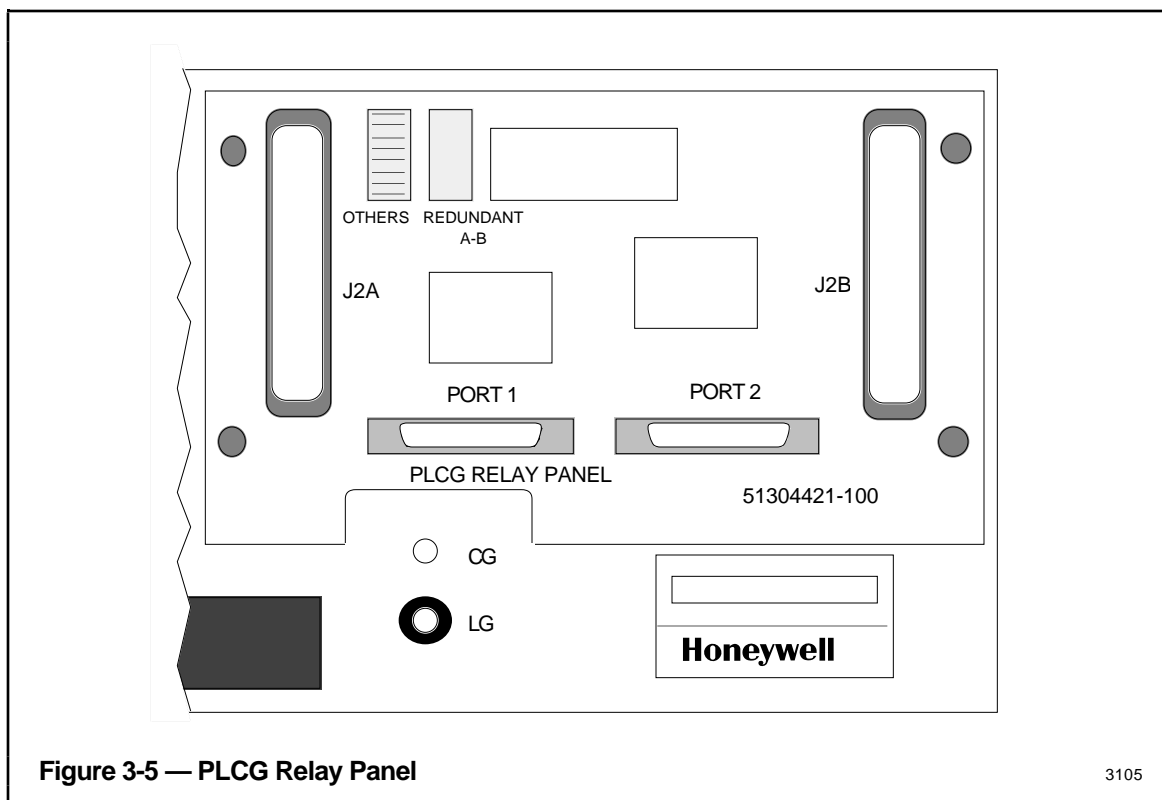

Figure 3-5 — PLCG Relay Panel

3105

### 3.2.6 EPLCG Cabling

1. If you are using an EPLCI and EPLCI I/O (without the relay panel), no intermediate cable is necessary. Connect from Port 1 and Port 2 (C1 and C2 on the EPLCI I/O board) to the Short Haul Modem(s) or Communications Interface Module(s).
2. If you are using a PLCI and PLCI I/O with the relay panel, connect a 1 meter (3 ft.) cable (30731611-001) from J2A on the relay panel to J2 on the PLCI I/O board at the rear of the module. If necessary, refer to Figure 2-2.
3. If this is a redundant Gateway installation using the relay panel, connect a 2 meter (6 ft.) cable (30731611-002) from J2B on the relay panel to J2 on the PLCI I/O board in the secondary module. If necessary, refer to Figure 3-2.
4. If this is a redundant Gateway installation not using the relay panel, connect an Interlink cable (51196074-100) from C4 on the EPLCI I/O board in the primary module to C4 on the EPLCI I/O board in the secondary module. If necessary, refer to Figure 2-2.
5. Be sure the two latches which secure each cable-end to its connector are fastened on all of the cables.

### 3.2.7 Port Cabling and Pinning for Modems Using Modbus Protocol

#### NOTE

Two 51304514-100 field port cables, each without a plug on one end, have been shipped with your EPLCG. You must purchase and install the proper plugs to mate your brand and model of equipment. This section will aid you in selecting and wiring those plugs.

#### 3.2.7.1 Modem Cable

For connection to a Modicon J478 modem or other short-haul modem serving a Modbus port as illustrated in Figure 2-3 (C) or 2-5 (C), install a connector on the free-end of cable 51304514-100 using Figure 3-6 as a guide. Use a standard 25-pin male, D-Sub connector.

#### 3.2.7.2 Modem Wiring

Use the instruction manual provided with your modems to install modem wiring between all of the modems. Be sure the wiring meets the following criteria.

- The multidrop modem “telephone lines” must be 4-wire, full-duplex with the line-driver of the local modem (EPLCG end) in parallel with the line-receivers of all remote modems (PLC ends). Likewise, the line-drivers of all remote modems are in parallel with the line-receiver of the local modem.
- A single pair of modems (point-to-point) must also be 4-wire, full-duplex with the line-driver of each modem in parallel with the line-receiver of the other modem.

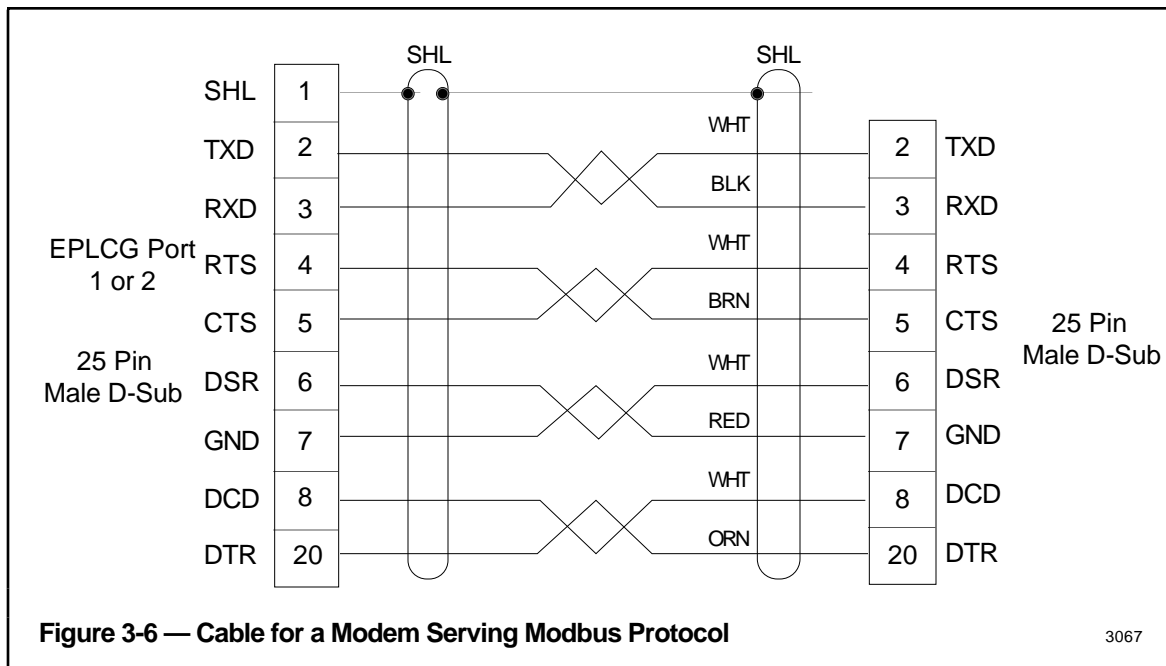

### 3.2.7.3 Modem Pinning

Use the instruction manual provided with your modems to properly pin your modems. Be sure they meet the following criteria.

- The local (EPLCG end) modem must be pinned to hold its transmitter enabled at all times, normally by putting RTS/CTS in the ON position.

The local modem must also be pinned to hold RXD in the marking state in the absence of a valid carrier.

- Each remote (PLC end) multidrop modem must be pinned to enable its transmitter only when the PLC raises RTS.

All remote modems must also be pinned for an RTS/CTS delay of approximately 5 to 15 milliseconds. This delay can be determined empirically by the user, based upon the hardware he has chosen. We have found the LD485A Black Box modems (Table 2-1) operate satisfactorily using the 5 millisecond delay. (RTS/CTS delay need not be pinned in the local modem of a multidrop network, and is also immaterial in a point-to-point arrangement.)

### 3.2.8 Port Cabling for Direct Connection to Modbus Equipment

#### NOTE

Two 51304514-100 field port cables, each without a plug on one end, have been shipped with your EPLCG. You must purchase and install the proper plugs to mate your brand and model of equipment. This section will aid you in selecting and wiring those plugs.

If wiring information is not given here for your equipment, check with Honeywell's Multivendor Interface Program. If an MVI Program Test Report is available for that equipment, cable wiring information will be given in that report.

For direct connection to Modbus protocol PLCs as illustrated in Figure 2-3 (A) or 2-5 (A), use Table 3-2 to find the model number of the equipment you are using. From the table, locate the figure which will aid you in obtaining the proper connector, then install it on the free-end of cable 51304514-100.

**Table 3-2 — Modbus Protocol Cable Wiring Locator**

PROGRAMMABLE CONTROLLER MAKE AND MODEL		FIGURE NUMBER
Honeywell	Honeywell 620 with 620-0043 CIM	Figure 3-7
Modicon	184 with J347 interface	Figure 3-7
Modicon	384 with J347 interface	Figure 3-7
Modicon	584	Figure 3-8
Modicon	884	Figure 3-7
Modicon	984	Figure 3-7
Triconex	4101 EICM	Figure 3-11 *

\*This device employs the Modbus protocol but uses a cable identical to one used for Allen-Bradley devices.

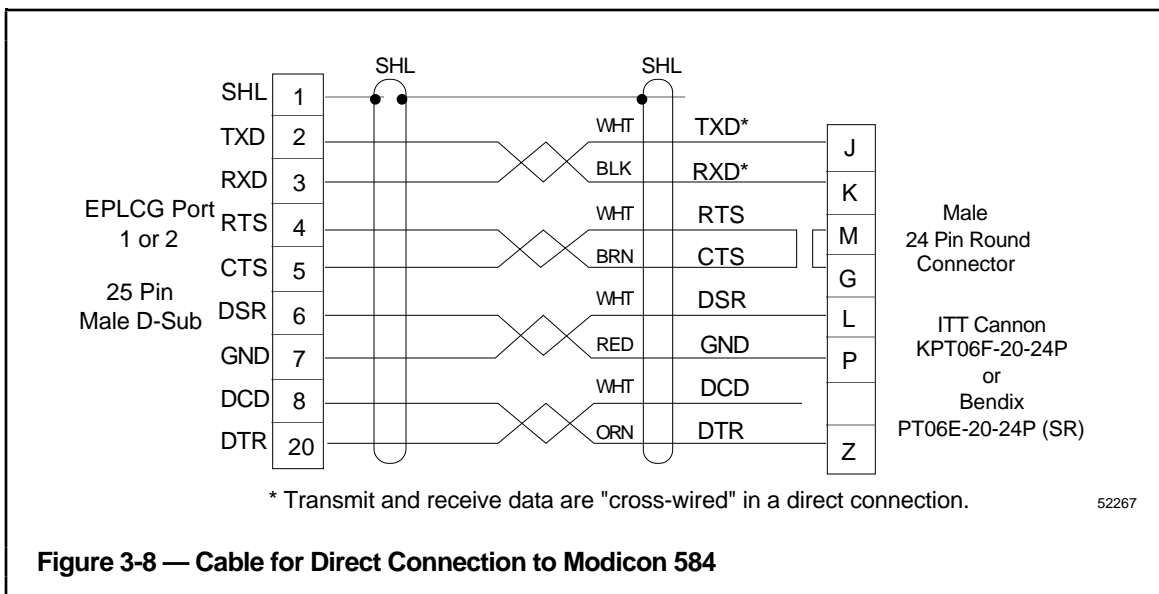
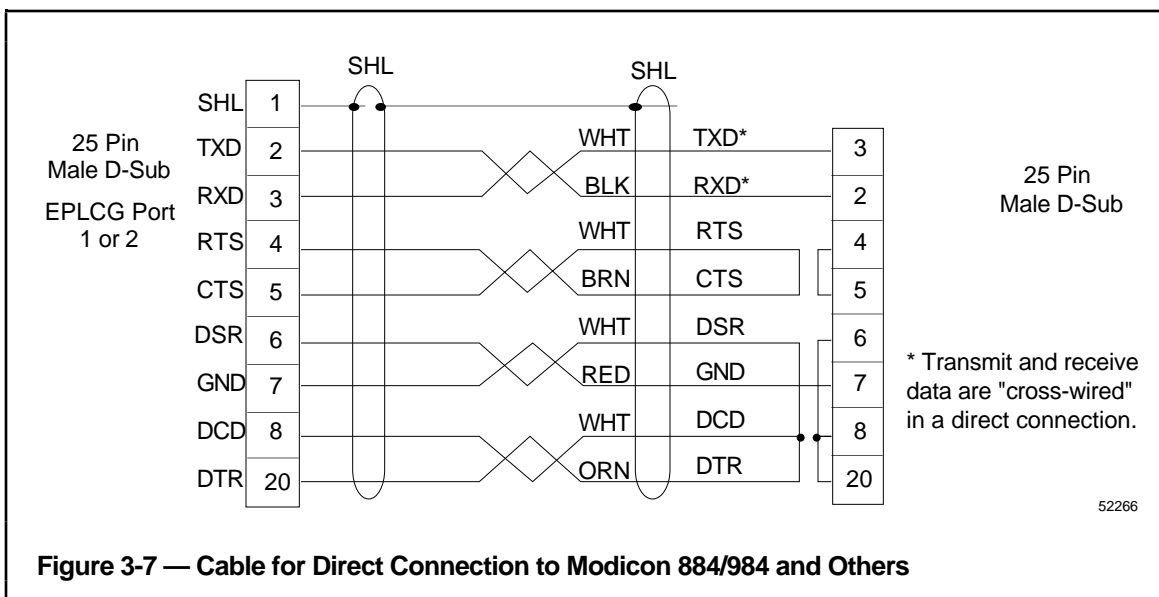

### 3.2.9 Port Cabling for Equipment Using Allen-Bradley Protocol

#### NOTE

Two 51304514-100 field port cables, each without a plug on one end, have been shipped with your EPLCG. You must purchase and install the proper plugs to mate your brand and model of equipment. This section will aid you in selecting and wiring those plugs.

If wiring information is not given here for your equipment, check with Honeywell's Multivendor Interface Program. If an MVI Program Test Report is available for that equipment, cable wiring information will be given in that report.

#### 3.2.9.1 Direct Connection to Allen-Bradley Controllers

For connection to Allen-Bradley protocol PLCs as illustrated in Figure 2-3 (B) or (D) and 2-4 (B) or (D), use Table 3-3 to find the model number of the equipment you are using. From the table, locate the figure which will aid you in obtaining the proper connector, then install it on the free-end of cable 51304514-100.

**Table 3-3 — Allen-Bradley Protocol Cable Wiring Locator**

PROGRAMMABLE CONTROLLER MAKE & MODEL		FIGURE NUMBER
Allen-Bradley	1770-KF2	3-10
Allen-Bradley	1771-KE	3-9
Allen-Bradley	1771-KF	3-9
Allen-Bradley	1771-KG	3-9
Allen-Bradley	1775-KA	3-10
Allen-Bradley	1779-KFL	3-11
Allen-Bradley	1779-KFLR	3-11
Allen-Bradley	1785-KE	3-9

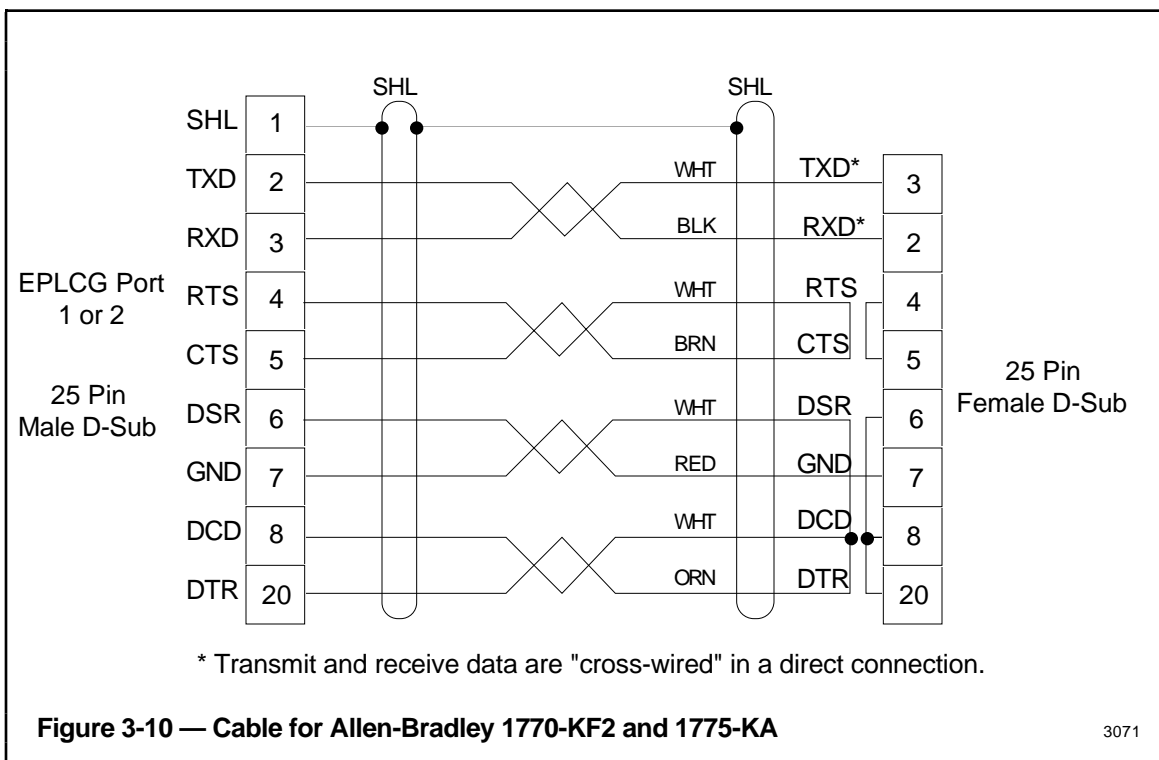
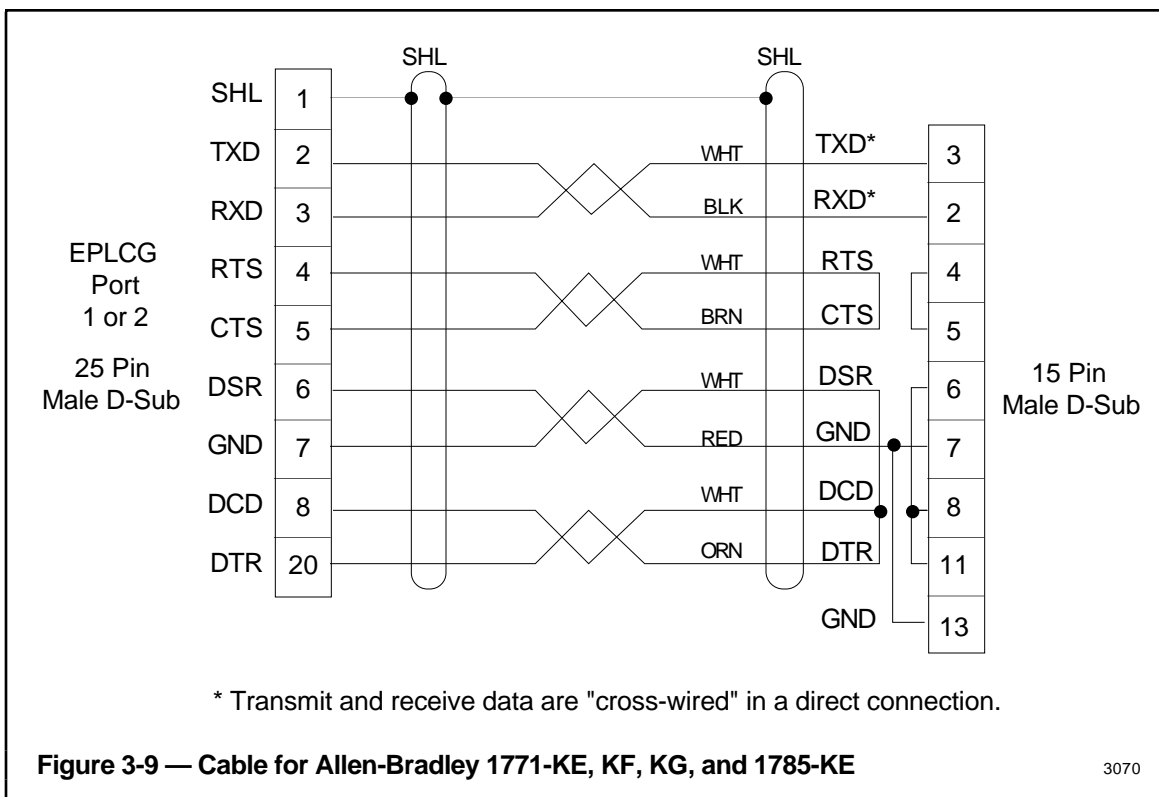

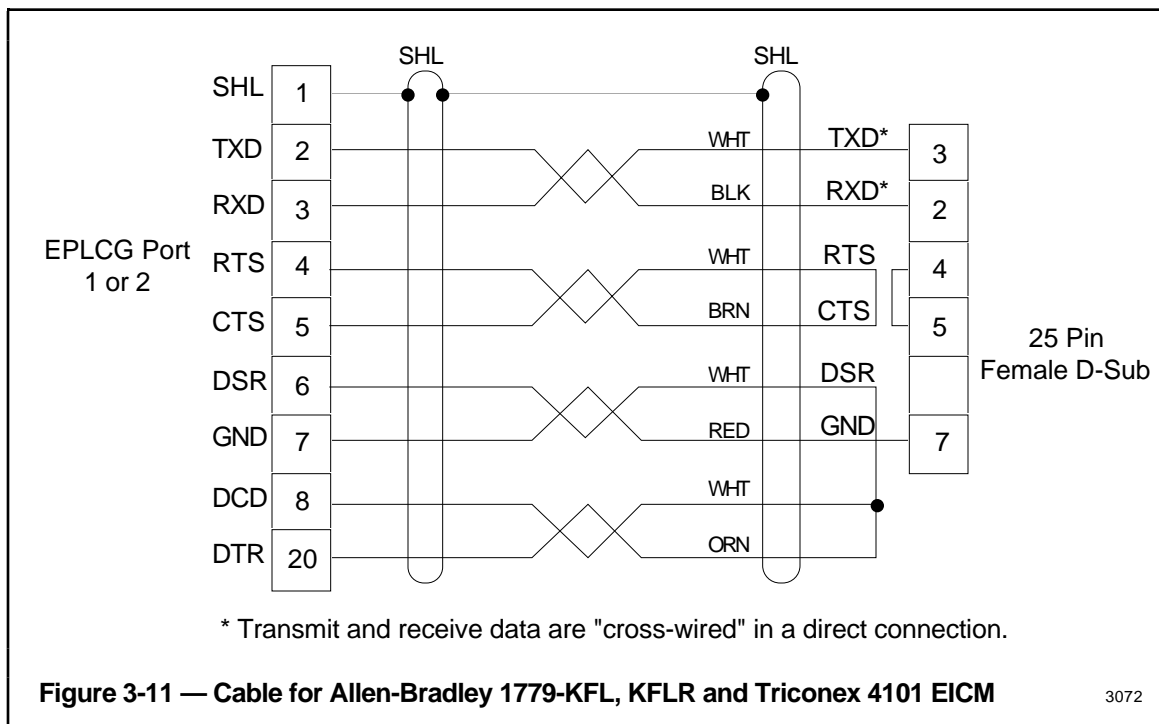

### 3.2.9.2 Allen-Bradley CIM Pinning

Methods for pinning CIMs vary between models. The parameters listed in Table 3-4 are common to all EPLCG/A-B configurations—use them as a guide.

**Table 3-4 — Allen-Bradley Communications Interface Module Settings**

PARAMETER	SETTING
BAUD RATE	Set the same as the EPLCG field port. Do not set above 9600 baud on the KF2. The KE/KF may be set to 19.2 kbaud (see A-B manual).
PARITY	EVEN
BCC/CRC	BCC (Block Check Character)
HANDSHAKING	OFF
DH/DH+	As required by A-B devices
RS-232/422	RS-232
DIAGNOSTICS	Execute diagnostics locally
EMBEDDED RESPONSES	ON
DUPLICATE MESSAGE DETECT	ON

### 3.3 INSTALLATION WRAP-UP

Dress all cables neatly and out of the way to protect them from accidental damage. Plug all modems and EPLCG modules into their proper receptacles.

## CHECKOUT Section 4

*This section tells you how to check the EPLCG after it has been installed, plugged in and is ready to go.*

### 4.1 POWER-ON TESTS

You do not need to have the PLC equipment installed or connected to perform the checks in this section. Do not, however, perform any of these tests until all other parts of the EPLCG have been installed according to Section 3.

#### 4.1.1 Electronics Checks

Perform these electronics checks on the EPLCG electronics module. If this is a redundant EPLCG installation, perform these checks on both EPLCG modules.

1. Remove the front cover of the EPLCG module. Before turning power on, ensure the **LO-NOM-HI** jumper or switch on the front of the power supply is in the center or **NOM** position.
2. Set the **POWER** switch to **ON** while observing the LEDs on the power supply, fan assembly, and on the individual cards in the unit.

Note that the red LEDs on the boards light for a few seconds (it takes less than 30 seconds to complete the power-up tests), then they turn off and the green LEDs turn on. If any red LEDs on the boards remain on, some portion of the power-up tests have failed—record the alphanumeric status display code and proceed to *Dual Node Module Service* manual in the *LCN Service-1* binder.

If the power-up test is successfully completed for all nodes, all green LEDs on all boards are on (there may also be some yellow LEDs on or flashing), and the alphanumeric status display indicates the node address you set in subsection 3.2.2 of this manual.

3. Check the power supply status LEDs (**POWER OK** and **ERROR**) and the **FAN ALARM** LED. Note that the **FAN ALARM** and **ERROR** LEDs are off and the **POWER OK** LED is on (it is a fault condition if both the **ERROR** and **POWER OK** LEDs are **ON**).
4. Press the momentary **RESET** switch. Note the power-up tests are initiated similar to step 2, and the results are satisfactory.
5. Replace the front cover.

## 4.2 STARTUP

The EPLCG software performs exactly like an HG (Hiway Gateway) and looks exactly like an HG to the operator. To continue further, load the EPLCG with the HG personality, use EPLCG configuration rules, and later use HG operations.

Configuration information is in the remaining publications in this binder. Loading and operating procedures are in the *Process Operations Manual* in the *Operation/Process Operations* binder.

## 4.3 COMMUNICATIONS AND PERFORMANCE STATISTICS

To assist installation and on-going performance monitoring, the EPLC Gateway provides information about EPLCG communications and certain EPLCG performance statistics. Once per second the information is transferred to the database of each (on-scan) emulated DHP making it available at the Universal Station through the System Maintenance Control Center (SMCC). To prevent interference with off-line operations, statistical information is not transferred to the database of an emulated DHP which is not enabled (on-scan). See Figure 4-1.

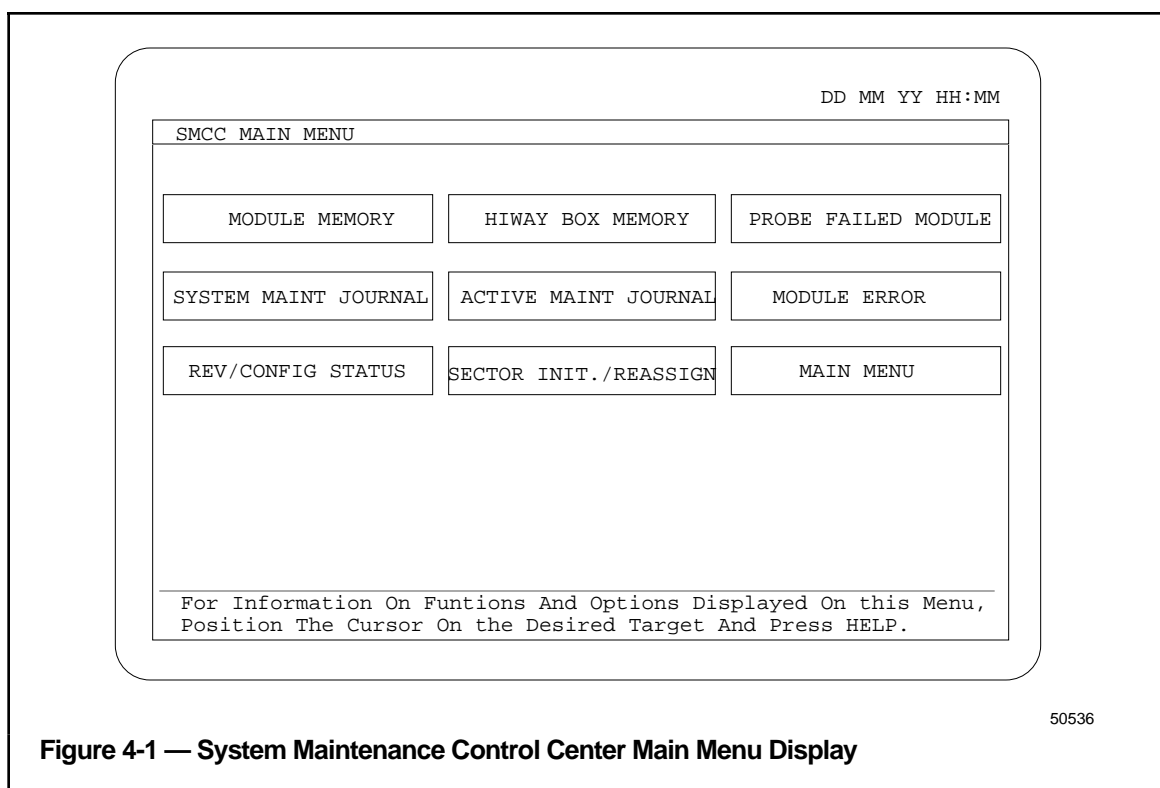

**Figure 4-1 — System Maintenance Control Center Main Menu Display**

General information on use of the SMCC is in *Maintenance Test Operations* section of the *LCN Service -1* binder.

Selection of the HIWAY BOX MEMORY target of the SMCC's Main Menu brings up a screen requiring specific data to be filled-in. See Figure 4-2.

```

04 Sep 94 08:51:16 1
HIWAY BOX MEMORY

ENTER PARAMETERS -

ENTER Hiway Number      :  (Decimal 1 To 20)
ENTER Hiway Box Address :  (Decimal 1 To 63)
ENTER First Memory Address :  (Octal)
ENTER Cyclic Update Interval :  (0 to 60 Seconds Or Off)
ENTER Change Detect      :  (ON-OFF)

For Information On Funtions And Options Displayed
On this Menu, Position The Cursor On the Desired Target
And Press HELP.
52272

```

**Figure 4-2 — Hiway Box Memory Selection Display**

Enter the correct Data Hiway number in the first "port." Add 32 (decimal) to the DHP box number and enter the result in the next "port." Enter "1700" for the First Memory Address. Also, enable "Cyclic Update Interval" and "Change Detect," if desired. Press the Enter key to display the data. See Figure 4-3.

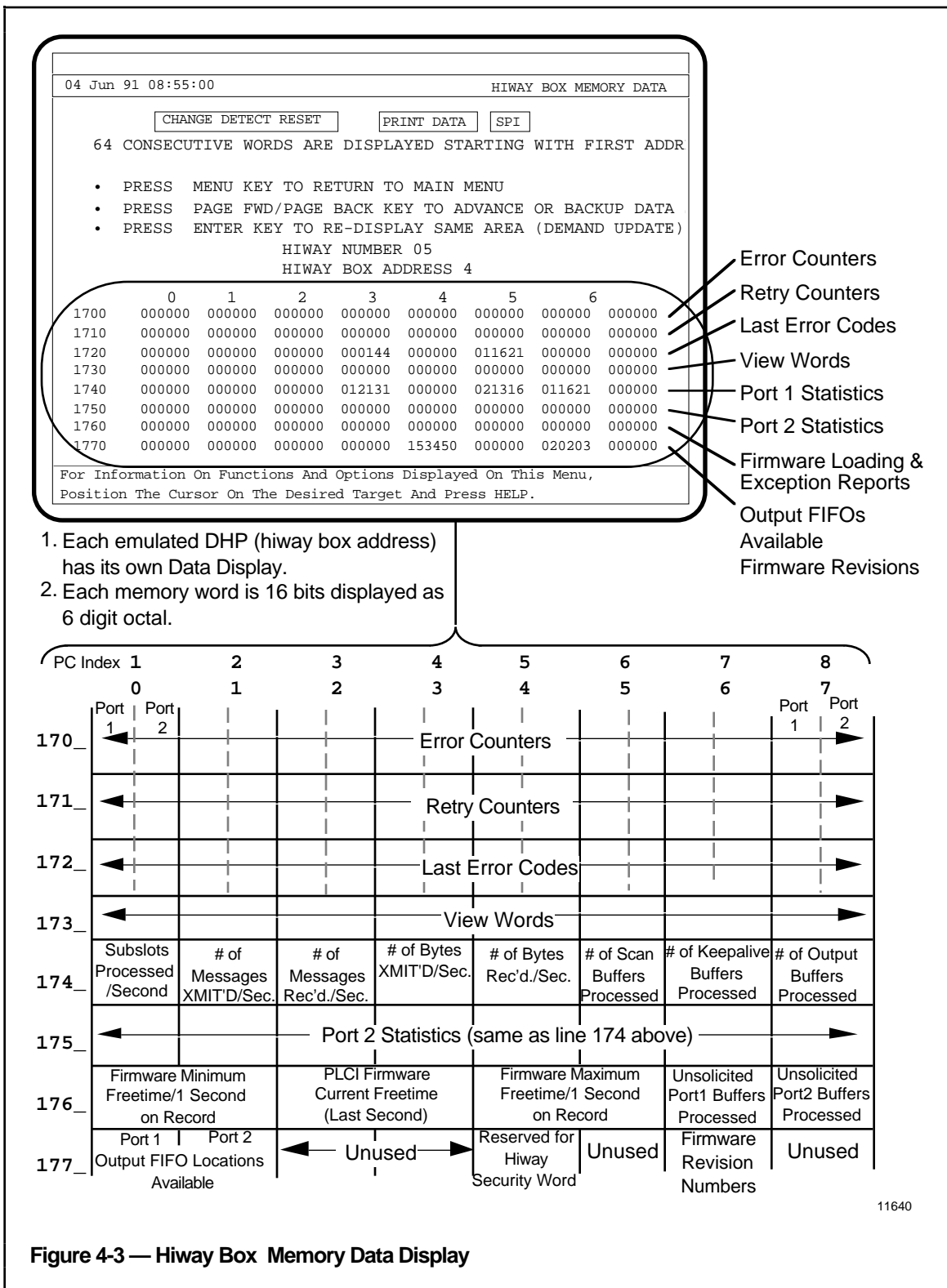

### 4.3.1 PLC Error and Retry Counters

The EPLCG maintains communications error counters (Memory addresses 1700-1707 = PLC Index 1-8, respectively) and communications retry counters (1710-1717 = PLC Index 1-8, respectively) for each configured physical PLC on each port. In each memory location, the 6 octal digits displayed represent two 8-bit counters. The upper 8 bits, 15 through 08, of each memory word are for Port 1 and the lower bits, 07 through 00, are for Port 2. When a communications error is detected between the EPLCG and the physical PLC, the error counter is incremented. If a retry is permitted, the retry counter is incremented before the retry is performed. Once-a-second the counters' results are transferred to the (enabled) DHP's database. Since the counters are kept by physical PLC, all logical PLCs (PLC index values) referencing the same physical PLC will show the same counter value. This is true even if the logical PLCs (PLC index values) are in different emulated DHPs.

The counters are allowed to rollover after reaching maximum value. Two 8-bit counters are displayed as 6 octal digits. When split into 2 counters, the 6 octal digits don't break at an octal boundary, so the Port 1 (upper byte) counter at maximum = 1774(8) and the Port 2 (lower byte) counter at maximum = 377(8); both = 255(10). The actual value is not important, only the apparent rate at which they are incrementing. Each counter is only reset when all emulated DHPs that reference its physical PLC are disabled (off-scan).

### 4.3.2 Last Error Codes

In memory addresses 1720-1727 (PLC Index 1-8, respectively) the EPLCG displays the error code that occurred on the last attempted communication with the PLC on that port. When the EPLCI is pinned for nonredundant communications, the error codes will be the same as those posted in the Box Status Display at the US when the Hiway Status display indicates DEV FAIL. If pinned for redundant communications and only one port has failed, the Box Status Display will show no error code. Since the EPLCI can still see the PLC through the remaining port, it will not indicate a DEV FAIL status and the Box Status Display will not show an error. However, the Last Error Code for the failed port will show an error. This error code will appear in the byte related to the failed port (upper byte for Port 1, lower byte for Port 2). See Table 5-2 for error codes and possible problem explanations. If there was no error the display will be zero. As soon as a message without error is transferred the display becomes zero. The relationship of memory addresses to PLCs is the same as with the PLC Error and Retry Counters above.

### 4.3.3 View Words

The view codes are displayed in memory addresses 1730-1737 (PLC Index 1-8, respectively) and pertain primarily to the redundant communications option and are intended for the maintenance technician's use. See Figure 4-3.

Notice that bit positions 02, 05, 08, and 11 have been zero-padded to break the word into 3-bit fields to facilitate reading the octal display. The normal view word is 002230(8).

If the redundant communications option has been enabled, View Word information is used to determine port selection and recovery without system software or operator intervention. Before queuing a message to a PLC, the EPLCG examines the Experimental routing flags. If these flags are nonzero, the message is queued to the indicated port(s). If the Experimental bits are zero, the EPLCG uses the Current routing flags. If the Current routing flags are also zero, the firmware queues the message to both ports.

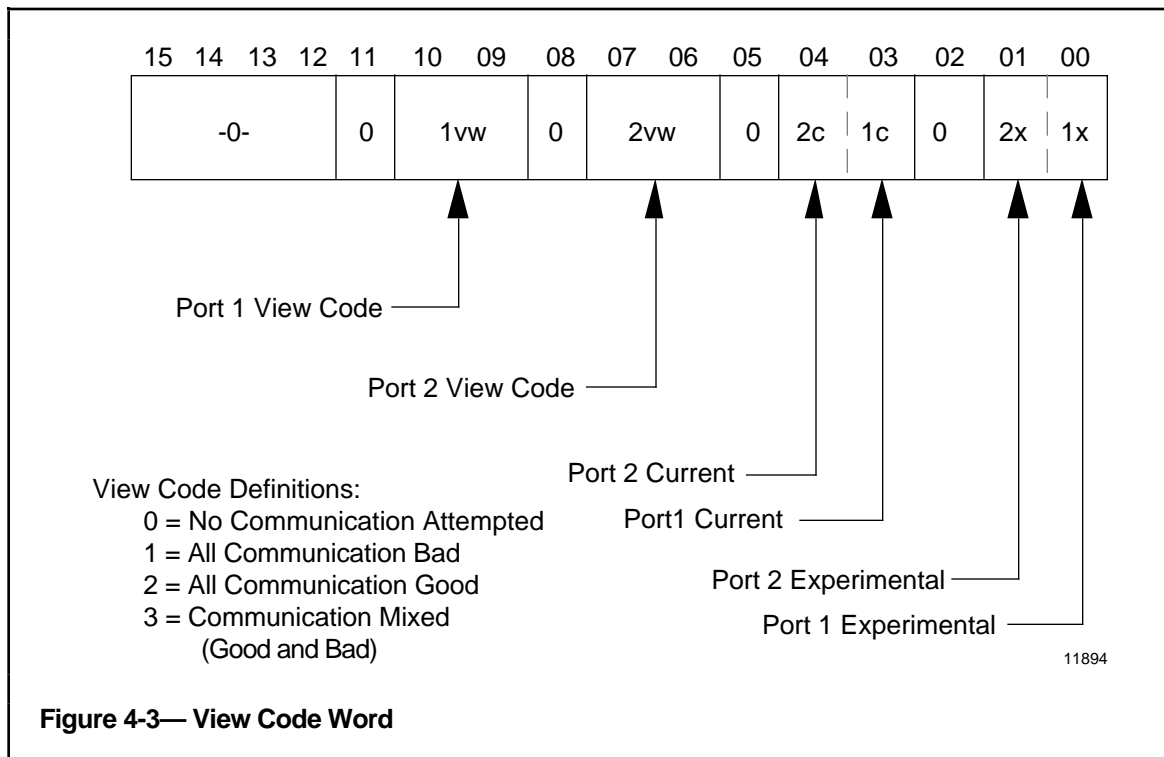

Bit 00 -- This bit set indicates that the EPLCI firmware is attempting an experimental reconnect to this PLC through Port 1.

Bit 01 -- This bit set indicates that the EPLCI firmware is attempting an experimental reconnect to this PLC through Port 2.

Bit 03 -- This bit set indicates that the EPLCI firmware is currently routing messages to this PLC through Port 1.

Bit 04-- This bit set indicates that the EPLCI firmware is currently routing messages to this PLC through Port 2.

Bits 06-07 -- These 2 bits contain the EPLCI's last known view of this PLC through Port 2. At the completion of each scan, the EPLCI examines the results of communication attempts to this PLC. If no accesses were attempted, the last known view is not modified. If accesses were performed, the results of these accesses are saved in this field at the end of each scan.

Bits 09-10 -- These 2 bits contain the EPLCI's last known view of this PLC through Port 1. At the completion of each scan, the EPLCI examines the results of communication attempts to this PLC. If no accesses were attempted, the last known view is not modified. If accesses were performed, the results of these accesses are saved in this field at the end of each scan.

As each message is processed, the Experimental routing flag is reset for that port. If no error occurs, the Current routing flag for this port is set and a port idle timer for this PLC is set to 15 seconds and started. If the timer expires, the Experimental bit for the port is set, to force communications. The idle timer guarantees that each port will be tried every 15 seconds. This allows more timely fault reporting on the unused port. Since a failed port will also be idle, the idle timer performs the function of a reconnect timer. Future messages to this PLC will be routed through the remaining port. If both Current routing flags are clear, the Experimental routing flag for the opposite port is set causing the EPLCG to alternate between the ports after both have had errors.

## 4.4 PORT STATISTICS

Statistics for both ports are provided as an approximate measure of EPLCG performance.

### 4.4.1 Subslots Processed Per Second

Each time the EPLCG processes a subslot (parameter) assigned to a given port, a 16-bit counter is incremented and once per second the results are transferred to the emulated DHP database. The counter provides a measured (versus calculated) value of the number of subslots processed per second as seen by the EPLCG. The number of subslots processed during the last second before the transfer is then displayed in this location (1740/1750) for the respective port.

#### NOTE

Although TDC 3000 System software treats a composite tag as a single data point, its implementation requires the use of 2, 3, or 4 subslots in the EPLCG. Since the EPLCG must collect the data for each subslot in use, EPLCG performance must be measured and compared in subslots (parameters) per second. If you wish to convert to TDC tags per second from subslots per second, you must use a correction factor which expresses the number of subslots per TDC tag. To calculate the correction factor, use the equation below. If the system being measured contains any composite TDC tags, the correction factor will have a value less than one.

$$\frac{\text{SUBSLOTS}}{\text{TIME}} \times \frac{\text{overall TAG count}}{\text{overall SUBSLOT count}} = \frac{\text{TAGs}}{\text{TIME}}$$

6364

### 4.4.2 Number of Messages Transmitted/Second

This location (1741/1751) contains the number of complete messages transmitted through this port in the previous 1-second period.

### 4.4.3 Number of Messages Received/Second

This location (1742/1752) contains the number of complete messages received through this port in the previous 1-second period.

#### 4.4.4 Number of Bytes Transmitted/Second

This location (1743/1753) contains the number of bytes transmitted through this port in the previous one- second period. It includes all control, header, trailer, and BCC/CRC bytes. Multiplying this parameter by 11 (1 start bit + 8 data bits + 1 parity bit + 1 stop bit = 11) and dividing by the port's baud rate will yield an approximate indication of port utilization, on transmit, as a fraction of the baud rate selected for this port (bandwidth used).

#### 4.4.5 Number of Bytes Received/Second

This location (1744/1754) contains the number of bytes received through this port in the previous one- second period. It includes all control, header, trailer, and BCC/CRC bytes. Multiplying this parameter by 11 (1 start bit + 8 data bits + 1 parity bit + 1 stop bit = 11) and dividing by the port's baud rate will yield an approximate indication of port utilization on receive (bandwidth used).

#### 4.4.6 Number of Scan Buffers Processed/Second

This location (1745/1755) contains the number of scan buffers processed in the previous second.

#### 4.4.7 Number of Keepalive Buffers Processed/Second

This location (1746/1756) contains the number of times, in the previous second, that the EPLCG built and sent a Keep Alive "refresh" message for this port.

#### 4.4.8 Number of Output Buffers Processed/Second

This location (1747/1757) contains the number of times, in the previous second, that the EPLCG built and sent a User Output message for this port.

#### 4.4.9 Firmware Freetime/Second Counters

These three counters (1760-1761, 1762-1763, 1764-1765) display approximations of EPLCI processor free time. The MINIMUM value indicates the least free time per second on record, which equates to the heaviest loading. The MAXIMUM value indicates the most free time per second on record, which equates to the lightest loading. The CURRENT value indicates the free time during the previous 1-second period.

#### 4.4.10 Number of Unsolicited Buffers Processed/Second

This location (1766 for Port 1, 1767 for Port 2) contains the number of times, in the previous second, that the EPLCG processed an unsolicited write (exception reporting) from the Port. When this location is zero, the PLCs on a given port are not transmitting unsolicited messages to the EPLCG. These counters are active even if the PLCs are configured for scan mode. The EPLCG will always accept an unsolicited message from an Allen-Bradley PLC.

#### 4.4.11 Number of Output FIFO Entries Available

These locations (1770 and 1771) contain the number of entries available in each of the two Port output FIFOs by port number. If the FIFO is empty, the value 40(8) (32 in decimal, each FIFO's maximum) is displayed. If the FIFO is full, the value 0 is displayed. In redundant communications mode, only the Port 1 FIFO is used. In this mode, events from the Port 1 FIFO are removed and distributed to both ports based on port loading and the current state of the port routing bits. See subsection 4.3.3, View Words, for port routing bit definitions.

### 4.5 DIGITAL INPUT STATUS POINTS

The EPLCG provides a total of eleven system visible Digital Input points. These points are located in slot 31 of each emulated DHP and are updated once per second. To prevent conflict with user-configured points, the following conditions must be met:

1. The emulated DHP must be processing (on-scan).
2. Slot 31 must be configured as a digital input slot.
3. Each port status digital input subslot must be configured as an empty subslot (word 0 and bit 0 for Allen-Bradley or address 0 and specifier 0 for ModBus).

To make these digital input status points visible to the TDC 3000 System, a tag must be built for each point. The tag's name can be anything the user wishes. Once built, the digital input status points can be referenced by tag name anywhere the system allows a digital input point.

#### 4.5.1 Port Status

Both a service bit and a failure bit are provided for each port. If the service bit is set, it indicates that at least one PLC cannot be reached through this port. If the failure bit is set, it indicates that none of the PLCs can be reached on this port. The table below shows the relationship between the subslot and its use in port status indication:

Subslot 16 = Primary EPLCG port 1 failure  
 Subslot 15 = Primary EPLCG port 1 service  
 Subslot 14 = Primary EPLCG port 2 failure  
 Subslot 13 = Primary EPLCG port 2 service  
 Subslot 12 = Backup EPLCG port 1 failure (Allen-Bradley only)  
 Subslot 11 = Backup EPLCG port 1 service (Allen-Bradley only)  
 Subslot 10 = Backup EPLCG port 2 failure (Allen-Bradley only)  
 Subslot 09 = Backup EPLCG port 2 service (Allen-Bradley only)  
 Subslot 08 = Best View Failover (Allen-Bradley only)  
 Subslot 07 = Port 2 Output FIFO Overflow  
 Subslot 06 = Port 1 Output FIFO Overflow

### 4.5.2 Best View Failover

Once per second, redundant EPLCGs running the Allen-Bradley communications protocol compare their PLC visibility. If the number of PLCs visible to the Backup EPLCG exceeds the number of PLCs visible to the Primary EPLCG for 20 consecutive seconds, the Backup EPLCG will order a Primary EPLCG shutdown. The Primary's shutdown will transfer system access to the Backup EPLCG which, in turn, provides a better PLC view to the system. To alert the operator when this type of failover occurs, the Backup EPLCG will set the Best View Failover status point. This alerts maintenance personnel to direct their attention to the communication networks between Primary EPLCG and the PLCs.

### 4.5.3 Port Output FIFO Overflow

The EPLCG also indicates the state of the Port Output FIFOs by way of a pair of Status Inputs. When the firmware attempts to transfer an output event into a Port Output FIFO, but the FIFO is already full, the corresponding overflow status input will be set true. The point will remain set until the firmware successfully transfers the output event in the Port Output FIFO. Note that in Redundant Communications Mode, only the Port 1 Output FIFO is used. This guarantees that output events are dispatched in the order received.

This section presents service instructions unique to the EPLCG.

## 5.1 OVERVIEW

The Enhanced Programmable Logic Controller Gateway (EPLCG) is housed in a standard TDC 3000 Dual Node Module. A unique functional circuit board (EPLCI), an input/output card (EPLCI I/O), and a special interlink cable (51196074-100) for redundant EPLCGs have been added to this standard module.

This manual provides instructions to test, troubleshoot, and repair those components unique to the EPLCG. Troubleshooting, disassembly, and assembly procedures for the remaining Dual node module and its components are contained in the *Five/Ten-Slot Module Service* or *Dual Node Module Service* manual in the *LCN Service -I* binder.

Although cables are not considered ORU items, their part numbers are listed in subsection 5.5 for reference.

### 5.1.1 Module Configuration - Standard EPLCG

Board complement for a 2-slot node Dual Node:

Slot	Front	P/N	Rear	P/N
2	EPLCI	51400997-200	EPLCI I/O	51304812-100
1	K2LCN	51401288-100	KLCN_CA	51304542-100

Board complement for a 3-slot node Dual Node:

Slot	Front	P/N	Rear	P/N
3	EPLCI	51400997-200	EPLCI I/O	51304812-100
2				
1	K2LCN	51401288-100	KLCN_CB	51304544-100

### 5.1.1 Module Configuration - EC Compliant EPLCG

EC board complement for a 2-slot node Dual Node:

Slot	Front	P/N	Rear	P/N
2	EPLCI	51400997-200	EPLCI I/O	51304812-200
1	K2LCN	51401288-100	CLCN-A	51305072-200

EC board complement for a 3-slot node Dual Node:

Slot	Front	P/N	Rear	P/N
3	EPLCI	51400997-200	EPLCI I/O	51304812-200
2				
1	K2LCN	51401288-100	CLCN-B	51305072-300

## 5.2 FIELD ADJUSTMENT

There are no field adjustments for the EPLCG. When replacing a board, you may have to change some pins (or jumpers) on the board to make the board correspond with the counterpart it is replacing. Do not alter pinning on a board revision socket—the revision number might have changed on the newer board.

## 5.3 GENERAL TROUBLESHOOTING

Before investigating deeply into a problem, make some preliminary checks:

- Is power applied to the module? Check switches, fuses, and circuit breakers on all equipment to insure they are functioning.

### WARNING

#### **DO NOT REMOVE OR REPLACE CIRCUIT BOARDS WITH THE POWER ON.**

Do not remove, handle, or transport circuit boards without observing proper Electrostatic Discharge (ESD) procedures. To review ESD procedures, see the *LCN Site Planning* manual in the *LCN Site Planning & Installation* binder.

- Note that the functional boards can be accessed through the front of each module by removing the front cover. Inspect the confidence indicators on each processor (K2LCN) board and the EPLCI board. Check power supply and fan confidence indicators. Doublecheck the pinning on the EPLCI board (shown in subsection 3.2.3).
- The EPLCI I/O, KLCN\_CA or KLCN\_CB paddleboards are accessed from the rear of the module.

To isolate a failed board, power supply, fan assembly, or other Optimum Replaceable Unit (ORU), follow the service procedures provided in the *Five/Ten-Slot Module Service* manual or the *Dual Node Module Service* manual in the *LCN Service -1* binder.

## 5.4 EPLCI TROUBLESHOOTING

The EPLCI board has unique indicators on its front edge to offer confidence that the board is working, and to provide assistance in case of a failure. The board also communicates with the Universal Station to report software indications of hardware failures. This section explains the function of these hardware/software indicators and will guide you in finding a failure.

### 5.4.1 EPLCI Hardware Indicators

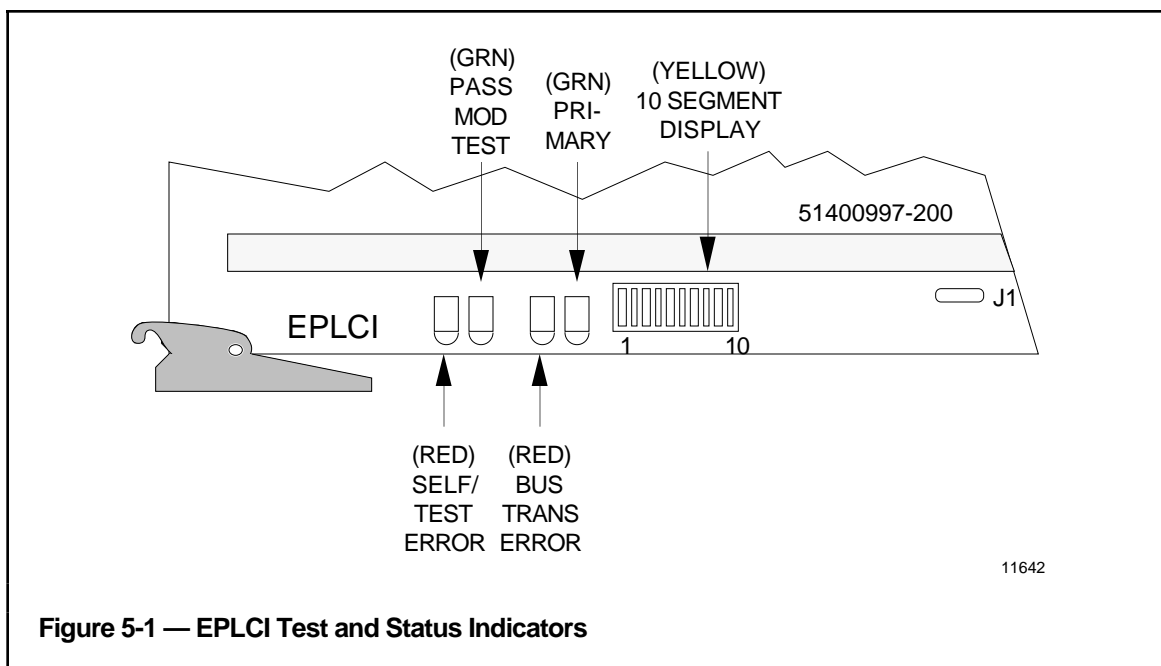

Figure 5-1 — EPLCI Test and Status Indicators

There are four LEDs located on the front left edge of the EPLCI board (see Figure 5-1). Each LED's definition and a brief description of its use follows. They are listed as shown in the figure, from left to right.

#### SELF-TEST or BOARD FAILURE (Red)

This LED lights under the following conditions:

- Module power coming on
- Module or EPLCI reset sequence working
- EPLCI self-test in progress
- Self-test failed
- Local parity errors

This LED is extinguished under the following conditions:

- Self-test is completed successfully
- Module or EPLCI reset sequence completed successfully
- EPLCI Abort Command sequence completed

#### PASSED MODULE TEST (Green)

This LED is lighted after the EPLCI successfully completes the CPU tests.

**TRANSACTION ERROR (Red)**

This LED lights under the following conditions:

- Module bus data parity error
- Bus error occurred during DMA access to module RAM

This LED is extinguished under the following conditions:

- Self-test is completed successfully
- Module power coming on
- Module or EPLCI reset completed
- EPLCI Abort Command in process

**PRIMARY EPLCI (Green)**

This LED is lighted when the EPLCI is on-line and functioning as the primary “HG.”

**10-SEGMENT DISPLAY (Yellow)**

Also, on the front edge of the EPLCI board, there is a 10-Segment display composed of yellow LEDs (see Figure 5-1). The function of each LED in this display, numbered 1 to 10 from left to right, are:

Segments 1, 2, and 3 monitor Port 1. Their functions are:

1. **TX RTS**—Illuminates when the transmit Request To Send is asserted.
2. **RX DATA**—Illuminates when Receive Data goes to a spacing condition.
3. **DSR/CD**—Illuminates when Data Set Ready and Carrier Detect are asserted.

Segments 4, 5, and 6 monitor Field Port 2. Their functions are:

4. **TX RTS**—Illuminates when the transmit Request To Send is asserted.
5. **RX DATA**—Illuminates when Receive Data goes to a spacing condition.
6. **DSR/CD**—Illuminates when Data Set Ready and Carrier Detect are asserted.

Segments 7, 8, and 9 are used at the factory. They have no use in field troubleshooting.

10. **REDUNDANT PARTNER**—Illuminates when the redundant partner is on-line.

## 5.4.2 EPLCI Hardware Indicator Troubleshooting Chart

Use Table 5-1 to aid you in determining the cause of a failure detected by the two fault indicators on the EPLCI.

**Table 5-1 — EPLCI Hardware Indicator Troubleshooting Chart**

INDICATION	POSSIBLE CAUSE	SOLUTION
<b>SELF-TEST ON</b> after power-up or reset sequence	Missing EPLCI I/O Paddleboard	Install EPLCI I/O Paddleboard in the correct slot behind EPLCI board.
	Failed EPLCI or EPLCI I/O Board	Substitute known good boards.
<b>SELF-TEST</b> goes OFF, then ON after the HG personality has been loaded	Incorrect Software Release	Check that Software Release 200 or later is being used.
	Incorrect Configuration	Check that emulated Data Hiway ports used are addresses 8 through 15.  Check that EPLCGs are configured for Hiway addresses 2 and 3.  Check that EPLCG is configured to perform the HTD functions.  Check for hardware configuration errors; reread subsections 2.4, 2.5, and 3.2 of this manual.
<b>TRANSACTION ERROR ON</b>	Memory Error	Substitute known good processor board(s).  If processor board(s) are OK, suspect the EPLCI itself.

### 5.4.3 EPLCI System Software Indications

System software indications that indicate hardware failures are presented in the Hiway Status display on the Universal Station (US). The Hiway Status display lists those brief error statements and codes and describes where they came from.

#### 5.4.3.1 Battery Failure

The Hiway Status display at the US (Universal Station) indicates BATT FAIL when a slot 16 failure has been posted from an emulated DHP. This does not indicate a battery failure—instead it has been used to show the **REDUNDANT PARTNER IS NOT ON-LINE**. This indication is only valid when the corresponding emulated DHP is enabled (on scan). The status of the redundant partner is also indicated by the 10-segment display—see subsection 5.4.1.

If you get this BATT FAIL indication when using a nonredundant EPLCG, recheck the EPLCI pinning in subsection 3.2.3.

#### 5.4.3.2 Device Failure

The Device Failure codes listed in Table 5-2 are posted in the Box Status Display at the US when the Hiway Status display indicates DEV FAIL. The error code presented at the US is in the form **11DC** where **D** = Device Number (PLC index) and **C** = Error Code in Table 5-2.

#### NOTE

Table 5-2 indicates Modbus protocol errors presented by Modicon controllers.

Other brands of controllers may not present the same errors as Modicon under the same circumstances, or may not present any error at all. Check the instruction manuals with your controller to verify the similarities and differences in error codes.

#### NOTE

PLC Communications Retry Guidelines:

Retries on transient communication errors will be performed for all messages, but timeouts are given special processing. The EPLCI will perform retries until three consecutive timeouts have accumulated against a PLC. Data collection from the PLC is suppressed for the remainder of the current scan. On the next scan it will attempt to collect the suspect PLC's data but with Timeout Retries still suppressed. If any response is received, even with an error, Timeout Retries are enabled and normal data collection attempts are resumed.

Infrequent transient errors will allow communications to be restored before three consecutive timeouts occur and will cause minimal impact on scan times. If communication cannot be reestablished, the EPLCI will wait for the next scan to try again. Retries are not allowed on certain errors where they are deemed unlikely to succeed. Each error code explanation in Table 5-2 indicates whether retries are allowed or not.

Table 5-2 — EPLCI Software Indication Troubleshooting Chart

CODE	FAILURE	POSSIBLE PROBLEM
1	Link Failure	<p>Communications protocol violation detected by EPLCI. Possible errors are Receive Buffer Overflow, Parity Error, Framing Error, etc. Retries allowed.</p> <p>A-B: Posted on receipt of local error code 03 or 04.</p>
2	Communications Timeout	<p>Verify by monitoring RX DATA and RTS indicators on indicated EPLCG field port (see subsection 5.4.1). Timeout indicated by RTS blinking while RX DATA is dark. Retries allowed. Possible causes are:</p> <ul style="list-style-type: none"> <li>• PLC cable disconnected or connected to wrong field port.</li> <li>• EPLCI pinning of baud rate/parity does not match PLC pinning.</li> <li>• DHP definition of PLC address does not match that at PLC.</li> </ul> <p>A-B: May also be local error code 02 or remote error codes 20 and 30. Also check DHP definition of PLC address—may not match that selected at the PLC.</p>
3	Configuration Failure	<p>The definition of a PLC (Modbus or A-B) unacceptable to the EPLCI. No retry. Possible causes are:</p> <ul style="list-style-type: none"> <li>• Assigned protocol conflicts with PLC.</li> <li>• The model code for a physical PLC conflicts with the model code already assigned to that physical PLC.</li> <li>• Any of the currently defined DHP configuration errors (see subsection 2.5 in the <i>EPLC Gateway Control Functions</i> manual in the <i>Implementation/EPLC Gateway</i> binder for hints on avoiding configuration errors).</li> </ul>
4	CRC Error	<p>The Cyclic Redundancy Check for a reply was incorrect. Retries allowed.</p> <p>A-B: Not used.</p>
5	Message Error	<p>The received reply was incorrect for the query sent. Retries allowed. Possible causes are:</p> <ul style="list-style-type: none"> <li>• Wrong PLC answered.</li> <li>• Reply size incorrect for number of parameters requested.</li> <li>• Message length inconsistent with message count byte.</li> </ul> <p>A-B: Posted on receipt of remote error code 10.</p>

(Continued)

Table 5-2 — EPLCI Software Indication Troubleshooting Chart (Continued)

CODE	FAILURE	POSSIBLE PROBLEM
6	Illegal Function	Modbus: Presented when the PLC returns the ILLEGAL FUNCTION exception code (01). No retry.  A-B: Not used.
7	Illegal Data Address	Modbus: Presented when the PLC returns the ILLEGAL DATA ADDRESS exception code (02). No retry. See subsection 2.5 in the <i>EPLC Gateway Control Functions</i> manual in the <i>Implementation/EPLC Gateway</i> binder for hints on avoiding configuration errors.  A-B: Posted on receipt of remote error code 50 or 80.
8	Illegal Data Value	Modbus: Presented when the PLC returns the ILLEGAL DATA VALUE exception code (03). No retry.  A-B: Not used.
9	Device Fault	Modbus: Presented when the PLC returns the FAILURE IN ASSOCIATED DEVICE exception code (04). No retry.  A-B: Posted on receipt of remote error code 40.
A	Entered Program Mode	Modbus: Presented when the PLC returns the PROGRAM ACKNOWLEDGE exception code (05). The EPLCG considers this response an error because the EPLCG cannot issue the PROGRAM command. No retry.  A-B: Posted on receipt of remote error code 70 or 80.
B	Busy/Insufficient Buffers	Modbus: Presented when the PLC returns the BUSY, REJECTED MESSAGE exception code (06). Retries allowed.  A-B: Posted on receipt of local error code 01 or remote error code 90.
C	NAK/Negative Acknowledge	Modbus: Presented when the PLC returns the NAK/NEGATIVE ACKNOWLEDGE exception code (07). No retry.  A-B: Not used.

(Continued)

Table 5-2 — EPLCI Software Indication Troubleshooting Chart (Continued)

CODE	FAILURE	POSSIBLE PROBLEM
D	Access Blocked	Modbus: Not used. A-B: Posted on receipt of remote error code 60.
E	Spare	Not used by either Modbus or A-B protocol.
F	Unspecified Error	Modbus: Not used. A-B: Posted on receipt of local errors 05 through 0F and remote errors A0 and C0 through F0.

### 5.4.3.3 Data Hiway Port Error Codes

The Device Failure codes listed in Table 5-2 do not show all error codes that may appear on the journals. Table 5-3 provides a list of the Data Hiway Port (DHP) error codes.

**Table 5-3 — Data Hiway Port Error Codes**

ERROR CODE	DISPLAY MNEMONIC	NAME	MEANING
1100	RESET	RESET	DHP in Reset
1100	WDT FAIL	DHP ERROR	Watch Dog Timer has expired
1101	DHP FAIL	WDT Expiration	Unknown Link Card in WDT Expiration
1102	DHP FAIL	Link Card CPU Test	Link Card CPU Test failure*
1103	DHP FAIL	Link Card ROM Test	Link Card ROM Test failure*
1104	DHP FAIL	Link Card RAM Test	Link Card RAM Test failure*
1105	DHP FAIL	Link Card Initialization Error	Link Card Initialization failure*
1106	DHP FAIL	Unknown Failure	Unknown Failure
to	↓	↓	↓
110F	DHP FAIL	Unknown Failure	Unknown Failure*
1191	BAT FAIL	Battery Failure	Memory Battery failure. This is a nonfatal failure; device status remains OK
1192	OVERLOAD	Processor Overload	Processor Overload
1193	SAVED	In Hard Save	Primary IPC HIM failure
1194	RC FAIL	RC Failure	Backup IPC HIM failure
1195	SF	Incorrect CPU Configuration	IPC HIM firmware not at proper revision
1196	UNDEFINE	Undefined Error	Probable cause is failure of box I/F card; Continuous Notification Writes from the box and no response to the HG callup.
1198	ALM FAIL	Box Reporting Failure Detected	Box reporting failure detected
1199	ALM FAIL	Box Reporting Failure Detected	Alarm reporting device changed
11A0...F	NULL	Box Error	Slot failures, 01-16
11B0...F	NULL	Box Error	Slot failures, 01-16
11BC	DEV FAIL (See Table 5-2)	Device failure	Device failure
	1 = Device Link Failure 2 = Device Box or Communications Failure 3 = Device Configuration Error 4 to F = Unknown Device Failure  Box Number		
	* Not applicable to Honeywell-620 HIM		

## 5.5 SPARE PARTS

Spare parts for the Five-Slot Module or the Dual Node Module and its components (fan, power supply, boards, etc.) are listed in the *Five/Ten-Slot Module Service* manual or in the *Dual Node Module Service* manual in the *LCN Service -1* binder.

Spare parts for the EPLCG are listed in Table 5-4.

**Table 5-4 — Parts List**

PART NUMBER	DESCRIPTION	
51201420-001	CABLE ASSY	PLCI I/O Board to Relay Panel, 1 meter
51201420-002	CABLE ASSY	Secondary PLCG I/O to Relay Panel, 2 meter
**51196072-100	CABLE	EPLCI I/O Debug Port Loopback Assembly
51196074-100	INTERLINK CABLE	EPLCI to EPLCI for Redundant EPLCGs
* 51304812-100	EPLCI I/O ADAPTER	EPLCI Paddleboard
51195096-100	PLCI ADAPTER	PLCI Paddleboard
51304514-100	RS232 DATA CABLE	EPLCG Port to Modem or CIM Cable
* 51304542-100	KLCN_CA	LCN A Cable Interface Converter Board
* 51305072-200	CLCN-A	CLCN A Cable Interface Converter Board (EC )
* 51304981-100	CLCN-A	CLCN A Face-Plate (EC )
* 51304544-100	KLCN_CB	LCN B Cable Interface Converter Board
* 51305072-300	CLCN-B	LCN B Cable Interface Converter Board (EC )
* 51304982-100	CLCN-B	CLCN B Face-Plate (EC )
* 51400997-200	EPLCI	Enhanced Programmable Logic Controller Interface Board
* 51401551-200	K2LCN-2	Processor/LCN Board/2Mw Memory
* 51304421-100	PLCG RELAY PANEL	PLCG Relay Panel
* 51304421-200	PLCG RELAY PANEL/EC	PLCG Relay Panel for EC
51190516-100	RELAY, SOLID STATE	Optically Isolated Relay
51190526-100	RELAY, DC, GEN PUR	High-Reliability Relay

\* ORU Level Replacement Item

\*\* Factory Use Only



---

# Index

---

Topic	Section Heading
AC Voltage Options	2.3.1
Allen-Bradley CIM Pinning	3.2.8.2
Assembly and Cabling	3.2
LCN Node Pinning	3.2.2
Module Installation	3.2.1
EPLCG Cabling	3.2.6
EPLCG Relay Panel Pinning	3.2.5
EPLCI Pinning	3.2.3
Baud Rate and Parity (TS2)	3.2.3.3
Board Revision (TS1)	3.2.3.2
Program Options (TS3)	3.2.3.4
Ram Clear (J1)	3.2.3.1
Port Cabling and Pinning for Modems Using Modbus Protocol	3.2.6
Modem Cable	3.2.6.1
Modem Pinning	3.2.6.3
Modem Wiring	3.2.6.2
Port Cabling for Direct Connection to Modbus Equipment	3.2.7
Port Cabling for Equipment Using Allen-Bradley Protocol	3.2.8
Allen-Bradley CIM Pinning	3.2.8.2
Direct Connection to Allen-Bradley Controllers	3.2.8.1
Battery Failure	5.4.3.1
Best View Failover	4.5.2
Baud Rate and Parity (TS2)	3.2.3.3
Board Revision (TS1)	3.2.3.2
Cable Lengths	2.4.3.3
Communications and Performance Statistics	4.3
PLC Error and Retry Counters	4.3.1
Port Statistics	4.3.2
Firmware Freetime/Second Counters	4.4.9
Number of Bytes Received/Second	4.4.5
Number of Bytes Transmitted/Second	4.4.4
Number of Keepalive Buffers Processed/Second	4.4.7
Number of Messages Received/Second	4.4.3
Number of Messages Transmitted/Second	4.4.2
Number of Output Buffers Processed/Second	4.4.8
Number of Unsolicited Buffers Processed/Second	4.4.10
Number of Scan Buffers Processed/Second	4.4.6
Subslots Processed per Second	4.4.1
Configurations	2.4
MP-NEPLC1 Nonredundant Gateways	2.4.1
Nonredundant Configurations	2.4.1.1
MP-REPLC1 Redundant Gateways with A-B Redundant Comm	2.4.3
MP-REPLC1 Redundant Gateways	2.4.2
Redundant Gateway Configurations	2.4.4
Current in Amperes at 120 Vac	2.3.3
Device Failure	5.4.3.2
Digital Input Status Points	4.5
Best View Failover	4.5.2
Port Status	4.5.1
Port Output FIFO Overflow	4.5.3
Dimensions and Weight	2.2.1

---

# Index

---

Topic	Section Heading
Direct Connection to Allen-Bradley Controllers	3.2.8.1
Direct-Connection	2.4.3.4
Electrical Requirements	2.3
AC Voltage Options	2.3.1
Current in Amperes at 120 Vac	2.3.3
Frequency	2.3.2
Electronics Checks	4.1.1
EPLCG Cabling	3.2.6
Port Cabling and Pinning for Modems Using Modbus Protocol	3.2.7
Modem Cable	3.2.7.1
Pinning	3.2.7.3
Modem Wiring	3.2.7.2
Port Cabling for Direct Connection to Modbus Equipment	3.2.8
Port Cabling for Equipment Using Allen-Bradley Protocol	3.2.9
Direct Connection to Allen-Bradley Controllers	3.2.9.1
Allen-Bradley CIM Pinning	3.2.9.2
EPLCG Relay Panel Pinning	3.2.4
EPLCG to PLC Connections	2.6
Modem Usage and Selection	2.6.1
Nonredundant EPLCG Port Connections	2.6.2
Redundant EPLCG Port Connections	2.6.3
EPLCI Pinning	3.2.3
Baud Rate and Parity (TS2)	3.2.3.3
Board Revision (TS1)	3.2.3.2
Program Options (TS3)	3.2.3.4
Ram Clear (J1)	3.2.3.1
EPLCI Hardware Indicator Troubleshooting Chart	5.4.2
EPLCI Hardware Indicators	5.4.1
EPLCI System Software Indications	5.4.3
EPLCI Troubleshooting	5.4
EPLCI Hardware Indicator Troubleshooting Chart	5.4.2
EPLCI Hardware Indicators	5.4.1
EPLCI System Software Indications	5.4.3
Battery Failure	5.4.3.1
Device Failure	5.4.3.2
European Compliance (EC)	1.2
Installation of EPLCI I/O Board (EC Compliant)	3.2.4
EPLCG Relay Panel (EC Compliant)	3.2.5.1
Field Adjustment	5.2
Firmware Freetime/Second Counters	4.4.9
Frequency	2.3.2
General Description	1.1
General Troubleshooting	5.3
Honeywell Support Services	1.3
Installation Wrap-Up	3.3
LCN Node Pinning	3.2.2
Limitations	2.5
Cable Lengths	2.5.3
Direct-Connection	2.5.4
Physical Limitations	2.5.1
Single vs Multi-Drop Cabling	2.5.2

---

# Index

---

Topic	Section Heading
Modem Cable	3.2.6.1
Modem Pinning	3.2.6.3
Modem Usage and Selection	2.5.1
Modem Wiring	3.2.6.2
Module Installation	3.2.1
Non-Redundant Configurations	2.4.1
Non-Redundant EPLCG Port Connections	2.5.2
Number of Bytes Received/Second	4.3.2.5
Number of Bytes Transmitted/Second	4.3.2.4
Number of Keepalive Buffer Misses/Second	4.3.2.7
Number of Messages Received/Second	4.3.2.3
Number of Messages Transmitted/Second	4.3.2.2
Number of Output Buffer Misses/Second	4.3.2.8
Number of Processing Buffer Misses/Second	4.3.2.10
Number of Scan Buffer Misses/Second	4.3.2.6
Overview	5.1
Physical Limitations	2.4.3.1
PLC Error and Retry Counters	4.3.1
PLCG Relay Panel Pinning	3.2.5
Port Cabling and Pinning for Modems Using Modbus Protocol	3.2.7
Port Cabling for Direct Connection to Modbus Equipment	3.2.8
Port Cabling for Equipment Using Allen-Bradley Protocol	3.2.9
Port Statistics	4.4
Power-On Tests	4.1
Electronics Checks	4.1.1
Program Options (TS3)	3.2.3.4
Ram Clear (J1)	3.2.3.1
Redundant Configurations	2.4.2
Redundant EPLCG Port Connections	2.5.3
Related Publications	1.4
Single vs. Multidrop Cabling	2.5.2
Site Requirements	2.2
Dimensions and Weight	2.2.1
Spare Parts	5.5
StartUp	4.2
Storage Conditions	2.1
Subslots Processed per Second	4.3.2.1
Unpacking	3.1



# READER COMMENTS

Honeywell IAC Automation College welcomes your comments and suggestions to improve future editions of this and other publications.

You can communicate your thoughts to us by fax, mail, or toll-free telephone call. We would like to acknowledge your comments; please include your complete name and address

**BY FAX:** Use this form; and fax to us at (602) 313-4108

**BY TELEPHONE:** In the U.S.A. use our toll-free number 1\*800-822-7673 (available in the 48 contiguous states except Arizona; in Arizona dial 1-602-313-5558).

**BY MAIL:** Use this form; detach, fold, tape closed, and mail to us.

Title of Publication: **EPLCG Planning, Installation, and Service** Issue Date: **9/95**

Publication Number: **EP02-500**

Writer: **C. Phillips**

**COMMENTS:** \_\_\_\_\_  
\_\_\_\_\_  
\_\_\_\_\_  
\_\_\_\_\_  
\_\_\_\_\_  
\_\_\_\_\_  
\_\_\_\_\_  
\_\_\_\_\_

**RECOMMENDATIONS:** \_\_\_\_\_  
\_\_\_\_\_  
\_\_\_\_\_  
\_\_\_\_\_  
\_\_\_\_\_  
\_\_\_\_\_  
\_\_\_\_\_

NAME \_\_\_\_\_ DATE \_\_\_\_\_  
TITLE \_\_\_\_\_  
COMPANY \_\_\_\_\_  
ADDRESS \_\_\_\_\_  
CITY \_\_\_\_\_ STATE \_\_\_\_\_ ZIP \_\_\_\_\_  
TELEPHONE \_\_\_\_\_ FAX \_\_\_\_\_

(If returning by mail, please tape closed; Postal regulations prohibit use of staples.)

Communications concerning technical publications should be directed to:

Automation College  
Industrial Automation and Control  
Honeywell Inc.  
2820 West Kelton Lane  
Phoenix, Arizona 85023-3028

FOLD

FOLD

From: \_\_\_\_\_  
\_\_\_\_\_  
\_\_\_\_\_



NO POSTAGE  
NECESSARY  
IF MAILED  
IN THE USA

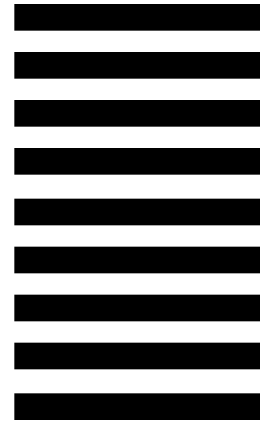

Cut Along Line

**BUSINESS REPLY MAIL**  
FIRST CLASS      PERMIT NO. 4332      PHOENIX, ARIZONA

POSTAGE WILL BE PAID BY ....

**Honeywell**

Industrial Automation and Control  
2820 West Kelton Lane  
Phoenix, Arizona 85023-3028

Attention: Manager, Quality

FOLD

FOLD

Additional Comments:



**Honeywell**

---

**Industrial Automation and Control**  
Honeywell Inc.  
16404 North Black Canyon Highway  
Phoenix, Arizona 85023-3099

*Helping You Control Your World*