

Experion R300 Fault Tolerant Ethernet

Table of Contents

- Product Introduction 2
 - Fault Tolerant Ethernet (FTE) 2
 - FTE Architecture Overview 3
 - Network Services 4
- Product Specifications 5
 - Fault Tolerant Ethernet Software 5
 - Dual Network Interface Controller (NIC) 5
 - Ethernet Cables 5
 - Overview of Switches 6
 - Switch with 24 Copper Ports 6
 - Switch with 48 Copper Ports 6
 - Advanced Switch with 24 Copper Ports 6
 - Ruggedized Switch with 12 Copper Ports 6
 - Switch with 12 SFP Ports 7
 - Small Form Pluggable Modules (SFP) 7
 - Ethernet Copper / Fiber Optic Media Converter 7
- Service Specifications 8
 - FTE Architecture Consulting Service 8
 - Firewall Design Service 9
- Topologies and Configuration Examples 11
- Model Number Summary 13

Product Introduction

Fault Tolerant Ethernet (FTE)

FTE is the control network for Experion. FTE provides multiple communication paths between nodes, enabling an FTE network to tolerate all single faults and many multiple faults. FTE is dedicated to the control mission- providing not only fault tolerance but also the performance, determinism, and security required for industrial control applications.

FTE unites Honeywell's expertise in designing robust control networks with commercial Ethernet technology in a patented advanced networking solution. While FTE is not a general purpose Information Technology (IT) network due to its control mission, it leverages commercial Ethernet technology to lower the costs of the FTE network infrastructure, connections to IT networks, connections to 3rd party Ethernet devices, and on-going maintenance and support.

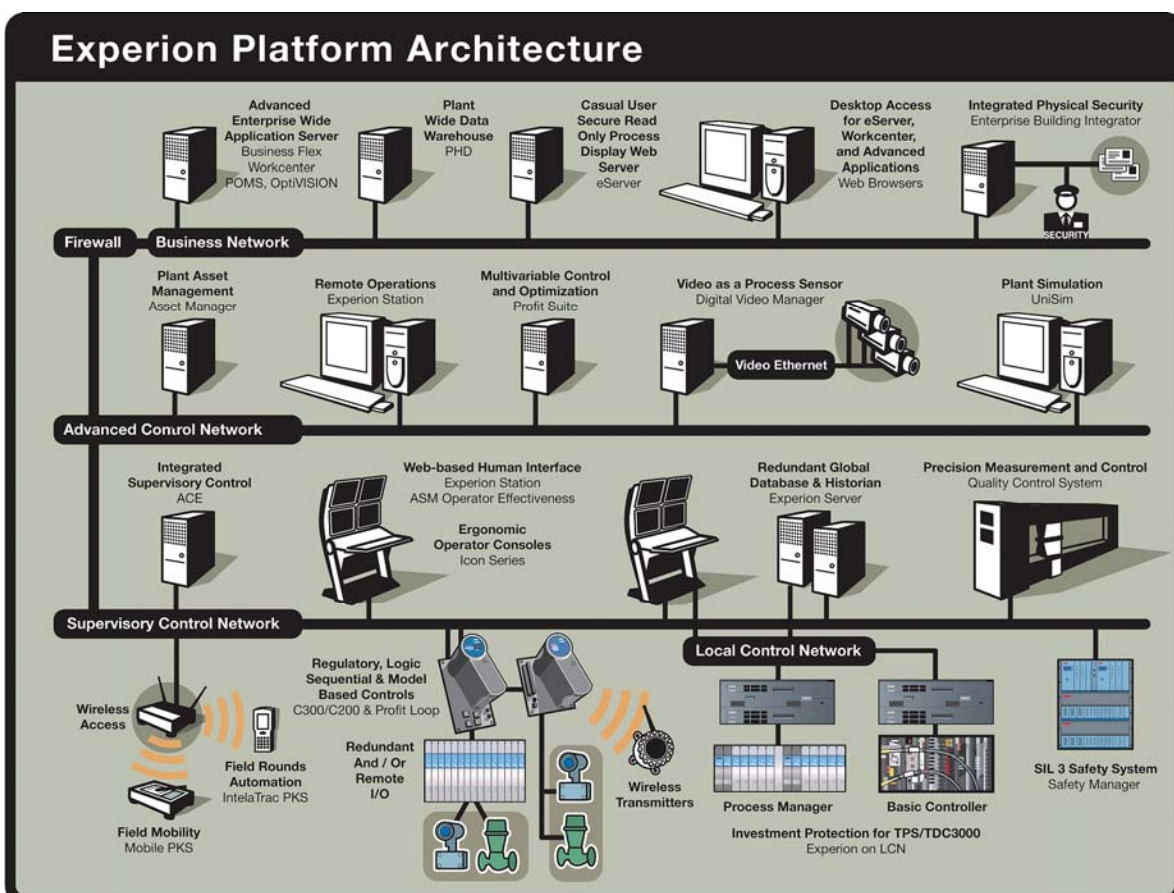

An FTE network is implemented through FTE nodes that contain FTE software, and appropriately configured switches. Normal Ethernet nodes (no FTE software) can also connect to an FTE network and benefit from its highly available communications environment.

FTE software is included with Honeywell computer platforms, and is embedded in Honeywell FTE-based control products. FTE software runs at a low level in the operating system of a computer and is transparent to higher-level application software, so all Honeywell application products as well 3rd party applications can run on FTE-enabled Honeywell computer platforms.

FTE Architecture Overview

An Experion system has one or more clusters--a group of nodes associated with the same server, e.g., Level 1 nodes like controllers, and Level 2 nodes like operator stations and servers. FTE provides multiple communication paths through two parallel trees of switches and cables; an FTE node connects to each tree. FTE nodes form a fault-tolerant community whose members can communicate if at least one path exists between them. FTE nodes detect Ethernet nodes and use any available path to communicate with them also. FTE management software may be installed on Ethernet nodes, so that their status can also be displayed by the Experion system.

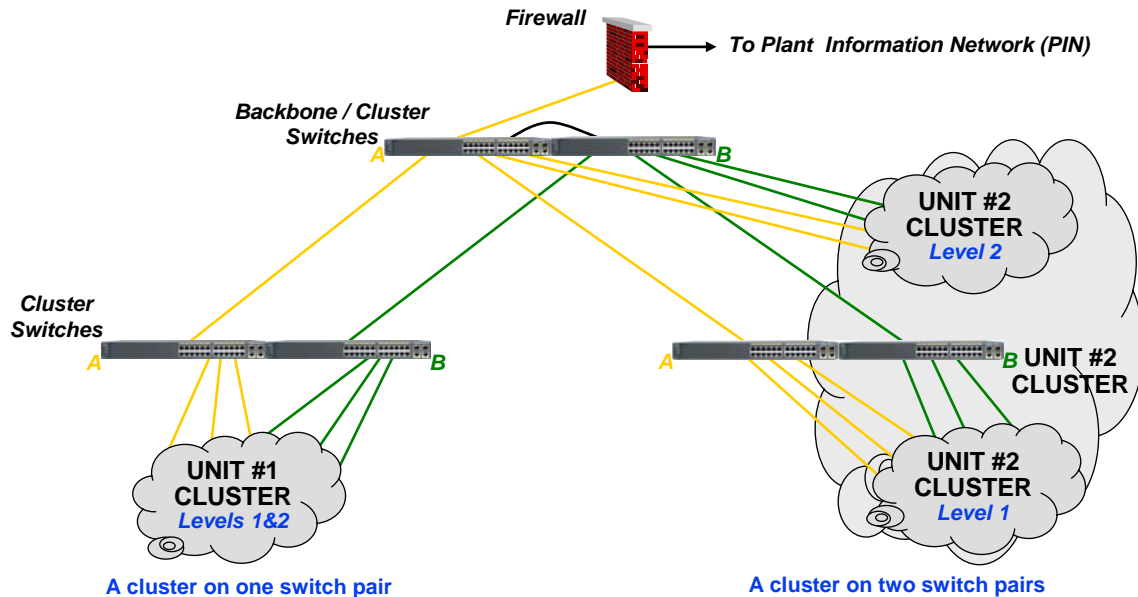

Figure 2: Basic FTE Network Architecture

For reliable operation in high noise industrial environments, Honeywell recommends fiber optic cables and shielded copper cables. FTE network security is designed in, layer by layer, through switch configuration files, the Series C Control Firewall, and best practice recommendations. Honeywell's network services organization can provide consulting, installation, and support services for firewalls, routers, and other network components, and can certify additional network equipment that may be used in project applications.

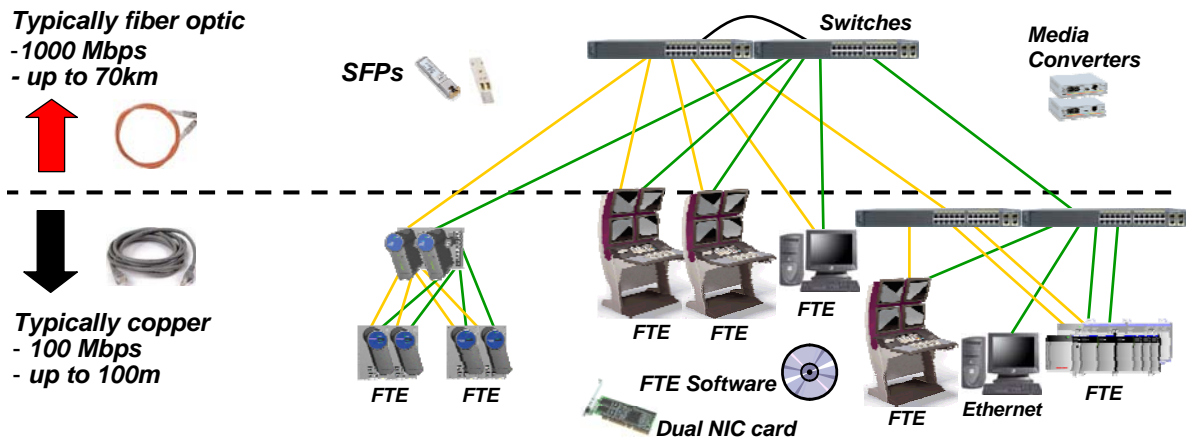

Figure 3: FTE Network Equipment

Network Services

Honeywell offers outstanding network services through Project Services and Open System Services. Their capabilities range in scope from a small Experion system to a total enterprise:

- Network planning, design, installation, and integration -- including all cabling, racks, testing, training, and documentation.
- Security assessment and engineering -- including authorization, authentication, encryption, activity logging, intrusion detection, and virus protection
- Firewall engineering, configuration, testing, and management -- providing secure remote access to a customer's network from anywhere in the world
- Remote monitoring of customer networks around the clock -- ensuring that all components are operating properly, including
 - networks (switches, routers, probes, firewalls)
 - systems (Experion, PlantScape, TPS, PHD, servers, any type of computer)
 - computers (Windows OS and applications running and responding)
- Network Performance Management -- supporting optimum operation by proactive tracking of network component performance
- Remote Network Administration -- ensuring correct installation of updates and configuration changes for components such as servers, switches, firewalls, and routers
- Procurement and support of computers and network equipment for consistent operation
- Services to test and certify equipment to be used in FTE networks.
- Firewall Design Service- provides a firewall device fully engineered and tested for networks of up to 50 connections. Firewalls for larger networks can be quoted on request.
- FTE Architecture Consulting Service- consulting and review on FTE network designs.



Product Specifications

Fault Tolerant Ethernet Software

NS-FTK000 Specifications	
FTE Nodes Supported	330 ¹
Ethernet (Non-FTE) Connections Supported	200
Network Topology	Parallel trees with up to 3 levels of switches, connected at the top.
Paths between FTE nodes	4
Paths between FTE and Ethernet nodes	2
Paths between Ethernet nodes	1
Typical Fault Switchover Time	0.5 second or less
Maximum Fault Switchover Time	3 seconds
Operating System Support	Windows 2000 Pro, XP Pro; 2000 Server Standard, Server 2003 Standard
Software Modules ²	FTE Driver; FTE Status Reporting; System Management Runtime
Computer ³ Software Licensing	NS-FTK000 is included with Honeywell computer platforms. FTE Status Reporting and System Management Runtime modules may be installed at no charge on Ethernet (non-FTE) nodes connected to the FTE network.

¹ 200 if any FTE Bridge nodes are present.

² FTE Driver provides the fault tolerance functions. FTE Status Reporting and System Management Runtime modules report a node's status to other nodes in the network.

³ A computer that is to have FTE Driver installed must be certified for FTE. Windows 2003 Domain Controller can be an FTE node, but Windows 2000 Domain Controller must run on a computer with one Ethernet port (Microsoft limitation).

Dual Network Interface Controller (NIC)



NE-NICS01 Specifications	
Model	Intel® PRO/1000 MT Dual Port Server Adapter
Number of Ports	2 10BASE-T / 100BASE-TX
Wiring and Connectors	CAT-5 copper, 2 pair; two RJ-45

Ethernet Cables



51305482 Copper Cable Specifications	
10/100/1000 Mbps	CAT5 ScTP, yellow or green color code, RJ-45 connectors

51305786 Copper Crossover Cable Specifications	
One crossover cable is required per FTE network, to interconnect the highest-level switch pair.	
10/100/1000 Mbps	CAT5 ScTP (Screened Twisted Pair), white color code, RJ-45 connectors

Available up to 20m length. Longer copper cables, or fiber optic cables, should be obtained as needed on a project basis.

Honeywell recommends fiber optic cables or shielded copper cables, either ScTP (Screened Twisted Pair), which consists of multiple pairs with an overall shield, or STP (Shielded Twisted Pair), which consists of multiple pairs with individual shields plus an overall shield. Experion nodes operate at 10 or 100Mbps. Honeywell offers shielded CAT 5 cable that provides operation up to 1Gbps; shielded CAT6 cable, which provides operation up to 10Gbps, may also be used.

Overview of Switches

Switches have ports for devices plus uplink ports for SFP (Small Form Pluggable) modules. Switches can be interconnected using either device ports or uplink ports.

For ease of installation, downloadable files are provided with different switch configurations for implementing best security practices: all L1 devices, all L2 devices, or a “split” L1|L2 configuration with separate L1 and L2 sections (NE-SW224S, NE-SW248S, NE-SW324S only).

Switch with 24 Copper Ports



NE-SW224S	
Model	Cisco Catalyst™ 2960-24TC-L*
Number of Ports	24 100/100BASE-T ports; 2 uplink ports either SFP or 10/100/1000T
Cabling/Connector Type	CAT5 copper, RJ-45 connector
Power	100-240 VAC (auto-ranging), 50-60 Hz
Operating Temperature	0 to 45°C (32 to 113°F)

* For further information, see Cisco data sheet.

Switch with 48 Copper Ports



NE-SW248S	
Model	Cisco Catalyst™ 2960-48TC-L*
Number of Ports	48 100/100BASE-T ports; 2 uplink ports either SFP or 10/100/1000T
Cabling/Connector Type	CAT5 copper, RJ-45 connector
Power	100-240 VAC (auto-ranging), 50-60 Hz
Operating Temperature	0 to 45°C (32 to 113°F)

* For further information, see Cisco data sheet.

Advanced Switch with 24 Copper Ports

Supports special configurations



NE-SW324S	
Model	Cisco Catalyst™ 3560-24TS-S
Number of Ports	24 10/100BASE-T ports; 2 SFP ports
Cabling/Connector Type	CAT5 copper, RJ-45 connector
Power	100-240 VAC (auto-ranging), 50-60 Hz
Operating Temperature	0 to 45°C (32 to 113°F)

* For further information, see Cisco data sheet.

Ruggedized Switch with 12 Copper Ports



NE-SW512C	
Model	Cisco Catalyst™ 2955C-12
Number of Ports	12 10/100BASE-T ports plus 2 100BASE-FX ports
Copper Cabling/Connector Type	CAT5 copper, RJ-45 connector
Fiber Cabling/Connector Type	50/125 or 62.5/125 multimode fiber optic, MT-RJ connector
Power	24vdc (18v min., 32v max.); dual input
Operating Temperature	-40 to 60° C (-40 to 140° F)

* For further information, see Cisco data sheet.

Switch with 12 SFP Ports



NE-SW312S	
Model	Cisco Catalyst™ 3750G-12S-S
Number of Ports	12 SFP ports**
Cabling/Connector Type	(per SFP type)
Power	100 to 127/200 to 240 VAC (auto-ranging), 50 to 60 Hz
Operating Temperature	0 to 45°C (32 to 113°F)

** Up to 9 switches can be interconnected ("stacked") to form one logical switch with up to 108 SFP ports. For further information and required stacking cables, see Cisco data sheet.

Small Form Pluggable Modules (SFP)



SFP modules are used for interconnecting switches. Cisco offers over 20 types for the above FTE switches. 1Gbps SFP types include:

- 10/100/1000BASE-T SFP, 100m copper (*Cisco GLC-T*)
- 1000BASE-SX SFP, 550m multimode fiber (*Cisco GLC-SX-MM*)
- 1000BASE-LX/LH SFP, 10km single mode fiber (*Cisco GLC-LH-SM*)
- 1000BASE-ZX SFP, 70km single mode fiber (*Cisco GLC-ZX-SM*)

100Mbps SFP types, useful for uplinks from Control Firewalls and NE-SW512C switches, include:

- 100BASE-FX SFP, 2km multimode fiber (*Cisco GLC-GE-100FX*)
- 100BASE-FX SFP, 2km multimode fiber (*Cisco GLC-FE-100FX*)**
- 100BASE-LX10 SFP, 10km single mode fiber (*Cisco GLC-FE-100LX*)**

** available for NE-SW224S and NE-SW248S only

SFPs and other accessories for switches, such as rack mounting kits and stacking cables, are available from Cisco and Cisco distributors.

Ethernet Copper / Fiber Optic Media Converter



NE-EMC001*	
Model	Allied Telesyn AT-MC102XL with power supply
Number of Ports	1 100BASE-TX (copper), 1 100BASE-FX (fiber)
Copper Cable / Connector / Distance	CAT5 copper; RJ-45 100 m
Fiber Cable / Connector / Distance	50/125 or 62.5/125 (core/cladding) MMF; Dual SC 2 km
Power	100-240 VAC, 50/60 Hz +/- 3%
Operating Temperature	0 to 40°C (32 to 104°F)

* Two are required at a node (one each for Tree A and Tree B). If that node connects to switches with 100BASE-TX copper ports, then two more are required at the switches (one each for Tree A and Tree B).

For further information, see AlliedTelesyn data sheet.

Honeywell offers NE-EMC001 since 100 Mbps on MMF is the most common application need. There are many other media converters on the market for different speeds, distances, and cable types; e.g., FTE Bridge would require a 10 Mbps converter. Media converters may be selected on a project basis; no certification is required since they do not affect FTE or Experion functions.

Service Specifications

FTE Architecture Consulting Service

NS-FTEA05, NS-FTEA20	
Overview	Fault Tolerant Ethernet (FTE) is an integral component of Experion PKS. Since FTE is based on open networking technologies that allow many possible configurations, proper FTE design and implementation are essential to the performance and security of an Experion system. The FTE Architecture Consulting Service helps Honeywell customers successfully achieve a FTE installation that adheres to Honeywell-tested best practices.
Key Features	<p>The FTE Architecture Consulting Service provides Honeywell FTE network consultants to review a proposed FTE network design. This offering helps customers understand FTE design requirements along with best practices for network security. Additional service offerings are available for network security assessment, design, implementation, and management.</p> <p>The customer's network design process typically includes several tasks for which Honeywell FTE network consultants could lend technical advice, such as:</p> <ul style="list-style-type: none"> • Business needs analysis and strategic planning • Tactical planning and scope definition • Identification of required network resources and their locations • Network integration design • Network topology design • Network cable plant design
Deliverables	<p><i>Primary Honeywell responsibilities include:</i></p> <ul style="list-style-type: none"> • Provide telephone consulting to review a proposed FTE network design <ul style="list-style-type: none"> ○ Technical exchange meetings during the design phase ○ Design review ○ Best practice awareness ○ Design strategies to meet communication needs <p>NS-FTEA05 – up to 5 hours of consulting NS-FTEA20 – up to 20 hours of consulting (These models can be ordered in amounts as needed for each project, e.g., for 10 hours of consulting, order 2 x NS-FTEA05.)</p>
Scope limitations	<ul style="list-style-type: none"> • On-site consulting and review by a Honeywell FTE network consultant is not included. This option can be added (priced separately, based on site location). • A one-month lead-time normally is sufficient for scheduling this service.
Customer responsibilities	Provide information on the proposed FTE network architecture.

Firewall Design Service

NS-FDS000	
Key Firewall Features	<ul style="list-style-type: none"> • Source and Destination Filtering – Controls which nodes on each side of the firewall may forward or receive packets through the firewall. • Protocol Filtering – Controls which network protocols are allowed to pass through the firewall, in either direction. • State Control of Communication – Controls which systems on each side of the firewall may initiate communications between networks. • Intrusion Detection – detects an attack, disconnects the session, logs the attack, and notifies the appropriate network security personnel. • Address Translation – Masks actual node addressing from systems outside the FTE network, for security and for flexibility in node addressing.
Deliverables	<p>Hardware/software: Honeywell will provide one firewall device with the capability of up to 20 nodes or 50 connections. A one-year maintenance agreement with the firewall manufacturer is included.</p> <p>Firewall design to meet customer security requirements: Honeywell will study customer requirements to complete a comprehensive design, including reliability and capacity needs and Service Level Agreements.</p> <p>Order all equipment required: During the design phase, a list of required equipment is generated. Honeywell then orders this equipment, and tracks it for timely delivery. Honeywell will specify the hardware required and be responsible for software-hardware compatibility and feature requirements.</p> <p>Stage and configure equipment to emulate customer environment: Honeywell will receive all equipment and verify that it is operational. Engineers will simulate the customer site's environment in a lab environment. Engineers will stage and configure all firewall parameters on all devices to work within customer requirements. Security checks performed will ensure that customer assets are not vulnerable to any unauthorized access. Once testing of the equipment and configurations is complete, the equipment will be shipped to the customer site. When the equipment arrives, the customer may call the Honeywell Solution Support Center (SSC) / Remote Service Center (RSC) for phone support while installing the equipment and bringing it on-line.</p> <p>Manage the connection (optional): Once the connection between the PCN and the PIN is provisioned, it can be moved to the operations group for management. Honeywell's SSC/Network Group (NG) offers additional services such as Availability Monitoring, Configuration Management, Fault & Vendor Management, Intrusion Detection and Performance Management, under separate contract.</p> <p>Post-Installation Support: Within the first 30 days, the Honeywell SSC/NG will be available to help troubleshoot, isolate faults, and make configuration corrections to the Firewall. For the first 60 days, Honeywell will accept configuration change requests.</p>

<p>Scope limitations</p>	<ul style="list-style-type: none"> • Honeywell services can design, configure, and implement security firewalls from a small LAN-to-LAN connection up through a complete Enterprise solution. The Firewall Design Service is a “starter level” service for a small LAN-to-LAN connection limited to creating a secure firewall connection for a PCN with a maximum of 20 nodes. For larger scale firewall needs or additional services, please contact your Honeywell Sales Representative. • Honeywell can provide an engineer to the customer site to install the equipment and do the final testing and implementation, under separate contract. • Configuration change requests for the first 60 days are limited to 8 hours of support. Additional support can be purchased. • Hardware: Honeywell will provide a firewall for up to 50 connections. No hardware or software other than the firewall is included within this package.
<p>Customer responsibilities</p>	<p>The customer must supply:</p> <ul style="list-style-type: none"> • A secure location for the firewall equipment, such as a cabinet or rack. • A single connection to the outside network within 15 feet of where the firewall equipment will reside. • A single connection to the FTE network within 15 feet of where the firewall equipment will reside. • All power and cooling for the firewall equipment. Typically two standard 110V power outlets are needed for the firewall equipment. • UPS power, if needed.

Topologies and Configuration Examples

Minimum FTE Network

1 cluster switch pair
All cables < 100 m

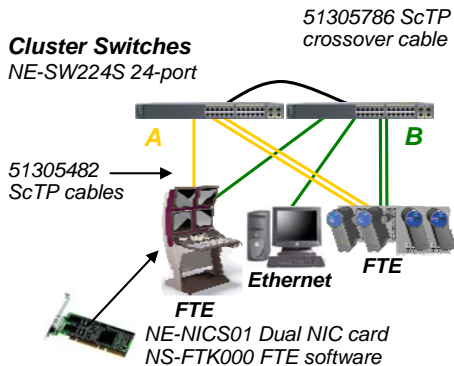

Figure 4: Minimum FTE Network

The following examples illustrate typical component model numbers for an FTE network. *They do not include software components and are not intended as the basis for placing an order.*

Figure 4 shows the simplest FTE topology—one pair of switches (with both cluster and backbone roles), a crossover cable, and cabling to FTE and Ethernet nodes. All distances from nodes to switches are less than 100 meters, so copper equipment and cabling can be used.

Any of the switch types can be used in the backbone role. Typically the backbone switches will also be used to connect nodes from one or more Experion clusters.

Figure 5 shows a small FTE network with three pairs of cluster switches. One node and one set of cluster switches are more than 100m from the backbone switches, so they are connected using multi-mode fiber optic cables and 100 Mbps media converters. Otherwise,

copper equipment and cabling are used. Alternatively, the switches could have been interconnected using 1000 Mbps SFP modules, but 100 Mbps is more bandwidth than this Experion system needs.

Media converters may be a more economical solution than SFPs, depending on the distances involved and other site factors. There are many media converters on the market for different speeds, distances, and cable types. Media converters may be selected on a project basis; no certification is required since they do not affect FTE or Experion functions.

Small FTE Network

3 cluster switch pairs
Some cables > 100 m

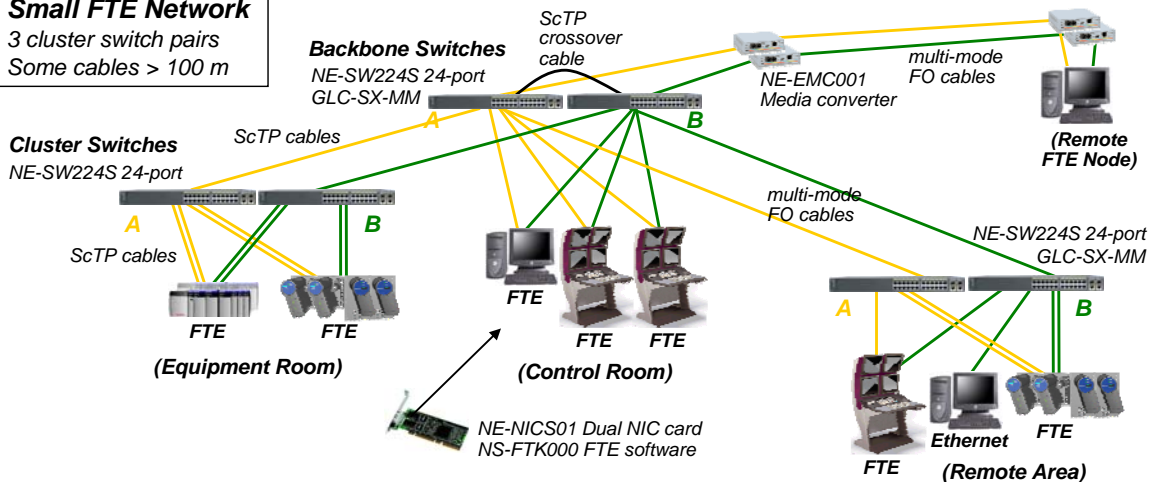

Figure 5: Small FTE Network

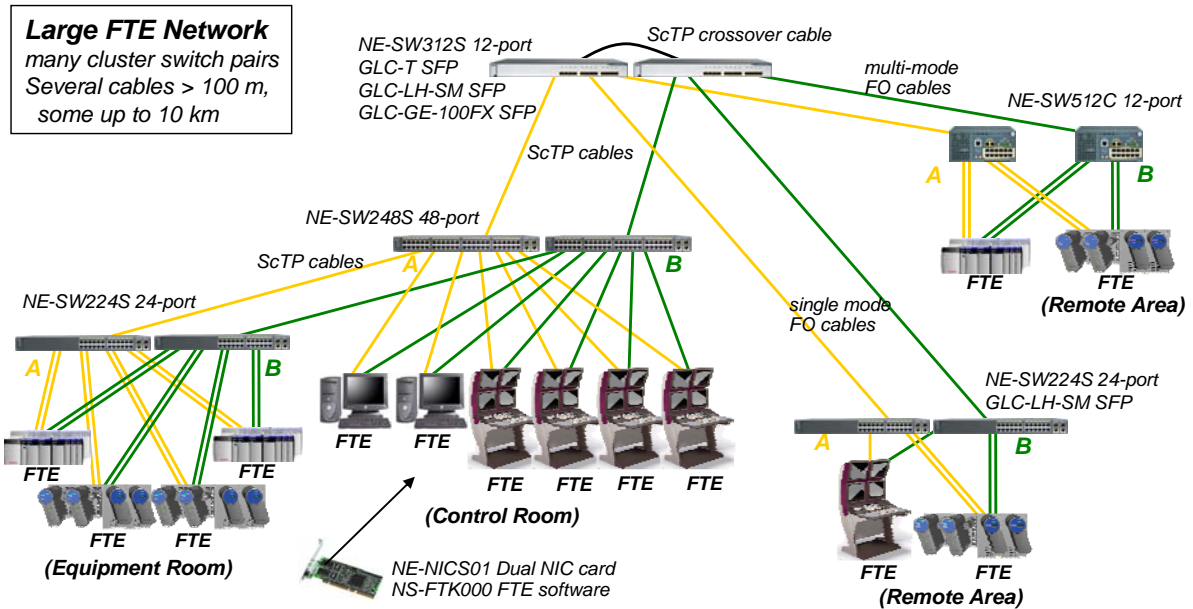

Figure 6: Large FTE Network

Figure 6 illustrates a large FTE network with 15-20 cluster switch pairs, some of which are shown. To accommodate a network of this size, NE-SW312S switches are used as the backbone switches, to interconnect cluster switches using appropriate SFP modules and multi-mode or single mode fiber optic cabling. NE-SW312S switches can have several types of SFP modules to interconnect cluster switches up to 70 km distant.

Many FTE network topologies are possible. For example, a large plant might have a single FTE network in which several remote clusters of controllers, each connected to a pair of cluster switches, are connected via fiber optic cables to a pair of backbone switches in a central control room, in which servers, stations, and other devices are also connected to the backbone switches.

Model Number Summary

FTE Software		
NS-FTK000	FTE software and FTE node license for computer	
Network Interface Controllers (NIC)		
NE-NICS01	Dual port 100 Mbps copper	
Switches		
NE-SW224S	24 10/100 BASE-T copper ports plus 2 uplink ports	
NE-SW248S	48 10/100 BASE-T copper ports plus 2 uplink ports	
NE-SW324S	24 10/100 BASE-T copper ports plus 2 SFP ports	
NE-SW312S	12 SFP ports	
NE-SW512C	12 10/100 BASE-T copper ports plus 2 100 BASE-FX ports	
Media Converter		
NE-EMC001	100 Mbps Ethernet media converter for copper to MMF up to 2 km	
ScTP CAT5 Cable with RJ-45 Connectors		
	Tree A– yellow coded	Tree B– green coded
2 meters	51305482-102	51305482-202
5 meters	51305482-105	51305482-205
10 meters	51305482-110	51305482-210
20 meters	51305482-120	51305482-220
ScTP CAT5 Crossover Cable with RJ-45 Connectors		White coded
2 meters		51305786-502
5 meters		51305786-505
10 meters		51305786-510
20 meters		51305786-520
Services		
NS-FDS000	Firewall Design Service	
NS-FTEA05	FTE Architecture Consulting Service, up to 5 hours	
NS-FTEA20	FTE Architecture Consulting Service, up to 20 hours	

*PlantScape® and TotalPlant® are registered trademarks and Experion™ is a trademark of Honeywell International Inc.
All other products and brand names shown are trademarks of their respective owners.*

While this information is presented in good faith and believed to be accurate, Honeywell disclaims the implied warranties of merchantability and fitness for a particular purpose and makes no express warranties except as may be stated in its written agreement with and for its customer. In no event is Honeywell liable to anyone for any indirect, special or consequential damages. The information and specifications in this document are subject to change without notice.

USA: Honeywell Process Solutions, 2500 W. Union Hills Dr., Phoenix, AZ 85027 /**Canada:** The Honeywell Centre, 155 Gordon Baker Rd., North York, Ontario M2H 3N7/**Latin America:** Honeywell, Inc., 480 Sawgrass Corporate Parkway, Suite 200, Sunrise, Florida 33325/**Japan:** Honeywell K.K., 14-6 Shibaura 1-chome, Minato-ku, Tokyo, Japan 105-0023/**Asia:** Honeywell Pte Ltd., Honeywell Building, 17 Changi Business Park Central 1, Singapore 486073, Republic of Singapore/**Pacific Division:** Honeywell Pty Ltd., 5 Thomas Holt Drive, North Ryde NSW Australia 2113/**Europe and Africa:** Honeywell S.A. Avenue du Bourget 3, 1140 Brussels, Belgium/**Eastern Europe:** Honeywell Praha, s.r.o. Budejovicka 1, 140 21 Prague 4, Czech Republic/**Middle East:** Honeywell Middle East Ltd., Technology Park, Cert Complex Block Q, Muroor Rd., Abu Dhabi, U.A.E.

Printed in U.S.A. — © Copyright 2006 - Honeywell International, Inc.
Honeywell Process Solutions
2500 W. Union Hills Drive
Phoenix, AZ 85027
(602) 313-5000

Honeywell