

Enhanced Programmable Logic Controller Gateway Control Functions

EP09-500

**Implementation
EPLC Gateway**

***Enhanced Programmable
Logic Controller Gateway
Control Functions***

**EP09-500
Release 520
7/96**

Copyright, Trademarks, and Notices

© Copyright 1995 by Honeywell Inc.

Revision 03 – July 15, 1996

While this information is presented in good faith and believed to be accurate, Honeywell disclaims the implied warranties of merchantability and fitness for a particular purpose and makes no express warranties except as may be stated in its written agreement with and for its customer.

In no event is Honeywell liable to anyone for any indirect, special or consequential damages. The information and specifications in this document are subject to change without notice.

TotalPlant is a U.S. registered trademark of Honeywell Inc.
Other brand or product names are trademarks of their respective owners.

About This Publication

This publication supports **TotalPlant**[®] Solution (TPS) System network release 500 - 520. TPS is the evolution of TDC 3000^X.

This is a reference manual for process engineers, control system engineers, and application engineers who design and implement data acquisition and control strategies to be accomplished through a TPS system with a Local Control Network. This publication defines the data acquisition and control functions that reside in Programmable Logic Controller Gateways and the Programmable Logic Controllers connected to the EPLCG.

This publication is a member of a set of publications that define control system functions. The other members of the set are: *System Control Functions*, *Process Manager Control Functions and Algorithms*, *Hiway Gateway Control Functions*, and *Application Module Control Functions*.

For the most effective use of this manual, you should be familiar with the concepts and terminology introduced in the *System Control Functions* manual.

Table of Contents

1 REFERENCES

- 1.1 References

2 EPLCG DATA ACQUISITION AND CONTROL FUNCTIONS

- 2.1 EPLCG Scope
- 2.2 Hiway States
- 2.3 DHP Status
 - 2.3.1 Run State
 - 2.3.2 Run-SF
 - 2.3.3 Run-PF
 - 2.3.4 Idle-SF, Idle-PF
 - 2.3.5 Fail-COM
 - 2.3.6 Fail-HDW
 - 2.3.7 Reset
 - 2.3.8 Uncertain
 - 2.3.9 DHP Control States
- 2.4 EPLCG Backup
 - 2.4.1 EPLCG Failover Scenario
- 2.5 EPLCG Parameter Configuration and Error Codes
 - 2.5.1 Avoiding Errors
 - 2.5.2 Errors on Input and Output Requests to PLCs
- 2.6 EPLCG Parameter Configuration
 - 2.6.1 Relating EPLCG Boxes and Slots to PLCs and PLC Addresses
 - 2.6.2 Reserved Entities
 - 2.6.3 Parameter Configuration
- 2.7 EPLCG Data Point Capacity
 - 2.7.1 Total EPLCG Point Capacity
 - 2.7.2 Composite Points in One Box
 - 2.7.3 Fifty Points with Critical Alarm Status
 - 2.7.4 Momentary ("Doorbell") Digital Points
 - 2.7.5 Analog Input Points
 - 2.7.6 Points with Event-Initiated Processing
 - 2.7.7 Contact-Cutout Secondary Points
- 2.8 Special EPLCG Functions
 - 2.8.1 Functions Related to Emulated DHPs
 - 2.8.2 Special Functions Related to Process-Connected Subsystems

3 DETAILED DATA POINT DESCRIPTIONS

- 3.1 EPLCG Analog I/O Data Points
 - 3.1.1 Analog I/O Point Types
 - 3.1.2 Functional Structure of Analog I/O Points
 - 3.1.3 Processing Order for Analog I/O Points
 - 3.1.4 First Level Processing of Analog I/O Points
 - 3.1.5 Second Level of Analog I/O Processing
 - 3.1.6 PV Source Selection for Analog I/O Points
 - 3.1.7 PV Range, PV Clamping Options, and PV Value Status
 - 3.1.8 Analog Output Data Point Modes
 - 3.1.9 Point Alarming for Analog Input Points

Table of Contents

3.1.10	Alarm Limits (PVLOTP, PVHITP, DEVLOTP, DEVHITP)
3.1.11	Event-Initiated Processing for Analog Input Points
3.1.12	Analog I/O Point Addressing
3.2	EPLCG Digital I/O Data Points
3.2.1	Digital Input Points
3.2.2	EPLCG Digital Output Data Points
3.2.3	EPLCG Digital I/O Composite Data Points
3.2.4	Digital Alarms
3.3	EPLCG Counter Data Points
3.3.1	Functional Structure, EPLCG Counter Point
3.3.2	Counter Functions
3.3.3	EPLCG Counter Parameters
3.3.4	EPLCG Counter Processing
3.4	EPLCG Hiway and Box/Slot Data Points
3.4.1	Hiway Point Parameters
3.4.2	Box/Slot Data Point Processing
3.4.3	Box/Slot Data Point Parameters
3.4.4	Box/Slot Point Names
3.5	Special Point Related Functions
3.5.1	Associated Display
3.5.2	Auxiliary Units

REFERENCES Section 1

This section provides references to other publications that are useful or necessary in implementing control system functions.

1.1 REFERENCES

This manual describes the data acquisition and control functions that reside in EPLCGs and the logical boxes that are in the EPLCGs. There are two companion publications:

- *System Control Functions*, in the *Implementation/Startup & Reconfiguration - 2* binder—describes data acquisition and control functions that are independent of the module or gateway they reside in.
- *Application Module Control Functions*, in the *Implementation/Application Module - 1* binder—describes data acquisition and control functions in Application Modules.

You should be familiar with the content of *System Control Functions* before using this publication or other control function publications.

Other topics related to data acquisition and control functions are covered in these publications:

- **Preparation of Control Language Programs**—First refer to the *Control Language/Application Module Overview*, in the *Implementation/Application Module - 3* binder. Then refer to the *Control Language/Application Module Reference Manual*, in the same binder. These manuals cover both continuous control programs that run in AMs and CL/MC programs that run in MCs.
- **Parameters**—For details on all of the data point parameters, including value types, default values, and access levels (keys), refer to the following publications:

EPLC Gateway Parameter Reference Dictionary, in the *Implementation/EPLC Gateway* binder.

Application Module Parameter Reference Dictionary, in the *Implementation/Application Module - 2* binder.

EPLCG DATA ACQUISITION AND CONTROL FUNCTIONS

Section 2

This section defines the data acquisition and control functions, other than data point functions, that are accomplished in a Enhanced Programmable Logic Controller Gateway (EPLCG). The data point functions are defined in Section 3.

The Enhanced Programmable Logic Controller Gateway (EPLCG) is an LCN node that provides a direct interface to any of several Programmable Logic Controllers (PLCs) available from various manufacturers. A single EPLCG can be connected through its two ports to up to 16 PLCs. The EPLCG database is organized into eight logical boxes as viewed by the LCN and the configuration software. The EPLCG may be provided as a redundant node pair, consisting of a primary EPLCG backed up by its redundant partner. Should the primary EPLCG fail, its partner takes over all of the failed node's functions, using the current database. The EPLCG's redundant communications configuration can also provide I/O network redundancy.

An EPLCG can handle up to 3,000 LCN data points of these seven types:

- Analog Input
- Analog Output
- Analog Composite
- Counter (timer)
- Digital Input
- Digital Output
- Digital Composite

Some LCN data points (composite points) use two or more memory locations in the EPLCG; therefore, when these types are used, the capacity is limited to 240 point database "slots."

Functionally, the EPLCG is similar to the Hiway Gateway (HG), and it operates on the HG software, as is, with no modifications. The EPLCG operates as if it were a Data Hiway with up to eight Data Hiway Ports (DHPs). All operating and configuration displays for EPLCGs are HG displays with no modifications, including the HG and DHP terminology.

DHPs are Data Hiway boxes (each an independent hardware module) that interface with PLCs. The EPLCG offers better performance because data is transferred through the EPLCG more quickly than over a Data Hiway and through DHPs.

2.1 EPLCG SCOPE

The EPLCG was designed primarily for data acquisition and supervisory-level control. In supervisory control schemes, the EPLCG provides intermittent bursts of set-point type data, while the PLC performs high-speed control sequencing.

A typical EPLCG/PLC control application can be depicted with a ten-motor conveyor belt. For proper operation, the startup/shutdown sequence of the individual motors must be precisely controlled. To start or stop the belt, an operator performs a single write from the EPLCG to the PLC. The PLC would then be responsible for performing the detailed operation that results in the desired change.

NOTE

Because the EPLCG emulates an HG with a Data Hiway and up to eight DHPs, all references to Data Hiways and DHPs (boxes) refer to the emulated devices (and to emulated slots and subslots), and not to physical devices. The term “slot” applies to the point memory space in the EPLCG, and the term “subslot” applies to the data points that are implemented in these slots.

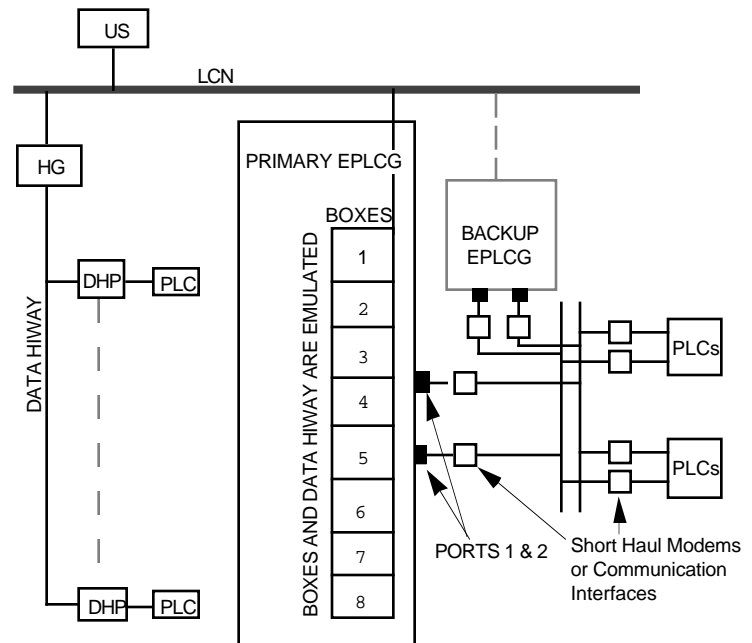

11567

2.2 HIWAY STATES

The operating states of the emulated hiway and DHPs are presented on the Network Status display for each EPLCG. While there is no Data Hiway connected to the EPLCG, it behaves as if there is a Data Hiway. Therefore, the emulated Data Hiway appears on the Network Status Display to be in one of these three states:

- Uncertain
- Running
- Failed

Initially, before Data Hiway security checks have been made, or when starting up a hiway without a database, the status of a emulated hiway is set to Uncertain.

In the running state, interfaces to the hiway are operational and normal communication over the hiway is possible. The Network Status display for each Data Hiway shows which logical hiway (A or B) is active.

Restart of a backup EPLCG does not cause a change in the hiway state. A failure in the EPLCG (both redundant EPLCGs) or the emulated hiway (A and B out of service) changes the hiway status to "failed."

2.3 DHP STATUS

The state of an emulated DHP is determined by the EPLCG, but only when the hiway is in the running state. If the hiway has failed, an access error indication is returned when the EPLCG tries to read from, or write in, an emulated DHP. The operational states for process-connected boxes are:

- Run *
- Run-SF (soft failure)
- Run-PF (partial failure)
- Fail-COM (Hiway Status diagnostic failure)
- Fail-HDW (hardware)
- Reset
- Uncertain

* A DHP enters the Run state when an operator at a Universal Station uses the Network Status display and box commands to tell it to do so.

2.3.1 Run State

The emulated DHP is fully operational; the hiway security check has qualified the box.

This state can be selected by the operator from the Reset state, if the box is operational and qualified.

2.3.2 Run-SF[†]

The emulated DHP is in Run and a soft failure has been detected.

2.3.3 Run-PF[†]

A partial failure has been detected in the emulated DHP. Some points are affected (their state is failed); unaffected slots operate normally.

2.3.4 Idle-SF, Idle-PF[†]

The emulated DHP is in the idle state and a soft failure (-SF) or a partial failure (-PF) has been detected.

2.3.5 Fail-COM

The emulated DHP failed the hiway security check, or an addressing error was detected. All communication to the DHP, except for hiway security tests, are inhibited. The functional status is set to Basic Control.

[†] Because there are no physical DHPs, this will not normally occur.

2.3.6 Fail-HDW[†]

The EPLCG has determined that the emulated DHP has failed; the functional state is set to Basic Control (read and write access from AMs and CGs is inhibited). This state can be set by only the EPLCG.

Box HDW Failure Definition—A box failure is the inability of the EPLCG to communicate with a specific DHP. With a real Hiway, this could be a result of communication errors other than those detected by the hiway security check, including no response, but is not likely to occur in a EPLCG. In such a situation, the EPLCG changes the state of the DHP to "failed." In the absence of such a condition, the EPLCG sets the state of the DHP to the one that is determined from the box status words.

2.3.7 Reset

The emulated DHP itself detected a fatal error and reset itself; the functional status is set to "basic control" and read or write access from an AM or CG is inhibited. One of the DHPs can also be commanded reset through the Box Commands function of the Hiway Status display.

2.3.8 Uncertain

The emulated DHP has not yet been qualified by the hiway security check and communication with it is inhibited. The functional status of the DHP is set to "out-of-service for control."

2.3.9 DHP Control States

The control states are Basic, Read, Full, and Test. (If you need more information, refer to subsection 3.3.8 in *System Control Functions*.) The emulated DHP's states can change from one state to any other; however, changes from Fail-COM, -HDW, and Uncertain force the functional status to Basic Control.

[†] Because there are no physical DHPs, this will not normally occur.

2.4 EPLCG BACKUP

2.4.1 EPLCG Failover Scenario

Switching from an active EPLCG to the backup is accomplished with as little disruption to control and data acquisition as possible. These two factors are very important in failover processing:

- Time-out handling
- Time to restore communication on the emulated Data Hiway.

It takes the backup one second to detect a failure in the active EPLCG. When it does detect a failure, it attempts to directly communicate with the active EPLCG. If this communication isn't reestablished within two seconds, the backup requests the error-handling subsystem to determine whether to replace the active EPLCG. While waiting for this replacement, the backup proceeds with the following two functions:

1. Hiway security checking is started by the backup, and the scanning of the points with the 50 most critical (emergency priority) alarms begins.
2. The time-out gates in the boxes are updated so that control shedding doesn't occur.

When the system error handler determines that the formerly active EPLCG has failed, failover processing continues. The total time to complete the failover is about five seconds.

As failover processing continues, the following takes place:

3. The backup (secondary) becomes active (primary).
4. All functions that receive event messages are notified that failover has occurred and the distribution of the highest-priority alarms begins.
5. Requests for data from the EPLCG are processed according to these priorities:
 - Control-function requests
 - Operator-initiated requests
 - Display updates
6. Alarms other than the 50 critical alarms are processed.
7. Remaining requests for data from the EPLCG are processed.
8. All remaining functions resume, including checkpointing of EPLCG data, history collection, and trending.

2.5 EPLCG PARAMETER CONFIGURATION AND ERROR CODES

After you have used the Data Entity Builder to build and load EPLCG points, you may encounter error codes for one or more emulated DHPs on the Operator Personality's Network Status display for the EPLCG's hiway. These errors are likely to be caused by configuration errors, such as incorrect PLC addresses.

2.5.1 Avoiding Errors

If you incorrectly define a EPLCG data point, the PLC may generate an "Illegal Data Address" during operation. This occurs because the point number is referencing a PLC point address which is not configured. These errors are sometimes difficult to isolate; however, once you have identified the troubled slot, you can disable the emulated DHP. This allows the Detail Displays access to the PLC database, and you can then search through the tagnames associated with the error.

To avoid these kinds of errors, it is a good idea to enter all PLC points and their corresponding **TotalPlant** Solution (TPS) System tagnames into a database program on a personal computer. The data can then be sorted in any way you need, and you'll be able to track which PLC points correspond to which tagnames. Remember to update the database anytime you make changes to the EPLCG configuration.

2.5.2 Errors on Input and Output Requests to PLCs

The EPLCG attempts to read all configured PLC data with every scan, but an error detected during a normal scan request is not shown on the Operator Personality's Network Status Display until retries also fail. The failed request will be retried two more times. If the error was only transient, the points and slots associated with that request will not indicate failure. If the error persists, the slots will fail and thereafter are checked once each scan to detect error correction.

When you attempt to change the state/value of a PLC point, you make an output request. Output requests have three sources:

- Operator changes
- Changes from an AM
- PLC keep-alive addresses

Because such requests can occur anytime, the system also performs a retry, if appropriate. The number of retries allowed is specific to the communications protocol in use. ModBus requests are retried twice, while Allen-Bradley requests are retried three times (as recommended by the vendors).

Please note that a retry is performed anytime there is a transient type error condition. Under certain conditions, such as configuration errors, retries do not alter the results and are, therefore, suppressed.

2.6 EPLCG PARAMETER CONFIGURATION

2.6.1 Relating EPLCG Boxes and Slots to PLCs and PLC Addresses

The PLCG must be configured in **this** order to work properly:

1. Hiway Points
2. Box Points
3. Data Points

Each EPLCG has up to eight emulated boxes (numbered 8-15) each of which contains up to 30 emulated slots and their subslots, allowing you to configure up to 3,000 points. Figure 2-1 illustrates how, for example, a digital input point named PDI001A would be configured:

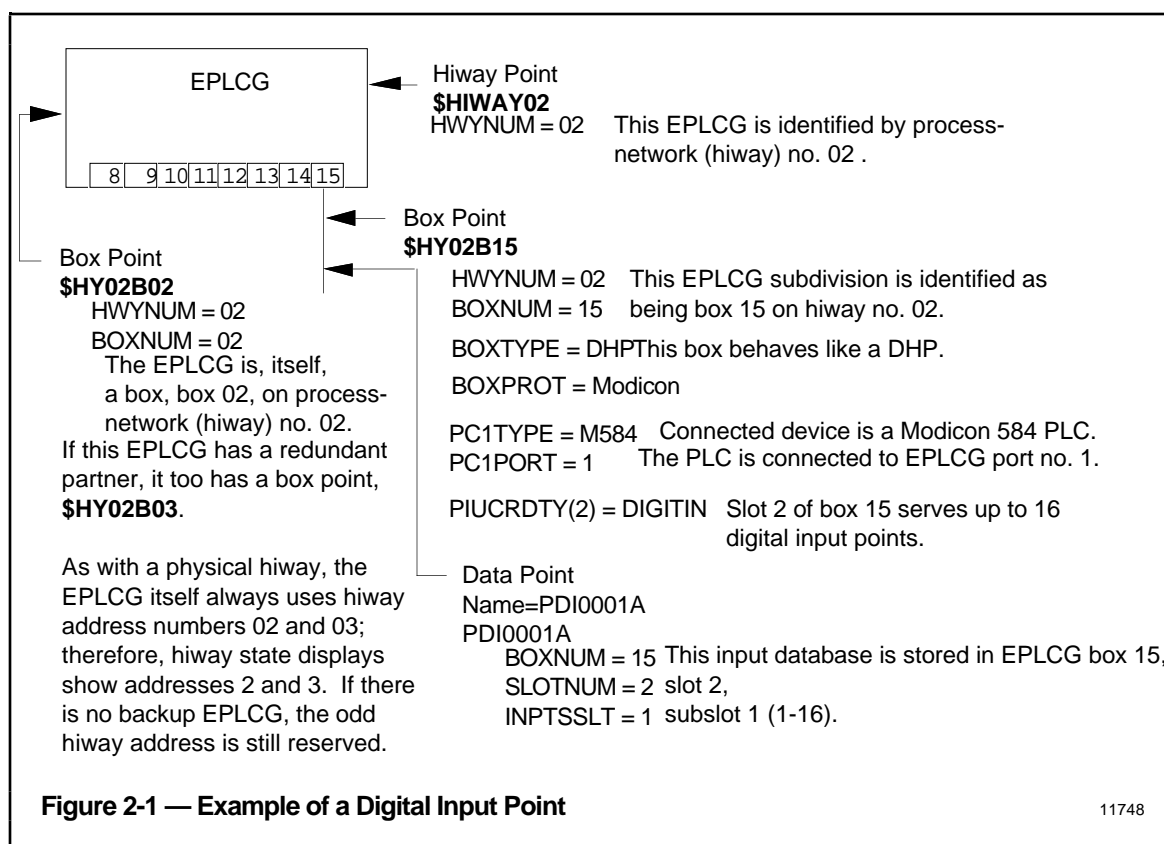

2.6.2 Reserved Entities

When configuring a PLC for the network, you must be sure to configure all required reserved entities. There are up to 11 reserved entities (names for reserved entities begin with \$). These reserved entities are:

- \$HIWAYnn** Hiway Point; one per EPLCG or EPLCG redundant pair.
 nn=network (hiway) number.

\$HYnnBnn (for EPLCG) Box Point; one per EPLCG or each partner of a EPLCG pair. The first nn=network (hiway) number and the second nn=box number (02, 03 for redundant EPLCG).

\$HYnnBnn (for emulated Hiway DHP Boxes) Box Point; one per emulated DHP. The first nn=network (hiway) number and the second nn=box number (08-15).

NOTE

Digital Composite and Analog Composite points exist in a PLC, but are not structured the same as corresponding Digital Composite and Analog Composite points in the PM/APM.

2.6.3 Parameter Configuration

Figure 2-2 shows the structure of the EPLCG as it relates to the parameters in the reserved entities and an example data point:

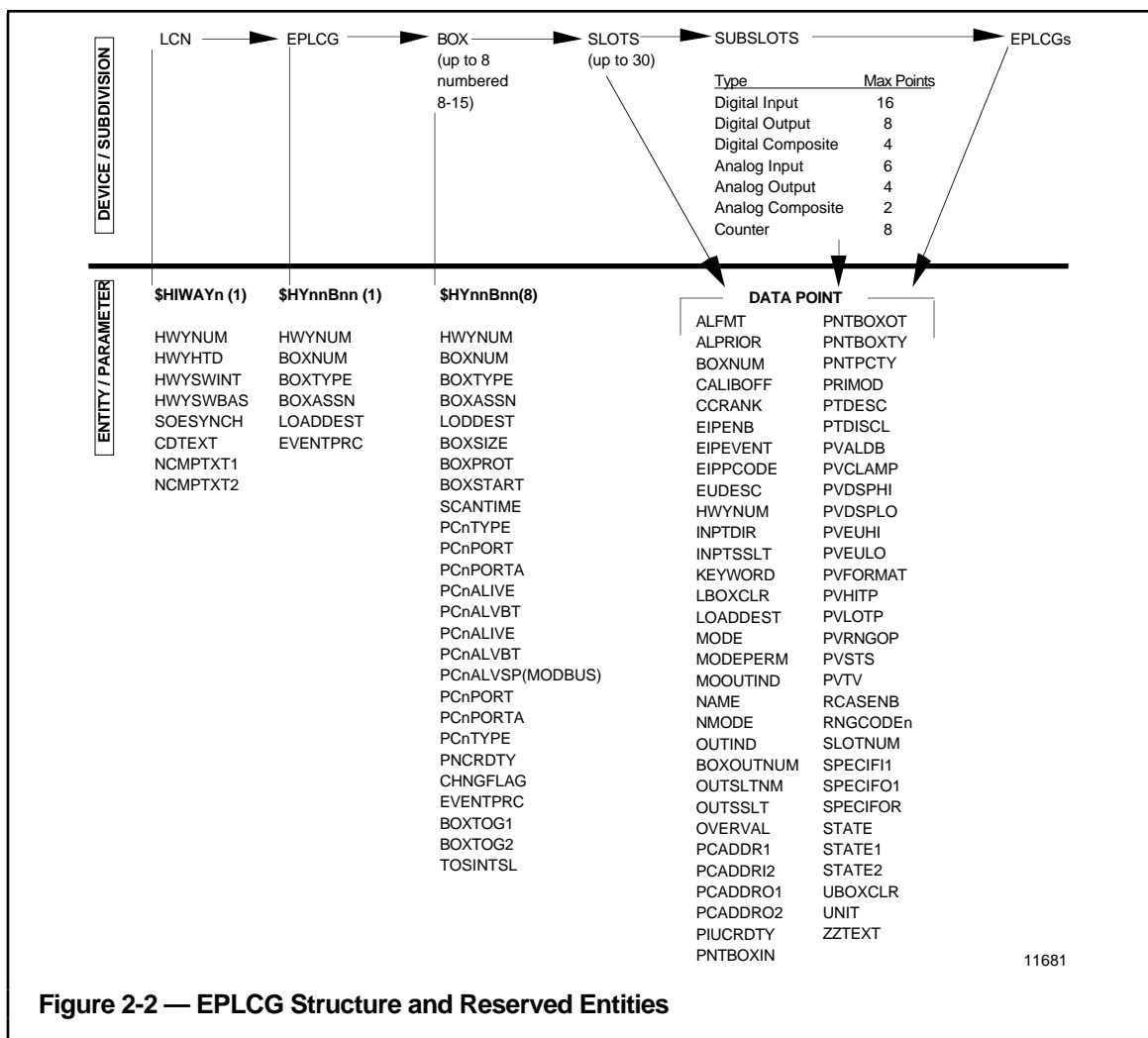

Figure 2-2 — EPLCG Structure and Reserved Entities

2.7 EPLCG DATA POINT CAPACITY

The following are configuration limits and restrictions that apply to EPLCG data points.

2.7.1 Total EPLCG Point Capacity

If you refer to the “MaxPoints” column under “Subslots” in the chart above, you can calculate that if all points were digital inputs, you could have as many as 16 digital inputs X 30 slots X 8 DHPs = 3,840 points in a EPLCG; however, the maximum number of data points that can be built for a EPLCG (or EPLCG pair) is 3,000. Each emulated DHP has 30 slots and each slot has 4, 6, 8, or 16 subslots, depending on the point type, as indicated on the chart above. Composite points consume more than one EPLCG memory location; therefore, the total point capacity is the lesser of 3,000 points or 240 slots of data.

2.7.2 Composite Points in One Box

Composite Analog I/O and Composite Digital I/O points must be configured for the same EPLCG and the same DHP (box). The input and the output cannot be in different boxes. For more information, see subsections 3.1 and 3.2.

2.7.3 Fifty Points with Critical Alarm Status

Up to 50 data points can be configured for critical alarms (ALPRIOR for such points is configured as Emergency). These points are specially checked on EPLCG startup or failover to see if an alarm has been detected during the failover operation. During failover, alarms that have a lower status than critical are not distributed. In normal operation, points with ALPRIOR = Emergency are scanned by the EPLCG at 1/2-second intervals.

2.7.4 Momentary ("Doorbell") Digital Points

EPLCGs can have up to 500 momentary or "doorbell" digital output points.

2.7.5 Analog Input Points

EPLCGs can have up to 1,440 analog input points.

2.7.6 Points with Event-Initiated Processing

EPLCGs can have up to 600 configured for event-initiated processing (EIP) points. (If you need more information, refer to subsection 4.2 in *System Control Functions*.)

2.7.7 Contact-Cutout Secondary Points

Up to 500 points can be configured as secondary cutout points. (If you need more information, refer to subsection 4.3.1.7 in *System Control Functions*.)

2.8 SPECIAL EPLCG FUNCTIONS

This subsection defines specific control functions that are performed by the EPLCGs. The purpose of the section is to clarify that though these functions may be covered elsewhere in the System, HG, and AM Control Functions publications, they are accomplished by the EPLCG.

2.8.1 Functions Related to Emulated DHPs

2.8.1.1 Startups

The EPLCG handles the necessary initialization for all emulated DHPs, with the exception of Clearance Hiway Security Errors (an address error on the Hiway Status Display). This error must be cleared by the operator.

2.8.1.2 Control Time-Out Function

For emulated DHPs, the EPLCG provides a time-out function similar to that of the Extended Controller. The box-level time-out gates are automatically updated by the EPLCG as long as the box is in the "full control" state, secondary points in the box are in CAS mode, and their primary points in an AM continue to supply new SP or OP values to their secondary points. In addition, each slot can be assigned (parameter TOGINTSL) to one of two time intervals configured for its box (BOXTOGn). These intervals are the time-out periods for the slot. A write to the SP or OP parameter of a point in a slot, resets the timer.

2.8.1.3 General Parameter Access

The EPLCG provides access to all accessible parameters in the emulated DHPs. The EPLCG returns an error indication if an invalid access request is made.

2.8.1.4 PV Source Selection

The EPLCG provides selection of PV sources for all analog input and digital input data points. While the PV source is manual or substituted, mode changes are inhibited. Access to the PV Auto value is available when the PV source is manual or substituted. Values of PV MAN and PV SUB are limited to the PV range. While the PV source is manual or substituted, PV alarms are inhibited. A bump in the PV can occur when changing from SUB to AUTO.

When PVSOURCE equals MAN or SUB, the manually entered or substituted PV value is held in the EPLCG, while the PV in the emulated DHP (visible at the LCN as PVAUTO) is unaffected. Alarm checking continues on the PV in the box.

2.8.1.5 Clamping

If PV clamping is configured for a data point (PVCLAMP = Clmp), clamping is handled by the EPLCG. For the full-range clamp option, the PV is clamped at -2.9% of the range when the variable goes below that value, and it is clamped at 102.9% if the variable goes above that value. A zero-clamp option is also available, where the PV is clamped at 0% of the range if the variable goes below that value.

2.8.1.6 Reverse-Acting Transmitter Handling

The EPLCG accommodates reverse-acting data from the PLC (see parameter OUTIND in the *EPLC Gateway Parameter Reference Dictionary*).

2.8.1.7 PV Value Status

Value status is assigned to all analog PVs by the EPLCG. A bad value status is assigned if the PV is outside the range and the extension and clamping is not configured, or if the PV is not available from the emulated DHP. The value status is uncertain when the PV is clamped or the PV source is other than auto. When the PV status is bad, the PV value is NaN (not a number).

2.8.2 Special Functions Related to Process-Connected Subsystems

2.8.2.1 Modicon Controllers and Modicon Emulators

The EPLCG can scan discrete status (digital inputs) that are “packed” in a register. Modicon controllers can affect this operation and possibly some emulator types. For this feature, 16 digitals may be packed into one 16 bit “holding” PLC register. The EPLCG must be configured with all 16 statuses in one slot. The slot must be a digital input type slot, but the address should be of the form 4xxxx, where 4 is the specifier and xxxx is the register address. Refer to *EPLC Gateway Forms* if you need more information.

The EPLCG may be configured to suppress the periodic scanning of analog or digital outputs from Modicon controllers. During configuration, create a logical Modbus PLC using Port No. = 3 or 4 on the actual Port 1 or 2, respectively. Then configure any nonscanned points against this logical PLC. If anyone attempts to configure an input point (analog, digital, or counter) against a nonscanning logical PLC, a configuration error will occur.

2.8.2.2 Allen-Bradley Controllers

The EPLCG may be configured to accept only binary data (registers or counters) from A-B PLC-3 or PLC-5 controllers by selecting type “APLC” during configuration. Any other selection means the data will be accepted only in BCD form. Refer to *EPLC Gateway Forms* if you need more information.

The PLC may be configured to accept data sent by A-B PLCs by unsolicited messages (scan suppression). During configuration, use Port No. = 3 or 4 to mean Port 1 or Port 2 with scanning suppressed. Actually, the EPLCG will accept unsolicited messages (exception reports) from A-B PLCs even if scanning, but if both the EPLCG and PLC is configured for it, scan suppression can increase throughput. Standard A-B Data Hiway rules apply. Configuration applies to each PLC definition (PC1, PC2, and so on.) for each emulated DHP. Definitions may mix access types from the same physical PLC. Refer to *EPLC Gateway Forms* if you need more information.

2.8.2.3 Keep-Alive Addressing

The EPLCG writes a 1 to the PLC every 10 seconds through its emulated DHP. By doing this, the EPLCG notifies the PLC that it is “alive.” If the EPLCG fails, it does not write the Keep-Alive address, a timer in the PLC expires, and the PLC knows that the EPLCG is down. The PLC can then take action, such as suspending batch operation, or sounding an external alarm. The action the PLC takes is programmed in the relay ladder logic. The 10-second Keep-Alive interval is fixed in the emulated DHP and cannot be changed. See subsection 3.3.2.2 in *Enhanced Programmable Logic Controller Gateway Implementation Guidelines* for “Keep-Alive addressing.”

DETAILED DATA POINT DESCRIPTIONS

Section 3

This section provides a definition of the functions of the seven types of EPLCG data points: digital input points, digital output points, digital composite points, analog input points, analog output points, and analog composite points.

3.1 EPLCG ANALOG I/O DATA POINTS

Analog I/O data points represent analog inputs from the PLC and analog outputs to the PLC. A composite analog I/O point provides one input and one output in the same data point.

3.1.1 Analog I/O Point Types

There are three types of analog I/O data points:

- Analog Input—one input from a PLC.
- Analog Output—one output to a PLC.
- Analog I/O Composite—one input and one output with the same tag name. The input slot (and subslot) and the output slot (and subslot) must be in the same emulated DHP.

3.1.2 Functional Structure of Analog I/O Points

- Analog input points have one input from a PLC and produce a PV with point status and PV status.
- Analog output points have one output (OP) with related status and mode parameters.
- Analog I/O composite points combine one analog input and one analog output in one data point with one tag name. They are intended to support displays and applications that use an output with position feedback. They have an output value with its status and an input PV with its status.

CAUTION

EPLCG users should bear in mind that inputs to, and outputs from, the EPLCG can be affected by the ladder logic in the PLCs. When interpreting the process information on Universal Station displays, operators, supervisors, and engineers must be aware of the effect of ladder logic on the process inputs and outputs. For example an operator could command a state change for a digital output, but the ladder logic might prevent that state change from reaching the process equipment. For this reason, normal operation of the EPLCG is to scan all output values from the PLC, as well as input values to provide value tracking.

3.1.3 Processing Order for Analog I/O Points

Because individual analog I/O data point functions reside in different memory locations and the functions are distributed between different software routines, there is no apparent processing order.

3.1.3.1 Analog I/O Point Parameter Descriptions

Refer to the *EPLC Gateway Parameter Reference Dictionary* for the full names, value ranges, default values, value types, and access levels for these parameters.

3.1.3.2 Number of Analog Inputs and Outputs

The number of inputs and outputs defines the type of analog tag to be built. One input and one output can be configured into the same tag. One input and no output is also allowed, as is one output and no input. Tags with no inputs or outputs are not allowed.

3.1.3.3 Data Acquisition

The configuration database is built by the EPLCG according to port, PLC address, and point address. When configuring the EPLCG, you are asked to specify the address within the PLC's memory, where data for this tag will be read from or written to. The format of the address changes, depending on the PLC protocol. If you use Allen-Bradley protocol, only an octal address is required (for example, address 010).

If you use Modicon or Honeywell protocol, the address is composed of an address and a specifier. The specifier is the first part of an address expressed in Modbus format (Honeywell PLCs also use Modbus addressing formats). For example, address 30001 is expressed as address 0001 with a specifier of 3.

The valid specifiers for DHP analog points are 3 and 4. A specifier of 4 indicates that the DHP can read from, and write to, the specified memory location. A specifier of three indicates a read-only address; therefore, analog inputs can use a specifier of either 3 or 4 since both specifiers allow reading of the data. An analog output must always have a specifier of 4.

3.1.4 First Level Processing of Analog I/O Points

3.1.4.1 PLC Range Codes

The PLC Range Code tells the emulated DHP how an analog input or output value is stored in the PLC device. The emulated DHP then uses this information to convert the value to the format that the TPS System uses, which is called B12E. The table below shows where each Range Code is used.

Table 3-1 — Range Code and Where Used

Code	Range	Comments
0	0-999	PLC, PLC2 family
1	0-4095	Used with Modicon PLCs, devices that emulate Modicon, and Honeywell 620 Logic Controller System.
2	0-9999	Used with Allen-Bradley PLCs, or any other PLC that stores its values as numbers in this range; PLC-3,5 families.
3-7	0-9999	Default

B12E is a format that the TPS System uses to store its analog values. The acronym B12E means the following:

- B = Binary Number
- 12 = 12 integer bits (which implies three fractional bits and one sign bit)
- E = Excess 247 (which means that 0% of engineering unit range is 247A/D counts instead of zero).

The data read by the PLC gets into the emulated DHP in the following way. The PLC device reads an input from some process-connected device, such as a transmitter. It then stores the value in either raw A/D counts, or in BCD (as in the case of Allen-Bradley PLC-2s). The emulated DHP then converts the data from the PLC's data storage format to the B12E format and it is used by the TPS System.

Once the value is stored as a B12E number, it can be converted to engineering units. No matter what the data format or the engineering units used, the value can always be expressed in percentage of engineering unit range, as shown in the following chart:

The equation used to determine the values of the B12E number is:

$$\text{B12E} = 3600 (\text{PLC value}/\text{Range}) + 247$$

Table 3-2 — Range Code Usage

From Xmtr	BCD in PLC (RNGCODE=0)	Raw A/D Counts in PLC (RNGCODE=1)	RNGCODE =2	B12E In TPS System	Eng Units (See Note)	% of EU Range
20 mA	999 BCD	4095 Counts	9999 Counts	3847	1000	100%
12 mA	500 BCD	2046 Counts	5000 Counts	2047	500	50%
4 mA	0 BCD	0 Counts	0 Counts	247	0	0%

Note: These values are user defined. Could be 0 - 1000, 0 - 500, -500 - 500, and so on.

3.1.4.2 Alarm Limits and Processing

For further information on this subject, see subsection 3.1.8 in this manual.

3.1.5 Second Level of Analog I/O Processing

3.1.5.1 PV Range Low (PVEULO) and PV Range High (PVEUHI)

During EPLCG configuration, these values are the number of engineering units that correspond to 0% of range and 100% of range. In the above chart, 0% =0 degrees F; 100%=1,000 degrees F. These values should be configured before alarm limits.

3.1.5.2 Decimal Format

Decimal Format specifies the number of decimal places in the value displayed on the screen. The example below shows how the analog value appears for each selection.

D0=XXXX. (no decimal places)
D1=XXX.X (1 decimal place)
D2=XX.XX (2 decimal places)
D3=X.XXX (3 decimal places)

3.1.5.3 Target Value

When configuring the EPLCG, make this entry in engineering units. It is used as a guide to tell operators where they should be operating, as well as for calculating deviation alarms.

3.1.6 PV Source Selection for Analog I/O Points

Parameter PVSOURCE indicates one of three sources for the PV. It can contain Auto, Man, or Sub. These values indicate which source is in effect, as follows:

- Auto—The PV is obtained from its configured source, as indicated by PVSLT SRC and PVSIGNAL. In this case, other points and user programs can't change the PV value.

- **Man**—The PV is a value entered by a Universal Station operator. The operator-entered value is checked against its configured limits and if the PV exceeds one of those limits, the value is clamped at the limit. Either an operator or a user-written program can change the PV source to Man. The operator can't change the Man value while the source is Auto. No alarm checks are made on the Man value; however, alarm checking on the PV continues.
- **Sub**—The PV value is entered by a user-written program. The program-entered value is checked against the configured range limits and if the PV exceeds one of those limits, the value is clamped at the limit. Either an operator or a user-written program can change the PV source to Sub. The Sub value can't be changed while the PV source is Auto. No alarm checks are made on the Sub value.

There are no interlocks to prevent switching from Auto to Man or Sub PV sources at any time. When the PV source is switched from Auto to Man, the initial Man value is made equal to the Auto value, so there is no initial bump in the value. Likewise, when the PV source is switched from Auto to Sub, the initial Sub value is made equal to Auto. A bump in the PV can occur when switching from Man or from Sub to Auto.

The current PV source for each data point is available in data point parameter PVSOURCE for displays or printing.

NOTE

For more information on the parameters mentioned in the following paragraphs, including value types, value ranges, default values, and access levels, refer to the *EPLCG Parameter Reference Dictionary*.

3.1.7 PV Range, PV Clamping Options, and PV Value Status

The following parameters specify PV processing options:

- **PVCLAMP**—PV Clamping Option. Values are NoClamp and Clamp. Access level is Engineer.
- **PVRNGOP**—PV Range Option. Values are None, FullRng, and ClmpZero. Access level is Engineer.
- **PVSOURCE**—The source of the PV. Values are Auto, Man, and Sub. Access level is Supervisor.

These parameters indicate the results of PV processing:

- **PV**—Process Variable. Value range is specified in PVRNGOP.
- **PVSTS**—PV Value Status. Values are Normal, Uncertn, and Bad.
- **PVEXHIFL**—PV Extended High Range Flag. Values are True and False.
- **PVEXLOFL**—PV Extended Low Range Flag. Values are True and False.

The functions of these parameters are as follows:

- PVCLAMP

If PVCLAMP = NoClamp, and the PV is outside the range indicated by PVRNGOP, PVSTS = Bad.

If PVCLAMP = Clamp, and the PV is outside the range indicated by PVRNGOP, PVSTS = Uncertn.

The value in PVCLAMP affects the status indicated by PVSTS.

- PVRNGOP

If PVRNGOP = None, the extended range of the PV value is from -6.9% to 106.9%.

If PVRNGOP = FullRng, the extended range of the PV value is from -2.9% to 102.9%.

If PVRNGOP = ClmpZero, the extended range of the PV value is from 0 to 102.9%.

- PVSOURCE

If PVSOURCE = Auto, the PV is obtained from its configured source, as indicated by PVSLSRC and PVSIGNAL.

If PVSOURCE = Man, the PV value is entered by a Universal Station operator.

If PVSOURCE = Sub, the PV value is entered by a user-written program.

- PVEXHIFL—If the PV is above the high end of the extended range, as specified in PVRNGOP, PVEXHIFL = True. Otherwise it is False.

- PVEXLOFL—If the PV is below the low end of the extended range, as specified in PVRNGOP, PVEXLOFL = True. Otherwise it is False.

- PV—Normally the value in PV represents the magnitude of the process variable. For range checking and clamping, the PV value in percentage-of-range is used, but the PV can be represented in engineering units on the Universal Station displays. The PVRNGOP and PVCLAMP options affect the PV as follows:

If PVCLAMP = NoClamp, and the PV is outside the extended range specified by PVRNGOP, the PV value is NaN (not a number).

If PVCLAMP = Clamp, and the PV is outside the extended range specified by PVRNGOP, the PV value is clamped at the point at which it exceeded the range.

When the PV is clamped, PVSTS = Uncertn.

- PVSTS

PVSTS = Normal when these conditions are both true:

PV is inside the extended range specified by PVRNGOP.

PVSOURCE = Auto.

PVSTS = Uncertain when **either** of these conditions is true:

PVSOURCE contains Man or Sub.

The PV is clamped because it is outside the extended range specified by PVRNGOP and PVCLAMP = Clamp.

PVSTS = Bad when both of these conditions are true:

PVSOURCE = Auto.

PVCLAMP = NoClamp and the PV is outside the extended range specified by PVRNGOP.

If PVSTS = Bad, the value in PV is NaN.

3.1.8 Analog Output Data Point Modes

Analog Output Points can be in manual (MAN) or cascade (CAS) modes only. If you need more information about modes, see subsection 4.4.1 in *System Control Functions*.

3.1.8.1 Analog Output Point Parameter Descriptions

Refer to the *EPLCG Parameter Reference Dictionary*, for the full names, value ranges, default values, value types, and access levels for these parameters.

3.1.9 Point Alarming for Analog Input Points

Alarm checking and reporting for analog inputs is as described under subsection 4.3 in *System Control Functions*.

3.1.10 Alarm Limits (PVLOTP, PVHITP, DEVLOTP, DEVHITP)

These are two types of alarms for analog points: PV and deviation alarms. PV alarms are set in engineering units and are calculated from the actual value of the process variable. For example, if the temperature of a vessel went above 600° F, an alarm could be set.

Deviation alarms result when the process variable deviates from the setpoint by more than the deviation alarm limit. Deviation alarms are set as a percentage of full range that the PV can deviate. For example, assume that the range is 0 to 1,000° F, that the deviation alarm limits are set to +10% and -5%, and that the setpoint equals 500° F. A deviation alarm occurs when the temperature exceeds the setpoint by 10% of range (100° F), or falls below setpoint by 5% of range (50° F); therefore, with the setpoint at 500° F, deviation high alarm occurs at 600° F, and the deviation low alarm occurs at 450° F. If the setpoint is increased to 600° F, the new alarm points are 700° F and 550° F. The number of degrees that the PV could deviate from setpoint did not change. The reference for the alarm calculation did change.

3.1.11 Event-Initiated Processing for Analog Input Points

Event-initiated processing is enabled when parameter EVENTPRC contains Enable. Parameter EIPEVENT defines the types of events that initiate EIP. EIP is described in detail under subsection 4.2 in *System Control Functions*.

3.1.11.1 Analog Composite Point Parameter Descriptions

Refer to the *EPLCG Parameter Reference Dictionary* for the full names, value ranges, default values, value types, and access levels for these parameters.

3.1.12 Analog I/O Point Addressing

User-written programs and standard data acquisition and control functions access the analog point parameters in the EPLCG in the same way that parameters anywhere else in the system are accessed: by specifying the data point name and the parameter; for example, TC101.PV.

3.2 EPLCG DIGITAL I/O DATA POINTS

A digital input data point provides a PV that represents the state of a single discrete value in a PLC. A digital output data point provides a digital state to a location in a PLC. A composite digital I/O point provides one or two inputs and one or two outputs in the same data point.

3.2.1 Digital Input Points

3.2.1.1 Digital Input Point Residences

Digital input data points are EPLCG points whose input slots are in emulated DHPs. For an emulated DHP, the number of digital input points is limited by the number of I/O slots that are configured for digital inputs, at 16 for each slot, for a maximum of 30 slots for each emulated DHP.

In any case, the number of digital input data points can be restricted by limitations in the EPLCG.

A digital input point “reads” the status of a discrete from a PLC. A dual digital input data point “reads” the status of two discrettes from a PLC.

NOTE

When you view the structure of a composite point with dual inputs or outputs on the Box Point Summary or Unit Point Summary display, the second part of the dual point doesn't appear in the table. You should assume that it resides in the next consecutive slot because it must be configured there.

3.2.1.2 Functional Structure of Digital Input Points

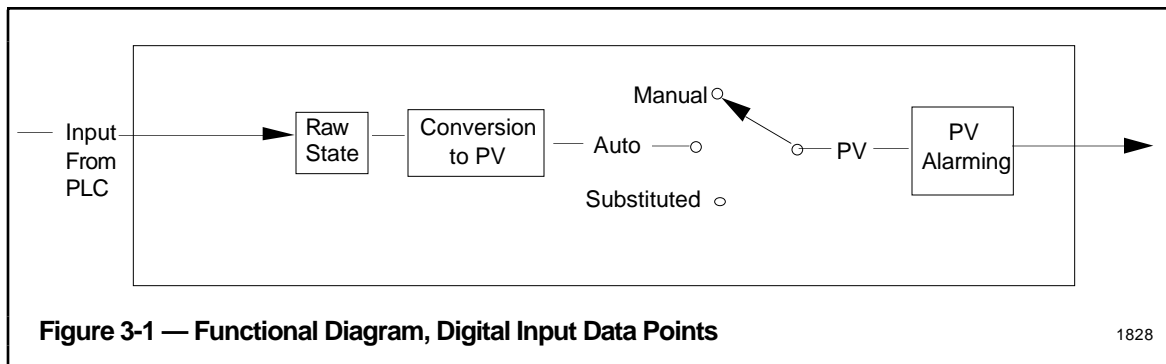

Figure 3-1 — Functional Diagram, Digital Input Data Points

1828

3.2.1.3 Types of Digital Inputs

The TPS system handles change detection, sequence-of-events, and notified-status digital inputs. **EPLCGs provide only notified status digital inputs which record changes of the digital input state.**

3.2.1.4 Functional Description

3.2.1.4.1 Input Detection

Input Voltage Levels, Contact Bounce Filtering—The emulated DHP itself has no input signal conditioning boards, but the programmable controller it interfaces may have them.

DHP Scanning Rate—The EPLCG scans its digital inputs with a free-running scanner that scans as fast as its processor and communication network can.

3.2.1.4.2 Conversion of Raw Contact Inputs to the PV

The PV for a digital input point has two states, such as on/off or open/closed. You configure a descriptor for each of the two PV states in the STATE1 and STATE2 parameters (if you need more information, refer to subsection 3.2.4), and when you do, you relate those states to the states of the raw input wired from the PLC. These descriptors represent the state of each digital input when they appear on US displays.

3.2.1.4.3 PV Source Selection for Notified-Status Inputs

Parameter PVSOURCE indicates the source of the digital input PV. When PVSOURCE contains Auto, the PV is an input from the PLC. When it contains Man, the source is an operator at a US. When it contains Sub, a user-written program or a continuous-control data point provides the PV (see subsection 3.1.7.)

3.2.1.4.4 Digital Input Alarms

Digital point alarms are defined under subsection 3.4.

3.2.1.4.5 Event-Initiated Processing

You can configure digital input points for event-initiated processing (EIP—See subsection 4.2 in *System Control Functions*). EIP occurs for each alarm and each return-to-normal. It also occurs when the PV changes state.

3.2.1.4.6 Digital Input Point Functions

These are digital input functions for EPLCGs:

- Input Acquisition
- PV Conversion
- PV Source Selection
- Alarming: Off Normal, Change of State
- EIP

Note: Inputs are by a free-running scanner.

3.2.1.5 Initialization of Digital Inputs

Digital input data points are initialized when the emulated DHPs are restarted. The emulated DHPs don't initialize in the sense that some hiway-based boxes do. DHPs "initialize" to the state of the inputs first acquired when the emulated DHP goes from the reset state to the processing state. When an emulated DHP is reset, the PV is not available to the EPLCG.

3.2.1.6 Digital Input Point Parameter Descriptions

Refer to the *EPLC Gateway Parameter Reference Dictionary*, for the full names, value ranges, default values, value types, and access levels for these parameters.

3.2.2 EPLCG Digital Output Data Points

A digital output data point writes a single digital state to a location in a PLC. A dual digital output point writes a single digital state to two locations in a PLC.

For the emulated DHP, the number of digital output data points is limited by the number of I/O slots that are configured for digital outputs. There can be up to 8 for each slot and a maximum of 30 slots for a DHP.

There may be some limitation in number of digital output points that the EPLCG can handle, because of the number and mix of boxes on the hiway, and the types of points in the boxes.

The number of momentary (doorbell) digital output points is limited to 500 for the EPLCG.

3.2.2.1 Functional Structure

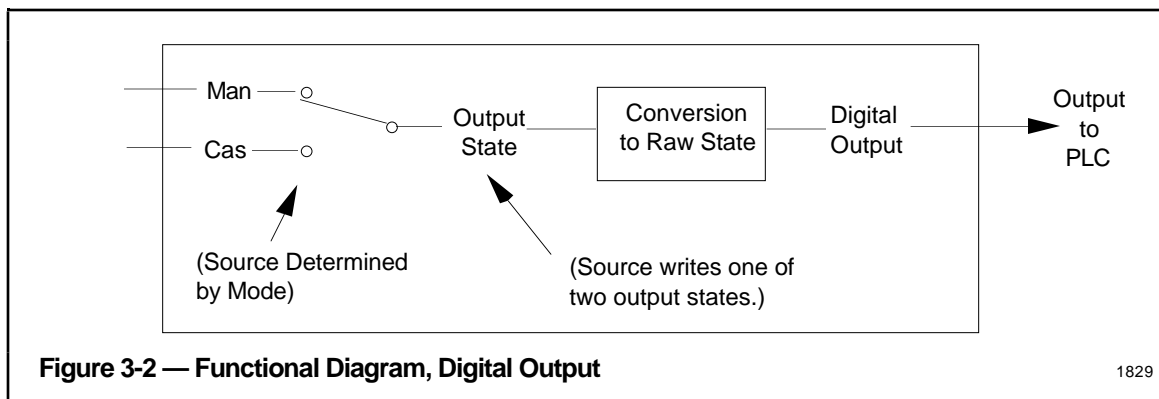

3.2.2.2 Digital Output Functional Description

3.2.2.2.1 Digital Output Behavior

Digital outputs have one of two types of behavior:

Momentary (doorbell)—Outputs can be sent from a Universal Station. A momentary output stays in the specified position as long as the operator or engineer continues to press the appropriate key.

Latched—The output remains in the requested position until a new request is issued.

3.2.2.2.2 Digital Output Modes and Red Tagging

The source of the output request is determined by the mode, which can be:

- CAS—Output state specified by another data point or by a user-written program
- MANual—Output state specified through a Universal Station

When an output is defined as "red tagged," the output does not change despite output requests from a Universal Station or from a user-written program.

3.2.2.2.3 Output State Conversion to Raw Contact Output

The two states of each output are defined by two state descriptors that relate to the two possible states of the stored digital in the PLC. These states could be Open/Closed or Running/Stopped, for example. When you configure a digital output point, you provide the descriptors in the STATE1 and STATE2 parameters, and assign the contact state for each of them.

3.2.2.2.4 Digital Output Point Functions

EPLCG digital output data points can have the following functions: latched or momentary outputs, modes and attributes, red tagging, and output state definition.

3.2.2.3 Digital Output Processing

A request for a digital output change is processed at the next processing pass of the emulated DHP and before the start of a new scan request. The requests are checked against the mode, attribute, and red-tag restrictions by the EPLCG. Once an output state change is affected by the DHP, the DHP does a read-back check to verify the actual output state on the next data scan, and all subsequent data scans change which detect PLC logic.

3.2.2.4 Digital Output Initialization

A digital output point is initialized when it is restarted. During initialization, the EPLCG reads the actual state of the output and set their internal output state to the corresponding state. The emulated DHP reads the state of the coil or defined memory location in the programmable controller. The mode in the emulated DHP is set to the same mode as before the point was initialized.

3.2.2.5 Digital Output Parameter Descriptions

Refer to the *EPLC Gateway Parameter Reference Dictionary* for the full names, value ranges, default values, value types, and access levels for each parameter.

3.2.3 EPLCG Digital I/O Composite Data Points

A digital I/O composite data point consists of one or two digital inputs and one or two digital outputs with the same tag name. The input slot (and subslots) and the output slot (and subslots) must be in the same emulated DHP. Typically, the inputs show the direct or indirect result of the digital output, on the PLC that the output(s) is wired to.

NOTE

When you view the structure of a composite point with dual inputs or outputs on the Box Point Summary or Unit Point Summary display, the second part of the dual point doesn't appear in the table. You should assume that it resides in the next consecutive slot because it must be configured there.

3.2.3.1 Functional Structure

See Figure 3-3.

3.2.3.2 Functional Description

3.2.3.2.1 Digital I/O Composite Data Point—I/O Combinations

Each digital I/O composite data point can be configured for one or two inputs (NMBRINPT) and one or two outputs (NMBROUT).

The functions for the inputs and outputs are essentially the same as for the individual inputs (3.2) and outputs (3.3).

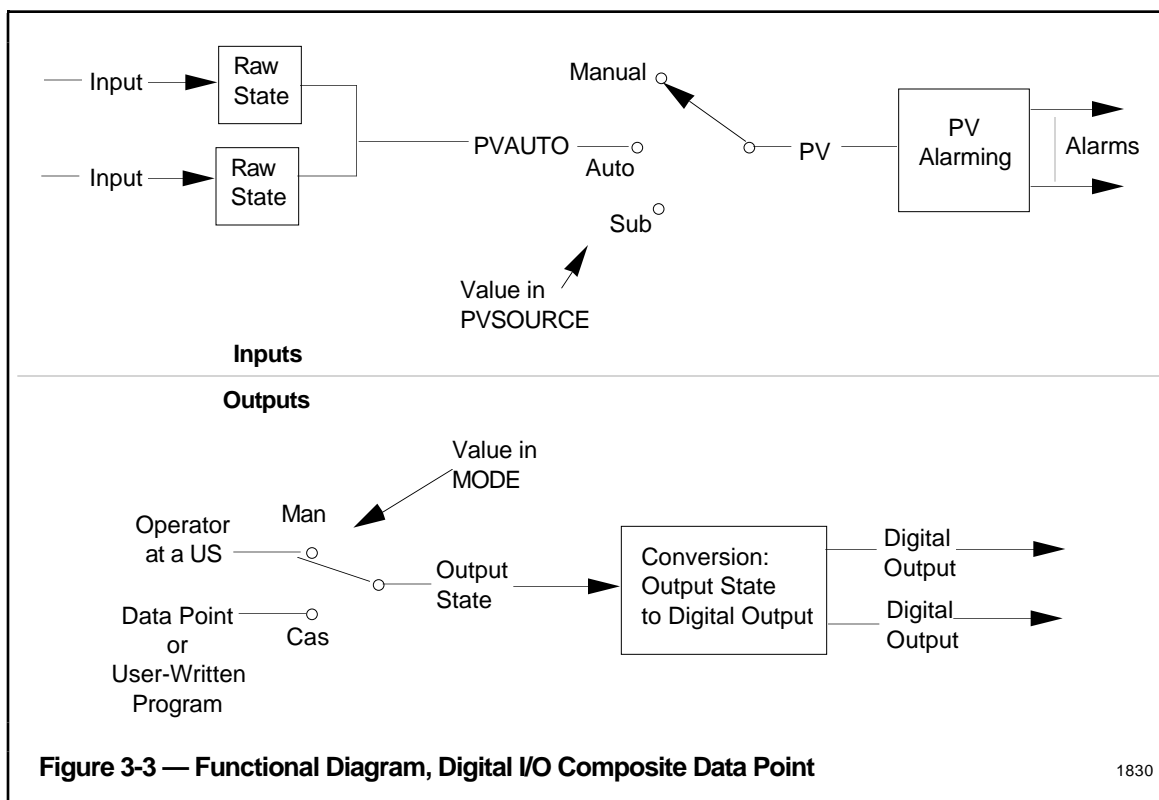

3.2.3.2.2 Input Detection for Digital I/O Composite Points

Input detection is the same as described under subsection 3.2.1.4.1 except that only notified-status inputs are accepted by digital I/O composite data points.

3.2.3.2.3 *Conversion of Input(s) to PV(s)*

The PV(s) represent the current state(s) of the input signal. A single input can generate two PVs. Dual inputs can generate four PV states. The PV for a digital input point has two states like on/off or open/closed. You configure a descriptor for each of the two PV states in the STATE1 and STATE2 parameters (see subsection 3.2.4), and when you do, you relate those states to the states of the raw digital acquired from the PLC. These descriptors represent the state of each digital input when they appear on US displays. If dual inputs are used, the descriptors for the remaining two states default to Bad and InBetween.

3.2.3.2.4 *PV Source Selection for Digital Composite I/O Points*

Parameter PVSOURCE indicates the source of the digital input PV. When PVSOURCE contains Auto the PV is derived from the PLC. When it contains Man, the source is an operator at a US. When it contains Sub, a user-written program or a continuous-control data point provides the PV (see subsection 3.1.7.)

3.2.3.2.5 *Alarming*

Digital point alarms are defined under subsection 3.2.4.

3.2.3.2.6 *Event-Initiated Processing for Digital I/O Composite Points*

You can configure digital I/O composite points for event-initiated processing. EIP occurs when an alarm is detected or on a return-to-normal. See subsection 4.2 in System Control Functions.

3.2.3.2.7 *Modes/Attributes/Red Tagging*

The source of an output request is indicated by the value in the MODE parameter, which can be:

- CAS—Output state specified by another data point or by a user-written program
- MANual—Output state specified through a Universal Station

When an output is defined as "red tagged," the output does not change, despite output requests from a Universal Station or from a user-written program.

The attributes determine if an operator (Oper) or a user-written program (Prog) can change the mode and the PV when in Manual mode.

3.2.3.2.8 *Output State Conversion to Raw Contact Output*

The output to the PLC can have two states. These correspond to the two possible states of the memory location of the PLC, one/zero or true/false. You configure a descriptor for each of the two states in parameters STATE1 and STATE2. The descriptors relate the state of the output to the state at the output terminals ("raw" outputs).

3.2.3.2.9 Digital I/O Composite Point Functions in DHPs

The following are digital composite point functions in EPLCGs:

- Input Acquisition
- PV Conversion
- PV Source Selection
- Alarms (see subsection 3.2.4)
- EIP, Output Behavior: Latched, Pulsed; Modes/Attributes
- Red Tagging
- Output State Conversion

Note: Inputs are scanned by a free-running scanner.

3.2.3.3 Processing of Digital I/O Composite Points

Outputs are processed as described under subsection 3.2.2.4.

3.2.3.4 Initialization

Initialization is as described under subsection 3.2.1.5 and subsection 3.2.2.5.

3.2.3.5 Digital I/O Composite Parameter Descriptions

Refer to the *EPLC Gateway Parameter Reference Dictionary* for the full names, value ranges, default values, value types, and access levels for each parameter.

3.2.4 DIGITAL ALARMS

The types of digital alarms are:

- **Change-of-state alarms**—The alarm is detected when the state of a digital input point changes in either direction. This alarm is cleared from the Alarm Summary Display when the alarm is acknowledged.
- **State alarms**—The alarm is generated when the input point is in the state contained in the DIGALFMT parameter. The states for this alarm are State 1, State 2, Input 1, Input 2, Either, and Both. This alarm remains on the Alarm Summary Display until the point is no longer in the alarm state.
- **Command disagree alarms**—These alarms apply to only digital composite points. The alarm is generated when the point has been commanded output to go to a state, and after a user-defined time, the input state does not agree with the commanded state.

For state, change-of-state, and command disagree alarms, the alarm descriptor that appears on the Alarm Summary Display is the actual state of the digital PV, which can be the string value (self-defined enumeration) in any of these parameters: STATE1, STATE2, ZZTEXT, or the complement of ZZTEXT. If DIGALFMT contains Either and Both boxes for the point on the Group or Detail Display are lit, the state shown on the Alarm Summary Display is that of the first box lit.

You configure the types of alarms for these points in parameter DIGALFMT. Details of the alarm options, alarm conditions, and the effect on the Group and Detail displays for these points are provided under the listing for DIGALFMT in the *EPLC Gateway Parameter Reference Dictionary*. The alarm formats that can be configured for each type of digital point are listed on the configuration forms and appear on the Data Entity Builder's parameter entry displays (PEDs). The formats for EPLCG (DHP) digital points are:

- State1—State 1 alarm
- State2—State 2 alarm
- Chngofst—Change-of-state alarm
- Cmmdis—Command disagree alarm

The following parameters are also related to digital alarms:

- INPDIR—Input direction
- OUTIND—Output indication
- ZZTEXT—State 00 text (neither box lit)
- NCMPTXT1 and NCMPTXT2—Noncomplementary inputs text

3.2.4.1 Summary of Digital States and Alarms

The following chart shows which digital alarm types apply to single input and dual input points. The command disagree alarm applies only to digital I/O points.

Applicable Alarm Type	Single Input	Dual Input
Noalm (no alarm)	Yes	Yes
State1	Yes	
State2	Yes	
Chngofst (change of state)	Yes	Yes
Cmmdis (command disagree)*	Yes	Yes

*Only with a composite output point.

For single digital inputs

State Presentation					State Description on Alarm Summary Display			
Input State (PV)	State Parameter	State Text	Boxes Lit	LCN Ordinal	State Alarm		Command Disagree	
					State 1	State 2	State 1	State 2
0 1	STATE1		Lower	0	STATE1	n/a	n/a	STATE1
1 0	STATE2		Upper	1	n/a	STATE2	STATE2	n/a

Reverse Indication (points to 0 1)
 Direct Indication (points to 1 0)

For dual digital inputs

State Presentation					State Description on Alarm Summary Display					
Input State (PV)	State Parameter	State Text	Boxes Lit	LCN Ordinal	State Alarm				Commnd Disagree	
					Input 1	Input 2	Either	Both	State 1	State 2
00 11	ZZTEXT		None	0	n/a	n/a	n/a	n/a	ZZTEXT	ZZTEXT
01 10	STATE1		Lower	1	n/a	ST1	ST1	n/a	n/a	STATE1
10 01	STATE2		Upper	2	ST2	n/a	ST2	n/a		
11 00	CZZT		Both	3	ST2	ST1	STx	CZZT	CZZT	CZZT

Reverse Indication (points to 00 11)
 Direct Indication (points to 11 00)

For single digital outputs

State Presentation					What Activates Output with Group or Detail Display
Output State (OP)	State Parameter	State Text	Boxes Lit	LCN Ordinal	
0 1	STATE1		Lower	0	Down Arrow
1 0	STATE2		Upper	1	Up Arrow

Reverse Indication (points to 0 1)
 Direct Indication (points to 1 0)

For dual digital outputs

State Presentation					What Activates Output with Group or Detail Display
Output State (OP)	State Parameter	State Text	Boxes Lit	LCN Ordinal	
00 11	"NONE"		None	0	(Not Possible)
01 10	STATE1		Lower	1	Down Arrow
10 01	STATE2		Upper	2	Up Arrow
11 00	"BOTH"		Both	3	(Not Possible)

Reverse Indication (points to 00 11)
 Direct Indication (points to 11 00)

11761

In this chart, dual input states are given in input 1, input 2 order—input 1 is the subplot specified and input 2 is that subplot plus one. These abbreviations are used for parameter names and values:

ST1 and ST2 mean STATE1 and STATE2. ZZT means ZZTEXT. CZZT means the complement of the value in ZZTEXT. The integers in the "LCN Ordinals" column are values that can be accessed by upper-level processors through CGs to determine the input states of digital points.

3.3 EPLCG COUNTER DATA POINTS

Counter data points acquire or accumulate real numbers from a digital counter in a PLC. The PLC inputs are typically accumulated values from instruments like pulse-type flow meters, speedometers, or event counters, but can be any integer stored by the PLC in the defined location.

EPLCG counter data points use counter slots in emulated DHPs. Each DHP slot can have eight counters.

An EPLCG counter point can be used to write a value to a PLC location. The PLC can overwrite this location if it is truly a counter, and it can treat the location as a supervisory control input.

3.3.1 Functional Structure, EPLCG Counter Point

The structure of a EPLCG counter is shown on Figure 3-4.

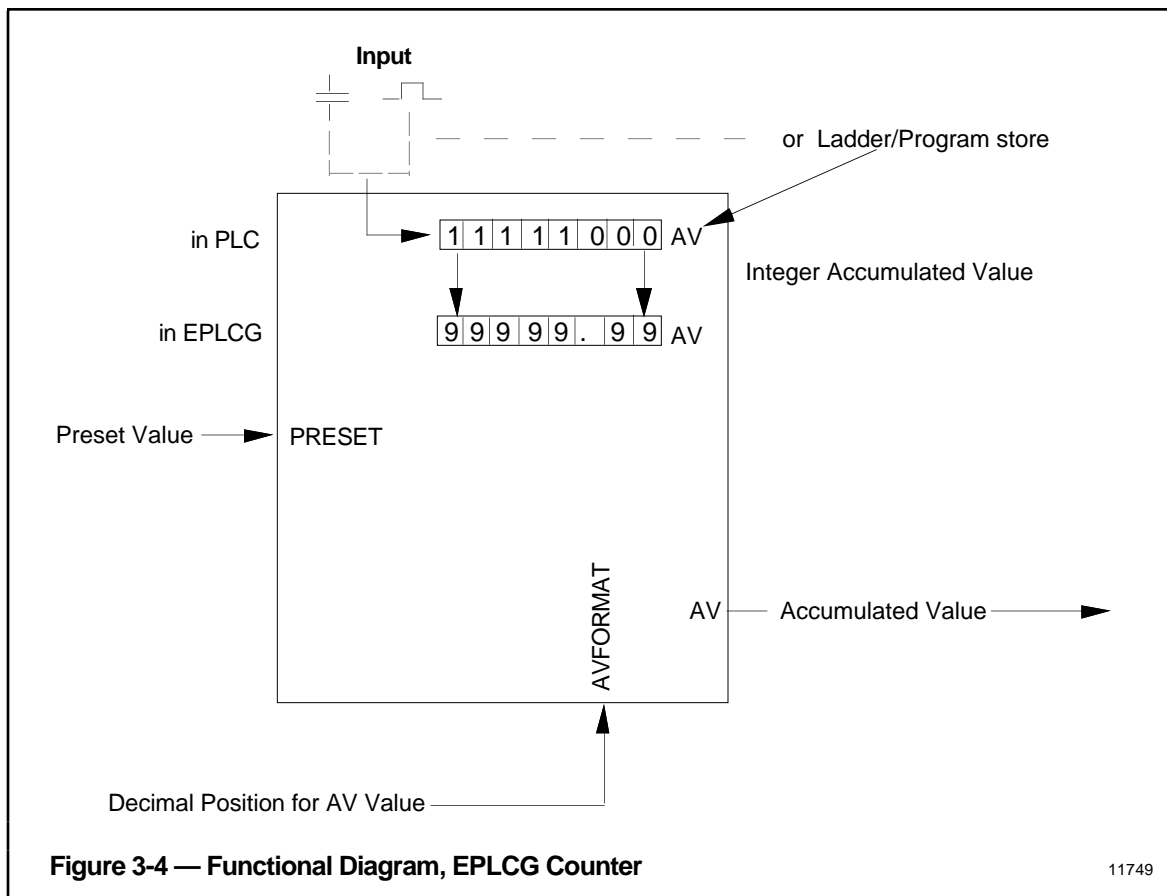

3.3.2 Counter Functions

The counter provides the current count value in the PV parameter, and an accumulated value (based in engineering units) of the AV parameter. The increments of the accumulated value is established when the point is built, and may be changed at a Universal Station by using an engineer's key. An operator can preset the AV value by entering a value in PRESET.

3.3.3 EPLCG Counter Parameters

For information on the functions, value types, ranges, and access levels of these parameters, refer to the *EPLC Gateway Parameter Reference Dictionary*, and to the *EPLC Gateway Configuration Form Instructions*.

3.3.4 EPLCG Counter Processing

Emulated DHP counters are updated by the free-running scan.

3.4 EPLCG HIWAY AND BOX/SLOT DATA POINTS

EPLCG hiway data points contain parameters that define the EPLCG's emulated Data Hiway to the system. EPLCG box data points contain parameters that define the emulated DHPs ("boxes" on the emulated hiway) and assign a box number or hiway address to each DHP. One box point is configured for each of the up to eight emulated DHPs. Both hiway and box points are built with the Data Entity Builder. To access the Parameter Entry Displays for these points, on the Engineering Main Menu, select HIWAY GATEWAY, then on the next menu select HIWAY CONFIG or BOX/SLOT CONFIG.

3.4.1 Hiway Point Parameters

For information on the functions, value types, ranges, and access levels of these parameters, refer to the *EPLC Gateway Parameter Reference Dictionary*, and to the *EPLC Gateway Configuration Form Instructions*.

3.4.2 Box/Slot Data Point Processing

Box data points are not scheduled for processing, nor processed at regular intervals like other data points are. Their parameters are updated when necessary by the EPLCG and the boxes. Hiway data points and box data points must be configured for EPLCGs. Even though the emulated DHPs in an EPLCG are not physical boxes on a physical Data Hiway, hiway and box data points must still be configured for them.

Performance and communication information is maintained by the EPLCG's emulated DHPs. These statistics may be obtained by using SMCC. For more information, refer to *EPLC Gateway Planning, Installation, and Service*.

3.4.3 Box/Slot Data Point Parameters

For information on the functions, value types, ranges, and access levels of these parameters, refer to the *EPLC Gateway Parameter Reference Dictionary*, and to the *EPLC Gateway Configuration Form Instructions*.

3.4.4 Box/Slot Point Names

Box Points have reserved-entity names, which are automatically established by the Data Entity Builder as you build the points. Users and user programs can refer to box point parameters through the reserved-entity names. For example:

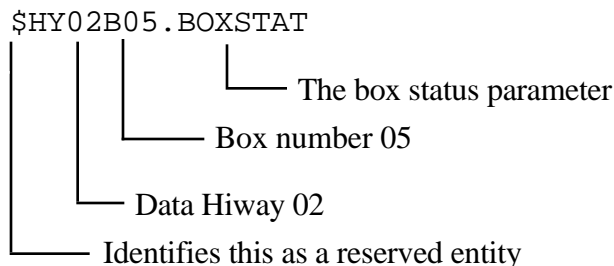

11766

3.5 SPECIAL POINT RELATED FUNCTIONS

3.5.1 Associated Display

With Release 510 and later software, an Associated Display can be configured for each HG point at build time by entering the name of a custom-built schematic in the ASSOCDSP parameter. At operating time, the operator can call up that associated custom schematic from a point Detail Display or Group Display.

The ASSOCDSP parameter can be changed from the configuration page of the Detail Display (for points that have a configuration page).

3.5.2 Auxiliary Units

Alarmable EPLC points in Release 520 and later software have an Auxiliary Unit (`$AUXUNIT`) parameter. If this parameter is set to null (- -), alarms and messages on that point go to the primary unit. If a valid Unit ID is specified, alarms and messages from that point go to the Auxiliary Unit.

`$AUXUNIT` can be configured at build time or, with the proper keylevel, it can be initially assigned or changed by schematics, CL programs, the DEB alter parameters function, or from the configuration page of the Point Detail display. The keylevel necessary to change `$AUXUNIT` is configurable in the System Wide Values section of the Network Configuration File.

Alarms from a point where `$AUXUNIT` has been configured are accepted only by Universal Stations having an Area Database in which both the Primary Unit and the Auxiliary Unit are configured.

If an `$AUXUNIT` assignment is changed and there are outstanding alarms on the old unit, alarms are deleted from the old unit and added to the new unit.

Index

Topic	Section Heading
Alarms	
Analog Points	3.1.9
Critical	2.7.3
Critical Status	2.7.3
Digital	3.2.4
Limits	3.1.10
Allen-Bradley PLCs	2.8.2.2
Analog Input Points	2.7.5
Analog I/O Data Points, EPLCG	3.1
Point Addressing	3.1.12
First Level Processing	3.1.4
Second Level Processing	3.1.7
Analog Output Data Point Modes	3.1.8
Associated Display	3.5.1
Auxiliary Units	3.5.2
B12E (TPS System format)	3.1.4.1
Backup, EPLCG	2.4
Box (DHP) Control States	2.3.9
Box/Slot Data Point	3.4
Names	3.4.4
Parameters	3.4.3
Processing	3.4.2
Relating to PLCs	2.6.1
Boxes (Emulated DHPs)	
Functions Related to	2.8.1
Capacity, Data Point, EPLCG	2.7
Clamping	2.8.1.5
Options, PV, Analog Points	3.1.7
Composite Data Points	
Composite Points in One Box	2.7.2
EPLCG Digital I/O	3.2.3
Contact-Cutout Secondary Points	2.7.7
Control Time-out Function	2.8.1.2
Counter Data Points	3.3
Functional Structure	3.3.1
Processing	3.3.4
Critical Alarm Status	2.7.3
DHP (Emulated)	
Control States	2.3.9
Status	2.3
Startups	2.8.1.1
Digital Data Points	
Alarms	3.2.4
Composite Data Points	3.2.3
Digital Input Points	3.2.1
Digital Output Data Points	3.2.2
"Doorbell" Points	2.7.4
Momentary Points	2.7.4
Summary of States and Alarms	3.2.4.1
"Doorbell" Digital Points	2.7.4
Emergency Alarms	2.7.3
Entities, Reserved	2.6.2

Index

Topic	Section Heading
Errors	
Avoiding Errors	2.5.1
Error Codes	2.5
Errors on Input and Output Requests to PLCs	2.5.2
Event Initiated Processing	
Analog Points	3.1.9
Points with EIP	2.7.6
Fail-COM Box Status	2.3.5
Fail-HDW Box Status	2.3.6
Failover Scenario	2.4.1
Fifty Points with Critical Alarm Status	2.7.3
Format	
Decimal (Analog values)	3.1.5.2
TPS System (B12E)	3.1.4.1
Functions	
EPLCG, Special	2.8
Related to DHPs	2.8.1
Special, Related to PLCs	2.8.2
Time-out, Control	2.8.1.2
General Parameter Access	2.8.1.3
Handling	
Reverse-Acting Transmitter	2.8.1.6
Hiway Gateways	
Hiway Point Parameters	3.4.1
Hiway States	2.2
Idle-SF, Idle-PF	2.3.4
Input Points	
Analog	2.7.5
Digital	3.2.1
Keep-Alive Addressing	2.8.2.3
Modes and Attributes	
Modes, Data Point, Analog Output	3.1.8
Modicon PLCs	2.8.2.1
Momentary ("Doorbell") Digital Points	2.7.4
Multifunction Controller	
Names, Box Points	3.4.4
Parameters, EPLCG	
Analog Composite	3.1.9.1
Analog Input	3.1.3.1
Analog Output	3.1.8.1
Box/Slot	3.4.3
Counter	3.3.3
Digital Composite	3.2.3.7
Digital Input	3.2.1.6
Digital Output	3.2.2.5
Hiway Point	3.4.1
EPLCG Parameters, Configuration	2.5, 2.6.3

Index

Topic	Section Heading
PLCs	
Allen-Bradley	2.8.2.2
Modicon	2.8.2.1
PLC Addressing	
Relating EPLCGs to	2.6.1
EPLCG Counter Point	
Functional Structure	3.3.1
Parameters	3.3.3
Processing	3.3.4
Points	
Analog Input	2.7.5
Analog I/O	3.1
Contact Cutout Secondary	2.7.7
Event-Initiated Processing, Points with	2.7.6
Composite Points in One Box	2.7.2
Fifty Points with Critical Alarm Status	2.7.3
Momentary "Doorbell" Digital Points	2.7.4
Point Alarming, Analog Points	3.1.9
Point Capacity, EPLCG	2.7.1
Point Processing, Analog I/O	3.1.12
Point Types	
Analog	3.1.1
Digital	3.2.1.3
Point Types,	
Process Variable	see PV
Process-Connected Subsystems	
Special Functions Related to	2.8.2
Processing	
Analog I/O Point	3.1.11
Analog Points, Order of	3.1.3
Counter	3.3.4
Event-Initiated, Analog Points	3.1.9
First Level of Analog I/O Points	3.1.4
Second Level of Analog I/O Points	3.1.5
PV	
Clamping Options, Analog Points	3.1.7
Range and Clamping, Analog Points	3.1.7
Range, Analog Points	3.1.7
Source Selection	2.8.1.4
Source Selection, Analog Points	3.1.7
Value Status	2.8.1.7
PVEUHI, PVEULO	3.1.5.1
Range, PV, Analog Points	3.1.7
Range Codes, PLC	3.1.4.1
References	1.1
Reset Box Status	2.3.7
Reverse-Acting Transmitter Handling	2.8.1.6
RNGCODE0,1,2	3.1.4.1
Run State	2.3.1
Run-PF	2.3.3
Run-SF	2.3.2

Index

Topic	Section Heading
Scenario, EPLCG Failover	2.4.1
Secondary Points, Contact-Cutout	2.7.7
Selection, PV Source, Analog Points	3.1.7
Selection, PV-Source	2.7.1.4
Software Upgrades	2.8.3
Source Selection, PV, Analog Points	3.1.7
Special EPLCG Functions	2.7
Startups, DHP	2.8.1.1
States	
Box (DHP) Control	2.3.9
Hiway	2.2
Run	2.3.1
Status	
Emulated DHP	2.3
PV Value	2.8.1.7
Target Value	3.1.5.3
Total EPLCG Point Capacity	2.7.1
Transmitter Handling, Reverse-Acting	2.8.1.6
Uncertain Box (DHP) Status	2.3.8
Value Status, PV	2.8.1.7

READER COMMENTS

Honeywell IAC Automation College welcomes your comments and suggestions to improve future editions of this and other publications.

You can communicate your thoughts to us by fax, mail, or toll-free telephone call. We would like to acknowledge your comments; please include your complete name and address.

BY FAX: Use this form; and fax to us at (602) 313-4108

BY TELEPHONE: In the U.S.A. use our toll-free number 1*800-822-7673 (available in the 48 contiguous states except Arizona; in Arizona dial 1-602-313-5558).

BY MAIL: Use this form; detach, fold, tape closed, and mail to us.

Title of Publication: **EPLCG Control Functions** Issue Date: **7/96**
Publication Number: **EP09-500**
Writer: **Bill Damours**

COMMENTS: _____

RECOMMENDATIONS: _____

NAME _____ DATE _____
TITLE _____
COMPANY _____
ADDRESS _____
CITY _____ STATE _____ ZIP _____
TELEPHONE _____ FAX _____

Honeywell

Industrial Automation and Control
Honeywell Inc.
16404 North Black Canyon Highway
Phoenix, Arizona 85023-3033

Helping You Control Your World