

Enhanced Programmable Logic Controller Gateway Implementation Guidelines

EP12-500

**Implementation
EPLC Gateway**

***Enhanced Programmable
Logic Controller Gateway
Implementation Guidelines***

**EP12-500
9/95**

Copyright, Trademarks, and Notices

Printed in U.S.A. – © Copyright 1995 by Honeywell Inc.

Revision 01 – September 15, 1995

While this information is presented in good faith and believed to be accurate, Honeywell disclaims the implied warranties of merchantability and fitness for a particular purpose and makes no express warranties except as may be stated in its written agreement with and for its customer.

In no event is Honeywell liable to anyone for any indirect, special or consequential damages. The information and specifications in this document are subject to change without notice.

Trademark Acknowledgements

Other brand or product names are trademarks of their respective owners.

About This Publication

This publication summarizes the Enhanced Programmable Logic Controller Gateway (EPLCG) implementation process, guides you to procedures and references you need to implement EPLCGs, defines the hiway and box/slot entities you must build for each EPLCG, and describes EPLCG operation considerations in implementing and using EPLCGs.

This publication supports Release 500.

Table of Contents

1	INTRODUCTION
1.1	Summary of EPLCG Implementation Tasks
1.2	References
1.2.1	References for Engineering Activities
1.2.2	References for Hardware Implementation
1.3	EPLCG Implementation Dependencies
2	HIWAY AND BOX/SLOT CONFIGURATION
2.1	Purpose of the Hiway and Box/Slot Entities
2.2	Hiway and Box/Slot Entities to be Built
2.2.1	Hiway Entities
2.2.2	Box/Slot Entities
2.3	Order for Hiway and Box/Slot Entity Building
2.4	Hiway Configuration
2.4.1	Hiway Number
2.4.2	Hiway Traffic Director Functions
2.4.3	Sequence-of-Events Synchronization
2.5	Box/Slot Configuration
2.5.1	EPLCG Data Hiway Addresses
2.5.2	Emulated DHP Hiway Address Assignments
2.5.3	EPLCG and DHP Box Assignment
2.5.4	Event Processing
2.5.5	Change Detection
3	EPLCG OPERATIONAL CONSIDERATIONS
3.1	The EPLCG Subsystem
3.2	Loading, Saving, and Restoring of EPLCG Data
3.2.1	EPLCG Initial Startup or Restart
3.2.2	Initial Startup of a EPLCG
3.2.3	Saving of EPLCG and DHP Data
3.2.4	Restoring EPLCG and DHP Data
3.2.5	Recovering from Checkpointing and Loading Errors
3.3	EPLCG Functions
3.3.1	Redundant Gateways
3.3.2	Redundant Communications
3.3.3	Reporting by Exception in Allen-Bradley PLCs
3.3.4	MODBUS Digital Output Scan Suppression
4	EPLCG PERFORMANCE CONSIDERATIONS
4.1	Factors Limiting Performance
4.2	Effects of Database Composition
4.3	Adjusting a EPLCG for Performance
I	INDEX

INTRODUCTION

Section 1

This section summarizes the Enhanced Programmable Logic Controller Gateway implementation tasks, lists publications that you will refer to in order to implement EPLCGs, and describes implementation dependencies.

1.1 SUMMARY OF EPLCG IMPLEMENTATION TASKS

While most of the the information in this publication relates to Enhanced Programmable Logic Controller Gateway (EPLCG) functions, EPLCG data points, and EPLCG operating considerations, other implementation activities must also be completed to make the EPLCG functional. The Engineering Personality activities listed below may be affected by the implementation of a EPLCG or must be used to implement a EPLCG.

See subsection 1.2 for references to instructions for each of the activities listed below.

Activities named in THIS TYPEFACE are activated by targets on the Engineering Personality Main Menu.

- **UNIT NAMES**—The process units defined for each EPLCG data point are established in this activity.
- **AREA NAMES**—The area name and descriptor for any units with EPLCG points that are assigned to an area are established in this activity.
- **LCN NODES**—Identifies and defines the nodes on the Local Control Network. In the case of EPLCGs, this activity defines the node numbers for the EPLCGs and the process network number for the EPLCGs' emulated Data Hiways. Note that because the EPLCG is supported by the Hiway Gateway software, you configure EPLCGs as if they were HGs.
- **VOLUME CONFIGURATION**—The EPLCG (HG) checkpoint volume(s), &7np is established in this activity. Volume &7np must have adequate storage space to accommodate the EPLCG checkpoint data, including the data for its emulated DHPs (boxes).
- **APPLICATION MODULE**—Any AM points that are members of a control strategy that includes EPLCG points are built in this activity. Connections to the EPLCG points are defined in `tagname.parameter` form.
- **HIWAY GATEWAY**—The Hiway point which defines the EPLCG's emulated Data Hiway and the Box/Slot points that define the functions and content of the emulated DHPs are built in this activity. Also, the EPLCG data points are built in this activity.
- **PICTURE EDITOR, FREE FORMAT LOGS, BUTTON CONFIGURATION**—Any of pictures, logs, and buttons built by these activities can access EPLCG points, once the points are built and loaded.

- **HM HISTORY GROUPS**—EPLCG data point values for which continuous history is to be collected are defined in this activity, by assigning them to specific HM history groups.
- **AREA DATA BASE**—This activity defines how and where data for data points, including EPLCG data points, are used and displayed in a given process area. The area database is the database loaded into a Universal Station, so that the database defines the process area monitored and controlled through the US.
- **Control Language (CL)**—The EPLCG does not have a CL program feature, but CL/AM programs can read from and write to EPLCG data points.
- **Ladder Logic Programming**—The make and model of the PLC(s) connected to the EPLCG can widely differ, so the Honeywell IAC publications do not provide information for ladder logic programming. Consult the manuals provided by the PLC vendor(s).

1.2 REFERENCES

1.2.1 References for Engineering Activities

- **UNIT NAMES and AREA NAMES**
 - Network Form Instructions in the Implementation/Startup and Reconfiguration - 1 binder.*
 - Network Data Entry in the Implementation/Startup and Reconfiguration - 1 binder.*
- **VOLUME CONFIGURATION**—Section 7 of the *Engineer's Reference Manual* in the *Implementation/Startup and Reconfiguration - 2 binder*. For the EPLCG checkpoint volume(s), follow the instructions for HG checkpoint volumes.
- **APPLICATION MODULE**
 - Application Module Control Functions in the Implementation/AM - 1 binder.*
 - Application Module Algorithm Engineering Data in the Implementation/AM - 1 binder.*
 - Application Module Parameter Reference Dictionary in the Implementation/AM - 1 binder.*
 - Data Entity Builder Manual in the Implementation/Engineering Operations - 1 binder.*
- **HIWAY GATEWAY (EPLCG)**
 - System Control Functions in the Implementation/Startup & Reconfiguration - 2 binder.*

Enhanced Programmable Logic Controller Gateway Control Functions in the *Implementation/EPLC Gateway* binder.

Enhanced Programmable Logic Controller Gateway Parameter Reference Dictionary in the *Implementation/EPLC Gateway* binder.

Data Entity Builder Manual in the *Implementation/Engineering Operations - 1* binder.

- PICTURE EDITOR, FREE FORMAT LOGS, BUTTON CONFIGURATION

Instructions for these activities are in the *Implementation/Engineering Operations - 2* binder.

- HM HISTORY GROUPS

HM History Group Form Instructions in the *Implementation/Engineering Operations - 1* binder.

Data Entity Builder Manual in the *Implementation/Engineering Operations - 1* binder.

- AREA DATA BASE

Area Form Instructions in the *Implementation/Engineering Operations - 1* binder.

Data Entity Builder Manual in the *Implementation/Engineering Operations - 1* binder.

1.2.2 References for Hardware Implementation

1.2.2.1 Site Planning

LCN Site Planning manual in the *System Site Planning* binder.

Enhanced Programmable Logic Controller Gateway Planning, Installation, and Service in the *Implementation/EPLC Gateway* binder.

1.2.2.2 Installation and Checkout

Enhanced Programmable Logic Controller Gateway Planning, Installation, and Service in the *Implementation/EPLC Gateway* binder.

1.2.2.3 Service

Five/Ten-Slot Module Service in the *LCN Service-1* binder (Enhanced Programmable Logic Controller Gateway).

Enhanced Programmable Logic Controller Gateway Planning, Installation, and Service in the *Implementation/EPLC Gateway* binder.

1.3 EPLCG IMPLEMENTATION DEPENDENCIES

Figure 1-1 shows which EPLCG implementation tasks depend on information entered in other tasks. This figure does not necessarily dictate the order in which the tasks must be completed, but it does show all dependencies that must be satisfied before the EPLCG can be fully operational.

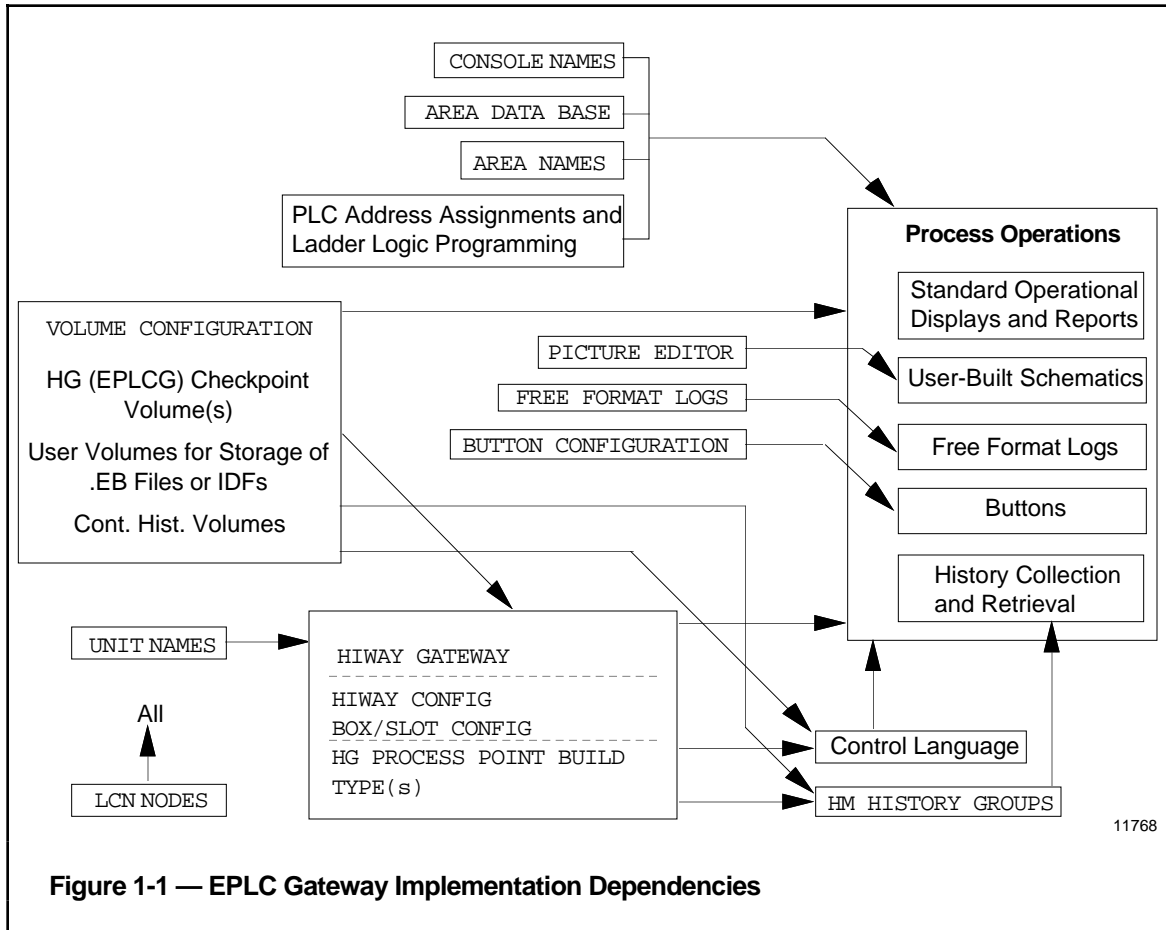

HIWAY AND BOX/SLOT CONFIGURATION Section 2

This section provides guidelines for building hiway and box/slot configuration entities for each EPLC Gateway.

2.1 PURPOSE OF THE HIWAY AND BOX/SLOT ENTITIES

Each hiway entity (point) defines for the LCN system, the EPLC Gateway (EPLCG), and the emulated Data Hiway. Each box/slot entity defines for the LCN system and the EPLCG, one of the emulated Data Hiway Ports (DHPs) in the EPLCG and each slot in each DHP.

2.2 HIWAY AND BOX/SLOT ENTITIES TO BE BUILT

The EPLCGs in an EPLCG pair always use hiway addresses 02 and 03 on the emulated Data Hiway. The emulated DHPs in each EPLCG or EPLCG pair always use hiway addresses 08 through 15. For more information about this addressing scheme, refer to subsection 2.5 in *EPLC Gateway Control Functions* in the *LCN Implementation/EPLC Gateway* binder.

2.2.1 Hiway Entities

You must build a hiway entity for each EPLC Gateway. Each LCN can have up to 20 process networks. Each Data Hiway or Universal Control Network is one process network, so the sum of EPLCG Hiway Entities, Hiway entities for Data Hiways connected to HGs, and UCNs cannot exceed 20. Please note the emulated hiway counts as a process network, even though is not a physical hiway.

Hiway entities are reserved entities; that is, they are entities whose names are reserved for use by the system and begins with a dollar sign. The names are in this form:

\$HIWAYnn

where nn is the hiway number (01 through 20).

2.2.2 Box/Slot Entities

You must build one box/slot entity for each emulated DHP for which you need to build data points. Each EPLCG can have up to eight DHPs.

Like hiway entities, box/slot entities are reserved entities; that is, they are entities whose names begin with a dollar sign, and are reserved for use by the system. The names are in this form:

\$HYnnBxx

where nn is the hiway number (01 through 20) and xx is the hiway box number [2 and 3 for the EPLCG partners (primary and backup) and 8 through 15 for the DHPs].

2.3 ORDER FOR HIWAY AND BOX/SLOT ENTITY BUILDING

The order in which the Hiway and Box/Slot Configuration activities are accomplished is important. To build them, select HIWAY GATEWAY on the Engineering Main Menu, which calls up the HG Build Type Configuration Menu. Then select HIWAY CONFIG to build the hiway entity and BOX/SLOT CONFIG to build the box/slot entities.

Do these activities in this order:

1. HIWAY CONFIG
2. BOX/SLOT CONFIG for this EPLCG pair (HG 2 and 3).
3. BOX/SLOT CONFIG for each DHP in use in this EPLCG pair (8 through 15).

NOTE

When performing this initial load of a DHP's Box/Slot Configuration, an "A80" Addressing Error will occur. To clear the error, select `Init Addr` from the Hiway Command menu under the Hiway Status Display. Load the DHP Box/Slot Configuration a second time. This time there should be no errors.

The reserved entities that are defined by these tasks must be loaded in the order listed above. This means you must use individual Load commands to load the entities separately in this order, or you must use a Load Multiple command that loads them together in the proper order. For a Load Multiple command, the order in which the entities are loaded is specified by the order that the entity names appear in the selection list file.

You could also load these entities from an exception build source file (.EB file). In the .EB file, entities must be listed in the proper order.

2.4 HIWAY CONFIGURATION

The emulated Data Hiway in an EPLCG is not a physical process network, so the EPLCG does not have remote or added gateways, as does the Hiway Gateway.

2.4.1 Hiway Number

Each pair of EPLCGs (a primary and secondary) on an LCN is assigned a unique process network number (01 through 20). The process network number identifies the hiway database to be used by the EPLCG pair.

2.4.2 Hiway Traffic Director Functions

Because there is no physical Data Hiway associated with an EPLCG or EPLCG pair, the EPLCG has complete control over all transactions on the emulated Data Hiway, so a Hiway Traffic Director (HTD) is physically impossible and functionally unnecessary. Therefore, always select ThisHG as the value for parameter HWYHTD in the hiway entity.

2.4.3 Sequence-of-Events Synchronization

The EPLCG does not support sequence-of-events synchronization, therefore, always select Disable as the value for parameter SOESYNCH in the hiway entity.

2.5 BOX/SLOT CONFIGURATION

The type of box on the Data Hiway (HG for the EPLCG and DHP for the emulated boxes) is defined in this task, as is each device's address on the hiway. You must configure a box/slot entity for each EPLCG in an EPLCG pair and you must configure a box/slot entity for each DHP for which you intend to build data points.

After selecting BOX/SLOT CONFIG for the BOXTYPE parameter, select HG to configure an EPLCG box/slot entity; and select DHP to configure a DHP box/slot entity.

2.5.1 EPLCG Data Hiway Addresses

Assign the first EPLCG to hiway address 02 and assign its partner (if present) to hiway address 03.

2.5.2 Emulated DHP Hiway Address Assignments

Assign the emulated DHPs to hiway addresses 08 through 15.

2.5.3 EPLCG and DHP Box Assignment

The EPLCG does not support remote or added gateways, as does the HG, so always configure ThisHG as the value for the BOXASSN parameter in both the EPLCG box/slot entities and the DHP box/slot entities.

2.5.4 Event Processing

The emulated DHPs support the generation and reporting of events (Process Alarms, Process Changes, etc.). The parameter "EVENT PRC" should be set to "ENABLE" to allow routing of these events through the EPLCG to the LCN.

2.5.5 Change Detection

Because there are no other Masters on the Emulated Hiway in the EPLCG, there is no need to signal or detect changes made by other Masters. The “CHNG FLAG” parameter should be set to “NOT CONFIG.”

EPLCG OPERATIONAL CONSIDERATIONS

Section 3

This section describes operational characteristics of PLC Gateways (EPLCGs) that you should consider during EPLCG implementation.

3.1 THE EPLCG SUBSYSTEM

The EPLCG appears to the remainder of the LCN-based system to be a Hiway Gateway (HG) with a Data Hiway and up to eight Data Hiway Ports. It is supported by the HG software with no modifications. Therefore, all standard displays, including status displays, Group displays, Detail displays, and Engineering Personality displays are the same as if the EPLCG was an HG, including all HG, Data Hiway, and DHP terminology.

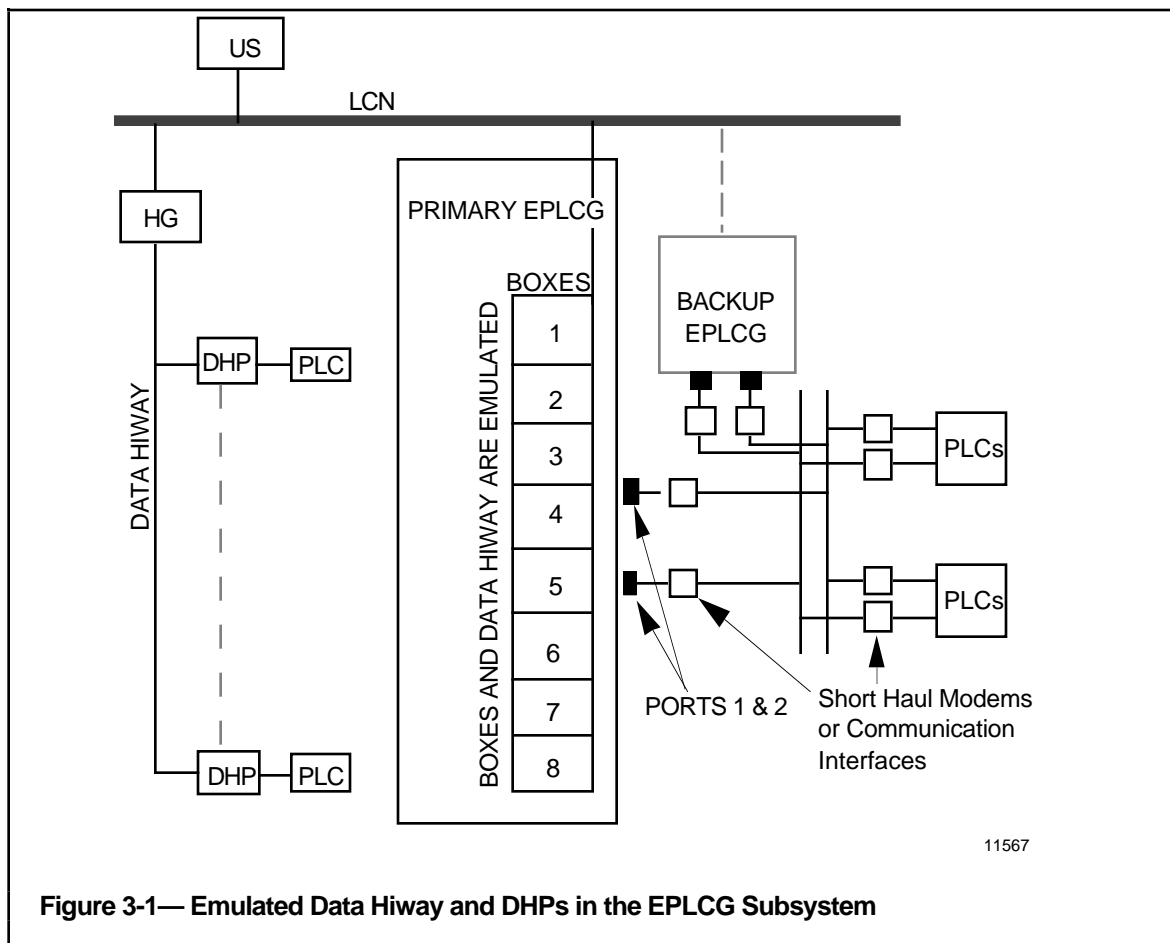

Figure 3-1— Emulated Data Hiway and DHPs in the EPLCG Subsystem

3.2 LOADING, SAVING, AND RESTORING OF EPLCG DATA

3.2.1 EPLCG Initial Startup or Restart

EPLCGs are loaded with software and data through the Gateways and Interfaces display, which is called up through the System Status display. On the Gateways and Interfaces display, select the node number (or pair of node numbers) for the EPLCG that is to start up as the primary EPLCG. Then select the appropriate node loading targets and follow the prompts to initiate loading of the EPLCG (select OPERATOR PROGRAM to load with the operating personality). After the status for the primary EPLCG goes to OK, you can initiate loading of the backup EPLCG. When it is loaded, its status becomes BACKUP.

The EPLCG is loaded with its software personality image and a data image. The data image consists of previously checkpointed data or null checkpoint (a set of Honeywell-provided checkpoint files with no point data). The data that is loaded from the Gateway and Interfaces display does not include data for the emulated DHPs, which is loaded or restored through the Hiway Status display (for more information, see subsection 3.2.2).

CAUTION

Do not try to load both EPLCGs in an EPLCG pair concurrently—one of the EPLCGs will fail. Complete loading one of the EPLCGs as the primary, then the other EPLCG can be loaded as the secondary.

For more information about starting or restarting EPLCGs, refer to the information about loading of gateways and HG modules in Section 15 of the *Process Operations Manual* in the *Process Operations* binder. For instructions for using null-checkpoints in the initial startup of an EPLCG, refer to Task 18 in the *System Startup Guide* in the *Implementation/Startup and Reconfiguration - 1* binder.

3.2.2 Initial Startup of an EPLCG

A summarized example of 10 steps required to start up an EPLCG are presented in this table. Publication references given in this section are here for convenience to the startup effort and some are duplicates of those in the list in subsection 1.2.

STEPS 1 THROUGH 4	NOTES	REFERENCE PUBLICATIONS
1. Physically install the EPLCG or redundant EPLCG pair; including power, grounding, and LCN cabling.	<ul style="list-style-type: none"> The connection between the EPLCG(s) and the PLC(s) will be discussed in a later step. 	*Refer to the publications listed by these letters below for useful information you may need to accomplish each task: A, B, C, D, E
2. Configure the EPLCG or EPLCG pair as a node or node pair on the LCN.	<ul style="list-style-type: none"> The EPLCG configures as a Hiway Gateway (HG) and looks exactly like an HG to the operator. If the EPLCG is redundant, you will need to enter the Redundant Node Number ID (the two digit LCN node number). You will be asked to enter a two digit Hiway number (01 - 20). 	* F, G, H, I, J
3. Perform a volume configuration to provide checkpoint space on a History Module within your system.	<ul style="list-style-type: none"> Although having a checkpoint on your LCN network is not absolutely mandatory (you could store it on removable media), it is highly recommended. Do not simply add a directory to an existing volume on an HM. 	* F, G, H, I, J
4. Complete the EPLCI board pinning in the EPLCG(s) and the EPLCG relay panel pinning on the back of the EPLCG(s).	<ul style="list-style-type: none"> EPLCG parity can be either odd or even, no parity is not an option. If you chose Redundant Allen-Bradley for the relay panel pinning, the port 1 and port 2 pinning of TS2 on the EPLCI board must be for identical baud rate and parity. 	* A

STEPS 5 THROUGH 8	NOTES	REFERENCE PUBLICATIONS
5. Complete the cabling between the EPLCG relay panel and the PLC(s).	<ul style="list-style-type: none"> This is a good time to complete any dip switch settings and/or configuration in the PLC(s) you are interfacing to. 	* A
6. Power on the EPLCG(s) and load it/them with the HG null checkpoint.	<ul style="list-style-type: none"> The null checkpoint files are on floppy volume &HGC, cartridges &CR6 or &C6. The directory names are &I01 through &I20 corresponding to the appropriate hiway number chosen. The file name that will be loaded is HG0xxMAS.CP where xx corresponds to the appropriate hiway number chosen. At the Gateway Status display, the EPLCG(s) should show as OK for the primary HG and Backup for the redundant HG (if present). 	* A, F, G, J
7. Build and load the EPLCG Hiway Data Point.	<ul style="list-style-type: none"> The EPLCG configures as a Hiway Gateway (HG) and looks exactly like an HG to the operator. 	* F, G, H, I, J, K
8. Build and load the EPLCG Box Data Point(s).	<ul style="list-style-type: none"> IMPORTANT - Do not build and load any of the EPLCG Box/Slot Data Points until this step is complete. The EPLCG configures as a Hiway Gateway (HG) and looks exactly like an HG to the operator. For the primary EPLCG, the box number has only one valid choice and it is 02. For the backup EPLCG, the box number has only one valid choice and it is 03. 	* F, G, H, I, J, K

STEPS 9 AND 10	NOTES	REFERENCE PUBLICATIONS
9. Build and load the EPLCG Box/Slot Data Point(s).	<ul style="list-style-type: none"> • IMPORTANT - Do not do this by exception building or the use of the load multiple command with IDFs. • WARNING - After the initial load of a DHP, there will be an associated A80 addressing error seen from the Hiway Status Display. To clear the error, perform an INIT ADDR command from the HIWAY COMMANDS function. <u>Then reload each and every Box/Slot Data Point again.</u> DO NOT PROCEED WITHOUT COMPLETING THIS PROPERLY. • Each emulated DHP should come up in the RESET mode. Performance of an ENABLE PROCESSING command should make each DHP go to an OK state. 	* F, G, H, I, J, K
10. Build and load Point(s).	<ul style="list-style-type: none"> • One point is enough to cause communications to start between the EPLCG(s) and a PLC. Thus it is recommended that only one point be built and loaded before going further. • Perform a demand checkpoint now. This way you will have something to go back to in case of a power failure or equipment malfunction. It is best to do a save using the ALL BOXES target to insure saving both the HG and DHP box portions of the database. 	* H, I, J, K, L, M

*Startup publications references:

PUBLICATION TITLE	BINDER TITLE
A. EPLCG Planning, Installation, and Service	Implementation/EPLC Gateway
B. EPLCG Specification and Technical Data	Implementation/EPLC Gateway
C. LCN Site Planning	System Site Planning
D. LCN System Installation	LCN Installation
E. LCN System Checkout	LCN Installation

PUBLICATION TITLE	BINDER TITLE
F. System Startup Guide - Floppy Drives	Implementation/Startup and Reconfiguration - 1
G. System Startup Guide - Cartridge Drives	Implementation/Startup and Reconfiguration - 1
H. EPLC Gateway Implementation Guidelines	Implementation/EPLC Gateway
I. Data Entity Builder Manual	Implementation/Engineering Operations - 1
J. Engineer's Reference Manual	Implementation/Startup and Reconfiguration - 2
K. EPLC Gateway Forms	Implementation/EPLC Gateway
L. EPLC Gateway Control Functions	Implementation/EPLC Gateway
M. EPLCG Parameter Reference Dictionary	Implementation/EPLC Gateway

3.2.3 Saving of EPLCG and DHP Data

After its initial startup, you can begin to build the database for your EPLCG(s), including the data points and hiway and box/slot entities described in Section 2. These entities (points) are built with the Data Entity Builder, which you activate by selecting HIWAY GATEWAY on the Engineering Main Menu.

As you load points into the EPLCG and during operation, you should periodically checkpoint (save) your EPLCG and DHP data on an HM or removable media (cartridges or floppies). Use the SAVE DATA target on the Hiway Status display to request a demand checkpoint. You can enable automatic, periodic checkpointing to an HM through the AUTO SAVE target on the Gateways and Interfaces display (you should disable periodic checkpointing while you are building data points). For more information on checkpointing, refer to Section 21 of the *Engineer's Reference Manual* in the *Implementation/Startup and Reconfiguration - 1* binder.

We recommend that, in addition to checkpoints being saved automatically on an HM, you periodically request demand checkpoints through the SAVE DATA target on the Hiway Status display to be stored on removable media. This will serve as backup data if the HM should become unavailable. We do not recommend copying checkpoint files from an HM to removable media, because if more than one cartridge or floppy is needed, the data for one unit may be split between cartridges or floppies, and such data cannot be reloaded.

NOTE

It is possible to save data for individual DHPs (boxes), but before you can do so, you must have saved a complete checkpoint for the EPLCG and all its emulated DHPs. Because the DHPs are not really individual physical boxes, but are integral parts of the EPLCG, it is probably best to select ALL BOXES, rather than individual boxes. This ensures that all data changes in the EPLCG and all DHPs are saved.

3.2.4 Restoring EPLCG and DHP Data

EPLCG and DHP data can be restored from checkpoint files through the LOAD DATA target on the Hiway Status display. A successful load replaces any data in the EPLCG and DHP(s) with data from the checkpoint files. These loads can be directed to any box (DHP), or you can select ALL BOXES to direct the load to all DHPs.

NOTE

After reloading the EPLCG personality, all configured DHPs will have A80 Address Errors. These errors must be cleared using the "INIT ADDR" command in the Hiway Command Menu from the Hiway Status Display. The configured DHPs will now be in "Reset." The DHP data can now be restored.

To accept a load, the EPLCG status on the Hiway Status display must be OK. The DHP status must be RESET or OK, and the box control state must be BASIC. When a load is completed successfully, the word RESTORED appears adjacent to the box's status indicator.

3.2.5 Recovering from Checkpointing and Loading Errors

The following error messages may appear on the Process Networks Node Status display or on the Hiway Status display when you attempt to save EPLCG checkpoint and box checkpoint data, when you attempt to load an EPLCG or boxes, or when you attempt to save box checkpoint data:

- FILE ERROR—See subsection 3.2.4.2.
- BAD REQUEST—A request was made for a box configured as AddedHG or RemoteHG, and not ThisHG. The EPLCG and all emulated DHPs must be configured as ThisHG.
- CONFLICT—The EPLCG is busy with another save or load operation.
- NO VOLUME—Either no medium (cartridge or floppy) is mounted in the drive specified, or the volume doesn't exist on the HM, or no checkpoint files were found on the specified medium (cartridge, floppy, or HM).
- BAD STATE—The box was not in a proper state to accept the command. See subsection 3.2.2.
- ????????????—A communication error or some other error occurred that prevents the Universal Station from displaying the correct status.

Some operations might terminate because of an error, such as a cartridge or floppy not mounted or a bad medium, and a message such as FAIL;HGnn appears. This doesn't mean the EPLCG failed, it's the operation that failed.

3.2.5.1. Recommended Actions for Error Recovery

1. Use the SCREEN PRINT function to print a copy of the Gateway Status display or the Hiway Status display. If boxes are involved, you may need to print more than one display to document both the HG status and box status.
2. Check the Real Time Journal print out(s) on the printer. This information will be useful if you need to consult with Honeywell about the problem. Error messages that result from these operations are in this form:

```
D$ CP CHPNT xx yy zz
```

5001 through 5063, where the last two digits are the number of the box that is involved, or 60nn, where nn is the HG file number, or 0 = the system "crashed."

Provides a cause-of-error indication.

Indicates the internal HG module name.

2958

3.2.5.2 Recovery from a FILE ERROR

A FILE ERROR message is caused by one of the following:

- An attempt to load a box that was not previously checkpointed.
- Needed checkpoint files were not found on the medium (cartridge, floppy, or HM) that was specified.
- A hiway error occurred as access to a box was attempted.
- On a SAVE DATA operation, the medium was full (too few files formatted) or the directory was too small to accept the data.
- An error occurred as access to the medium was attempted.

You should use the Catalog (LS or CAT) command in the Engineering Personality's Utilities to check the number of available files and sectors for the EPLCG checkpoint data. Use the command's detail (-d) option. See *Command Processor Operation* in the *LCN Implementation/Engineering Operations - I* binder.

You can determine if checkpoint data for a specific box is on the medium by using the Utilities List File Attributes (LS) command to find information for the HG0hhbbr.CP file for the box. It may be useful to check the time stamps that are in the catalog data to see if an incompatible time stamp may be causing a problem. For example, box data should not be older than EPLCG data.

3.3 EPLCG FUNCTIONS

3.3.1 Redundant Gateways

EPLCGs can be configured stand-alone or in redundant pairs. When configured as a redundant pair, the primary EPLCG uploads initial database information to, and synchronizes with, the secondary EPLCG, through the interboard link. The backup EPLCG will monitor the communication between the primary EPLCG and the PLC(s), thereby maintaining an up-to-date copy of the current database.

3.3.1.1 Interboard Link

The interboard link, an RS422, 38.4 Kbaud connection between the EPLCI I/O cards, allows firmware revision/compatibility checks between the primary and secondary EPLCGs to be performed immediately after self-tests have completed. If a PLCG and an EPLCG are configured as a redundant pair (not a legal configuration) a Hiway Error is posted and the gateways will not communicate with each other. If the PLCG is loaded first, the EPLCI will not fault (redundant self-test LED lit) and the EPLCG will not load.

3.3.2 Redundant Communications

The EPLCG can provide redundant communication paths to the PLC devices. If TS3, Pin 2 is configured for redundant communications, the two independent communication ports on the EPLCG will be reconfigured by the firmware to provide two alternate paths to the PLC data and the EPLCG will route traffic through whichever port comes ready first. Port 2 has a slightly higher priority level so a “tickle” timer causes Port 1 to be used every 15 seconds.

3.3.2.1 Port Management

If redundant communications mode is selected, port selection and recovery will be performed without operator or system software intervention. Should one path fail or become degraded, the EPLCG will automatically route traffic through the “good” port. Reconnect timers cause retries every 15 seconds. If the problem clears, normal routing resumes. If both ports are questionable, the EPLCG will route the traffic to both ports for 2 retries. If both ports fail, the EPLCG will route traffic alternatively between the 2 ports.

3.3.2.2 Keep Alive Writes

With Allen-Bradley protocol and redundant communications selected, redundant EPLCGs each have independent access to all PLCs, and Keep Alive writes to each PLC can be performed by both EPLCGs simultaneously. To provide each PLC with independent Primary/Secondary Keep Alive data, the primary EPLCG performs Keep Alive writes to the configured word and bit, while the secondary EPLCG writes to the configured word, but to the configured (bit + 8) Modulo 16. This causes the Secondary to use the byte opposite to the one used by the Primary. If the Primary is configured to use bits 0 - 7, the Secondary will use bits 8 - 15. If the Primary is writing to bits 8 - 15, the Secondary will use 0 - 7. This will allow the PLC programmer to create intelligent fall-back or indication schemes as needed. Using Modbus protocol the backup EPLCG does not have independent access to the PLCs, so only the primary can perform Keep Alive writes.

3.3.2.3 Reconnect Lockout

After the EPLCG determines that an Allen-Bradley PLC is not visible on either port, reconnect attempts are locked-out for a 1-second period. At the end of the 1-second lock-out, a reconnect will be attempted. On one port, if it is unsuccessful, the 1-second lock-out will be triggered again and the next attempt will be made using the other port. This sequence will repeat as long as necessary. The 1-second lock-out prevents the EPLCG from overloading this A-B network during reconnect attempts.

3.3.2.4 Best View Failover

The Allen-Bradley Data Hiway protocol allows multiple masters, and with redundant communications selected, each redundant EPLCG maintains an indicator of the number of visible PLCs. These indicators are compared and, if the back-up EPLCG has a better view for a predetermined time (20 seconds at present), the primary will shutdown allowing the backup to take over and provide the system with the better view. When this occurs a digital status bit will be set to indicate that the failover was caused by best view. Modbus protocol does not allow multiple masters, and since EPLCGs must share access to PLCs, primary selection by best view cannot be performed in the Modbus redundant communications environment.

3.3.2.5 Logical ASCII Addressing with Redundant Communications

When the redundant communications option of an EPLCG is enabled, Allen-Bradley PLC-5 series controllers should be configured using the “APLC215” target. The use of “APLC215” with redundant communications causes the EPLCG firmware to use the Logical ASCII addressing mode to bypass the PLC-5’s default PLC-2 emulation file processing. Numeric data is still transferred in binary format. Keying the use of the “APLC215” target with the redundant communications option was done to remain backwards compatible with existing PLCG installations. Selecting “APLC215” without redundant communications will condition the EPLCG to expect a member of the PLC-2 series and numeric data to be transferred in BCD format.

3.3.3 Reporting by Exception in Allen-Bradley PLCs

To reduce the communication load presented to Allen-Bradley PLCs by the EPLCG, the PLC’s exception-reporting feature can be used. If this option is chosen, after the initial PLC data has been scanned by the EPLCG, it expects PLCs to notify it of significant changes in the PLC data by sending unsolicited inputs to the EPLCG.

To avoid undetected loss of communication from the PLCs, keep-alive PLC addresses and bits must be configured in the box/slot entity for the DHP serving each Allen-Bradley PLC (parameters PCnALIVE AND PCnALVBT, where n = PLC numbers 1 through 8). If communication of a keep-alive bit fails, the EPLCG places all points in the target PLC on continuous scan until the data is reestablished, and all data points that reference that PLC fail. Once communication is reestablished and new values are obtained, reporting by exception resumes.

If this option is chosen, the ladder-logic program in the PLC must support reporting by exception and must initiate all such reporting. Because periodic scanning of the PLC data is not occurring, changes by Universal Station operators and user-written programs must be reported back to the EPLCG by the PLC. If it is not, the operators or user-written programs will not be able to see the status changes.

3.3.3.1 Activating Reporting by Exception

To activate reporting by exception, add two to the port address in the PCnPORT parameter (n = PLC number, 1 through 8). A port address of 1 or 2 specifies that the PLC is connected to ports 1 or 2, respectively, and that continuous scanning of the PLCs is configured. A port address of 3 or 4 specifies that the PLC is connected to ports 1 or 2, respectively, and that reporting by exception from the PLCs is configured.

3.3.3.2 Digital Input Status Points

The EPLCG provides a total of 11 system visible Digital Input points. These points are located in slot 31 of each emulated DHP and are updated once per second. To prevent conflict with user-configured points, the following conditions must be met:

1. The emulated DHP must be processing (on-scan).
2. Slot 31 must be configured as a digital input slot.
3. Each port status digital input subslot must be configured as an empty subslot (word 0 and bit 0 for Allen-Bradley or address 0 and specifier 0 for ModBus).

To make these digital input status points visible to the TDC 3000^X system, a tag must be built for each point. The tag's name can be anything the user wishes. Once built, the digital input status points may be referenced by tag name anywhere the system allows a digital input point.

3.3.4. MODBUS Digital Output Scan Suppression

Because the jumper (TS3, Pin 2) used to select nonscanning Modbus Digital Outputs has been reassigned, an alternate method of configuring these points has been provided. Scan suppression of Modbus Digital Outputs is now a software configuration option. The selection of nonscanned Modbus outputs is made in a manner similar to the selection of Allen-Bradley report-by-exception. To create a nonscanning Modbus output (analog or digital), the programmer must first create a logical Modbus PLC configured on the actual port + 2 (port 3 or 4). Then configure any nonscanned output points against this logical PLC. Any attempt to configure an input point (analog, digital, or counter) against a nonscanning logical PLC will result in a configuration error being returned.

3.3.4.1 Use of Holding Registers in Modicon PLCs

The holding registers in Modicon and Modicon-compatible PLCs can be used as sources of EPLCG digital input data, thereby increasing throughput by transferring blocks of digital data rather than single bits. To do so, a Digital Input or Digital Composite point's subslot address in parameter INPTSSLT specifies the bit to input from the holding register, as follows:

Subslot number in INPTSSLT	16	15	14	-----	02	01
Holding register bit number	16	15	14	-----	02	01

EPLCG PERFORMANCE CONSIDERATIONS

Section 4

4.1 FACTORS LIMITING PERFORMANCE

Although it is a very fast processor of data, the EPLCG has finite computational capacity as its upper limit. If the processing of input/output data is restricted by the EPLCG's inability to perform required computations, it is known as "compute bound." Limiting factors at the other extreme are baud rate and PLC I/O delays. If computations must wait for data to be received or transmitted, the condition is called "I/O bound." As baud rate is increased and/or PLC I/O delays are decreased, performance improvement is linear and usually proportionate. The performance improvement degrades, however, as compute limits are approached.

Statistics are maintained at various levels that can be used to monitor the performance of the EPLCG. See *EPLCG Planning, Installation, and Service* manual, subsection 4.3.2 for details and section 4.3 for how to display them.

4.2 EFFECTS OF DATABASE COMPOSITION

The performance of a database chiefly composed of analog inputs, analog outputs, and/or counters (numeric points) is primarily limited by baud rate and PLC performance. This is because numerics are easily processed in less than the 16-bit times required to transmit them to the EPLCG. The performance of a database which is predominantly digital inputs and digital outputs (Boolean points) places a greater burden on computational power because only 1-bit time is available for processing.

4.3 ADJUSTING AN EPLCG FOR PERFORMANCE

Of the factors affecting EPLCG performance, the most significant is baud rate. As a rule of thumb, doubling the baud rate will double performance. If you are already running at the maximum baud rate, consider dividing the database between the EPLCG's two ports, if possible. When pinned for redundant communications, the EPLCG will automatically divide data requests between the two ports. This has the same effect as doubling the baud rate. Pinning the EPLCI board to double buffer Data Requests (pipelined operation) will also improve performance. See *EPLCG Planning, Installation, and Service* manual, subsection 3.2.3.4, for pinning information.

At the PLC end, a dedicated communications module should be used if supported by the PLC. These modules usually contain a dedicated processor that utilizes a high-speed access mechanism, such as DMA, to access the PLC data. The EPLCG requests data in blocks of up to 64 words. Unused data elements in the block will be read and discarded. For example: two 30-word blocks separated by 4-unused words will be collected as a single 64-word block. This is faster than two 30-word requests. If a 60-word block is preceded or followed by unused words, only the 60-word block will be requested. By using consecutive storage elements within the PLC, the amount of excess data requested by the EPLCG can be reduced.

The EPLCG will sort all PLC database addresses before starting to request data, so the order of the points in the emulated DHP is not critical. As long as the PLC data elements are contiguous, the desired result will be achieved.

Index

Topic	Section Heading
Actions for Error Recovery	3.2.5.1
Activating Reporting by Exception	3.4.1
Addresses	
Assignments for Emulated DHP	2.5.2
EPLCG	2.5.1
Adjusting a EPLCG for Performance	4.3
Allen-Bradley PLCs, Reporting by Exception	3.4
Assignment, Box, EPLCG and DHP	2.5.3
Box Assignment, EPLCG and DHP	2.5.3
Box/Slot and Hiway Entities	
To be Built	2.2
Purpose	2.1
Building Order	2.3
Configuration	2.5
Box/Slot Configuration and Hiway Configuration	2
Building Order for Hiway and Box/Slot Entity	2.3
Change Detection and Event Processing	2.5.4
Checkpointing	
Loading Errors	3.2.5
EPLCG Data	3.2
EPLCG and DHP Data	3.2.3
Configuration	
Box/Slot	2.5
Hiway	2.4
Data Hiway Addresses, EPLCG	2.5.1
Data Restoration	3.2.4
Dependencies, Implementation	1.3
DHP	
Box Assignment	2.5.3
Hiway Address Assignments	2.5.2
Effects of Database Composition	4.2
Emulated DHP Hiway Address Assignments	2.5.2
Entities	
Hiway and Box/Slot	2.2
Box/Slot	2.2.2
Hiway	2.2.1
EPLCG Functions	3.3
Redundant Gateways	3.3.1
Interboard Links	3.3.1.1
Redundant Communications	3.3.2
Port Management	3.3.2.1
Keep-Alive Writes	3.3.2.2
Reconnect Lockout	3.3.2.3
Best View Failover	3.3.2.4
Logical ASCII Addressing with Redundant Communications	3.3.2.5
Reporting by Exception in Allen-Bradley PLCs	3.3.3
Activating Reporting by Exception	3.3.3.1
Digital Input Status Points	3.3.3.2
Modicon Digital Output Scan Suppression	3.3.4
Use of Holding Registers in Modicon PLCs	3.3.4.1
Error Recovery	3.2.5.1
Event Processing	2.5.4
Events, Sequences of	2.4.3
Exception Reporting	
Activation of	3.4.1
In Allen-Bradley PLCs	3.4
Factors Limiting Performance	4.1

Index

Topic	Section Heading
FILE ERROR Recovery	3.2.5.2
Hiway Address	
Emulated DHP	2.5.2
EPLCG	2.5.1
Hiway and Box/Slot Entities	
Building Order	2.3
Purpose	2.1
To be Built	2.2
Hiway	
Configuration	2.4
Entities	2.2.1
Number	2.4.1
Hiway Traffic Director (HTD) Functions	2.4.2
Implementation	
Dependencies	1.3
Tasks, Summary of	1.1
Initial Startup or Restart	3.2.1
Initial Startup of a EPLCG	3.2.2
Installation and Checkout	1.2.2.2
Introduction	1
Loading and Checkpointing Errors	3.2.5
Loading, Saving, and Restoring of EPLCG Data	3.2
Logical ASCII Addressing with Redundant Communications	3.3.2.5
Modicon PLCs, Holding Registers	3.3
Number, Hiway	2.4.1
Operational Considerations	3
Order for Hiway and Box/Slot Entity Building	2.3
EPLCG	
Box Assignment	2.5.3
Data Hiway Addresses	2.5.1
Initial Startup of a EPLCG	3.2.2
Initial Startup or Restart	3.2.1
Operational Considerations	3
Performance Considerations	4
Subsystem	3.1
Publication References	1.2
Purpose of the Hiway and Box/Slot Entities	2.1
Recommended Actions for Error Recovery	3.2.5.1
Recovery	
Checkpointing and Loading Errors	3.2.5
Errors	3.2.5.1
FILE ERROR	3.2.5.2
References	1.2
Engineering Activities	1.2.1
Hardware Implementation	1.2.2
Registers, Holding, in Modicon PLCs	3.3
Reporting by Exception in Allen-Bradley PLCs	3.4
Activation of	3.4.1
Restart or Startup	3.2.1
Restoring	
EPLCG and DHP Data	3.2.4
Saving of EPLCG and DHP Data—Checkpointing	3.2.3
Saving, Loading, and Restoring of EPLCG Data	3.2
Sequence-of-Events Synchronization	2.4.3
Service	1.2.2.3
Site Planning	1.2.2.1
Startup or Restart	3.2.1

Index

Topic	Section Heading
Subsystem, EPLCG	3.1
Summary of EPLCG Implementation Tasks	1.1
Synchronization, Sequences of Events	2.4.3
Tasks, Implementation, Summary	1.1
Ten Steps to Start Up an EPLCG	3.2.2
The EPLCG Subsystem	3.1
Use of Holding Registers in Modicon PLCs	3.3

READER COMMENTS

Honeywell IAC Automation College welcomes your comments and suggestions to improve future editions of this and other publications.

You can communicate your thoughts to us by fax, mail, or toll-free telephone call. We would like to acknowledge your comments; please include your complete name and address

BY FAX: Use this form; and fax to us at (602) 313-4108

BY TELEPHONE: In the U.S.A. use our toll-free number 1*800-822-7673 (available in the 48 contiguous states except Arizona; in Arizona dial 1-602-313-5558).

BY MAIL: Use this form; detach, fold, tape closed, and mail to us.

Title of Publication: **EPLCG Implementation Guidelines** Issue Date: **9/95**

Publication Number: **EP12-500**

Writer: **G. Danner**

COMMENTS: _____

RECOMMENDATIONS: _____

NAME _____ DATE _____
TITLE _____
COMPANY _____
ADDRESS _____
CITY _____ STATE _____ ZIP _____
TELEPHONE _____ FAX _____

(If returning by mail, please tape closed; Postal regulations prohibit use of staples.)

Communications concerning technical publications should be directed to:

Automation College
Industrial Automation and Control
Honeywell Inc.
2820 West Kelton Lane
Phoenix, Arizona 85023-3028

FOLD

FOLD

From: _____



NO POSTAGE
NECESSARY
IF MAILED
IN THE USA

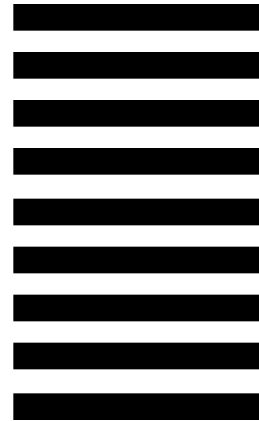

Cut Along Line

BUSINESS REPLY MAIL
FIRST CLASS PERMIT NO. 4332 PHOENIX, ARIZONA

POSTAGE WILL BE PAID BY

Honeywell

Industrial Automation and Control
2820 West Kelton Lane
Phoenix, Arizona 85023-3028

Attention: Manager, Quality

FOLD

FOLD

Additional Comments:

Honeywell

Industrial Automation and Control
Honeywell Inc.
16404 North Black Canyon Highway
Phoenix, Arizona 85023-3033

Helping You Control Your World