

FSC Safety Manager Installation Guide

for use with the Honeywell FSC System

Release 400

FS20-500

**Implementation
FSC Safety Manager**

***FSC Safety Manager
Installation Guide***

for use with the Honeywell FSC System

Release 400

FS20-500

09/96

Copyright, Notices, and Trademarks

© Copyright 1996 by Honeywell Inc.

Revision 02 – September 24, 1996

While this information is presented in good faith and believed to be accurate, Honeywell disclaims the implied warranties of merchantability and fitness for a particular purpose and makes no express warranties except as may be stated in its written agreement with and for its customer.

In no event is Honeywell liable to anyone for any indirect, special or consequential damages. The information and specifications in this document are subject to change without notice.

TotalPlant, TDC 3000 and Universal Control Network are U.S. registered trademarks of Honeywell Inc.

FSC is a registered trademark of Honeywell Safety Management Systems.

Other brand or product names are trademarks of their respective owners.

Honeywell
Industrial Automation and Control
Automation College
2820 West Kelton Lane
Phoenix, AZ 85023

(602) 313-5669

About This Publication

This publication includes both general and detailed installation information for the various major components of the FSC Safety Manager (FSC-SM) for use with the Honeywell FSC system release 400. Specifically included are:

- general installation instructions for the FSC Safety Manager (FSC-SM) system,
- detailed installation instructions for installing the FSC Safety Manager Module (FSC-SMM), and
- general installation instructions for the FSC-SM system.

Site planning information is contained in the *TotalPlant Solutions (TPS) System Site Planning Manual*, which is in the *System Site Planning* binder. After installation of the FSC-SM, the checkout procedure can be found in the *FSC Safety Manager Service Manual*, which is in this binder.

This publication supports TotalPlant® Solutions (TPS) System network Release 500. TPS is the evolution of TDC 3000^X.

All references in this manual to “FSC Safety Manager” or “FSC Safety Manager Module” pertain only for use with the Honeywell FSC system.

Table of Contents

SECTION 1 – FSC SAFETY MANAGER SYSTEM INSTALLATION.....	1
1.1 Section Overview	1
1.2 Equipment Warehousing	2
1.3 Move Preparation	3
1.4 Unpacking and Placement.....	13
SECTION 2 – SYSTEM COMPONENT INSTALLATION	21
2.1 Section Overview	21
2.2 Installation Considerations	22
2.3 Cabinet Installation	23
2.4 Cabling Considerations	24
2.5 Cabling Installation.....	29
2.6 System Power Connections	34
2.7 System Ground Connections	36
2.8 UCN Connections.....	39
SECTION 3 – SYSTEM COMPONENT CONFIGURATION.....	43
3.1 Section Overview	43
3.2 System Configuration Overview.....	44
3.3 Module Configuration.....	45
SECTION 4 – CONFIGURATION.....	47
4.1 Section Overview	47
4.2 FSC-DS Configuration.....	48
4.3 US Configuration.....	49
APPENDIX A – FSC-SMM DATA POINT CONFIGURATION DISPLAYS.....	59
A.1 Overview.....	59
A.2 Analog Input.....	60
A.3 Analog Output	62
A.4 Digital Input.....	64
A.5 Digital Output.....	67
A.6 Digital Composite.....	68
A.7 Logic.....	72
A.8 Flag	75
A.9 Timer	77
A.10 Numeric.....	79

Figures

Figure 1-1	Typical Electronics Room Layout.....	3
Figure 1-2	Location and dimensions of the cabinet bolt-down holes	6
Figure 1-3	FSC-SM cabinet with back access (FTA-T)	7
Figure 1-4	FSC-SM cabinet with front access (FTA-T).....	8
Figure 1-5	FSC-SM cabinet with front and back access (FTA-T)	9
Figure 1-6	FSC-SM cabinet with front access (FTA-E)	10
Figure 1-7	FSC-SM cabinet with back access (FTA-E).....	11
Figure 1-8	FSC-SM cabinet with front and back access (FTA-E).....	12
Figure 1-8	Placement of equipment onto lumber.....	14
Figure 1-9	Placement using a mobile lifter	16
Figure 1-10	Lifting equipment by mobile lifter of crane.....	17
Figure 1-11	Lifting equipment by mobile lifter of crane — part 2.....	18
Figure 1-12	Eyebolt crane method.....	19
Figure 2-1	FSC-SMM front plate	29
Figure 2-2	Redundant FSC-SM UCN cabling.....	30
Figure 2-3	Typical routing layout of internal wiring between I/O modules and FTA-T via SICs.....	31
Figure 2-4	Typical routing layout of internal wiring between I/O modules and FTA-E via SICs.....	32
Figure 2-5	FSC Safety Manager cabinet power connections	34
Figure 2-6	Connection of the UCN	40
Figure 4-1	US System Status display.....	51
Figure 4-2	US Engineering Main Menu display	52
Figure 4-3	US NIM Build Type Select Menu.....	53
Figure 4-4	US UCN Node Configuration display.....	54
Figure 4-5	US Node-Specific Configuration display.....	55
Figure 4-6	US Process Point Building display.....	56

Tables

Table 1-1	Move preparation checklist.....	4
Table 1-2	Move preparation checklist – part 2.....	5
Table 1-3	Important unpacking considerations.....	13
Table 1-4	Fork lift considerations.....	14
Table 1-5	Mobile lifter considerations.....	15
Table 1-6	Roller method considerations.....	18
Table 2-1	FSC system installation checklist.....	22
Table 2-2	Raceway shielding	24
Table 2-3	IEEE 518 wiring classification definitions	25
Table 2-4	Tray spacing	26
Table 2-5	Tray/conduit spacing.....	26
Table 2-6	Conduit spacing.....	27
Table 2-7	Cabling guidelines.....	28
Table 2-8	System grounding considerations	36
Table 4-1	Start-up and reconfiguration procedures	49
Table 4-2	UCN configuration	50
Table 4-3	UCN node configuration.....	53
Table 4-4	FSC-SMM data point configuration procedure.....	57

Acronyms

AC	Alternating Current
CP	Central Part
CPU	Central Processor Unit
DBM	Diagnostic and Battery Module
DC	Direct Current
DCS	Distributed Control System
EMI	Electromagnetic Interference
EPROM	Erasable Programmable Read-Only Memory
ESD	Electrostatic Discharge
FLD	Functional Logic Diagram
FSC	Fail Safe Control
FSC-DS	FSC Development System
FSC-SM	FSC Safety Manager
FSC-SMM	FSC Safety Manager Module
FTA	Field Termination Assembly
HM	History Module
I/O	Input/Output
IEEE	Institute of Electrical and Electronic Engineers
LCN	Local Control Network
LED	Light Emitting Diode
NCF	Network Configuration File
NIM	Network Interface Module
PLC	Programmable Logic Controller
SIC	System Interconnection Cable
SM	Safety Manager
SMM	Safety Manager Module
TAC	Technical Assistance Center
TPS	TotalPlant Solution
TTL	Transistor - Transistor Logic
UCN	Universal Control Network
US	Universal Station
VBD	Vertical Bus Driver
WD	Watchdog

References

For TotalPlant Solution (TPS) documentation:

Publication Title	Publication Number	Binder Title	Binder Number
<i>FSC Safety Manager Control Functions</i>	FS09-500	Implementation FSC Safety Manager	TPS 3076
<i>FSC Safety Manager Installation Guide</i>	FS20-500	Implementation FSC Safety Manager	TPS 3076
<i>FSC Safety Manager Parameter Reference Dictionary</i>	FS09-550	Implementation FSC Safety Manager	TPS 3076
<i>FSC Safety Manager Configuration Forms</i>	FS88-500	Implementation FSC Safety Manager	TPS 3076
<i>FSC Safety Manager Service Manual</i>	FS13-500	Implementation FSC Safety Manager	TPS 3076

For FSC documentation:

Publication Title	Publication Number	Version
<i>FSC Safety Manual</i>	PM.MAN.8047	400
<i>FSC Hardware Manual</i>	PM.MAN.8048	400
<i>FSC Software Manual</i>	PM.MAN.8025	400

Section 1 – FSC Safety Manager System Installation

1.1 Section Overview

About this section This section provides general installation information for the FSC Safety Manager (FSC-SM) system. Topics included in this section are:

Subsection	Topic	See Page
1.1	Section Overview	1
1.2	Equipment Warehousing	2
1.3	Move Preparation	3
1.4	Unpacking and Placement	13

Tools and test equipment

The following equipment is necessary for installation of the FSC Safety Manager:

- Mobile lifter/lift truck — refer to Subsection 1.4 (*Unpacking and Placement*),
- Carrier band MAP tester — refer to Subsection 2.2 (*Installation Considerations*),
- Hand tools and multimeter, as in a typical electrician's tool kit,
- UCN Connector Torque Wrench Kit (51109612-100),
- Set of SAE (inch) "crow's foot" wrenches for the above torque wrench,
- ESD kit (Honeywell part number 30185-H).

ATTENTION

ATTENTION — Installation of the FSC Safety Manager may **only** be carried out by qualified and authorized personnel. Failure to comply with the regulations and recommendations contained in this document may cause severe damage to the equipment or serious injury to people.

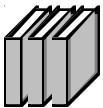

REFERENCE — For detailed information regarding

- site planning and installation, refer to SM02-550 *TPS System Site Planning Manual* in Binder TPS 3020-1 *System Site Planning-1*.
 - post-installation checkout procedures, refer to the *FSC Safety Manager Service Manual* in this binder.
-

1.2 Equipment Warehousing

Factory packing

For shipment, the FSC Safety Manager is packed with desiccant packages, wrapped in a moisture barrier and optionally enclosed for shipment as required by the user.

Transit/warehousing specifications

The FSC Safety Manager can be shipped by a variety of means, but any trucking should be done by enclosed air-ride electronic vans. The equipment is usually trucked on the final leg of the journey to the user warehouse or site. There it is stored off the ground on a solid piece or combination of lumber pieces (minimum height 10 cm) and indoors until needed for installation. During the whole process, the environment must be monitored and corrected if the following equipment transit/storage ratings are exceeded:

- Temperature range: -20° to 70°C (-4° to 158°F)
- Relative humidity: 5% to 95%, non-condensing
- Vibration: 1 G, frequency 10-150 Hz (IEC 68-2-6)
- Shock: 15 G for 11 ms (IEC 68-2-27)

ATTENTION In order to minimize exposure to humidity, keep the factory wrapping intact during storage and transit. If it is necessary to unseal the equipment for customs or receiving, add more desiccant and reseal the package.

1.3 Move Preparation

Background

Several basic points need to be kept in mind when planning the movement and unpacking of FSC Safety Manager cabinets. They include the following:

- A single FSC Safety Manager cabinet is nominally 80 x 80 x 210 cm (32 x 32 x 83 inches),
- Lifting eye bolts, which are removable, add about 5 cm (2 inches) to the height, and
- Weight varies with options and can go as high as 385 kg (850 pounds) per cabinet.

As illustrated in Figure 1-1, a typical factory-assembled complex uses up to four such cabinets bolted together.

Figure 1-1 – Typical Electronics Room Layout

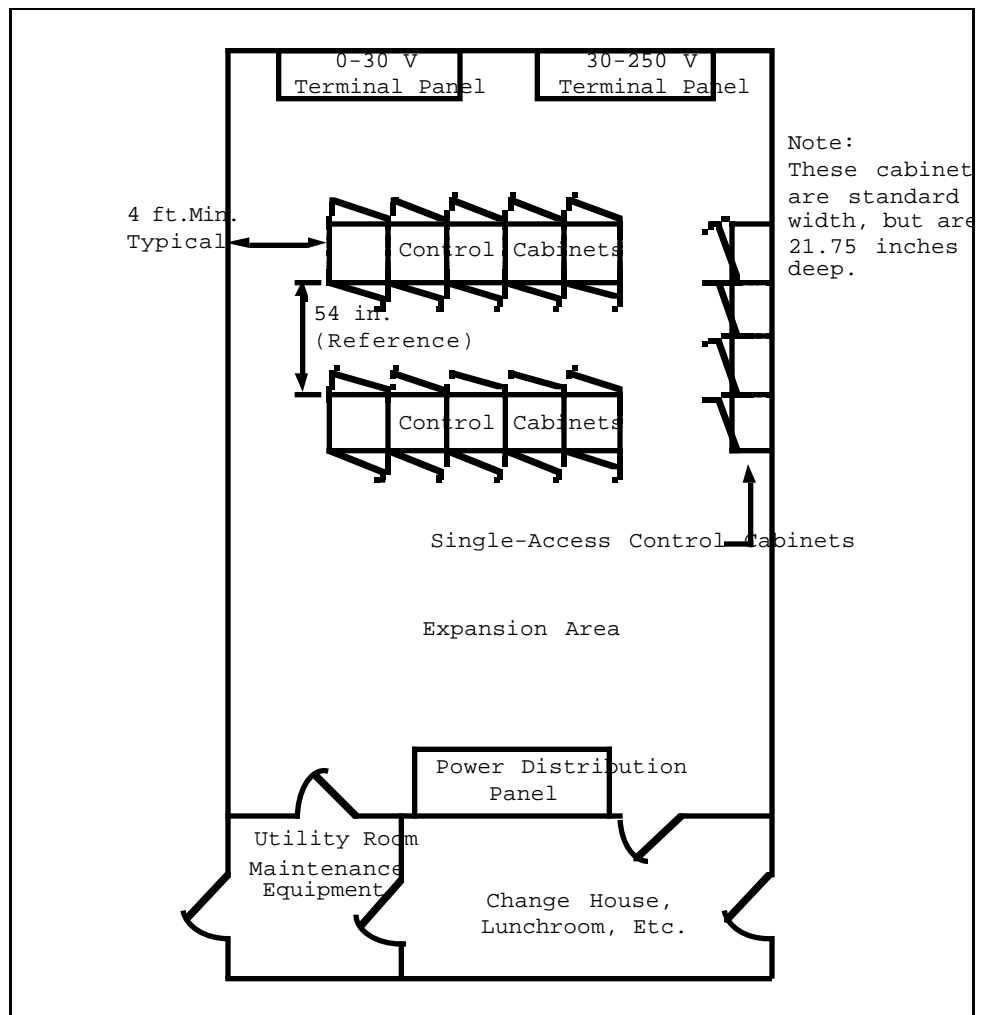

Continued on next page

1.3 Move Preparation, Continued

Checklist

Table 1-1 provides a checklist to be used when planning the movement of FSC Safety Manager cabinets.

Table 1-1 – Move preparation checklist

Check	Action	Notes
1	Travel Route	Chart the equipment's route of travel regarding: <ul style="list-style-type: none"> • loading doors — height and location, • elevators — size, capacity, and availability, • aisles — number, size, and layout, • doorways — number and size, • hallways — size, restrictions, and bends, • stairs and ramps — may require some type of lifting, and • rigging of equipment — if needed.
2	Space	Is there enough space to hold the equipment?
3	Floor Loading	Will the floor in all areas be strong enough?
4	Power Distribution	Check for proper transformer sizes, distribution panels and sufficient outlets for support, test and maintenance equipment.
5	Grounding	Be sure that proper grounds are available.
6	Conduits and Cable Trays	Make sure that conduits and cable trays are large enough and the proper type to accommodate all of the required cables.
7	Environment	Are lighting and other environmental requirements adequate?
8	Security	Provide security clearances for the installation crew if it is not composed of regular employees.
9	Responsibilities	Are all responsibilities clearly defined and understood?
10	Communications	At minimum, three conveniently located telephones are needed for: <ul style="list-style-type: none"> • Honeywell Technical Assistance Center (TAC) data terminal, • Honeywell TAC voice, and • Operator Emergency.

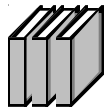

For additional information regarding actions described in the Move Preparation Checklist, refer to SM02-550 — *TPS System Site Planning Manual* in the Binder TPS 3020-1 *System Site Planning-1*.

1.3 Move Preparation, Continued

Preparation

Table 1-2 provides a checklist to be used when preparing the electronics room for the FSC Safety Manager cabinets.

Table 1-2 – Move preparation checklist – part 2

Check	Action	Notes
1	Static Electricity	Reduce the ESD-borne failures by: <ul style="list-style-type: none"> stripping the floors of any wax to prevent static charge buildup, using anti-static spray on floors, furniture and fabric in the work area, and placing a sign on or near the equipment that states circuit boards are not to be handled without wearing a ground strap.
2	Tack Rugs	Placed at all entrances, tack rugs catch dust, grit and abrasives from other areas.
3	Fire Prevention	Consult with the local fire prevention authority to select fire extinguishers suitable for electrical fires.
4	Room Layout	Prepare an electronics room layout diagram for cabinet placement. <ul style="list-style-type: none"> Refer to Figure 1-1.
5	Cabinet Bolt-Down	If this FSC Safety Manager cabinet is to be bolted down, pre-drill holes in the floor. ATTENTION Refer to Figure 1-2 for placement and dimensions of the bolt-down holes.

Continued on next page

1.3 Move Preparation, Continued

Bolt-down holes

Figure 1-2 provides the exact locations and dimensions of the cabinet bolt-down holes.

Figure 1-2 – Location and dimensions of the cabinet bolt-down holes

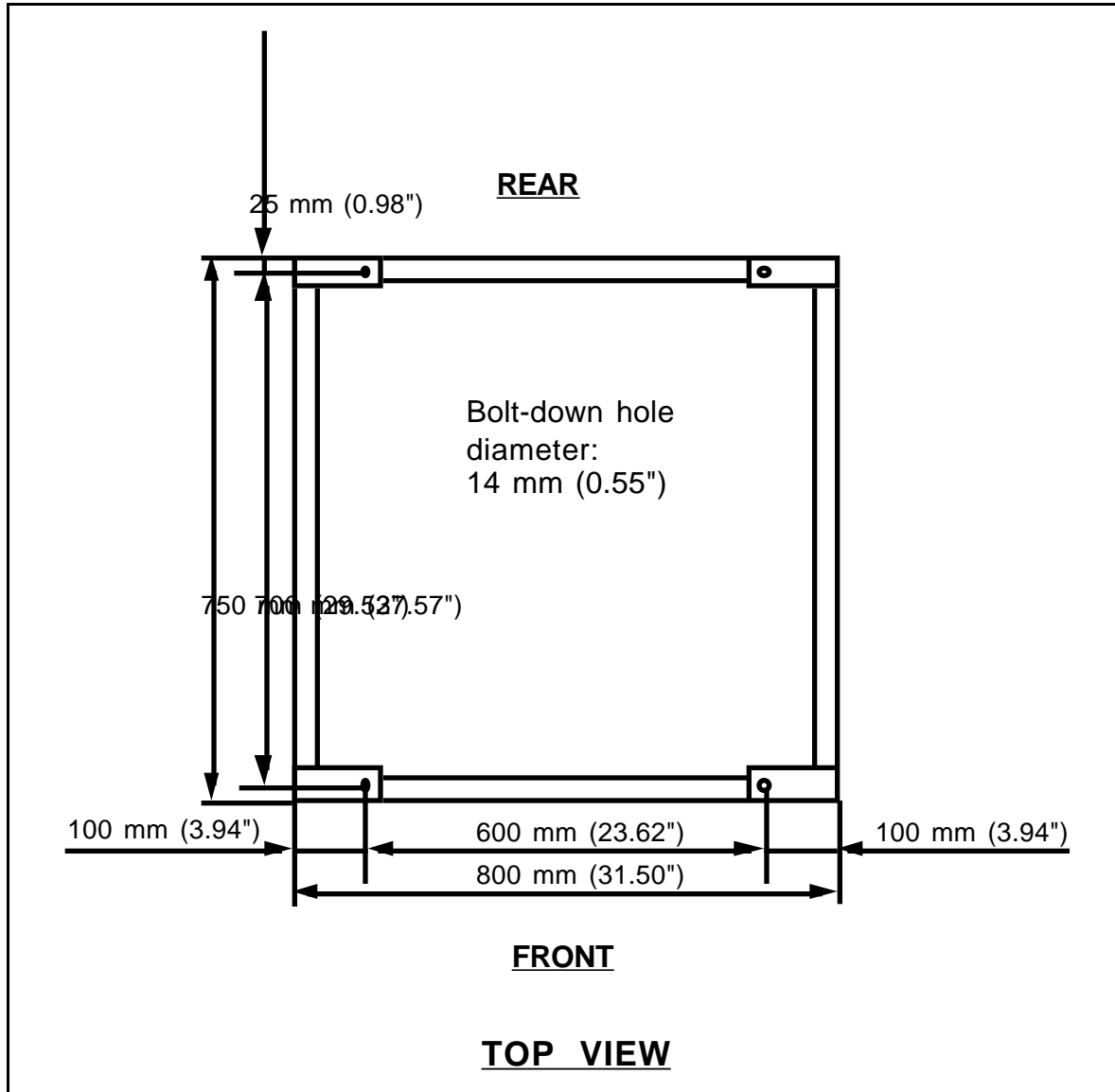

Continued on next page

1.3 Move Preparation, Continued

Cabinet entry

The process signal cables can enter the FSC Safety Manager cabinet through the top or bottom of the cabinet. The FSC-SM cabinet is prepared for field termination assembly to interface boards (FTA-E) or terminals (FTA-T). These interface boards or terminals may be located in the FSC-SM cabinet or in cross-wiring cabinets next to the FSC-SM cabinet. Figures 1-3 through 1-8 illustrate the placement and dimensions for process wiring for FTAs located in the FSC-SM cabinet.

The FSC-SM cabinet is also prepared for top **or** bottom entry as per user specification. For bottom entry, sliding floor plates are provided which can be adjusted to provide entry slots. For top entry, one sliding plate is provided which can be adjusted to provide entry slots. For top or bottom entry, the cables should be clamped firmly to the cabinet. The clamping devices should be able to withstand a 45 kg (100 lbs) pull. This prevents damage inside the cabinet when pulling on cables outside the cabinet.

The FSC-SM cabinet includes a cable clamp rail at the bottom or at the top.

Figure 1-3 illustrates an FSC-SM cabinet bottom configured for back access of the I/O field cables with FTA-T.

Figure 1-3 – FSC-SM cabinet with back access (FTA-T)

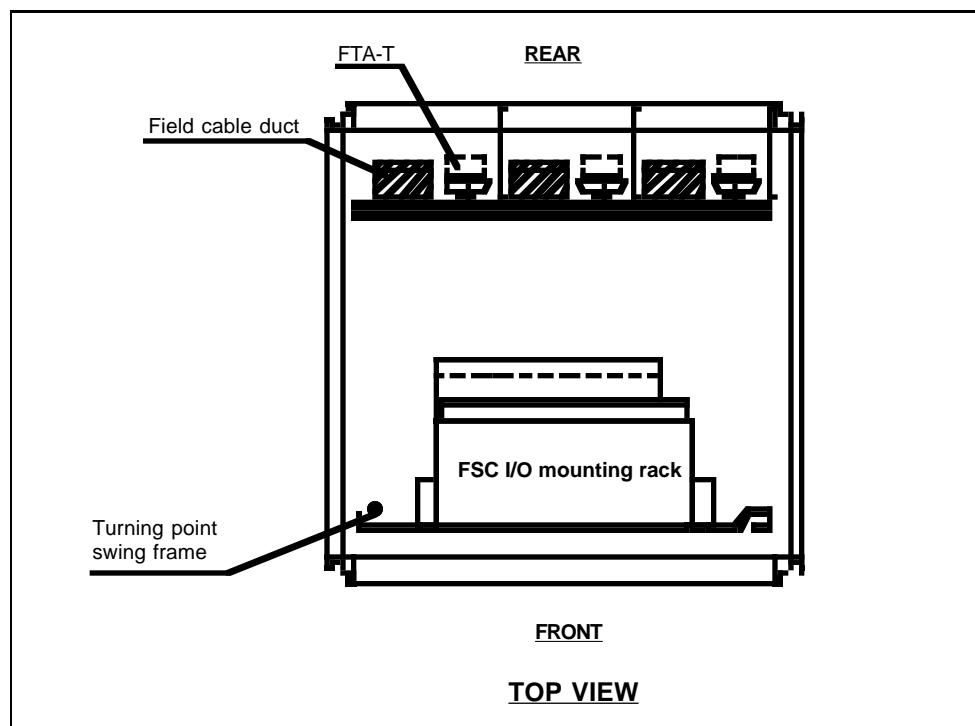

Continued on next page

1.3 Move Preparation, Continued

Cabinet entry,
continued

Figure 1-4 illustrates an FSC Safety Manager cabinet bottom configured for front access of the I/O field cables with FTA-T.

Figure 1-4 – FSC-SM cabinet with front access (FTA-T)

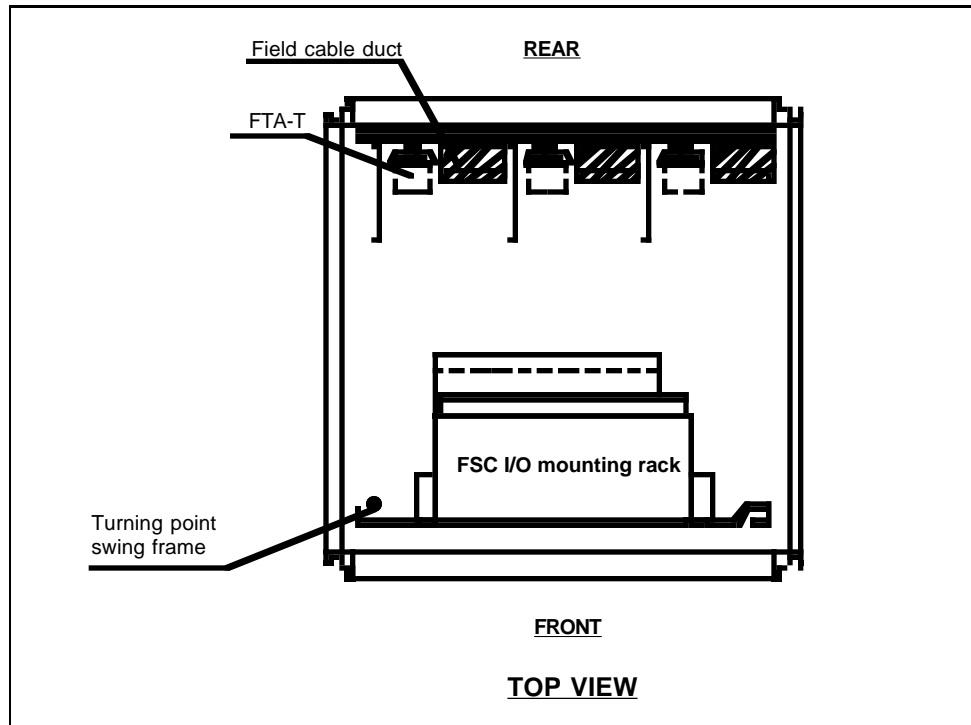

Continued on next page

1.3 Move Preparation, Continued

Cabinet entry,
continued

Figure 1-5 illustrates an FSC Safety Manager cabinet bottom configured for front and back access of the I/O field cables with FTA-T.

Figure 1-5 – FSC-SM cabinet with front and back access (FTA-T)

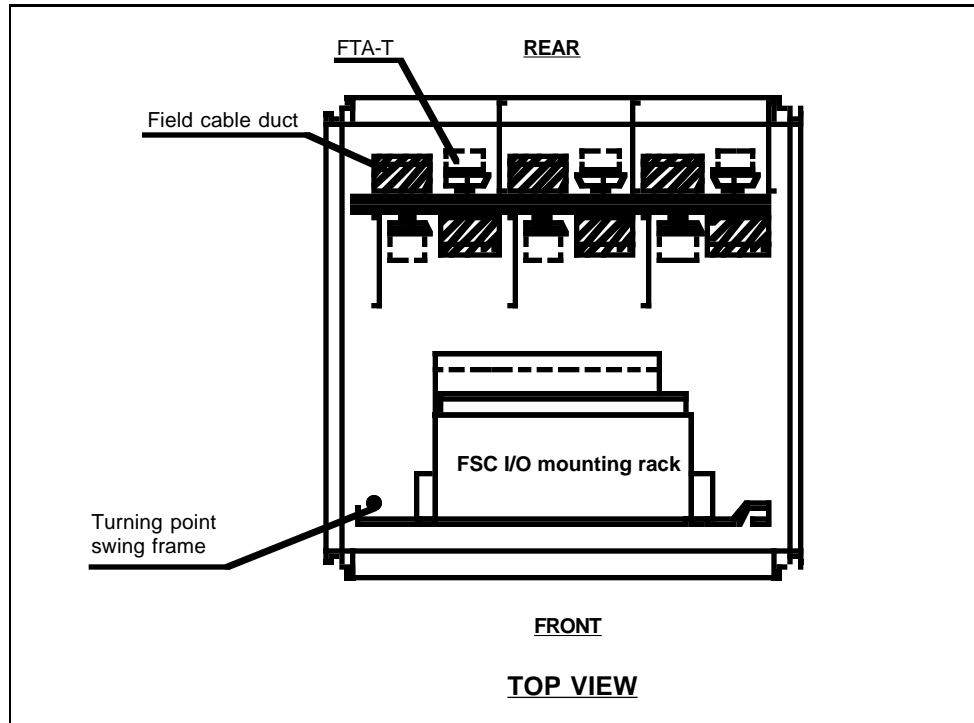

Continued on next page

1.3 Move Preparation, Continued

Cabinet entry,
continued

Figure 1-6 illustrates an FSC Safety Manager cabinet bottom configured for front access of the system cables with FTA-E.

Figure 1-6 – FSC-SM cabinet with front access (FTA-E)

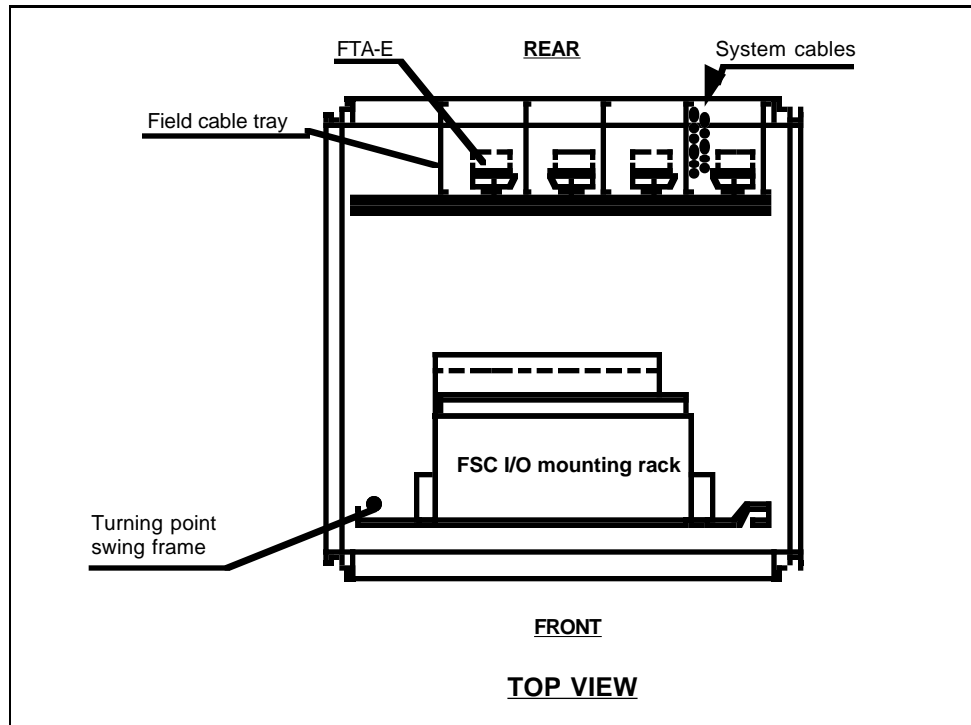

Continued on next page

1.3 Move Preparation, Continued

Cabinet entry,
continued

Figure 1-7 illustrates an FSC Safety Manager cabinet bottom configured for back access of the system cables with FTA-E.

Figure 1-7 – FSC-SM cabinet with back access (FTA-E)

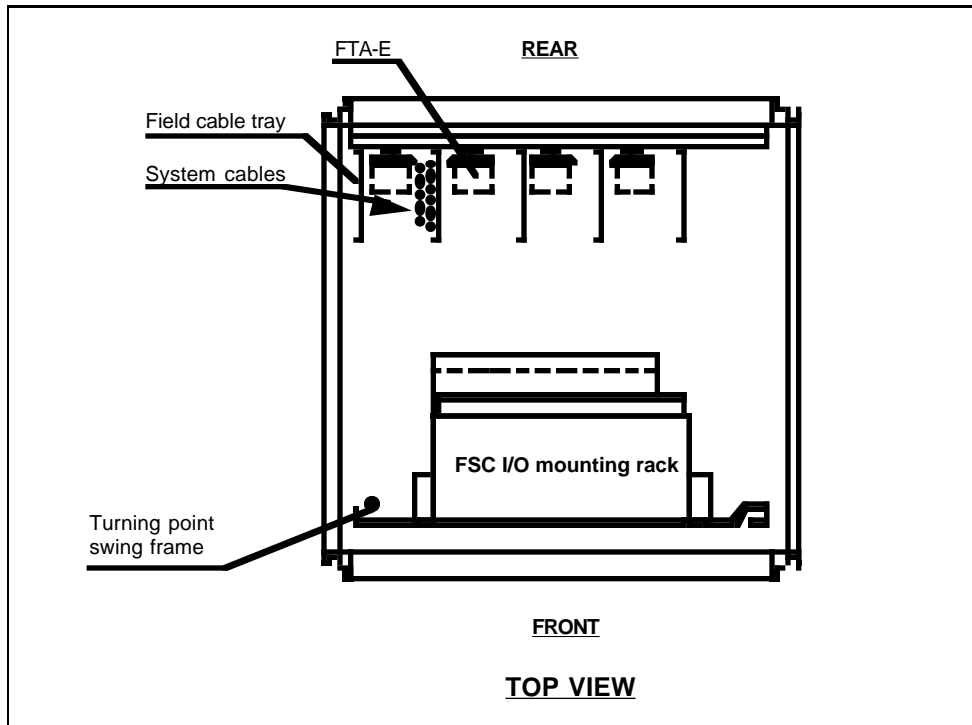

Continued on next page

1.3 Move Preparation, Continued

Cabinet entry,
continued

Figure 1-8 illustrates an FSC Safety Manager cabinet bottom configured for front and back access of the system cables with FTA-E.

Figure 1-8 – FSC-SM cabinet with front and back access (FTA-E)

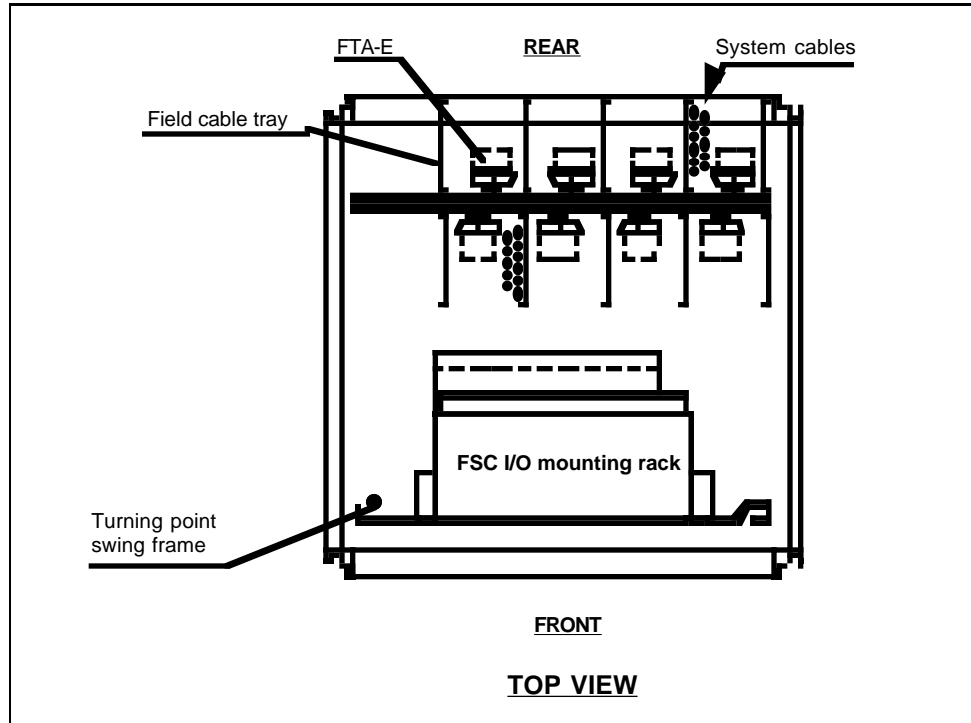

1.4 Unpacking and Placement

Unpacking

Unpack the equipment, check the shipment against the invoice, and immediately notify your Honeywell representative if any items are missing. Table 1-3 lists important considerations when unpacking the equipment.

Table 1-3 – Important unpacking considerations

IF ...	THEN ...
the FSC Safety Manager system is comprised of individual modules	the component parts are packaged in labeled boxes.
the package has visual damage	the equipment inside may also be damaged.
the package is removed and equipment has visual damage	inform the insurance company and your Honeywell representative. In any case, do not operate the equipment until confirmation from Honeywell Safety Management Systems has been obtained.

Moving

The FSC Safety Manager equipment can be moved in any one of four methods:

- fork lift,
- mobile lifter,
- roller, or
- crane.

Special consideration for each of these methods is provided in the following information.

CAUTION

When moving the FSC Safety Manager equipment:

- use lifters with a capacity of 1100 kg (2500 lbs) or greater, and
- do not tilt the cabinet more than 45° front or back to avoid damaging the doors (they are not recessed).

Continued on next page

1.4 Unpacking and Placement, Continued

Fork lift

The FSC-SM cabinet is moved by fork lift to the final location. Table 1-4 lists special considerations regarding the use of a fork lift to move the equipment.

Table 1-4 – Fork lift considerations

Number	Consideration
1	Move the equipment to the electronics room by fork lift; remove the fork lift by placing the equipment onto the lumber pieces by 10 cm (4 inches) as illustrated in Figure 1-9.
2	Tip the cabinet off the lumber and onto the floor; remove the lumber.
3	Manually move the cabinet to the exact final position.

Figure 1-9 – Placement of equipment onto lumber

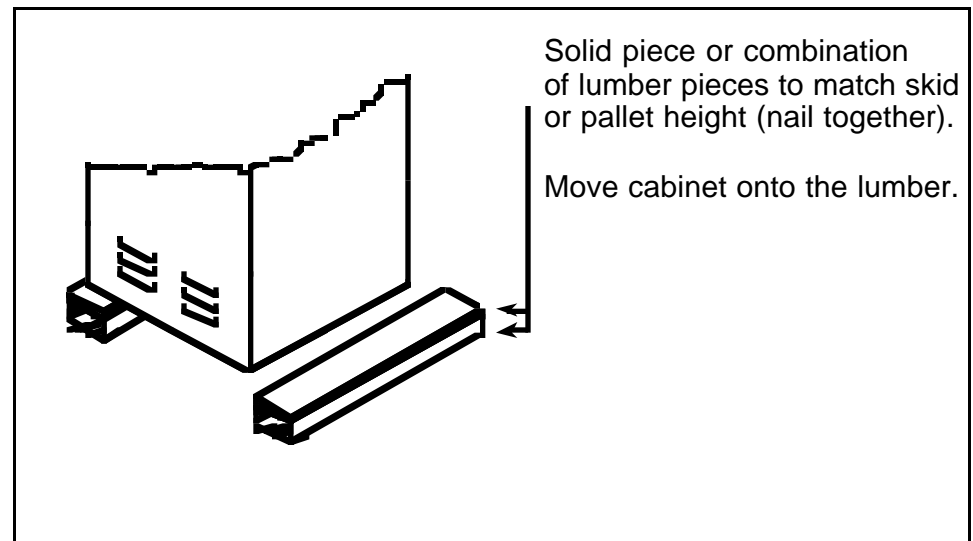

Continued on next page

1.4 Unpacking and Placement, Continued

Mobile lifter

As illustrated in Figure 1-7, the FSC Safety Manager is placed on a transport skid made from angle iron. It is then moved with a mobile lifter. Table 1-5 lists special considerations regarding the use of a mobile lifter to move the equipment.

Table 1-5 – Mobile lifter considerations

Number	Consideration
1	Tilt the equipment slightly and slide one of the angle irons used to make up a transport skid underneath the cabinet as in Figure 1-10.
2	Repeat the above step for the other angle.
3	Insert a strip of heavy cardboard between each angle iron and the equipment finish.
4	Tighten the angle irons against the cabinet by tapping slightly.
5	Insert and tighten two 12 mm (1/2-inch) minimum, threaded cross rods as in Figure 1-10 and Figure 1-11.
6	Spread the lifter forks to 80 cm (31,5-inch) centers and put them under each cross rod. Place the fork's dowels between the cross rods and the cabinet, just touching the cross rods.
7	Place wooden spacer blocks along the forks, long enough to press the cross rods against the fork dowels.
8	Position a protective plate using braces as in Figure 1-10. Be sure that the plate does not press against handles or other cabinet hardware.
9	Raise both lifter forks evenly until the equipment clears the shipping skid; pull it out of the way.
10	Wheel the equipment to the final position in the electronics room; lower it to the floor.
11	Pull out the mobile lifters. Dismantle and remove the angle iron transport skid.
12	Manually place the cabinet in the exact final position.

Continued on next page

1.4 Unpacking and Placement, Continued

Mobile lifters,
continued

Figure 1-10 – Placement using a mobile lifter

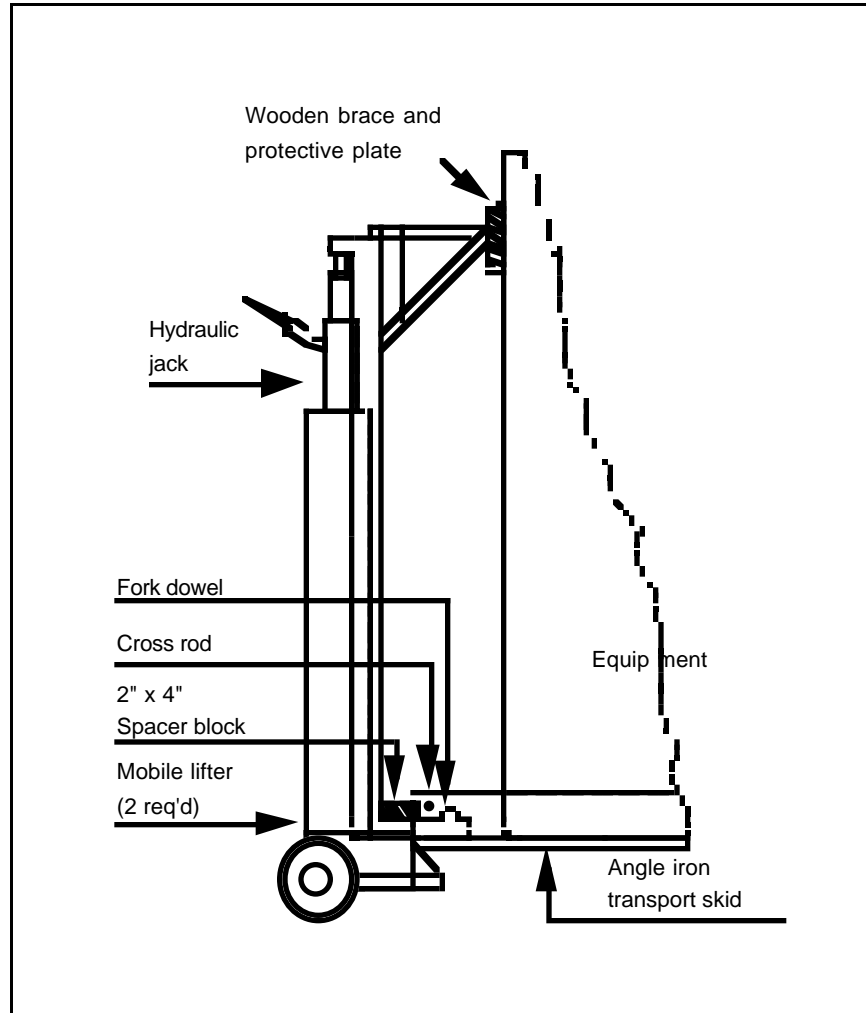

Continued on next page

1.4 Unpacking and Placement, Continued

Mobile lifters, continued

Figure 1-11 – Lifting equipment by mobile lifter of crane

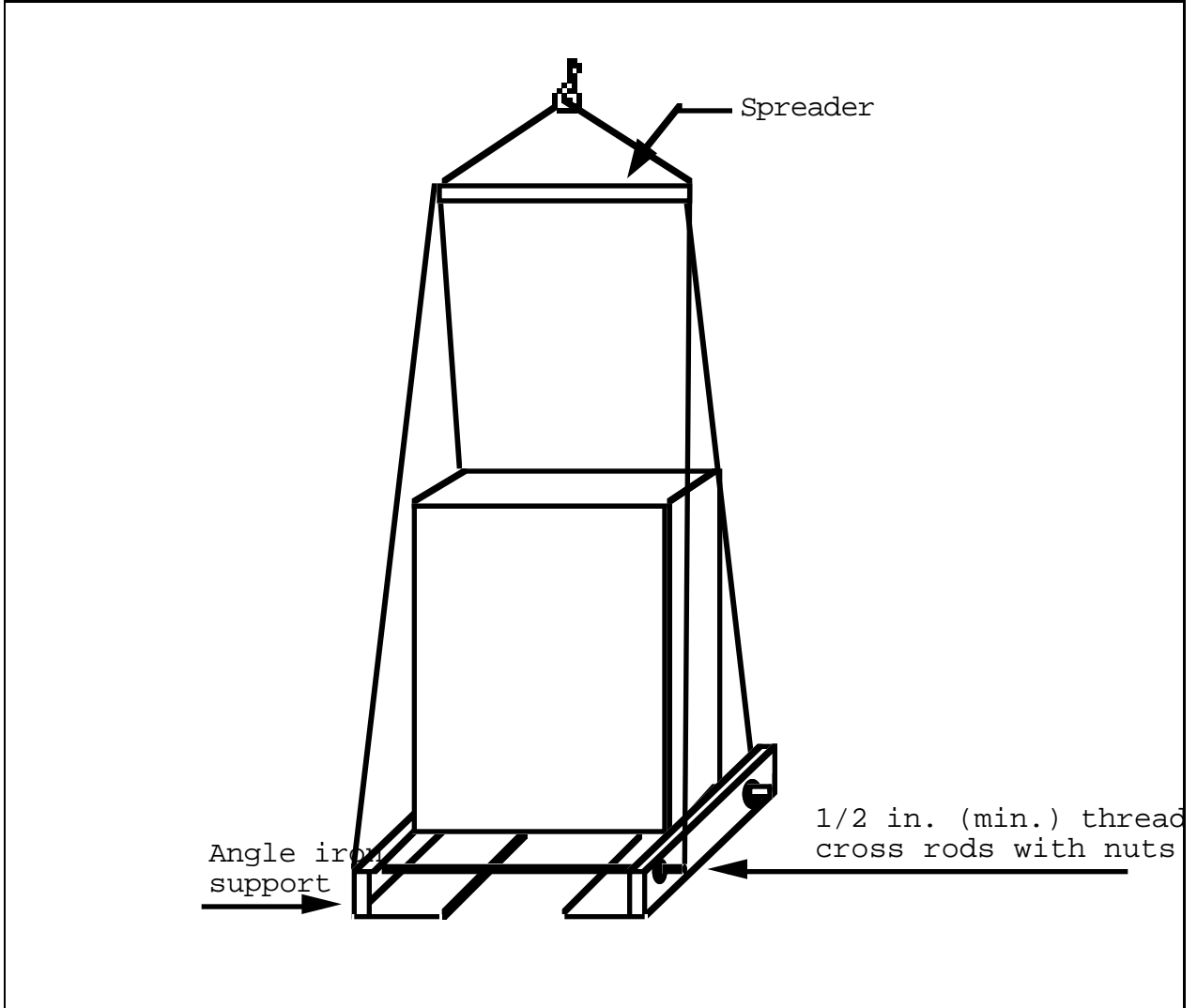

Continued on next page

1.4 Unpacking and Placement, Continued

Roller method

As illustrated in Figure 1-12, using the roller method the FSC Safety Manager is moved to its final destination by placing pipe rollers under a transport skid made of angle iron. Table 1-6 lists special considerations regarding the use of the roller method to move the equipment.

Table 1-6 – Roller method considerations

Number	Consideration
1	Use one of the previous methods to move the cabinet to a location where rollers are to be used.
2	Install the angle iron transport skid as in the mobile lifter method.
3	Place 12 mm (1/2 inch) pipes under the transport skid as in Figure 1-12. ATTENTION The load must be on the angle irons, not the cabinet.
4	Roll the cabinet to its final location. ATTENTION At least three pipes must be under the transport skid at all times.
5	When the cabinet is near the final location, tilt it and pull out the pipes, the middle one last.
6	Dismantle the transport skid and position the cabinet manually to the exact final location.

Figure 1-12 – Lifting equipment by mobile lifter of crane — part 2

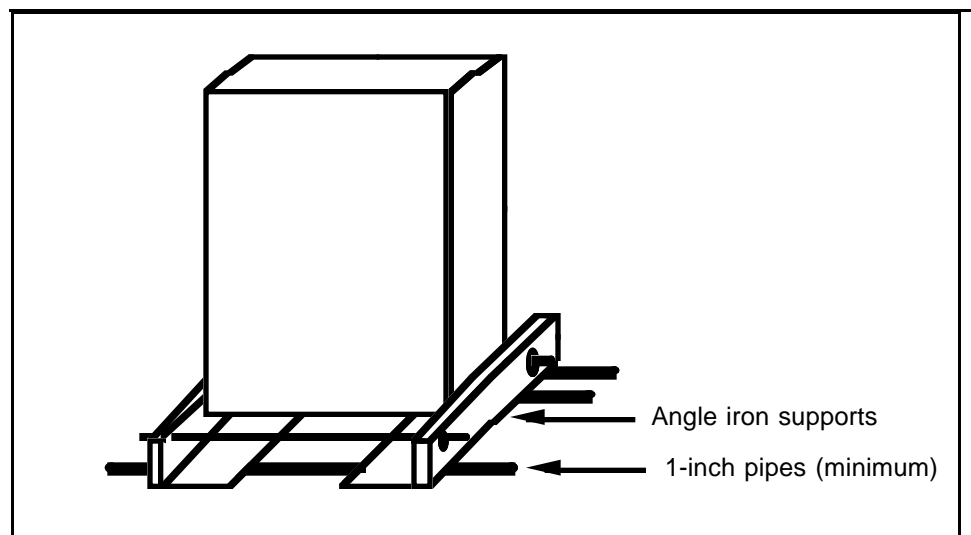

Continued on next page

1.4 Unpacking and Placement, Continued

Crane method

In this method the cabinet is lifted into place with a crane. Use either an angle iron transport skid (see Figure 1-12) or the lifting eyebolts installed on each cabinet (see Figure 1-13).

Figure 1-13 – Eyebolt crane method

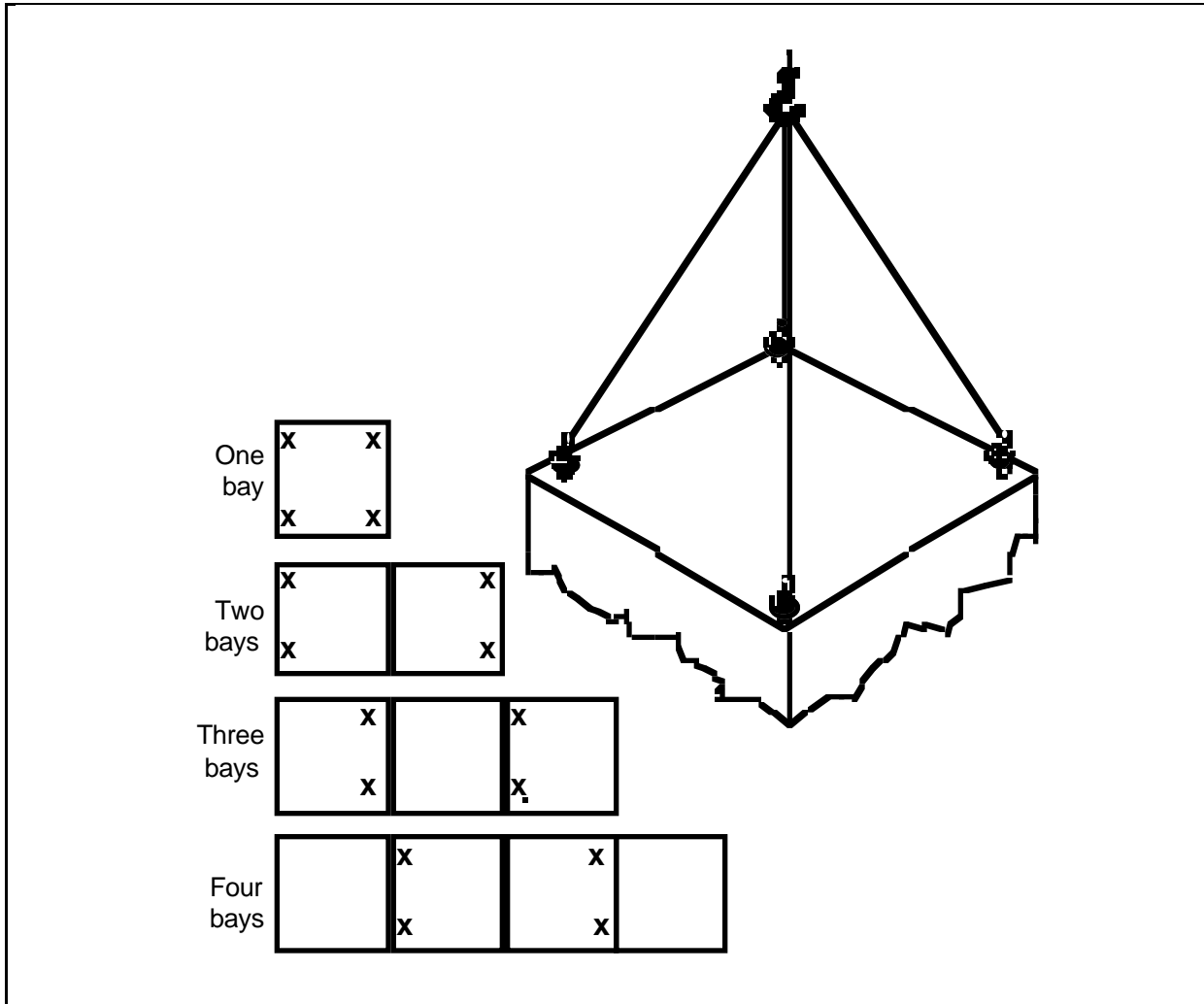

Leveling and bolt down

FSC Safety Manager cabinets do not include levelers; it may be necessary to hand-fit shims underneath the cabinet in order to make the cabinet sit solidly.

The FSC-SM cabinet has four holes in the bottom for bolting it to a floor. A partially filled cabinet should be bolted down. Cabinets that are bolted together are not easily moved and do not ordinarily require bolting down. Refer to Figure 1-2 for bolt-down dimensions.

Left blank intentionally

Section 2 – System Component Installation

2.1 Section Overview

About this section

This section provides general installation information for various components of the FSC Safety Manager (FSC-SM) system. Topics included in this section are:

Subsection	Topic	See Page
2.1	Section Overview	21
2.2	Installation Considerations	22
2.3	Cabinet Installation	23
2.4	Cabling Considerations	24
2.5	Cabling Installation	29
2.6	System Power Connections	34
2.7	System Ground Connections	36
2.8	UCN Connections	39

ATTENTION

This section describes in detail only those installation procedures and considerations specific to the FSC Safety Manager Module (FSC-SMM) and the TotalPlant Solutions (TPS) system. Installation procedures and considerations specific to the FSC components can be found in the FSC documentation.

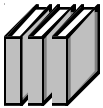

REFERENCE — For detailed information regarding

- site planning and installation, refer to SM02-550 — *TPS System Site Planning Manual* in Binder TPS 3020-1 *System Site Planning-1*.
- post-installation checkout procedures, refer to FS13-500 — *FSC Safety Manager Service Manual* in this binder.

2.2 Installation Considerations

Introduction

The FSC Safety Manager system may encompass a single cabinet or a multi-cabinet complex, or may be delivered without a cabinet.

If your FSC-SM system involves only a cabinet or cabinets, then power, ground and cabling are brought to the system and connected. The system is configured and installation is complete.

Should your FSC-SM system not include a cabinet or cabinets, the individual chassis must be mounted to a structure and power and ground supplied by a choice of methods.

Installation checklist

When installing an FSC-SM system, consider the installation checklist as shown in Table 2-1.

Table 2-1 – FSC system installation checklist

Step	Action	Done (✓)
1	Carefully review all documentation available for the equipment, paying close attention to cautionary notes.	
2	Install the FSC-SM equipment in accordance with the requirements as laid down in the Integration Guidelines for FSC System cabinets.	
3	Use technically qualified personnel to service the FSC-SM components.	

2.3 Cabinet Installation

Introduction

After placement, the cabinet or cabinet complex requires the attachment of power and ground, and cabling installation.

ATTENTION Refer to Section 1 — *FSC Safety Manager System Installation* for information regarding the warehousing, movement, unpacking and placement of the FSC Safety Manager cabinets.

2.4 Cabling Considerations

Introduction

When installing an FSC Safety Manager System, it is important to consider:

- conduit and tray shielding and spacing, and
- cable and wire classifications.

Shielding

Conduit or cable trays should be used to route the network trunk line within the plant for short distances or for several miles. The same conduit should not carry both data and power wiring because of problems created by electromagnetic interference (EMI). The choice of materials and configuration for the cable conduit can determine the degree of protection from this interference.

Table 2-2, showing raceway shielding, is taken from IEEE Standard 518 for the installation of electrical equipment. It compares different types of conduits and raceways for magnetic field attenuation at 60 Hz and for electrostatic attenuation at 100 kHz.

Table 2-2 – Raceway shielding

Raceway Type	Thickness mm (in.)	60 Hz Magnetic Field Attenuation		100 kHz Magnetic Field Attenuation	
		Ratio	dB	Ratio	dB
Free air		1:1	0	1:1	0
2 inch aluminum conduit	3.91 (0.154)	1.5:1	3.3	2,150:1	66.5
#16 gauge aluminum tray	1.52 (0.060)	1.6:1	4.1	15,500:1	83.9
#16 gauge aluminum tray	1.52 (0.060)	3:1	9.4	20,000:1	86.0
#16 gauge galvan. iron tray	1.52 (0.060)	3.2:1	10.0	22,000:1	86.8
2 inch IPS copper pipe	3.96 (0.156)	3.3:1	10.2	10,750:1	80.6
#16 gauge aluminum tray	1.52 (0.060)	4.2:1	11.5	29,000:1	89.3
#14 gauge aluminum tray	1.90 (0.075)	6:1	15.5	23,750:1	87.5
2 inch metallic tubing	1.65 (0.065)	6.7:1	16.5	3,350:1	70.5
2 inch rigid galvanized conduit	3.91 (0.154)	40:1	32.0	8,850:1	78.9

Continued on next page

2.4 Cabling Considerations, Continued

Spacing

It is recommended that noise creating sources (those with time varying voltage or time varying current) be separated from data signal cable. Cables with similar levels of noise susceptibility should be grouped together, and those with similar levels of noise generation should be separately grouped in trays and conduits.

IEEE 518 defines four classes of wiring that differ in signal level and noise susceptibility as provided in Table 2-3.

Table 2-3 – IEEE 518 wiring classification definitions

Class	Definition
Data 1	High noise susceptibility. Analog signals of less than 50 V and digital signals of less than 15 V.
Data 2	Medium susceptibility. Analog signals greater than 50 V, regulating signals of 50 V with currents less than 20 A; AC feeders less than 20 A.
Data 3	Low susceptibility. Switching signals greater than 50 V, analog signals of 50 V with currents less than 20 A; AC feeders less than 20 A.
Data 4	Power AC and DC busses of 0-1000 V with currents of 20-800 A.

ATTENTION Data 3 and Data 4 classes have one subclass each for applications that require special cable and spacing. Table 2-4, Table 2-5 and Table 2-6 in this section list the subclass for Data 3—listed as Data 3A; the subclass for Data 4 is listed as Data 4A. Examples of Data 3A and Data 4A subclass cables include:

- signals from communicating fields and line resistors,
- signals from shunts to regulators, and
- power greater than 1000 volts or greater than 800 amperes, or both.

Table 2-4, Table 2-5 and Table 2-6 list the recommended minimum distances between trays, trays and conduits, and conduits, respectively. The dimensions provided in the tables are between the top of one tray/conduit and the bottom of the tray/conduit above, or between sides of adjacent trays/conduits.

Trays containing Data 1 or Data 2 cables should have solid bottoms and covers to complete shielding. Ventilation slots or louvers may be used only in trays containing Data 3 cables.

Continued on next page

2.4 Cabling Considerations, Continued

Spacing, continued

Table 2-4 – Tray spacing

Cable Class	Data 1 mm (in.)	Data 2 mm (in.)	Data 3 mm (in.)	Data 3A mm (in.)	Data 4 mm (in.)	Data 4A mm (in.)
Data 1		<i>Note 2</i>	152.4 (6)	152.4 (6)	660.4 (26)	660.4 (26)
Data 2	<i>Note 2</i>		152.4 (6)	152.4 (6)	457.2 (18)	660.4 (26)
Data 3	152.4 (6)	152.4 (6)		0.0 (0)	<i>Note 1</i>	304.8 (12)
Data 3A	152.4 (6)	152.4 (6)	0.0 (0)		203.2 (8)	457.2 (18)
Data 4	660.4 (26)	457.2 (18)	<i>Note 1</i>	203.2 (8)		0.0 (0)
Data 4A	660.4 (26)	660.4 (26)	304.8 (12)	457.2 (18)	0.0 (0)	

ATTENTION Note the following considerations:

- Note 1
 - Data 3 and Data 4 cables may be run in a common tray but should be separated by a barrier. This barrier does not have to be grounded.
- Note 2
 - Data 1 and Data 2 cables may be in a common tray, provided they are separated by a grounded steel barrier.

Table 2-5 – Tray/conduit spacing

Cable Class	Data 1 mm (in.)	Data 2 mm (in.)	Data 3 mm (in.)	Data 3A mm (in.)	Data 4 mm (in.)	Data 4A mm (in.)
Data 1		25.4 (1)	101.6 (4)	101.6 (4)	457.2 (18)	457.2 (18)
Data 2	25.4 (1)		101.6 (4)	101.6 (4)	304.8 (12)	457.2 (18)
Data 3	101.6 (4)	101.6 (4)		0.0 (0)	0.0 (0)	203.2 (8)
Data 3A	101.6 (4)	101.6 (4)	0.0 (0)		152.4 (6)	304.8 (12)
Data 4	457.2 (18)	304.8 (12)	0.0 (0)	152.4 (6)		0.0 (0)
Data 4A	457.2 (18)	457.2 (18)	203.2 (8)	304.8 (12)	0.0 (0)	

Continued on next page

2.4 Cabling Considerations, Continued

Spacing, continued

Table 2-6 - Conduit spacing

Cable Class	Data 1 mm (in.)	Data 2 mm (in.)	Data 3 mm (in.)	Data 3A mm (in.)	Data 4 mm (in.)	Data 4A mm (in.)
Data 1		25.4 (1)	76.2 (3)	76.2 (3)	304.8 (12)	304.8 (12)
Data 2	25.4 (1)		76.2 (3)	76.2 (3)	228.6 (9)	304.8 (12)
Data 3	76.2 (3)	76.2 (3)		0.0 (0)	0.0 (0)	152.4 (6)
Data 3A	76.2 (3)	76.2 (3)	0.0 (0)		152.4 (6)	228.6 (9)
Data 4	304.8 (12)	228.6 (9)	0.0 (0)	152.4 (6)		0.0 (0)
Data 4A	304.8 (12)	304.8 (12)	152.4 (6)	228.6 (9)	0.0 (0)	

Cable, wire and conduit selection

Select the proper cables for each type of system connection. All Programmable Logic Controller (such as the FSC) system wires and cables can be classified into two categories:

- High level conductors
 - used to carry high voltage and/or high current,
 - typically IEEE 518 Data 2, Data 3, and Data 4 categories, and
 - include AC I/O lines; high level DC I/O lines connected to such devices as switches, relays, or solenoids; and AC power lines.
- Low level conductors
 - used to carry low voltage and/or low current,
 - typically IEEE 518 Data 1 category, and
 - include communication cables; DC I/O lines connected to solid state devices such as proximity switches or photoelectric sensors; TTL signal lines; analog signal lines; encoder signal lines; and motion control signal lines.

Continued on next page

2.4 Cabling Considerations, Continued

Cabling and wiring guidelines

Observe the guidelines presented in Table 2-7 when routing cables to the FSC Safety Manager cabinet. Pay special attention to separating data cables from power cables to avoid electrical noise problems.

Table 2-7 – Cabling guidelines

Consideration	Description
1	Maintain a 60°C (140°F), or less, ambient air temperature at the bottom of each FSC Safety Manager system.
2	Do all wiring according to IEEE Standard 518-1977.
3	Separate all AC and low-level DC wiring. See Table 2-4, Table 2-5 and Table 2-6 for the recommended minimum distances.
4	Shields of data communications cables must be terminated at both ends. Shields of analog signal cables must be terminated to ground only at the signal source. If a termination is not made, or is intermittent, noise immunity is lost.
5	Data and power cables should cross at right angles and not run in parallel for any distance.
6	Ensure that the entire communications network system is grounded to earth ground.
7	Maintain shield continuity. Ensure that shield leads are not broken.
8	Route cables around rather than through high noise areas.

2.5 Cabling Installation

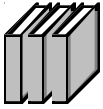

REFERENCE — For information regarding general cabling considerations, refer to Subsection 2.4 — *Cabling Considerations*.

FSC-SMM cabling

Figure 2-1 illustrates the front plate of the FSC Safety Manager Module (FSC-SMM). Connections to the UCN are made via the two UCN F-style connectors in the center of the module (A and B).

Figure 2-1 – FSC-SMM front plate

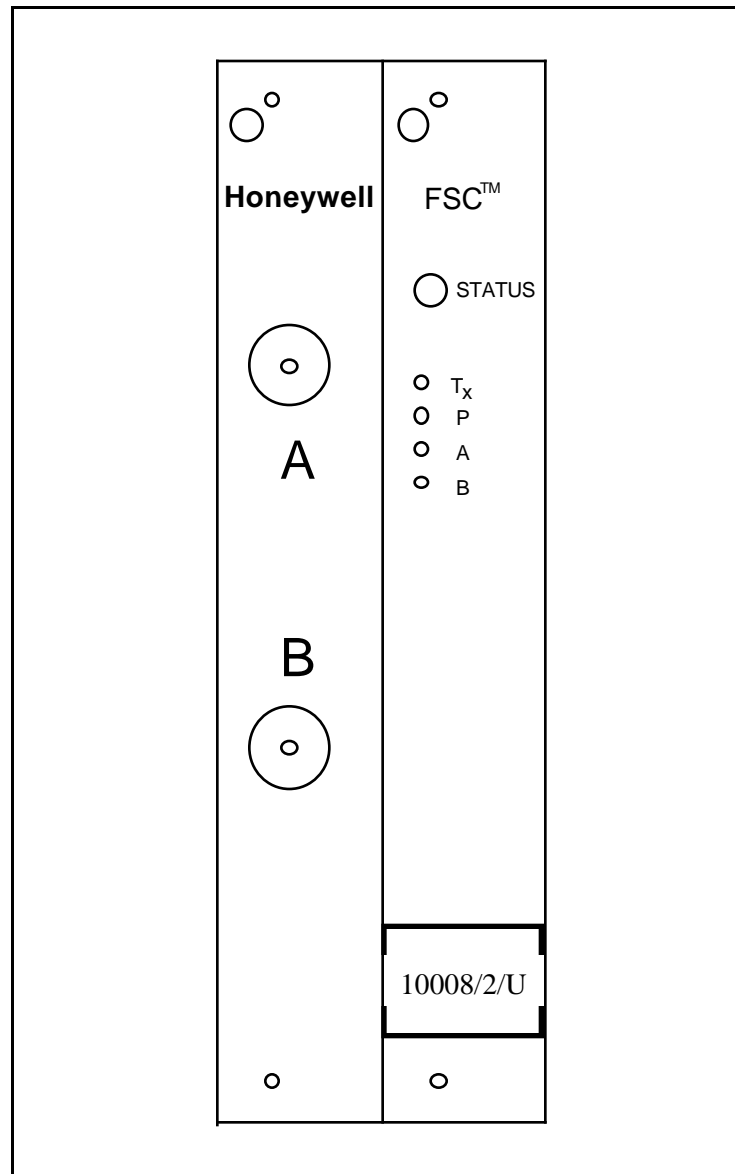

Continued on next page

2.5 Cabling Installation, Continued

FSC-SMM cabling, continued

Figure 2-2 illustrates the UCN cabling required of a redundant FSC Safety Manager system.

In this case two FSC-SMM modules are installed, one in each Central Part. RG-6 UCN drop cables are run from the drop ports on UCN A to UCN A F-style connectors of each FSC-SMM. RG-6 UCN drop cables are also run from the drop ports on UCN B to UCN B F-style connectors of each FSC-SMM.

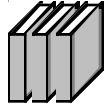

For detailed information on cabling requirements, refer to the *Integration Guidelines for FSC System Cabinets*.

Figure 2-2 – Redundant FSC-SM UCN cabling

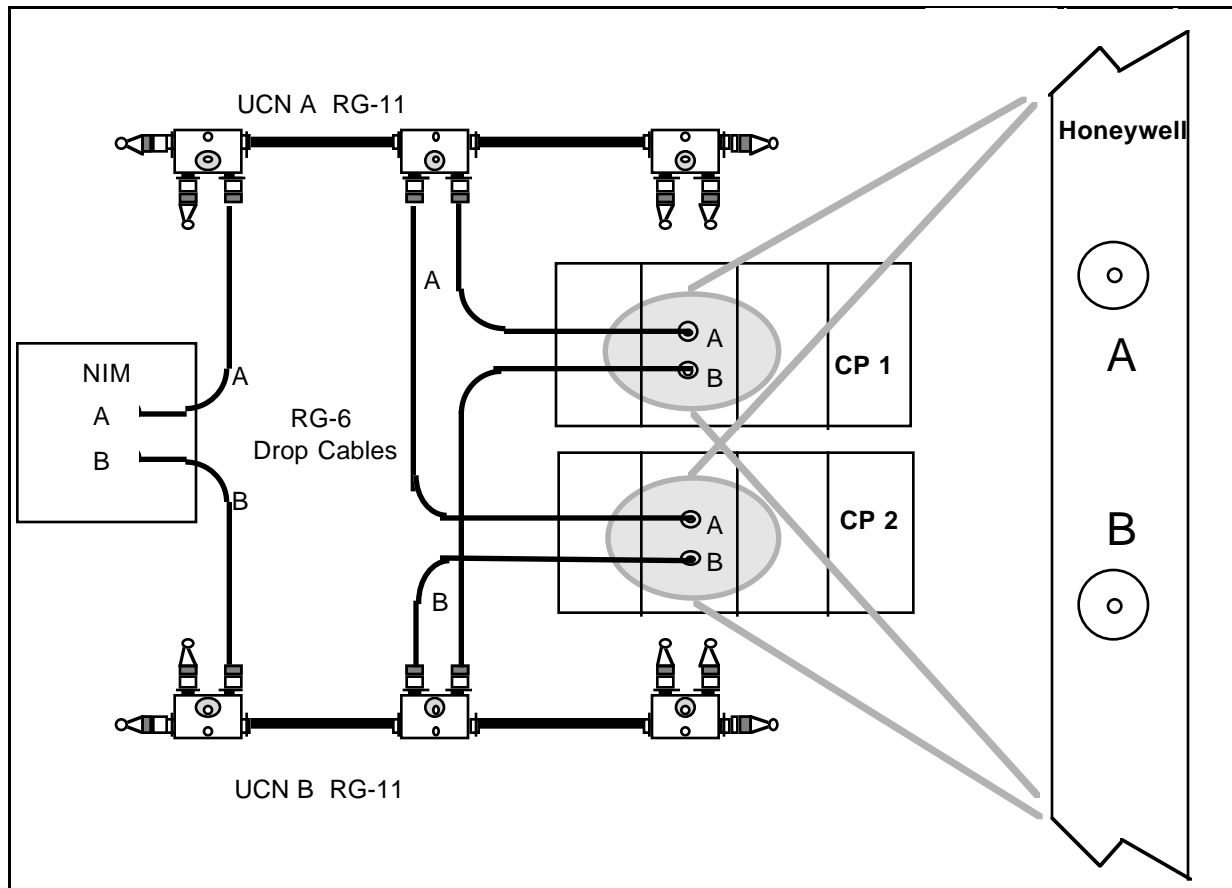

CAUTION Remove the UCN cable from the FSC-SMM port without breaking UCN cable continuity, or communication will be lost to other UCN devices.

Continued on next page

2.6 Cabling and Wiring Installation, Continued

I/O module wiring,
continued

Figure 2-4 illustrates a typical routing layout of the internal wiring between I/O modules and FTA-E via system interconnection cables (SICs).

Figure 2-4 – Typical routing layout of internal wiring between I/O modules and FTA-E via SICs

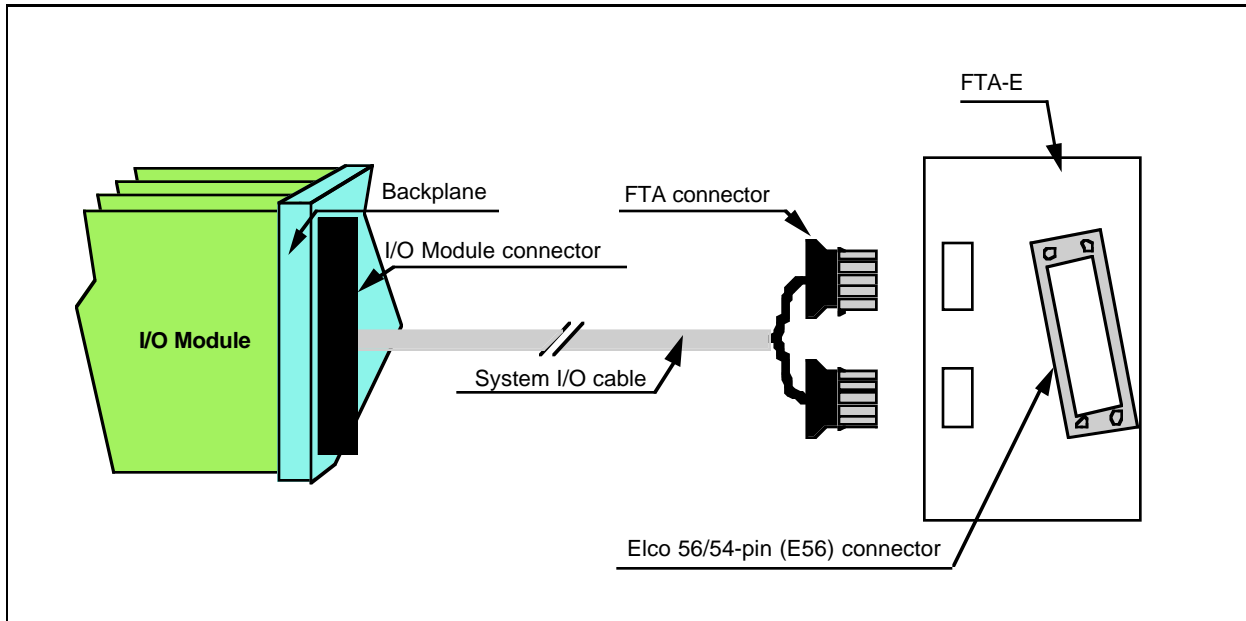

Continued on next page

2.5 Cabling Installation, Continued

Communication module cabling

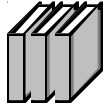

For more information on communication module cabling, refer to the *FSC Hardware Manual* and the *Integration Guidelines for FSC System Cabinets*.

FSC-DS cabling

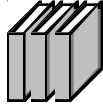

For more information on FSC-DS cabling, refer to the *FSC Hardware Manual*.

Continued on next page

2.6 System Power Connections

Cabinet power connections

Figure 2-5 illustrates a typical power connection layout for an FSC Safety Manager cabinet.

Conductors and breakers, used to supply power to the cabinet, are sized using rules in the *Integration Guidelines for FSC System Cabinets*. Refer to your site planning drawings and this figure to install power.

A cabinet will have a terminal bar at the bottom of the cabinet to connect two or more feeders.

Figure 2-5 – Typical FSC-SM cabinet power and ground connections

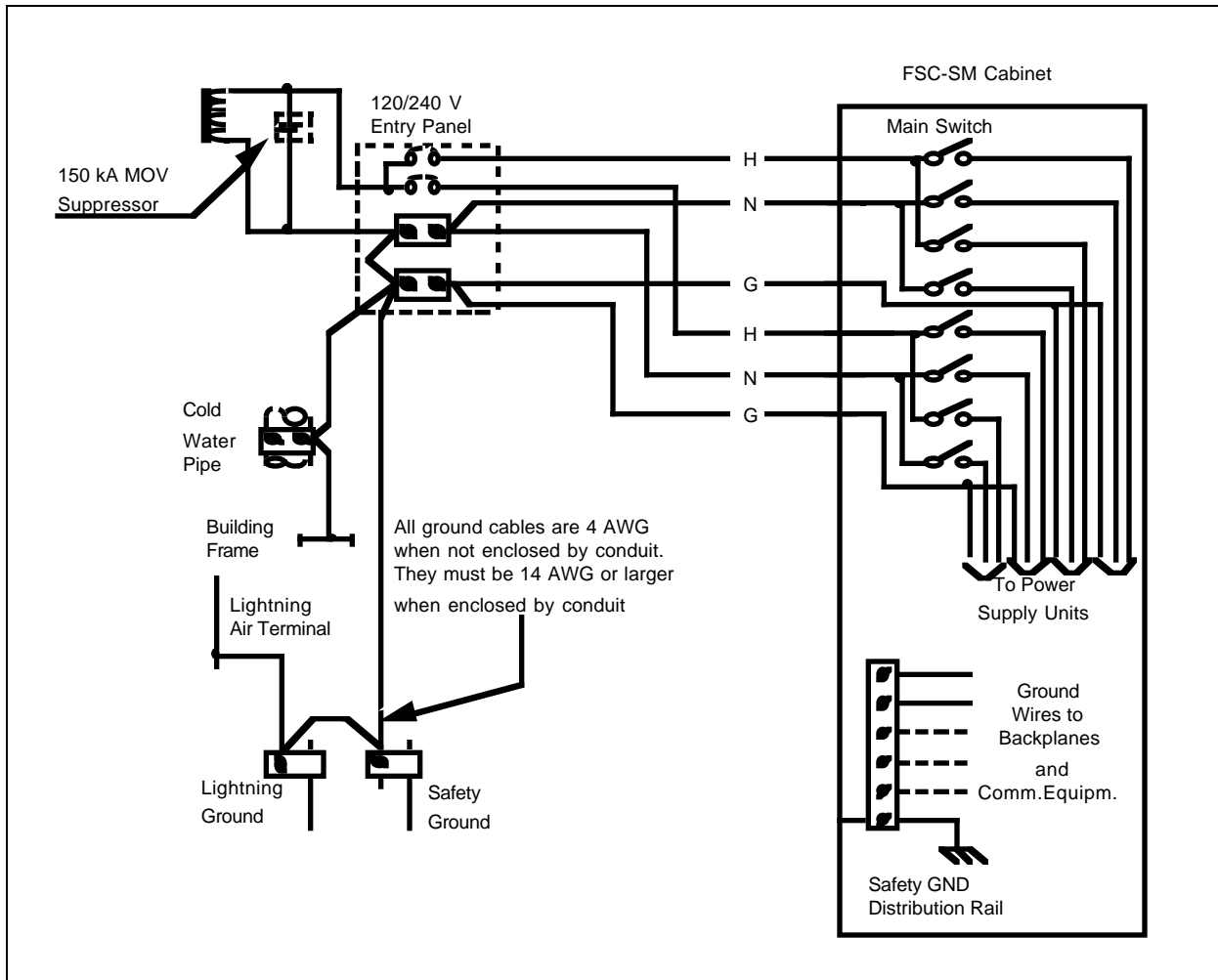

2.6 System Power Connections, Continued

Module power connections

Power is supplied to each FSC Safety Manager Module via the system bus of the Central Part.

2.7 System Ground Connections

Background

The FSC Safety Manager cabinets, backplanes, termination panels, communications equipment and field wiring must be properly grounded to ensure correct and safe operation. This subsection provides the necessary information needed to make these connections.

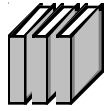

For basic information regarding the FSC's grounding requirements, refer to *Integration Guidelines for FSC System Cabinets*.

Grounding considerations

Adequate grounding is important for safety considerations and for reducing electromagnetic noise interference. All earth ground connections must be permanent and provide a continuous low impedance path to earth ground for induced noise currents and fault currents. Table 2-8 lists the steps to be performed when grounding your system.

Table 2-8 – System grounding considerations

Step	Action
1	<p>Use the system grounding techniques described in this subsection and those defined in the FSC documentation before making ground connections. Establish:</p> <ul style="list-style-type: none"> • AC safety ground by making a <ul style="list-style-type: none"> – temporary connection using the grounding terminal on front of each power supply module, and – permanent, redundant connection to safety ground attaching No. 8 AWG from ground to each card file using a crimped ring lug and 1/4" bolt. • signal ground by tying together the signal ground and safety ground at <u>one</u> and <u>only one</u> point. • shield ground by connecting one end of the shield of each field cable between an analog termination panel and analog field device.
2	Select the proper voltage (115 Vac or 230 Vac) for all configurable modules before supplying power to the system.
3	Securely fasten all cover plates in order to maintain system integrity and to ensure system grounding.

Continued on next page

2.7 System Ground Connections, Continued

Grounding considerations, continued

Table 2-8 – System grounding considerations (continued)

Step	Action
4	Firmly tighten all screws on FSC-SMM module front plates and Central Part coverplates.
5	Consult IEEE Standard 518-1977, the National Electric Code, and Subsections 2.4 and 2.5 of this document before wiring the system components.

Cabinet ground connections

Figure 2-5 illustrates a typical power and ground connections layout for an FSC Safety Manager cabinet.

Ground wires from all mechanical parts and every backplane in the cabinet are collected at a bus bar located at the bottom of the cabinet. This bus bar must be connected to building safety ground with a 1.67 mm (14 AWG) wire in conduit or a 5.3 mm (4 AWG) wire without conduit. Each cabinet must be connected individually to building safety ground and not daisy-chained with other cabinets or equipment.

Continued on next page

2.7 System Ground Connections, Continued

Safety ground

The FSC Safety Manager cabinet and external termination panels are properly connected to safety ground in accordance to the specifications and techniques stipulated by FSC.

The FSC Safety Manager backplanes and communication equipment are properly connected to safety ground. To insure proper operation of the FSC-SM, safety ground must be configured in accordance with the specifications and techniques stipulated by FSC.

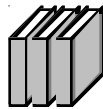

For more information on cabinet grounding, refer to the *Integration Guidelines for FSC System Cabinets*.

Shield ground

Field wiring between analog field devices for both the internal and external termination panels must be properly connected to shield (earth) ground. To insure proper communication over these links, shield ground must be configured in accordance to the specifications and techniques stipulated by FSC.

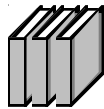

For more information on shield grounding, refer to the *Integration Guidelines for FSC System Cabinets*.

Communication equipment grounding

Communication equipment connected to the FSC Safety Manager must be grounded in accordance to the specifications and techniques stipulated by FSC.

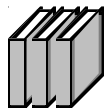

For more information on communication equipment grounding, refer to the *Integration Guidelines for FSC System Cabinets*.

2.8 UCN Connections

Node address selection

Unlike other UCN devices, the UCN node address is configured via the FSC-DS and becomes slot-dependent.

UCN installation

The installation procedure and cabling information can be found in the *UCN Site Planning and Installation* manual in the *UCN Site Planning and Installation* binder.

Figure 2-6 illustrates a typical UCN installation. Connection of the UCN system is made at the front panel of the FSC Safety Manager Module.

ATTENTION For detailed information regarding the connection of the UCN to the FSC Safety Manager, refer to Subsection 2.5 — *Wiring and Cabling Installation* under the topic, “FSC-SMM Cabling,” in this document.

Continued on next page

2.8 UCN Connections, Continued

UCN installation, continued

Figure 2-6 – Connection of the UCN

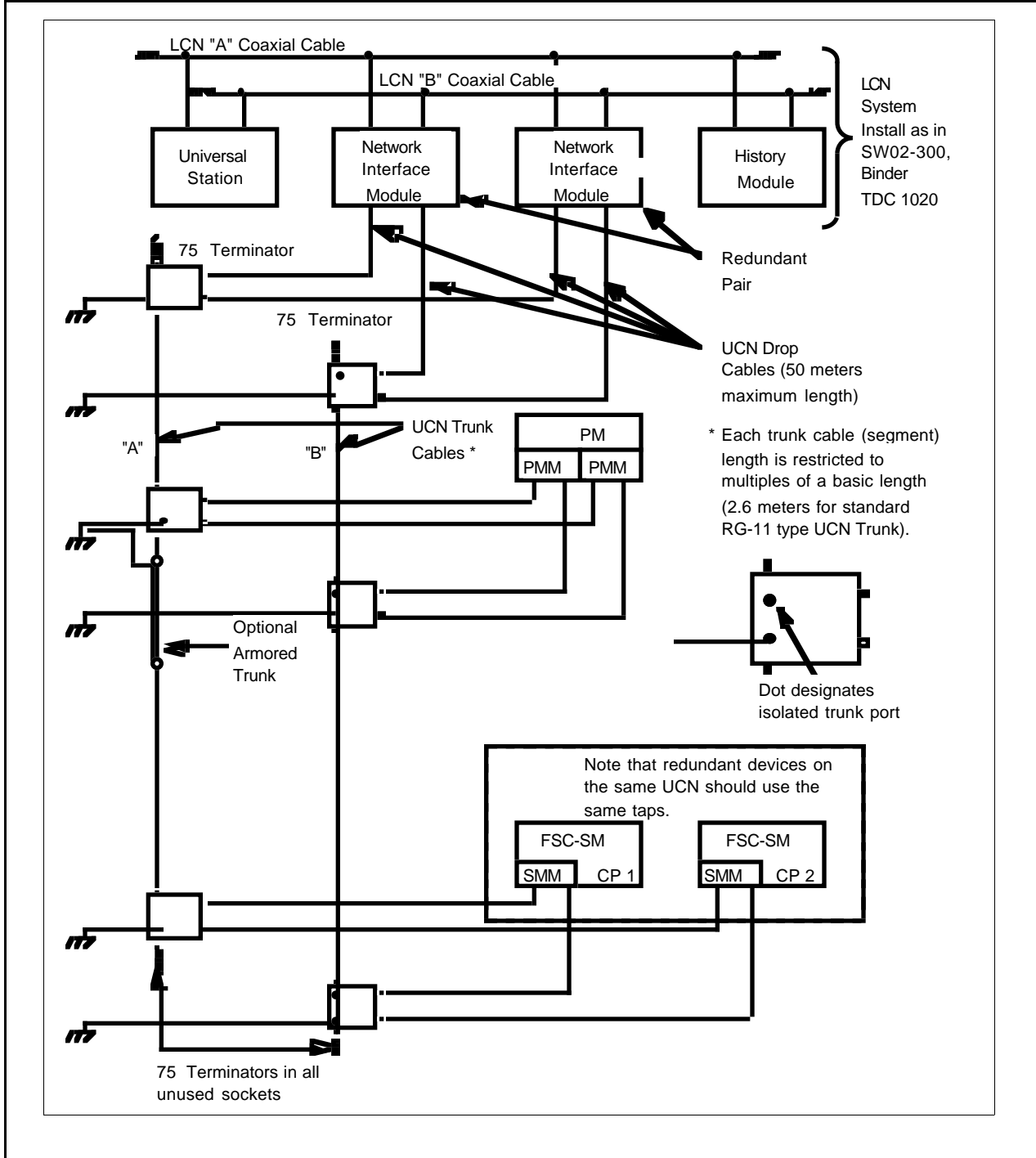

Continued on next page

2.8 UCN Connections, Continued

Trunk cable connection

Connection of the UCN trunk lines are made at the front panel of the FSC Safety Manager Module. Refer to Figure 2-2 for more details. Use the procedure that is found in the *TPS System Site Planning* manual as the installation guide.

Left blank intentionally

Section 3 – System Component Configuration

3.1 Section Overview

About this section

This section provides general installation information for various components of the FSC Safety Manager (FSC-SM) system. Topics included in this section are:

Subsection	Topic	See Page
3.1	Section Overview	43
3.2	System Configuration Overview	44
3.3	Module Configuration	45

ATTENTION

This section describes in detail only those installation procedures and considerations specific to the FSC Safety Manager Module (FSC-SMM) and the TotalPlant Solution (TPS) system. Installation procedures and considerations specific to the FSC components can be found in the FSC documentation.

3.2 System Configuration Overview

Introduction

The FSC Safety Manager (FSC-SM) system consists of a redundant Fail Safe Control (FSC) system outfitted with a redundant pair of FSC Safety Manager Modules (FSC-SMMs).

Each FSC Central Part contains a central processor unit (CPU), watchdog (WD) and communication modules (COM). Each Central Part has its own dedicated I/O modules and/or shared I/O modules.

Redundant FSC-SMM modules

The FSC-SM is configured for redundant operation. There can only be one FSC-SMM in each Central Part.

In this configuration, each FSC-SMM is independently connected to the UCN. One of the two will function as the primary, carrying out all UCN to FSC-SM communication and data transfer operations. The other FSC-SMM functions as the secondary or backup link between the UCN and FSC. Database synchronization and status and control transfers between the Primary and Secondary take place over the UCN.

3.3 Module Configuration

Introduction

The FSC Safety Manager is configured using the FSC Development System (FSC-DS) software. The starting point for all configuration operations is the *Configure FSC system* option from the FSC-DS main menu. There are basically three configuration levels:

- General FSC system configuration,
 - Central Part module configuration, and
 - I/O module configuration.
-

General FSC system configuration

Using the FSC-DS program, the user can configure a number of general system settings such as:

- requirement class,
- FSC system type specification,
- process safety time,
- number of cabinets, and
- number of racks.

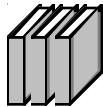

For detailed information on FSC-DS and on configuring the FSC system, refer to the *FSC Software Manual*.

Central Parts

The Central Parts can only function correctly if they are properly configured, which can be done using the FSC-DS software. A Central Part (CP) includes several standard items such as the redundant power supplies, the watchdog module and the central processing unit (CPU). It also has a number of free slots in which can be installed:

- communication modules (such as the FSC-SMM),
- diagnostic and battery module (DBM), and
- several vertical bus drivers (VBDs).

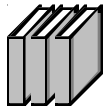

For detailed information on Central Part requirements and configuration, refer to the *FSC Hardware Manual* and the *FSC Software Manual* (which is also the user manual for FSC-DS).

Continued on next page

3.3 Module Configuration, Continued

I/O modules

The allocation of I/O modules within an FSC system and their configuration requirements depend on the safety application and on the FSC system configuration. Use the FSC-DS software to allocate I/O modules and to enter their safety relation values.

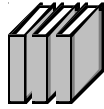

For detailed information on I/O module requirements and configuration, refer to the *FSC Hardware Manual* and the *FSC Software Manual* (which is also the user manual for FSC-DS).

Section 4 – Configuration

4.1 Section Overview

About this section

This section provides general information for various software configuration procedures for the FSC Safety Manager (FSC-SM) system. Topics included in this section are:

Subsection	Topic	See Page
4.1	Section Overview	47
4.2	FSC-DS Configuration	48
4.3	US Configuration	49

Introduction

There are three main areas which need to be configured to properly use the FSC Safety Manager within the TotalPlant Solution (TPS) system. These are the following:

- FSC Functional Logic Diagrams (FLDs) programming,
 - FSC-DS software configuration of the FSC-SM, and
 - Universal Station (US) configuration for FSC-SMM points.
-

Preconfiguration assumptions

This section assumes the following steps have been completed:

- The FSC-DS hardware (i.e. cabling) has been properly installed and connected.

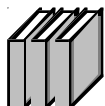

Refer to the wiring section of this manual.

- The FSC-DS software has been successfully loaded onto the PC.

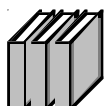

Refer to the *FSC Software Manual*.

Version needed for configuration

In order to successfully configure the FSC-SM system, you will need to be using version 400 (or higher) of the FSC software and release 510 for the TotalPlant Solution (TPS) system.

4.2 FSC-DS Configuration

Functional Logic Diagrams (FLDs) programming

Functional Logic Diagrams (FLDs) define the control program for the safety application. They are created using the FSC Development System (FSC-DS) software.

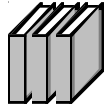

For detailed information on FSC Functional Logic Diagrams programming, refer to the *FSC Software Manual*.

FSC-DS software configuration

The FSC Development System (FSC-DS) software is used to define and configure the safety application. There are several things that need to be configured before the FSC-SM can function properly in the TPS system. The definition and configuration process consists of the following steps:

- defining the hardware configuration of the FSC-SM,
- defining the variables (which includes assigning attributes to them and allocating them to system components),
- allocating system memory for the FSC-SMM,
- assigning a UCN address to the FSC-SMM,
- assigning DCS addresses to the variables,
- compiling the application, and
- transferring the application to the FSC system (either to EPROMs or by downloading it to the system).

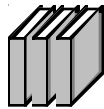

For detailed information on the software configuration of FSC-SM, refer to the *FSC Software Manual*.

4.3 US Configuration

Introduction

Once the FSC-DS software configuration has been successfully completed, you will need to use the Universal Station (US) to finish FSC-SM system configuration. This section will discuss the following US configurations:

- Universal Control Network (UCN),
- Node-specific (FSC-SM device), and
- FSC-SMM data points.

Configuration assumptions

This section covers the FSC-SM configuration process at the US. It assumes that you have completed the implementation steps for start-up and have prepared the History Module (HM) and the system for network configuration.

Table 4-1 outlines the start-up process for the TPS system. If these procedures have not been done, refer to the LCN bookset – *Implementation Startup & Reconfiguration*, binder TPS 2030-1.

Table 4-1 – Start-up and reconfiguration procedures

Step	Action	Result
1	Prepare the system for network configuration.	Universal Personality is in “this US”. Current time and date is in “this US”. The system start-up floppy is in a secure place.
2	Configure the network.	A site-specific Network Configuration File (NCF), required as input to subsequent procedures, is available.
3	Prepare the History Module.	The History Module can now be used as a source for configuration programs and data.

Continued on next page

4.3 US Configuration, Continued

UCN configuration

Once you have completed the start-up process for the US, follow the steps outlined in Table 4-2.

Table 4-2 – UCN configuration

Step	Action
1	Press the RESET button. ATTENTION The RESET button is located under the black metal panel at the top of the operator keyboard.
2	Press the LOAD button on the operator keyboard. The system will state 'Loading in progress'.
3	A prompt will appear: "N, 1, 2, 3, 4?". Press N for Network and press the <Enter> key.
4	Another prompt will appear: "OPR, UNP, X?". Press U for Universal Personality and press the <Enter> key.

Continued on next page

4.3 US Configuration, Continued

First US display

Once you have loaded the Universal Personality, the System Status display will be the first display to come up. Figure 4-1 shows this display.

Figure 4-1 – US System Status display

MAKE SELECTION										11 Sep 96 14:05:00 3		
SYS VERS: R510				SYSTEM STATUS FROM US13								
NCF VERS: 09Feb95				00:14:19:157								
CABLE A: OK				CABLE B: OK								
US01	US02	US03	US04	US05	US06	US07	US08	US09	US10	US11	US12	US13
OFF	OFF	OFF	OFF	OFF	OFF	OFF	OFF	OFF	OFF	OFF	OFF	OK
US14	US15	US16	US17	US18	US19	US20	NM21	NM22	NM23 UCN 02	NM24 JCN 02	NM25	NM26
OFF	OFF	OFF	OFF	OFF	OFF	OFF	OFF	OFF	OFF	OK	OFF	OFF
NM27	NM28	NM29	NM30	NM31	HG37	HG39	HM43	AM45	AM46	CG 49		
OFF	OFF	OFF	OFF	OFF	OFF	OFF	OK	OFF	OFF	OFF		
LOAD SELECT	LOAD CONFIG	SHOW LOADS	DE- SELECT	NTWK/HWY STATUS	NODE STATUS	STATUS DETAIL	LCN DIAG	TIME/ DATE				
LOAD ISOL	LOAD FAIL	LOAD PWR ON	SELECT AUX INFO	DUMP NODE	SHUT DOWN	LCN OVERVIEW						

Continued on next page

4.3 US Configuration, Continued

Engineering Main Menu display

In order to configure your UCN, you will need to bring up the Engineering Main Menu display. To do this, hold the [CTRL] key on the engineering keyboard and press the [HELP(M)] key. Figure 4-2 shows this display.

Once you have brought this display up, select the NETWORK INTERFACE MODULE target.

Figure 4-2 – US Engineering Main Menu display

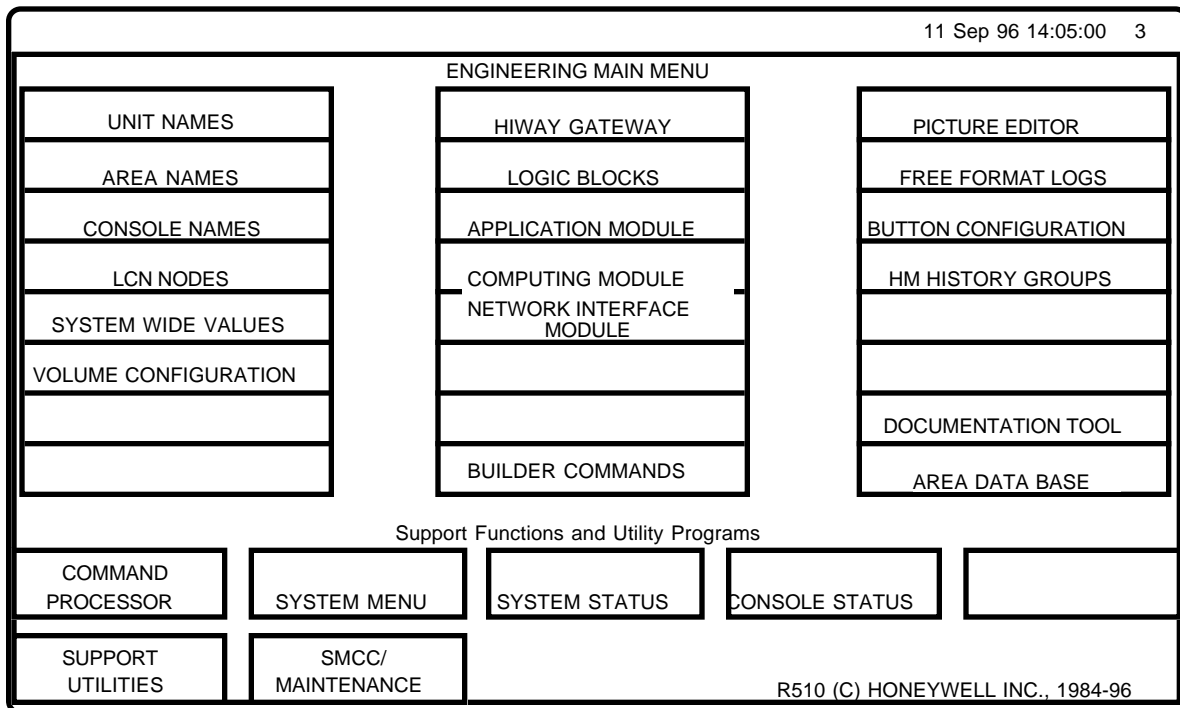

Continued on next page

4.3 US Configuration, Continued

NIM Build Type Select Menu display

The NIM Build Type Select Menu display will be the next display to come up. This display is shown in Figure 4-3. Select the UCN NODE CONFIGURATION target to configure the UCN.

Figure 4-3 – US NIM Build Type Select Menu

11 Sep 96 14:05:00 3

MENU
PAGE 01 OF 01

NIM BUILD TYPE SELECT MENU

UCN
NODE
CONFIGURATION

NODE
SPECIFIC
CONFIGURATION

PROCESS
POINT
BUILDING

LIBRARY
CONFIGURATION

F1=PED
F3=
F5=OVERWRITE
F7=RECON
F9 =WLK BACK
F11=

F2=RECALL DISP
F4=
F6=
F8=PED STATUS
F10=WRITE
F12=LOAD

UCN Node Configuration display

You should now be in the UCN Node Configuration display. Figure 4-4 shows this display. Do the steps in Table 4-3 to configure the UCN.

Table 4-3 – UCN node configuration

Step	Action
1	Enter the requested data in the given slots. All configuration information should be taken from the FSC-SM Configuration Forms you have filled out.
2	Select the FSC-SM for UCN node type and FSC for the FSC-SM platform.
3	Press the [F12 LOAD] key to load your configuration.

ATTENTION The node number you select must correspond with the node number you entered into the FSC-DS UCN configuration.

Continued on next page

4.3 US Configuration, Continued

UCN Node Configuration display,
continued

Note that the network number can be from 1 to 20. The node number can range from 1 to 63, using odd numbers only.

Figure 4-4 – US UCN Node Configuration display

		11 Sep 96 14:05:00 3	
PED >>>>>> POINT:\$NM02N13		UNIT:SY	PAGE 01 OF 01
UCN NODE CONFIGURATION			
NETWORK NUMBER	(NTWKNUM)	02	
NODE NUMBER	(NODENUM)	13	
UCN NODE TYPE	(NODETYP)	<input type="checkbox"/> NOTCONFIG <input type="checkbox"/> NIM <input type="checkbox"/> PM <input type="checkbox"/> APM <input type="checkbox"/> HPM <input type="checkbox"/> LM <input checked="" type="checkbox"/> SM	
SM PLATFORM	(SMPLTFM)	<input type="checkbox"/> TRICON <input checked="" type="checkbox"/> FSC	
NODE ASSIGNMENT	(NODEASSN)	<input checked="" type="checkbox"/> THISNIM <input type="checkbox"/> REMOTNIM	
DIGITAL COMPOSITE PV STATE TEXT			
MOVING TEXT	(MOVPVTXT)	MOVING	
BAD TEXT	(BADPVTXT)	BAD	
F1=PED F3= F5=OVERWRITE F7=RECON F9 =WLK BACK F11= F2=RECALL DISP F4= F6= F8=PED STATUS F10=WRITE F12=LOAD			

Continued on next page

4.3 US Configuration, Continued

Node-specific configuration

To configure the node-specific data, return to the NIM Build Type Select Menu by pressing the [F9 WLK BACK] key (refer back to Figure 4-3). Select the NODE SPECIFIC CONFIGURATION target. The Node-Specific Configuration display is shown in Figure 4-5.

Enter and select the desired configuration. Press the [F12 LOAD] key.

ATTENTION Make sure the network and node numbers entered for this display match those entered in the UCN Configuration display.

There is no need to configure the redundant FSC-SM device. All FSC-SM-related information will be automatically transferred to the “new” primary FSC-SM should there be a failover or switchover to the backup.

Figure 4-5 – US Node-Specific Configuration display

```
11 Sep 96 14:05:00 3
PED >>>>>> POINT:$NM02B13          UNIT:SY          UNENTERED  PAGE 01 OF 03
NODE-SPECIFIC CONFIGURATION
NETWORK NUMBER      (NTWKNUM)    02
NODE NUMBER         (NODENUM)    13
NODE TYPE           (NODETYP)    PM      APM      HPM
                   LM      SM      PM1
SM PLATFORM         (SMPLTFM)    TRICON  FSC
*****
*          *
* WARNING: IF THE POINT MIX OR THE SCA*
* RATE IS CHANGED, THEN THE NODE'S FUL*
* DATA BASE WILL BE SET TO ITS DEFAULT*
* THE DISPLAY LINES WHICH CAN CAUSE TH*
* DATA BASE TO BE DEFAULTED ARE STARRE*
* AND HAVE AN ASTERISK (*) IN COLUMN 8*
*          *
*****
F1=PED      F3=      F5=OVERWRITE  F7=RECON      F9 =WLK BACK  F11=
F2=RECALL DISP  F4=      F6=          F8=PED STATUS  F10=WRITE     F12=LOAD
```

Continued on next page

4.3 US Configuration, Continued

Process Point Building display

You must once again return to the NIM Build Type Select Menu to access the FSC-SMM data point building displays. To do this, press the [F1 PED] key.

Select the PROCESS POINT BUILDING target, once you have returned to the NIM Build Type Select Menu. Figure 4-6 shows the display which will be brought up.

Figure 4-6 – US Process Point Building display

11 Sep 96 14:05:00 3					
MENU		PAGE 01 OF 01			
NIM BUILD TYPE SELECT MENU					
NIM PROCESS POINT BUILD TYPE					
ANALOG INPUT		ANALOG OUTPUT			
DIGITAL INPUT		DIGITAL OUTPUT		DIGITAL COMPOSITE	
REGULATORY PV		REGULATORY CONTROL			
LOGIC					
FLAG		TIMER		NUMERIC	
ARRAY		DEVICE CONTROL			
PROCESS MODULE					
F1=PED	F3=	F5=OVERWRITE	F7=RECON	F9 =WLK BACK	F11=
F2=RECALL DISP	F4=	F6=	F8=PED STATUS	F10=WRITE	F12=LOAD

Continued on next page

4.3 US Configuration, Continued

Building FSC-SMM data points

This subsection takes you through the general steps for FSC-SMM data point configuration. To build FSC-SMM data points, you will need to follow the steps listed in Table 4-4.

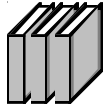

Refer to Appendix A for a page-by-page view of the configuration parameters for a given FSC-SMM point type. Also refer to *Section 4 — Data Point Detailed Description* in the *FSC Safety Manager Control Functions*, for more information.

ATTENTION Information on the definition of a specific parameter can be provided to you online by pressing the [HELP] key for the parameter you have selected.

Table 4-4 – FSC-SMM data point configuration procedure

Step	Action
1	Once you are in the Process Point Building display, select the FSC-SMM point type you wish to configure.
2	Enter and select the desired configuration scheme. Use the [PAGE FWD] button on the operator keyboard to move to the next configuration page as needed. ATTENTION Data entered should be based on the FSC-SM Configuration Forms you have filled out.
3	Press the [F12 LOAD] key to load the data in the FSC-SM database.
4	Press the [F9 WLK BACK] key to return to the Process Point Building display.
5	Repeat steps 1 to 4 for the next FSC-SMM data point type until all point types are configured.

ATTENTION FSC aliases must be configured before points can be downloaded against given aliases.

Left blank intentionally

Appendix A – FSC-SMM Data Point Configuration Displays

A.1 Overview

About this section

This appendix contains sample displays that can be viewed from the Universal Station when configuring FSC-SMM data points.

ATTENTION The highlighted selections in these displays are for example purposes only. Make your selections based on your process needs.

Topics included in this section are:

Subsection	Topic	See Page
A.1	Overview	59
A.2	Analog Input	60
A.3	Analog Output	62
A.4	Digital Input	64
A.5	Digital Output	67
A.6	Digital Composite	68
A.7	Logic	72
A.8	Flag	75
A.9	Timer	77
A.10	Numeric	79

A.2 Analog Input

Page 1 of 4

PED >>>>>> POINT:		UNIT:	UNENTERED	PAGE 01 OF 04	
11 Sep 96 14:05:00 3					
NIM- POINT ASSIGNMENT ANALOG INPUT					
TAG NAME	(NAME)	<input type="text"/>			
NODE TYPE	(NODETYP)	<input type="text"/> FM	<input type="text"/> APM	<input type="text"/> HPM	
		<input type="text"/> LM	<input type="text"/> SM		
SM PLATFORM	(SMPLTFM)	<input type="text"/> TRICON	<input type="text"/> FSC		
POINT FORM	(PNTFORM)	<input type="text"/> FULL	<input type="text"/> COMPONNT		
POINT DESCRIPTOR	(PTDESC)	<input type="text"/>			
E.U. DESCRIPTOR	(EUDESC)	<input type="text"/>			
POINT KEYWORD	(KEYWORD)	<input type="text"/>			
ASSOCIATED DISPLAY	(ASSOCDSP)	<input type="text"/>			
UNIT ID	(UNIT)	<input type="text"/>			
NETWORK NUMBER	(NTWKNUM)	<input type="text"/>			
F1=PED	F3=	F5=OVERWRITE	F7=RECON	F9 =WLK BACK	F11=TAB
F2=RECALL DISP	F4=	F6=	F8=PED STATUS	F10=WRITE	F12=LOAD

Page 2 of 4

PED >>>>>> POINT:		UNIT:	UNENTERED	PAGE 02 OF 04	
11 Sep 96 14:05:00 3					
NODE NUMBER	(NODENUM)	<input type="text"/>			
SLOT NUMBER	(SLOTNUM)	<input type="text"/>			
PRIMARY MODULE POINT ID	(PRIMMOD)	<input type="text"/>			
F1=PED	F3=	F5=OVERWRITE	F7=RECON	F9 =WLK BACK	F11=TAB
F2=RECALL DISP	F4=	F6=	F8=PED STATUS	F10=WRITE	F12=LOAD

A.2 Analog Input, Continued

Page 3 of 4

		11 Sep 96 14:05:00 3													
PED >>>>>> POINT:		UNIT:	UNENTERED PAGE 03 OF 04												
NIM- PV CONFIGURATION ANALOG INPUT															
PV RANGE HIGH	(PVEUHI)	<input type="text" value="100.0"/>													
PV RANGE LOW	(PVEULO)	<input type="text" value="0.0"/>													
PV DECIMAL FORMAT	(PVFORMAT)	<input type="text" value="D"/> <input type="text" value="D1"/> <input type="text" value="D2"/> <input type="text" value="D3"/>													
PV RANGE EXTENSION HIGH	(PVEXEUHI)	<input type="text" value="102.9"/>													
PV RANGE EXTENSION LOW	(PVEXEULO)	<input type="text" value="2.9"/>													
PV CLAMPING OPTION	(PVCLAMP)	<input type="text" value="CLAMP"/> <input type="text" value="NOCLAMP"/>													
PV SOURCE OPTION	(PVSRCOPT)	<input type="text" value="ONLYAUTO"/> <input type="text" value="ALL"/>													
PV FILTER LAG TIME	(TF)	<input type="text" value="0.0"/>													
PV TARGET VALUE	(PVTV)	<input type="text" value="-----"/>													
OVERVIEW VALUE	(OVERVAL)	<input type="text" value="25"/>													
<table style="width: 100%; font-size: small;"> <tr> <td>F1=PED</td> <td>F3=</td> <td>F5=OVERWRITE</td> <td>F7=RECON</td> <td>F9 =WLK BACK</td> <td>F11=TAB</td> </tr> <tr> <td>F2=RECALL DISP</td> <td>F4=</td> <td>F6=</td> <td>F8=PED STATUS</td> <td>F10=WRITE</td> <td>F12=LOAD</td> </tr> </table>				F1=PED	F3=	F5=OVERWRITE	F7=RECON	F9 =WLK BACK	F11=TAB	F2=RECALL DISP	F4=	F6=	F8=PED STATUS	F10=WRITE	F12=LOAD
F1=PED	F3=	F5=OVERWRITE	F7=RECON	F9 =WLK BACK	F11=TAB										
F2=RECALL DISP	F4=	F6=	F8=PED STATUS	F10=WRITE	F12=LOAD										

Page 4 of 4

		11 Sep 96 14:05:00 3													
PED >>>>>> POINT:		UNIT:	UNENTERED PAGE 04 OF 04												
NIM- ALARMING DISPLAY ANALOG INPUT															
PV ALARM DEADBAND IN %	(PVALDB)	<input type="text" value="HALF"/> <input type="text" value="ONE"/> <input type="text" value="TWO"/> <input type="text" value="THREE"/>													
		<input type="text" value="FOUR"/> <input type="text" value="FIVE"/> <input type="text" value="EU"/>													
PV HIGH TRIP POINT	(PVHITP)	<input type="text" value="----"/>													
PV LOW TRIP POINT	(PVLOTP)	<input type="text" value="----"/>													
POSITIVE PV ROC TRIP POINT	(PVROCTP)	<input type="text" value="----"/>													
NEGATIVE PV ROC TRIP POINT	(PVROCNTP)	<input type="text" value="----"/>													
BAD PV ALARM PRIORITY	(BADPVPR)	<input type="text" value="NOACTION"/> <input type="text" value="JOURNAL"/> <input type="text" value="LOW"/> <input type="text" value="HIGH"/>													
		<input type="text" value="EMERGENCY"/> <input type="text" value="PRINTER"/> <input type="text" value="INI PRINT"/>													
ALARM ENABLE STATE	(ALENBST)	<input type="text" value="ENABLE"/> <input type="text" value="DISABLE"/> <input type="text" value="INHIBIT"/>													
<table style="width: 100%; font-size: small;"> <tr> <td>F1=PED</td> <td>F3=</td> <td>F5=OVERWRITE</td> <td>F7=RECON</td> <td>F9 =WLK BACK</td> <td>F11=TAB</td> </tr> <tr> <td>F2=RECALL DISP</td> <td>F4=</td> <td>F6=</td> <td>F8=PED STATUS</td> <td>F10=WRITE</td> <td>F12=LOAD</td> </tr> </table>				F1=PED	F3=	F5=OVERWRITE	F7=RECON	F9 =WLK BACK	F11=TAB	F2=RECALL DISP	F4=	F6=	F8=PED STATUS	F10=WRITE	F12=LOAD
F1=PED	F3=	F5=OVERWRITE	F7=RECON	F9 =WLK BACK	F11=TAB										
F2=RECALL DISP	F4=	F6=	F8=PED STATUS	F10=WRITE	F12=LOAD										

A.3 Analog Output

Page 1 of 4

		11 Sep 96 14:05:00 3	
PED >>>>>> POINT:		UNIT:	UNENTERED PAGE 01 OF 04
NIM- POINT ASSIGNMENT ANALOG OUTPUT			
TAG NAME	(NAME)	<input type="text"/>	
NODE TYPE	(NODETYP)	<input type="checkbox"/> FM	<input type="checkbox"/> APM <input type="checkbox"/> HPM
		<input type="checkbox"/> LM	<input type="checkbox"/> SM
SM PLATFORM	(SMPLTFM)	<input type="checkbox"/> TRICON	<input type="checkbox"/> FSC
POINT FORM	(PNTFORM)	<input type="checkbox"/> FULL	<input type="checkbox"/> COMPOINT
POINT DESCRIPTOR	(PTDESC)	<input type="text"/>	
E.U. DESCRIPTOR	(EUDESC)	<input type="text"/>	
POINT KEYWORD	(KEYWORD)	<input type="text"/>	
ASSOCIATED DISPLAY	(ASSOCDSP)	<input type="text"/>	
UNIT ID	(UNIT)	<input type="text"/>	
NETWORK NUMBER	(NTWKNUM)	<input type="text"/>	
F1=PED		F3=	F5=OVERWRITE
F2=RECALL DISP		F4=	F6=
		F7=RECON	F8=PED STATUS
		F9 =WLK BACK	F10=WRITE
		F11=TAB	F12=LOAD

Page 2 of 4

		11 Sep 96 14:05:00 3	
PED >>>>>> POINT:		UNIT:	UNENTERED PAGE 02 OF 04
NODE NUMBER	(NODENUM)	<input type="text"/>	
SLOT NUMBER	(SLOTNUM)	<input type="text"/>	
PRIMARY MODULE POINT ID	(PRIMMOD)	<input type="text"/>	
F1=PED		F3=	F5=OVERWRITE
F2=RECALL DISP		F4=	F6=
		F7=RECON	F8=PED STATUS
		F9 =WLK BACK	F10=WRITE
		F11=TAB	F12=LOAD

A.3 Analog Output, Continued

Page 3 of 4

		11 Sep 96 14:05:00 3			
PED >>>>>> POINT:	UNIT:	UNENTERED	PAGE 03 OF 04		
NIM- OPERATING CONFIGURATION ANALOG OUTPUT					
OUTPUT DIRECTION	(OPTDIR)	<input checked="" type="checkbox"/> DIRECT	<input type="checkbox"/> REVERSE		
OUTPUT CHARACTERIZATION	(OPCHAR)	<input checked="" type="checkbox"/> OFF	<input type="checkbox"/> ON		
F1=PED	F3=	F5=OVERWRITE	F7=RECON	F9 =WLK BACK	F11=TAB
F2=RECALL DISP	F4=	F6=	F8=PED STATUS	F10=WRITE	F12=LOAD

Page 4 of 4

		11 Sep 96 14:05:00 3			
PED >>>>>> POINT:	UNIT:	UNENTERED	PAGE 04 OF 04		
NIM- MODE CONFIGURATION ANALOG OUTPUT					
REMOTE CASCADE OPTION	(RCAOPT)	<input checked="" type="checkbox"/> NONE	<input type="checkbox"/> DDC		
NORMAL MODE	(NMODE)	<input checked="" type="checkbox"/> NONE	<input type="checkbox"/> MAN		
MODE PERMISSIVE	(MODEPERM)	<input checked="" type="checkbox"/> PERMIT	<input type="checkbox"/> NOTPERM		
F1=PED	F3=	F5=OVERWRITE	F7=RECON	F9 =WLK BACK	F11=TAB
F2=RECALL DISP	F4=	F6=	F8=PED STATUS	F10=WRITE	F12=LOAD

A.4 Digital Input

Page 1 of 4

		11 Sep 96 14:05:00 3	
PED >>>>>> POINT:		UNIT:	UNENTERED PAGE 01 OF 04
NIM- POINT ASSIGNMENT DIGITAL INPUT			
TAG NAME	(NAME)	<input style="width: 150px;" type="text"/>	
NODE TYPE	(NODETYP)	<input type="checkbox"/> FM	<input type="checkbox"/> APM <input type="checkbox"/> HPM
		<input type="checkbox"/> LM	<input type="checkbox"/> SM
SM PLATFORM	(SMPLTFM)	<input type="checkbox"/> TRICON	<input type="checkbox"/> FSC
POINT FORM	(PNTFORM)	<input type="checkbox"/> FULL	<input type="checkbox"/> COMPONNT
POINT DESCRIPTOR	(PTDESC)	<input style="width: 200px;" type="text"/>	
E.U. DESCRIPTOR	(EUDESC)	<input style="width: 80px;" type="text"/>	
POINT KEYWORD	(KEYWORD)	<input style="width: 80px;" type="text"/>	
ASSOCIATED DISPLAY	(ASSOCDSP)	<input style="width: 80px;" type="text"/>	
UNIT ID	(UNIT)	<input type="checkbox"/>	
NETWORK NUMBER	(NTWKNUM)	<input type="checkbox"/>	
F1=PED		F3=	F5=OVERWRITE
F2=RECALL DISP		F4=	F6=
		F7=RECON	F8=PED STATUS
		F9 =WLK BACK	F10=WRITE
		F11=TAB	F12=LOAD

Page 2 of 4

		11 Sep 96 14:05:00 3	
PED >>>>>> POINT:		UNIT:	UNENTERED PAGE 02 OF 04
NODE NUMBER	(NODENUM)	<input type="checkbox"/>	
SLOT NUMBER	(SLOTNUM)	<input style="width: 40px;" type="text"/>	
PRIMARY MODULE POINT ID	(PRIMMOD)	<input style="width: 150px;" type="text" value="-----"/>	
DIGITAL INPUT TYPE	(DITYPE)	<input type="checkbox"/> STATUS	
F1=PED		F3=	F5=OVERWRITE
F2=RECALL DISP		F4=	F6=
		F7=RECON	F8=PED STATUS
		F9 =WLK BACK	F10=WRITE
		F11=TAB	F12=LOAD

A.4 Digital Input, Continued

Page 3 of 4

		11 Sep 96 14:05:00 3			
PED >>>>>> POINT:		UNIT:	UNENTERED	PAGE 03 OF 04	
NIM- OPERATING CONFIGURATION DIGITAL INPUT					
STATE 1 DESCRIPTOR	(STATETXT(1))	<input type="text" value="ON"/>			
STATE 0 DESCRIPTOR	(STATETXT(0))	<input type="text" value="OFF"/>			
STATE 1 BOX COLOR	(BOXCLR(1))	<input type="text" value="RED"/>	<input type="text" value="GREEN"/>	<input type="text" value="WHITE"/>	<input type="text" value="BLACK"/>
		<input type="text" value="CYAN"/>	<input type="text" value="YELLOW"/>	<input type="text" value="BLUE"/>	<input type="text" value="MAGENTA"/>
STATE 0 BOX COLOR	(BOXCLR(0))	<input type="text" value="RED"/>	<input type="text" value="GREEN"/>	<input type="text" value="WHITE"/>	<input type="text" value="BLACK"/>
		<input type="text" value="CYAN"/>	<input type="text" value="YELLOW"/>	<input type="text" value="BLUE"/>	<input type="text" value="MAGENTA"/>
INPUT DIRECTION	(INPTDIR)	<input type="text" value="DIRECT"/>		<input type="text" value="REVERSE"/>	
PV SOURCE OPTION	(PVSRCOPT)	<input type="text" value="ONLYAUTO"/>		<input type="text" value="ALL"/>	
F1=PED		F3=	F5=OVERWRITE	F7=RECON	F9 =WLK BACK
F2=RECALL DISP		F4=	F6=	F8=PED STATUS	F10=WRITE
					F11=TAB
					F12=LOAD

A.4 Digital Input, Continued

Page 4 of 4

		11 Sep 96 14:05:00 3			
PED >>>>>> POINT:	UNIT:	UNENTERED	PAGE 04 OF 04		
NIM- ALARMING DISPLAY DIGITAL INPUT					
ALARMING OPTION	(ALMOPT)	<input checked="" type="checkbox"/> NONE	<input type="checkbox"/> OFFNORMI <input type="checkbox"/> CHNGOEST		
EVENT REPORT OPTION	(EVTOPT)	<input type="checkbox"/> NONE <input type="checkbox"/> EIP	<input checked="" type="checkbox"/> SOE <input type="checkbox"/> EIP SOE		
F1=PED	F3=	F5=OVERWRITE	F7=RECON	F9 =WLK BACK	F11=TAB
F2=RECALL DISP	F4=	F6=	F8=PED STATUS	F10=WRITE	F12=LOAD

ATTENTION SOE must be chosen for points to be collected by FSC DISOE. This is how DISOE points are configured. This differs from other FSC SOE blocks (1-14).

The SOE block number is transparent at this point and data points fall into an SOE block based on which block number (15 or 16) was configured for this FSC-SM's UCN node address.

A.5 Digital Output

Page 1 of 2

		11 Sep 96 14:05:00 3	
PED >>>>>> POINT:		UNIT:	UNENTERED PAGE 01 OF 02
NIM- POINT ASSIGNMENT DIGITAL OUTPUT			
TAG NAME	(NAME)	<input type="text"/>	
NODE TYPE	(NODETYP)	<input type="checkbox"/> FM	<input type="checkbox"/> APM <input type="checkbox"/> HPM
		<input type="checkbox"/> LM	<input type="checkbox"/> SM
SM PLATFORM	(SMPLTFM)	<input type="checkbox"/> TRICON	<input type="checkbox"/> FSC
POINT FORM	(PNTFORM)	<input type="checkbox"/> FULL	<input type="checkbox"/> COMPONNT
POINT DESCRIPTOR	(PTDESC)	<input type="text"/>	
E.U. DESCRIPTOR	(EUDESC)	<input type="text"/>	
POINT KEYWORD	(KEYWORD)	<input type="text"/>	
ASSOCIATED DISPLAY	(ASSOCDSP)	<input type="text"/>	
UNIT ID	(UNIT)	<input type="checkbox"/>	
NETWORK NUMBER	(NTWKNUM)	<input type="checkbox"/>	
F1=PED		F3=	F5=OVERWRITE
F2=RECALL DISP		F4=	F6=
		F7=RECON	F8=PED STATUS
		F9 =WLK BACK	F10=WRITE
		F11=TAB	F12=LOAD

Page 2 of 2

		11 Sep 96 14:05:00 3	
PED >>>>>> POINT:		UNIT:	UNENTERED PAGE 02 OF 02
NODE NUMBER	(NODENUM)	<input type="checkbox"/>	
SLOT NUMBER	(SLOTNUM)	<input type="text"/>	
F1=PED		F3=	F5=OVERWRITE
F2=RECALL DISP		F4=	F6=
		F7=RECON	F8=PED STATUS
		F9 =WLK BACK	F10=WRITE
		F11=TAB	F12=LOAD

A.6 Digital Composite

Page 1 of 8

		11 Sep 96 14:05:00 3			
PED >>>>>> POINT:		UNIT:	UNENTERED	PAGE 01 OF 08	
NIM- POINT ASSIGNMENT DIGITAL COMPOSITE					
TAG NAME	(NAME)	<input type="text"/>			
NODE TYPE	(NODETYP)	<input type="text"/> FM	<input type="text"/> APM	<input type="text"/> HPM	
		<input type="text"/> LM	<input type="text"/> SM		
SM PLATFORM	(SMPLTFM)	<input type="text"/> TRICON	<input type="text"/> FSC		
POINT FORM	(PNTFORM)	<input type="text"/> FULL		<input type="text"/> COMPOINT	
POINT DESCRIPTOR	(PTDESC)	<input type="text"/>			
E.U. DESCRIPTOR	(EUDESC)	<input type="text"/>			
POINT KEYWORD	(KEYWORD)	<input type="text"/>			
ASSOCIATED DISPLAY	(ASSOCDSP)	<input type="text"/>			
UNIT ID	(UNIT)	<input type="text"/>			
NETWORK NUMBER	(NTWKNUM)	<input type="text"/>			
F1=PED		F3=	F5=OVERWRITE	F7=RECON	F9 =WLK BACK
F2=RECALL DISP		F4=	F6=	F8=PED STATUS	F10=WRITE
					F11=TAB
					F12=LOAD

Page 2 of 8

		11 Sep 96 14:05:00 3			
PED >>>>>> POINT:		UNIT:	UNENTERED	PAGE 02 OF 08	
NODE NUMBER	(NODENUM)	<input type="text"/>			
SLOT NUMBER	(SLOTNUM)	<input type="text"/>			
PRIMARY MODULE POINT ID	(PRIMMOD)	<input type="text"/>			
NUMBER OF STATES	(NOSTATES)	<input type="text"/> 2	<input type="text"/> 3		
NUMBER OF INPUTS	(NODINPTS)	<input type="text"/> 0	<input type="text"/> 1	<input type="text"/> 2	
NUMBER OF OUTPUTS	(NODOPTS)	<input type="text"/> 0	<input type="text"/> 1	<input type="text"/> 2	<input type="text"/> 3
F1=PED		F3=	F5=OVERWRITE	F7=RECON	F9 =WLK BACK
F2=RECALL DISP		F4=	F6=	F8=PED STATUS	F10=WRITE
					F11=TAB
					F12=LOAD

A.6 Digital Composite, Continued

Page 3 of 8

11 Sep 96 14:05:00 3														
PED >>>>>> POINT:	UNIT: UNENTERED	PAGE 03 OF 08												
NIM- STATE CONFIGURATION DIGITAL COMPOSITE														
STATE 1 DESCRIPTOR	(STATETXT(1))	<input type="text" value="ON"/>												
STATE 0 DESCRIPTOR	(STATETXT(0))	<input type="text" value="OFF"/>												
STATE 1 BOX COLOR	(BOXCLR(1))	<input type="text" value="RED"/> <input checked="" type="text" value="GREEN"/> <input type="text" value="WHITE"/> <input type="text" value="BLACK"/>												
		<input type="text" value="CYAN"/> <input type="text" value="YELLOW"/> <input type="text" value="BLUE"/> <input type="text" value="MAGENTA"/>												
STATE 0 BOX COLOR	(BOXCLR(0))	<input type="text" value="RED"/> <input type="text" value="GREEN"/> <input type="text" value="WHITE"/> <input type="text" value="BLACK"/>												
		<input type="text" value="CYAN"/> <input checked="" type="text" value="YELLOW"/> <input type="text" value="BLUE"/> <input type="text" value="MAGENTA"/>												
MOMENTARY STATES	(MOMSTATE)	<input checked="" type="text" value="NONE"/> <input type="text" value="MOM_0"/> <input type="text" value="MOM_1"/>												
LOGIC SOURCE	(LOGICSRC)	<input type="text" value="-----"/>												
<table style="width: 100%; font-size: small;"> <tr> <td>F1=PED</td> <td>F3=</td> <td>F5=OVERWRITE</td> <td>F7=RECON</td> <td>F9 =WLK BACK</td> <td>F11=TAB</td> </tr> <tr> <td>F2=RECALL DISP</td> <td>F4=</td> <td>F6=</td> <td>F8=PED STATUS</td> <td>F10=WRITE</td> <td>F12=LOAD</td> </tr> </table>			F1=PED	F3=	F5=OVERWRITE	F7=RECON	F9 =WLK BACK	F11=TAB	F2=RECALL DISP	F4=	F6=	F8=PED STATUS	F10=WRITE	F12=LOAD
F1=PED	F3=	F5=OVERWRITE	F7=RECON	F9 =WLK BACK	F11=TAB									
F2=RECALL DISP	F4=	F6=	F8=PED STATUS	F10=WRITE	F12=LOAD									

Page 4 of 8

11 Sep 96 14:05:00 3														
PED >>>>>> POINT:	UNIT: UNENTERED	PAGE 04 OF 08												
NIM- PV/INPUT CONFIGURATION DIGITAL COMPOSITE														
INPUT CONNECTIONS -----														
INPUT	SOURCE POINT.PARAMETER DISRC(N)	DESTINATION												
1	<input type="text" value=""/>	D1												
INPUT STATE CONFIGURATION -----														
D1=ON	(D1_1)	<input checked="" type="text" value="PVSTATE1"/> <input type="text" value="PVSTATE0"/>												
PV SOURCE OPTION	(PVSRCOPT)	<input checked="" type="text" value="ONLYAUTO"/> <input type="text" value="ALL"/>												
<table style="width: 100%; font-size: small;"> <tr> <td>F1=PED</td> <td>F3=</td> <td>F5=OVERWRITE</td> <td>F7=RECON</td> <td>F9 =WLK BACK</td> <td>F11=TAB</td> </tr> <tr> <td>F2=RECALL DISP</td> <td>F4=</td> <td>F6=</td> <td>F8=PED STATUS</td> <td>F10=WRITE</td> <td>F12=LOAD</td> </tr> </table>			F1=PED	F3=	F5=OVERWRITE	F7=RECON	F9 =WLK BACK	F11=TAB	F2=RECALL DISP	F4=	F6=	F8=PED STATUS	F10=WRITE	F12=LOAD
F1=PED	F3=	F5=OVERWRITE	F7=RECON	F9 =WLK BACK	F11=TAB									
F2=RECALL DISP	F4=	F6=	F8=PED STATUS	F10=WRITE	F12=LOAD									

A.6 Digital Composite, Continued

Page 7 of 8

11 Sep 96 14:05:00 3														
PED >>>>>> POINT:	UNIT: UNENTERED	PAGE 07 OF 08												
NIM- MODE CONFIGURATION DIGITAL COMPOSITE														
NORMAL MODE ATTRIBUTE	(NMODATTR)	<input checked="" type="checkbox"/> NONE <input type="checkbox"/> OPERATOR <input type="checkbox"/> PROGRAM												
MODE PERMISSIVE	(MODEPERM)	<input checked="" type="checkbox"/> PERMIT <input type="checkbox"/> NOTPERM												
INTERLOCK BYPASS OPTION	(OROPT)	<input checked="" type="checkbox"/> OFF <input type="checkbox"/> ON												
<table style="width: 100%; font-size: small;"> <tr> <td>F1=PED</td> <td>F3=</td> <td>F5=OVERWRITE</td> <td>F7=RECON</td> <td>F9 =WLK BACK</td> <td>F11=TAB</td> </tr> <tr> <td>F2=RECALL DISP</td> <td>F4=</td> <td>F6=</td> <td>F8=PED STATUS</td> <td>F10=WRITE</td> <td>F12=LOAD</td> </tr> </table>			F1=PED	F3=	F5=OVERWRITE	F7=RECON	F9 =WLK BACK	F11=TAB	F2=RECALL DISP	F4=	F6=	F8=PED STATUS	F10=WRITE	F12=LOAD
F1=PED	F3=	F5=OVERWRITE	F7=RECON	F9 =WLK BACK	F11=TAB									
F2=RECALL DISP	F4=	F6=	F8=PED STATUS	F10=WRITE	F12=LOAD									

Page 8 of 8

11 Sep 96 14:05:00 3														
PED >>>>>> POINT:	UNIT: UNENTERED	PAGE 08 OF 08												
NIM- ALARMING DISPLAY DIGITAL COMPOSITE														
ALARMING OPTION	(ALMOPT)	<input checked="" type="checkbox"/> NONE <input type="checkbox"/> CMDDIS <input type="checkbox"/> OFFNORML												
OVERRIDE ALARM OPTION	(OVRDALOP)	<input checked="" type="checkbox"/> NONE <input type="checkbox"/> AUTO_RTN <input type="checkbox"/> CNFM_RQD												
BAD PV ALARM PRIORITY	(BADPVPR)	<input type="checkbox"/> NOACTION <input type="checkbox"/> JOURNAL <input checked="" type="checkbox"/> LOW <input type="checkbox"/> HIGH												
		<input type="checkbox"/> EMERGNCY <input type="checkbox"/> PRINTER <input type="checkbox"/> INI PRINT												
BAD CONTROL ALARM PRIORITY	(BADCTLPR)	<input type="checkbox"/> NOACTION <input type="checkbox"/> JOURNAL <input checked="" type="checkbox"/> LOW <input type="checkbox"/> HIGH												
		<input type="checkbox"/> EMERGNCY <input type="checkbox"/> PRINTER <input type="checkbox"/> INI PRINT												
EVENT REPORT OPTION	(EVTOPT)	<input type="checkbox"/> NONE <input checked="" type="checkbox"/> EIP												
EIP POINT ID	(EIPPCODE)	-----												
<table style="width: 100%; font-size: small;"> <tr> <td>F1=PED</td> <td>F3=</td> <td>F5=OVERWRITE</td> <td>F7=RECON</td> <td>F9 =WLK BACK</td> <td>F11=TAB</td> </tr> <tr> <td>F2=RECALL DISP</td> <td>F4=</td> <td>F6=</td> <td>F8=PED STATUS</td> <td>F10=WRITE</td> <td>F12=LOAD</td> </tr> </table>			F1=PED	F3=	F5=OVERWRITE	F7=RECON	F9 =WLK BACK	F11=TAB	F2=RECALL DISP	F4=	F6=	F8=PED STATUS	F10=WRITE	F12=LOAD
F1=PED	F3=	F5=OVERWRITE	F7=RECON	F9 =WLK BACK	F11=TAB									
F2=RECALL DISP	F4=	F6=	F8=PED STATUS	F10=WRITE	F12=LOAD									

A.7 Logic

Page 1 of 6

11 Sep 96 14:05:00 3

PED >>>>>> POINT: UNIT: UNENTERED PAGE 01 OF 06

NIM- POINT ASSIGNMENT LOGIC

TAG NAME (NAME)

NODE TYPE (NODETYP) FM APM HPM

LM SM

SM PLATFORM (SMPLTFM) TRICON FSC

POINT FORM (PNTFORM) FULL COMPOINT

POINT DESCRIPTOR (PTDESC)

ASSOCIATED DISPLAY (ASSOCDSP)

UNIT ID (UNIT)

NETWORK NUMBER (NTWKNUM)

NODE NUMBER (NODENUM)

SLOT NUMBER (SLOTNUM)

F1=PED F3= F5=OVERWRITE F7=RECON F9 =WLK BACK F11=TAB
F2=RECALL DISP F4= F6= F8=PED STATUS F10=WRITE F12=LOAD

Page 2 of 6

11 Sep 96 14:05:00 3

PED >>>>>> POINT: UNIT: UNENTERED PAGE 02 OF 06

PRIMARY MODULE POINT ID (PRIMMOD)

LOGIC MIX (LOGMIX)

F1=PED F3= F5=OVERWRITE F7=RECON F9 =WLK BACK F11=TAB
F2=RECALL DISP F4= F6= F8=PED STATUS F10=WRITE F12=LOAD

A.7 Logic, Continued

Page 3 of 6

11 Sep 96 14:05:00 3					
PED >>>>>> POINT:	UNIT:	UNENTERED	PAGE 03 OF 06		
NIM-INPUT CONNECTIONS					
LOGIC					
INPUT #1 CONNECTION	(LISRC(1))	<input style="width: 100%;" type="text"/>			
INPUT #2 CONNECTION	(LISRC(2))	<input style="width: 100%;" type="text"/>			
INPUT #3 CONNECTION	(LISRC(3))	<input style="width: 100%;" type="text"/>			
INPUT #4 CONNECTION	(LISRC(4))	<input style="width: 100%;" type="text"/>			
INPUT #5 CONNECTION	(LISRC(5))	<input style="width: 100%;" type="text"/>			
INPUT #6 CONNECTION	(LISRC(6))	<input style="width: 100%;" type="text"/>			
INPUT #7 CONNECTION	(LISRC(7))	<input style="width: 100%;" type="text"/>			
INPUT #8 CONNECTION	(LISRC(8))	<input style="width: 100%;" type="text"/>			
INPUT #9 CONNECTION	(LISRC(9))	<input style="width: 100%;" type="text"/>			
INPUT #10 CONNECTION	(LISRC(10))	<input style="width: 100%;" type="text"/>			
INPUT #11 CONNECTION	(LISRC(11))	<input style="width: 100%;" type="text"/>			
F1=PED	F3=	F5=OVERWRITE	F7=RECON	F9 =WLK BACK	F11=TAB
F2=RECALL DISP	F4=	F6=	F8=PED STATUS	F10=WRITE	F12=LOAD

Page 4 of 6

11 Sep 96 14:05:00 3					
PED >>>>>> POINT:	UNIT:	UNENTERED	PAGE 04 OF 06		
INPUT #12 CONNECTION	(LISRC(12))	<input style="width: 100%;" type="text"/>			
LOGIC INPUT	(LIBADOPT)	<input type="checkbox"/> OFF	<input type="checkbox"/> ON		
FAILURE HANDLING OPTION					
LOGIC FLAGS AND NUMERICS = INITIAL VALUES					
NUMERIC 1 (NN(1))	<input style="width: 50px;" type="text"/>	FLAG 7 (FL(7))	<input type="checkbox"/> OFF <input type="checkbox"/> ON		
NUMERIC 2 (NN(2))	<input style="width: 50px;" type="text"/>	FLAG 8 (FL(8))	<input type="checkbox"/> OFF <input type="checkbox"/> ON		
NUMERIC 3 (NN(3))	<input style="width: 50px;" type="text"/>	FLAG 9 (FL(9))	<input type="checkbox"/> OFF <input type="checkbox"/> ON		
NUMERIC 4 (NN(4))	<input style="width: 50px;" type="text"/>	FLAG 10 (FL(10))	<input type="checkbox"/> OFF <input type="checkbox"/> ON		
		FLAG 11 (FL(11))	<input type="checkbox"/> OFF <input type="checkbox"/> ON		
		FLAG 12 (FL(12))	<input type="checkbox"/> OFF <input type="checkbox"/> ON		
F1=PED	F3=	F5=OVERWRITE	F7=RECON	F9 =WLK BACK	F11=TAB
F2=RECALL DISP	F4=	F6=	F8=PED STATUS	F10=WRITE	F12=LOAD

A.7 Logic, Continued

Page 5 of 6

11 Sep 96 14:05:00 3															
PED >>>>> POINT:		UNIT:	UNENTERED PAGE 05 OF 06												
NIM- LOGIC OUTPUT CONNECTIONS															
LOGIC															
LOGIC	OUTPUT SOURCE LOSRC(N)	DESTINATION POINT_ID.PARAMETER LODSTN(N)	ENABLE LOENBL(N)												
1	<input type="text" value="FL1"/>	<input type="text"/>	<input type="text" value="F2"/>												
2	<input type="text" value="FL1"/>	<input type="text"/>	<input type="text" value="F2"/>												
3	<input type="text" value="FL1"/>	<input type="text"/>	<input type="text" value="F2"/>												
4	<input type="text" value="FL1"/>	<input type="text"/>	<input type="text" value="F2"/>												
<table style="width: 100%; border: none;"> <tr> <td style="width: 16%;">F1=PED</td> <td style="width: 16%;">F3=</td> <td style="width: 16%;">F5=OVERWRITE</td> <td style="width: 16%;">F7=RECON</td> <td style="width: 16%;">F9 =WLK BACK</td> <td style="width: 16%;">F11=TAB</td> </tr> <tr> <td>F2=RECALL DISP</td> <td>F4=</td> <td>F6=</td> <td>F8=PED STATUS</td> <td>F10=WRITE</td> <td>F12=LOAD</td> </tr> </table>				F1=PED	F3=	F5=OVERWRITE	F7=RECON	F9 =WLK BACK	F11=TAB	F2=RECALL DISP	F4=	F6=	F8=PED STATUS	F10=WRITE	F12=LOAD
F1=PED	F3=	F5=OVERWRITE	F7=RECON	F9 =WLK BACK	F11=TAB										
F2=RECALL DISP	F4=	F6=	F8=PED STATUS	F10=WRITE	F12=LOAD										

Page 6 of 6

11 Sep 96 14:05:00 3															
PED >>>>> POINT:		UNIT:	UNENTERED PAGE 06 OF 06												
NIM- LOGIC DESCRIPTORS															
LOGIC															
NUMBER OF DESCRIPTORS	(NODESC)	<input type="text" value="0"/>													
<table style="width: 100%; border: none;"> <tr> <td style="width: 16%;">F1=PED</td> <td style="width: 16%;">F3=</td> <td style="width: 16%;">F5=OVERWRITE</td> <td style="width: 16%;">F7=RECON</td> <td style="width: 16%;">F9 =WLK BACK</td> <td style="width: 16%;">F11=TAB</td> </tr> <tr> <td>F2=RECALL DISP</td> <td>F4=</td> <td>F6=</td> <td>F8=PED STATUS</td> <td>F10=WRITE</td> <td>F12=LOAD</td> </tr> </table>				F1=PED	F3=	F5=OVERWRITE	F7=RECON	F9 =WLK BACK	F11=TAB	F2=RECALL DISP	F4=	F6=	F8=PED STATUS	F10=WRITE	F12=LOAD
F1=PED	F3=	F5=OVERWRITE	F7=RECON	F9 =WLK BACK	F11=TAB										
F2=RECALL DISP	F4=	F6=	F8=PED STATUS	F10=WRITE	F12=LOAD										

A.8 Flag

Page 1 of 3

		11 Sep 96 14:05:00 3			
PED >>>>>> POINT:		UNIT:	UNENTERED	PAGE 01 OF 03	
NIM- POINT ASSIGNMENT					
FLAG					
TAG NAME	(NAME)	<input type="text"/>			
NODE TYPE	(NODETYP)	<input type="checkbox"/> FM	<input type="checkbox"/> APM	<input type="checkbox"/> HPM	
		<input type="checkbox"/> LM	<input type="checkbox"/> SM		
SM PLATFORM	(SMPLTFM)	<input type="checkbox"/> TRICON		<input type="checkbox"/> FSC	
POINT FORM	(PNTFORM)	<input type="checkbox"/> FULL		<input type="checkbox"/> COMPONNT	
POINT DESCRIPTOR	(PTDESC)	<input type="text"/>			
E.U. DESCRIPTOR	(EUDESC)	<input type="text"/>			
POINT KEYWORD	(KEYWORD)	<input type="text"/>			
ASSOCIATED DISPLAY	(ASSOCDSP)	<input type="text"/>			
UNIT ID	(UNIT)	<input type="checkbox"/>			
NETWORK NUMBER	(NTWKNUM)	<input type="checkbox"/>			
F1=PED	F3=	F5=OVERWRITE	F7=RECON	F9 =WLK BACK	F11=TAB
F2=RECALL DISP	F4=	F6=	F8=PED STATUS	F10=WRITE	F12=LOAD

Page 2 of 3

		11 Sep 96 14:05:00 3			
PED >>>>>> POINT:		UNIT:	UNENTERED	PAGE 02 OF 03	
NODE NUMBER	(NODENUM)	<input type="checkbox"/>			
SLOT NUMBER	(SLOTNUM)	<input type="text"/>			
PRIMARY MODULE POINT ID	(PRIMMOD)	<input type="text"/>			
F1=PED	F3=	F5=OVERWRITE	F7=RECON	F9 =WLK BACK	F11=TAB
F2=RECALL DISP	F4=	F6=	F8=PED STATUS	F10=WRITE	F12=LOAD

A.8 Flag, Continued

Page 3 of 3

11 Sep 96 14:05:00 3					
PED >>>>>> POINT:		UNIT:	UNENTERED	PAGE 03 OF 03	
NIM- OPERATING CONFIGURATION FLAG					
STATE 1 DESCRIPTOR	(STATETXT(1))	<input type="text" value="ON"/>			
STATE 0 DESCRIPTOR	(STATETXT(0))	<input type="text" value="OFF"/>			
CURRENT PV STATE	(PV)	<input type="text" value="OFF"/>			
STATE 1 BOX COLOR	(BOXCLR(1))	<input type="text" value="RED"/>	<input type="text" value="GREEN"/>	<input type="text" value="WHITE"/>	<input type="text" value="BLACK"/>
		<input type="text" value="CYAN"/>	<input type="text" value="YELLOW"/>	<input type="text" value="BLUE"/>	<input type="text" value="MAGENTA"/>
STATE 0 BOX COLOR	(BOXCLR(0))	<input type="text" value="RED"/>	<input type="text" value="GREEN"/>	<input type="text" value="WHITE"/>	<input type="text" value="BLACK"/>
		<input type="text" value="CYAN"/>	<input type="text" value="YELLOW"/>	<input type="text" value="BLUE"/>	<input type="text" value="MAGENTA"/>
INPUT DIRECTION	(INPTDIR)	<input type="text" value="DIRECT"/>	<input type="text" value="REVERSE"/>		
F1=PED		F3=	F5=OVERWRITE	F7=RECON	F9 =WLK BACK
F2=RECALL DISP		F4=	F6=	F8=PED STATUS	F10=WRITE
					F11=TAB
					F12=LOAD

A.9 Timer

Page 1 of 3

		11 Sep 96 14:05:00 3			
PED >>>>>> POINT:		UNIT:	UNENTERED	PAGE 01 OF 03	
NIM- POINT ASSIGNMENT TIMER					
TAG NAME	(NAME)	<input type="text"/>			
NODE TYPE	(NODETYP)	<input type="checkbox"/> FM	<input type="checkbox"/> APM	<input type="checkbox"/> HPM	
		<input type="checkbox"/> LM	<input type="checkbox"/> SM		
SM PLATFORM	(SMPLTFM)	<input type="checkbox"/> TRICON	<input type="checkbox"/> FSC		
POINT FORM	(PNTFORM)	<input type="checkbox"/> FULL	<input type="checkbox"/> COMPOINT		
POINT DESCRIPTOR	(PTDESC)	<input type="text"/>			
E.U. DESCRIPTOR	(EUDESC)	<input type="text"/>			
POINT KEYWORD	(KEYWORD)	<input type="text"/>			
ASSOCIATED DISPLAY	(ASSOCDSP)	<input type="text"/>			
UNIT ID	(UNIT)	<input type="checkbox"/>			
NETWORK NUMBER	(NTWKNUM)	<input type="checkbox"/>			
F1=PED	F3=	F5=OVERWRITE	F7=RECON	F9 =WLK BACK	F11=TAB
F2=RECALL DISP	F4=	F6=	F8=PED STATUS	F10=WRITE	F12=LOAD

Page 2 of 3

		11 Sep 96 14:05:00 3			
PED >>>>>> POINT:		UNIT:	UNENTERED	PAGE 02 OF 03	
NODE NUMBER	(NODENUM)	<input type="checkbox"/>			
SLOT NUMBER	(SLOTNUM)	<input type="text"/>			
PRIMARY MODULE POINT ID	(PRIMMOD)	<input type="text"/>			
F1=PED	F3=	F5=OVERWRITE	F7=RECON	F9 =WLK BACK	F11=TAB
F2=RECALL DISP	F4=	F6=	F8=PED STATUS	F10=WRITE	F12=LOAD

A.9 Timer, Continued

Page 3 of 3

11 Sep 96 14:05:00 3

PED >>>>> POINT: UNIT: UNENTERED PAGE 03 OF 03

NIM- OPERATING CONFIGURATION
TIMER

TIMER BASE PERIOD (TIMEBASE) **SECONDS** [MINUTES]

SET TIME (SP) [0]

F1=PED	F3=	F5=OVERWRITE	F7=RECON	F9 =WLK BACK	F11=TAB
F2=RECALL DISP	F4=	F6=	F8=PED STATUS	F10=WRITE	F12=LOAD

A.10 Numeric

Page 1 of 3

		11 Sep 96 14:05:00 3			
PED >>>>>> POINT:		UNIT:	UNENTERED	PAGE 01 OF 03	
NIM- POINT ASSIGNMENT NUMERIC					
TAG NAME	(NAME)	<input type="text"/>			
NODE TYPE	(NODETYP)	<input type="checkbox"/> FM	<input type="checkbox"/> APM	<input type="checkbox"/> HPM	
		<input type="checkbox"/> LM	<input type="checkbox"/> SM		
SM PLATFORM	(SMPLTFM)	<input type="checkbox"/> TRICON	<input type="checkbox"/> FSC		
POINT FORM	(PNTFORM)	<input type="checkbox"/> FULL		<input type="checkbox"/> COMPONENT	
POINT DESCRIPTOR	(PTDESC)	<input type="text"/>			
E.U. DESCRIPTOR	(EUDESC)	<input type="text"/>			
POINT KEYWORD	(KEYWORD)	<input type="text"/>			
ASSOCIATED DISPLAY	(ASSOCDSP)	<input type="text"/>			
UNIT ID	(UNIT)	<input type="text"/>			
NETWORK NUMBER	(NTWKNUM)	<input type="text"/>			
F1=PED	F3=	F5=OVERWRITE	F7=RECON	F9 =WLK BACK	F11=TAB
F2=RECALL DISP	F4=	F6=	F8=PED STATUS	F10=WRITE	F12=LOAD

Page 2 of 3

		11 Sep 96 14:05:00 3			
PED >>>>>> POINT:		UNIT:	UNENTERED	PAGE 02 OF 03	
NODE NUMBER	(NODENUM)	<input type="text"/>			
SLOT NUMBER	(SLOTNUM)	<input type="text"/>			
PRIMARY MODULE POINT ID	(PRIMMOD)	<input type="text"/>			
F1=PED	F3=	F5=OVERWRITE	F7=RECON	F9 =WLK BACK	F11=TAB
F2=RECALL DISP	F4=	F6=	F8=PED STATUS	F10=WRITE	F12=LOAD

A.10 Numeric, Continued

Page 3 of 3

		11 Sep 96 14:05:00 3			
PED >>>>>> POINT:	UNIT:	UNENTERED	PAGE 03 OF 03		
NIM- PV CONFIGURATION NUMERIC					
PV	(PV)	<input type="text" value="0.0"/>			
PV DECIMAL FORMAT	(PVFORMAT)	<input type="text" value="m"/> <input type="text" value="D1"/> <input type="text" value="D2"/> <input type="text" value="D3"/>			
F1=PED	F3=	F5=OVERWRITE	F7=RECON	F9 =WLK BACK	F11=TAB
F2=RECALL DISP	F4=	F6=	F8=PED STATUS	F10=WRITE	F12=LOAD

Index

A, B

Bold-down holes, 6
Building FSC-SMM data points, 57

C

Cabinet entry, 7, 8, 9, 10, 11, 12
Cabinet ground connections, 37
Cabinet power connections, 34
Cable conduit, 24
Cable trays, 24
Cable, wire and conduit selection, 27
Cabling
 communication module, 33
 FSC-DS, 33
 FSC-SMM, 29
 Redundant, 30
Cabling guidelines, 28
Central Parts, 45
Communication equipment grounding, 38
Communication module cabling, 33
Conduit spacing, 27

D

Data signal cable, 25

E

Engineering Main Menu display, 52

F

Field termination assembly
 FTA-E, 7
 FTA-T, 7
Fork lift, 14
FSC-DS cabling, 33
FSC-SMM cabling, 29
 Redundant, 30
FSC-SMM data points, 57, 59
Functional Logic Diagrams (FLDs), 48

G

General FSC system configuration, 45
Grounding
 cabinet connections, 37
 communication equipment, 38
 safety, 38
 shield, 38
 signal, 38
Grounding considerations, 36

H

High level conductors, 27
History Module., 49

I, J, K

I/O module wiring, 31, 32
I/O modules, 46
Installation checklist, 22

L

Low level conductors, 27

M

Main chassis
 FSC, 44
Mobile lifter, 15
Module power connections, 35
Move checklist
 Electronics room, 5
 FSC-SM cabinets, 4
Moving, 13
Moving the equipment
 crane method, 19
 fork lift, 14
 mobile lifter, 15
 roller method, 18

Index

N, O

Network configuration., *49*
NIM Build Type Select Menu display, *53*
Node-specific configuration, *55*
Noise generation, *25*
Noise susceptibility, *25*

P, Q

Power supply wiring, *31*
Process Point Building display, *56*

R

Redundant FSC-SMM modules, *44*
Relative humidity, *2*

S

Safety ground, *38*
Shield ground, *38*
Shielding, *24*
Shock, *2*
Spacing
 Conduits, *27*
 Trays, *26*
 Trays/conduits, *26*
storage ratings, *2*

System status display, *51*

T

Temperature, *2*
Test equipment, *1*
Tools, *1*
Tray spacing, *26*
Tray/conduit spacing, *26*
Trunk cable connection, *41*

U

UCN installation, *39*
UCN Node Configuration display, *53*
Universal Personality, *51*
Unpacking, *13*

V

Vibration, *2*

W, X, Y, Z

Wiring classifications, *25*
Wiring guidelines, *28*

READER COMMENTS

Honeywell IAC's Automation College welcomes your comments and suggestions to improve future editions of this and other documents.

You can communicate your thoughts to us by fax or mail using this form, or by placing a toll-free telephone call. We would like to acknowledge your comments—please include your complete name, address, and telephone number.

BY FAX: Use this form and fax to us at 1-602-313-4108.

BY TELEPHONE: In the USA, use our toll-free number 1-800-822-7673 (available in the 48 contiguous states except Arizona; in Arizona dial 1-602-313-5558).

BY MAIL: Use this form and mail to us at:

Honeywell Inc.
Industrial Automation and Control
Automation College
2820 West Kelton Lane
Phoenix, AZ 85023-3028

Title of Document: **FSC Safety Manager
Installation Guide**

Issue Date: **09/96**

Document Number: **FS20-500**

Writer: **HSMS Product Marketing**

COMMENTS: _____

RECOMMENDATIONS: _____

Name: _____ **Date:** _____

Title: _____

Company: _____

Address: _____

City: _____ **State:** _____ **ZIP:** _____

Telephone: _____ **FAX:** _____

Honeywell

Helping You Control Your World

Industrial Automation and Control

Honeywell Inc.

16404 North Black Canyon Highway

Phoenix, Arizona 85023-3033