

TDC 3000X High Performance Process Manager Specification and Technical Data

HP03-500
R500
2/96

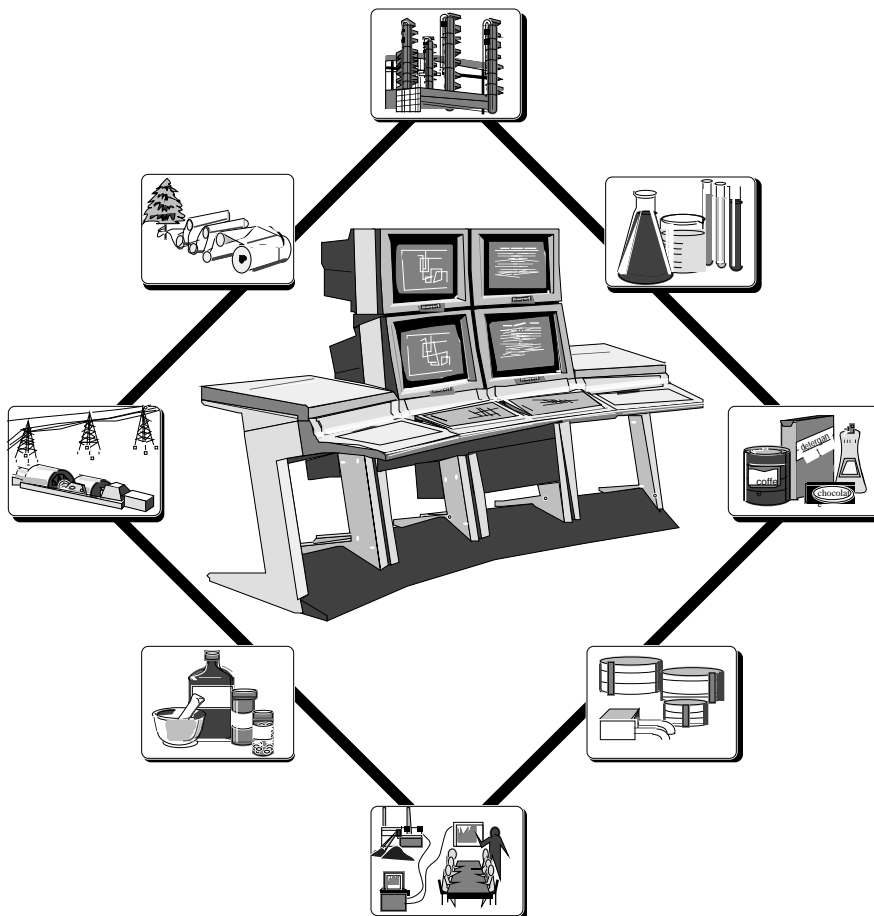

TDC 3000X High Performance Process Manager

Specification and Technical Data

TABLE OF CONTENTS	Page
Introduction	3
Advanced Features	4
Universal Control Network	4
Network Interface Module	4
Functional Description	4
Functional Overview	4
Control Functions	6
Control Implementation	11
Alarm System Functions	12
Security	12
Physical Characteristics	13
Power System	13
Card File Assemblies	13
Input/Output Functions	13
Input/Output Processors	13
Field Termination Assemblies	14
Galvanically Isolated FTAs	14
Options	15
HPM Module Redundancy	15
Power System Redundancy	15
I/O Redundancy	15
Standby Manual	15
Battery Backup	15
I/O Simulation Option	15
Remote I/O	16
Corrosion Protection Option	16
Harsh Environment	16
European Community Compliance	16
Specifications	17
HPM Environmental Conditions	17
HPM Certifications	18
CE Mark	18
HPM Standard Power Systems	19
HPM AC-Only Power Systems	20
HPMM Redundancy Option	21
I/O Link Extender (Remote I/O)	21
Model Numbers	22

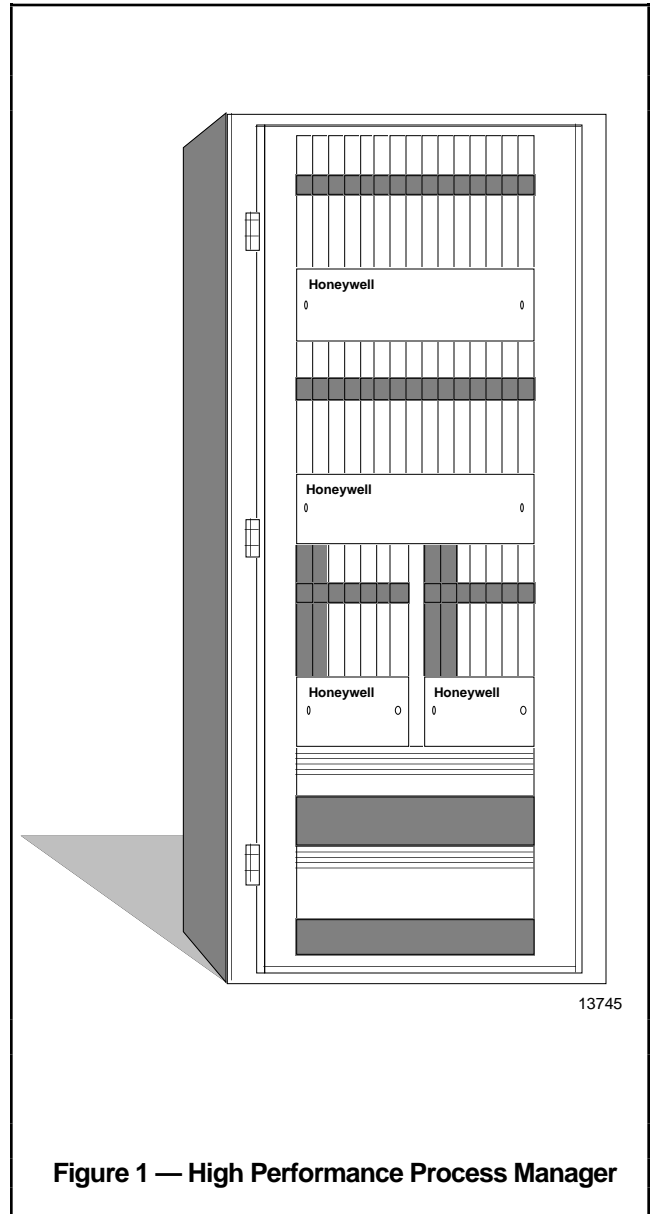

Figure 1 — High Performance Process Manager

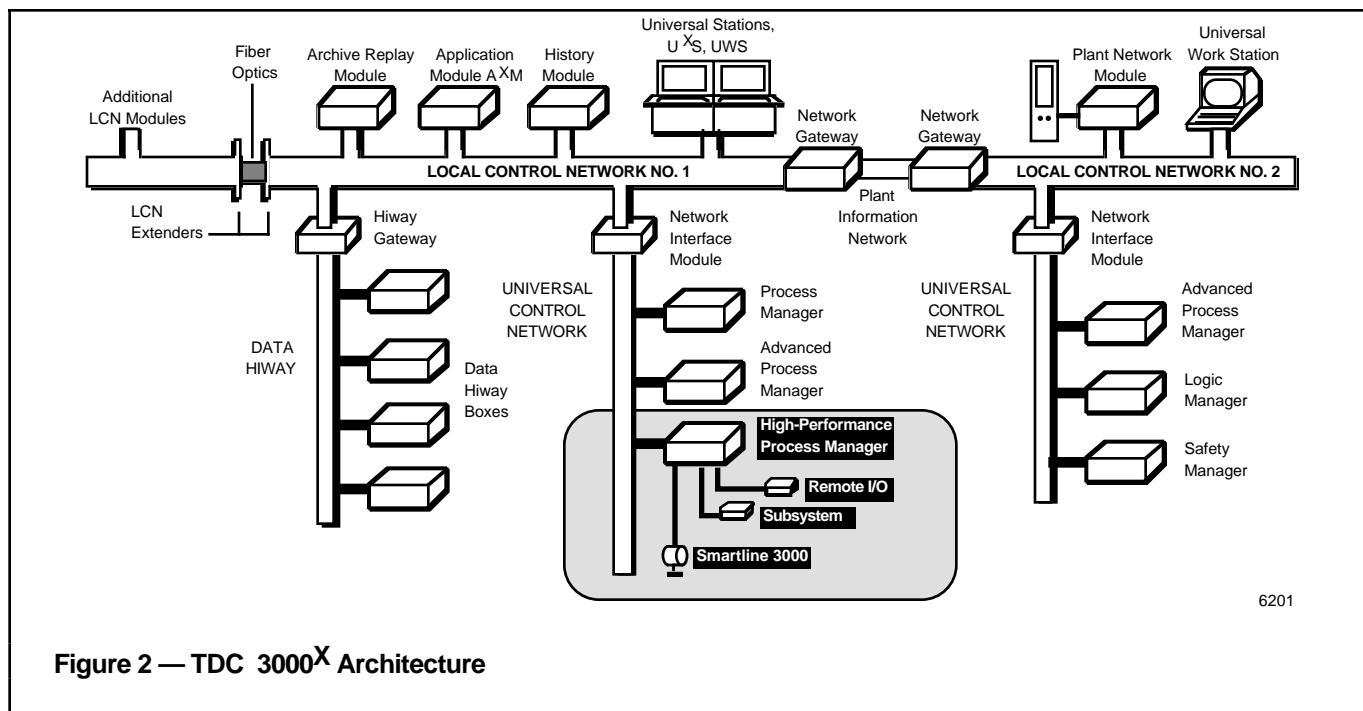

Figure 2 — TDC 3000^X Architecture

Introduction

The High Performance Process Manager (HPM) is Honeywell's leading TDC 3000^X control and data acquisition device for industrial process applications. It represents the most powerful, cost-effective controller Honeywell has offered to date.

The High Performance Process Manager represents an evolution of the highly successful Process Manager™ (PM) and Advanced Process Manager (APM). Its new dual 68040 platform offers a powerful range of capabilities that best meet today's and tomorrow's process requirements.

The HPM offers highly flexible I/O functions for both data monitoring and control. Powerful control functions, including regulatory, logic, and sequencing control, are provided for continuous, batch, sequencing, and hybrid applications.

An optimal toolbox of functions that can be configured and programmed meets the needs of data acquisition and advanced control requirements in a highly secure and performance-intensive manner. HPM's capabilities include peer-to-peer communications and compatibility with industry-standard communications protocols.

As shown in Figure 2, the High Performance Process Manager is a fully integrated member of the TDC 3000^X family. Accordingly, it is capable of:

- Performing data acquisition and control functions, including regulatory, logic, and sequential control functions, as well as peer-to-peer communications with other Universal Control Network-resident devices.
- Providing bi-directional communications to Modbus™ and Allen-Bradley compatible subsystems through a serial interface.

- Fully communicating with operators and engineers at Universal Stations, U^XSs, and Universal Work Stations. Procedures and displays are identical or similar to those used with other TDC 3000^X controllers, as well as to APM and PM point displays.
- Supporting higher level control strategies available on the Local Control Network through the Application Module and host computers.
- Using the same I/O and wiring as the PM and APM, thus providing cost-effective upward migration to existing PM and APM users.

Advanced Features

The HPM provides considerably enhanced functionality over the PM and APM. This includes:

- Improvements in the electronic and software design.
- A new, compact UCN interface.
- Five (5) times the point processing capacity of the PM and APM.
- Several new control algorithms.
- Several new CL enhancements.
- Improved I/O link performance through PV scanning.
- More user memory than both PM and APM.
- I/O Simulation capabilities.
- Choice of 7-slot or 15-slot cardfile backplanes.
- Flexible point mix change capability.

Universal Control Network

The communications channel for the High Performance Process Manager is a local area network called the Universal Control Network (UCN). Introduced to TDC 3000^X users in 1988, the UCN is the secure path for process I/O connections to the TDC 3000^X.

The UCN features a 5 megabit per second, carrier band communication system with a token bus network. It is designed to be compatible with IEEE* and ISO** standards. UCN communications are consistent with the growth and direction of evolving international standards, with appropriate Honeywell extensions for secure process control applications.

The UCN uses redundant coaxial cables and can support up to 32 redundant devices. The UCN supports peer-to-peer communication between devices on this network. This feature enables sharing information among HPMs, APMs, PMs, Safety Managers, and Logic Managers on the network, thus offering tremendous power and flexibility in implementing advanced, coordinated control strategies.

Network Interface Module

The Network Interface Module (NIM) provides the link between the Local Control Network and the Universal Control Network. Accordingly, it makes the transition from the transmission technique and protocol of the Local Control Network to the transmission technique and protocol of the Universal Control Network. The NIM provides LCN module access to data from UCN-resident devices. It supports program and database loads to the High Performance Process Manager and forwards alarms and messages from the network devices to the LCN. The NIM is also available in a redundant configuration to provide automatic, continued operation in the event of a primary failure.

LCN time and UCN time are synchronized by the NIM. The NIM broadcasts LCN time over the UCN. The HPM (as well as the APM) uses it for a number of time-driven functions, such as sequence of events reporting.

Functional Description

Functional Overview

Note: This Specification and Technical Data sheet covers the High Performance Process Manager only.

For information about HPM Input/Output Processors, which are common to the PM/APM/HPM controller family, please refer to IO03-500, Process Manager I/O Specification and Technical Data.

The High Performance Process Manager is designed to provide flexible and powerful process scanning and control capabilities. To do this, it uses an advanced multi-processor architecture with separate microprocessors dedicated to perform specific tasks. As depicted in Figure 3, the HPM consists of the **High Performance Process Manager Module (HPMM)** and the **I/O Subsystem**.

The High Performance Process Manager Module consists of a dual 68040 **High Performance Communication and Control Processor**, an **I/O Link Interface Processor**, and a **UCN Interface**. A redundant HPMM can be optionally provided.

The Communication Processor is optimized to provide high performance network communications, handling such functions as network data access and peer-to-peer communications. It also supports high-accuracy time stamping.

The Control Processor is the HPM resource dedicated to executing regulatory, logic, and sequence functions, including an excellent user programming facility. Because communication and I/O processing are performed by separate dedicated hardware, the full power of the High Performance Control Processor can be applied to control strategy implementation.

* Institute of Electrical and Electronics Engineers

** International Standards Organization

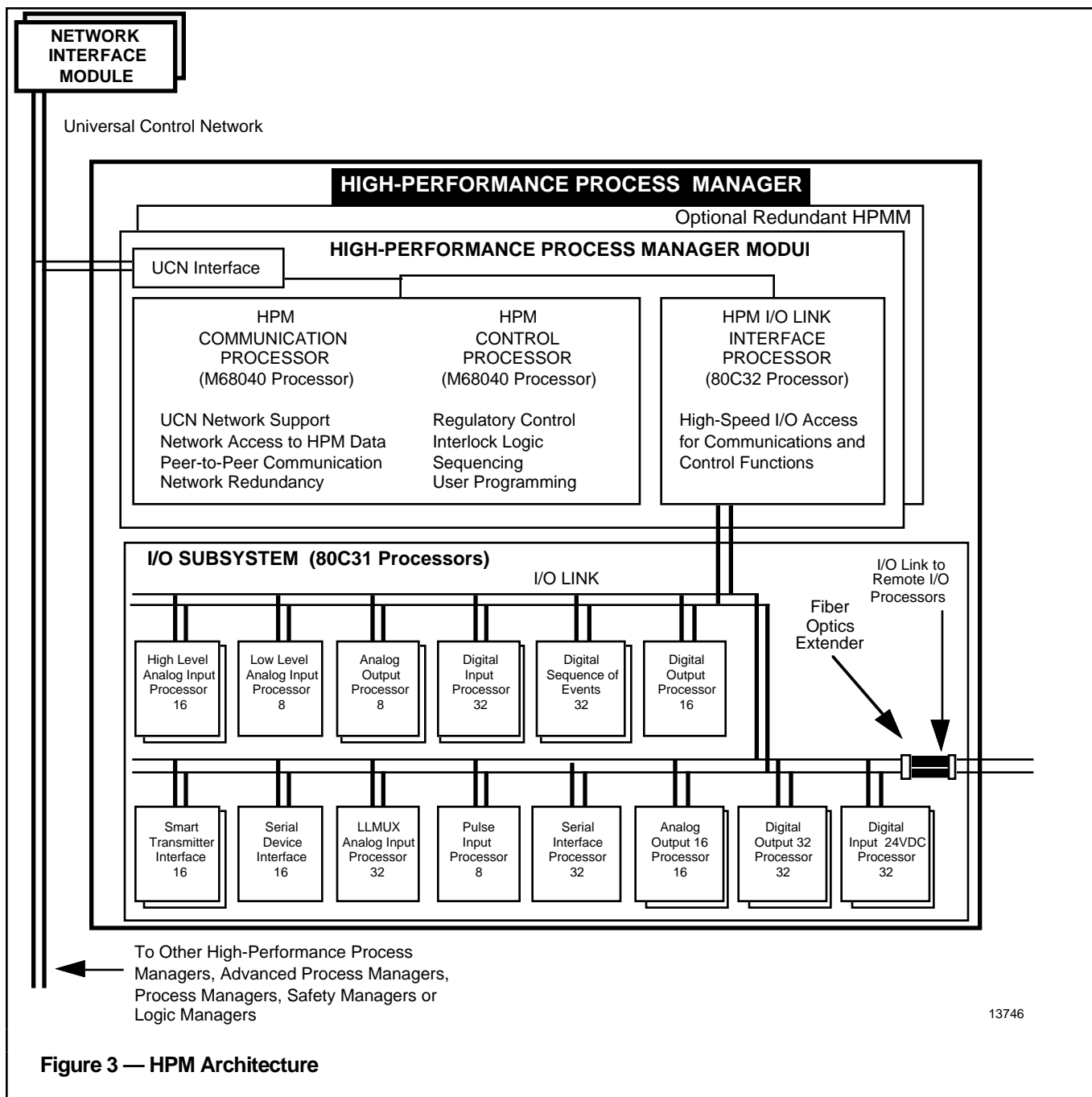

The I/O Link Interface Processor is the HPMM interface to its I/O Subsystem. The I/O Subsystem consists of the redundant I/O Link and any combination of up to 40 individual or redundant I/O Processors. These I/O Processors handle all field I/O for both data acquisition and control functions. The I/O Processors provide such

functions as engineering unit conversion and alarm limit checking, independent of the High Performance Process Manager Module.

One IOP which illustrates the advanced capabilities of the HPM I/O is the Smart Transmitter Interface. The Smart Transmitter

Interface processor provides full bi-directional communication to Honeywell smart transmitters, supporting transmitter configuration and improved data accuracy. This includes the recently introduced Multivariable transmitter capability.

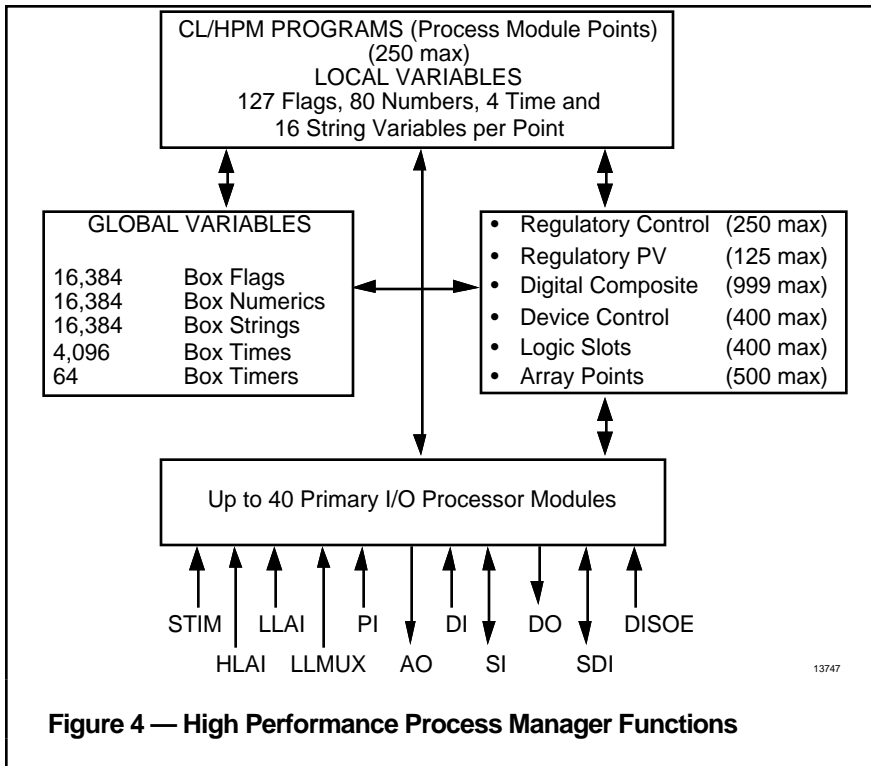

Figure 4 — High Performance Process Manager Functions

All control operations are performed within the High Performance Process Manager Module (optionally redundant), with all data acquisition and signal conditioning being performed in I/O Processors. For added control security, redundancy is available for several analog and digital I/O processing devices.

The remote I/O option allows I/O Processors to be remote-mounted up to 8 kilometers from the HPM file.

This option uses redundant fiber optic I/O Link extenders.

The process engineer has complete flexibility of choice in the assignment of point types and control strategies, within the maximum HPMM design limits. These selections are implemented using the interactive tools provided by the TDC 3000^X Universal Station, U^XS, Universal Work Station, or PC-based engineering tools.

Control Functions

The High Performance Process Manager Module (HPMM) provides a variety of control tools that can be customized to address a wide range of process automation needs.

Functions, from I/O scanning through regulatory and logic control to more advanced control, are easily implemented through the HPMM. Included are a sophisticated regulatory control algorithm set, fully integrated interlock logic functions, and an advanced process engineer-oriented Control Language (CL/HPM).

CL/HPM is an enhanced version of the Control Language implemented by Honeywell in the Process Manager and Advanced Process Manager. This language facility includes the sequence structures needed to handle batch or hybrid applications, as well as the computational capability needed for continuous control tasks. Key to the power of this control capability is the sharing of data within the HPM, and the sharing of data from other devices on the Universal Control Network.

All I/O values are converted to engineering units by the I/O Processors and are made available for both communications and further control processing by the High Performance Process Manager Module (see Figure 4).

The HPMM can be thought of as being partitioned into “slots” of various types. These slots provide allocated processing resource that can be user-configured, including assignment of a tag name. The mix of slots can be changed at any time without disrupting previously built tags.

A tagged slot is referred to as a data point in a TDC 3000^X system.

Table 1 — Regulatory PV Points

Available Algorithms	Supported Functions
Data Acquisition	PV Source (Auto, Manual, Substituted)
Flow Compensation	PV Clamping
Middle-of-3 Selector	EU Conversion & Extended PV Range
High/Low/Average Selector	PV Value Status and Propagation
Summer	PV Filter (Single Lag)
Totalizer	PV Alarming
Variable Dead Time with Lead/Lag	Bad PV
General Linearization	PV High/Low
Calculator	PV HiHi/LoLo
	PV Significant Change
	PV Rate-of-Change +/-
	Contact Cutout

Table 2 — Regulatory Control Data Points

Available Algorithms	Supported Functions
PID	Modes (Manual, Auto, Cascade, Backup Cascade)
PID with Feedforward	Mode Attribute (Operator, Program)
PID with External Reset Feedback	Normal Mode
PID with Position Proportional	Remote Cascade, Remote Request, and Remote Configurable Per Slot
Position Proportional	Initialization
Ratio Control w/Ramping Bias	Windup Protection
Ramp Soak	Output Fanning
Auto/Manual Station	Fixed or Auto Ratio and Bias
Incremental Summer	Override Propagation
Switch	External Mode Switching
Override Selector	Safety Shutdown
Multiply / Divide	Target Value Processing (Setpoint Ramping)
Summer	Alarms
	Limits (Output, Setpoint, Ratio, Bias)
	PV Source, PV Alarming
	Mode Shed on Bad PV

filtering, and algorithm equation options are provided. Available algorithms and other supported functions are listed in Table 1.

Regulatory Control Point

Configurable regulatory (or analog) control functions are performed using Regulatory Control points. Regulatory Control points are configured to execute one of the control algorithms listed in Table 2. Each algorithm includes a wide range of configurable options to allow implementation of complex control strategies by a simple menu-selection process. In addition, some functions, such as initialization and windup protection, are inherently provided. Also, the capability to ramp setpoint (by operator entry of a target value and ramp time) is configurable. Standard and custom graphic displays are available to support these control strategies.

This data point structure is supported by predefined group and detail displays, as well as by flexible custom graphics.

The following types of data points can be configured into HPMM slots:

- Regulatory PV
- Regulatory Control
- Digital Composite
- Logic
- Device Control
- Process Module
- Array
- Flag
- Numeric
- Timer
- String
- Time

and alarming, are handled directly by the I/O Processors, Regulatory PV points provide an easy-to-use configurable approach for implementing Process Variable (PV) calculation and compensation functions. PV processing provides a menu of selectable algorithms such as mass flow, totalization, and variable dead-time compensation. In addition, a full array of selectable functions, including extensive alarm checking and alarm suppression options, signal

These built-in support functions (see Table 2) significantly simplify the implementation and use of sophisticated multiloop control strategies. This ease of HPM configuration and operation allows implementation of advanced control strategies at the process-connected level.

Each of these data point types is discussed in the text that follows.

Regulatory PV Point

While standard I/O functions, such as engineering unit conversion

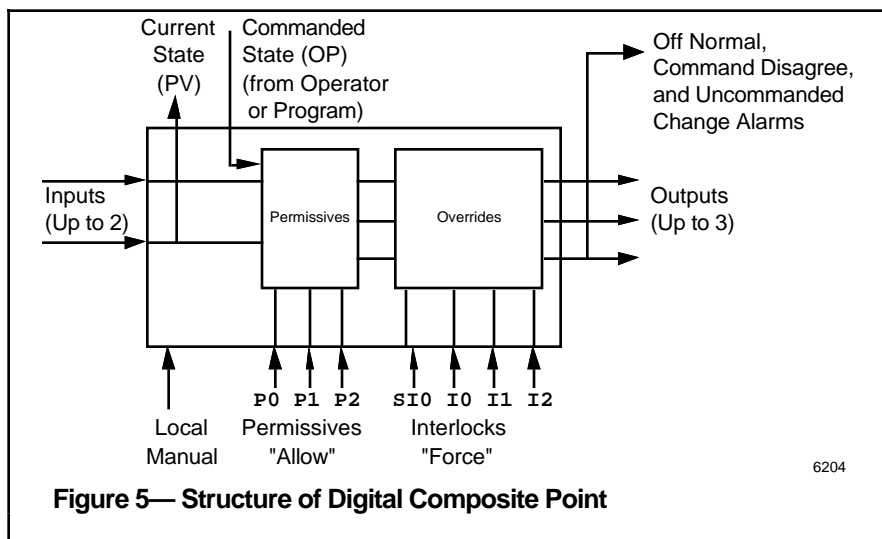

Figure 5— Structure of Digital Composite Point

Table 3 — Maximum Number of Entries for a Logic Point

	Inputs	Logic Blocks	Outputs
Option1	12	24	4
Option 2	12	16	8
Option 3	12	8	12
NOTE: Each logic point also provides six status flags and six user flags, plus eight numerics.			

Table 4 — Logic Block Algorithms

LOGIC (AND, OR, NOT, NAME, NOR, XOR, QUALIFIED- OR2, QUALIFIED-OR3, DISCREP3)
COMPARE REAL (EQ, NE, GT, GE, LT, LE)
DELAY (ON DELAY, OFF DELAY, DELAY)
PULSE (FIXPULSE, MAXPULSE, MINPULSE)
WATCHDOG TIMER
FLIP-FLOP
CHECK for BAD
SWITCH
CHANGE DETECT
NOTE: AND, OR, NAME, and NOR Gates accept up to three inputs per block, where each input can be optionally inverted.

Table 5 — Device Control Point Algorithms

Gate	Algorithms	Function
Primary Input	Null	Pass Logic Input without change
	Invert	Invert Logic Input
	Arithmetic	Greater than, Greater than or equal Less than, Less than or equal, Equal to, Not Equal to
Secondary Input	In-Set	Compare a numeric with an array of 10 numerics
	Null	Pass Logic Input without change
	Delay Pulse	Delay, On delay, Off delay Pulse, maximum pulse, minimum pulse (Time for delay and pulse < 8000 secs.)
Primary Gate	Logic Pulse	AND, OR, NAND, NOR, XOR PAND, POR, PNAND, PNOR, PXOR ("P..." outputs are pulsed)
Secondary Gate	Logic Pulse	AND, OR, NAND, NOR, XOR PAND, POR, PNAND, PNOR, PXOR ("P..." outputs are pulsed)

At the same time, the slot structure for processing and memory resources is designed to ensure that proper control security is built into advanced control strategies. This means that high reliability and integrity are maintained over the entire range of control.

Digital Composite Point

Digital Composite points are multi-input/multi-output points that provide an interface to discrete devices, such as motors, pumps, and solenoid valves. (see Figure 5)

This point provides built-in structures for handling interlocks. It supports operator displays of interlock conditions in group, detail, and graphic displays.

Displays also contain information needed to trace interlock cause. In addition, provision is made for operation of hand/off/auto switches commonly used for local operation of motorized devices.

The major parameters associated with the Digital Composite point are represented pictorially in Figure 5. Runtime maintenance statistics for the Digital Composite point device are also supported.

Logic Point

A Logic point provides a configurable mix of logic capability. Together with a digital composite point, it provides the basis for integrated interlock functions. Conceptually, a Logic point can be thought of as the logic processing equivalent to one to two pages of relay ladder logic. A Logic point consists of logic blocks, flags, numerics, input connections, and output connections. Different mixes of inputs, outputs, and logic blocks can be selected. Maximums for each type are shown in Table 3.

In addition to the logic block functions listed in Table 4, the Logic point provides a general-

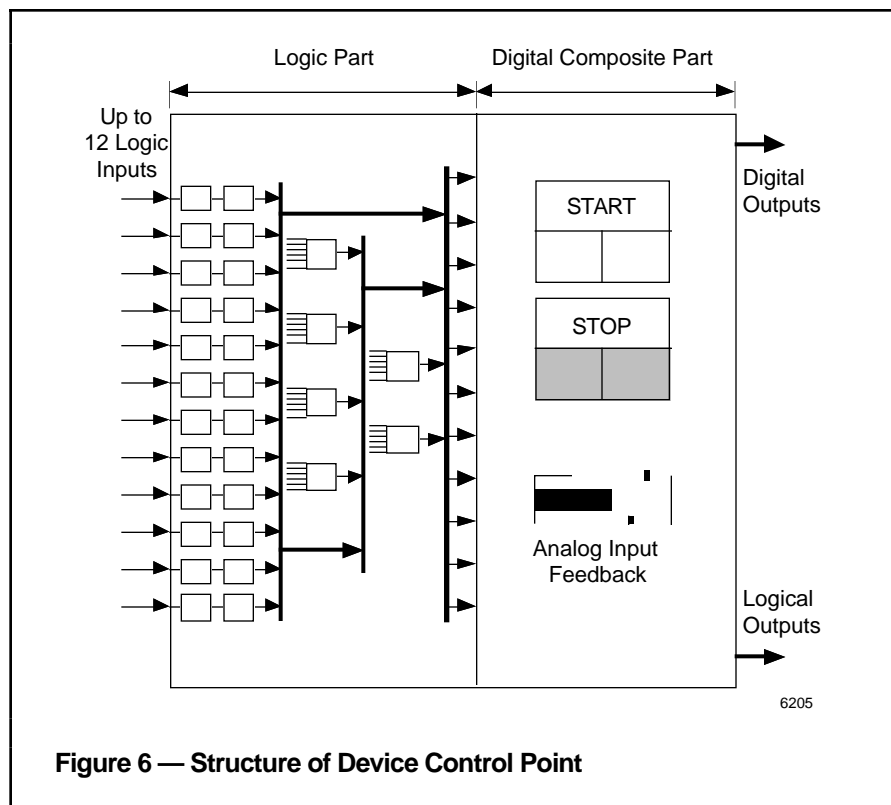

Figure 6 — Structure of Device Control Point

purpose data transfer capability that can be used to read data from input connections and store this data to other database parameters defined by the output connections.

Device Control Point

The Device Control point provides maximum flexibility for controlling discrete devices. It combines the digital composite display and logic control function under a single tag name (see Table 5 and Figure 6). This provides an enhanced interface for pumps, motors, and motor-operated valves.

The Device Control point's single tag name enhances the operator interface for motor control points.

Operations are improved because the operator can see the cause of the interlock. Also, an analog feedback signal, such as motor control current, is displayed.

Implementation effort is also reduced through the use of a simple configuration and standard graphics for troubleshooting.

User Programs— Process Module Point

Today's control strategies frequently need the flexibility of user programs that can be utilized for continuous, batch, or hybrid applications. A Process Module point is a resource for the execution of user-created programs written in Honeywell's Control Language (CL/HPM).

The CL language provides an outstanding sequential control and computational tool. CL programs are self-documenting—an important feature when future modification of control strategies is anticipated. The total statement capacity depends on configuration. Typically, 15,000 to 25,000 CL statements can be handled by a single HPM.

Using the Universal Station or Universal Work Station, individual programs can be easily modified and reloaded without affecting execution of regulatory control, logic blocks, and other user programs.

All process module programs can access the High Performance Process Manager database, thereby accessing analog inputs and outputs, digital inputs and outputs, array points, logic block states, alarm states, failure states, numeric variables, and flags.

CL/HPM programs can also manipulate ASCII values as well as time data. In addition, each process module program supports communication with the operator and can send or receive data from other controllers on the UCN.

Process module points provide a Phase/Step/Statement structure that is well suited for implementing batch process control functions.

In addition, a multilevel abnormal handling capability allows user-specified conditions to automatically trigger pre-defined Hold, Shutdown, or Emergency Shutdown sequences.

Array Point

The Array point provides a more flexible, easy-to-access point structure for user-defined data. It is especially useful for advanced control or batch sequence programs. For example, an Array point can be used to store calculation variables or batch recipe data. This Array point data is available to the system for local data acquisition and control strategies as well as historization.

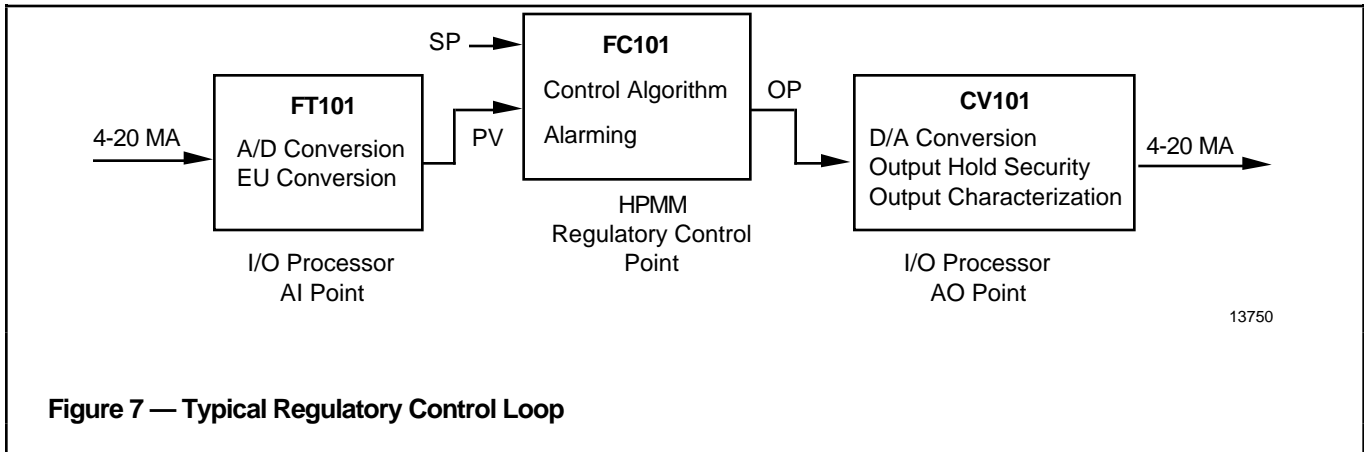

Figure 7 — Typical Regulatory Control Loop

Up to 500 Array points can be configured per HPM. Each array point is a logical grouping of internal HPM box global variables up to:

- 1023 Flags (boolean)
- 240 Numeric
- 240 Strings
- 240 Times

A subset of Array points can be used for Serial Interface (SI) communications. Up to 80 Serial Interface Array points can be accessed at a 1 second rate per HPM, 40 at a 1/2 second rate, or 20 at a 1/4 second rate.

A single Serial Interface Array point can handle:

- 512 Flags (Boolean) or
- 16 Numerics (Reals) or
- 32 Numerics (Integers) or
- 64 Characters of String Data.

Communication to any Serial Interface Array point is fully bidirectional (read and write). Data from any Serial Interface Array point can be accessed by other HPM control and CL functions such as Device Control points. This allows subsystem data to be used for HPM data acquisition and control strategies, as well as displayed at

the Universal Station, U^XS and UWS.

Flag Point

A Flag point is a two-state (On/Off) point that is used for storing a Boolean value. Flag points are not scheduled and are not processed. Their state is changed from another function, such as by operator input or a user-written program.

Provision is made for up to 16,384 Box Flag points, the first 128 of which can be configured for off-normal alarming.

Numeric Point

Numeric points are used for storage of real numbers. They are used for batch/recipe operations, or as a scratch pad to store the intermediate results of calculations. Like Flag points, they are not scheduled or processed, but are changed as the result of other system activity. There can be up to 16,384 Numeric points.

Timer Point

The Timer point allows for timing of process events by the operator or sequence program. After being started, it provides an indication when the elapsed time has reached a predefined limit.

There are 64 timer slots—each is processed once per second.

String

The String variable adds increased flexibility to both continuous and batch oriented CL control programs. String variables of 8, 16, 32, or 64 characters can be compared and modified by the HPM Control Language (CL). Using CL, you can manipulate and store unique messages that pertain to your process.

Also, with this Serial Interface, ASCII data from a subsystem can be imported and used as String variables, as well as written back to the subsystem. Up to 16,384 eight character strings are supported.

Time

The Time variables allow CL programs access to both time and date information. CL programs can use elapsed or actual wall-clock time. Time-dates can be added or subtracted as needed.

Time allows you to schedule CL programs by time of day. You can also construct control schemes by allowing a logic slot access to time of day information. Up to 4,096 times are supported.

Table 6 — Control Configuration Examples

Point Type ¹	Example 1				Example 2			
	Frequency (Seconds)	Pt.Qty.	PU/Pt.	Total PUs	Frequency (Seconds)	Pt.Qty.	PU/Pt.	Total PUs
Regulatory Control	1	150	1	150	0.5	80	2	160
Regulatory PV	1	100	1	100	0.5	40	2	80
Logic ²	1	100	1	100	0.25	25	4	100
Digital Composite ²	1	300	0.1	30	0.25	150	0.4	60
Device Control ²	1	150	1	150	0.25	50	4	200
Process Module	1	200	1 ³	200	1	100	2 ³	200
HPM Total	–	1000	–	730	–	445	–	800

¹ Array, Flag, Numeric, and Timer points are not listed since they have a PU weight of 0.
² Logic, Digital Composite and Device Control points must run at execution frequencies equal to, or faster than, the normal scan rate for regulatory points.
³ 1 PU for small or infrequently run programs; 2 PU for larger programs.

Control Implementation

A simple control loop can be implemented in a High Performance Process Manager, using an analog input point, a regulatory control point, and an analog output point as illustrated in Figure 7.

Although three data points are used, the primary operator interface is a single tag (FC101) for viewing, alarming, and manipulation in the customary manner through a Group, Detail, or Custom Graphic display.

Control Performance

The High Performance Process Manager is capable of processing an assured combination of regulatory and discrete control loops per second. Users can customize their control configuration to meet the application requirements. In addition, this control configuration can be changed at any time without affecting points already built.

The parallel processing architecture of the High Performance Process Manager allows the control processing of the HPM to be totally independent of other HPM functions, such as

the number of I/O points built, data requests for HPM data from the Network Interface Module and other UCN devices, and alarming functions. Only two factors must be considered when configuring the control processing—the type of control points (slots) desired, and their frequency of execution. The processing power of the High Performance Control Processor is measured in terms of “Processing Units (PUs).” Each High Performance Control Processor has an assured rate of 800 PUs per second. Regulatory, logic, digital composite, and device control points can be configured at different execution frequencies (1/4, 1/2, or 1 second).

A subset of these points can be configured for a 1/4-second rate, with the remainder at a slower rate. Since points use more processing power at faster frequencies, this feature allows the user to implement the greatest possible number of control loops while still assuring high-speed processing where required.

Still another option available for optimizing HPM configuration is the selection between two program sizes for Process Module points. Users with sequence programs that process

approximately 10 statements per second (or fewer) can implement twice as many such programs (250 instead of 125) as compared to sequence programs with more statements per step. This is possible because the smaller programs require less time to run and, therefore, are assigned only half as many Processing Units.

Typically, small programs are used for modular batch applications and large programs are used for continuous applications. Any mixture of point types can be used, subject to the following individual maximums:

- 250 Regulatory Control
- 125 Regulatory PV
- 400 Logic
- 999 Digital Composite
- 400 Device Control
- 250 Process Module at 1 PU per HPM program, or
- 125 Process Module at 2 PUs per HPM program

Table 6 shows two sample HPM configurations.

Write Lockout

To provide for applications requiring database protection, an added feature of the High Performance Process Manager is the capability for Write Lockout. When enabled, this feature blocks any HPM database changes via:

- the operator
- configuration
- peer-to-peer writes
- LCN writes

The feature is engineer key-lock enabled for maximum protection.

Alarm System Functions

HPM supports the extensive and flexible alarming capabilities of TDC 3000^X. As process alarms occur, they are visually announced at the Universal Station through keyboard LEDs and numerous types of displays, such as custom graphic displays, group displays, alarm annunciator displays, and alarm summaries. They can also be externally announced through customer-supplied devices activated by contact closures at the Universal Station. Because alarms can be reported on an area or unit basis, operators receive alarm indications that relate to only their specific assignments.

For HPM process variables, the following alarms can be configured:

- | | |
|----------------------------------|----------------------|
| • Hi | • Rate of Change Hi |
| • HiHi | • Rate of Change Lo |
| • Lo | • Significant Change |
| • LoLo | • Deviation Hi/Lo |
| • Bad PV | • Advisory Deviation |
| • Bad Output (RegCtl Point only) | |

All PV alarms can have a selectable deadband. Alarms can be assigned to both I/O Processors and HPMM slots. In general, to provide a single tag for operator

interface, when an I/O point is used by an HPMM slot, the alarms are configured in the HPMM slot.

The following digital alarm types are available:

- Uncommanded Change-of-State
- Off-normal alarms
- Command disagree alarms
- Logic input, flag, or gate output alarms
- Alarms forced by CL program
- Command Fail alarms
- User-defined alarms

Off-normal alarms feature a configurable time deadband. Command disagree, command fail, and uncommanded change-of-state are types of alarms that apply to digital composite points.

Alarm priority is individually configured for each alarm type used on a High Performance Process Manager point. There are seven selectable alarm priorities:

- Emergency
- High
- Low
- Journal
- Journal and Printer
- Printer Only
- No Action

Contact cutout is another configurable feature provided by the High Performance Process Manager. Contact cutout is used to automatically suppress alarm reporting on a point if certain external conditions occur.

Security

The High Performance Process Manager has a number of security features to provide maximum process availability. Throughout the HPM's design, a high-reliability

fault-tolerant approach to both circuitry and overall system architecture has been used. For example, by using an Application Specific Integrated Circuit (ASIC), an overall reduction in the number of components increases overall reliability and availability. CMOS technology, including highly heat-tolerant components, provides a high-density design with high reliability. Individual circuitry is used for critical functions, such as D/A converters on the output circuitry. Parallel power paths are employed so that control outputs can be maintained, even in the case of power regulator failure.

Redundancy for communications media, such as the I/O link and the UCN, is provided as a standard feature. Optional HPMM redundancy is offered to provide one-on-one backup and auto-switchover for the common electronics. Optional I/O redundancy for HLAI, STI, AO, DI and DO points can provide added security for critical control loops. Since redundancy options are designed into the product, automatic switchover from primary to redundant electronics is fully supported. No special user programming is required. Ongoing diagnostics are provided to assure both primary and redundant electronics are functional. This one-on-one redundancy approach enhances coverage to maximize availability. It also simplifies system cabling and configuration.

Optional power redundancy and battery backup can be provided for assured power availability.

Extensive self-diagnostics are employed to diagnose HPM operation and identify any failure. Failures are characterized as hard failure (HF) or soft failure (SF). HPM status is indicated locally through LEDs and a 4-character alphanumeric display, as well as at the standard status displays at the Universal Station.

Repairs to the HPM can be made easily by replacing boards while power is on. Analog and Digital Standby Manual Units are available to maintain process outputs during board replacement of non-redundant boards. Overall, the HPM provides superb control capabilities with excellent process control availability and security.

Physical Characteristics

The High Performance Process Manager consists of single or redundant High Performance Process Manager Modules, I/O Processors, associated card files, Field Termination Assemblies, and a single or redundant power assembly mounted in a cabinet. Either top or bottom field wire entry is available.

The use of advanced CMOS technology results in low power requirements and low heat dissipation. The High Performance Process Manager is also highly space-efficient because of flexible I/O architecture, low power use, and high-density terminations.

The HPM has been approved by Factory Mutual for mounting in, or interfacing to, devices in a Class 1, Division 2 area for the following signal types:

- Low Level Analog Input
- High Level Analog Input
- STI
- Analog Output
- Pulse Input
- 24 Vdc Digital Input

Power Systems

The High Performance Process Manager has significantly lower power requirements than traditional designs because it uses low-power CMOS technology. Two power systems are available to meet different system requirements.

The **standard HPM power system** provides an integrated system battery backup option. The power system can also be easily upgraded to redundancy in the field.

The **AC-Only power system** is intended for use with UPS systems and does not have provision for system battery backup. It can provide more cost effective power for a small, remote I/O installation where a UPS is available.

Both power systems provide 24 Vdc power to the High Performance Process Manager Module and I/O Subsystem. 24 Vdc transmitter power is provided through standard FTA connections. Both systems support single or redundant power supplies in a highly compact space. The standard system provides 50-hour memory backup and includes rechargeable batteries with a charger. The AC-Only power system uses alkaline batteries and provides somewhat lower memory backup time.

Each power supply on both systems provide a relay with a Form-A contact output that de-energizes (contact opens) in the event of power loss.

A single LED on each power module of the AC-Only system annunciates power loss, while the standard system has separate LED indicators for:

- Loss of ac power
- Loss of dc power
- Improper charging of backup battery
- Failure or disconnection of battery
- High temperature or cooling-fan failure

The standard HPM power system delivers 20 amps. Two power supply sizes are available for the AC-Only power system — 8 amp and 16 amp.

Card File Assemblies

A typical base HPM configuration consists of up to either 3 or 4 card files, depending on whether 15-slot or 7-slot files are used, as illustrated in Figure 9. When options such as I/O redundancy and/or remote I/O are used, configurations with up to 8 "logical" card files can be provided.

Figure 8 shows typical cabinet layouts with redundant HPMMs. Either one (non-redundant) or two (redundant) card files can contain the HPM Module(s). All remaining card file slots can be filled with any combination of I/O Processors.

Note: All card file types can be *completely* filled with IOPs. As shown in Figure 8, one side of a typical cabinet can hold up to 40 I/O Processors along with redundant High Performance Process Manager Modules.

Input/Output Functions

Please refer to IO03-500, *Process Manager I/O Specification and Technical Data* for more details, model numbers, and specifications.

The following is an overview of HPM I/O functions and capabilities.

Input/Output Processors

Input/Output Processors (IOPs), along with Field Termination Assemblies (FTAs), perform input and output scanning and processing on all field I/O. A redundant I/O Link is standard for added security. Most IOPs are available in a redundant configuration. I/O processing is performed separately from control processing functions, so that I/O scan rates are completely independent of I/O quantity, controller loading, processing, and alarming.

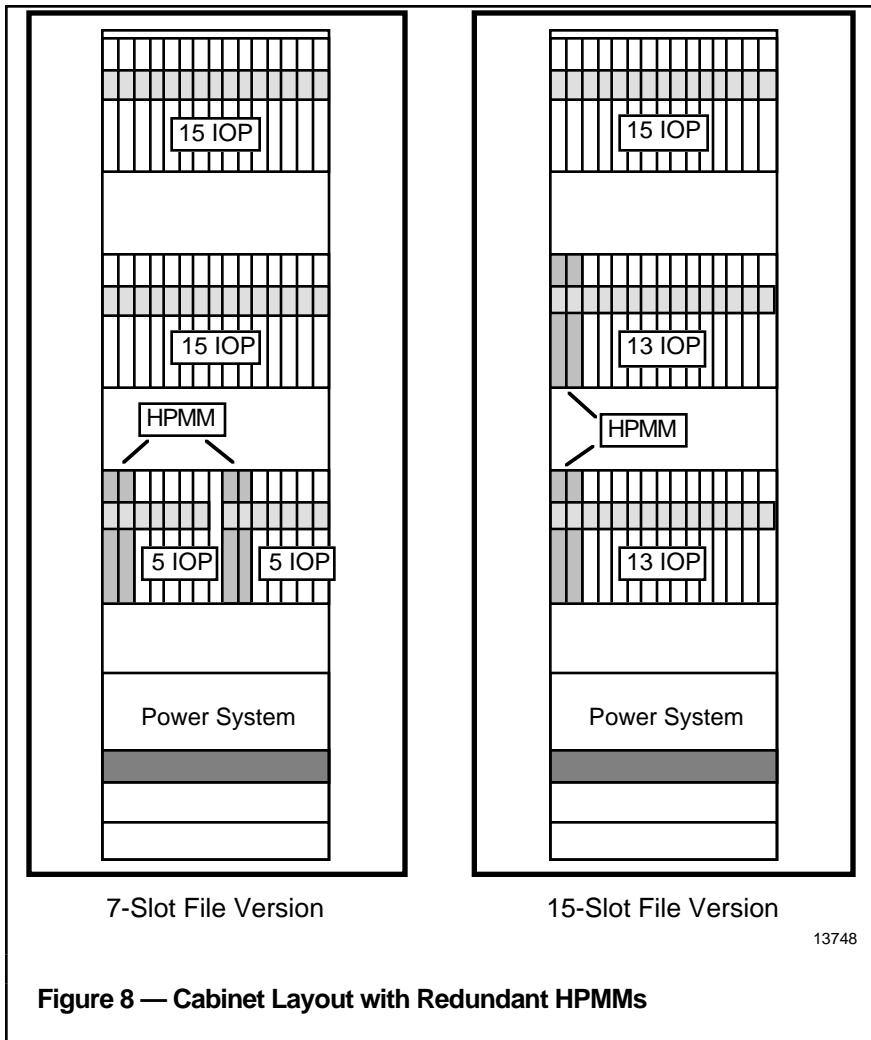

This partitioning of functions allows more efficient use of advanced control processor capabilities and provides for future I/O expansion.

A variety of I/O processors are available for the HPM:

- Analog Input—High Level (16 points)
- Analog Input—Low Level (8 points)
- Analog Input—Low Level Multiplexer (32 points)
- Smart Transmitter Multivariable Interface (16 points total)
- Analog Output (8 points)
- Analog Output (16 points)
- Serial Device Interface (16 points—2 ports)
- Serial Interface (32 arrays, 2 ports)
- Pulse Input (log ints)
 - 32 points)
 - 32 points)
- Analog Input SOE (32 points)
 - 16 points)
 - 32 points)

Any mix of the above I/O processors can be selected for an HPM. This can be any combination

Options

High Performance Process Manager Module Redundancy

In addition to the Universal Control Network, the I/O Link, and dc power cabling, which are always redundant, the High Performance Process Manager Module has a one-on-one redundancy option. In order to minimize the impact of a single failure, the database and functions within the backup HPMM are kept up-to-date with the primary. If failure of the primary is detected by diagnostics that are continually being executed, the backup HPMM automatically takes over from the primary and the operator is notified by a system alarm. The primary and secondary HPMM are located in separate card files to maximize control function availability.

Power System Redundancy

Both standard and AC-only power systems include the option for a redundant 24 Vdc power supply. In both cases, two different ac feeds can be used for the power system. No rearrangement of devices within a cabinet is necessary and, with the standard power system, the second power supply may be added at a future date.

I/O Redundancy

A one-on-one I/O redundancy option is also available for critical high level analog inputs, smart transmitter interface connections, analog outputs, digital inputs, and digital outputs. This option offers significantly increased availability of automatic control by providing continuous operation through failure and replacement of I/O Processors, FTA cables, and backplanes. Up to 40 I/O Processors can be supported in a redundant or non-redundant High Performance Process Manager, and the user can selectively apply

redundancy to some or all IOPs, for a maximum of 40 IOP pairs. The one-on-one design approach offers maximum coverage and fast switchover times. Integrity of the backup database and of the switching functions is provided through the extensive diagnostic coverage made possible by the processing capability of the smart I/O Processors.

Standby Manual

The 16-point digital output FTA and both analog output FTAs (8-point and 16-point) support connection to a standby manual unit. This option allows outputs to be maintained during I/O Processor replacement.

Battery Backup

An option to the standard HPM power system is a backup battery capable of providing regulated 24 Vdc power in the event of the loss of ac input power. The battery is a compact set of gel cells that is mounted within the cabinet's power system enclosure. A fully charged battery provides a minimum of 20 minutes of backup for a fully loaded High Performance Process Manager.

Diagnostic and alarm capabilities inform the operator of the existing state of readiness of the battery and charger.

Because the backup batteries provide input to the power supplies rather than powering the load directly, voltage regulation is equally as good when operating from either batteries or line power. If line power fails, load power is not interrupted during switchover.

For the AC-only power system, line power backup is typically achieved by connecting a UPS to one of the two ac feeds.

I/O Simulation Option

The optional HPM I/O Simulator package simulates the functions of the HPM's Input/Output Processors (IOPs). It is a low cost, high fidelity tool for database building, control strategy checkout, and operator training support without the need for IOPs to be present. A unique feature of this optional package is complete database transportability between the Simulation personality and the HPM On-Process (normal operating) personality. This is especially useful for configuring the system before the physical I/O is available or connected. Features of the package include:

- 'Bumpless' pause/resume interruption/restart
- Physical IOPs, FTAs and field wiring not required
- Simulation status indicated and journaled
- Data base (checkpoint) transportable to target system
- Simulation rerun from saved data base using PV data
- Full peer-to-peer capability
- I/O functions simulated by Communications processor
- Any I/O configuration can be simulated
- Simulation load and status supported on system network
- Fault response testing & I/O redundancy simulation

The benefits of this package include:

- The ability to perform high fidelity simulation
- Control strategy checkout
- Operator training
- Project cost savings

Remote I/O

Two Remote I/O options are available. Both enable distribution of I/O Processors and FTAs at up to six remote sites. One option supports remote sites up to 1 kilometer from the main HPM electronics, while the second option provides for separation of up to 8 kilometers. FTAs at the remote locations can be located an additional 50 meters from the I/O processors, and LLAI Mux, Serial Device or Serial Interface FTAs can be placed an additional 300 meters away.

The result can be a significant reduction of signal wire runs. Since redundant fiber optic cables are used, remote I/O installation benefits from inherent immunity to ground potential differences, and EMI/RFI interference. The redundant links each require an I/O Link Extender Pair (IOLE) at both ends. The Remote I/O (1 km) option supports up to three remote sites for each IOLE at the HPM end, while the Long Distance I/O (8 km) option requires one HPM IOLE per site.

Corrosion Protection Option

As electronic board layouts have become more compact, sensitivity to corrosion has increased. In addition, a trend toward locating I/Os closer to the process to save installation costs has generated a requirement for environmentally hardened products. To provide extra corrosion protection when HPM equipment cannot be located in a mild (G1) environment, HPMM boardsets are conformally coated as a standard feature. These boards are completely covered with a thin plastic film resistant to the corrosive effects of humidity and certain gases, and are thus suitable for placement in a harsh (G3) atmosphere. Coating is optional for most HPM system components, such as IOPs, FTAs, power supplies, backplanes and

processor boards. Many components are coated as a standard, such as the HLAI IOP, AO IOP, 20 amp HPM power supply and HPM controller board set.

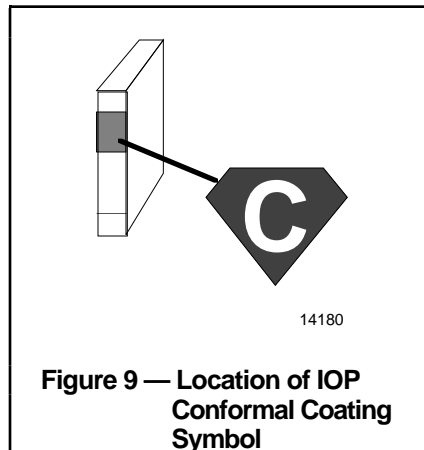

All coated products are denoted by a “C” in the second character of their model number. Uncoated boards maintain the standard MU-xxxxxx style numbers; therefore, all products for which conformal coating is available have two model numbers. For example, the uncoated DI IOP model number is MU-PDIX02, and the coated version is MC-PDIX02. In order to easily identify coated IOPs in the field, they are labeled with a distinctive symbol located on their faceplate (see Figure 9). The “C” surrounded by a solid diamond (the universal symbol of hardness) represents the protection this conformal coating process provides.

Note: Boards installed and maintained in a G1 (mild) control room environment (defined by the ISA Environmental Severity Classification) do not need this added protection.

Harsh Environment Option

To help reduce wiring and installation costs, as well as free up valuable control room space, a **Remote Hardened I/O (RHIO)** NEMA4X sealed cabinet option is

available for remotely mounting HPM I/O. Backplanes and power supplies included with RHIO are conformally coated. When populated with conformally coated IOPs, FTAs, and Fiber Optic Extenders, the RHIO option provides a GX 'Severe' environment product rating against corrosion due to humidity and corrosive gases in remote locations.

The IOP cabinet accommodates a 7-slot file and a redundant 8-amp power supply and is available as a standard product; the FTA cabinet must be custom ordered due to the many variations of FTA sizes and layouts.

European Community (EC) Compliance

The HPM is available in compliance with European Community (EC) directive requirements, denoted by the “CE mark” (Communauté Europeene). This compliance extends to the HPMM, cardfiles, power supplies, IOPs and FTAs, as well as to Rittal cabinets. As of January 1, 1996, all goods imported into the European community or moving between member countries must be compliant with the new EC directives.

For HPM, customers must choose whether or not CE compliance is needed. HPMMs, IOPs, and power supplies are only available CE-compliant. For cardfiles and *some* FTAs, both compliant and non-compliant versions are available. Only Rittal cabinets are CE-compliant. Please refer to **IO03-500, Process Manager I/O Specification and Technical Data**, for IOP/FTA details.

Note that the following are some of the conditions required in order for CE compliance to be met:

- All FTAs must be connected to IOPs (no unconnected parts).
- Shielded FTA cables must be used if outside a cabinet.
- The system must be mounted into a Rittal cabinet per Honeywell specifications.
- All cabinet doors must be fully closed.
- Standard Honeywell/Rittal mounting plate and channels must be used.
- The system must be installed according to the Honeywell instructions.
- The system must be grounded per Honeywell instructions.

Specifications

Specifications apply to the HPM modules mounted in a standard HPM cabinet.

High Performance Process Manager Environmental Conditions

Parameter	Reference Band	Normal Limits	Operative and Storage Limits	Transportation Band
Ambient Temperature ^(1,2) Range Rate of Change	25 ± 1°C None	0-50°C ≤0.25°C/min.	0-50°C ⁽²⁾ ≤1°C/min.	-40 to 80°C ⁽³⁾ ≤5°C/min.
Relative Humidity ⁽⁴⁾	15-55%	15-70%	10-90% (No Condensation)	5-95%
Vibration (3 major axes) Frequency Acceleration Displacement	None	10-60 Hz 0.1 g maximum 0.03 inches	10-60 Hz 0.5 g maximum 0.1 inches	0-60 Hz 1 g maximum 0.1 inches
Mechanical Shock Acceleration Duration	None	1 g maximum 30 ms maximum	5 g maximum 30 ms maximum	20 g maximum 30 ms maximum
Barometric Pressure Altitude	Sea Level	+3000 m/-300 m	+3000 m/-300 m	any
Corrosives ⁽¹⁾ MC-	–	Class G3 (coated)	Class G3 (coated)	Class G3 (coated)
Electromagnetic Interference ⁽¹⁾	–	15 V/M	15 V/M	–
Electrostatic Discharge	–	IEC 801-2 15 kV 20x once/5 seconds	IEC 801-2 15 kV 20x once/5 seconds	–
Surge	–	IEEE/ANSI C37.90.1-1989		
<p>(1) External to standard HPM cabinet with doors closed. Class G3 (harsh) environmental rating applies to the system only if all system components are conformally coated (MC-xxxxxx models) where available (not applicable, for example, to cables and cabinets). Otherwise, a class G1 (mild) environmental rating applies to the system.</p> <p>(2) HPM boards are nominally rated for 0-70°C. This allows for a 15 °C temperature rise inside the cabinet when the external temperature is 0-50 °C, based on allowable hardware configurations inside a cabinet with the door(s) closed.</p> <p>(3) Battery backup option must be transported and stored at temperatures -40 to +85°C.</p> <p>(4) The maximum relative humidity specification applies up to 40°C. For 50°C, the RH specification is derated to 55% to maintain constant moisture content.</p>				

Specifications (continued)

HPM Certifications⁽¹⁾

For:	Certifying Agency
General Purpose Area	FM, CSA
Class 1, Division 2 Mounting ⁽¹⁾	FM
Class 1, Division 2 Interfacing, without barriers ⁽¹⁾	FM
⁽¹⁾ Received and Pending. Certification marking provided only if requested in sales order. For further details, see the HPM Site Planning Manual, Section 13.	

European Community Compliance (CE-Mark)

CE Conformity (Europe)	<p>This product is in conformity with the protection requirements of the following European Council Directives: 73/23/EEC, the Low Voltage Directive, and 89/336/EEC, the EMC Directive. Conformity of this product with any other “CE Mark” Directive(s) shall not be assumed.</p> <p><i>Deviation from the prescribed procedures and conditions specified in the installation manuals may invalidate this product’s conformity with the Low Voltage and EMC Directives.</i></p>
Product Classification	Class I: Permanently mounted, permanently connected Industrial Control Equipment with protective earthing (grounding). (EN 61010-1-1993)
Enclosure Rating	The HPM is sold to users in a lockable cabinet which prevents OPERATOR access to live parts, thereby providing protection against shock hazard. If a user installs parts of a Process Manager outside of the standard cabinet, they must be in an equivalent enclosure.
Installation Category	Category II: Energy-consuming equipment supplied from the fixed installation. Local Level Appliances and Industrial Control Equipment . (EN 61010-1-1993)
Pollution Degree	Pollution Degree 2: Normally non-conductive pollution with occasional conductivity caused by condensation. (IEC 664-1-1992)
EMC Classification	Group 1, Class A, Industrial, Scientific and Medical (ISM) Equipment. (EN55011-1991; Emissions)
Method of Assessment	EMC: Technical Construction File (TCF) LVD: Technical File (TF)

High Performance Process Manager Standard Power Systems⁽¹⁾

Electrical Specifications			
Parameter	Reference	Normal Band	Operating Limits
120/240 Vac Input⁽²⁾			
Voltage (Vac rms)	120 or 240 ± 1	100-264	100-264
Current (amps)			
- Maximum Inrush (Peak)	35	--	--
- Running (rms)	9 amps max.	--	--
- Crest Factor	1.1 max.	--	--
- Power Factor	0.95 min.	--	--
Frequency	50/60 ± 0.1	47-63	47-63
Total Harmonic Distortion	0	0-8%	0-8%
DC Output			
Voltage (Vdc) powered from ac	25.5	25-26	25-26
Current (amps)	20	0-20	0-20
Voltage (Vdc) powered from batteries	24.5	24-25	24-25
Hold-Up Time (any supply voltage)	25 ms (Nominal line and full load—without batteries)		
Efficiency (any supply)	65% minimum		
System Battery Backup Specifications			
Parameter	Specification		
Environment	See Environmental Conditions		
Battery Type	48 Vdc (bulk), 12 amp-hours (sealed gel-cell)		
Battery Life	5 years at 20°C ambient in an operating system		
Switchover, Switchback Time	Instantaneous—diode switching		
CMOS Memory Backup Specifications			
Parameter	Specification		
Environment	See Environmental Conditions		
Battery Type	Three 1.2 Vdc, size C nickel-cadmium cells		
Battery Life	5 years		
Switchover, Switchback Time	Instantaneous—diode switching		
Worst Case Minimum HPM Memory Backup Time	50 hours with size C nickel-cadmium cells 10 hours with size AA nickel-cadmium cells		
(1) A redundant HPM requires a redundant power supply.			
(2) The supply is intended to work on nominal voltages of 120V (100-132) or 240V (187-264). It is not necessary for the user to make any adjustments to do this.			
(3) The temperature range for full output is -20 to +55 degC. Between 55 and 65 degC, derate the output 1/2 amp per degC.			

High Performance Process Manager AC-Only Power Systems

Electrical Specifications			
Parameter	Reference	Normal Band	Operating Limits
120 Vac Input⁽¹⁾			
Voltage (Vac rms)	120	100-132	100-132
Current (amps)			
- Maximum Inrush (Peak)	30	--	--
- Running (rms) for 8 amp PS	3.5 max.	--	--
- Running (rms) for 16 amp PS	6.5 max.	--	--
- Crest Factor	2.8 max.	--	--
Frequency	50/60	47-63	47-63
Total Harmonic Distortion	0	0-8%	0-8%
240 Vac Input⁽¹⁾			
Voltage (Vac rms)	240	200-264	200-264
Current (amps)			
- Maximum Inrush (Peak)	30	--	--
- Running (rms) for 8 amp PS	2.0 max.	--	--
- Running (rms) for 16 amp PS	3.3 max.	--	--
- Crest Factor	2.8 max.	--	--
Frequency	50/60	47-63	47-63
Total Harmonic Distortion	0	0-8%	0-8%
DC Output			
Voltage (Vdc) powered from ac	25	24.5-25.5	24.5-25.5
Current (amps) for 8 amp PS (2, 5)	8	0-8	0-8
Current (amps) for 16 amp PS (2, 5)	16	0-16	0-16
Hold-Up Time (any supply voltage)	20 ms (Nominal line and full load)		
Efficiency (any supply)	75% minimum		
CMOS Memory Backup Specifications			
Parameter	Specification		
Environment ⁽⁵⁾	See Environmental Conditions		
Battery Type	Three size AA alkaline cells		
Battery Recharge	Not rechargeable; replace after any use		
Battery Life	One year if not used—10 hours minimum when used		
Switchover, Switchback Time	Instantaneous—diode switched		
<p>(1) Input voltage is factory set—cannot be changed in the field.</p> <p>(2) Output current and redundancy are factory configured. They cannot be changed in the field.</p> <p>(3) A redundant HPM requires a redundant power supply.</p> <p>(4) The ac-only power supply is not CE-compliant.</p> <p>(5) The temperature range for full output is 0 to +50 degC. Between 50 and 71 degC, derate the output linearly to 50% of rated load.</p>			

HPMM Redundancy Option*

Parameter	Specification
Control Hold Due to Swap or Failover Typical Maximum	2 seconds 5 seconds
*Note: A redundant HPM requires a redundant power supply.	

I/O Link Extender (Remote I/O)

Parameter	Specification	
	Remote I/O Link Extender	Long Distance I/O Link Extender
Fiber Link Length	1.2 km	8 km
Fiber Size	62.5/125 μm	62.5/125 μm
Wave Length	820 nanometers	1300 nanometers
Fiber Power Budget Over-Temperature Range	5.5 db	10.0 db
Note: Fiber optic cables are supplied by outside vendors in accordance with Honeywell specifications. For additional information, see the <i>High Performance Process Manager Site Planning Manual</i> , Section 17.		

Model Numbers – High Performance Process Manager

Description	Uncoated Model Number	Coated Model Number
High Performance Process Manager Module Board Sets		
High Performance Process Manager Module Board Set — Single	--	MC-HPMS01 ⁽³⁾
High Performance Process Manager Module Board Set — Redundant	--	MC-HPMR01 ⁽³⁾
Upgrade Kits		
HPM 15-Slot Non-Redundant to Redundant Upgrade Kit, Non-CE	--	MC-ZHMR01
HPM 7-Slot Non-Redundant to Redundant Upgrade Kit, Non-CE	--	MC-ZHMR02
APM/PM to HPM Upgrade Kit (Non-redundant) , Non-CE	--	MC-ZHPS01
APM/PM to HPM Upgrade Kit (File-to-File Redundant) , Non-CE	--	MC-ZHPR01
APM/PM to HPM Upgrade Kit (Side-by-Side Redundant) , Non-CE	--	MC-ZHPR02
APM/PM (Non- Redundant) to HPM (Redundant) Upgrade Kit, Non-CE	--	MC-ZHPR03
Card Files (Telephone Connector Version)		
HPM 7-Slot file, Slots 1-7, Empty, Non-CE	MU-HPFH01	MC-HPFH01
HPM 7-Slot file, Slots 9-15, Empty, Non-CE	MU-HPFH11	MC-HPFH11
HPM 15-Slot file, Empty, Non-CE	MU-HPFX02	MC-HPFX02
HPM+I/O 7-Slot file, Slots 1-7, Empty, CE ⁽¹⁾	MU-HPFH03	MC-HPFH03
HPM+I/O 7-Slot file, Slot 9-15, Empty, CE ⁽¹⁾	MU-HPFH13	MC-HPFH13
HPM+I/O 15-Slot file, Empty, CE ⁽¹⁾	MU-HPFX03	MC-HPFX03
I/O-Only 7-Slot file, Slots 1-7, Empty, CE ⁽¹⁾	MU-HPFI03	MC-HPFI03
I/O-Only 7-Slot file, Slot 9-15, Empty, CE ⁽¹⁾	MU-HPFI13	MC-HPFI13
I/O-Only 15-Slot file, Empty, CE ⁽¹⁾	MU-HPFI23	MC-HPFI23
HPM-to-I/O File Conversion Kit, CE ⁽¹⁾	MU-ZPFI03	--
HPM Center Filler Plate, Slot 8	MU-HPFP01	--
HPM 8-Slot Cover Plate	MU-HPCP01	--
HPM Redundancy Cable	51201667-100	--
HPM Fuse Puller	51309123-100	--
HPM Cardfile Mounting Bracket	51404256-100	--
HPM Software Option⁽²⁾		
HPM/APM I/O Simulator Software Option	MU-SWSM22	--
<p>(1) For CE-compliance, separate "I/O Only" and "HPM+I/O" cardfiles are required (available in coated and uncoated versions). A conversion kit, MU-ZPFI03, is available if necessary to convert an "HPM+I/O" cardfile to an "I/O Only" version.</p> <p>(2) Software package includes I/O simulation personalities for <i>both</i> APM and HPM.</p> <p>(3) HPMMs (as well as upgrade kits) are ONLY available conformally coated.</p>		

Model Numbers (continued)

Description	Model Number
Cabinets and Cabinet Components (Markhon Style)	
Cabinet — Dual Access (.8 W x .8 D x 2.1 H [meters])	MU-CBDM01
Cabinet — Single Access (.8 W x 5.5 D x 2.1 H [meters])	MU-CBSM01
Cabinet Lifting Eyebolts (4)	MU-CLBM01
Cabinet (Dual Access) Forklift Base	MU-CFDM01
Cabinet (Single Access) Forklift Base	MU-CFSM01
Cabinet Trim File Filler Panel	MU-CTFP11
Vertical Trim Panel Set — Full Height	MU-CTVF11
Vertical Trim Panel Set — Half Height	MU-CTVH11
FTA Mounting Channel — Narrow	MU-TMCN11
FTA Mounting Channel with Shield Ground Bar — Narrow	MU-TMCN12
FTA Mounting Channel — Wide	MU-TMCW11
FTA Mounting Channel with Shield Ground Bar — Wide	MU-TMCW12
Cabinets and Cabinet Components (Rittal Style)	
Cabinet — Dual Access (.8 W x .8 D x 2 H [meters])	MU-CBDX01
Cabinet — Single Access (.8 W x .5 D x 2 H [meters])	MU-CBSX01
Cabinet Trim File Filler Panel	MU-CTFP01
Vertical Trim Panel Set — Full Height	MU-CTVF01
Vertical Trim Panel Set — Half Height	MU-CTVH01
FTA Mounting Channel — Narrow	MU-TMCN01
FTA Mounting Channel with Shield Ground Bar — Narrow	MU-TMCN02
FTA Mounting Channel — Wide	MU-TMCW01
FTA Mounting Channel with Shield Ground Bar — Wide	MU-TMCW02

Description	Uncoated Model Number	Coated Model Number
Cabinet Fan Assemblies (All Styles)		
Cabinet Fan Assembly (240 Vac-50/60 Hz)	MU-FAN501	n/a
Cabinet Fan Assembly with Alarm (240 Vac-50/60 Hz)	MU-FAN511	MC-FAN511
Cabinet Fan Assembly (120 Vac-50/60 Hz)	MU-FAN601	n/a
Cabinet Fan Assembly with Alarm (120 Vac-50/60 Hz)	MU-FAN611	MC-FAN611

Model Numbers (continued)

Description	Uncoated Model Number	Coated Model Number
Power Systems Including, or Upgradable to, System Battery Backup PM/APM/HPM Redundant Power System with Mounting (20 A) PM/APM/HPM Single Power System with Mounting (20 A) PM/APM/HPM Redundant Power System w/ Sys. Battery Backup Mounting (20 A)	MU-PSRX04 MU-PSSX04 MU-PSRB04	MC-PSRX04 MC-PSSX04 MC-PSRB04
AC-Only Power Systems AC-Only Redundant Power Supply 120 Vac (8 A) AC-Only Redundant Power Supply 240 Vac (8 A) AC-Only Single Power Supply 120 Vac (8 A) AC-Only Single Power Supply 240 Vac (8 A) AC-Only Redundant Power Supply 120 Vac (16 A) AC-Only Redundant Power Supply 240 Vac (16 A) AC-Only Single Power Supply 120 Vac (16 A) AC-Only Single Power Supply 240 Vac (16 A)	MU-PAR111 MU-PAR211 MU-PAS111 MU-PAS211 MU-PAR121 MU-PAR221 MU-PAS121 MU-PAS221	MC-PAR111 MC-PAR211 MC-PAS111 MC-PAS211 MC-PAR121 MC-PAR221 MC-PAS121 MC-PAS221
AC-Only Power System Cover Plate	MU-PACP01	MC-PACP01
24 Vdc Power Distribution Power Distribution FTA (24 Vdc)	MU-TDPR02	MC-TDPR02

Model Numbers (continued)

Description	Model Number
UCN Cables (Indoor Use)	
UCN RG-6 Drop Cable Pair (In Cabinet)	MU-NKD000
UCN RG-6 Drop Cable Pair (2 m)	MU-NKD002
UCN RG-6 Drop Cable Pair (5 m)	MU-NKD005
UCN RG-6 Drop Cable Pair (10 m)	MU-NKD010
UCN RG-6 Drop Cable Pair (20 m)	MU-NKD020
UCN RG-6 Drop Cable Pair (30 m)	MU-NKD030
UCN RG-6 Drop Cable Pair (40 m)	MU-NKD040
UCN RG-6 Drop Cable Pair (50 m)	MU-NKD050
UCN RG-6 Drop Connectors Kit (24 Connectors)	MU-NKDK01
UCN RG-6 Trunk Cable Crimp Tool	MU-NKDT01
UCN RG-11 Trunk Cable Pair (2.5 m)	MU-NKT002
UCN RG-11 Trunk Cable Pair (5 m)	MU-NKT005
UCN RG-11 Trunk Cable Pair (10 m)	MU-NKT010
UCN RG-11 Trunk Cable Pair (20 m)	MU-NKT020
UCN RG-11 Trunk Cable Pair (30 m)	MU-NKT030
UCN RG-11 Trunk Cable Pair (50 m)	MU-NKT050
UCN RG-11 Trunk Cable Pair (100 m)	MU-NKT100
UCN RG-11 Trunk Cable Pair (200 m)	MU-NKT200
UCN RG-11 Trunk Cable Pair (400 m)	MU-NKT400
UCN RG-11 Trunk Cable Pair (600 m)	MU-NKT600
UCN RG-11 Trunk Connectors Kit (24 Connectors)	MU-NKTK01
UCN RG-11 Trunk Cable Crimp Tool	MU-NKTT01
UCN RG-11 Trunk Cable Splice Kit (10 in a Package)	MU-NCSK01
UCN RG-11 Raw Cable (152 m)	51190899-152
UCN RG-11 Raw Cable (305 m)	51190899-305
UCN RG-11 Raw Cable (762 m)	51190899-762
UCN Cables (Outdoor Use)	
UCN RG-11 Raw Cable (152 m)	51191607-152
UCN RG-11 Raw Cable (305 m)	51191607-305
UCN RG-11 Raw Cable (762 m)	51191607-762
UCN Taps	
UCN Tap Pair with 2 Drops per Tap (with Brackets)	MU-NTAP02
UCN Tap Pair with 4 Drops per Tap (with Brackets)	MU-NTAP04
UCN Tap Pair with 8 Drops per Tap (with Brackets)	MU-NTAP08
UCN Tap Torque Tool Kit	MU-NKTQ01

Copyright, Trademarks, and Notices

The following are trademarks of Honeywell Inc.:

TDC 3000 system

Process Manager

All other brand or product names appearing herein are trademarks of their respective companies or organizations.

While this information is presented in good faith and believed to be accurate, Honeywell disclaims the implied warranties of merchantability and fitness for a particular purpose and makes no express warranties except as may be stated in its written agreement with and for its customer.

In no event is Honeywell liable to anyone for any indirect, special or consequential damages. The information and specifications in this document are subject to change without notice.