

8-Node Enhanced Micro TDC 3000X Specification and Technical Data

MT03-520
R500
1/96

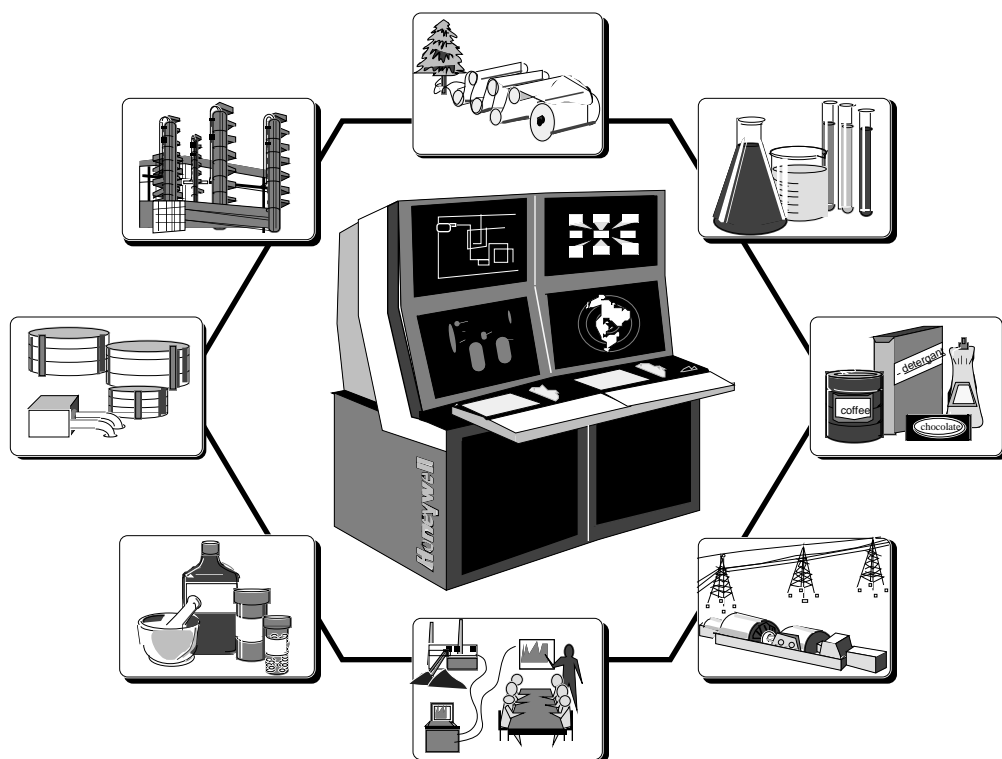

8-Node Enhanced Micro TDC 3000

Specification and Technical Data

Table of Contents	Page
Introduction	2
Architecture	2
Functional Overview	4
System Configuration	4
System Communication	4
Local Control Network	4
Universal Control Network	5
Network Interface Module	5
Process-Connected Data	
Acquisition and Control	5
Advanced Process Manager	5
Information Processing and	
Advanced Control	10
Universal Station	10
Application Module	11
History Module	13
System Peripherals	14
Optional TPLCN Nodes	14
References	15
Specifications	16

Introduction

The Enhanced Micro TDC 3000 is a very powerful, standalone small system, cost-optimized for continuous, batch and sequential logic applications. It is ideal for customers who need the functionality of Honeywell's TDC 3000^X system, but also require a smaller system size and footprint at a significantly lower cost.

The Enhanced Micro TDC 3000 system provides all of the power and capability of a standard Honeywell TDC 3000^X LCN/UCN-based system, in a smaller, more cost-efficient package having a prebuilt network, area and point database. Almost all the application solution packages that run on the standard TDC 3000^X system can be run on the Enhanced Micro TDC 3000 system.

While the Enhanced Micro TDC 3000 is an excellent small system, it should be noted that the standard TDC 3000^X system is the preferred choice for those critical process applications that require a very high degree of system reliability, robustness or redundancy. Enhanced Micro TDC 3000 is not intended for such applications, and should not be used in place of a standard TDC 3000^X system in such situations.

Architecture

Figure 1 is an illustration of a typical Enhanced Micro TDC 3000 system. It consists of an Advanced Process Manager (APM) cabinet plus two other cabinets (called "towers") that contain additional electronics, two Bernoulli (cartridge) drives, and a hard disk drive.

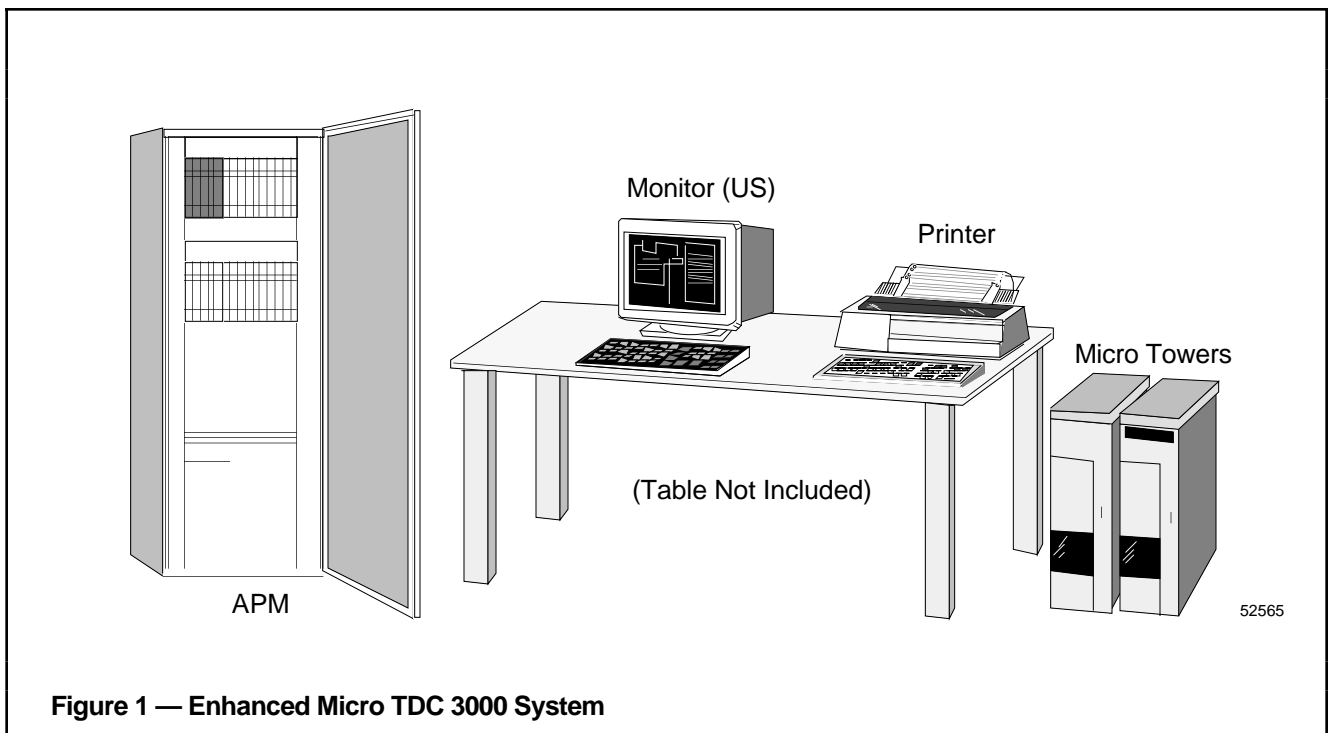

Figure 1 — Enhanced Micro TDC 3000 System

Other system components include color monitor(s), keyboard(s), an optional touchscreen or trackball, and a printer, all of which are supported by the electronics in the two towers.

The electronics in the towers are patterned after (but not identical to) the standard TDC 3000^X LCN nodes such as the Application Module (AM), History Module (HM), Network Interface Module (NIM), and the Universal Station (US).

Each tower has a multinode module (cardfile) capable of housing up to four nodes using K2LCN¹ processors, thus allowing a maximum of eight nodes per Enhanced Micro TDC 3000 system. Of these eight nodes, up to four may be Universal Station (US) nodes. The two towers are connected by a Twisted Pair Local Control Network (TPLCN) cable.

The Network Interface Module (NIM) allows the tower (LCN) nodes to communicate with the process over the Honeywell Universal Control Network (UCN). The process itself is monitored and controlled by the APM (Advanced Process Manager), which resides on the UCN, and is connected to the LCN nodes via the NIM. The APM is an integral part of the Enhanced Micro TDC 3000 system.

Figure 2 shows the architecture of a typical Enhanced Micro TDC 3000 system, depicting the nodes used to construct this sample system. As may be seen in Figure 2, a second (optional) NIM may be installed in Tower #2 to also connect to the APM and provide redundancy. (The standard NIM supplied with all Enhanced Micro TDC 3000 systems is in Tower #1.)

¹K2LCN is Honeywell's proprietary processor board that utilizes a Motorola 68020 microprocessor chip.

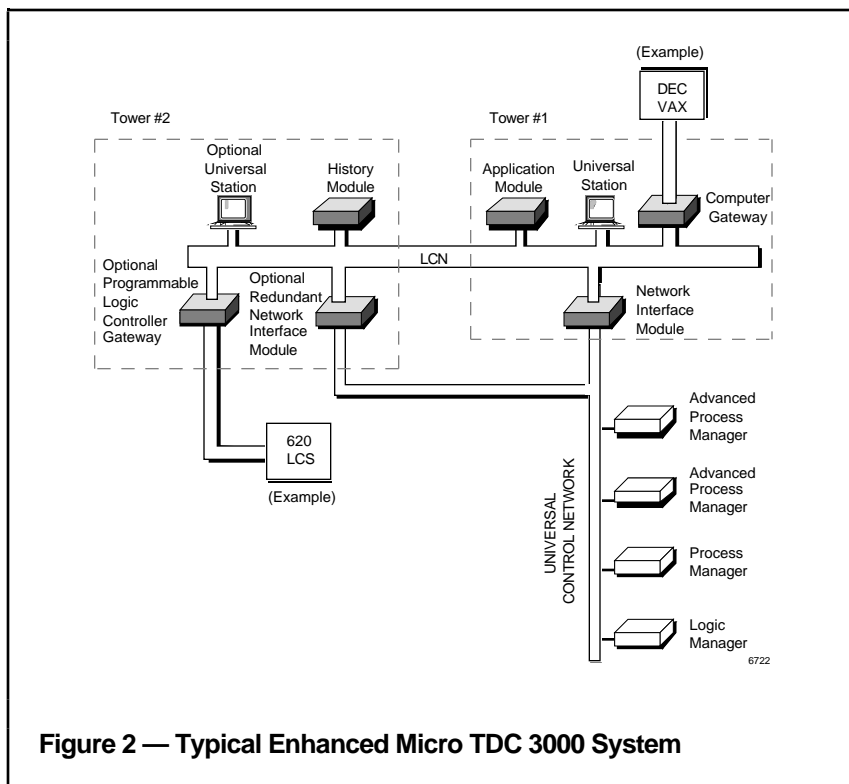

Figure 2 — Typical Enhanced Micro TDC 3000 System

Also supplied as standard nodes with all Enhanced Micro TDC 3000 systems are an AM (Application Module) and a US (Universal Station)², both of which are also housed in Tower #1, and an HM (History Module) which is installed in Tower #2.

Other optional nodes such as additional USs, Computer Gateway (CG), Network Gateway (NG), and PLC Gateway (PLCG) are also available and may be installed in the towers to expand the system (up to a maximum of eight nodes). A short functional description of each of these system expansion options is given on page 14 (see "Optional TPLCN Nodes").

Each tower (i.e., multinode cardfile) has an independent power supply, which is shared by all the nodes installed in that tower.

²Some ("Version B") Enhanced Micro TDC 3000 systems have a second US supplied as standard with the system, which is installed in Tower #2.

Thus, up to four nodes could share a single power supply (unlike the standard TDC 3000^X system, where each node has an independent power supply). Following is a brief description of the standard LCN/UCN nodes supplied with an Enhanced Micro TDC 3000 system (see "Specifications" for additional technical information):

- **Universal Station (US):** Provides a window to the process, and allows information from process-connected devices, instrumentation subsystems, and computers to be seen and used. The US(s) supplied as standard with all Enhanced Micro TDC 3000 systems support the "Universal" personality. Optional USs that support either "Universal" or "Operator" personalities are also available (see "Optional TPLCN Nodes").
- **Application Module (AM):** Performs calculations and advanced control strategies that are not possible or practical using only process-connected devices.

There is one AM per Enhanced Micro TDC 3000 system. The AM is offered in two standard memory sizes — 2 Mw or 8 Mw.

- **History Module (HM):** Provides mass storage of software, system data, and customer data on a hard disk drive. There is one HM per Enhanced Micro TDC 3000 system.
- **Network Interface Module (NIM):** Connects the Enhanced Micro TDC 3000 System to a process control device through the Universal Control Network. A second NIM (optional), may be added to the system for redundancy.
- **Advanced Process Manager (APM):** Provides highly flexible I/O functions for both data acquisition and control.

One APM is supplied as standard with each Enhanced Micro TDC 3000 system. (For additional information on the APM see "Process-Connected Data Acquisition and Control.")

Functional Overview

The Enhanced Micro TDC 3000 system is designed on a global database concept. Data is kept in only one location; therefore, information displayed on two different USs is identical. This is true for other nodes as well.

The Enhanced Micro TDC 3000 system integrates information and control and makes available the data necessary for making operating and management decisions, through a single window. Enhanced Micro TDC 3000 systems satisfy a wide range of information and control requirements including the following items:

- Data acquisition
- A single window to the process
- Incremental levels of control
- Advanced control capability
- History collection
- Reporting
- Graphics
- Communication with a user-selected host computer
- Communication with programmable controller networks

More details on the functions provided by the Enhanced Micro TDC 3000 system can be found under the section headings "System Communication," "Information Processing and Advanced Control," and "Process-Connected Data Acquisition and Control."

System Configuration

The Enhanced Micro TDC 3000 system consists of a limited set of equipment and functions. Prebuilt configuration files are supplied to configure the network including the US, AM, HM, and NIM, along with one AM point, and one Area Database. Two USs and two NIMs are defined in the standard configuration file, but if only one of these pairs is actually present, the other will be shown as OFF on the status display. Prebuilt files and 15 APM points are supplied for the APM.

This document describes a standard, prebuilt system. If any options are implemented or any nonstandard configuration functions performed, file changes may be required.

System Communication

Local Control Network

The Twisted Pair Local Control Network (TPLCN) is the communication link between the nodes in Towers #1 and #2.

Functional Description

The TPLCN is similar to the LCN (Local Control Network) used in other TDC 3000 equipment, but a noncoaxial RS-485 (twisted pair) network has been chosen because of its simplicity and the short distances between nodes.

Distributed processing with centralized operations is a reality in Enhanced Micro TDC 3000 systems because the TPLCN provides rapid, secure communication between all modules. Information is transferred serially at 5 million bits per second. All modules are assured access to the network, even during a peak load.

Communication delays do not become excessive because a deterministic token-passing algorithm is employed to control access to the network.

Reliability

Dual cables, CRC verification on every received frame, and message-length checks by software ensure an extremely reliable network. Undetected errors are virtually nonexistent in an Enhanced Micro TDC 3000 system.

A 16-bit polynomial checksum in each information frame (sized from 100 to 2000 bytes) is used to check data transmission. If an error is detected, the frame will be retransmitted.

The TPLCN Interfaces in all modules have transmission and reception circuits for both twisted-pair cables. Should a cable, a transmitter circuit, or a receiver circuit fail, there is a backup to take over for it.

All modules residing on the TPLCN transmit all frames on both cables and normally "listen" on the active cable. If a TPLCN Interface does not hear anything on the active cable within the maximum interframe gap after receiving a

token pass frame, it switches its receiver to the backup cable.

Universal Control Network

The Universal Control Network (UCN), using the NIM, provides the communication link between UCN-resident modules such as the Advanced Process Manager and the Logic Manager (optional), and the TPLCN-resident modules such as a US, HM, AM, and Computer Gateway (optional).

Functional Description

The UCN is a high-speed, high-security, process control network. Based on IEEE 802.4 (ISO 8802/4) and extended message services, the UCN operates at a 5 megabit/second rate using efficient message structures to support the high-speed communications requirements of process devices.

UCN communications are consistent with the growth and direction of evolving international standards for Open Architecture and industrial specifications such as real-time MAP. The use of these standards facilitates future interconnection of multivendor devices.

Information from UCN devices (process status, configuration, etc.) is transferred through the NIM to the TPLCN. This data is used for the Micro TDC 3000 operator, control, history, and management functions.

Commands and configuration information for data points are transferred from the TPLCN through the NIM to the UCN.

The UCN supports peer-to-peer communications. This means that UCN devices can write data to and read data from other UCN devices for additional control strategy, flexibility, and coordination.

Reliability

The use of dual cables, 32-bit CRC frame-check sequence

verification on every received frame, and message-length checks by the software ensure an extremely reliable network. Detected errors can be corrected by a repeat transmission from the sending device.

The UCN interfaces in all modules have transmission and reception circuits for both coaxial cables. The transmitter and receiver circuits are transformer-coupled to provide electrical isolation between the modules on the network. They are designed so that a circuit failure cannot affect the operation of the cables or other devices connected to the UCN. Additional protection against individual device faults is provided by cable taps that isolate the drops and devices from the trunk cable.

A second level of security is built into each network device in the form of diagnostic software that monitors and reports numerous device and parameter error conditions. These checks assure a high-performance, real-time network with message security.

To verify its ability to communicate over the UCN, each device continually performs a set of diagnostic tests to determine the status of the two cables. This includes periodic switching of cables and monitoring each cable for noise interference or silence, which would indicate that a failure has occurred. Each device also monitors itself for excessive, continuous transmission, and shuts down its own modem if that condition is detected.

Network Interface Module

The NIM provides the communication link between the TPLCN (Twisted Pair Local Control Network) and the UCN.

Functional Description

The NIM makes the transition from the transmission technique and protocol of the TPLCN to the transmission technique and

protocol of the UCN. The NIM provides TPLCN modules access to data from UCN-resident devices, such as Advanced Process Manager, Process Manager, and Logic Manager. Alarms and messages are forwarded from these UCN devices to TPLCN-resident devices such as USs, HMs, AMs, and Computer Gateways (optional).

Process-Connected Data Acquisition and Control

The Enhanced Micro TDC 3000 system incorporates Honeywell's most powerful advance in data acquisition and control devices, the Advanced Process Manager (APM).

Advanced Process Manager

The field I/O devices are connected to the APM through Field Termination Devices. See Figure 3 for details. The APM is a fully integrated member of the TDC 3000^X family capable of:

- Performing data acquisition and control functions, including regulatory, logic, and sequential control functions, as well as peer-to-peer communications with other UCN devices.
- Providing bidirectional communications to ModbusTM and Allen-BradleyTM compatible subsystems through a serial interface.
- Fully communicating with operators or engineers at Universal Stations. Procedures and displays are identical or similar to those for other TDC 3000^X controllers. Plant personnel may already be familiar with them.
- Supporting higher level control strategies available on the Local Control Network through the Application Module and host computers.

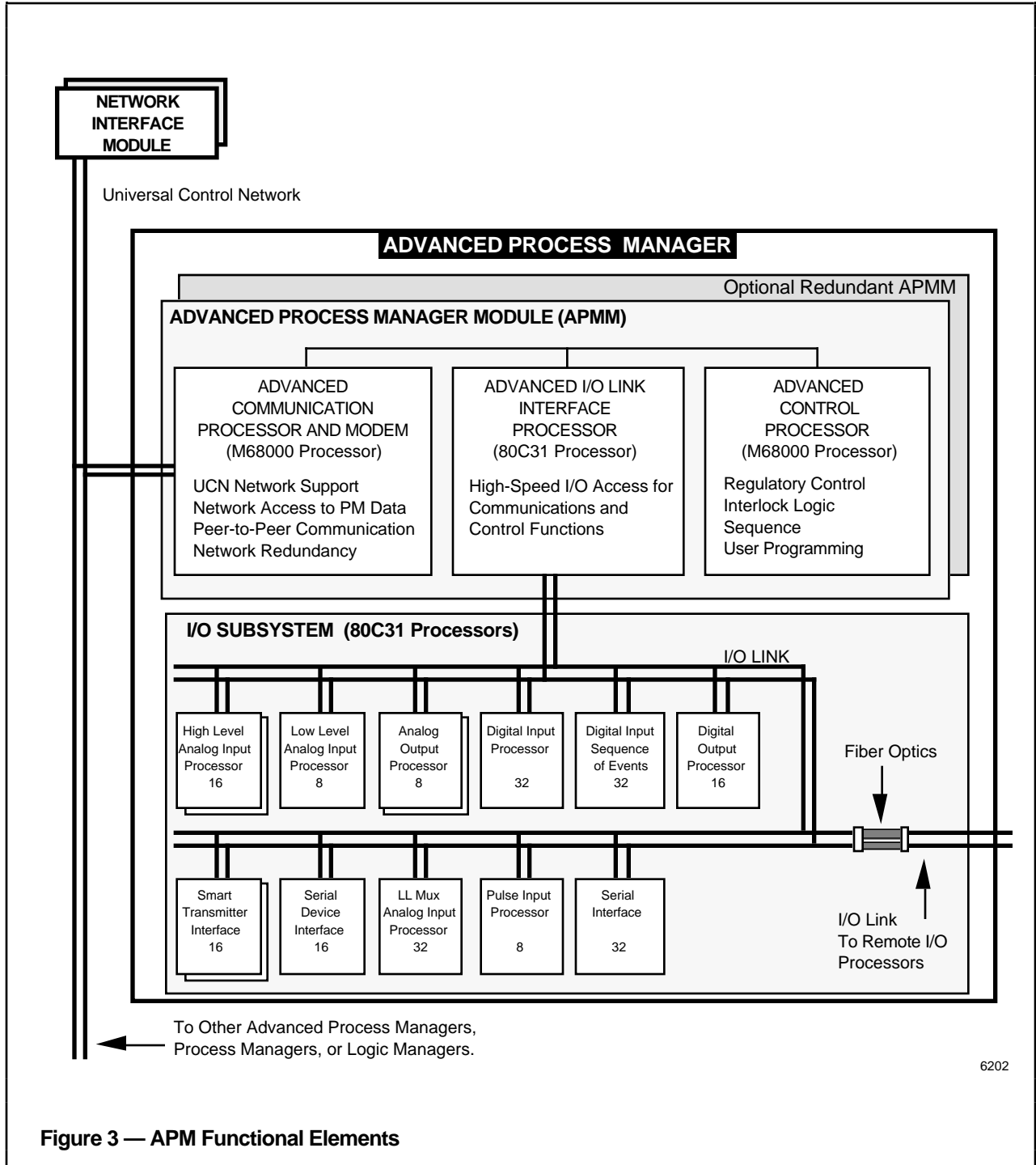

Figure 3 — APM Functional Elements

Functional Description

The Advanced Process Manager provides flexible and powerful process scanning and control capabilities. To do this, it uses an advanced multiprocessor architecture with separate microprocessors dedicated to perform specific tasks. As depicted in Figure 3, the APM consists of the Advanced Process Manager Module (APMM) and the I/O Subsystem.

The APMM consists of an Advanced Communication Processor and modem, an Advanced I/O Link Interface Processor, and an Advanced Control Processor.

The Communication Processor is optimized to provide high-performance network communications, handling such functions as network data access and peer-to-peer communications. The Advanced Control Processor is the APM resource dedicated to executing regulatory, logic, and sequence functions, and includes an excellent user programming facility. The Advanced I/O Link Interface Processor is the APMM interface to its I/O subsystem. A redundant APMM can be optionally provided.

The I/O Subsystem consists of the redundant I/O Link and up to 40 I/O Processors. These I/O Processors handle all field I/O for both data acquisition and control functions. The IOPs provide such functions as engineering unit conversion, alarm limit checking, etc.

APM Control Functions

The APM provides a variety of control tools to address a wide range of process automation needs.

All I/O values are initially converted to engineering units by the I/O Processors and made available for both communications and further control processing by the APMM. Conceptually, the APMM can be thought of as partitioned into configurable "slots" of various types. A tagged slot is called a **data point**. In an Enhanced Micro TDC 3000 system, data points are supported by predefined group and detail displays and by custom graphics.

The following types of data points (descriptions follow) can be configured into APMM slots:

- Regulatory PV
- Regulatory Control
- Digital Composite
- Logic
- Device Control
- Process Module
- Array
- Flag
- Numeric
- Timer
- String
- Time

Prebuilt APM Points

Configuration files provide 15 APM points of several different types. These prebuilt APM points can be used as models for building additional APM points.

APM Regulatory PV Point

Regulatory PV points provide an easy-to-use configurable method for implementing Process Variable (PV) compensation and calculation functions. See Table 1 for a list of the available algorithms.

Table 1 — APM Regulatory PV Points

Available Algorithms
Data Acquisition Flow Compensation Middle-of-3 Selector High/Low/Average Selector Summer Totalizer Variable Dead Time with Lead/Lag General Linearization Calculator

APM Regulatory Control Point

Configurable regulatory (or analog) control functions are performed using Regulatory Control points. Regulatory Control points are configured to execute one of the control algorithms listed in Table 2.

Each algorithm includes a wide range of configurable options to allow implementation of complex control strategies by a simple menu-selection process. In addition, some functions such as initialization and windup protection are inherently provided. The capability to ramp setpoint (by operator entry of a target value and ramp time) is configurable. A number of standard and custom graphic displays are available to support these control strategies.

Table 2 — APM Regulatory Control Data Points

Available Algorithms
PID PID with Feedforward PID with External Reset Feedback PID with Position Proportional Position Proportional Ratio Control Ramp Soak Auto/Manual Station Incremental Summer Switch Override Selector

APM Digital Composite Point

Digital Composite points are multi-input/multi-output points that provide an interface to discrete devices, such as motors, pumps, solenoid valves, etc. This point provides built-in structures for handling interlocks. In addition, provision is made for handling manual/off/auto switches commonly used for local operation of motorized devices. It supports operator display of interlock conditions in group, detail, and graphic displays. Displays also contain information needed to trace interlock cause. Runtime maintenance statistics for the discrete device are also supported.

APM Logic Point

APM Logic points provide a configurable mix of logic block algorithms that together with digital composite points provide the basis for integrated interlock logic functions. See Table 3 for a list of the logic block algorithms.

Table 3 — APM Logic Block

Available Algorithms
Logic
Compare Real
Delay
Pulse
Watchdog Timer
Flip-Flop
Check for Bad
Switch
Change Detect

Conceptually, a Logic point can be thought of as providing the logic processing equivalent to one or two pages of relay ladder logic. A Logic point consists of logic blocks, flags, numerics, input connections, and output connections. Different mixes of inputs, outputs, and logic blocks can be optionally selected.

APM Device Control Point

The APM Device Control point provides maximum flexibility for controlling discrete devices. It combines the digital composite display and logic control function under a single tagname. This provides an enhanced interface for pumps, motors, and motor operated valves.

The Device Control point's single tagname enhances the operator interface for motor control points. Operations are improved because the operator can see the cause of the interlock. An analog feedback signal such as motor control current is displayed. Implementation effort is also reduced through the use of a simple configuration and standard graphics for troubleshooting.

Process Module Point – User Programs

Today's control strategies frequently need the flexibility of user programs that can be used for continuous, batch, or hybrid applications.

A Process Module point is a resource for executing user programs written in Honeywell's Control Language (CL/APM, an enhanced version of CL, the Control Language used by Honeywell in the AM). CL/APM is an outstanding sequential control and computational tool. CL/APM programs are self-documenting—an important feature when future modification of control strategies is anticipated. Using the US, programs can be easily modified and reloaded without affecting execution of regulatory control, logic blocks, or other user programs.

All process module programs can communicate through the common system database to access analog inputs and outputs, digital inputs and outputs, array points, logic block states, alarm states, failure states, numeric variables, and flags.

CL/APM programs can also manipulate ASCII values as well as time data. In addition, each process module program supports communication with the operator and can send or receive data from other controllers on the UCN.

Process Module points provide a Phase/Step/Statement structure that is well-suited for implementing batch process control functions. Additionally, a multilevel abnormal event-handling capability allows the user to define conditions to automatically trigger predefined Hold, Shutdown, or Emergency Shutdown sequences.

APM Array Point

The Array point provides a flexible, easy-to-access point structure for user-defined data. It is especially useful for advanced control or batch sequence programs. For example, an Array point can be used to store calculation variables or batch recipe data.

The Array point can also be used for Serial Interface (SI) communications to third party subsystems, such as programmable logic controllers. Communication to a Serial Interface Array point is fully bidirectional. Data from any Serial Interface Array point can be accessed by other APM control and CL functions such as Device Control points. This allows subsystem data to be used for APM data acquisition and control strategies, as well as displayed at the Universal Station.

APM I/O Functions

The I/O Processors (IOPs), along with Field Termination Assemblies (FTAs), perform input and output scanning and processing on all field I/O (Figure 3). I/O link redundancy provides added security. Redundancy is also available for some IOPs. I/O processing is separate from control processing, so that I/O scan rates are entirely independent of I/O quantity, controller loading, processing,

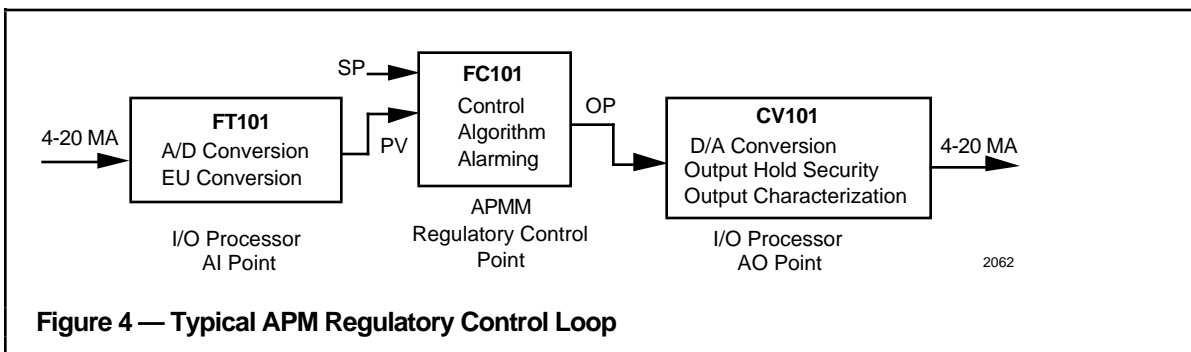

and alarming. This partitioning of functions allows more efficient use of APM capability and provides for I/O expansion.

A variety of I/O Processors are available for the APM:

- Analog Input –
 - High Level (16 points)
 - Low Level (8 points)
 - Low Level Multiplexer (32 Points)
- Smart Transmitter Interface (16 points)
- Analog Output (8 points)
- Serial Device Interface (16 points, 2 ports)
- Serial Interface (32 arrays, 2 ports)
- Pulse Input (8 points)
- Digital Input (32 points)
- Digital Input Sequence of Events (32 points)
- Digital Output (16 points)

Any mix of the above IOPs can be selected for an APM. This can be any combination of single and/or redundant (HLAI, STI, and AO) pairs, up to a total of 40. In a redundant configuration, control automatically transfers to the backup I/O processor during board replacement.

While more than one FTA is required to handle varying field wiring signal levels, the same I/O Processor can be used for a number of different sensors. For example, one Digital Input Processor can handle 24 Vdc, 120 Vac, or 240 Vac. This

approach simplifies system hardware selection and minimizes spare parts requirements.

APM Alarm System Functions

As process alarms occur, they are visually annunciated at the Universal Station through keyboard LEDs and numerous types of displays such as custom graphic displays, group displays, alarm annunciator displays, alarm summaries etc.

There are four different process variable alarms and three different digital alarms. All PV alarms have a selectable deadband. Contact cutout is another configurable feature provided by the APM to automatically suppress alarm reporting if certain external conditions occur.

APM Control Implementation

A simple control loop can be implemented in an APM, using an analog input point, a regulatory control point, and an analog output point, as shown in Figure 4.

Although three data points are used, the primary operator interface is a single tag (FC101) for viewing, alarming, and manipulation through a Group, Detail, or Custom Graphic Display.

APM Control Performance

The parallel processing architecture of the APM allows its control processing capability to be totally independent of other APM functions such as the number of I/O points built, data requests for

APM data from the Network Interface Module and other UCN devices, and alarming functions. Only two factors need to be considered when configuring the control processing—the **type** of control points (slots) desired and their **frequency** of execution or scheduling interval.

Processing power is measured in terms of "Processing Units" (PUs). Each control processor has an assured rate of 160 PUs per second. Regulatory, logic and digital composite, and device control points can be configured at different execution frequencies (1/4, 1/2, or 1 second).

Any mixture of point types can be used, subject to the following maximums:

- 160 Regulatory Control
 - 80 Regulatory PV
 - 80 Logic
 - 512 Digital Composite
 - 160 Device Control
 - 160 Process Module (@ 1 PU per APM program)
- OR—
- 80 Process Module (@ 2 PUs per APM program)

APM Security

The Advanced Process Manager has a number of security features to provide maximum process availability. A high reliability, fault-tolerant approach to the circuitry and the overall system architecture has been used throughout the APM's design. CMOS technology, including

highly heat-tolerant components, is used to provide a high-density design with high reliability.

Individual circuitry is used for critical functions, such as D/A converters on the output circuitry. Parallel power paths are employed so that control outputs can be maintained even if a power regulator fails.

Since redundancy options are designed into the product, automatic switchover from primary to redundant electronics is fully supported. No special user programming is required.

Ongoing diagnostics are provided to assure both primary and redundant electronics are functional. This one-on-one approach enhances coverage to maximize availability. It also simplifies system cabling and configuration.

Repairs to the APM can be made easily by replacing boards while power is on. Analog and Digital Standby Manual Units are available to maintain process outputs during board replacement.

Overall, the APM provides superb control capabilities with excellent process control availability and security.

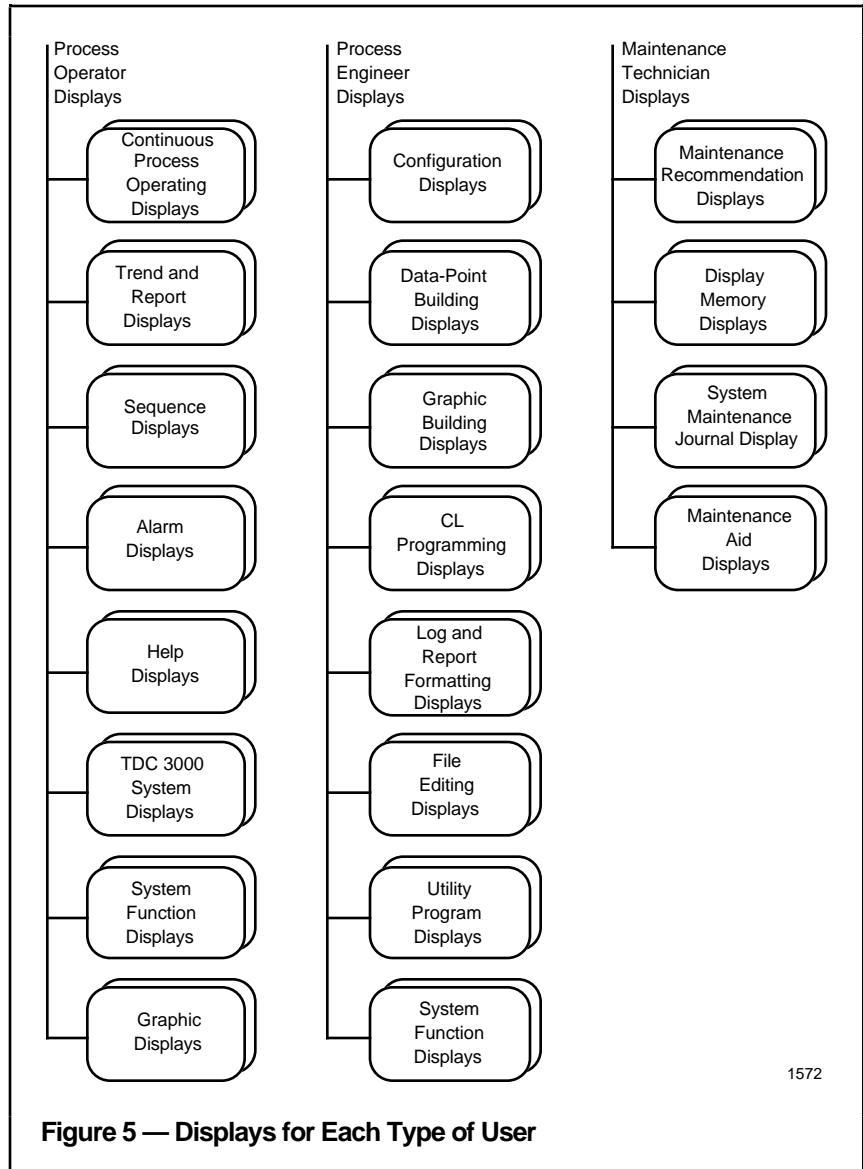

Figure 5 — Displays for Each Type of User

Information Processing and Advanced Control

In the Enhanced Micro TDC 3000 system, information processing and advanced control functions are distributed into discrete modules which provide:

- A single window for access to the system by all types of users.
- The information-processing and storage facilities to support that access.
- A comprehensive set of standard control algorithms together with the ability to create custom algorithms and processing routines.

Universal Station

The Universal Station (US) communicates with the other modules on the TPLCN, and with process-connected devices on the UCN using the NIM.

Display Summary

The process operator, process engineer, and maintenance technician communicate with the process and the system using a variety of CRT displays. They view the displays and then either make keyboard entries or select a target on the display. Entries can be made on the operator's or engineer's keyboard, depending upon the function. Figure 5

shows the three basic US display types.

Process Operating Functions

The operator can access all the data needed for normal plant operation from the US using the operator's personality. This data is presented in displays ranging from a broad overview to the most detailed information at the data point level.

The Enhanced Micro TDC 3000 system provides the following process operating functions:

- Load other system modules and process-connected

devices with data from the HM or a cartridge.

- Reassign USs, area database, units, and peripherals.
- Initiate on-demand checkpointing.
- Review data point assignments of system modules, process-connected devices, and units.
- Monitor and control continuous and discontinuous processes.
- Monitor the status of TPLCN and UCN modules and process-connected devices.
- Change process parameters, control modes, sequence-execution states, and modes.
- Annunciate process, sequence, system alarms, and operator messages.
- Display and print process trends, averages, and histories.
- Display and print reports, logs, and journals.
- Edit Overview and Group displays.

Process Engineering Functions

In the engineering mode, the US provides a user-friendly environment for the process engineer to build or modify the database needed to meet his process objectives. A Help facility is available to assist with system data entry for point, display, and report building, etc.

The Enhanced Micro TDC 3000 system provides the following process engineering functions:

- Configure the network
- Load operating programs and databases from the HM or a cartridge.
- Build the process and system databases.
- Build data points.
- Custom build and load graphic displays, reports, and logs.
- Prepare, edit, compile, and link CL programs.
- Edit source files

- Call up System Function displays.
- Load Honeywell-supplied software updates.

Maintenance Functions

In the engineering personality, the maintenance technician can diagnose problems in the TPLCN-based modules, the UCN, and UCN-connected process devices.

When faults occur in an Enhanced Micro TDC 3000 system, they are usually isolated by built-in tests and diagnostics that are executed during startup, restart, and on-process operation. The fault is usually isolated to an optimum replaceable unit, and a maintenance recommendation is issued.

The maintenance functions provided are as follows:

- Call up maintenance recommendation displays.
- Display and print information required for troubleshooting.
- Call error detail of a failed node.

Standard Displays

For an Enhanced Micro TDC 3000 system, the standard Area Database configuration file provides the following displays and journals:

- Group Displays (2)
- Unit Trend Display
- System Status Display
- Reports (2)
- Process Module Group Displays (3)
- Unit Summary Display
- Annunciator Display
- Process Journals (3)
- System Journals (3)
- Real-Time Journal
- Overview Display
- Area Trend Display

Application Module

The Application Module (AM) communicates with other modules on the TPLCN and with process-connected devices on the UCN. It performs high-level calculations and control strategies not possible or practical using only process-connected devices.

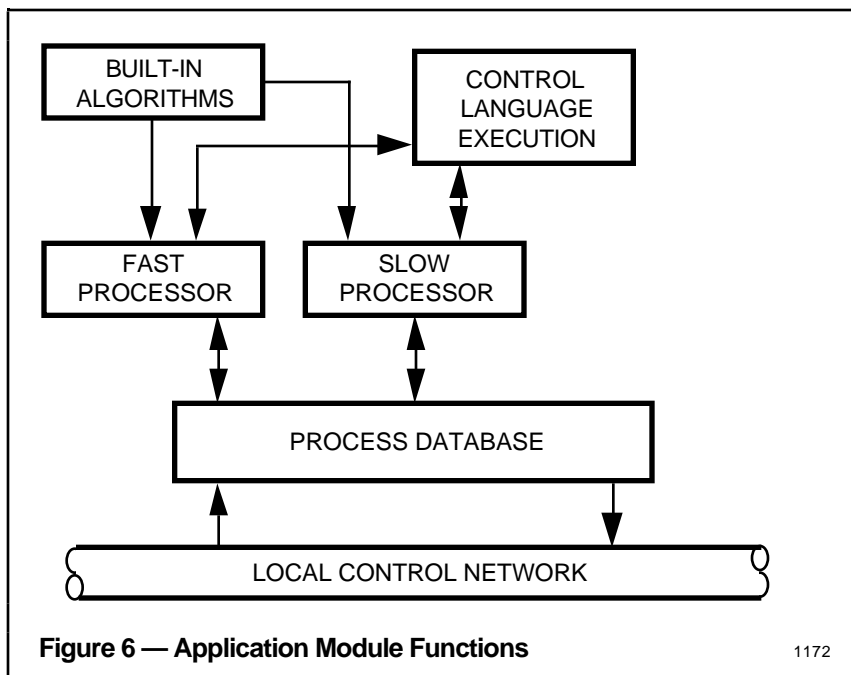

Figure 6 — Application Module Functions

Functional Description

Control strategies in the AM can be implemented with standard algorithms and standard data point processing, or with custom algorithms and custom processing routines implemented through the AM Control Language.

See Figure 6 for a description of the major AM functions.

Prebuilt AM Regulatory Point

Configuration files are provided for one AM regulatory point. Additional AM regulatory points can be built by copying this master point and changing only those parameter values which are different.

AM Data Points

The AM contains a process database made up of data points that the process engineer loads during configuration. Each data point is a collection of fixed and dynamic parameters that performs a specific function and is identified by a point name. Data point processing can use predefined or custom algorithms to calculate required information and/or initiate specific control action.

In addition to regulatory data points that represent continuous process variables, the AM also offers several utility data point types such as timers, counters, flags, and numerics.

AM Data Point Scheduling

Each data point in an AM is processed according to a schedule defined by the process engineer during system configuration. The engineer may assign a data point to either a "fast" or a "slow" processor and may choose from a variety of time intervals ranging from 1 second to 24 hours. The fast processor has a higher priority. The engineer can also schedule data points to be processed before or after another data point, on demand, or when some user-defined process event occurs.

AM Regulatory Control

General Input Processing – At the user's option, a regulatory data point can fetch values from the process database and update designated parameters within the data point before proceeding with the remainder of its processing.

PV Processing – A regulatory data point that uses PV processing fetches designated PV inputs from a process-connected module on the UCN before executing the specified PV algorithm (see Table 4), or custom algorithm. The PV is calculated, limit checked, and a value status (good, bad, or uncertain) is assigned.

Table 4 — AM PV Algorithms

Algorithm Name
Null
Data Acquisition
Flow Compensation
Middle-of-Three Selector
Hi/Lo Average Selector
Summer
Multiplier/Divider
Sum of Products
Variable Dead Time with Lead-Lag
Totalizer
General Linearization
CL PV Algorithm

Control Processing —A regulatory data point that uses control processing obtains the designated control inputs from PV processing, or elsewhere, before executing the selected control algorithm (see Table 5), or custom algorithm.

Table 5 — AM Regulatory Control Algorithms

Algorithm Name
Null
Auto Manual
PID with Options, including GAP, Nonlinear Gain, Auto-Ratio, Auto-Bias
PID with Ext. Reset Feedback
PID with Feedforward
Incremental Summer
Lead/Lag
Summer
Multiplier/Divider
Ratio
Override Selector
Switch
Ramp Soak
CL Control Algorithms

Such a data point can also be configured to store the output in other data points in the same AM or in some other process-connected device.

AM Control Output Processing – Control output processing stores a whole value appropriate to the units of the destination parameter. It also accommodates any control constraints, including output high/low limits, output increment limits, and integral high/low limits, as well as handling initialization, mode change, and antiwindup conditions.

AM Alarming – If an alarm is detected as a data point and is processed, the event is journaled, annunciated, and displayed in the same way as an alarm detected by a process-connected device.

AM Custom Control

In addition to the built-in PV and control algorithms, the engineer may use Control Language (CL) to define his own algorithms and processing routines. Programs are written, edited, and compiled at a US.

Control Language – CL is designed specifically for the process engineer to use in implementing custom control schemes. This easy-to-use language employs a variety of general and process-oriented statements. See Table 6 for a list of the CL statements.

Custom Data Segment – A Custom Data Segment (CDS) is a structure that provides the capability to define one or more parameters that can be accessed by CL programs. Once defined and attached to a specific data point, the CDS is available for displays and other functions.

CL Insertion Points – Predefined insertion points in the standard processing sequence make it simple for the user to insert a block of CL code to be executed when a specific event occurs (for example, an alarm threshold is crossed).

CL Algorithms – The standard sets of PV and control algorithms have "Control Language algorithm" as one of the choices, making it easy for the user to substitute his own algorithm in the normal point-processing procedure.

Custom Multipoint Switch – A CL switch data point can be used with user-written CL routines to monitor and direct control of strategies that involve different sets of data points. The multipoint CL routines respond to strategy changes requested by the process operator through a US.

History Module

The History Module (HM) communicates with other modules

Table 6 — Control Language for the AM

Data Types			
Number Strings	Time Arrays	Data Points	Discrete (Logical, Enumeration)
Statements			
set	go to	call	state change
send	if/else	loop	repeat
exit	abort	end	
Operators			
Arithmetic	-, +, *, /, mod, **		
Logic	and, or, not, xor		
Relational	<, +, >, <+, >+, <>		
Functions and Subroutines			
Abs, Atan, Avg, Cos, Exp, Int, Ln, Log10 Max, Min, Round, Sin, Sqrt, Sum, Tan			
Allow_Bad	Badval	Comm_Error	Date_Time
Exists	Len	Now	Number
Self	Set_Bad		

on the TPLCN and with process-connected devices on the UCN.

Functional Description

The HM serves as a system-wide, multi-use mass storage device. This stored information is available to any module on the TPLCN. Information from process-connected devices can be stored on the HM. The major elements of the HM are shown in Figure 7.

The HM can be configured to store the following items:

Continuous process history

- Sample data
- Averages

Event history

- Process events
- TDC 3000^X system events

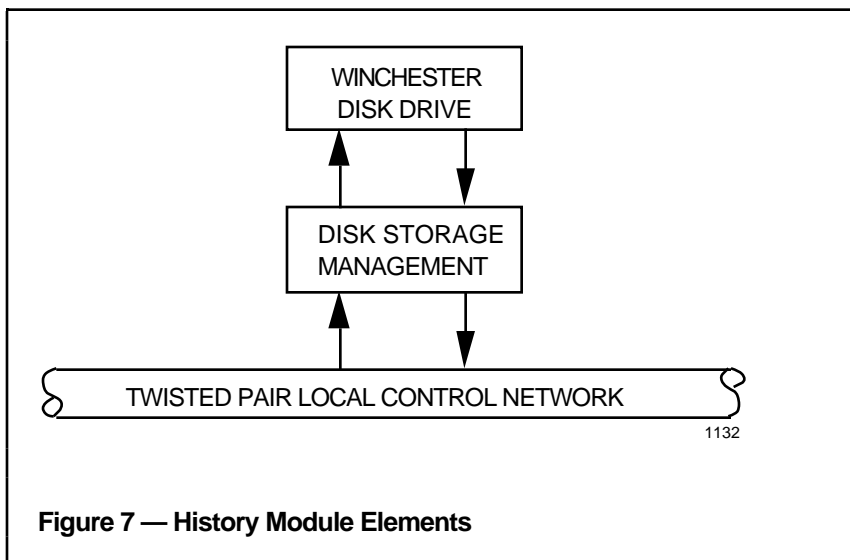

Figure 7 — History Module Elements

Active system files

- Graphic display abstracts
- Database checkpoints
- User files (e.g., CL)
- System configuration files

Static system files

- Software images

On Process Analysis program

- Maintenance aid

The HM is loaded, configured, and initialized at the factory with the standard Enhanced Micro TDC 3000 volumes, directories, and database. A prebuilt Network Configuration File (NCF) is supplied with the system. The user can reconfigure the NCF to suit his specific needs.

Continuous Process History

The HM is configured (in the NCF) to store continuous history. The values for 10 units (with 10 groups per unit) are collected once a minute and used to calculate various types of averages.

The following base averages are maintained:

- Hourly averages for 1 week
- Shift averages for 1 week
- Daily averages for 1 month
- Monthly averages for 1 year

Discrete data samples ("snapshots") and user averages (over 6 minutes periods) are computed and saved for 168 hours (1 week) for "snapshot" data, and 336 hours (2 weeks) for user averages.

Event History

Event history is also stored in the HM. Event history consists of process alarms, operator process and system changes, operator messages, and the system error and maintenance journals. The last 1400 events are kept for each of the 10 units.

Display Abstracts

Space is allocated to store display abstracts (everything except the dynamic information) on the HM.

Loadable Software Images

Software images are stored on the HM instead of a cartridge disk to facilitate loading.

Database

Information on the data content of the modules on the TPLCN and UCN is stored in the HM. It can be quickly uploaded (checkpointed) and downloaded using simple operator commands. This database storage is used each time a point-owner module (AM, NIM, PM) is reloaded.

On Process Analysis Program

This program performs periodic analysis of the accumulated errors for each TPLCN module and issues recommendations for hardware replacement if a predefined error-frequency limit is exceeded.

These recommendations are displayed on the US and entered in the maintenance journal.

System Peripherals

- **Touchscreens or Trackballs:** Touchscreens or trackballs are optional peripherals that allow the user to "point" to areas on a display and select operations to be performed. (Without a touchscreen or trackball, the user must use the directional arrows on the keyboard to navigate across the screen.)
- **Engineer's Keyboard:** An additional engineer's keyboard is an option on any added US.
- **Printer:** A second printer is an option on an Enhanced Micro TDC 3000 with two or more USs.

Optional TPLCN Nodes

Additional TPLCN nodes (up to the maximum total of eight nodes per Enhanced TDC 3000 System) may be added to the towers.

The following system expansion nodes are available:

- **Universal Station:** Provides additional windows to the process. Up to a total of four USs maybe installed in an Enhanced Micro TDC 3000 system. The additional USs can support either "Operator" personality or "Universal" personality.
- **Redundant Network Interface Module (NIM):** Provides a second path to the process devices in the event of a primary failure.
- **Computer Gateway:** Provides a path to a host computer.
- **Plant Network Module:** A dedicated interface to a Digital VAX or AlphaAXP host computer, supporting bidirectional data transfer between the Enhanced Micro TDC system and OpenVMS-based applications.
- **Network Gateway:** Enables an Enhanced Micro TDC 3000 system to be linked to either another Enhanced Micro TDC 3000 or a TDC 3000^X LCN at a different location. Bidirectional transfer of data between the Enhanced Micro TDC 3000 system and the other system allows plantwide information to be integrated and accessed at a single window. Communications are effected via carrierband or fiberoptic links (optional), with a Network Gateway at each end of the link.

- **Programmable Logic Controller Gateway:**

Provides a path to one or more Programmable Logic Controllers.

References

See the following Specification and Technical Data publications:

AM03-400 - Application Module
CG03-400 - Computer Gateway
HM03-400 - History Module
LC03-400 - Local Control Network
*PL03-400 - Programmable Logic
Controller Gateway*

PM03-400 - Process Manager
US03-400 - Universal Station
LM03-400 - Logic Manager
*See also MT11-420 (8-Node
Enhanced Micro TDC 3000
User's Manual) and MT13-420
(8-Node Multinode Module
Service).*

Specifications

Physical Characteristics

	<u>Approximate Dimensions</u>		<u>Approximate Weight</u>
Electronics Tower (each)	Height	72 cm (28.5")	45 kg (100 lb)
	Width	32 cm (12.5")	
	Depth	58 cm (22.8")	
Printer	Height	17 cm (6.7")	14 kg (30 lb)
	Width	62 cm (24.2")	
	Depth	31 cm (12.2")	
Color Monitor (21")	Height	47 cm (18.5")	33 kg (73 lb) net
	Width	49 cm (19.4")	
	Depth	54 cm (21.1")	
Advanced Process Manager (Single-Access)	Height	201 cm (79")	113 kg (250 lb) max.
	Width	80 cm (31.5")	
	Depth	50 cm (19.7")	
Twisted Pair Local Control Network	Type	RS-485 Twisted Pair (noncoaxial)	
	Length	Between towers; 1.5 m (5 ft) standard; 10 M (33 ft) optional (max.)	
	Modules	Up to 4 modules per tower (8 max.)	
Universal Control Network	Type	Trunk Cable	RG-11, quad shield with inner and outer foil and braid shields, and PVC flame-retardant jacket
		Drop Cable	RG-6 quad shield
	Length	Trunk Cable	Depends on number of drops (refer to <i>Site Planning/Universal Control Network</i> manual)
		Drop Cable	Up to 50 meters

Operating Characteristics

Universal Station (K2LCN-4 Mw processor)*

* K2LCN-4 Mw processors are standard on the Universal Stations supplied with the base system models. This supports the "Universal" personality. Universal Stations with K2LCN-3 Mw processors that support only the "Operator" personality are also available as a system expansion option.

	<u>Display Type</u>	<u>Call-up Times (typical)</u>
Primary Operating Displays	Group	1.5-2 seconds
	Detail	4-6 seconds
	Trends	8-20 seconds
	Alarm Summary	1-2 seconds (first value update in 10 secs)
System Monitoring/ Maintenance Displays	Status	1-3 seconds
	Point Summary	2-20 seconds
Graphic History (100-150 parameters)	US-resident	3-5 seconds
	HM-resident	3-6 seconds

Display Capacities

Point Detail Display: All points in the system
Operating Group Display: 450 (400 standard + 50 Process Module)

Specifications

Operating Characteristics (continued)

Universal Station (continued)

Display Capacities

Graphic Display	Limited only by available storage capacity, including US, HM, and Cartridge disks.	
Color Monitor	Resolution	1600 x 1280 pixels (noninterlaced)
Cartridge Disk Drive (5 1/4 in. disk)	Memory Capacity	21,417,894 bytes
	Data Transfer Rate	500 kbits per second
Printer	Desk top, 132 column, tractor feed (continuous sheet) dot matrix printer, 250 cps	

Application Module (K2LCN-2 Mw or K2LCN-8 Mw processor, depending on base system model purchased).

Point Processing Capacity	Up to 120 data points per second, depending on point type.	
Data Point Capacity	Varies widely with point type and memory usage. See <i>Engineer's Reference Manual</i> for details.	
Point Scheduling Capacity	Fast Processing	1 sec, 2 sec, 5 sec, 10 sec, 15 sec, 30 sec, 1 min, 2 min, and on demand
	Slow Processing	1 min, 2 min, 5 min, 10 min, 15 min, 30 min, 1 hr 8 hr, 12 hr, 24 hr, and on demand

History Module (K2LCN-2 Mw processor)

Memory Capacity	445 megabytes (exactly 443.486 megabytes)* (* 1 megabyte = 1,024 kilobytes = 1,048,576 bytes)
Data Transfer Rate	4.84 megabytes per second
Average Latency Time	6.61 msec
Average Seek Time`	11.25 msec (typical)
Watts (maximum)	7 Watts
Non recoverable Read Errors	<1 per 10 ¹⁴ bits transferred
Error Detection and Recovery	Retries, generation, and checking of checkcodes, correction of burst errors of up to 48 bits.
Seek Error Rate	<1 per 10 ⁷ physical seeks
Unrecoverable Error Rate	One in 10 ¹² bits transferred or less

Specifications

Operating Characteristics (continued)

Network Interface Module (K2LCN-2 Mw processor)

Point Capacity	Up to 8000 points
Data Access	1200 single parameters per second

Power Options

Electronics Tower	Voltage	120, 240 Vac +10%, -15%
	Frequency	47 Hz to 63 Hz
Process Manager	Voltage	120, 240 Vac +10%, -15%
	Frequency	47 Hz to 63 Hz

Environmental

The Micro TDC 3000 Control System is designed for a Class C (office) environment. It must be operated in a temperature environment of 0°-45°C (32°-113°F). While operating, components of this system are not designed to withstand greater vibrations than:

5-22 Hz	0.254 mm (0.010 inch) displacement
22-500 Hz	0.25 g

Copyright, Trademarks, and Notices

The following are trademarks of Honeywell Inc.:

TDC 3000^X system

The following are trademarks of their respective companies or organizations:

Modbus
Allen-Bradley

All other brand or product names appearing herein are trademarks of their respective companies or organizations.

While this information is presented in good faith and believed to be accurate, Honeywell disclaims the implied warranties of merchantability and fitness for a particular purpose and makes no express warranties except as may be stated in its written agreement with and for its customer.

In no event is Honeywell liable to anyone for any indirect, special or consequential damages. The information and specifications in this document are subject to change without notice.