

Process Manager/ Advanced Process Manager Planning

PM02-501

System Site Planning - 1

***Process Manager/
Advanced Process
Manager Planning***

**PM02-501
CE Compliant
Release 500
3/96**

Copyright, Notices, and Trademarks

Printed in U.S.A. – © Copyright 1995 by Honeywell Inc.

Revision 03 – March 1, 1996

While this information is presented in good faith and believed to be accurate, Honeywell disclaims the implied warranties of merchantability and fitness for a particular purpose and makes no express warranties except as may be stated in its written agreement with and for its customer.

In no event is Honeywell liable to anyone for any indirect, special or consequential damages. The information and specifications in this document are subject to change without notice.

TDC 3000 is a U. S. trademark of Honeywell Inc.

Process Manager is a U. S. trademark of Honeywell Inc.

SMARTLINE is a U. S. trademark of Honeywell Inc.

Other brand or product names are trademarks of their respective owners.

Honeywell
Industrial Automation and Control
Automation College
2820 West Kelton Lane
Phoenix, AZ 85023
(602) 313-5669

About This Publication

This manual provides information necessary to properly plan the installation of a Process Manager (PM) or Advanced Process Manager (APM) subsystem at a TDC 3000^X system site. The subsystem encompasses the Process Manager and/or Advanced Process Manager and the Network Interface Module (NIM), which is resident on the Universal Control Network (UCN), a network associated with the TDC 3000^X Local Control Network (LCN). The amount of information that this publication provides depends on your personal experience and the process that the Process Manager or Advanced Process Manager will control and monitor.

The experienced planner, a person involved in the installation of TDC Basic or LCN equipment, will find that some information is familiar. Regardless of your past experience, you must read Section 4 in this manual to enhance your knowledge of the process control connections available, and also reference the *TDC 3000^X System Site Planning*, *Universal Control Network Planning*, and *Universal Control Network Installation* manuals to prepare yourself for the connection of the Process Manager or Advanced Process Manager to the Universal Control Network.

In some cases, control room expansion will be part of installing the Process Manager or Advanced Process Manager. If this is the case, use the *Local Control Network Planning* and *Local Control Network Installation* manuals to plan for expansion of the network.

Both non-CE Compliance and CE Compliance are addressed in this publication. Differences are noted in the hardware and installation practices when applicable. Section 7 is devoted to CE Compliance and should be referenced.

This publication supports software Release 500.

This publication supports CE Compliant equipment. Any equipment designated as “CE Compliant” complies with the European Union EMC and its health and safety directives. All equipment entering the European countries after January 1, 1996 require this type of compliance, denoted by the “CE Mark.”

Standard Symbols

Scope

The standard symbols used in this publication are defined as follows.

ATTENTION

Notes inform the reader about information that is required, but not immediately evident.

CAUTION

Cautions tell the user that damage may occur to equipment if proper care is not exercised.

WARNING

Warnings tell the reader that potential personal harm or serious economic loss may happen if instructions are not followed.

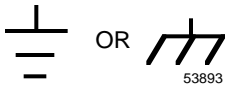

Ground connection to building safety ground.

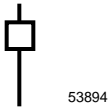

Ground stake for building safety ground.



Electrical Shock Hazard—can be lethal.



Electrical Shock Hazard—can be lethal.

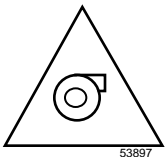

Rotating Fan—can cause personal injury.

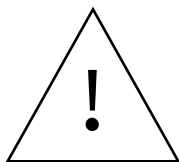

Caution—refer to the appropriate installation document.

Table of Contents

SECTION 1 – INTRODUCTION.....	1
1.1 Overview.....	1
SECTION 2 – PM/APM DESCRIPTION.....	3
2.1 Overview.....	3
2.2 Card Files.....	5
2.2.1 PMM/APMM Card Files.....	5
2.2.2 Input/Output Processor (IOP) Card File.....	12
2.3 Input/Output Processors (IOPs).....	13
2.3.1 IOP Redundancy.....	14
2.4 I/O Link Extender (Fiber Optic Link).....	16
2.5 Field Termination Assemblies (FTAs).....	21
2.6 Power Systems.....	32
2.7 Cabinet Configurations.....	37
SECTION 3 – POWER REQUIREMENTS.....	41
3.1 Overview.....	41
3.2 Backup Strategy.....	42
3.3 Quality.....	44
3.4 Power Draw.....	47
3.4.1 Typical 24 Vdc Power Draw Calculations.....	48
3.4.2 Single Power System Calculation Example.....	53
3.4.3 Dual Power System Calculation Example.....	54
3.4.4 PM/APM AC Power Draw.....	55
3.4.5 Crest Factor.....	57
3.4.6 Inrush.....	60
3.5 Substation Sizing.....	61
3.6 Breaker Sizing.....	62
3.7 Custom UPS and Power Factor.....	62
3.8 Automatic Bypass Switch.....	63
3.9 Surge Protection.....	63
3.10 Grounded Conductor.....	64
3.11 Redundant Safety Grounds.....	64
3.12 Emergency Shutdown.....	64
3.13 Trays and Conduits.....	64
3.14 Existing TDC 3000 ^X AC Power.....	65
SECTION 4 – PROCESS WIRING.....	67
4.1 Overview.....	67
4.2 FTA Selection.....	68
4.3 Cabinet Entry.....	75
4.4 Signal Tray Wiring Compatibility.....	76
4.5 Process Wiring Termination.....	77
SECTION 5 – HAZARDOUS ENVIRONMENT PLANNING.....	79
5.1 Overview.....	79
5.2 Hazardous Area Classifications.....	80
5.3 PM and APM Hazardous Area Requirements.....	82
5.4 Division 2 (Zone 2) Wiring.....	83
5.5 Process Control Wiring Current Limiting.....	101
SECTION 6 – CORROSION PROTECTION PLANNING.....	103
6.1 Overview.....	103
6.2 Model Numbers.....	106

Table of Contents

SECTION 7 – CE COMPLIANCE	117
7.1 Overview.....	117
7.2 Card Files.....	118
7.3 APMM Cards.....	119
7.4 IOPs.....	119
7.5 FTAs.....	122
7.6 I/O Link Extender.....	130
7.7 IOP to FTA Cables.....	131
7.8 Power Cables.....	132
7.9 I/O Link Interface Cables.....	133
7.10 UCN Trunk Cable Taps.....	134
7.11 Cabinets.....	136
SECTION 8 – MODEL MU-CBSM01/MU-CBDM01 CABINETS	137
8.1 Overview.....	137
8.2 Cabinet Description.....	140
8.3 Card File and Power System Configurations.....	144
8.4 Card File and Power System Description.....	146
8.5 FTA Mounting Channel Description.....	148
8.5.1 Vertical FTA Mounting Channels.....	149
8.5.2 Horizontal FTA Mounting Channel.....	153
8.6 Cabinet Floor Planning.....	157
SECTION 9 – MODEL MU-CBSX01/MU-CBDX01 CABINETS	159
9.1 Overview.....	159
9.2 Cabinet Description.....	163
9.3 Card File and Power System Configurations.....	167
9.4 Card File and Power System Description.....	169
9.5 FTA Mounting Channel Descriptions.....	171
9.5.1 Vertical FTA Mounting Channels.....	172
9.5.2 Horizontal FTA Mounting Channel.....	176
9.6 Cabinet Floor Planning.....	180
SECTION 10 – REDUNDANCY PLANNING	181
10.1 Overview.....	181
10.2 Redundant PMM/APMM Configurations.....	181
10.3 Redundant IOP Placement.....	185
10.4 Redundancy Support.....	187
10.4.1 Power System.....	187
10.4.2 PMM/APMM and I/O Combinations.....	187

Table of Contents

SECTION 11 – I/O LINK EXTENDER PLANNING.....	189
11.1	Overview..... 189
11.2	Description..... 190
11.3	Fiber Optic Cable Routing..... 196
11.3.1	Direct Burial..... 196
11.3.2	Aerial Lashing..... 196
11.3.3	Vertical Installations..... 197
11.3.4	Indoor Requirements..... 197
11.3.5	Loose Buffered Cable..... 197
11.3.6	Number of Fibers..... 198
11.3.7	Cable Installation..... 198
11.4	Indoor Cable Bend Radius..... 199
11.5	Cable Construction..... 199
11.6	Cable Splices and Connections..... 200
11.7	Loss Budget..... 202
11.7.1	Standard I/O Link Extender..... 202
11.7.2	Long Distance I/O Link Extender..... 204
11.8	Power Level Measurement..... 206
SECTION 12 – LOW LEVEL MULTIPLEXER PLANNING.....	207
12.1	Overview..... 207
12.2	LLMux Configurations..... 207
12.3	LLMux IOP Placement..... 210
12.4	Power Adapter Placement..... 210
12.5	LLMux FTA Placement..... 210
12.6	Remote CJR Installation..... 213
SECTION 13 – SERIAL DEVICE INTERFACE PLANNING.....	215
13.1	Overview..... 215
13.2	Serial Device Interface Configurations..... 215
13.3	Serial Device Interface IOP Placement..... 217
13.4	Power Adapter Placement..... 217
13.5	IOP to Power Adapter Cabling..... 217
13.6	Serial Device Interface FTA Placement..... 218
13.7	FTA to Power Adapter Cabling..... 218
13.8	FTA Field Cabling..... 220
13.9	Serial Device Interface FTA Models..... 221
SECTION 14 – SERIAL INTERFACE PLANNING.....	223
14.1	Overview..... 223
14.2	Serial Interface Configurations..... 223
14.3	Serial Interface IOP Placement..... 229
14.4	Power Adapter Placement..... 229
14.5	IOP to Power Adapter Cabling..... 229
14.6	Serial Interface FTA Placement..... 230
14.7	FTA to Power Adapter Cabling..... 230
14.8	FTA Field Cabling..... 232
14.9	Serial Interface FTA Models..... 233
14.10	Communications Interface Specifications..... 234

Table of Contents

SECTION 15 – GALVANICALLY ISOLATED FTA PLANNING.....	235
15.1	Overview..... 235
15.2	Description..... 237
15.3	Features..... 244
15.3.1	IOP Redundancy..... 244
15.3.2	Analog and Digital Output Standby Manual Devices..... 244
15.3.3	Auxiliary Inputs/Outputs..... 245
15.3.4	Power Requirements..... 247
15.3.5	Field Wiring Connections..... 248
15.3.6	Ambient Temperature Limits..... 248
15.3.7	FTA Mounting Channels..... 249
15.4	Power Distribution..... 253
15.4.1	Power Distribution Assembly..... 254
15.4.2	Cabling to Power Distribution Assemblies..... 255
15.4.3	Cabling to FTAs..... 255
15.4.4	Power Considerations..... 256
15.5	High Level Analog Input (HLAI) FTAs..... 257
15.5.1	Model MU-GAIH12/MU-GAIH82 FTA..... 257
15.5.1.1	Description..... 257
15.5.1.2	Connectors..... 257
15.5.1.3	Field Wiring Input Signals..... 257
15.5.1.4	Auxiliary Connector Output..... 258
15.5.1.5	Indicators..... 258
15.5.1.6	Current Consumption..... 258
15.5.1.7	Isolation and Safety..... 258
15.5.2	Model MU-GAIH13/MU-GAIH83 FTA..... 259
15.5.2.1	Description..... 259
15.5.2.2	Connectors..... 259
15.5.2.3	Field Wiring Input Signals..... 260
15.5.2.4	Auxiliary Connector Output..... 260
15.5.2.5	Indicators..... 260
15.5.2.6	Hand-Held Communicator..... 261
15.5.2.7	Current Consumption..... 261
15.5.2.8	Isolation and Safety..... 261
15.5.3	Model MU-GAIH14/MU-GAIH84 FTA..... 262
15.5.3.1	Description..... 262
15.5.3.2	Connectors..... 262
15.5.3.3	Field Wiring Input Signals..... 263
15.5.3.4	Auxiliary Connector Output..... 263
15.5.3.5	Indicators..... 263
15.5.3.6	Hand-Held Communicator..... 264
15.5.3.7	Current Consumption..... 264
15.5.3.8	Isolation and Safety..... 264
15.5.4	Model MU-GAIH22/MU-GAIH92 FTA..... 265
15.5.4.1	Description..... 265
15.5.4.2	Connectors..... 265
15.5.4.3	Field Wiring Input Signals..... 266
15.5.4.4	Auxiliary Connector Output..... 266
15.5.4.5	Indicators..... 266
15.5.4.6	Current Consumption..... 267
15.5.4.7	Isolation and Safety..... 267

Table of Contents

15.6	24 Vdc Digital Input FTAs.....	268
15.6.1	Model MU-GDID12/MU-GDID82 FTA.....	268
15.6.1.1	Description.....	268
15.6.1.2	Connectors.....	268
15.6.1.3	Field Wiring Input Signals.....	269
15.6.1.4	Line-Fault Detection.....	269
15.6.1.5	Auxiliary Connector Output.....	269
15.6.1.6	Indicators.....	270
15.6.1.7	Current Consumption.....	270
15.6.1.8	Isolation and Safety.....	270
15.6.2	Model MU-GDID13/MU-GDID83 FTA.....	271
15.6.2.1	Description.....	271
15.6.2.2	Connectors.....	271
15.6.2.3	Field Wiring Input Signals.....	271
15.6.2.4	Indicators.....	272
15.6.2.5	Current Consumption.....	272
15.6.2.6	Isolation and Safety.....	272
15.7	Analog Output FTAs.....	273
15.7.1	Model MU-GAOX02/72 and MU-GAOX12/82 FTAs.....	273
15.7.1.1	Description.....	273
15.7.1.2	Connectors.....	273
15.7.1.3	Field Wiring Output Signals.....	273
15.7.1.4	Line-Fault Detection.....	274
15.7.1.5	Calibration.....	274
15.7.1.6	Indicators.....	274
15.7.1.7	Current Consumption.....	274
15.7.1.8	Isolation and Safety.....	275
15.8	24 Vdc Digital Output FTAs.....	276
15.8.1	Model MU-GDOD12/MU-GDOD82 FTA.....	276
15.8.1.1	Description.....	276
15.8.1.2	Signal Connectors.....	276
15.8.1.3	Field Wiring Output Signals.....	276
15.8.1.4	Auxiliary Connector.....	277
15.8.1.5	Indicators.....	277
15.8.1.6	Standby Manual Device Connector.....	277
15.8.1.7	Current Consumption.....	278
15.8.1.8	Isolation and Safety.....	278
15.8.2	Model MU-GDOL12/MU-GDOL82 FTA.....	279
15.8.2.1	Description.....	279
15.8.2.2	Signal Connectors.....	279
15.8.2.3	Field Wiring Output Signals.....	279
15.8.2.4	Auxiliary Connector.....	280
15.8.2.5	Indicators.....	280
15.8.2.6	Standby Manual Device Connector.....	281
15.8.2.7	Current Consumption.....	281
15.8.2.8	Isolation and Safety.....	281
15.9	Combiner Panel.....	282
15.10	Marshalling Panel.....	283
15.10.1	Description.....	283
15.10.2	Configurations.....	284
15.10.2.1	High Level Analog Input FTAs.....	284
15.10.2.2	Digital Input FTAs.....	285
15.10.2.3	Digital Output FTAs.....	286

Figures

Figure 2-1	Redundant PMM or APMM Cabinet Layout.....	4
Figure 2-2	Single PMM Card File	6
Figure 2-3	Single APMM Card File.....	7
Figure 2-4	Redundant PMM Card File.....	9
Figure 2-5	Redundant APMM Card File.....	10
Figure 2-6	Input/Output Processor (IOP) Card File.....	12
Figure 2-7	HAI FTA with Redundant HAI IOPs	14
Figure 2-8	Analog Output FTA with Redundant Analog Output IOPs.....	15
Figure 2-9	Standard I/O Link Extender Interconnections with Nonredundant PMM or APMM.....	17
Figure 2-10	Standard I/O Link Extender Interconnections with Redundant PMMs or APMMs	18
Figure 2-11	Long Distance I/O Link Extender Interconnections with Nonredundant PMM or APMM.....	19
Figure 2-12	Long Distance I/O Link Extender Interconnections with Redundant PMMs or APMMs	20
Figure 2-13	Field Termination Assembly (FTA) Sizes.....	24
Figure 2-14	Typical Vertical FTA Mounting Channel Layout.....	26
Figure 2-15	Typical FTA Compression Terminal Connector.....	27
Figure 2-16	Typical FTA Fixed-Screw Terminal Connector	28
Figure 2-17	Typical FTA Removable-Screw Terminal Connector.....	28
Figure 2-18	Crimp Pin-Type Galvanic Isolation Module Terminal Connector.....	29
Figure 2-19	Compression-Type Galvanic Isolation Module	30
Figure 2-20	FTA Marshalling Panel Assembly Layout.....	31
Figure 2-21	Standard Power System – Model MU-PSRX03.....	33
Figure 2-22	Standard Power System – Model MU-PSRX04.....	34
Figure 2-23	AC Only Power System – Not for CE Compliant Applications.....	36
Figure 2-24	Single Cabinet with Redundant PMMs or APMMs.....	38
Figure 2-25	Dual Cabinet with Redundant PMMs or APMMs.....	39
Figure 2-26	Dual Cabinet with Redundant PMMs or APMMs with Remote I/O Cabinet.....	40
Figure 3-1	Subsystem AC Power and Ground Connections – Multi-Ground System.....	45
Figure 3-2	Subsystem AC Power and Ground Connections – Single-Ground System.....	46
Figure 3-3	Crest Factor	58
Figure 4-1	Field Termination Assembly (FTA) Sizes.....	69
Figure 4-2	Field Termination Assembly (FTA) Mounting Dimensions.....	70
Figure 6-1	Conformal Coating Symbol	105
Figure 7-1	I/O Link Extender Adapter Kit.....	130
Figure 7-2	Two-Port UCN Cable Tap.....	134
Figure 7-3	Four-Port UCN Cable Tap	135
Figure 7-4	Eight-Port UCN Cable Tap	135
Figure 8-1	Single Access Cabinet	138
Figure 8-2	Dual Access Cabinet	139
Figure 8-3	Single Access Cabinet Bottom Cable Entry Slots	140
Figure 8-4	Dual Access Cabinet Bottom Cable Entry Slots	141
Figure 8-5	Cabinet Interior Dimensions.....	143
Figure 8-6	Typical Single Access Cabinet Assembly Layout.....	144
Figure 8-7	Typical Dual Access Cabinet Assembly Layout.....	145
Figure 8-8	Card File Installation Dimensions	146
Figure 8-9	Power System Installation Dimensions.....	147
Figure 8-10	Typical Vertical FTA Mounting Channel Configurations.....	150
Figure 8-11	Vertical FTA Mounting Channel Dimensions	151
Figure 8-12	Vertical FTA Mounting Channel Installation Holes	152
Figure 8-13	Horizontal FTA Mounting Channel Cabinet Layout	154
Figure 8-14	Horizontal FTA Mounting Channel Dimensions	155
Figure 8-15	Horizontal FTA Mounting Channel Installation Holes.....	156

Figures

Figure 8-16	Cabinet Floor Planning Template	157
Figure 9-1	Single Access Cabinet	160
Figure 9-2	Dual Access Cabinet	161
Figure 9-3	Cabinet Base Panel Grounding Procedure	162
Figure 9-4	Cabinet Panel and Door Grounding Procedure	162
Figure 9-5	Single Access Cabinet Bottom Cable Entry.....	163
Figure 9-6	Dual Access Cabinet Bottom Cable Entry.....	164
Figure 9-7	Cabinet Interior Dimensions	166
Figure 9-8	Typical Single Access Cabinet Assembly Layout.....	167
Figure 9-9	Typical Dual Access Cabinet Assembly Layout.....	168
Figure 9-10	Card File Installation Dimensions	169
Figure 9-11	Power System Installation Dimensions.....	170
Figure 9-12	FTA Mounting Channel Configurations.....	173
Figure 9-13	FTA Mounting Channel Dimensions.....	174
Figure 9-14	FTA Mounting Channel Mounting FTA Installation Holes.....	175
Figure 9-15	Horizontal FTA Mounting Channel Cabinet Layout	177
Figure 9-16	Horizontal FTA Mounting Channel Dimensions	178
Figure 9-17	Horizontal FTA Mounting Channel Installation Holes	179
Figure 9-18	Cabinet Floor Planning Template	180
Figure 10-1	Single Cabinet with Redundant PMMs or APMMs.....	182
Figure 10-2	Dual Cabinet with Redundant PMMs or APMMs.....	183
Figure 10-3	Redundant PMM or APMM Configuration Cabling	184
Figure 10-4	Local/Remote Cabinet Configuration.....	188
Figure 11-1	Standard I/O Link Extender Interconnections with Nonredundant PMM or APMM.....	191
Figure 11-2	Standard I/O Link Extender Interconnections with Redundant PMMs or APMMs	192
Figure 11-3	Long Distance I/O Link Extender Interconnections with Nonredundant PMM or APMM.....	193
Figure 11-4	Long Distance I/O Link Extender Interconnections with Redundant PMMs or APMMs	194
Figure 11-5	Remote Site Multi-IOP Card File I/O Link Interface Cabling.....	195
Figure 11-6	ST-Type Connector	201
Figure 12-1	LLMux Configuration Interconnections – CE Compliant	209
Figure 12-2	Remote CJR Installation.....	213
Figure 13-1	Serial Device Interface Interconnections.....	216
Figure 14-1	Model MU-TSIM12 Serial Interface FTA Interconnections – Non-CE Compliant	225
Figure 14-2	Model MU-TSIM12 Serial Interface FTA Interconnections – CE Compliant.....	226
Figure 14-3	Model MU-TSIA12 Serial Interface FTA Interconnections – Non-CE Compliant	227
Figure 14-4	Model MU-TSIA12 Serial Interface FTA Interconnections – CE Compliant.....	228
Figure 15-1	Typical Galvanically Isolated FTA.....	239
Figure 15-2	Galvanic Isolation Module.....	240
Figure 15-3	Crimp-Type Galvanic Isolation Module Terminal Connector.....	241
Figure 15-4	Compression-Type Galvanic Isolation Module Terminal Connector	242
Figure 15-5	Galvanically Isolated FTA with Auxiliary Connector	246
Figure 15-6	Cabinet with Horizontally Installed FTA Mounting Channels.....	250

Tables

Table 2-1	Standard Field Termination Assembly Types.....	22
Table 2-2	Galvanically Isolated Field Termination Assembly Types.....	23
Table 3-1	PM and APM Assembly 24 Vdc Power Usage	49
Table 3-2	Single Power System Calculation Example	53
Table 3-3	Dual Power System Calculation Example (Power System 1)	54
Table 3-4	Dual Power System Calculation Example (Power System 2)	55
Table 4-1	Standard FTAs and Associated Assemblies.....	71
Table 4-2	Galvanically Isolated FTAs and Associated Assemblies	74
Table 5-1	Hazardous Area Classifications.....	80
Table 5-2	PM and APM Equipment Approved for Use in Division 2 Areas.....	84
Table 5-3	FTA Cable and Load Parameters.....	100
Table 6-1	Harsh Environment Definitions from ANSI/ISA-S71.04-1985	104
Table 6-2	Conformal Coated Assembly Model Numbers	107
Table 7-1	Card Files	118
Table 7-2	IOPs – Nonconformally Coated	120
Table 7-3	IOPs – Conformally Coated.....	121
Table 7-4	Field Termination Assemblies – Nonconformally Coated.....	122
Table 7-5	Field Termination Assemblies – Conformally Coated.....	126
Table 7-6	IOP to FTA Cables.....	131
Table 7-7	Power Cables	132
Table 7-8	I/O Link Interface Cables.....	133
Table 11-1	Minimum Bend Radius for Indoor Cable	199
Table 11-2	Standard Optical Power Loss.....	203
Table 11-3	Standard Fiber Optic Cable Losses (@ 850 nm)	203
Table 11-4	Long Distance Optical Power Loss.....	205
Table 11-5	Long distance Fiber Optic Cable Losses (@ 1300 nm).....	205
Table 12-1	Low Level Analog Input Multiplexer FTAs	207
Table 14-1	Serial Interface FTAs	223
Table 14-2	Serial Interface EIA-232 Specifications	234
Table 14-3	Serial Interface EIA-422/485 Specifications	234
Table 15-1	CE Compliant Galvanically Isolated FTAs.....	238
Table 15-2	Galvanically Isolated FTA Power Requirements	247

Acronyms

AC	Alternating Current
AO	Analog Output
APMM	Process Manager Module
APM	Advanced Process Manager
CJR	Cold Junction Reference
DI	Digital Input
DO	Digital Output
EMI	Electromagnetic Interference
FTA	Field Termination Assembly
GI	Galvanic Isolation
HLAI	High Level Analog Input
I/O	Input/Output
IEC	International Electrotechnical Commission
LCN	Local Control Network
LLAI	Low Level Analog Input
LLMux	Low Level Analog Input Multiplexer
MRG	Master Reference Ground
NEC	National Electrical Code
NFPA	National Fire Protection Agency
NiCad	Nickel Cadmium
NIM	Network Interface Module
PI	Pulse Input
PM	Process Manager
PMM	Process Manager Module
PSM	Power Supply Module (model MU-PSRX02)
PS	Power System
RTD	Resistive Temperature Device
RTU	Remote Terminal Unit
SDI	Serial Device Interface
SI	Serial Interface
STI	Smart Transmitter Interface
TC	Thermocouple
UCN	Universal Control Network
UCN	Universal Control Network
UV	Ultra Violet

References

Publication Title	Publication Number	Binder Title	Binder Number
<i>Process Manager Specification and Technical Data</i>	PM03-500	System Summary - 2	TDC 3010-2
<i>Advanced Process Manager Specification and Technical Data</i>	AP03-500	System Summary - 2	TDC 3010-2
<i>Process Manager I/O Specification and Technical Data</i>	IO03-500	System Summary - 2	TDC 3010-2
<i>Galvanic Isolation/Intrinsic Safety FTA Specification and Technical Data</i>	GA03-500	System Summary - 2	TDC 3010-2
<i>Universal Control Network Specification and Technical Data</i>	UN03-500	System Summary - 2	TDC 3010-2
<i>Process Manager/Advanced Process Manager Installation</i>	PM20-501	Implementation/PM/APM	TDC 3043
<i>Process Manager/Advanced Process Manager Checkout</i>	PM20-511	Implementation/PM/APM	TDC 3043
<i>Process Manager/Advanced Process Manager Service</i>	PM13-501	PM/APM/HPM Service - 1	TDC 3061-1
<i>Universal Control Network Planning</i>	UN02-501	System Site Planning - 1	TDC 3020-1
<i>Local Control Network Planning</i>	SW02-501	System Site Planning - 1	TDC 3020-1
<i>TDC 3000^X System Site Planning</i>	SW02-550	System Site Planning - 1	TDC 3020-1
<i>Universal Control Network Installation</i>	UN20-500	Installation/Universal Control Network	TDC 3041
<i>Universal Control Network Guidelines</i>	UN12-510	Installation/Universal Control Network	TDC 3041
<i>LCN System Installation</i>	SW20-500	LCN Installation	TDC 3025
<i>LCN System Checkout</i>	SW20-510	LCN Installation	TDC 3025
<i>LCN Guidelines - Implementation, Troubleshooting, and Service</i>	LC09-510	LCN Installation	TDC 3025

Section 1 – Introduction

1.1 Overview

Section contents The topics covered in this section are:

	Topic	See Page
1.1	Overview.....	1

The manual's purpose This manual is intended for planning the installation of a Process Manager (PM) or Advanced Process Manager (APM) subsystem at a TDC 3000^X site. The Process Manager and Advanced Process Manager subsystems are devices on the Universal Control Network (UCN) that includes the Network Interface Module (NIM). The Logic Managers (LM) can also be resident on the network.

The manual's contents Planning includes the consideration of the Process Manager or Advanced Process Manager cabinet layout, process wiring techniques, Division 2 environment equipment approval, conformal coating of the assemblies to protect against a corrosive environment, PMM or APMM and IOP redundancy, and unique hardware features, such as fiber optic I/O Link Extenders, Low Level Analog Input Multiplexer FTAs, Serial Device Interface FTAs, Serial Interface FTAs, and Galvanically Isolated FTAs.

Information not covered Neither installation, power on checkout, or service of the Process Manager or Advanced Process Manager, nor planning for the Local Control Network (LCN) is addressed in this manual. See the related reference documentation for information about these topics.

Section 2 – PM/APM Description

2.1 Overview

Section contents

The topics covered in this section are:

	Topic	See Page
2.1	Overview.....	3
2.2	Card Files.....	5
2.2.1	PMM/APMM Card Files.....	5
2.2.2	Input/Output Processor (IOP) Card File	12
2.3	Input/Output Processors (IOPs).....	13
2.3.1	IOP Redundancy.....	14
2.4	I/O Link Extender (Fiber Optic Link).....	16
2.5	Field Termination Assemblies (FTAs)	21
2.6	Power Systems	32
2.7	Cabinet Configurations	37

PM or APM major assemblies

The Process Manager (PM) or Advanced Process Manager subsystem (APM) consists of major assemblies described in the following subsections. The major Process Manager or Advanced Process Manager assemblies are

- Process Manager Module (PMM)/Advanced Process Manager Module (APMM) card file
- Input/Output Processor (IOP) card file
- Input/Output Processor (IOP) card
- I/O Link Extender
- Field Termination Assembly (FTA)
- Power System

Continued on next page

2.1 Overview, Continued

Redundant PMM or APMM cabinet layout

Figure 2-1 is an illustration of a single Process Manager or Advanced Process Manager cabinet containing a redundant Process Manager Module (PMMs) or Advanced Process Manager Modules (APMMs) with supporting assemblies.

Figure 2-1 Redundant PMM or APMM Cabinet Layout

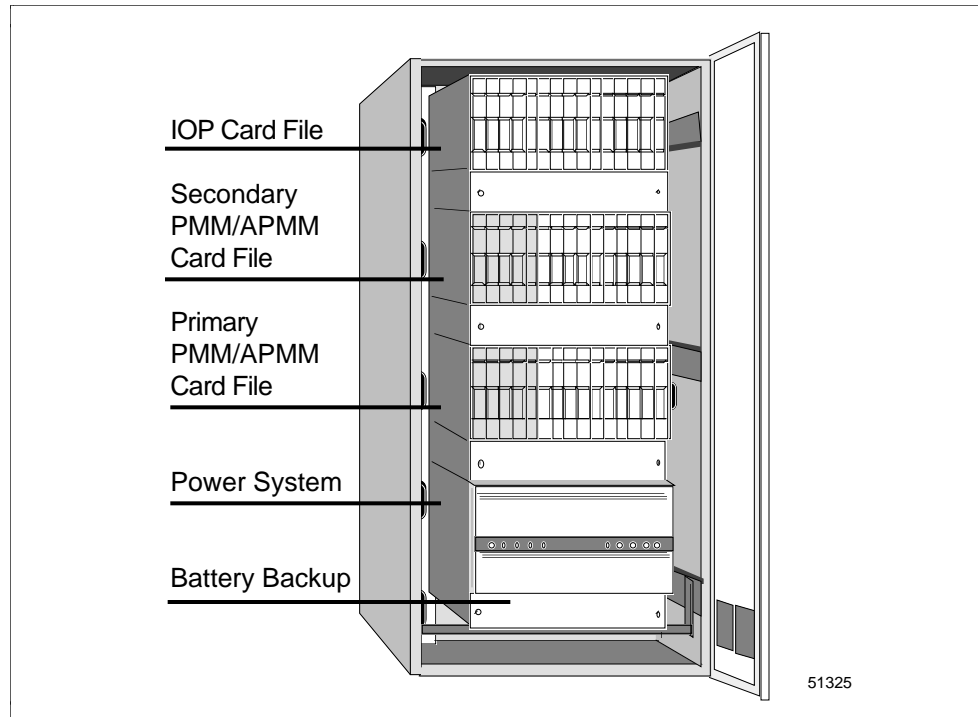

2.2 Card Files

2.2.1 PMM/APMM Card Files

PMM or APMM description

The Process Manager Module (PMM) or Advanced Process Manager Module (APMM) is composed of five card assemblies in a PMM/APMM card file, one of which can provide the interface to an optional redundant PMM or APMM in a second PMM/APMM card file.

Two types of PMM/APMM card files

There are two types of PMM/APMM card files.

Single PMM/APMM card file

The single PMM/APMM card file contains a single PMM or APMM as illustrated in Figures 2-2 and 2-3, respectively. Two single PMM/APMM card files create a redundant Process Manager or Advanced Process Manager.

Continued on next page

2.2.1 PMM/APMM Card Files, Continued

Single PMM Card File

Figure 2-2 illustrates a single PMM card file and the five cards that comprise the PMM.

Figure 2-2 Single PMM Card File

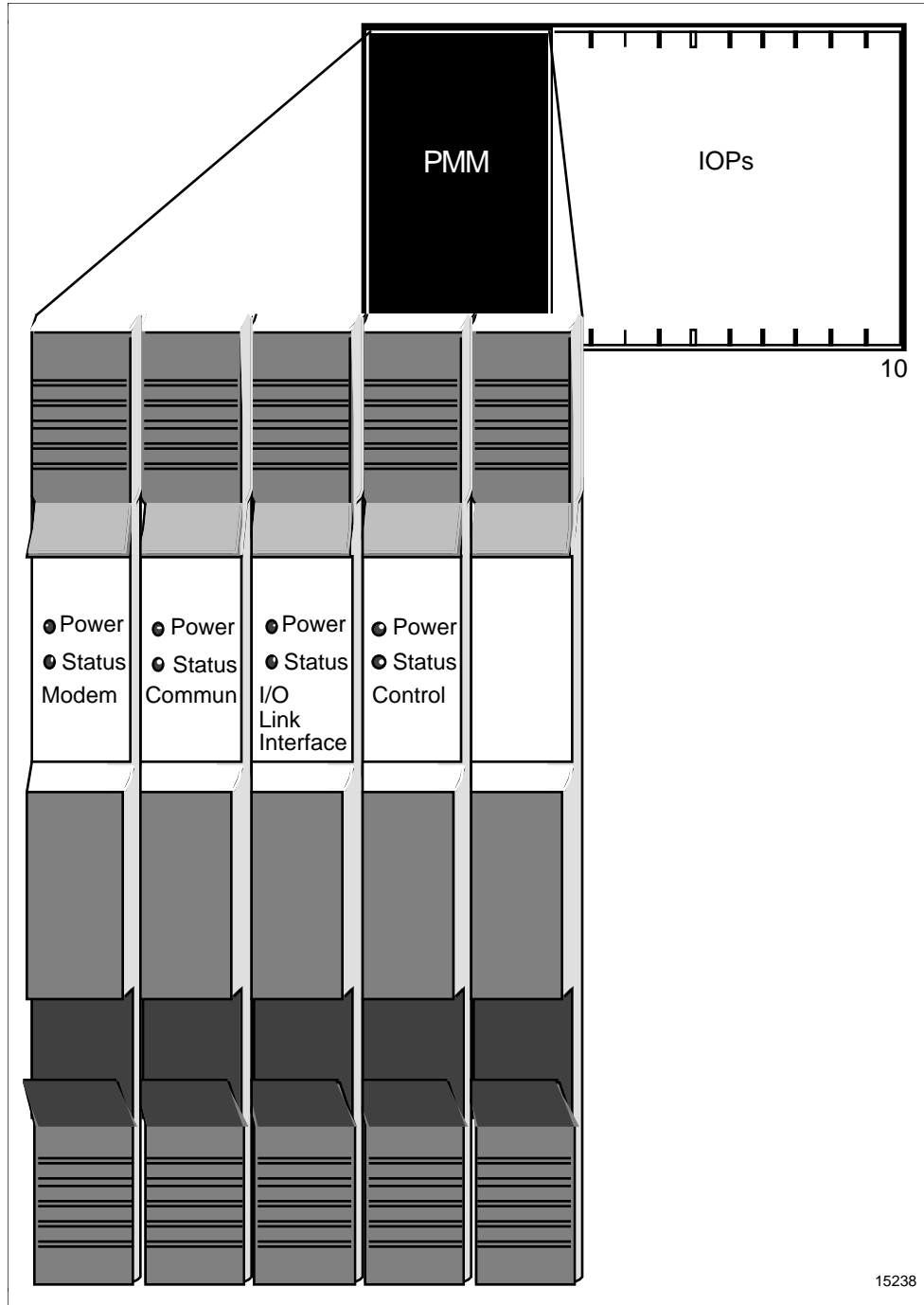

Continued on next page

2.2.1 PMM/APMM Card Files, Continued

Single APMM card file

Figure 2-3 illustrates a single APMM card file and the five cards that comprise the APMM.

Figure 2-3 Single APMM Card File

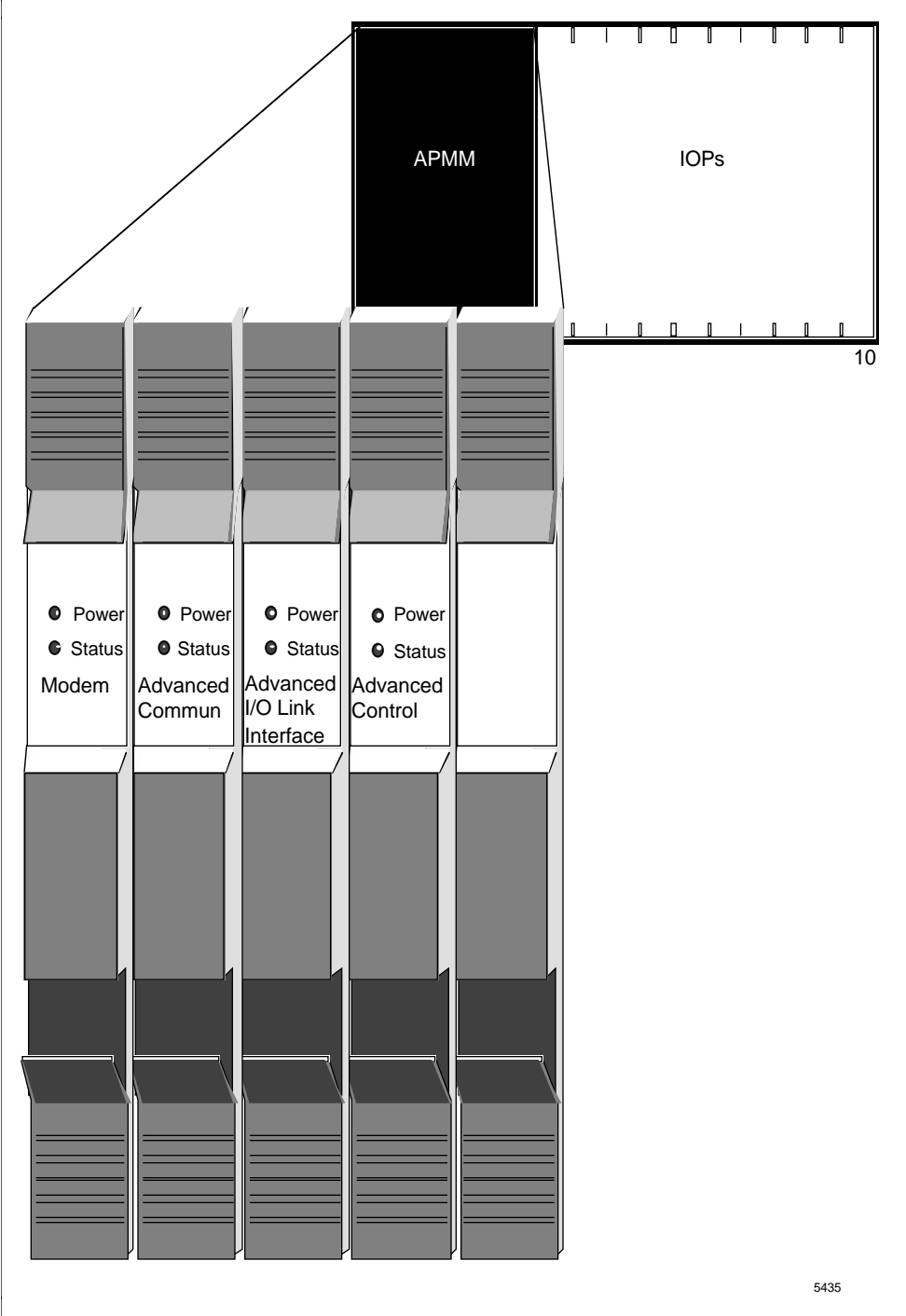

5435

Continued on next page

2.2.1 PMM/APMM Card Files, Continued

Redundant PMM/APMM card file

Another type of card file, the redundant PMM/APMM card file, can also create a redundant Process Manager or Advanced Process Manager; however, both PMMs or APMMs reside in the same card file as illustrated in Figures 2-4 and 2-5, respectively.

Continued on next page

2.2.1 PMM/APMM Card Files, Continued

Redundant PMM card file

Figure 2-4 illustrates a redundant PMM card file and the two sets of five cards that comprise the redundant PMMs.

Figure 2-4 Redundant PMM Card File

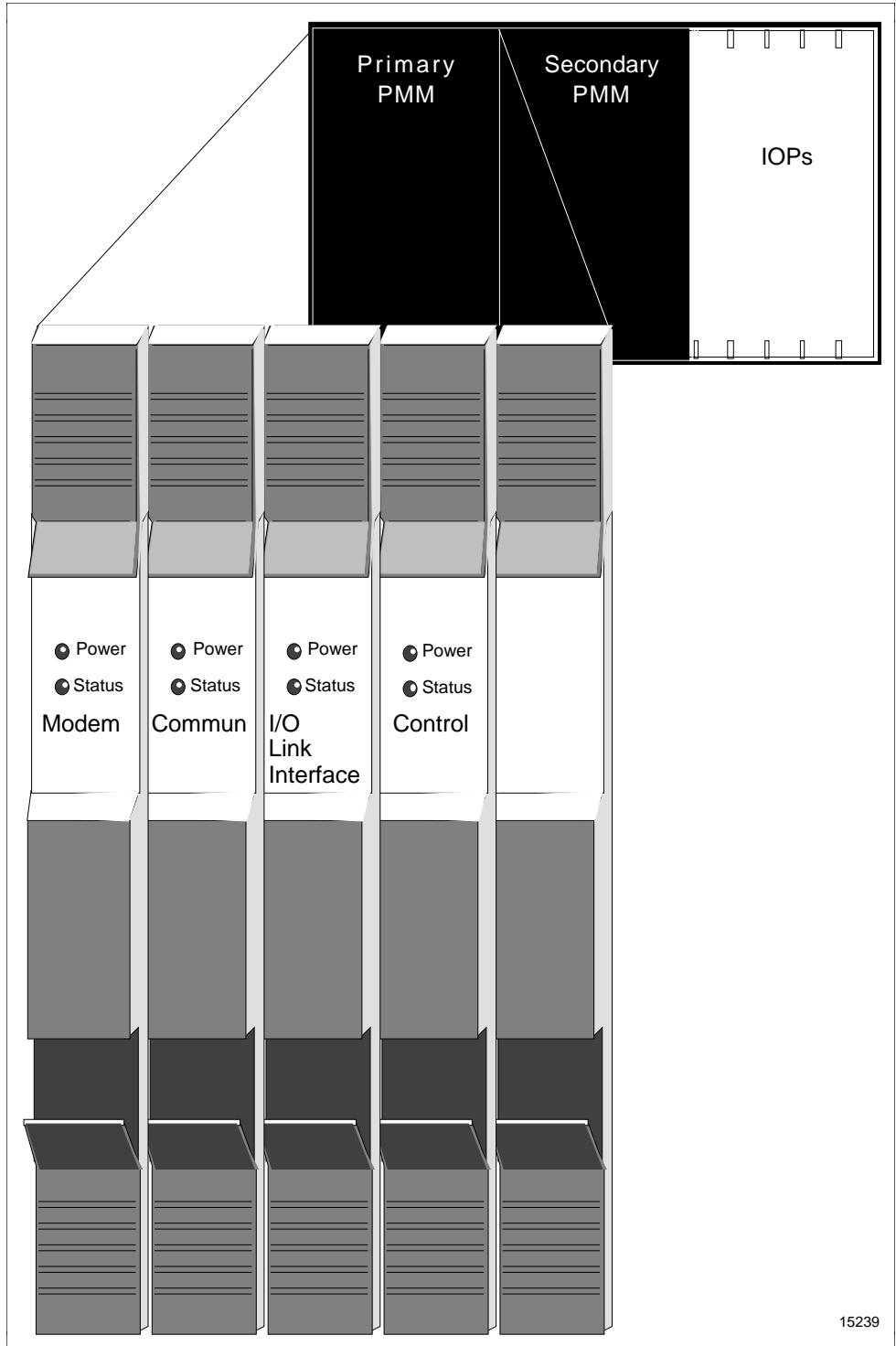

15239

2.2.1 PMM/APMM Card Files, Continued

Redundant APMM card file

Figure 2-5 illustrates a redundant APMM card file and the two sets of five cards that comprise the redundant APMMs.

Figure 2-5 Redundant APMM Card File

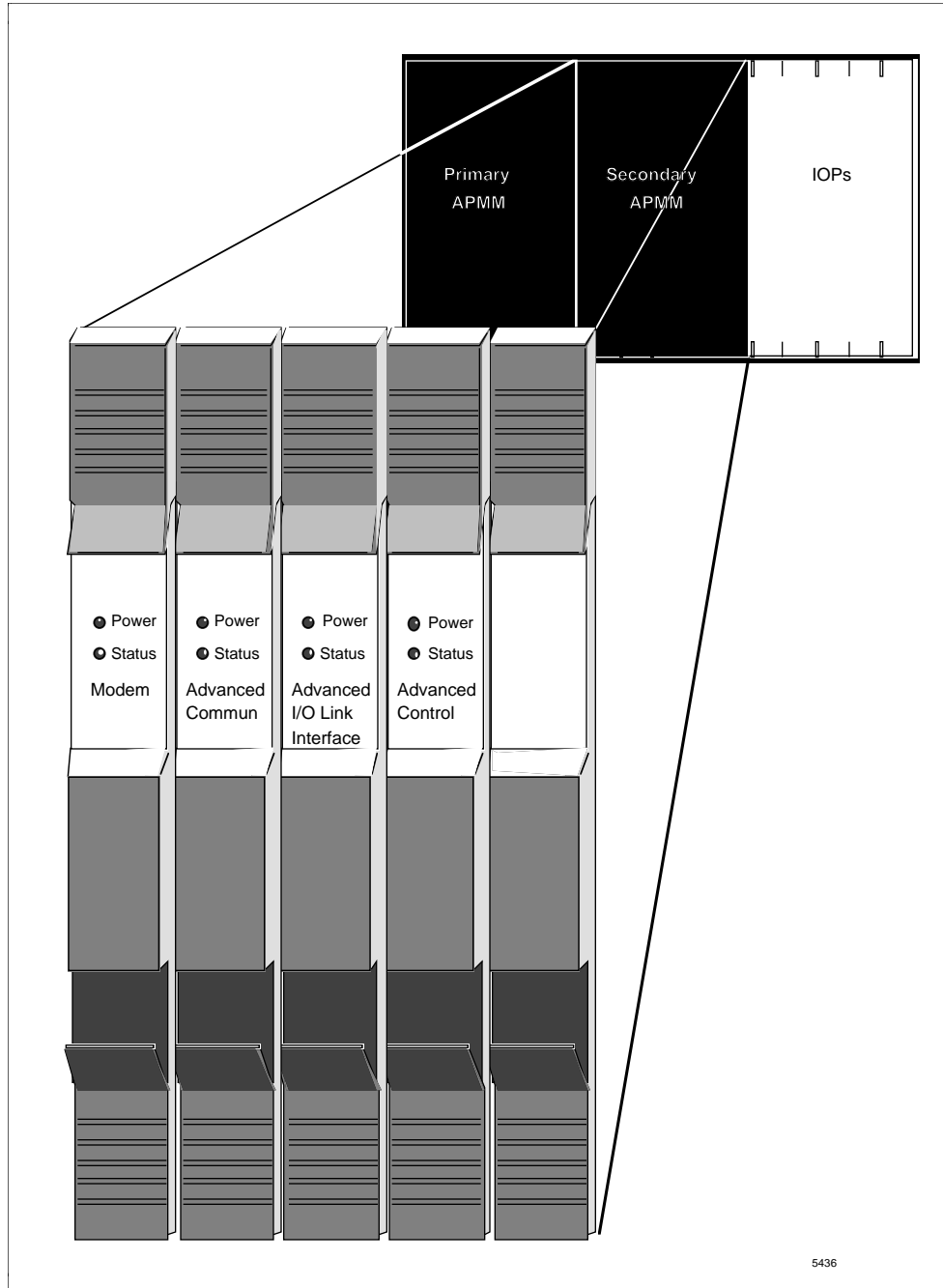

Continued on next page

2.2.1 PMM/APMM Card Files, Continued

PMM/APMM card file descriptions

In a single PMM/APMM card file, the PMM or APMM occupies the first five card slots (from the left). The remaining 10 card slots can be populated with up to 10 Input/Output Processor (IOP) and I/O Link Extender cards.

In a redundant PMM/APMM card file, the two PMMs or APMMs occupy the first ten card slots (from the left). The remaining five card slots can be populated with up to five Input/Output Processor (IOP) and I/O Link Extender cards.

The IOPs interface both the PMM or APMM through the I/O Link Interface and the Field Termination Assemblies (FTAs) by cable.

PMM or APMM functionality

The PMM or APMM provides the following functions.

- Communication with the Local Control Network (LCN) through the Universal Control Network (UCN)
 - Communication with the IOPs through the I/O Link Interface
 - Control processor
 - Memory for the control processor's database
 - Redundancy control
-

2.2.2 Input/Output Processor (IOP) Card File

IOP card file

Figure 2-6 illustrates a 15-slot Input/Output Processor (IOP) card file. The IOP card file accommodates only IOPs.

Figure 2-6 Input/Output Processor (IOP) Card File

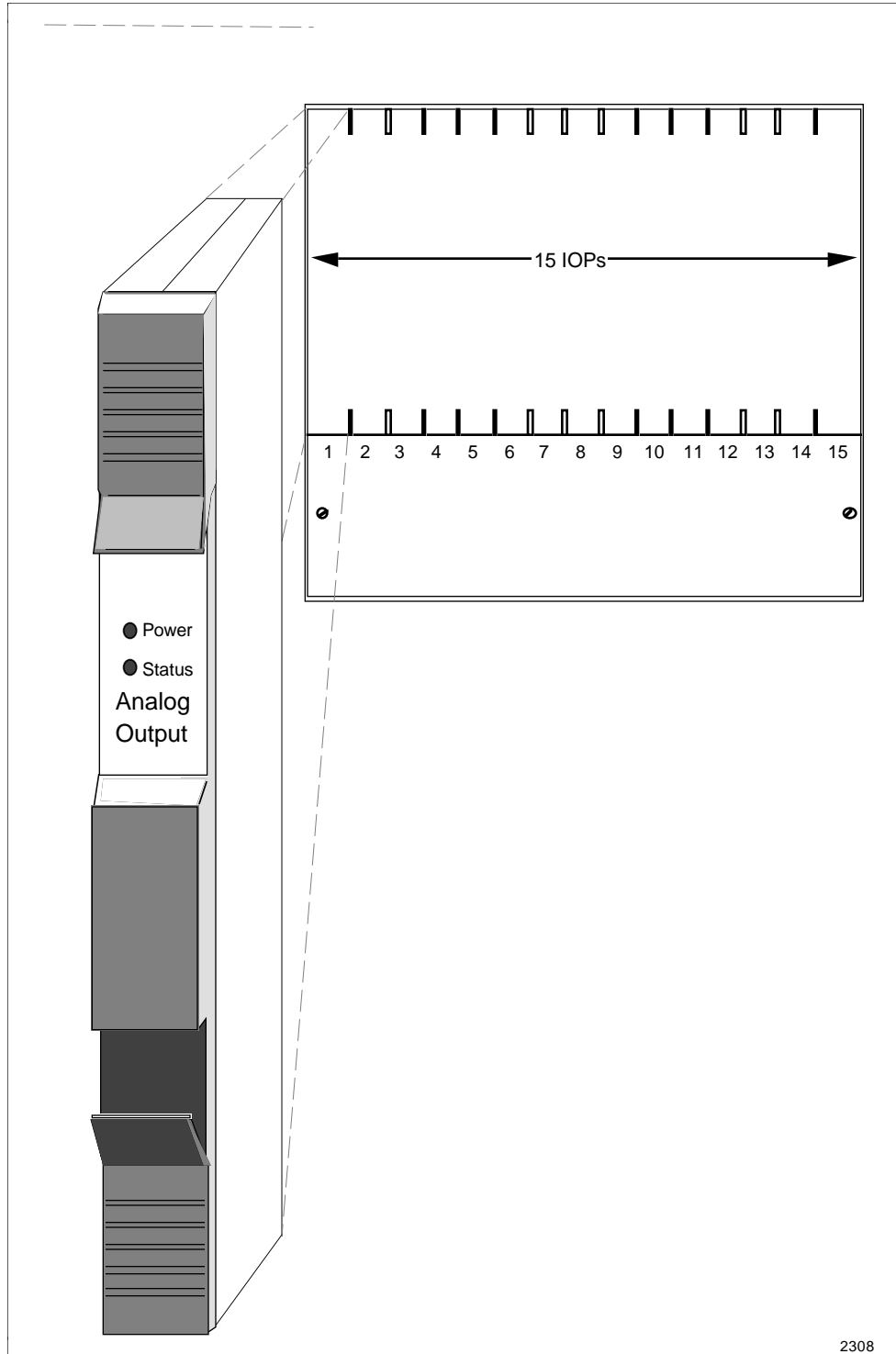

2.3 Input/Output Processors (IOPs)

Types of Input/Output Processors (IOPs)

There are eleven types of Input/Output Processor (IOP) card assemblies. Some IOP card types interface with more than one type of Field Termination Assembly (FTA); however, some IOPs models are dedicated to particular FTA models. The functional types of IOPs are

- High Level Analog Input (HLAI)
- Low Level Analog Input (LLAI)
- Low Level Analog Multiplexer (LLMux)
- Digital Input (DI)
- Analog Output (AO)
- Digital Output (DO)
- Smart Transmitter Interface (STI or STIM)
- Pulse Input (PI)
- Digital Input Sequence of Events (DISOE)
- Serial Device Interface (SDI)
- Serial Interface (SI)

IOP configurations

Additional IOP card file slots can be added to any Process Manager or Advanced Process Manager subsystem. Each IOP card file accommodates up to 15 IOPs as shown in Figure 2-6. A total of eight card files, including PMM/APMM card files, can exist in a Process Manager or Advanced Process Manager subsystem. IOP card files can be installed at remote locations with the use of I/O Link Extenders, as well as locally in the cabinet or cabinet complex containing the PMM(s) or APMM(s).

A total of 40 primary IOPs, 40 secondary (redundant) IOPs and 3 I/O Link Extenders (a maximum of 8 I/O Link Extender cards) can exist in a single Process Manager or Advanced Process Manager subsystem.

2.3.1 IOP Redundancy

IOP redundancy

The PM and APM subsystems support IOP redundancy for the following types of IOPs.

- High Level Analog Input (HLAI)
- Smart Transmitter Interface (STI)
- Analog Output (AO)
- Digital Input (DI)
- Digital Input Sequence of Events (DISOE)
- Digital Output (DO)

Presently, not all Digital Input and Digital Output IOP models support redundancy.

Redundant HLAI IOPs

A pair of IOPs can be connected in a redundant configuration with both IOPs connected by separate cables to the same FTA. Figure 2-7 illustrates an HLAI FTA that interfaces with a pair of HLAI IOPs that are installed in separate card files.

Figure 2-7 HLAI FTA with Redundant HLAI IOPs

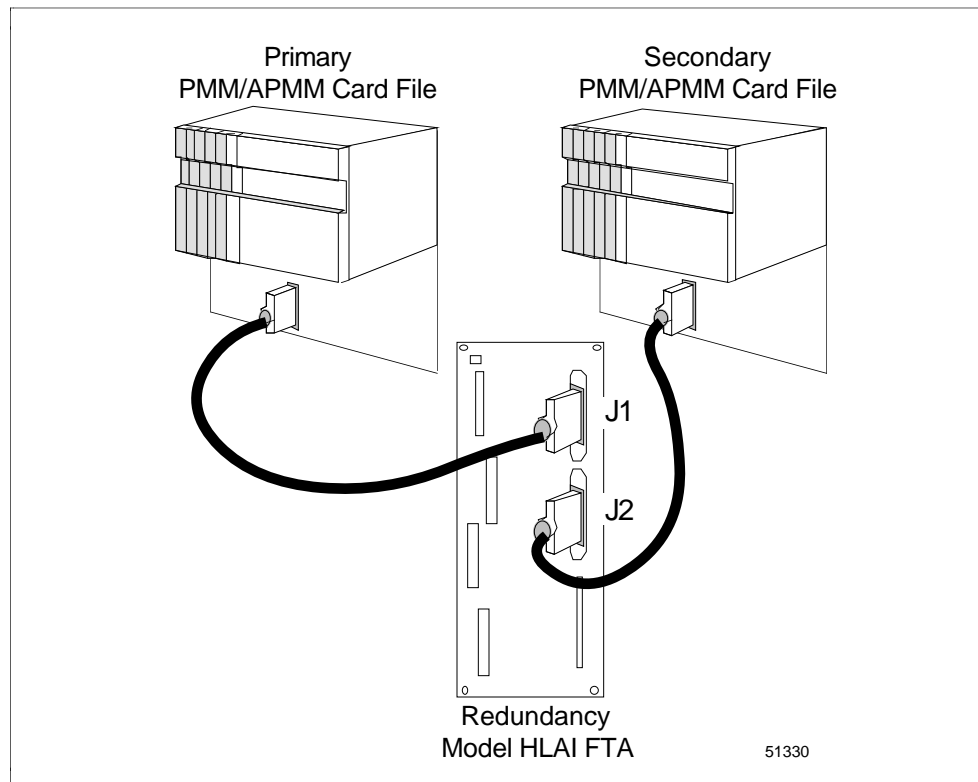

Continued on next page

2.3.1 IOP Redundancy, Continued

Redundant AO IOPs

Analog Output FTAs can also interface with two IOPs with separate cables, and an automatic selector switch on the FTA selects which IOP's output drives the field wiring terminal connectors on the FTA. Figure 2-8 is an illustration of an Analog Output FTA interface with two Analog Output IOPs.

Figure 2-8 Analog Output FTA with Redundant Analog Output IOPs

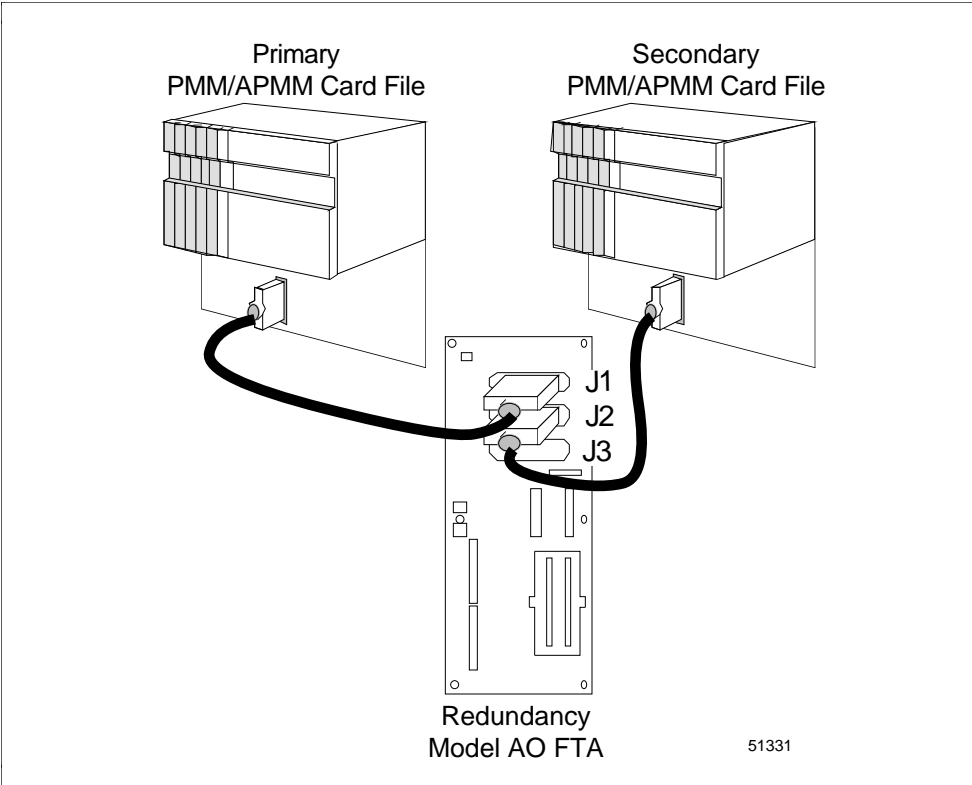

2.4 I/O Link Extender (Fiber Optic Link)

Introduction

The I/O Link Extender provides the ability to locate IOP card files and associated FTAs up to 8 kilometers (5 miles) from the PMM(s) or APMM(s). Two types of I/O Link Extenders and their associated fiber optic couplers are available, the “Standard” I/O Link Extender that provides up to a 1.3 kilometers (4000 feet) link, and the “Long Distance” I/O Link Extender that provides up to an 8 kilometers (5 miles) link. The connection is made by using a pair of fiber optic transmission cables, driven and terminated by a fiber optic coupler that mates with the connector located directly below the card file slot in which the I/O Link Extender card is installed.

Features

An I/O Link Extender consists of two pairs I/O Link Extender cards, one for Link A and one for Link B, and associated fiber optic couplers at each end of the fiber optic link. The I/O Link Extender cards and their fiber optic couplers occupy two slots in an PMM (APMM) or IOP card file.

Remote card files

Every remote card file, or complex of IOP card files, requires two I/O Link Extender cards and two fiber optic couplers, one for Link A and one for Link B.

Fiber optic cable length

The maximum fiber optic cable length is dependent upon the number of splices and quality of the cable (dB loss per meter of cable). This maximum can be between 0.98 and 1.3 kilometers for the Standard I/O Link Extender and 8 kilometers for the Long Distance I/O Link Extender.

I/O Link Extender planning

I/O Link Extender planning can be found in Section 9 in this manual.

Standard I/O Link Extender

Each Standard I/O Link Extender card has an associated fiber optic coupler that can drive up to three pair of fiber optic cables. Each cable pair is terminated by a fiber optic coupler that terminates one fiber optic pair.

The Standard I/O Link Extender card will drive and terminate Link A or Link B, depending upon the card file’s I/O Link Interface address and the slot number’s I/O Link Interface address. If the card file and slot number I/O Link Interface addresses are both odd or both even, the card will drive Link A. If the card file and slot number I/O Link Interface addresses are not both odd or both even, the card will drive Link B.

Two Standard I/O Link Extender cards, connecting up to six remote card files, can be installed in a PMM or APMM card file, but the maximum number of primary IOPs is still 40 (plus 40 redundant IOPs).

Continued on next page

2.4 I/O Link Extender (Fiber Optic Link), Continued

Nonredundant PMM/APMM Standard I/O Link Extender

Figure 2-9 illustrates the interconnections for a Standard I/O Link Extender in a PM or APM that contains a nonredundant PMM or APMM.

Figure 2-9 Standard I/O Link Extender Interconnections with Nonredundant PMM or APMM

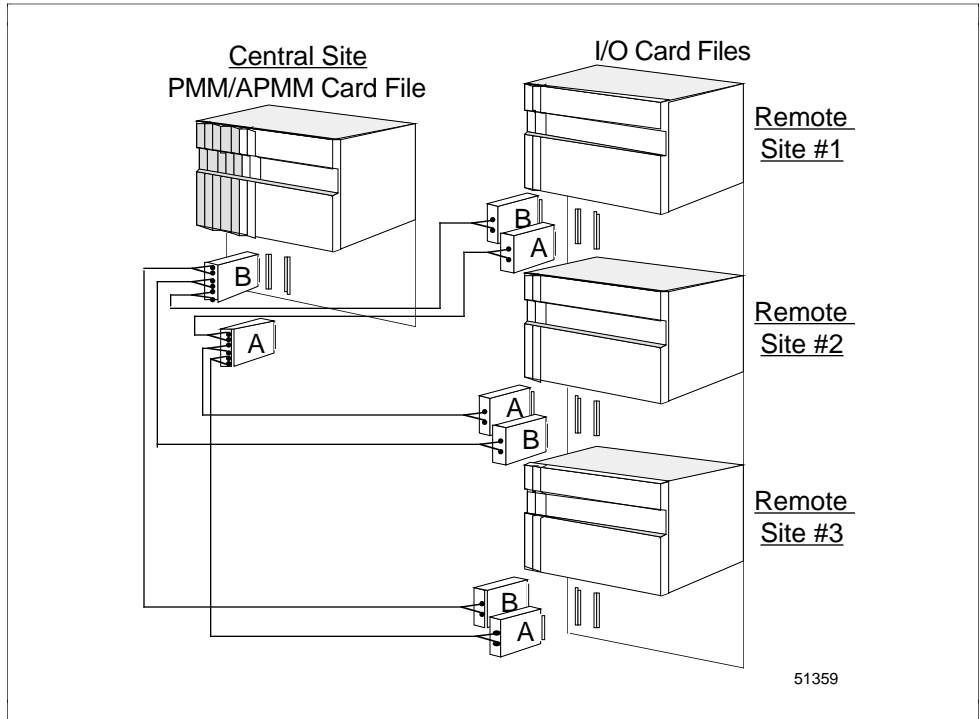

Continued on next page

2.4 I/O Link Extender (Fiber Optic Link), Continued

Redundant PMMs/APMMs Standard I/O Link Extender connections

Figure 2-10 illustrates the interconnections for a Standard I/O Link Extender in a PM or APM that contains redundant PMMs or APMMs.

Figure 2-10 Standard I/O Link Extender Interconnections with Redundant PMMs or APMMs

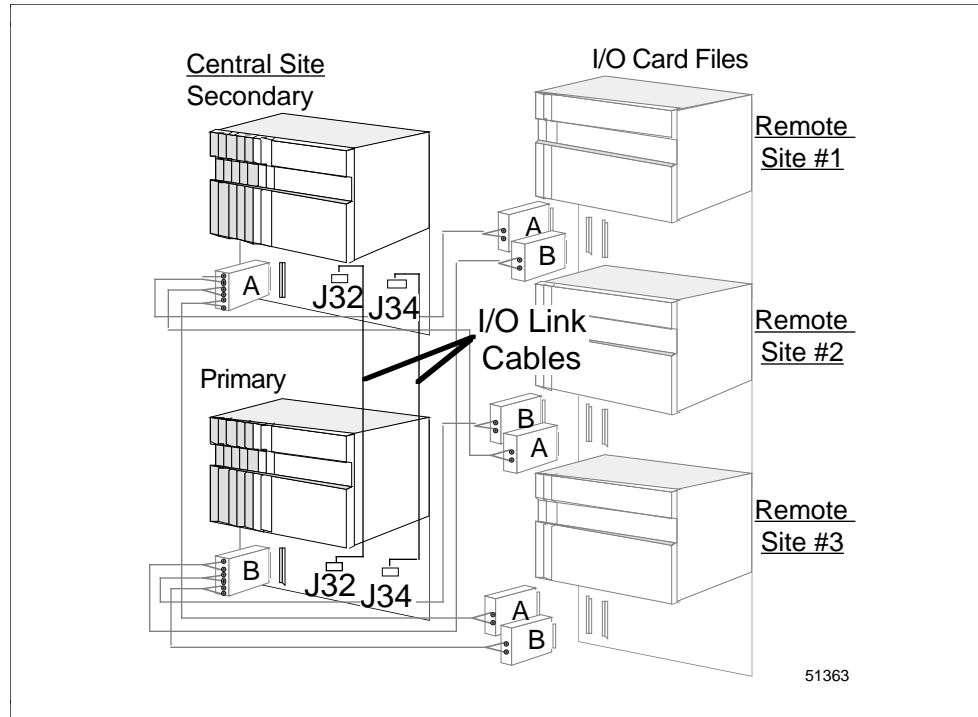

Continued on next page

2.4 I/O Link Extender (Fiber Optic Link), Continued

Long Distance I/O Link Extender

Each Long Distance I/O Link Extender card has an associated fiber optic coupler that drives a single pair of fiber optic cables. Each cable pair is terminated by a fiber optic coupler that terminates one fiber optic pair.

The Link A or Link B selection for the Long Distance I/O Link Extender is determined by a jumper on the card.

Nonredundant PMM/APMM Long Distance I/O Link Extender connections

Figure 2-11 illustrates the interconnections for a Long Distance I/O Link Extender in a PM or APM that has a nonredundant PMM or APMM.

Figure 2-11 Long Distance I/O Link Extender Interconnections with Nonredundant PMM or APMM

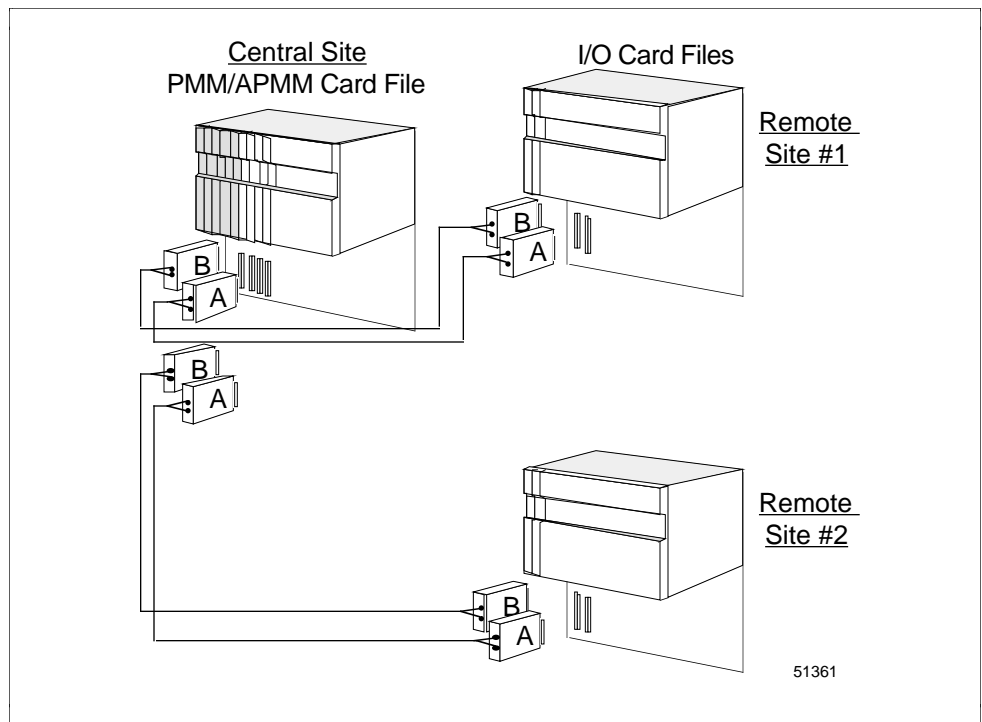

Continued on next page

2.4 I/O Link Extender (Fiber Optic Link), Continued

Redundant PMMs/APMMs Long Distance I/O Link Extender connections

Figure 2-12 illustrates the interconnections for a Long Distance I/O Link Extender in a PM or APM that has redundant PMMs or APMMs.

Figure 2-12 Long Distance I/O Link Extender Interconnections with Redundant PMMs or APMMs

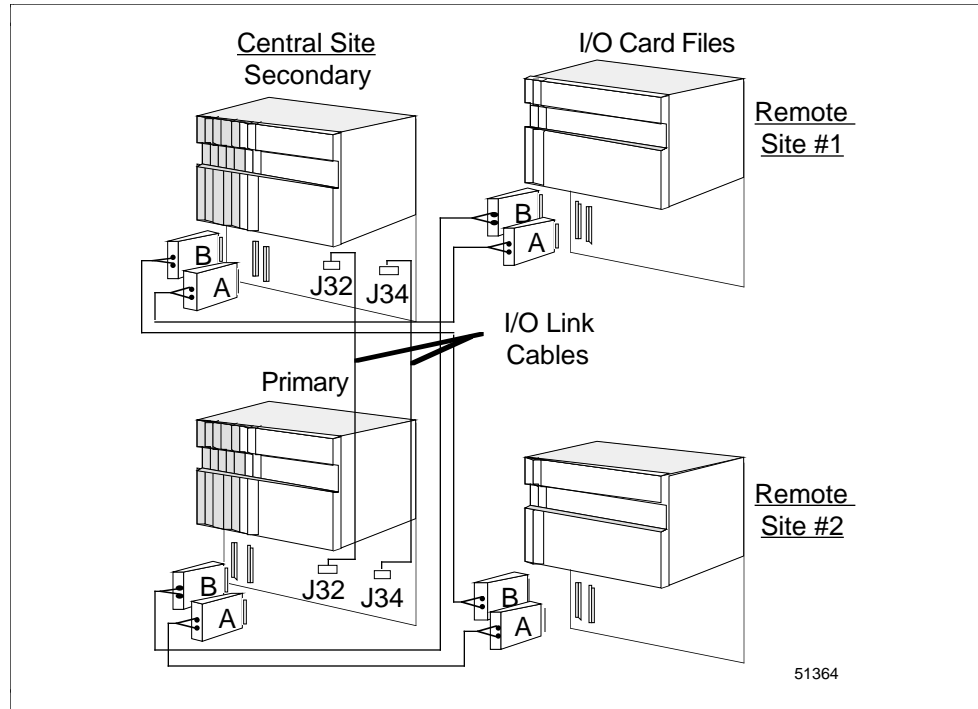

2.5 Field Termination Assemblies (FTAs)

Description	Terminal connectors on the Field Termination Assembly (FTA) provide the connection points for the field wiring. Fuses, relays, and resistors protect the FTA circuitry and sense, condition, or operate the connected device. The FTA communicates with an associated IOP, which in turn communicates with the PMM(s) or APMM(s).
FTAs types	Standard types of FTAs, as described in Table 2-1, interface the field wiring and provide communication with an associated IOP. They are categorized as “standard” because Galvanically Isolated FTAs are also available as described in Table 2-2.

Continued on next page

2.5 Field Termination Assemblies (FTAs), Continued

Standard FTA types Standard FTA types are listed in Table 2-1.

Table 2-1 Standard Field Termination Assembly Types

FTA Type	Description
High Level Analog Input/ Smart Transmitter Interface (HLAI/STI)	Accepts high level analog inputs. The inputs are configurable as single-ended or differential in relation to logic ground. The FTA is also used to interface Smart Transmitter devices.
High Level Analog Input (HLAI)	Accepts high level analog inputs. The inputs are configurable as single-ended or differential in relation to logic ground.
Smart Transmitter Interface (STI)	Interfaces with Smart Transmitter devices. The interface is referenced to logic ground. The Smart Transmitter provides field isolation.
Low Level Analog Input (LLAI)	Can be configured to accept low-level or high-level analog inputs. Low-level analog inputs include Thermocouples (TC), Resistance Temperature Detectors (RTDs), or millivolt sources. High-level inputs such as voltage sources (0-5 V) and 4-20 milliamp current loop devices are acceptable. The inputs are isolated from each other and the PM or APM, but share a common bus for field wire shields.
Low Level Analog Input Multiplexer (LLMux)	Accepts one set of low-level analog inputs, such as thermocouples (TC) or Resistance Temperature Detectors (RTDs). The set of inputs must be either TCs or RTDs. The inputs are sequentially multiplexed. One or two FTAs of either type can be connected to one Power Adapter assembly and its IOP.
Analog Output (AO)	Provides 4-20 mA analog outputs to proportioning loads such as valves.
120 Vac Digital Input (DI)	Accepts ac digital inputs. All inputs are isolated from each other. Two versions of the FTA are available, with and without pluggable input modules.
240 Vac Digital Input (DI)	Similar to the 120 Vac DI FTA, except it has a higher operating voltage and a lower sense current. The inputs are in four groups of eight circuits with a common return for each group. Groups are isolated from each other.
24 Vdc Digital Input (DI)	Accepts contacts grouped with an isolated common return. Two versions of the FTA are available, with pluggable and without pluggable input modules.
120/240 Vac Solid-State Digital Output (DO)	Provides solid-state ac digital outputs that are isolated from each other and the PM or APM.
3-30 Vdc Solid-State Digital Output (DO)	Provides dc digital outputs that are isolated from each other and the PM or APM.
31-200 Vdc Solid-State Digital Output (DO)	Provides dc digital outputs that are isolated from each other and the PM or APM.
24 Vdc Nonisolated Digital Output (DO)	Provides nonisolated digital outputs to loads such as lamps and relays. The signals are referenced to logic common.
24 Vdc Isolated Digital Output (DO)	Provides isolated digital outputs to loads such as lamps and relays. The signals are not referenced to logic common.
120 Vac/125 Vdc Relay Digital Output (DO)	Provides independent electromechanical relays for ac or dc digital outputs.

Continued on next page

2.5 Field Termination Assemblies (FTAs), Continued

Standard FTA types, continued

Table 2-1 Standard Field Termination Assembly Types, Continued

FTA Type	Description
240 Vac/125 Vdc Relay Digital Output (DO)	Provides independent electromechanical relays for ac or dc digital outputs.
Pulse Input (PI)	Accepts eight inputs, each with a 32-bit counter, and have a frequency range of dc to 20 kHz. The inputs are referenced to logic ground.
Serial Device interface (SDI Toledo)	The SDI FTA provides an EIA-232 (RS-232) asynchronous serial communications interface for a model 8142-2084 or 8142-2184 Toledo Weigh Cell peripheral manufactured by Toledo Scale Inc.
Serial Device interface (SDI M/A Station)	The SDI FTA provides an EIA-422/485 (RS-422/485) asynchronous serial communications interface for up to four model MU-MASX02 Manual/Auto Station peripherals manufactured by Honeywell Inc.
Serial Device interface (SDI UDC 6000)	The SDI FTA provides an EIA-422/485 (RS-422/485) asynchronous serial communications interface for up to four UDC 6000 Modbus peripherals manufactured by Honeywell Inc.
Serial Interface (SI Modbus RTU)	The SI FTA provides either an EIA-232 (RS-232) asynchronous serial communications interface for one Modbus compatible device or an EIA-422/485 (RS-422/485) asynchronous serial communications interface for up to 15 Modbus RTU compatible devices.
Serial Interface (Allen-Bradley)	The SI FTA accommodates a single EIA-232 compatible Allen-Bradley device through its EIA-232 interface.

Galvanically Isolated FTA types

Galvanically Isolated FTA types are listed in Table 2-2.

Table 2-2 Galvanically Isolated Field Termination Assembly Types

FTA Type	Description
High Level Analog Input (HLAI/STI)	The HLAI/STI FTA accepts high level analog inputs. All inputs are isolated from ground and each other. The FTA is also used to interface Smart Transmitter devices.
High Level Analog Input (HLAI)	The HLAI FTA accepts high level analog inputs. All inputs are isolated from ground and each other.
24 Vdc Digital Input (DI)	The 24 Vdc DI FTA accepts contact inputs. All inputs are isolated from each other.
Analog Output (AO)	The AO FTA provides isolated 4-20 mA outputs to proportioning loads such as valves.
24 Vdc Digital Output (DO)	The 24 Vdc DO FTA provides isolated digital outputs to loads such as solenoid valves or lamps.

Continued on next page

2.5 Field Termination Assemblies (FTAs), Continued

Three physical sizes

The standard FTAs have three physical sizes as illustrated in Figure 2-13. The Galvanically Isolated FTAs are one size only, B-size.

Figure 2-13 Field Termination Assembly (FTA) Sizes

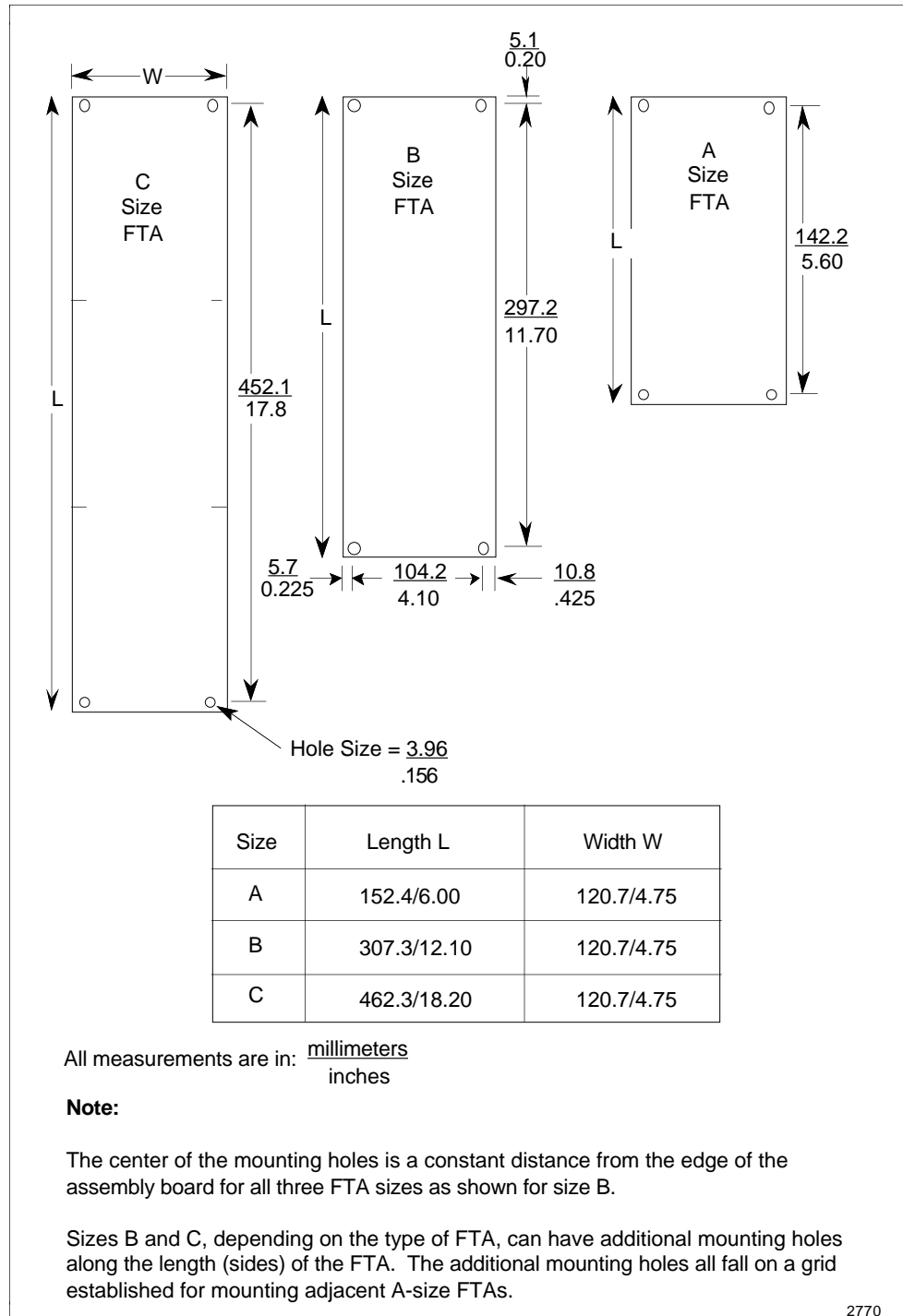

Continued on next page

2.5 Field Termination Assemblies (FTAs), Continued

FTA Mounting Channels

The FTAs are installed at the rear or front of a dual-access cabinet on one or more FTA Mounting Channels. In a single-access cabinet, the FTAs are mounted on FTA Mounting Channels at the front of the cabinet. The FTA Mounting Channels also function as cable and wiring channels, or troughs. The standard and Galvanically Isolated FTAs must not be mounted on the same FTA Mounting Channel. Mounting both types of FTAs on the same FTA Mounting Channel is an Intrinsic Safety violation.

Vertical orientation

All FTAs except Galvanically Isolated FTAs are mounted on vertically oriented 3-foot long FTA Mounting Channel segments.

Horizontal orientation

Galvanically Isolated FTAs are mounted on horizontally oriented 2-foot long FTA Mounting Channels.

Continued on next page

2.5 Field Termination Assemblies (FTAs), Continued

Typical cabinet layout

A typical cabinet layout of FTA Mounting Channels that demonstrates the installation of standard FTAs in a dual-access Process Manager or Advanced Process Manager cabinet is shown in Figure 2-14.

Figure 2-14 Typical Vertical FTA Mounting Channel Layout

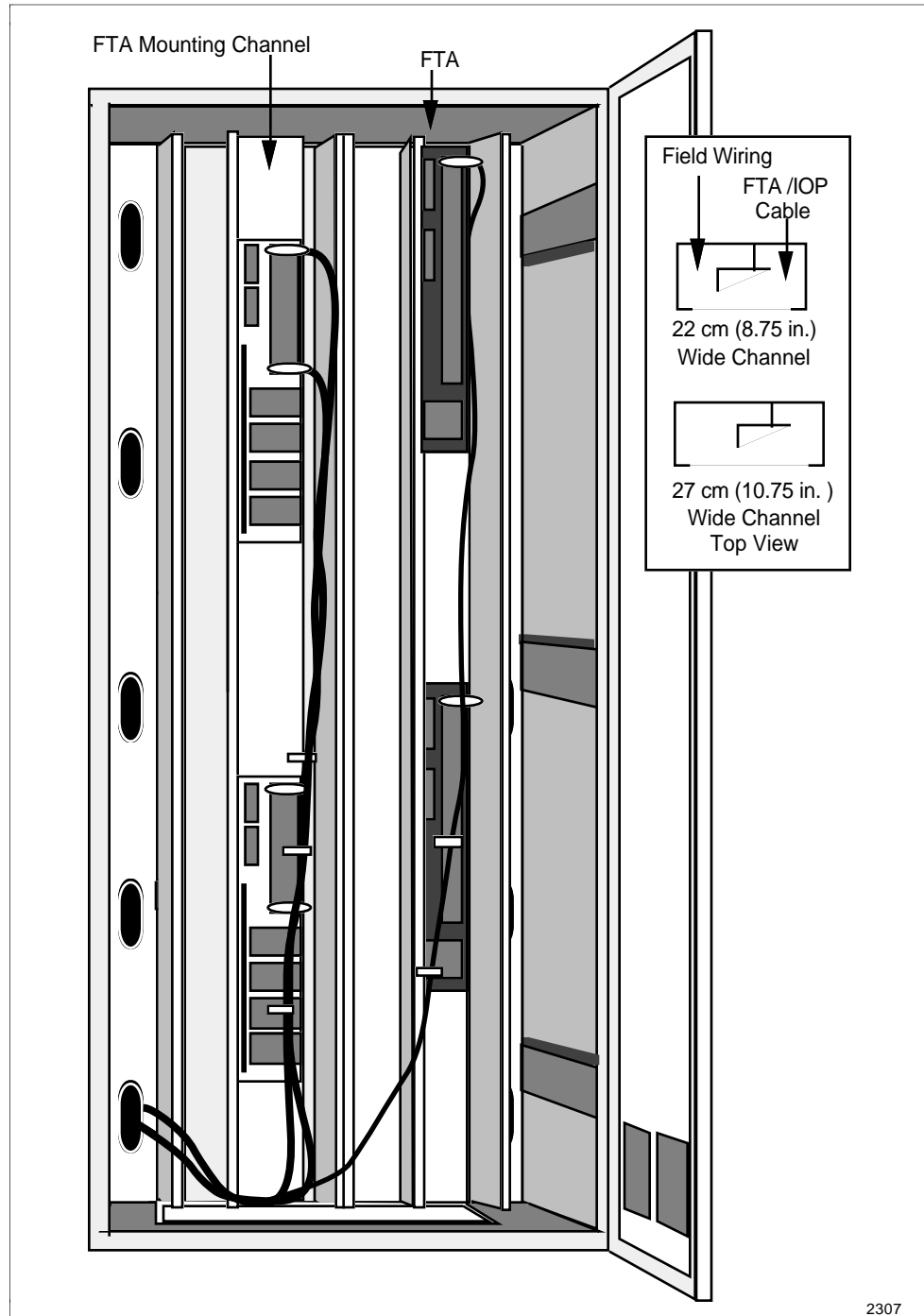

Continued on next page

2.5 Field Termination Assemblies (FTAs), Continued

Compression or screw terminals available

Most standard FTA types are available with either compression-type or screw-type terminal connectors. Some exceptions are the 6-inch Analog Output (AO), 6-inch High Level Analog Input (HLAI), 6-inch Low Level Analog Input Multiplexer (LLMux), and the 6-inch Digital Input Power Distribution Assembly, which are available with compression-type terminal connectors only. The number of terminals for both the compression-type and screw-type terminal connector can vary depending on the type of standard FTA.

All Galvanically Isolated FTAs are available with both crimp pin-type and compression-type terminal connectors. The Marshalling Panel is available only with screw-type terminal connectors.

FTA compression-type terminal connector

Figure 2-15 is an illustration of a typical compression-type terminal connector connection to a standard FTA.

Figure 2-15 Typical FTA Compression Terminal Connector

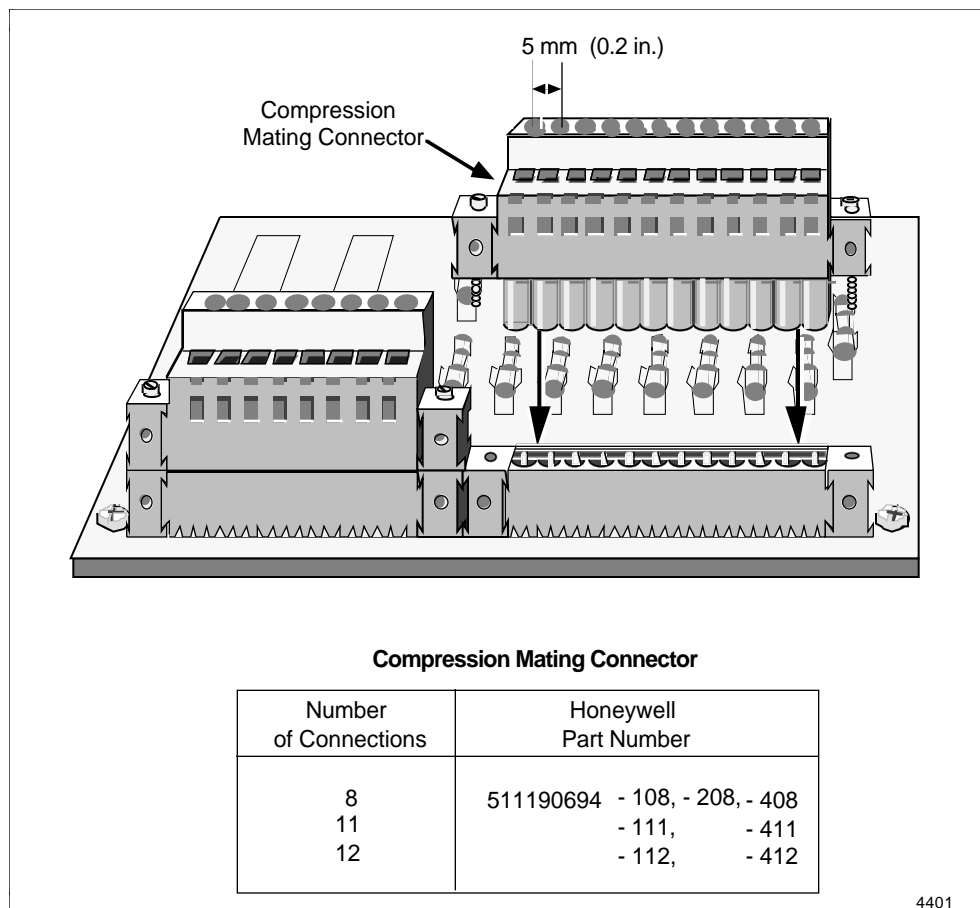

Continued on next page

2.5 Field Termination Assemblies (FTAs), Continued

FTA fixed-screw terminal connector

Figure 2-16 illustrates a typical fixed-screw terminal connector as it would appear on a standard FTA.

Figure 2-16 Typical FTA Fixed-Screw Terminal Connector

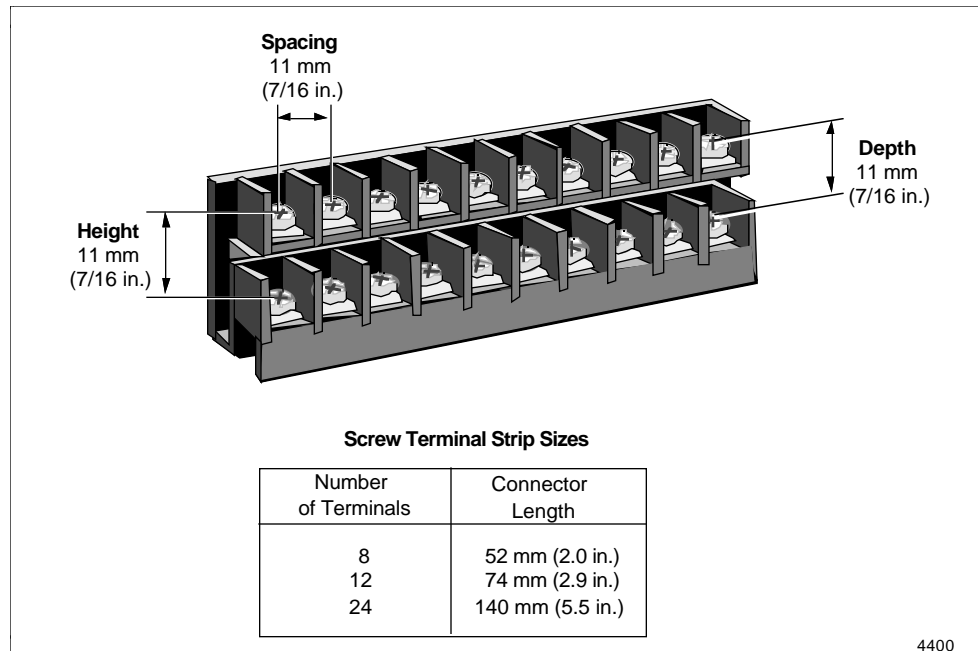

FTA removable-screw terminal connector

Figure 2-17 illustrates a typical removable-screw terminal connector.

Figure 2-17 Typical FTA Removable-Screw Terminal Connector

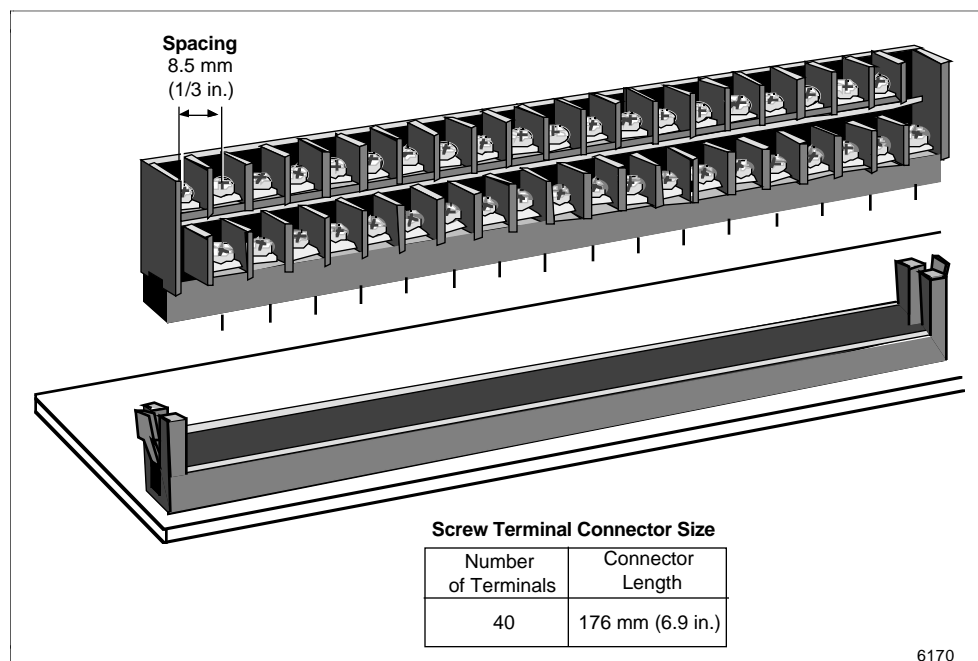

Continued on next page

2.5 Field Termination Assemblies (FTAs), Continued

Galvanic Isolation Module connectors

Figures 18 and 19 illustrate the crimp pin-type and compression-type terminal connectors for the Galvanically Isolated FTAs, respectively. The connectors on the Galvanic Isolation Modules have six terminals. Depending on the type of terminal connector, the terminals accept size 0.3 to 3.5 mm² (12 to 22 AWG) wiring.

Crimp pin-type terminal connector

Figure 2-18 illustrates the crimp pin-type Galvanic Isolation Module terminal connector.

Figure 2-18 Crimp Pin-Type Galvanic Isolation Module Terminal Connector

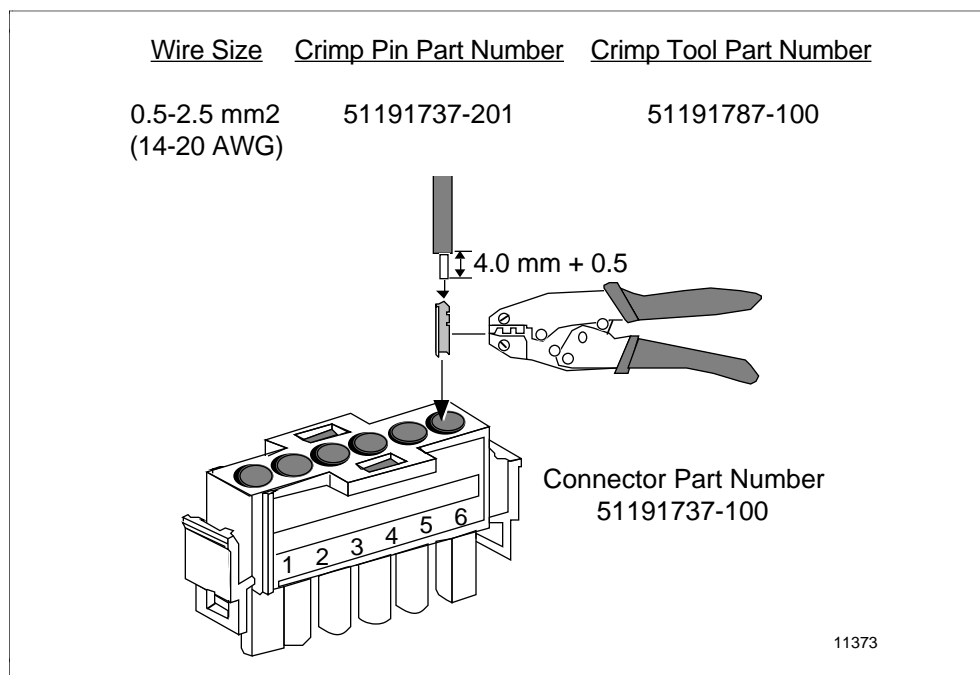

Continued on next page

2.5 Field Termination Assemblies (FTAs), Continued

Compression-type terminal connector

Figure 2-19 illustrates the compression-type Galvanic Isolation Module terminal connector.

Figure 2-19 Compression-Type Galvanic Isolation Module Terminal Connector

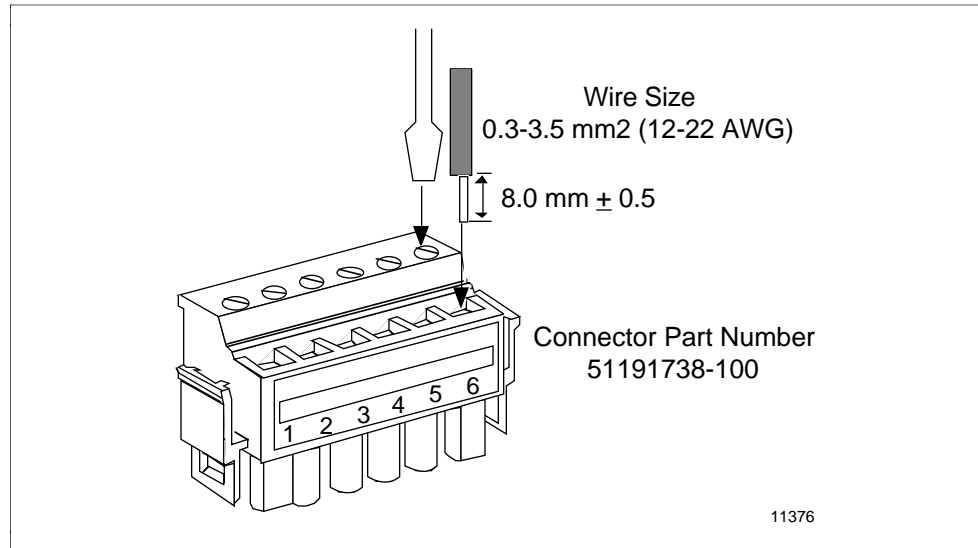

Continued on next page

2.5 Field Termination Assemblies (FTAs), Continued

Marshalling Panel

The Marshalling Panel was developed to provide access to the signals from the auxiliary connectors on the Galvanically Isolated FTAs. It can also be used as a general purpose Marshalling Panel in the Process Manager or Advanced Process Manager subsystem.

Figure 2-20 illustrates an assembly layout of the panel. The Marshalling Panel, model MU-GMAR52, is similar in shape and appearance to a “B” size FTA (see Figure 2-9). The assembly provides surge and ESD protection for the field wiring terminals. A 50-pin connector is provided on the assembly that accepts an IOP to FTA cable.

Figure 2-20 FTA Marshalling Panel Assembly Layout

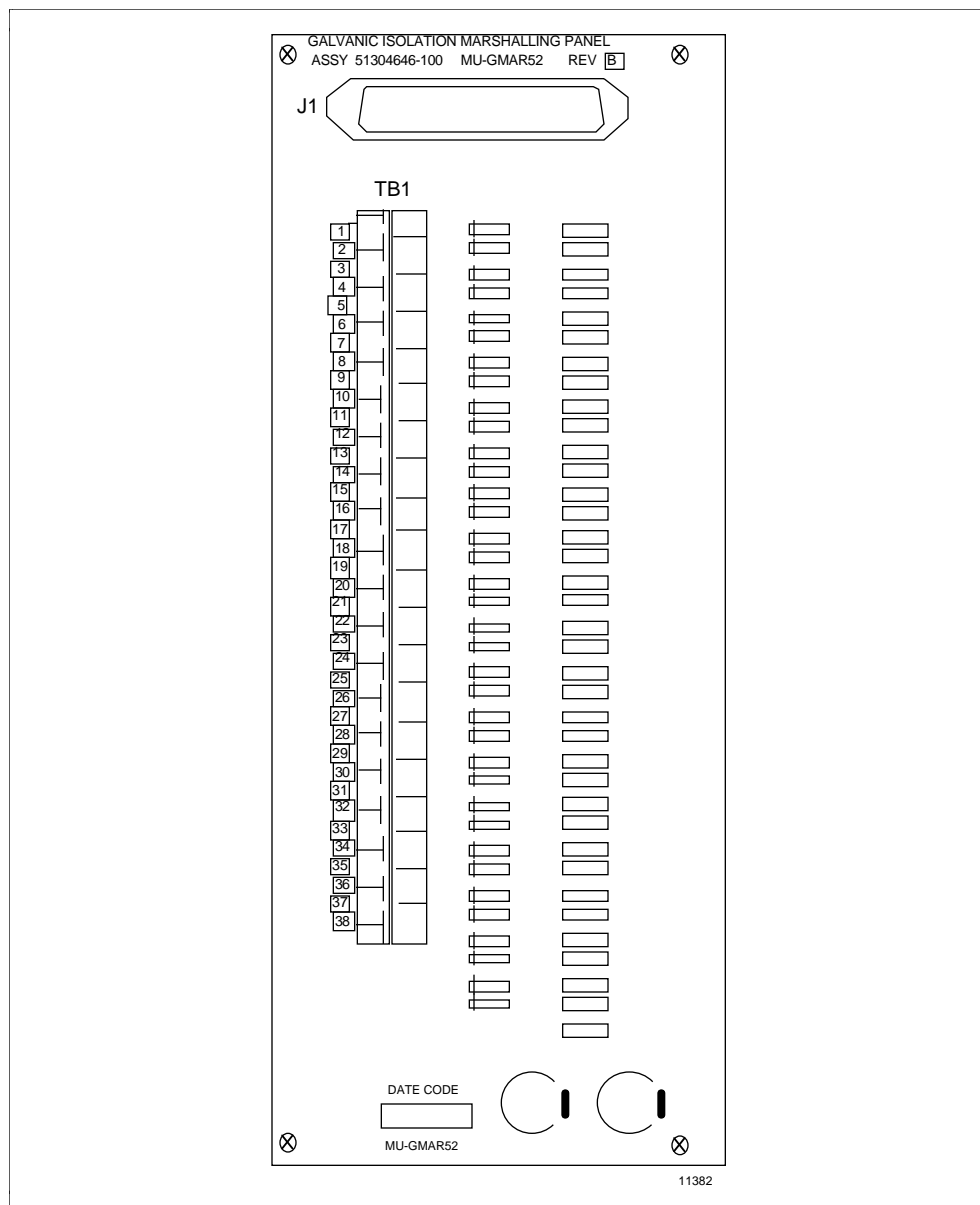

2.6 Power Systems

Power System features The Process Manager or Advanced Process Manager Power System provides 24 Vdc power for operation of all PMM or APMM cards, IOP cards, FTAs, a nominal 3.6 Vdc battery output for backup of the PMM or APMM and IOP memory circuits, and a nominal 1/4 ampere, 6 Vac output for operation of a LLAI line frequency clock circuit. There are two types of Power Systems.

Standard Power System The Standard Power System has many features that include

- An optional redundant Power Supply Module (model MU-PSRX03/04).
- Either 120 Vac or 240 Vac input power. A single- or dual-source of input power can be connected when the optional redundant Power Supply Module option is implemented.
- Single and redundant Power Supply Module failure detection.
- CMOS memory NiCad battery backup (3.6 Vdc) for 12 hours (model MU-PSRX03) or 45 hours (model MU-PSRX04) backup with failure detection.
- An optional 48 Vdc Battery Backup Module (model MU-PSRB02) with a disconnect switch that backs up the 24 Vdc for 25 minutes.

Redundant Power Supply Modules Redundant Power Supply Modules are recommended when the Power System provides power for redundant PMMs or APMMs. If the redundant PMMs or APMMs are resident in separate cabinets with their own Power System, a Power System with a single Power Supply Module is acceptable, though not fully recommended.

Continued on next page

2.6 Power Systems, Continued

Model MU-PSRX03 Standard Power System

The layout of the model MU-PSRX03 Standard Power System is illustrated in Figure 2-21.

Figure 2-21 Standard Power System—Model MU-PSRX03

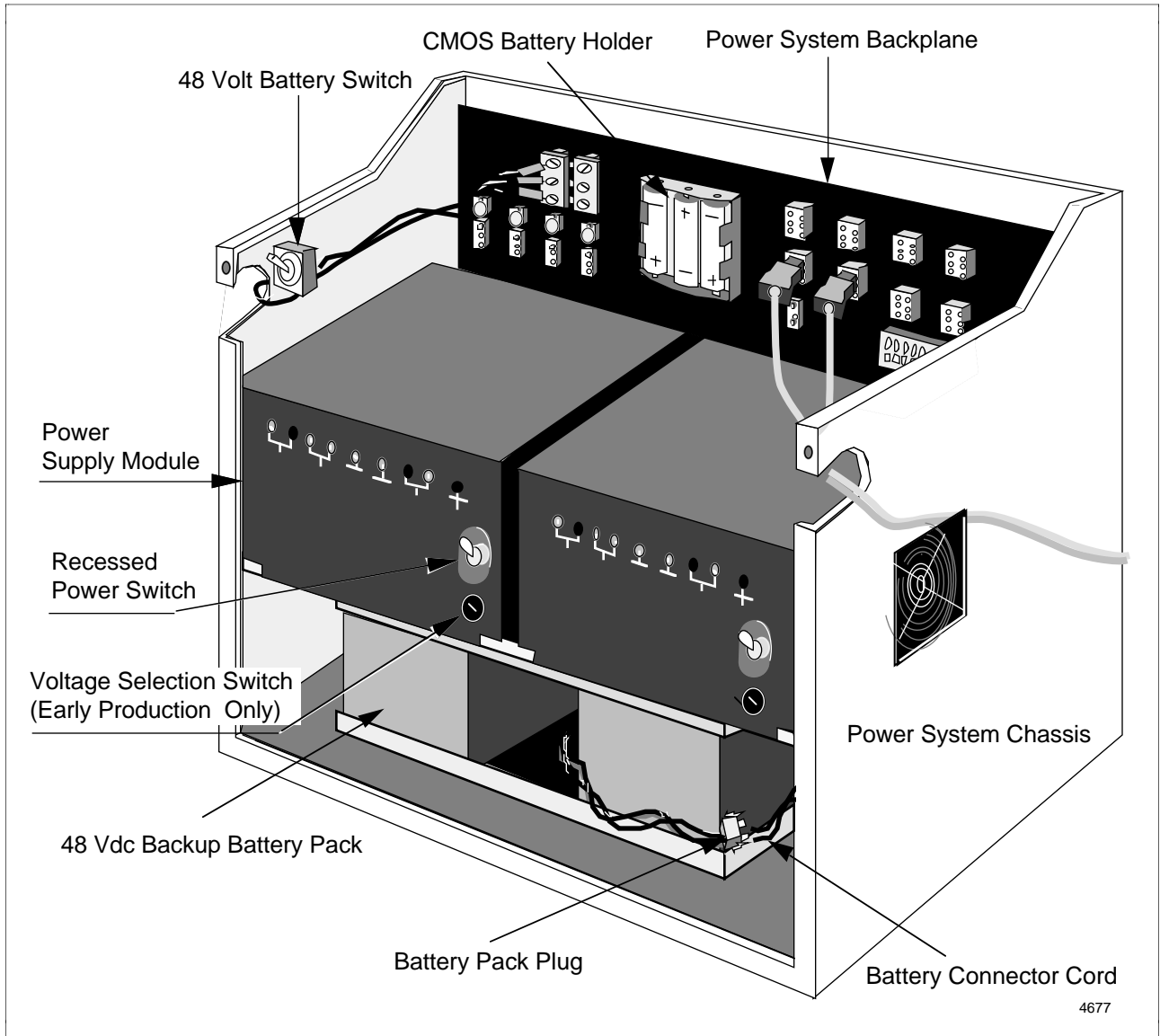

Continued on next page

2.6 Power Systems, Continued

Model MU-PSRX04 Standard Power System

The layout of the model MU-PSRX04 Standard Power System is illustrated in Figure 2-22.

Figure 2-22 Standard Power System—Model MU-PSRX04

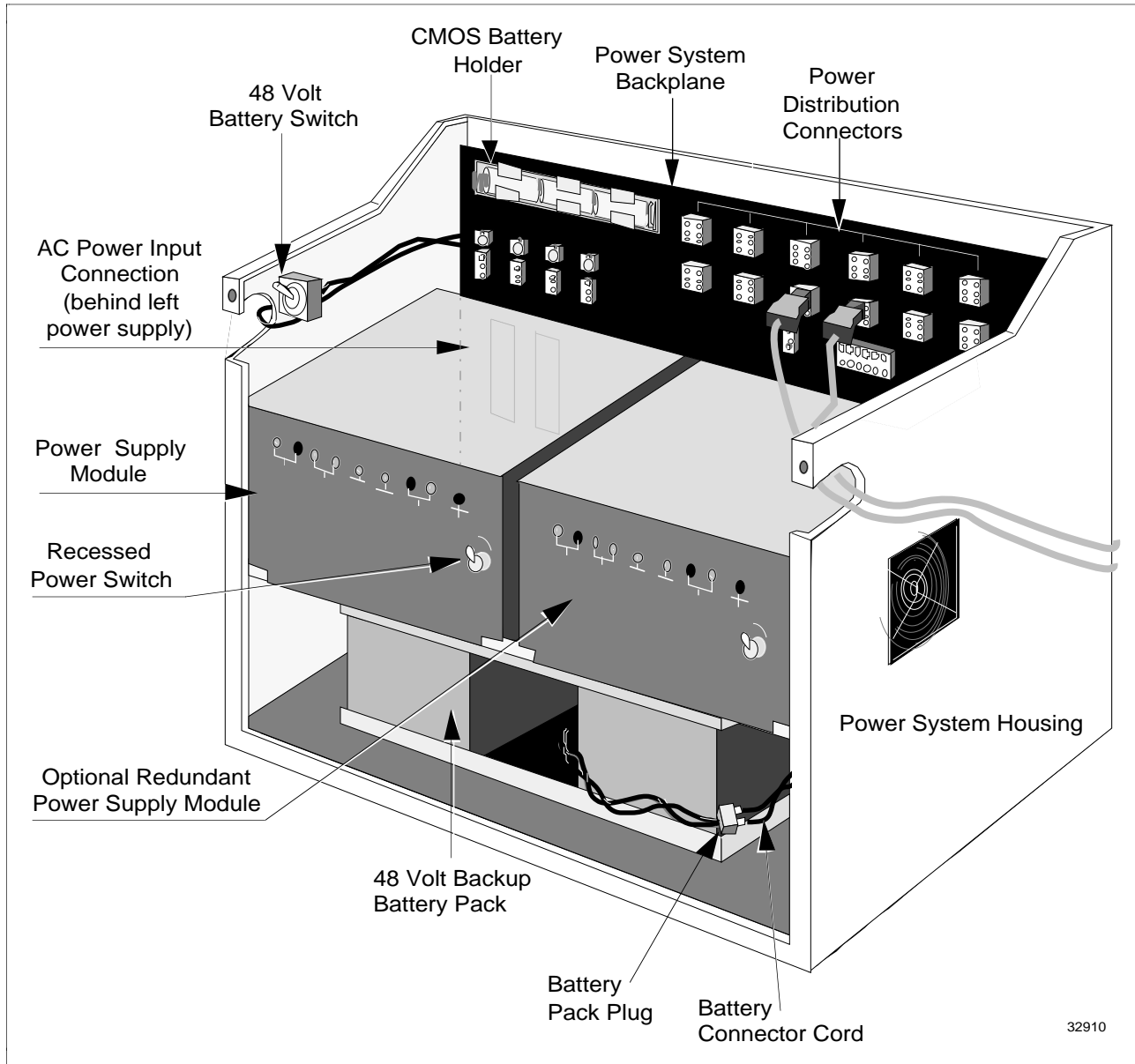

Continued on next page

2.6 Power Systems, Continued

AC Only Power System The AC Only Power System does not offer the optional 48 Vdc Battery Backup module feature and rechargeable NiCad CMOS memory backup power.

Alkaline batteries are used instead of rechargeable NiCad batteries for CMOS data retention in the AC Only Power System.

ATTENTION

ATTENTION—The AC Only Power System must not be used in CE Compliant applications.

Continued on next page

2.6 Power Systems, Continued

AC Only Power System illustration The layout of the AC Only Power System is illustrated in Figure 2-23.

Figure 2-23 AC Only Power System—Not for CE Compliant Applications

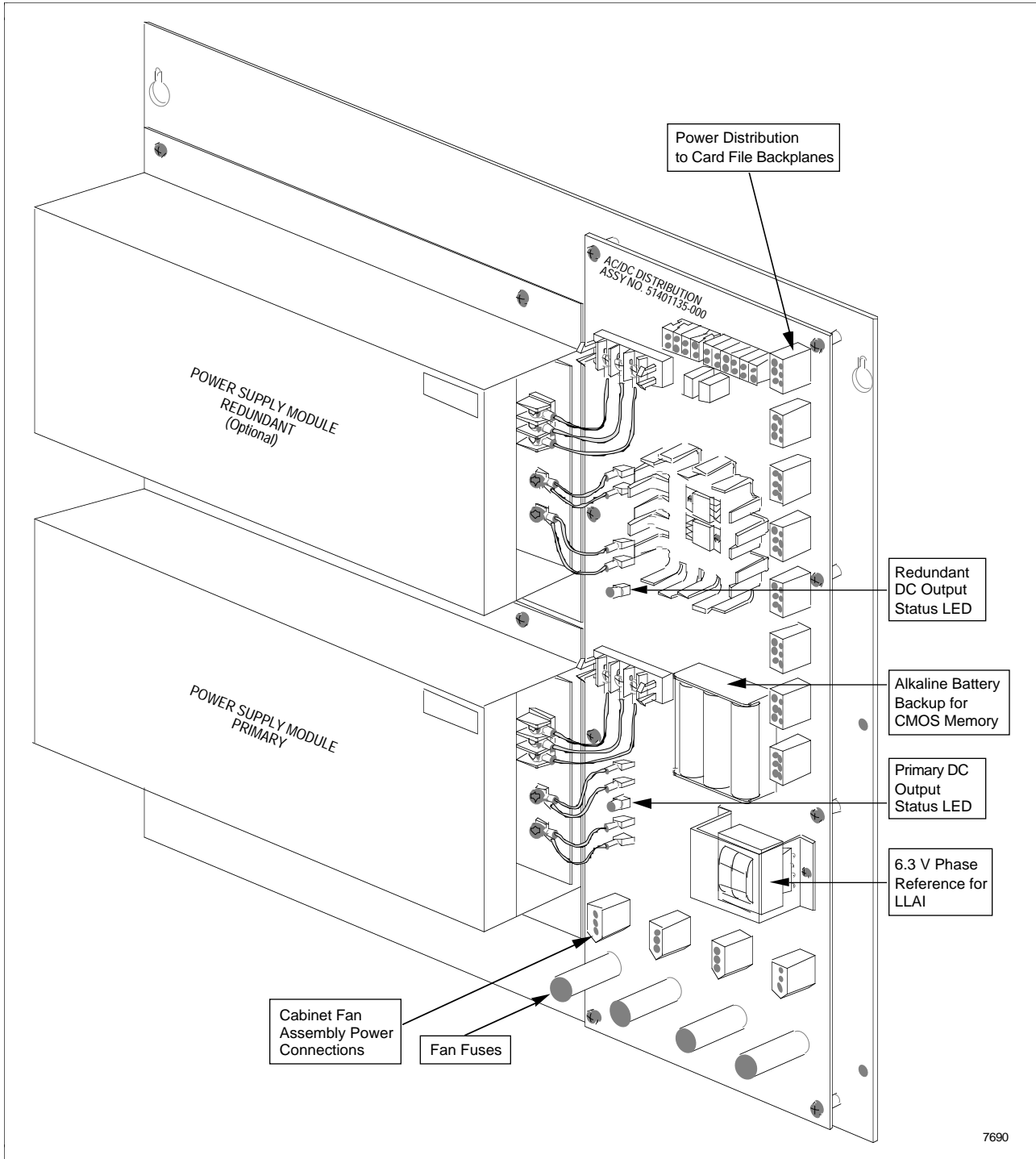

2.7 Cabinet Configurations

Cabinet configurations The Process Manager or Advanced Process Manager subsystem can have various cabinet configurations. Cabinets can be complexed together or remotely separated. The PMM/APMM and IOP card files can share the same Power System or have independent Power Systems.

Continued on next page

2.7 Cabinet Configurations, Continued

Single cabinet

Figure 2-24 is an illustration of a single Process Manager or Advanced Process Manager cabinet containing two single PMM/APMM card files in a redundant PMM or APMM configuration and one IOP card file. The PMM/APMM card files and the IOP card file share the same Power System.

Figure 2-24 Single Cabinet with Redundant PMMs or APMMs

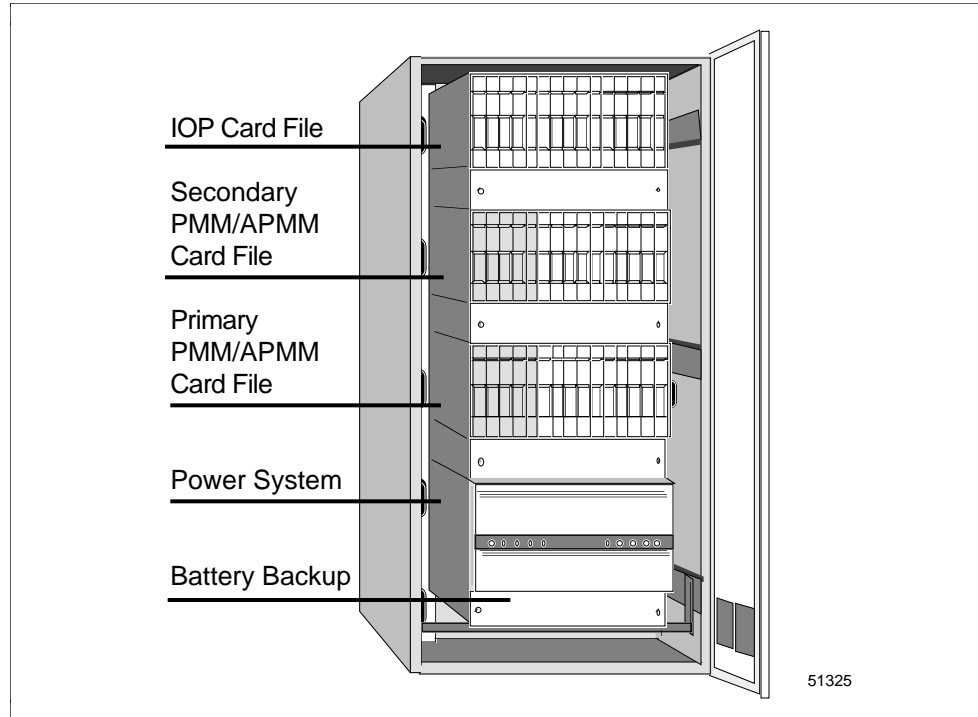

Continued on next page

2.7 Cabinet Configurations, Continued

Complexed cabinets

Two cabinets that are complexed together is illustrated in Figure 2-25. The redundant pair of PMM/APMM card files are installed in separate cabinets. The purpose is to provide independent power for the PMM/APMM card files and their associated IOP card files.

Figure 2-25 Dual Cabinet with Redundant PMMs or APMMs

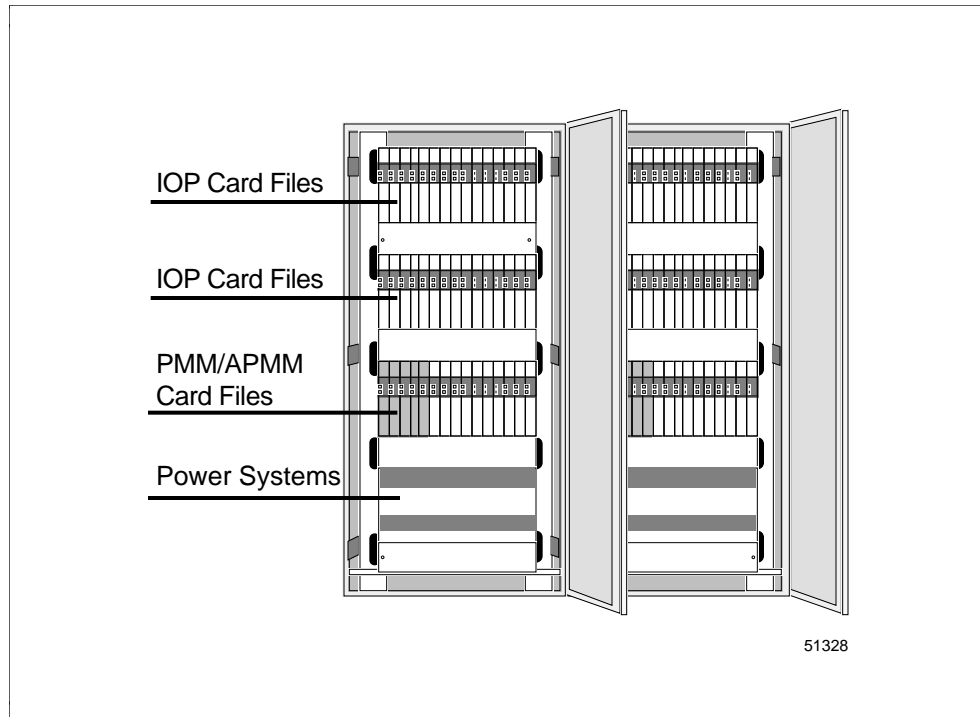

Continued on next page

2.7 Cabinet Configurations, Continued

Local and remote PM or APM cabinets

Figure 2-26 illustrates a 2-cabinet complex with separate redundant PMM/APMM card files and a single remote cabinet that contains only IOP card files. Communication with the remote cabinet is provided by fiber optic I/O Link Extenders.

Figure 2-26 Dual Cabinet with Redundant PMMs or APMMs with Remote I/O Cabinet

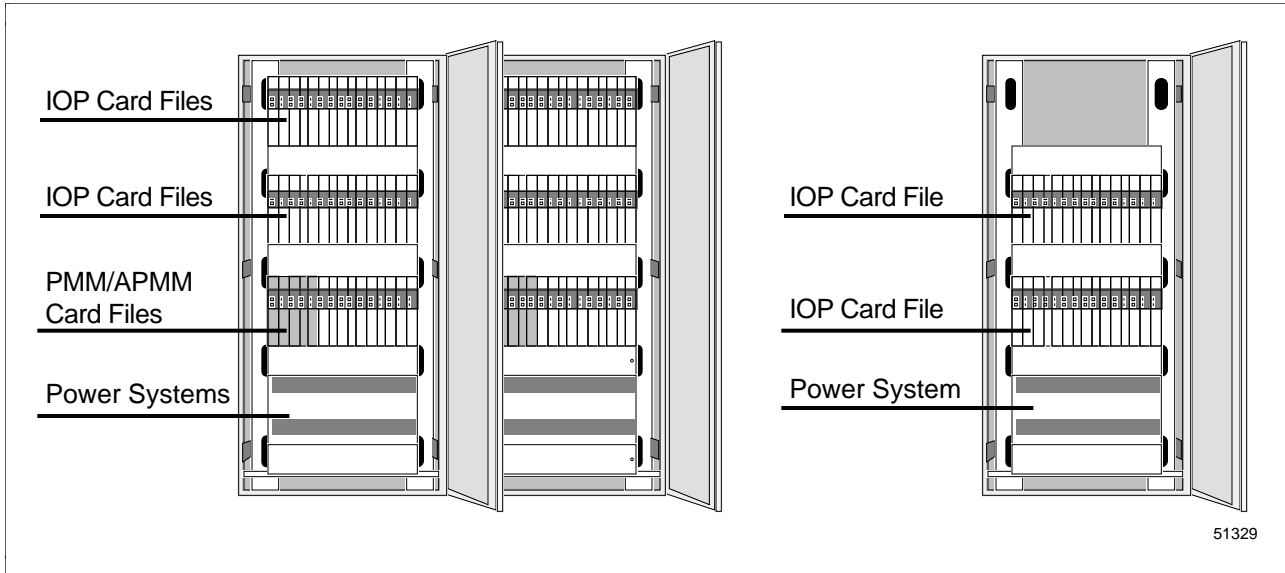

Section 3 – Power Requirements

3.1 Overview

Section contents The topics covered in this section are:

	Topic	See Page
3.1	Overview.....	41
3.2	Backup Strategy.....	42
3.3	Quality.....	44
3.4	Power Draw.....	47
3.4.1	Typical 24 Vdc Power Draw Calculations.....	48
3.4.2	Single Power System Calculation Example.....	53
3.4.3	Dual Power System Calculation Example.....	54
3.4.4	PM/APM AC Power Draw.....	55
3.4.5	Crest Factor.....	57
3.4.6	Inrush.....	60
3.5	Substation Sizing.....	61
3.6	Breaker Sizing.....	62
3.7	Custom UPS and Power Factor.....	62
3.8	Automatic Bypass Switch.....	63
3.9	Surge Protection.....	63
3.10	Grounded Conductor.....	64
3.11	Redundant Safety Grounds.....	64
3.12	Emergency Shutdown.....	64
3.13	Trays and Conduits.....	64
3.14	Existing TDC 3000 ^X AC Power.....	65

Introduction This section provides the user with information to plan adequate ac power service for his Process Manager (PM) or Advanced Process Manager (APM) subsystem. The section also aids the user in planning a power backup strategy when the primary source fails.

Power backup planning A well planned power system for the Process Manager or Advanced Process Manager minimizes subsystem downtime. In this section, we explore various paths for handling the loss of subsystem ac power. The selected path dictates whether a given PM or APM needs the optional dual Power Supply Modules and/or a battery backup for the 24 Vdc. This definition of the power equipment in a PM or APM allows the ac power system requirements to be defined in detail.

3.2 Backup Strategy

Planning strategy	<p>There are several planning strategies for handling a loss of ac power to the PM or APM. This strategy takes advantage of any or all of the following.</p> <ul style="list-style-type: none">• An optional battery backup for the 24 Vdc• An optional secondary Power Supply Module• An optional automatic ac transfer switch• An Uninterruptible Power Supply (UPS)
Power continuity	<p>Power continuity is established by the use of the optional battery backup for 24 Vdc. This battery backup option is available with the redundant Power Supply Module option. When an ac power loss occurs, the battery carries a full load of 20 amperes for minimum of 25 minutes. If 25 minutes is not sufficient, consider another backup source to provide ac power.</p>
Two ac power sourcing methods	<p>There are two methods by which two separate sources of ac power for a PM or APM subsystem can be implemented.</p>
First method	<p>The first method takes advantage of the PM's or APM's redundant Power Supply Module option. The two Power Supply Modules can be wired to operate from two separate ac feeder sources as illustrated in Figure 3-1 or 3-2. The two ac feeder sources do not have to be of the same phase, frequency, voltage, or from the same service as long as each meets the power quality requirements discussed in subsection 3.3.</p>
Second method	<p>The second method, by which two ac feeder sources can be implemented, is through an automatic transfer switch. The PM or APM does not need redundant Power Supply Modules or dual ac feeders for this approach because the transfer switch provides only one ac output. The automatic transfer switch can detect an ac failure and execute a transfer of its load from one service to another in 5 milliseconds. The PM or APM will perform without compromise even if this cycle requires 10 milliseconds.</p>
Better continuity of PM or APM power	<p>The use of the battery backup option in a PM or APM with redundant Power Supply Modules further enhances the continuity of power.</p>

Continued on next page

3.2 Backup Strategy, Continued

Uninterruptible Power Supply (UPS)

A second source of ac power can come from a public utility, another plant, or can be generated from an Uninterruptible Power Supply (UPS). In any case, an automatic or manual transfer switch is needed to complete the installation. Consider the case in which a nearby public utility ac feeder provides backup for the process facility steam plant. An automatic transfer switch should be installed to transfer from the steam plant's ac feeder to the public utility's ac feeder. A switch with maximum transfer time of 10 ms in both directions is recommended. The UPS offers even more possibilities.

UPS description

The UPS consists of a battery charger, a large battery, and a chopper to convert the battery's dc power into quality ac power. The UPS is always on and is always supplying power to its load through the battery, which is on a float charge. Should the ac input fail, the UPS continues to serve the load without any changes and it will continue to operate until the battery is discharged or the ac input to the UPS charger is restored. The capacity of the battery pack is specified by the UPS manufacturer and will provide many hours of backup.

UPS transfer switches

The UPS usually has two transfer switches. A switch on the output of the UPS automatically transfers the loads to plant power in case of failure in the UPS. A second transfer switch to the UPS input charger allows manual transfer to public utility power if there is extended failure of plant power. A UPS with two ac sources provides the means for several backup strategies. The PM or APM offers additional permutations with its optional redundant Power Supply Modules, dual-feeds, and battery backup. The need for all of this backup redundancy depends on how important it is to have a working control system when plant power is out for an extended period.

Power quality

After the overall power system strategy is selected, the quality and the quantity of power must next be determined.

3.3 Quality

Quality requirements

The PM/APM is typically connected to ac power as illustrated in Figure 3-1 or 3-2. It operates on any ac source that meets the following requirements.

- Voltage: 100-132/187-264 Vac, single phase
- Frequency: 47-63 Hz
- Total Harmonic Distortion (THD): 8% maximum
- Power dropout: 10 ms maximum
- Impulse: 2 x line for 10 ms once/hour, 3 kV for 8 x 20 microseconds twice/minute, maximum
- Surge: IEEE Standard 472-1976, ANSI C37.90 a -1974, full compliance

Verification

Techniques and equipment for verifying the above electrical power system parameters are described in the *Process Manager/Advanced Process Manager Checkout* manual. Existing instrument power at most sites usually meets the above requirements.

Continued on next page

3.3 Quality, Continued

AC power and ground Figure 3-1 illustrates the ac power and ground connections for a typical multiground PM or APM installation that includes Master Reference Ground (MRG). The ground system is non-CE Compliant.

Figure 3-1 Subsystem AC Power and Ground Connections—Multiground System

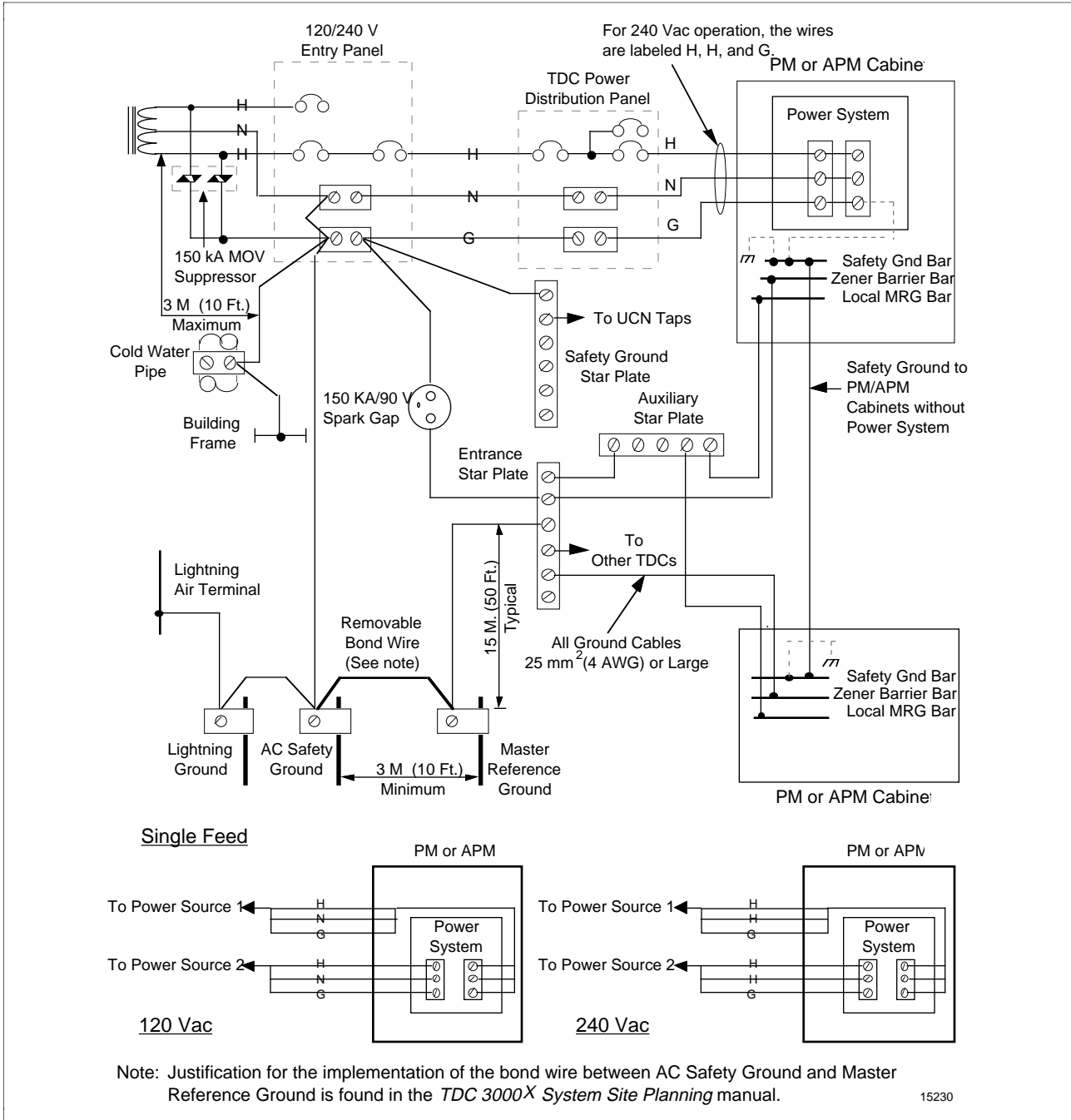

Continued on next page

3.3 Quality, Continued

AC power and ground Figure 3-2 illustrates the ac power and ground connections for a typical single-ground PM or APM installation that is designated Safety Ground. The Safety Ground system is CE Compliant.

Figure 3-2 Subsystem AC Power and Ground Connections— Single-Ground System

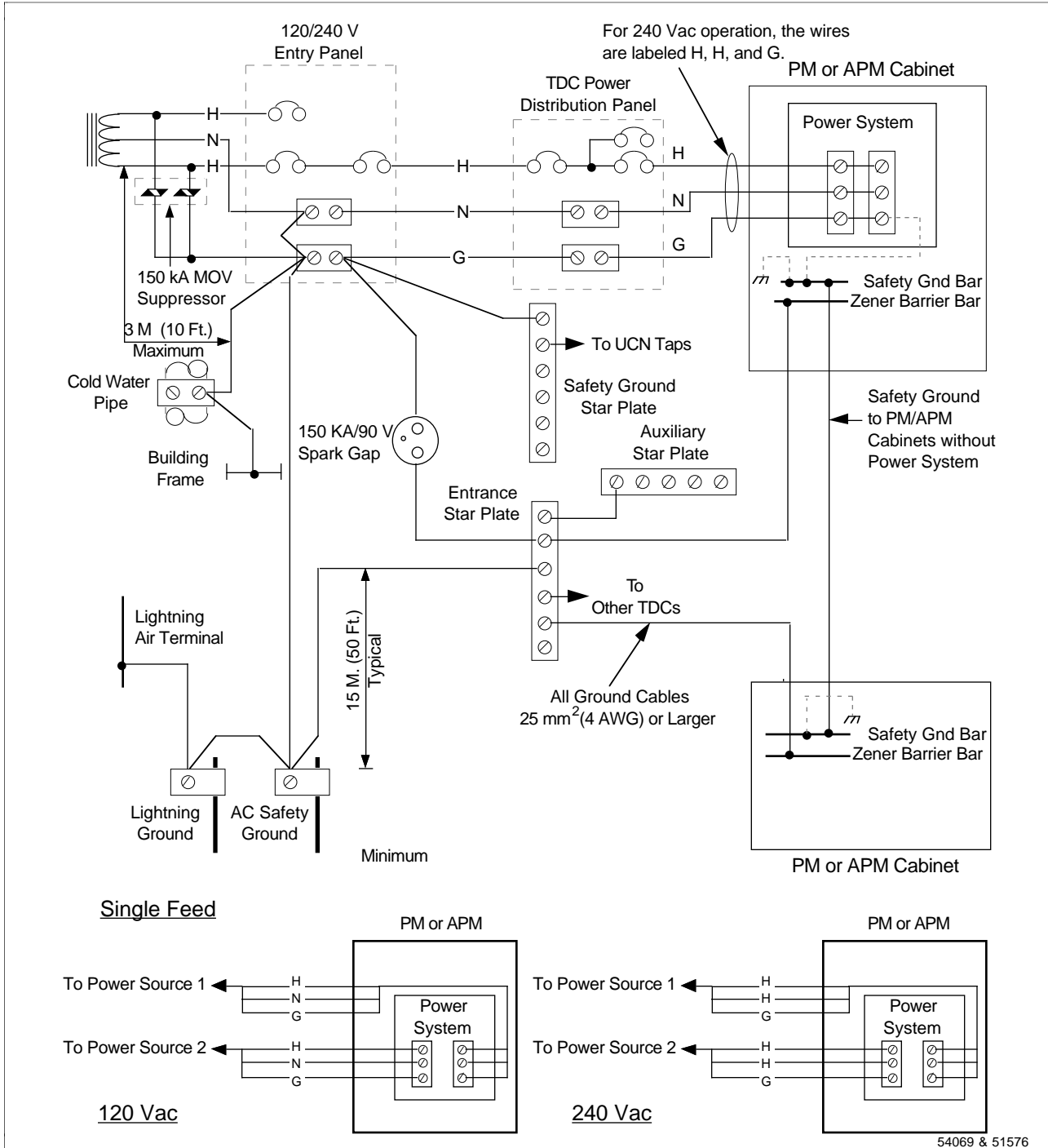

3.4 Power Draw

Introduction

The power requirements for a Process Manager (PM) or Advanced Process Manager (APM) can necessitate the installation of one or more Power Systems in a cabinet complex. This requirement depends on the number and types of Process Manager Modules (PMMs) or Advanced Process Manager Modules (APMMs), Input Output Processors (IOPs), and Field Termination Assemblies (FTAs) in the subsystem. In a large Process Manager or Advanced Process Manager subsystem with redundant PMMs or APMMs and redundant IOPs, it may be desirable to install the PMMs or APMMs in separate cabinets with a Power System in each cabinet. With this configuration, a power failure in one Power System does not result in the failure of both the primary and secondary PMMs or APMMs and IOPs.

Power loading and initial inrush

Other considerations are the nonlinear loading and initial inrush that the Power System subassembly applies to the ac source when power is applied. Each Power System's load requirements must be examined as a function of the options that are installed in the Process Manager or Advanced Process Manager. These demands are discussed in the *TDC 3000^X System Site Planning* manual.

Power System considerations

Each Power System can provide up to 20 A of 24 Vdc power. By calculating the total current requirement, you can determine how many Power Systems are required. If more than one Power System is required, it may be desirable to connect each Process Manager Module (PMM) or Advanced Process Manager Module (APMM) to a separate Power System. It may also be desirable to connect the "A" IOP and "B" IOP of a redundant pair to separate Power Systems.

Provide adequate power

Generally, power for a subsystem with redundant PMMs or APMMs with up to 35 IOPs can be adequately provided by one Power System. A subsystem with redundant I/O may need additional Power Systems. The power calculation is made using the information provided in this subsection.

Subsystems with either remote I/O, or remote cabinets containing one or more IOP card files must be self-contained with at least one Power System.

3.4.1 Typical 24 Vdc Power Draw Calculations

Overview

Two examples of +24 Vdc power requirement calculations are illustrated in subsections 3.3 and 3.4. The **Single Power System Example** assumes a single cabinet with a dedicated Power System. The **Dual Power System Example** assumes a dual cabinet complex with each cabinet having a dedicated separate Power System.

Power calculation procedure

The calculations are based on the power requirements of the assemblies listed in Table 3-1. The current requirements are based on the typical maximum, assuming all channels are in use. Use the following steps to calculate the number of each type of IOP and associated FTA that an individual Power System must support.

1. Determine the number of channels needed for each type of IOP and associated FTA. Divide the total number by the number of channels that are available in the IOP. For example, using Table 3-1, if 256 High Level Analog Input (HLAI) IOP channels are needed, 16 IOPs and FTAs are required ($256 \text{ channels} \div 16 \text{ channels per IOP} = 16 \text{ IOPs and } 16 \text{ FTAs}$).
 2. Multiply the number of IOPs by the current requirement for the type of IOP. For example, 16 model MU-PAIH02 HLAI IOPs require 2928 mA ($16 \text{ HLAI IOPs} \times 183 \text{ mA} = 2928 \text{ mA or } 2.928 \text{ A}$). The current requirement is added to the **Total Module Current** for the Power System.
 3. Multiply the number of FTAs by the current requirement for the type of FTA. For example, 16 model MU-TAIH12/52 HLAI FTAs require 5120 mA ($16 \text{ HLAI FTAs} \times 320 \text{ mA} = 5120 \text{ mA or } 5.12 \text{ A}$). The current requirement is added to the **Total Module Current** for the Power System.
 4. If redundant IOPs are required in the same Power System, double the IOP type count. For example, 16 redundant HLAI channels, A and B, require two IOPs ($16 \text{ channels} \div 16 \text{ channels per IOP} \times 2 = 2 \text{ IOPs}$). When the redundant IOPs reside in separate Power Systems, half the IOP power requirement is added to each Power System's Module Current power requirement (IOP A and IOP B).
 5. To determine the **Total Module Current**, add together the total current for both the IOPs and their associated FTAs. For example, using Table 3-1, 256 HLAI channels require 2928 mA of IOP current and 5120 mA of FTA current ($256 \text{ HLAI channels} = 2928 \text{ mA} + 5120 \text{ mA} = 8048 \text{ mA or } 8.048 \text{ A}$).
-

Continued on next page

3.4.1 Typical 24 Vdc Power Draw Calculations, Continued

Assembly 24 Vdc power usage

Table 3-1 is a list of the power usage for Process Manager or Advanced Process Manager assemblies.

Table 3-1 PM and APM Assembly 24 Vdc Power Usage

Description	Model Number	Channels	Assembly Current (Milliamps)
Single PMM/APMM Card File	MU-PMFX02	N/A	250
Single PMM/APMM Card File	MU-PMFX03	N/A	0
Redundant PMM/APMM Card File	MU-PMFR02	N/A	250
Redundant PMM/APMM Card File	MU-PMFR03	N/A	0
IOP Card File	MU-IOFX02	N/A	0
IOP Card File	MU-IOFX03	N/A	0
Single PMM Card Set	MU-PMMX02	N/A	1120
Redundant PMM Card Set	MU-PMMR02	N/A	2180
Single APMM Card Set	MU-APMS01	N/A	1120
Redundant APMM Card Set	MU-APMR01	N/A	2180
LLAI IOP Card	MU-PAIL02	8	58
LLMux IOP Card	MU-PLAM02	16	70
HLAI IOP Card	MU-PAIH02	16	183
HLAI IOP Card	MU-PAIH03	16	155
STI IOP Card	MU-PSTX02	16	100
STIM IOP Card	MU-PSTX03	16	100
AO IOP Card	MU-PAOX02	8	100
AO IOP Card	MU-PAOX03	8	100
AO IOP Card	MU-PAOY22	16	112
DI IOP Card	MU-PDIX02	32	90
DI IOP Card	MU-PDIY22	32	89
DISOE IOP Card	MU-PDIS11	32	210
DO IOP Card	MU-PDOX02	16	64
DO IOP Card	MU-PDOY22	32	98
PI IOP Card	MU-PPIX02	8	208

Continued on next page

3.4.1 Typical 24 Vdc Power Draw Calculations, Continued

Assembly 24 Vdc power usage, continued

Table 3-1 PM and APM Assembly 24 Vdc Power Usage, Continued

Description	Model Number	Channels	Assembly Current (Milliamps)
SDI IOP Card	MU-PSDX02	2	70
SI IOP Card	MU-PSIM11	2	70
LLAI FTA	MU-TAIL02	8	350
LLMux – RTD FTA	MU-TAMR02	16	185
LLMux – RTD FTA	MU-TAMR03	16	185
LLMux – TC/Local CJR FTA	MU-TAMT02	16	185
LLMux – TC/Local CJR FTA	MU-TAMT03	16	185
LLMux – TC/Remote CJR FTA	MU-TAMT12	16	185
LLMux – TC/Remote CJR FTA	MU-TAMT13	16	185
HLAI/STI FTA	MU-TAIH02	16	320
HLAI FTA	MU-TAIH03	16	320
HLAI/STI FTA	MU-TAIH12/52	16	320
HLAI FTA	MU-TAIH13/53	16	320
HLAI/STI FTA	MU-TAIH22/62	16	320
HLAI FTA	MU-TAIH23	16	320
STI FTA	MU-TSTX03	16	320
STI FTA	MU-TSTX13/53	16	320
AO FTA	MU-TAOX02	8	160
AO FTA	MU-TAOX12/52	8	171
AO FTA	MU-TAOY22/52	16	004
AO FTA	MU-TAOY23/53	16	004
24 Vdc DI FTA	MU-TDID12/52	32	408
24 Vdc DI FTA	MU-TDID72	32	410
24 Vdc Power Distribution Assembly	MU-TDPR02	12	200
24 Vdc DI FTA	MU-TDIY22/62	32	004

Continued on next page

3.4.1 Typical 24 Vdc Power Draw Calculations, Continued

Assembly 24 Vdc power usage,
continued

Table 3-1 PM and APM Assembly 24 Vdc Power Usage, Continued

Description	Model Number	Channels	Assembly Current (Milliamps)
120 Vdc DI FTA	MU-TDIA12/52	32	192
120 Vdc DI FTA	MU-TDIA72	32	200
240 Vdc DI FTA	MU-TDIA22/62	32	192
24 Vdc Nonisolated DO FTA	MU-TDON12/52	16	0
24 Vdc Isolated DO FTA	MU-TDOY22/62	32	004
3-30 Vdc Solid-State DO FTA	MU-TDOD12/52	16	160
3-30 Vdc Solid-State DO FTA	MU-TDOD13/53	16	160
3-30 Vdc Solid-State DO FTA	MU-TDOD14/54	16	160
31-200 Vdc Solid-State DO FTA	MU-TDOD22/62	16	160
5-200 Vdc Solid-State DO FTA	MU-TDOD23/63	16	160
24-240 Vac Solid-State DO FTA	MU-TDOA12/52	16	160
120/240 Vac Solid-State DO FTA	MU-TDOA13/53	16	160
120 Vac/125 Vdc Relay DO FTA	MU-TDOR12/52	16	470
240 Vac/125 Vac Relay DO FTA	MU-TDOR22/62	16	470
240 Vac/125 Vac Relay DO FTA	MU-TDOY23/63	16	228
PI FTA	MU-TPIX12/52	8	136
SDI FTA – Toledo Scale Cell	MU-TSDT02	1	65
SDI FTA – Manual/Auto Station	MU-TSDM02	1	65
SDI FTA – UDC6000	MU-TSDU02	1	65
Manual/Auto Station	MU-MASX02	N/A	800
SI FTA – Allen-Bradley	MU-TSIA12	1	65
SI FTA – Modbus	MU-TSIM12	1	65
Power Adapter (LLMux, SDI, SI FTAs)	MU-TLPA02	2	360
Galvanically Isolated HLAI FTA	MU-GAIH12/82	16	1200
Galvanically Isolated HLAI/STI FTA	MU-GAIH13/83	16	1200

Continued on next page

3.4.1 Typical 24 Vdc Power Draw Calculations, Continued

Assembly 24 Vdc power usage, continued

Table 3-1 PM and APM Assembly 24 Vdc Power Usage, Continued

Description	Model Number	Channels	Assembly Current (Milliamps)
Galvanically Isolated HLAI/STI FTA	MU-GAIH14/84	16	1200
Galvanically Isolated HLAI FTA	MU-GAIH22/92	16	1200
Galvanically Isolated AO FTA	MU-GAOX02/72	8	440
Galvanically Isolated AO FTA	MU-GAOX12/82	8	440
Galvanically Isolated 24 Vdc DI FTA	MU-GDID12/82	32	800
Galvanically Isolated 24 Vdc DI FTA	MU-GDID13/83	32	800
Galvanically Isolated 24 Vdc DO FTA	MU-GDOD12/82	16	1800
Galvanically Isolated 24 Vdc DO FTA	MU-GDOL12/82	16	1800
Combiner Panel	MU-GLFD02	N/A	0
Marshalling Panel	MU-GMAR02	N/A	0
Galvanic Isolation Power Distribution Assembly	MU-GPRD02	N/A	160
Long Distance I/O Link Extender Cards/Couplers	MU-ILDX02	N/A	300
Long Distance I/O Link Extender Cards/Couplers	MU-ILDX03	N/A	300
Standard I/O Link Extender Cards/Couplers	MU-IOLM02	N/A	196
Standard I/O Link Extender Cards/Couplers	MU-IOLX02	N/A	190
Analog Output Standby Manual with case	MU-SMAC02	4	250
Analog Output Standby Manual - Digital	51401926-100	8	2200
Digital Output Standby Manual with case	MU-SMDC02	16	70
Digital Output Standby Manual without case	MU-SMDX02	16	100

3.4.2 Single Power System Calculation Example

Power calculation example

The following example in Table 3-2 meets the requirement that the total calculated current for an individual Power System is no greater than 20 amperes.

Table 3-2 Single Power System Calculation Example

Assemblies	Total IOP/Module Current	Total FTA Current
Redundant APMMs	2.180 A	N/A
High Level Analog Input (HLAI) IOPs, nonredundant (256 channels ÷ 16 channels/IOP = 16 IOPs x 183 mA = 2928 mA) (16 FTAs x 320 mA = 5120 mA)	2.928 A	5.120 A
High Level Analog Input (HLAI) IOPs, redundant A & B (16 channels x 2 = 32 channels ÷ 16 channels/IOP = 2 IOPs x 183 mA = 366 mA) (1 FTA x 320 mA = 320 mA)	0.366 A	0.320 A
Analog Output (AO) IOPs, nonredundant (120 channels ÷ 8 channels/IOP = 15 IOPs x 100 mA = 1500 mA) (8 FTAs x 171 mA = 1368 mA)	1.500 A	1.368 A
Analog Output (AO) IOPs, redundant A & B (16 channels x 2 = 32 channels ÷ 8 channels/IOP = 4 IOPs x 100 mA = 400 mA) (2 FTAs x 171 mA = 342 mA)	0.400 A	0.342 A
Subtotals	7.374 A	7.150 A

Total Power System Current = 7.374 + 7.150 = 14.524 A

3.4.3 Dual Power System Calculation Example

Calculation examples The following examples in Table 3-3 and 3-4 meet the requirement that the total calculated current for an individual Power System is no greater than 20 amperes.

Power System 1 calculation

Table 3-3 Dual Power System Calculation Example (Power System 1)

Power System 1		
Assemblies	Total IOP/Module Current	Total FTA Current
Single APMM	1.120 A	N/A
High Level Analog Input (HLAI) IOPs, nonredundant (80 channels ÷ 16 channels/IOP = 5 IOPs x 183 mA = 915 mA) (16 FTAs x 320 mA = 5120 mA)	0.915 A	1.600 A
High Level Analog Input (HLAI) IOPs, redundant A (240 channels = 16 channels/IOP = 15 IOPs x 183 mA = 2740 mA) (15 FTA x 320 mA = 4800 mA)	2.740 A	4.800 A
Analog Output (AO) IOPs, nonredundant (40 channels ÷ 8 channels/IOP = 5 IOPs x 100 mA = 500 mA) (5 FTAs x 171 mA = 855 mA)	0.500 A	0.855 A
Analog Output (AO) IOPs, redundant A (120 channels ÷ 8 channels/IOP = 15 IOPs x 100 mA = 1500 mA) (15 FTAs x 171 mA = 2565 mA)	1.500 A	2.565 A
Subtotals	6.765 A	9.820 A

Total Power System 1 Current = 6.765 + 9.82 = 16.585 A

Continued on next page

3.4.3 Dual Power System Calculation Example, Continued

Power System 2 calculation

Table 3-4 Dual Power System Calculation Example (Power System 2)

Power System 2		
Assemblies	Total IOP/Module Current	Total FTA Current
Single APMM	1.12 A	N/A
High Level Analog Input (HLAI) IOPs, redundant B (240 channels = 16 channels/IOP = 15 IOPs x 183 mA = 2740 mA) (15 FTA x 320 mA = 4800 mA)	2.74 A	4.800 A
Analog Output (AO) IOPs, redundant B (120 channels ÷ 8 channels/IOP = 15 IOPs x 100 mA = 1500 mA) (15 FTAs x 171 mA = 2565 mA)	1.50 A	2.565 A
Subtotals	5.36 A	7.365 A

$$\text{Total Power System 2 Current} = 5.36 + 7.365 = 12.725 \text{ A}$$

3.4.4 PM/APM AC Power Draw

Introduction

Using the hardware's current requirements and number of Power Systems, the subsystem's ac power, substation sizing requirement, and heat generation can be calculated.

Power loss calculation

To complete the information needed to accomplish the above calculation, the Power System loss, P_L , is calculated using the output power, P_O .

$$P_L = 0.31 P_O + 38 \text{ watts}$$

Maximum power requirements

At certain facilities, it may be better to provide power for the limit of the PM or APM Power System, rather than to design for existing hardware configuration. In this case, a fully loaded Power System that is running at 20 amperes, plus the battery, has a worst case line draw of 7.6 amperes ac rms at 120 Vac with a Crest Factor of 1.1. A Power System with no load, such as the secondary Power Supply Module in the PM or APM, has a worst case line draw of 1 ampere ac rms at 120 Vac with a Crest Factor of 1.0. When operating at 240 Vac, halve the current requirement.

Continued on next page

3.4.4 PM/APM AC Power Draw, Continued

AC power draw calculation example

Consider the following ac power draw calculations for typical APM subsystem.

Component	Component Draw	Field Load (Milliamps)	Net (Milliamps)
APMM (2)	2180		2180
MU-TAIH02 (1)	183		503
MU-TAOX02 (1)	235		235
MU-TDON12 (1)	64	100 x 16 = 1600	1600
MU-TDOD12 (3)	64 x 3 = 192	1800 x 3 = 5400	6072
MU-TDID12 (6)	89 x 6 = 534	13 x 192 = 2496	<u>6072</u>
Total Current:			15412

24 Vdc Power Wattage: $15.412 \text{ A} \times 24 \text{ Vdc} = 369.9 \text{ W}$

48 Vdc Battery Backup Charge Wattage Requirement: $1.0 \text{ A} \times 48 \text{ Vdc} = \underline{48.0 \text{ W}}$

Total Power System Output Wattage: 417.9 W

APM Power System losses are characterized by the equation: $P_L = 0.31 \text{ PO} + 38 \text{ watts}$

For a Power System loaded with 417.9 watts, the loss is: $0.31 \times 417.9 + 38 = \underline{167.6 \text{ W}}$

Total Wattage Supplied to the Power System: 585.5 W

The APM has two Power Supply Modules.

The redundant Power Supply Module has a no load calculated loss of: $0.31 \times 0 + 38 = \underline{38.0 \text{ W}}$

Total ac wattage input to the two 24 Vdc Power Supply Modules: 623.5 W

The Power System has a power factor of 0.8 over a broad range. Assume for this example a power factor of 0.8 for Power Supply Module and that both are on the same ac line feeder.

The ac line feed current calculation is $0.8 \text{ pf} \times 120 \text{ Vac} \times I = 623.5 \text{ W}$
 $I = 6.49 \text{ A}$

For this example, do not forget that the 3-30 Vdc Solid State Digital Output FTA probably has a 48 volt supply somewhere, and therefore has other ac requirements.

3.4.5 Crest Factor

Introduction

An electronic Power Supply Module that is used in the PM, APM, or the LCN presents a nonlinear load to an ac source as illustrated in Figure 3-3 (b). The current draw is in short pulses rather than sinusoidal. A substation or Uninterruptible Power Supply (UPS) must be sized for repetitive peak current. Otherwise, the voltage will collapse during each peak and distort its sinusoidal wave shape.

Nonlinear-load Power Supply Module

The nonlinearity of the electronic Power Supply Module is reflected in its published Crest Factor as follows.

Theory

A resistive or reactive load on an ac source creates a proportional linear loading as illustrated in Figure 3-3 (a). Rectifiers in electronic loads cause power to be pulled in short pulses. See Figure 3-3 (b). This pulse loading requires over-sizing of the substation.

Linear load peak-current calculation example

For an example of a linear load peak-current calculation, use one volt with a one ampere ac rms linear load. The Crest Factor for a linear load is $\sqrt{2}$, which equals 1.414. This load has a repetitive peak demand on the substation that is calculated as follows:

- The load VA is: 1 volt x 1 ac rms ampere = 1 volt-ampere
 - The substation peak loading is: one ampere x $\sqrt{2}$ = 1.414 amperes
-

Nonlinear load peak-current calculation example

For an example of a nonlinear load calculation, use one volt and a one ampere ac rms nonlinear load with a Crest Factor of 1.1. This loading has a repetitive peak loading on the substation that is calculated as follows:

- The load VA is: 1 volt x 1 ac rms ampere = 1 volt ampere
 - For a load Crest Factor of 1.1, the substation peak load is 1 ampere x 1.1 Crest Factor = 1.1 amperes peak
-

Comparing linear and nonlinear loads

Comparing this calculation with the preceding calculation, it is seen that a nonlinear load can draw current peaks that are more than twice as large as those for the linear load.

Substation transformer scaling

Scaling the substation transformer to handle peak rather than rms current prevents a distortion problem. The breakers and conductors are still sized by using rms figures.

Continued on next page

3.4.5 Crest Factor, Continued

Crest Factor

Figure 3-3 Crest Factor

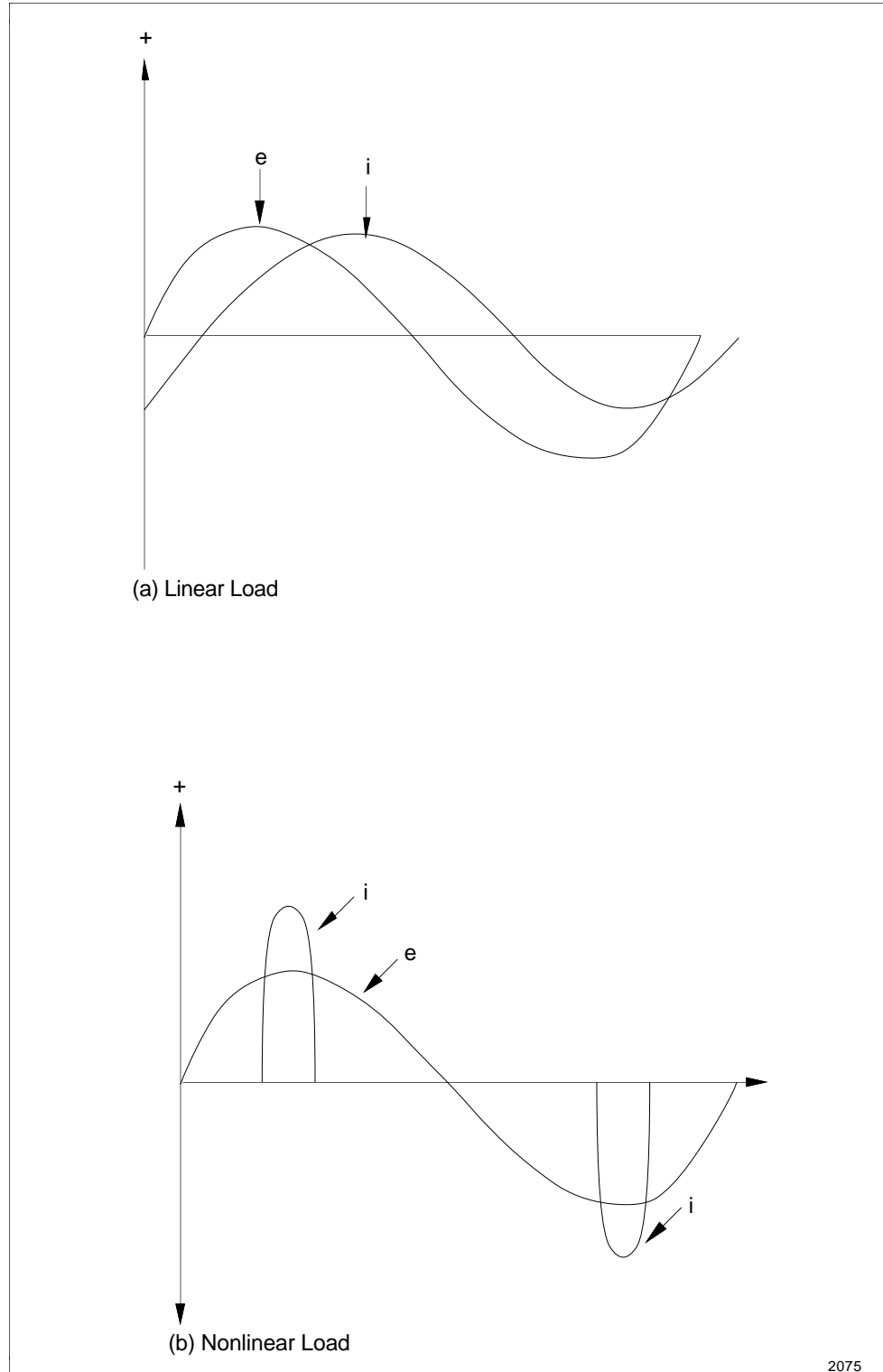

3.4.5 Crest Factor, Continued

Aggregate Crest Factor calculation Different Power Systems in a room may be running at different Crest Factors. To size the substation transformer or UPS, you must calculate a Crest Factor for the aggregate. An example follows.

First example A PM or APM with redundant Power Supply Modules is the first example of calculating a Crest Factor for two loads together.

The primary Power Supply Module is assumed to be running at full load and the secondary Power Supply module at no load.

The fully loaded Power Supply Module is specified for a worst case draw on the ac power line of 7.6 amperes ac rms with a Crest Factor of 1.1. The secondary Power Supply Module is specified for a worst case draw on the ac line of 1 ampere ac rms with a Crest Factor of 1.0.

Power Supply Module	RMS Draw (Amperes)	Crest Factor	Peak Draw (Amperes)
Primary	7.6	1.1	$7.6 \times 1.1 = 8.36$
Secondary	<u>1.0</u>	1.0	$1.0 \times 1.0 = \underline{1.00}$
Totals	8.6		9.36

From the above calculations, the total loading is 8.6 amperes ac rms with a Crest Factor of 1.09 ($9.36 \text{ amperes peak} \div 8.6 \text{ amperes rms} = 1.09$).

Second example A second example of an aggregate Crest Factor calculation is given in subsection 3.5. This example is for a mix of Local Control Network (LCN) Operator Stations, PMs, and APMs.

3.4.6 Inrush

Introduction

This discussion assumes the Power Supply Module is set for 120 Vac operation. Halve the currents for 240 Vac operation.

When power is initially applied

When power is initially applied, the PM or APM Power System has a worst case instantaneous peak Inrush of 85 amperes that then declines to 27 amperes peak in two milliseconds, after which it declines to the normal operating repetitive peak within five cycles. Because the 85 ampere peak is so short, the following discussion uses the 27 ampere peak for design purposes.

Two Power Supply Modules on one breaker will draw twice as much current.

Solving the Inrush problem

A substation or UPS can handle the Inrush current by using one of several methods:

- When powering up a large system with many devices, the surge is large and the ac source may take 10 cycles or more to reach specifications; however, because the system is not operational, a slow power-up is not important.
- A substation transformer or a UPS may already include an inherent surge allowance, such as a 50% overload capability while meeting all other specification requirements.
- A larger substation can be purposely selected to include the Inrush as steady state current. For example, applying power to a redundant PM or APM Power System creates an Inrush of 54 amperes peak. Because the redundant Power Supply Modules already requires a steady state operating current of 8.6 amperes ac rms with a Crest Factor of 2.09, the substation already provides $(8.6 \times 2.09 =)$ 18 amperes peak. Therefore, the example substation needs to be increased in size by $(54 - 18 =)$ 36 amperes peak to handle the surge to service the particular PM or APM Power System.
- When the UPS is too small to provide a workable Inrush capability, it can be split into even smaller units so that each PM or APM has its own unit. As such, servicing a PM or APM may cause a momentary fold-back of its UPS, but the other units are unaffected.

The following discussion on substation sizing considers all the previous current requirements and allows an extra 36 amperes peak for Inrush to service one redundant PM or APM Power Supply Module at a time.

3.5 Substation Sizing

Conversion example

The published current rating for a substation transformer or UPS is created with the assumption that it will be used for a linear load. A linear load has a Crest Factor of $\sqrt{2}$. Because the load Crest Factor for electronic equipment is not $\sqrt{2}$, conversion is required. This is accomplished by converting all the TDC 3000^X system rms amperages to peak values as illustrated in the following example.

Load Description	RMS Draw (Amperes)	Crest Factor	Peak Draw (Amperes)
APMMs (5)	43.0	2.09	43 x 2.09 = 89.9
Operator Console CRTs	<u>35.0</u>	2.27	35 x 2.27 = <u>79.5</u>
Subtotals	78.0		169.4
Future Expansion	x 1.33		x 1.33
APM Inrush Allowance			36.0
Total			261.3

No Inrush allowance for the LCN Operator Console is required. The soft-start power supplies have a maximum Inrush of 10 amperes, so they are easily accommodated by the 36 ampere allowance for the APMs.

The 261.3 ampere peak is derated by $\sqrt{2}$ for the purpose of selecting a transformer. Thus, a 185 ampere ($261.3 \text{ amperes peak} \div \sqrt{2}$) linear-load handling capacity transformer is required. In other words, it is now known that a 185 linear-ampere ac rms transformer can deliver the required 261.3 ampere peaks.

You will need a 22,200 VA (120 V x 185 A) transformer, either for 120 V, 240 V, or 208 V line-to-line grounded Y. Conductors and breakers are sized using the 103.7 amperes rms calculation.

Substation and UPS requirements

As previously calculated, an off-the-shelf substation or UPS must have a Volt-Amperes (VA) capacity that is significantly greater than the rms total for the load. A custom-designed substation or UPS can be designed so that the peak and RMS requirements for electronic loads coincide. Significant economies are possible. See subsection 3.7.

3.6 Breaker Sizing

Ac feeder	For a PM or APM with one 24 Vdc Power Supply Module, one ac feeder is used. With two Power Supply Modules, one or two feeders can be used. See Figure 3-1 or 3-2.
Circuit breakers	The ac feeder conductors require current limiting for protection. Circuit breakers used for this purpose are to be sized for the ac rms current and are not to be adjusted for the Crest Factor.
One Power Supply Module	A PM or APM with one 24 Vdc Power Supply Module requires that one ac feeder has a worst case ac line draw of 7.6 amperes ac rms. Local electrical codes usually require that the feeder breaker be sized at 125% of its noncontinuous-plus-continuous load. The ac feeder requires a 10-ampere breaker. This is the nearest common size that gives a 125% oversizing allowance.
Two Power Supply Modules	For a PM or APM with two 24 Vdc Power Supply Modules on one ac feeder, the total worst case draw is 8.6 amperes ac rms; therefore, a 12-ampere breaker is required.
Two Power Supply Modules on two ac feeders	For a PM or APM with two Power Supply Modules on two ac feeders, either Power Supply Module can draw 7.6 amperes ac rms, or there can be some random proportioning. As such, each feeder needs a 10-ampere breaker. When using two Power Systems for one PM or APM, two ac feeders are required. Both Power Systems should be connected to both ac feeders.
ATTENTION	ATTENTION—Do not use a breaker larger than 15 amperes. The Power System wiring is not rated to handle a larger feeder.

3.7 Custom UPS and Power Factor

Introduction	Frequently, the UPS and substation components are designed specifically for each installation. Significant economies are possible by specifying the load as thoroughly as possible. The designers will then optimize the design for the exact combination of ac rms current, repetitive peak current, Inrush, and distortion.
Power Supply Module power factor	Each PM or APM Power Supply Module has a power factor of 0.8 over a broad range of loads. This information is necessary to optimize the harmonic filter in a UPS.

3.8 Automatic Bypass Switch

Introduction

An automatic bypass switch is often included in the power source to allow instantaneous transfer between two ac sources. Both the primary and backup power sources should be of instrument grade. Transfer to a substandard power source in an emergency does not always happen.

Transfer time requirement

The switch transfer time should be less than 10 milliseconds in both directions. This allows maintenance personnel to freely operate the switch without disturbing the operation. Additional discussion about transfer switches can be found in subsection 3.2.

3.9 Surge Protection

Introduction

Any instrument power distribution panel should have some transient protection. See Figure 3-1 or 3-2.

Protector usefulness

A protector is useful under the following conditions:

- Should an ac feeder develop a short circuit, its breaker may not open until peak currents have reached 10,000 amperes or more. The sudden interruption of such a large current when a breaker opens injects a severe transient into the rest of the electrical system.
 - PM or APM servicing may require that the Power Supply Modules be turned off and on. Even at normal load currents, significant transients may be generated in the distribution panel.
 - Lightning may strike the facility power feeder and send significant transients into the instrument system.
-

Power Supply Module performance

The PM or APM Power Supply Module is rated to perform to all its specifications while handling a variety of transients, such as a 3 kV impulse for 8 x 20 microseconds. This provides a safety factor to allow for feed through when the surge protector operates.

MOV protector

A Metallic Oxide Varistor (MOV) is the preferred power line protector. Compared to a protector based on a spark gap, the MOV protector does not short circuit the power along with the transient. Use a 150 kA unit. Overcapacity here does not carry a penalty.

A suitable protector can be purchased from Lightning Protection Corporation in Santa Barbara, CA at telephone number 805-967-5089. For a 120/240 Vac system, use Model 20208.

3.10 Grounded Conductor

Power source's grounded conductor

The power source to the PM or APM may or may not have a grounded conductor. This does not make any difference to the PM or APM as long as local electrical codes are satisfied.

3.11 Redundant Safety Grounds

Introduction

The electronics in the PM or APM are insulated from its enclosures. The use of metal conduits to the enclosures does not affect operation of the equipment. The placement of cabinets on metal floors, the bonding of the cabinets to metal floor supports, cabinets touching metal structure, or the purposeful installation of redundant safety grounds also does not affect the operation of the equipment.

Reference

Grounding is discussed in the *TDC 3000^X System Site Planning* manual. Grounding also relates to lightning protection, which is also discussed in the *TDC 3000^X System Site Planning* manual.

3.12 Emergency Shutdown

Introduction

Electrical codes may require the ability to shut down system power from principal exit doors. This emergency shutdown requirement is satisfied most economically by placing the instrument power distribution panel within arm's length of the room exit. See the room layout in Figure 2-1.

3.13 Trays and Conduits

Raised floor

Power and signal wiring in the electronics room is easily accommodated by using a raised floor. The space underneath the floor becomes one large wiring tray. Power and signal cables for the PM or APM may be routed together as long as the cabling is approved for the circuits being handled. Contact or relay signals must be in shielded cables to prevent contact arcing from inducing Electromagnetic Interference (EMI) into other signal cables.

Continued on next page

3.13 Trays and Conduits, Continued

FTA cables

The 50-conductor FTA cables may exit the PM or APM cabinets and go to facility terminal panels that incorporate FTAs. This is discussed in detail in the *Process Manager/Advanced Process Manager Installation* manual. The cables have 24 volts from a Class 1 Power Limited source as defined in the National Electrical Code (NEC) in the USA. This usually requires that the FTA cables are installed in their own trays (the connectors are too big to pull through conduit) if they leave the cabinet. The dedicated trays are considered as an extension of the PM or APM cabinet.

Field circuit

Field circuits are different. Most are limited in the FTAs to Class 2 Power Limited source requirements. This allows a great deal of freedom in their installation as discussed in the Section 5 of this manual.

Cable segregation

Refer to the Control Room floor layout in Figure 2-1 for the following discussion. Local codes may require that all wiring be placed in enclosed metal trays or conduit. It is then recommended that the circuits to a PM or APM be segregated into separate trays or compartment as follows:

- Power cables should be placed in one tray/conduit. The need for a cover depends on local codes. All safety ground conductors also use this tray. The ac circuit cables in this tray usually originate at the instrument ac distribution panel.
 - Process signals at 30 volts ac/dc peak or less are routed in their own tray/conduit. This includes 1-5 V/4-20 mA signals, alarm contacts, UCN coaxial cables, and Master Reference Ground (MRG) cables. All signals in the tray usually originate at the 0-30 volt signal terminal panel.
 - Signals above 30 volts, although normally considered as power circuits, should route through their own tray/conduit. All signals in this tray usually originate at the facility 31-250 volt signal terminal panel.
 - FTA cables leaving cabinets usually require their own tray as discussed previously.
-

Intrinsic Safety

Intrinsic Safety systems with zener barriers or current limiting resistors usually require another conduit or tray compartment. This is covered in Section 5 of this manual.

3.14 Existing TDC 3000^X AC Power

Power compatibility

The power required for the PM or APM is compatible with power provided for all other TDC 3000^X Systems. Connect the PM or APM to existing TDC 3000^X power when it is convenient.

Section 4 – Process Wiring

4.1 Overview

Section contents The topics covered in this section are:

	Topic	See Page
4.1	Overview.....	67
4.2	FTA Selection	68
4.3	Cabinet Entry	75
4.4	Signal Tray Wiring Compatibility.....	76
4.5	Process Wiring Termination.....	77

Introduction The process control signal wires connect to the Process Manager (PM) or Advanced Process Manager (APM) at the Field Termination Assemblies (FTAs). The type of FTA selected is dependent upon the process being controlled or monitored. There are 16 types of FTAs to choose from. Some of the FTA types support IOP redundancy. Some of the FTA types provide Galvanic Isolation and are for Intrinsically Safe applications.

FTA mounting The FTAs are installed on FTA Mounting Channels that are located in the front of a single access PM or APM cabinet, and in the rear or front of a dual-access cabinet. The number of FTA Mounting Channels accommodated in a cabinet is dependent upon whether the cabinet is single access or dual access, and whether standard or wide vertically oriented FTA Mounting Channels are installed. Horizontally oriented FTA Mounting Channels are installed when Galvanically Isolated FTAs are mounted in the cabinet. See Section 7 or 8 for a detailed description of the cabinets and the FTA Mounting Channels.

Vertical FTA Mounting Channels Vertical FTA Mounting Channels are available in two sizes, standard and wide, to better accommodate the amount of process control wiring that connects to the FTAs. The FTA Mounting Channels provide both a mounting surface for the FTAs and dual channels (troughs) to route the FTA to IOP cabling, and the process control wiring. The FTA to IOP or Power Distribution Assembly cabling is routed in the right channel, and the process control wiring is routed in the left channel.

Continued on next page

4.1 Overview, Continued

Horizontal FTA Mounting Channels

Horizontal FTA Mounting Channels are installed when Galvanically Isolated FTAs are mounted in the cabinet. Only Galvanically Isolated FTAs are to be mounted on the horizontal FTA Mounting Channels. They are approximately 61 centimeters (24 inches) long and up to eight horizontal FTA Mounting Channels can be accommodated on one side of the cabinet.

The FTA to IOP, Power Distribution Assembly, or Marshalling Panel cabling is routed in the upper channel to the left side of the cabinet, and the process control wiring is routed in the lower channel to the right side of the cabinet.

4.2 FTA Selection

Overview

The FTA has circuits that convert the process control signals to voltage and current levels that can be accommodated by the Process Manager or Advanced Process Manager electronics. There are a number of FTA types, with each type designed for a specific type of signal.

Rules

Rules for selecting the appropriate FTAs, installing, configuring, and the connections to the associated IOP and the process control signals, are discussed in detail in the *Process Manager I/O Installation* manual.

Continued on next page

4.2 FTA Selection, Continued

FTA sizes

The assembly layouts of three physical sizes of FTAs are illustrated in Figure 4-1.

Figure 4-1 Field Termination Assembly (FTA) Sizes

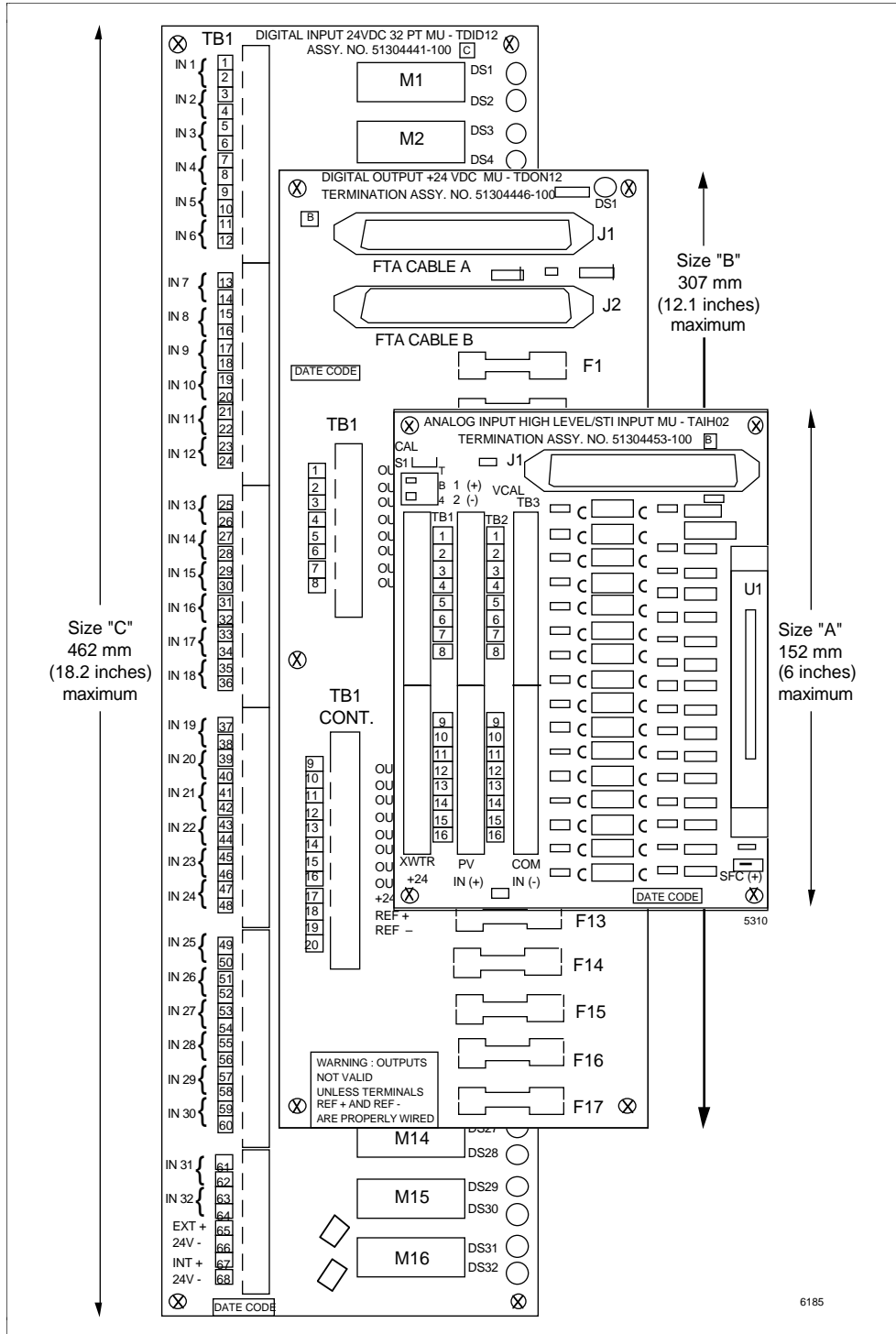

Continued on next page

4.2 FTA Selection, Continued

FTA sizes, continued

As a function of the type and number of process control signals the FTA interfaces, FTAs are produced in three different sizes, size A, B, and C. The size dimensions are shown in Figure 4-2.

Figure 4-2 Field Termination Assembly (FTA) Mounting Dimensions

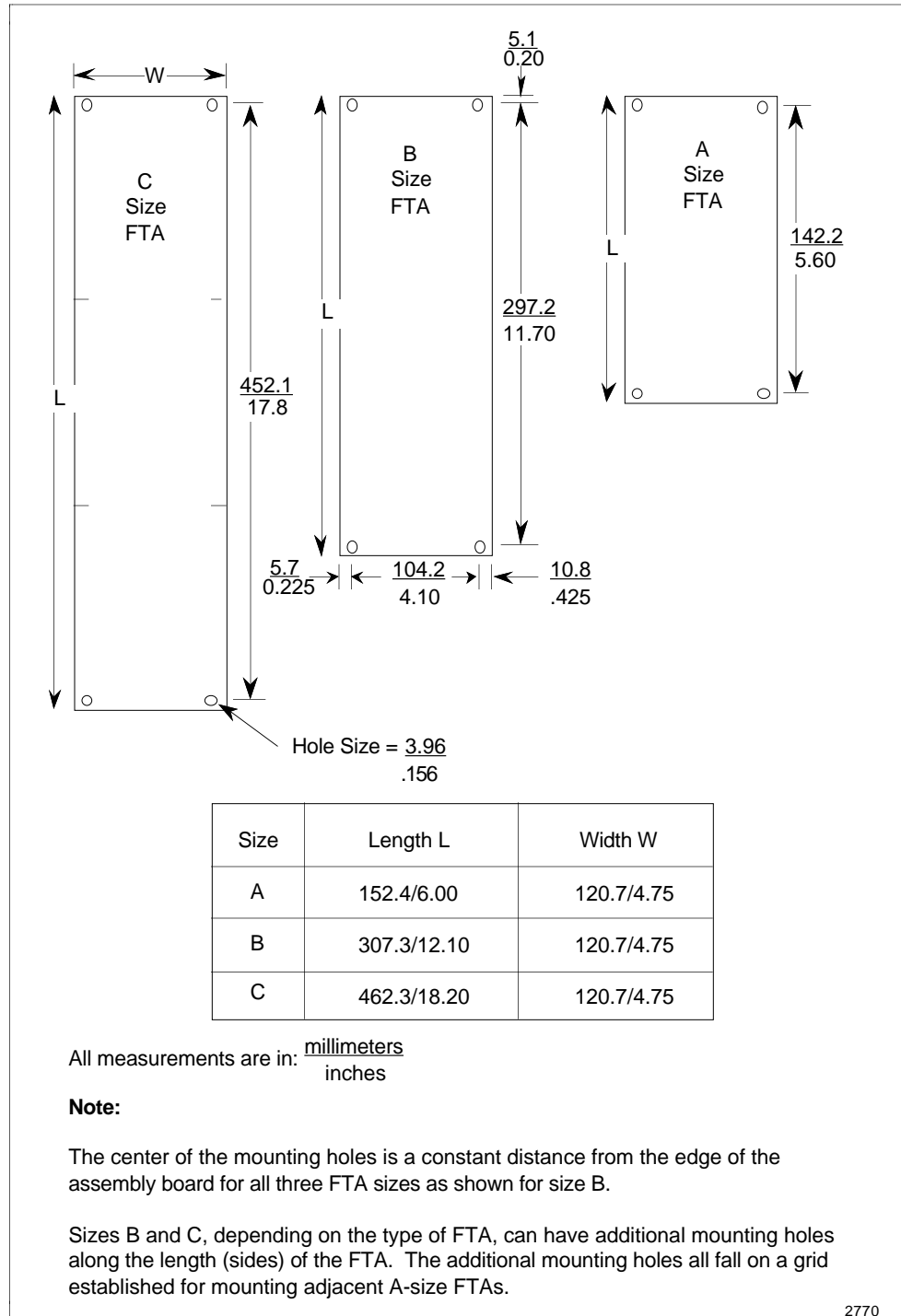

Continued on next page

4.2 FTA Selection, Continued

FTA types

Because of FTA size differences, the number of FTAs that can be installed in a cabinet will vary. Tables 4-1 and 4-2 are lists of FTAs and support assemblies by model number. When appropriate, the FTA's or supporting assembly's field terminal connector-type, number of input or output signal channels, and mounting size are listed.

Standard FTAs

For standard FTAs, the terminal connector-types are compression (C), nonremovable screw (S), and removable screw (RS).

Table 4-1 Standard FTAs and Associated Assemblies

Model Number	Description	Terminal Type	Channels	Mounting Size
MU-TAIL02	Low Level Analog Input (Single IOP)	C	8	B
MU-TAMR02	Low Level Analog Input Multiplexer—RTD (Single IOP)	C	16	B
MU-TAMR03	Low Level Analog Input Multiplexer—RTD (Single IOP)	C	16	B
MU-TAMT02	Low Level Analog Input Multiplexer—TC—Local CJR (Single IOP)	C	16	B
MU-TAMT03	Low Level Analog Input Multiplexer—TC—Local CJR (Single IOP)	C	16	B
MU-TAMT12	Low Level Analog Input Multiplexer—TC—Remote CJR (Single IOP)	C	16	B
MU-TAMT13	Low Level Analog Input Multiplexer—TC—Remote CJR (Single IOP)	C	16	B
MU-TAIH02	High Level Analog Input/STI (Single IOP)	C	16	A
MU-TAIH03	High Level Analog Input (Single IOP)	C	16	A
MU-TAIH12	High Level Analog Input/STI	C	16	B
MU-TAIH13	High Level Analog Input	C	16	B
MU-TAIH22	Enhanced Power High Level Analog/STI Input	C	16	B
MU-TAIH23	Enhanced Power High Level Analog Input	C	16	B
MU-TAIH52	High Level Analog Input/STI	S	16	B
MU-TAIH53	High Level Analog Input	S	16	B
MU-TAIH62	Enhanced Power High Level Analog Input/STI	S	16	B
MU-TSTX03	Smart Transmitter Interface (Single IOP)	C	16	A
MU-TSTX13	Smart Transmitter Interface	C	16	B
MU-TSTX53	Smart Transmitter Interface	S	16	B

Continued on next page

4.2 FTA Selection, Continued

Standard FTAs, continued

Table 4-1 Standard FTAs and Associated Assemblies, Continued

Model Number	Description	Terminal Type	Channels	Mounting Size
MU-TAOX02	Analog Output (Single IOP)	C	8	A
MU-TAOX12	Analog Output	C	8	B
MU-TAOX52	Analog Output	S	8	B
MU-TAOY22	Analog Output with Standby Manual Connector	C	16	B
MU-TAOY23	Analog Output without Standby Manual Connector	C	16	B
MU-TAOY52	Analog Output with Standby Manual Connector	S	16	B
MU-TAOY53	Analog Output without Standby Manual Connector	S	16	B
MU-TDID12	24 Vdc Digital Input	C	32	C
MU-TDID52	24 Vdc Digital Input	S	32	C
MU-TDID72	24 Vdc Digital Input (Single IOP)	RS	32	C
MU-TDIY22	24 Vdc Digital Input	C	32	C
MU-TDIY62	24 Vdc Digital Input	S	32	C
MU-TDIA12	120 Vac Digital Input	C	32	C
MU-TDIA52	120 Vac Digital Input	S	32	C
MU-TDIA72	120 Vac Digital Input (Single IOP)	RS	32	C
MU-TDIA22	240 Vac Digital Input	C	32	C
MU-TDIA62	240 Vac Digital Input	S	32	C
MU-TDON12	24 Vdc Nonisolated Digital Output	C	16	B
MU-TDON52	24 Vdc Nonisolated Digital Output	S	16	B
MU-TDOY22	24 Vdc Isolated Digital Output	C	32	B
MU-TDOY62	24 Vdc Isolated Digital Output	S	32	B
MU-TDOD12	3-30 Vdc Solid-State Digital Output	C	16	B
MU-TDOD13	3-30 Vdc Solid-State Digital Output	C	16	B
MU-TDOD14	3-30 Vdc Solid-State Digital Output	C	16	B
MU-TDOD52	3-30 Vdc Solid-State Digital Output	S	16	B

Continued on next page

4.2 FTA Selection, Continued

Standard FTAs, continued

Table 4-1 Standard FTAs and Associated Assemblies, Continued

Model Number	Description	Terminal Type	Channels	Mounting Size
MU-TDOD53	3-30 Vdc Solid-State Digital Output	S	16	B
MU-TDOD54	3-30 Vdc Solid-State Digital Output	S	16	B
MU-TDOD22	31-200 Vdc Solid-State Digital Output	C	16	B
MU-TDOD23	31-200 Vdc Solid-State Digital Output	C	16	B
MU-TDOD62	31-200 Vdc Solid-State Digital Output	S	16	B
MU-TDOD63	31-200 Vdc Solid-State Digital Output	S	16	B
MU-TDOA12	120/240 Vac Solid-State Digital Output	C	16	B
MU-TDOA13	120/240 Vac Solid-State Digital Output	C	16	B
MU-TDOA52	120/240 Vac Solid-State Digital Output	S	16	B
MU-TDOA53	120/240 Vac Solid-State Digital Output	S	16	B
MU-TDOR12	120 Vac/125 Vdc Relay Digital Output	C	16	B
MU-TDOR52	120 Vac/125 Vdc Relay Digital Output	S	16	B
MU-TDOR22	240 Vac/125 Vdc Relay Digital Output	C	16	B
MU-TDOR62	240 Vac/125 Vdc Relay Digital Output	S	16	B
MU-TDOY23	240 Vac/125 Vdc Relay Digital Output	C	16	B
MU-TDOY63	240 Vac/125 Vdc Relay Digital Output	S	16	B
MU-TPIX12	Pulse Input	C	8	B
MU-TPIX52	Pulse Input	S	8	B
MU-TSDT02	Serial Device Interface—Toledo Weigh Cell	DB-25	1	A
MU-TSDM02	Serial Device Interface—Manual/Auto Station	C	1	A
MU-TSDU02	Serial Device Interface—UDC 6000 Modbus	C	1	A
MU-TSIA12	Serial Interface—Allen-Bradley	DB-25	1	A
MU-TSIM12	Serial Interface—Modbus RTU	C/DB-25	1	A
MU-TDPR01	Digital Input Power Distribution Assembly —16 outputs	S	N/A	A
MU-TDPR02	Digital Input Power Distribution Assembly—12 outputs	S	N/A	A
MU-TLPA02	Power Adapter (supports LLAI Mux, SDI, and SI)	C	2	A

Continued on next page

4.2 FTA Selection, Continued

Galvanically Isolated FTAs

For Galvanically Isolated FTAs, the terminal connector-types are compression (C) and crimp pin (CP). The Marshalling Panel has nonremovable screw (S) terminals.

Table 4-2 Galvanically Isolated FTAs and Associated Assemblies

Model Number	Description	Terminal Type	Channels	Mounting Size
MU-GAIH12	High Level Analog Input	C	16	B
MU-GAIH82	High Level Analog Input	CP	16	B
MU-GAIH13	High Level Analog Input/Smart Transmitter Interface	C	16	B
MU-GAIH83	High Level Analog Input/Smart Transmitter Interface	CP	16	B
MU-GAIH14	High Level Analog Input/Smart Transmitter Interface (High drive)	C	16	B
MU-GAIH84	High Level Analog Input/Smart Transmitter Interface (High drive)	CP	16	B
MU-GAIH22	High Level Analog Input (Auxiliary receiver output)	C	16	B
MU-GAIH92	High Level Analog Input (Auxiliary receiver output)	CP	16	B
MU-GAOX02	Analog Output (Single IOP)	C	8	B
MU-GAOX72	Analog Output (Single IOP)	CP	8	B
MU-GAOX12	Analog Output	C	8	B
MU-GAOX82	Analog Output	CP	8	B
MU-GDID12	24 Vdc Digital Input (Contact output to IOP)	C	32	B
MU-GDID82	24 Vdc Digital Input (Contact output to IOP)	CP	32	B
MU-GDID13	24 Vdc Digital Input (Solid-state output to IOP)	C	32	B
MU-GDID83	24 Vdc Digital Input (Solid-state output to IOP)	CP	32	B
MU-GDOD12	24 Vdc Digital Output (Contact output to IOP)	C	16	B
MU-GDOD82	24 Vdc Digital Output (Contact output to IOP)	CP	16	B
MU-GDOL12	24 Vdc Digital Input (Line Fault Detection)	C	16	B
MU-GDOL82	24 Vdc Digital Input (Line Fault Detection)	CP	16	B
MU-GLFD02	Combiner Panel	N/A	N/A	A
MU-GPRD02	Galvanic Isolation Power Distribution Assembly	N/A	N/A	A
MU-GMAR52	Marshalling Panel	S	N/A	B

4.3 Cabinet Entry

Cabinet Access

The process control signal cables enter the Process Manager or Advanced Process Manager cabinet through either the top or bottom.

Bottom entry

For bottom entry, the cabinet floor has sliding plates that are retained by cage nuts or allen screws. The plates can be adjusted to vary the size of the entry slots.

Top entry

When top entry is desired, the top panel must be removed by extracting the cabinet lifting eye-bolts and then punching entry holes in the panel as needed.

CAUTION

CAUTION—Do not attempt to punch holes in the panel while it is still mounted on the cabinet. This may cause metal debris from the panel to drop down onto the cabinet equipment and result in electrical damage when power is applied to the equipment.

Cable clamping

For either top or bottom entry, the cables should be clamped firmly to the inside of the cabinet. The clamping should be able to withstand approximately a 45 kg (100 pound) pull. The cabinet is special because it includes a cable clamp rail at the bottom. The rail can be remounted at the top if required.

Reference

See Section 7 or 8 for a illustration that shows the floor FTA cable entry points for the type of cabinet installed.

4.4 Signal Tray Wiring Compatibility

Wiring rules

The process wiring to the Process Manager or Advanced Process Manager should be segregated by signal level in different trays or conduits to minimize cross talk. The segregation rules are as follows.

- Millivolt signals from electrical components, such as thermocouples, low voltage dc signals, 1-5 V/4-20 mA, and digital/contact circuits with voltages less than 30 Vac peak/DC, should be in individual cables that provide a protective shield. They can all be routed in the same cable tray. The tray can also include UCN coaxial cables, Master Reference Ground cables (Safety Ground cables in a CE Compliant installation) cables, and 50-conductor FTA to IOP cables.
- Circuits running at higher voltages, or nonshielded circuits at any voltage, belong in their own metal tray compartment or conduit. Thermocouple signals with a common mode of over 30 Vdc are also in this latter category.
- Wiring to Galvanically Isolated FTAs must be separated from all other wiring.

Additional information can be found in the *Process Manager/Advanced Process Manager Installation*, *Process Manager I/O Installation*, and the *TDC-3000^X System Site Planning* manuals.

4.5 Process Wiring Termination

Compression terminals	All standard types of FTAs are available with compression-type terminal connectors that mate with the FTA's connectors. To connect to an FTA with compression-type terminal connectors, the wire insulation is striped for 7.5 millimeters (3/8 inch), plus or minus 3 millimeters (1/8 inch), inserted into the connector terminal, and then held by tightening the individual terminal screw. The connector accepts 0.3 through 2.5 mm ² (14 through 22 AWG) stranded wire. It also accepts two 1 mm ² (18 AWG) stranded wires, or a single 3.5 mm ² (12 AWG) solid wire. Figure 2-11 is an illustration of a typical compression-type terminal connector.
Screw terminals	Some standard FTAs are available with screw-type terminal connectors that require the installation of a wire lug at the end of the wire. Refer to Figure 2-12 for an illustration of a typical fixed screw-type terminal connector and Figure 2-13 for an illustration of a typical removable screw-type terminal connector.
Pluggable connectors	The Galvanically Isolated FTAs do not have field terminal connectors mounted directly on the assembly's printed circuit board as the non-Intrinsically Safe FTAs do, instead field wires are connected to compression-type or crimp pin-type pluggable connectors that mate with the connector on the individual Galvanic Isolation Module. The compression-type connectors accommodate size 0.3 to 3.5 mm ² (12 to 22 AWG) wiring, while the crimp pin-type terminal connectors accommodate size 0.5 to 2.5 mm ² (14 to 20 AWG) wiring. Figures 2-14 and 2-15 are illustrations of the crimp pin-type and screw-type pluggable terminal connectors, respectively.
FTA signal requirements	The wiring schematics, terminal connections, and other details for wiring each type of FTA are discussed in detail in the <i>Process Manager I/O Installation</i> manual. Refer to this manual for special installation requirements for some FTAs, such as the Low Level Analog Input Multiplexer, Serial Device Interface, and Serial Interface FTAs.

Section 5 – Hazardous Environment Planning

5.1 Overview

Section contents The topics covered in this section are:

	Topic	See Page
5.1	Overview.....	79
5.2	Hazardous Area Classifications	80
5.3	PM and APM Hazardous Area Requirements.....	82
5.4	Division 2 (Zone 2) Wiring.....	83
5.5	Process Control Wiring Current Limiting	101

Introduction

Certain processes handle ignitable or explosive materials. Local electrical codes require that electrical devices that are located in, or connected to, such process areas have some type of control to prevent accidental ignition of the process material. Terminology used to discuss these installations is defined in this section, followed by specific requirements for the Process Manager (PM) or Advanced Process Manager (APM). For information about intrinsic safety applications, see your Honeywell Sales Engineer.

5.2 Hazardous Area Classifications

Electrical codes

Hazardous materials are classified by a variety of terms. The terminology for two commonly used electrical codes is summarized in Table 5-1. These are the National Electrical Code (NEC) in the USA, and the International Electrotechnical Commission (IEC) standards, headquartered in Switzerland. The table is not complete. Check your own local electrical codes for addition information and definition.

Table 5-1 Hazardous Area Classifications

NEC	IEC	Environment
Class I		Explosive gases or vapors are present.
Class II		Combustible dusts are present.
Class III		Ignitable fibers or flyings are present.
Division 1	Zone 0	A location where a hazardous concentration of gases or vapors exists approximately 10-100% of the time (subject to interpretation as above).
Division 1	Zone 1	A location where a hazardous concentration of gases or vapors exists approximately 1-10% of the time (subject to interpretation as above).
Division 2	Zone 2	A location where a hazardous concentration of gases or vapors exists approximately 0.1-1% of the time (subject to interpretation as above).
Nonhazardous	Nonhazardous	Hazardous vapors exist less than 0.1% of the time.
Group A	Group IIC	A hazardous atmosphere containing acetylene or other similar gases or vapors.
Group B	Group IIC	A hazardous atmosphere containing hydrogen or other similar gases or vapors.
Group C	Group IIB	A hazardous atmosphere containing ethylene or other similar gases or vapors.
Group D	Group IIA	A hazardous atmosphere containing pentane or other similar gases or vapors.
Group E		A hazardous atmosphere containing metal dust, such as aluminum.
Group F		A hazardous atmosphere containing carbon black, coal, or coke dust.

Continued on next page

5.2 Hazardous Area Classifications, Continued

Code interpretation

In Table 5-1, the divisions (zones) are shown to be subject to interpretation. For example, an area that has a hazardous atmosphere for 1 hour in 10,000 hours (0.01% of the time) is far off the chart for hazardous areas. As such, it seems to be a safe and nonhazardous place to locate electronic equipment; however, when the equipment has a hot component that is capable of causing ignition 100% of the time, explosion is imminent during any process emission. This is a poor environment in which to install nonapproved (for hazardous areas) electronics. It should be classified as Division 2 (Zone 2) acceptable, regardless of Table 5-1.

Hazardous area planning

Referencing Table 5-1, the approach to use when planning the installation of a Process Manager or Advanced Process Manager depends on whether the process is classified as hazardous or nonhazardous and the designated class, group, and division of the electrical installation and material handling areas. The area in which the Process Manager or Advanced Process Manager is installed is not necessarily in the same category as the material-handling area of the process. For example, in using this table, oil refiners use materials that are defined by the NEC as being hazardous and belong to Class 1, Groups B, C, and D. The installation has to be appropriately planned.

5.3 PM and APM Hazardous Area Requirements

Factory Mutual approval Many Process Manager or Advanced Process Manager subsystem configurations are approved by Factory Mutual for mounting in Class 1, Division 2 locations. Table 5-2 is a list of the approved components. When a cabinet configuration is approved, a label is attached to the cabinet containing the approved components specified in the initial purchase order. Certain components, such as an FTA containing exposed relay contacts, are not approved for these applications because the relay contacts may produce sparks.

PM or APM placement considerations The considerations for Process Manager or Advanced Process Manager placement are

- Use only those Process Manager or Advanced Process Manager components that have been certified for safe use in Division 2 locations.
- Locate the Process Manager or Advanced Process Manager in a nonhazardous area, or
- Purge the Process Manager or Advanced Process Manager enclosure or the Process Manager or Advanced Process Manager area of gasses or vapors.

PM or APM placement publications In the USA, the Division 2 or nonhazardous area for placing Process Manager or Advanced Process Manager enclosures can be selected by using publications such as the National Fire Protection Agency (NFPA) publication #497, *Classification of Class I Hazardous Locations for Electrical Installations in Chemical Plants*. Should no Division 2 or nonhazardous area exist, purged/pressurized enclosures or buildings are needed. Suitable purge techniques are described in local electrical code documents such as NFPA #496, *Purged and Pressurized Enclosures for Electrical Equipment* National Fire Protection Agency

5.4 Division 2 (Zone 2) Wiring

Electrical code approval For certain electrical codes, the Process Manager or Advanced Process Manager can connect directly to devices located in Division 2 (Zone 2) areas, and the wiring techniques and materials can be those approved for use in ordinary (nonhazardous) locations. Refer to the *Process Manager I/O Installation* manual for connection diagrams.

Nonincendive wiring Use of IOP and field wiring to the FTAs that are identified by an asterisk (*) in Table 5-2 has been approved as nonincendive wiring by Factory Mutual. For example, when the wiring is opened, shorted, or grounded, and the Process Manager or Advanced Process Manager is operating normally, the wiring will not release enough energy to cause ignition in a flammable atmosphere.

In some jurisdictions, this wiring need not conform to normal Division 2 wiring rules, but can be any wiring suitable for ordinary locations.

Division 2 wiring rules Wiring to all FTAs must conform to the Division 2 wiring rules, except that when digital output circuits have been current and voltage limited to nonincendiary levels by the customer, these circuits may also be nonincendiary. See ANSI/ISA S12.12, the section “Electrical Equipment For Use In Class I, Division 2 Hazardous [Classified] Locations.”

Continued on next page

5.4 Division 2 (Zone 2) Wiring, Continued

Approved Division 2 area equipment

Table 5-2 lists the Process Manager and Advanced Process Manager equipment that have been approved for operation in Division 2 areas.

Table 5-2 PM and APM Equipment Approved for Use in Division 2 Areas

Model Number	Non CE Compliant Part Number	CE Compliant Part Number	Description
IOPs			
MU-PAIL02	N/A	51304481-100	Low level Analog Input (LLAI)
MU-PLAM02	N/A	51304362-100	Low Level Multiplexer Analog Input (LLMux)
MU-PAIH02	N/A	51304489-100	High Level Analog Input (HLAI)
MU-PAIH03	N/A	51304754-100	High Level Analog Input (HLAI)
MU-PSTX03	N/A	51304516-200	Smart Transmitter Interface (STIM)
MU-PAOX03	51304672-100	51304672-125	Analog Output (AO)
MU-PAOY22	N/A	80363969-100	Analog Output (AO)
MU-PDIS11	N/A	51304690-100	Digital Input Sequence of Events (DI)
MU-PDIX02	N/A	51304485-100	Digital Input (DI)
MU-PDIY22	N/A	80363972-100	Digital Input (DI)
MU-PDOX02	N/A	51304487-100	Digital Output (DO)
MU-PDOY22	N/A	80363975-100	Digital Output (DO)
MU-PPIX02	N/A	51304386-100	Pulse Input (PI)
MU-PSDX02	N/A	51304362-200	Serial Device Interface (SDI)
MU-PSIM11	N/A	51304362-300	Serial Interface (SI)

Continued on next page

5.4 Division 2 (Zone 2) Wiring, Continued

Approved Division 2
area equipment,
continued

Table 5-2 PM and APM Equipment Approved for Use in Division 2 Areas, Continued

Model Number	Non CE Compliant Part Number	CE Compliant Part Number	Description
Standard FTA Components			
* MU-TAIL02	51304437-100	N/A	Low Level Analog Input with compression terminals
* MU-TAMR02	51304477-100	N/A	LLMux Analog Input RTD with compression terminals
* MU-TAMR03	N/A	51309218-125	LLMux Analog Input RTD with compression terminals
* MU-TAMT02	51401491-100	N/A	LLMux Analog Input TC with compression terminals
* MU-TAMT03	N/A	51409223-125	LLMux Analog Input TC with compression terminals
* MU-TAMT12	51401573-100	N/A	LLMux Analog Input TC with remote CJR, comp term
* MU-TAMT13	N/A	51409213-125	LLMux Analog Input TC with remote CJR, comp term
* MU-TAIH02	51304453-100	N/A	High Level Analog Input/STI with compression term
* MU-TAIH03	N/A	51309136-125	High Level Analog Input/STI with compression term
* MU-TAIH12	51304337-100	N/A	High Level Analog Input/STI with compression term
* MU-TAIH13	N/A	51309138-125	High Level Analog Input/STI with compression term
* MU-TAIH22	80366195-100	N/A	High Level Analog Input with compression term
* MU-TAIH23	N/A	80366195-125	High Level Analog Input with compression term
* MU-TAIH52	51304337-200	N/A	High Level Analog Input/STI with screw terminals
* MU-TAIH53	N/A	51309138-225	High Level Analog Input/STI with screw terminals
* MU-TAIH62	80366192-100	N/A	High Level Analog Input/STI with screw terminals
* MU-TSTX03	N/A	51304140-125	Smart Transmitter Interface with compression term
* MU-TSTX13	N/A	51304142-125	Smart Transmitter Interface with compression term
* MU-TSTX53	N/A	51304142-225	Smart Transmitter Interface with screw terminals
* MU-TAOX02	51304476-100	51304476-125	Analog Output with compression terminals
* MU-TAOX12	51304335-100	51304335-125	Analog Output with compression terminals
* MU-TAOX52	51304335-200	51304335-225	Analog Output with screw terminals
* MU-TAOY22	80366177-100	80366177-125	Analog Output with comp term, with Standby Manual
* MU-TAOY23	80366177-200	80366177-225	Analog Output with comp term, w/o Standby Manual

Continued on next page

5.4 Division 2 (Zone 2) Wiring, Continued

Approved Division 2
area equipment,
continued

Table 5-2 PM and APM Equipment Approved for Use in Division 2 Areas, Continued

Model Number	Non CE Compliant Part Number	CE Compliant Part Number	Description
Standard FTA Components, continued			
* MU-TAOY52	80364007-100	80364007-125	Analog Output with screw term, with Standby Manual
* MU-TAOY53	80364007-200	80364007-225	Analog Output with screw term, w/o Standby Manual
* MU-TDID12	51304441-100	51304441-125	24 Vdc Digital Input with compression terminals
* MU-TDID52	51304441-200	51304441-225	24 Vdc Digital Input with fixed-screw terminals
* MU-TDID72	51303928-100	N/A	24 Vdc Digital Input with removable-screw terminals
* MU-TDIY22	80366180-100	80366180-125	24 Vdc Digital Input with compression terminals
* MU-TDIY62	80364010-100	80364010-125	24 Vdc Digital Input with screw terminals
MU-TDPR02	51304425-100	51304425-125	Digital Input Power Distribution Assembly
MU-TDIA12	51304439-100	51304439-125	120 Vac Digital Input with compression terminals
MU-TDIA52	51304439-200	51304439-225	120 Vac Digital Input with fixed screw terminals
MU-TDIA72	51303930-100	N/A	120 Vac Digital Input with removable screw terminals
MU-TDIA22	51304431-100	51304431-125	240 Vac Digital Input with compression terminals
MU-TDIA62	51304431-200	51304431-225	240 Vac Digital Input with fixed screw terminals
* MU-TDON12	51304446-100	N/A	24 Vdc Nonisolated Digital Output with comp term
* MU-TDON52	51304446-200	N/A	24 Vdc Nonisolated Digital Output with screw term
* MU-TDOY22	80366183-100	80366183-125	24 Vdc Isolated Digital Output with comp term
* MU-TDOY62	80364013-100	80364013-125	24 Vdc Isolated Digital Output with screw term
* MU-TDOD12	51304423-100	N/A	3-30 Vdc Digital Output with compression terminals
* MU-TDOD13	51304650-100	N/A	3-30 Vdc Digital Output with compression terminals
* MU-TDOD14	N/A	51309153-125	3-30 Vdc Digital Output with compression terminals
* MU-TDOD52	51304423-200	N/A	3-30 Vdc Digital Output with screw terminals
* MU-TDOD53	51304650-200	N/A	3-30 Vdc Digital Output with screw terminals
* MU-TDOD54	N/A	51309153-225	3-30 Vdc Digital Output with screw terminals

Continued on next page

5.4 Division 2 (Zone 2) Wiring, *Continued*

Approved Division 2
area equipment,
continued

Table 5-2 PM and APM Equipment Approved for Use in Division 2 Areas, *Continued*

Model Number	Non CE Compliant Part Number	CE Compliant Part Number	Description
Standard FTA Components, continued			
MU-TDOD22	51304428-100	N/A	31-200 Vdc Digital Output with compression terminals
MU-TDOD62	51304428-200	N/A	31-200 Vdc Digital Output with fixed-screw terminals
MU-TDOD23	N/A	51309154-125	5-200 Vdc Digital Output with compression terminals
MU-TDOD63	N/A	51309154-225	5-200 Vdc Digital Output with screw terminals
MU-TDOA12	51304408-100	N/A	120/240 Vac Solid-State Digital Output w/comp term
MU-TDOA13	51304648-100	51304648-125	120/240 Vac Solid-State Digital Output w/comp term
MU-TDOA52	51304408-200	N/A	120/240 Vac Solid-State Digital Output w/screw term
MU-TDOA53	51304648-200	51304648-225	120/240 Vac Solid-State Digital Output w/screw term
* MU-TPIX12	51304084-100	51304084-125	Pulse Input with compression terminals
* MU-TPIX52	51304084-200	51304084-225	Pulse Input with screw terminals
MU-TSDM02	51303932-202	N/A	Serial Device Interface—Manual/Auto Station
MU-TSDT02	51303932-201	N/A	Serial Device Interface—Toledo Weigh Cell
MU-TSDU02	51303932-203	N/A	Serial Device Interface—UDC 6000
MU-TSIM12	51303932-401	51303932-426	Serial Interface—Modbus EIA-232
MU-TSIM22	51303932-403	51303932-428	Serial Interface—Modbus EIA-422/485
MU-TLPA02	51304467-100	51304467-125	Power Adapter

Continued on next page

5.4 Division 2 (Zone 2) Wiring, Continued

Approved Division 2
area equipment,
continued

Table 5-2 PM and APM Equipment Approved for Use in Division 2 Areas, Continued

Model Number	Non CE Compliant Part Number	CE Compliant Part Number	Description
Galvanically Isolated FTA Components			
* MU-GAIH12	51304636-100	N/A	High Level Analog Input with compression terminals
* MU-GAIH13	51304718-100	51304718-125	HLAI/STI with compression terminals
* MU-GAIH14	51304730-100	51304730-125	HLAI/STI with compression terminals
* MU-GAIH22	51304748-100	51304748-125	High Level Analog Input with compression terminals
* MU-GAIH82	51304636-300	N/A	High Level Analog Input with crimp terminals
* MU-GAIH83	51304718-300	51304718-325	HLAI/STI with crimp terminals
* MU-GAIH84	51304730-300	51304730-325	HLAI/STI with crimp terminals
* MU-GAIH92	51304748-300	51304748-325	High Level Analog Input with crimp terminals
* MU-GAOX02	51304638-100	51304638-125	Analog Output with comp term
* MU-GAOX12	51304638-500	51304638-525	Analog Output with comp term
* MU-GAOX72	51304638-300	51304638-325	Analog Output with crimp term
* MU-GAOX82	51304638-700	51304638-725	Analog Output with crimp terminals
* MU-GDID12	51304640-100	51304640-125	Digital Input with compression terminals
* MU-GDID13	51304728-100	51304728-125	Digital Input with compression terminals
* MU-GDID82	51304640-300	51304640-325	Digital Input with crimp terminals
* MU-GDID83	51304728-300	51304728-325	Digital Input with crimp terminals
* MU-GDOD12	51304642-100	51304642-125	24 Vdc Digital Output with compression terminals
* MU-GDOD82	51304642-300	51304642-325	24 Vdc Digital Output with crimp terminals
* MU-GDOL12	51304736-100	51304736-125	24 Vdc Digital Output with compression terminals
* MU-GDOL82	51304736-300	51304736-325	24 Vdc Digital Output with crimp terminals
MU-GLFD02	51304632-100	51304632-125	Combiner Panel
MU-GMAR52	51304646-100	51309156-125	Marshalling Panel
MU-GPRD02	51304644-100	51304644-125	Power Distribution Assembly

Continued on next page

5.4 Division 2 (Zone 2) Wiring, Continued

Approved Division 2
area equipment,
continued

Table 5-2 PM and APM Equipment Approved for Use in Division 2 Areas, Continued

Model Number	Non CE Compliant Part Number	CE Compliant Part Number	Description
I/O Link Extender			
MU-IOLM02			Standard I/O Link Extender—Local Card File
	N/A	51304419-100	Standard I/O Link Extender Card
	N/A	51201557-300	Standard I/O Link Extender Coupler
MU-IOLX02			Standard I/O Link Extender—Remote Card File
	N/A	51304419-100	Standard I/O Link Extender Card
	N/A	51201557-100	Standard I/O Link Extender Coupler
MU-ILDX03			Long Distance I/O Link Extender
	N/A	51304532-100	Long Distance I/O Link Extender Card
	N/A	51309208-100	Long Distance I/O Link Extender Coupler

Continued on next page

5.4 Division 2 (Zone 2) Wiring, Continued

Approved Division 2
area equipment,
continued

Table 5-2 PM and APM Equipment Approved for Use in Division 2 Areas, Continued

Model Number	Non CE Compliant Part Number	CE Compliant Part Number	Description
PMM Card Sets			
MU-PMMR02			Redundant PMM Card Set
	51303982-400	N/A	Control Card
	51303979-400	N/A	I/O Link Interface Card
	51303976-400	N/A	Communication Card
	51304493-100	N/A	Modem Card
	51304501-100	N/A	Redundancy Driver Card
	51201421-100	N/A	PMM Redundancy Cable
MU-PMMX02			Nonredundant PMM Card Set
	51303982-400	N/A	Control Card
	51303979-400	N/A	I/O Link Interface Card
	51303976-400	N/A	Communication Card
	51304493-100	N/A	Modem Card
	51304501-100	N/A	Redundancy Driver Card

Continued on next page

5.4 Division 2 (Zone 2) Wiring, Continued

Approved Division 2
area equipment,
continued

Table 5-2 PM and APM Equipment Approved for Use in Division 2 Areas, Continued

Model Number	Non CE Compliant Part Number	CE Compliant Part Number	Description
APMM Card Sets			
MU-APMR01			Redundant APMM Card Set
	N/A	51304518-100	Advanced Control Card
	N/A	51303979-500	Advanced I/O Link Interface Card
	N/A	51304685-100	Advanced Communication Card
	N/A	51304493-200	Modem Card
	N/A	51304190-300	Filler Card
	N/A	51201421-100	APMM Redundancy Cable
MU-APMS01			Nonredundant APMM Card Set
	N/A	51304518-100	Advanced Control Card
	N/A	51303979-500	Advanced I/O Link Interface Card
	N/A	51304685-100	Advanced Communication Card
	N/A	51304493-200	Modem Card
	N/A	51304190-300	Filler Card
Card File Assembly			
MU-PMFR02	51401548-100	N/A	Card File Assembly for 2 PMMs or APMMs and 5 IOPs
MU-PMFX02	51401547-100	N/A	Card File Assembly for 1 PMM or APMM and 10 IOPs
MU-IOFX02	51401546-100	N/A	Card File Assembly for 15 IOPs
MU-PMFR03	N/A	51404212-100	Card File Assembly for 2 PMMs or APMMs and 5 IOPs
MU-PMFX03	N/A	51404211-100	Card File Assembly for 1 PMM or APMM and 10 IOPs
MU-IOFX03	N/A	51404210-100	Card File Assembly for 15 IOPs

Continued on next page

5.4 Division 2 (Zone 2) Wiring, Continued

Approved Division 2
area equipment,
continued

Table 5-2 PM and APM Equipment Approved for Use in Division 2 Areas, Continued

Model Number	Non CE Compliant Part Number	CE Compliant Part Number	Description
Cables			
MU-KTPC00	51201396-100	N/A	FTA to IOP, DIN to DIN connector
MU-KTPC05	51201396-005	N/A	FTA to IOP, DIN to DIN connector—5 meters
MU-KTPC10	51201396-010	N/A	FTA to IOP, DIN to DIN connector—10 meters
MU-KTPC15	51201396-015	N/A	FTA to IOP, DIN to DIN connector—15 meters
MU-KTPC20	51201396-020	N/A	FTA to IOP, DIN to DIN connector—20 meters
MU-KTPC25	51201396-025	N/A	FTA to IOP, DIN to DIN connector—25 meters
MU-KTPC30	51201396-030	N/A	FTA to IOP, DIN to DIN connector—30 meters
MU-KTPC35	51201396-035	N/A	FTA to IOP, DIN to DIN connector—35 meters
MU-KTPC40	51201396-040	N/A	FTA to IOP, DIN to DIN connector—40 meters
MU-KTPC45	51201396-045	N/A	FTA to IOP, DIN to DIN connector—45 meters
MU-KTPC50	51201396-050	N/A	FTA to IOP, DIN to DIN connector—50 meters
MU-KFTA00	51201396-100	N/A	FTA to IOP, phone to phone connector
MU-KFTA05	51201396-005	N/A	FTA to IOP, phone to phone connector—5 meters
MU-KFTA10	51201396-010	N/A	FTA to IOP, phone to phone connector—10 meters
MU-KFTA15	51201396-015	N/A	FTA to IOP, phone to phone connector—15 meters
MU-KFTA20	51201396-020	N/A	FTA to IOP, phone to phone connector—20 meters
MU-KFTA25	51201396-025	N/A	FTA to IOP, phone to phone connector—25 meters
MU-KFTA30	51201396-030	N/A	FTA to IOP, phone to phone connector—30 meters
MU-KFTA35	51201396-035	N/A	FTA to IOP, phone to phone connector—35 meters
MU-KFTA40	51201396-040	N/A	FTA to IOP, phone to phone connector—40 meters
MU-KFTA45	51201396-045	N/A	FTA to IOP, phone to phone connector—45 meters
MU-KFTA50	51201396-050	N/A	FTA to IOP, phone to phone connector—50 meters

Continued on next page

5.4 Division 2 (Zone 2) Wiring, Continued

Approved Division 2
area equipment,
continued

Table 5-2 PM and APM Equipment Approved for Use in Division 2 Areas, Continued

Model Number	Non CE Compliant Part Number	CE Compliant Part Number	Description
Cables			
MU-KFTS00	N/A	51204033-100	FTA to IOP, phone to phone connector
MU-KFTS05	N/A	51204033-005	FTA to IOP, phone to phone connector—5 meters
MU-KFTS10	N/A	51204033-010	FTA to IOP, phone to phone connector—10 meters
MU-KFTS15	N/A	51204033-015	FTA to IOP, phone to phone connector—15 meters
MU-KFTS20	N/A	51204033-020	FTA to IOP, phone to phone connector—20 meters
MU-KFTS25	N/A	51204033-025	FTA to IOP, phone to phone connector—25 meters
MU-KFTS30	N/A	51204033-030	FTA to IOP, phone to phone connector—30 meters
MU-KFTS35	N/A	51204033-035	FTA to IOP, phone to phone connector—35 meters
MU-KFTS40	N/A	51204033-040	FTA to IOP, phone to phone connector—40 meters
MU-KFTS45	N/A	51204033-045	FTA to IOP, phone to phone connector—45 meters
MU-KFTS50	N/A	51204033-050	FTA to IOP, phone to phone connector—50 meters
MU-KSPR00	N/A	51204037-100	Remote Power Distribution
MU-KSPR05	N/A	51204037-005	Remote Power Distribution—5 meters
MU-KSPR10	N/A	51204037-010	Remote Power Distribution—10 meters
MU-KSPR15	N/A	51204037-015	Remote Power Distribution—15 meters
MU-KSPR20	N/A	51204037-020	Remote Power Distribution—20 meters
MU-KSPR25	N/A	51204037-025	Remote Power Distribution—25 meters
MU-KSPR30	N/A	51204037-030	Remote Power Distribution—30 meters
MU-KSPR35	N/A	51204037-035	Remote Power Distribution—35 meters
MU-KSPR40	N/A	51204037-040	Remote Power Distribution—40 meters
MU-KSPR45	N/A	51204037-045	Remote Power Distribution—45 meters
MU-KSPR50	N/A	51204037-050	Remote Power Distribution—50 meters

Continued on next page

5.4 Division 2 (Zone 2) Wiring, Continued

Approved Division 2
area equipment,
continued

Table 5-2 PM and APM Equipment Approved for Use in Division 2 Areas, Continued

Model Number	Non CE Compliant Part Number	CE Compliant Part Number	Description
Cables			
MU-KFTD00	51201396-100	N/A	FTA to IOP, DIN to phone connector
MU-KFTD05	51201396-005	N/A	FTA to IOP, DIN to phone connector—5 meters
MU-KFTD10	51201396-010	N/A	FTA to IOP, DIN to phone connector—10 meters
MU-KFTD15	51201396-015	N/A	FTA to IOP, DIN to phone connector—15 meters
MU-KFTD20	51201396-020	N/A	FTA to IOP, DIN to phone connector—20 meters
MU-KFTD25	51201396-025	N/A	FTA to IOP, DIN to phone connector—25 meters
MU-KFTD30	51201396-030	N/A	FTA to IOP, DIN to phone connector—30 meters
MU-KFTD35	51201396-035	N/A	FTA to IOP, DIN to phone connector—35 meters
MU-KFTD40	51201396-040	N/A	FTA to IOP, DIN to phone connector—40 meters
MU-KFTD45	51201396-045	N/A	FTA to IOP, DIN to phone connector—45 meters
MU-KFTD50	51201396-050	N/A	FTA to IOP, DIN to phone connector—50 meters
MU-KDPR00	51201396-100	N/A	Power Distribution
MU-KDPR05	51201396-005	N/A	Power Distribution—5 meters
MU-KDPR10	51201396-010	N/A	Power Distribution—10 meters
MU-KDPR15	51201396-015	N/A	Power Distribution—15 meters
MU-KDPR20	51201396-020	N/A	Power Distribution—20 meters
MU-KDPR25	51201396-025	N/A	Power Distribution—25 meters
MU-KDPR30	51201396-030	N/A	Power Distribution—30 meters
MU-KDPR35	51201396-035	N/A	Power Distribution—35 meters
MU-KDPR40	51201396-040	N/A	Power Distribution—40 meters
MU-KDPR45	51201396-045	N/A	Power Distribution—45 meters
MU-KDPR50	51201396-050	N/A	Power Distribution—50 meters

Continued on next page

5.4 Division 2 (Zone 2) Wiring, Continued

Approved Division 2
area equipment,
continued

Table 5-2 PM and APM Equipment Approved for Use in Division 2 Areas, Continued

Model Number	Non CE Compliant Part Number	CE Compliant Part Number	Description
Cables			
MU-KLAM00	N/A	51304465-100	LLAI Mux FTA to Power Adapter (internal to cabinet)
MU-KLX076	N/A	51190696-076	LLAI Mux FTA to Power Adapter—76 meters (external to cabinet)
MU-KLX152	N/A	51190696-152	LLAI Mux FTA to Power Adapter—152 meters (external to cabinet)
MU-KLX305	N/A	51190696-305	LLAI Mux FTA to Power Adapter—305 meters (external to cabinet)
MU-KSX030	N/A	51191673-030	SDI/SI FTA to EIA-422/485—30 meters
MU-KSX152	N/A	51191673-152	SDI/SI FTA to EIA-422/485—152 meters
MU-KSX305	N/A	51191673-305	SDI/SI FTA to EIA-422/485—305 meters
	51195479-100	N/A	I/O Link Interface—2 connectors
	51195479-200	N/A	I/O Link Interface—3 connectors
	51195479-300	N/A	I/O Link Interface—4 connectors
	51195479-400	N/A	I/O Link Interface—5 connectors
	51195479-500	N/A	I/O Link Interface—6 connectors
	N/A	51204042-100	I/O Link Interface—2 connectors
	N/A	51204042-200	I/O Link Interface—3 connectors
	N/A	51204042-300	I/O Link Interface—4 connectors
	N/A	51204042-400	I/O Link Interface—5 connectors
	N/A	51204042-500	I/O Link Interface—6 connectors
MU-KGPR00	N/A	51209620-100	Galvanic Isolation Power Distribution Cable
MU-KGPR05	N/A	51209620-195	Galvanic Isolation Power Distribution Cable—5 meters
MU-KGPR10	N/A	51209620-395	Galvanic Isolation Power Distribution Cable—10 meter

Continued on next page

5.4 Division 2 (Zone 2) Wiring, Continued

Approved Division 2
area equipment,
continued

Table 5-2 PM and APM Equipment Approved for Use in Division 2 Areas, Continued

Model Number	Non CE Compliant Part Number	CE Compliant Part Number	Description
UCN Cables			
MU-NKT002	N/A	51191599-002	UCN Trunk Cable—2.5 meters
MU-NKT005	N/A	51191599-005	UCN Trunk Cable—5 meters
MU-NKT010	N/A	51191599-010	UCN Trunk Cable—10 meters
MU-NKT020	N/A	51191599-020	UCN Trunk Cable—20 meters
MU-NKT030	N/A	51191599-030	UCN Trunk Cable—30 meters
MU-NKT050	N/A	51191599-050	UCN Trunk Cable—50 meters
MU-NKT100	N/A	51191599-100	UCN Trunk Cable—100 meters
MU-NKT200	N/A	51191599-200	UCN Trunk Cable—200 meters
MU-NKT400	N/A	51191599-400	UCN Trunk Cable—400 meters
MU-NKT600	N/A	51191599-600	UCN Trunk Cable—600 meters
MU-NKD000	N/A	51191599-100	UCN Drop Cable Set (pair)
MU-NKD002	N/A	51191599-002	UCN Drop Cable Set—2 meters (pair)
MU-NKD005	N/A	51191599-005	UCN Drop Cable Set—5 meters (pair)
MU-NKD010	N/A	51191599-010	UCN Drop Cable Set—10 meters (pair)
MU-NKD020	N/A	51191599-020	UCN Drop Cable Set—20 meters (pair)
MU-NKD030	N/A	51191599-030	UCN Drop Cable Set—30 meters (pair)
MU-NKD040	N/A	51191599-040	UCN Drop Cable Set—40 meters (pair)
MU-NKD050	N/A	51191599-050	UCN Drop Cable Set—50 meters (pair)
MU-NTAP02	N/A	51201394-100	UCN 2-Drop Tap Assembly Kit (pair)
MU-NTAP04	N/A	51201395-100	UCN 4-Drop Tap Assembly Kit (pair)
MU-NTAP08	N/A	51109485-100	UCN 8-Drop Tap Assembly Kit (pair)
MU-NKTK01	N/A	51195162-100	UCN Drop Connector Kit/RG-11
MU-NKDK01	N/A	51195161-100	UCN Drop Connector Kit/RG-6
MU-NCSK01	N/A	51195160-100	UCN Trunk Splice Kit

Continued on next page

5.4 Division 2 (Zone 2) Wiring, Continued

Approved Division 2
area equipment.
continued

Table 5-2 PM and APM Equipment Approved for Use in Division 2 Areas, Continued

Model Number	Non CE Compliant Part Number	CE Compliant Part Number	Description
Power Systems			
MU-PSSX03	N/A	51401217-400	Power System, single Power Supply Module (PSM)
MU-PSRX03	N/A	51401217-500	Power System, redundant Power Supply Modules
MU-PSRB03	N/A	51401217-600	Power System, redundant PSMs with Battery Pack
MU-PSSX04	N/A	51404174-125	Power System, single Power Supply Module
MU-PSRX04	N/A	51404174-225	Power System, redundant Power Supply Modules
MU-PSRB04	N/A	51404174-325	Power System, redundant PSMs with Battery Pack
MU-PAS121	51401140-100	N/A	AC Only Power System, single PSM, 120 Vac 16 A
MU-PAR121	51401140-200	N/A	AC Only Power System, redund PSMs, 120 Vac 16 A
MU-PAS221	51401140-300	N/A	AC Only Power System, single PSM, 220 Vac 16 A
MU-PAR221	51401140-400	N/A	AC Only Power System, redund PSMs, 220 Vac 16 A
MU-PAS111	51401140-500	N/A	AC Only Power System, single PSM, 120 Vac 8 A
MU-PAR111	51401140-600	N/A	AC Only Power System, redundant PSMs, 120 Vac 8 A
MU-PAS211	51401140-700	N/A	AC Only Power System, single PSM, 220 Vac 8 A
MU-PAR211	51401140-800	N/A	AC Only Power System, redundant PSMs, 220 Vac 8 A
Standby Manual Devices			
MU-SMAC02	N/A	51401277-200	Analog Output Standby Manual Device w/case & cable
MU-SMDC02	N/A	51304526-100	Digital Output Standby Manual Device with case
MU-SMDX02	N/A	51304527-100	Digital Output Standby Manual Device with cable
Miscellaneous			
MU-MASX02		N/A	Manual/Auto Station model PC6001U2M040A0

Continued on next page

5.4 Division 2 (Zone 2) Wiring, Continued

Approved Division 2
area equipment,
continued

Table 5-2 PM and APM Equipment Approved for Use in Division 2 Areas, Continued

Model Number	Non CE Compliant Part Number	CE Compliant Part Number	Description
Cabinet Hardware			
MU-CBDX01	N/A	51401512-100	Dual-Access Cabinet, Rittal
MU-CBSX01	N/A	51401513-100	Single-Access Cabinet, Rittal
MU-TMCN01	N/A	51401246-200	Narrow FTA Mounting Channel, Rittal
MU-TMCN02	N/A		Narrow FTA Mounting Channel with ground bar, Rittal
MU-TMCW01	N/A	51401246-100	Wide FTA Mounting Channel, Rittal
MU-TMCW02	N/A		Wide FTA Mounting Channel with ground bar, Rittal
MU-CBDM01	51401605-100	N/A	Dual-Access Cabinet, NEMA 1
MU-CBSM01	51401604-100	N/A	Single-Access Cabinet, NEMA 1
MU-TMCN11	51401529-100	N/A	Narrow FTA Mounting Channel, NEMA 1
MU-TMCN12		N/A	Narrow FTA Mounting Channel with ground bar, NEMA 1
MU-TMCW11	51401529-200	N/A	Wide FTA Mounting Channel, NEMA 1
MU-TMCW12		N/A	Wide FTA Mounting Channel with ground bar, NEMA 1
MU-TSGB01	51201568-100	N/A	FTA Shield Grounding Bar

Continued on next page

5.4 Division 2 (Zone 2) Wiring, Continued

Approved Division 2
area equipment,
continued

Table 5-2 PM and APM Equipment Approved for Use in Division 2 Areas, Continued

Model Number	Non CE Compliant Part Number	CE Compliant Part Number	Description
Cabinet Fan Assemblies			
MU-FAN501			Cabinet Fan Assembly, 240 Vac
	N/A	51304074-200	Cabinet Fan Assembly, 240 Vac
	N/A	51109516-100	Fan Assembly Cable—3 meters
MU-FAN601			Cabinet Fan Assembly, 120 Vac
	N/A	51304074-100	Cabinet Fan Assembly, 120 Vac
	N/A	51109516-100	Fan Assembly Cable—3 meters
MU-FAN511			Cabinet Fan Assembly with alarm, 240 Vac
	N/A	51303940-200	Cabinet Fan Assembly with alarm, 240 Vac
	N/A	51109516-100	Fan Assembly Cable—3 meters
MU-FAN611			Cabinet Fan Assembly with alarm, 120 Vac
	N/A	51304074-100	Cabinet Fan Assembly with alarm, 120 Vac
	N/A	51109516-100	Fan Assembly Cable—3 meters

Continued on next page

5.4 Division 2 (Zone 2) Wiring, Continued

Cable size and load parameters

To ensure that the circuits are incapable of igniting a flammable atmosphere, the size of cable and load parameters must be controlled. The maximum values are given in Table 5-3.

Table 5-3 FTA Cable and Load Parameters

Parameter	Maximum Value				
	TAIL02 TAIL03 TAMR02 TAMR03 TAMT02 TAMT03 TAMT12 TAMT13	TAIH02 TAIH03 TAIH12 TAIH13 TAIH52 TAIH53 TSTX03 TSTX13 TSTX53	TDID12 TDID52 TDID72	TAOX02 TAOX12 TAOX52	TPIX12 TPIX52
V _{OC} *—Maximum Open Circuit Voltage	9 Vdc	26 Vdc	30 Vdc	26 Vdc	26 Vdc
I _{SC} *—Maximum Short Circuit Current	0.3 mA	186 mA	152 mA	22 mA	63 mA
C _a —Maximum Allowable Connected Cable Capacitance	15 μF	0.4 μF	0.25 μF	0.4 μF	0.4 μF
L _a —Maximum Allowable Cable Inductance	1 H	2.3 mH	3 mH	130 mH	17 mH
C _n —Maximum Allowable Connected Capacitance (Cable + Load)	15 μF	0.4 μF	0.25 μF	0.4 μF	0.4 μF
L _n —Maximum Allowable Connected Inductance (Cable + Load)	1 H	150 mH	400 mH	130 mH	17 mH

* Controlled by the Process Manager and Advanced Process Manager design.

ATTENTION

ATTENTION—The data in Table 5-3 is controlled by the Honeywell drawing 51109499 and cannot be changed without the approval of Factory Mutual.

5.5 Process Control Wiring Current Limiting

Current limiting

To avoid ignition of hazardous process materials, the self-powered FTA circuits in the Process Manager or Advanced Process Manager include a certain level of current limiting in the conductors that interface the process. The limiting prevents ignition by the opening, shorting, or grounding of the process circuits. The current limiting resistors are shown in the FTA schematics in the *Process Manager I/O Installation* manual.

Current limiting resistor value

The resistor value is selected to ensure a worst-case short circuit current in the hazardous area of less than 150 mA for normal operating equipment. In NFPA publication #493, *Intrinsically Safe Apparatus for Use in Division 1 Hazardous Locations*, 150 mA from a 24 Vdc source is the ignition threshold in a resistive circuit for gases in Groups A through D. The NEC permits the use of ordinary location switches, buttons, wiring and enclosures in Division 2 areas as long as the currents and voltages are limited to these values. Division 1 processes usually require zener barriers or explosion proof conduit.

Section 6 – Corrosion Protection Planning

6.1 Overview

Section contents The topics covered in this section are:

	Topic	See Page
6.1	Overview.....	103
6.2	Model Numbers.....	106

Introduction

Corrosion is one of the leading causes of electronic printed-circuit assembly board failure in harsh environments. Conformal coating of the assembly's printed circuits and components provides an answer for the problem. Conformal coated assemblies are completely covered with a thin layer of a special plastic material that is resistant to the corrosive effects of humidity and most chemical gases.

G3 rating

All coated assemblies can withstand the effects of a G3 (harsh) rated environment. Uncoated boards are rated for mild (G1) environments. This harsh environment is defined by ANSI/ISA-S71.04-1985, "Environmental Conditions for Process Measurement and Control Systems: Airborne Contaminates."

Continued on next page

6.1 Overview, Continued

Environmental harshness levels

Table 6-1 defines the environmental harshness levels for airborne contaminants.

Table 6-1 Harsh Environment Definitions from ANSI/ISA-S71.04-1985

Severity Level		G1 (Mild)	G2 (Moderate)	G3 (Harsh)	Gx (Severe)
Copper Reactivity Level (Angstroms/month)		<300	<1000	<2000	≥2000
Contaminant Gas		Concentration (Parts/Billion)			
Group A	H ₂ S	<3	<10	<50	≥50
	SO ₂ , SO ₃	<10	<100	<300	≥300
	Cl ₂	<1	<2	<10	≥10
	NO _x	<50	<125	<1250	≥1250
Group B	HF	<1	<2	<10	≥10
	NH ₃	<500	<10,000	<25,000	≥25,000
	O ₃	<2	<25	<100	≥100

Gas concentrations

Gas concentrations are for reference only and are believed to approximate the reactivity levels assuming relative humidity is less than 50%. For each 10% increase in relative humidity above 50%, or change in relative humidity by greater than 6%/hour, the severity level can be expected to increase by one level.

Continued on next page

6.1 Overview, Continued

Conformal coating symbol

Conformal-coated assemblies can be easily identified by a distinctive symbol located on the assembly. The symbol consists of a “C” that is surrounded by a solid diamond. The diamond universally symbolizes hardness. The symbol is intended to represent the hardened protection against harsh environments that conformal coating provides. Figure 6-1 illustrates the symbol on the faceplate of an Analog Output IOP.

Figure 6-1 Conformal Coating Symbol

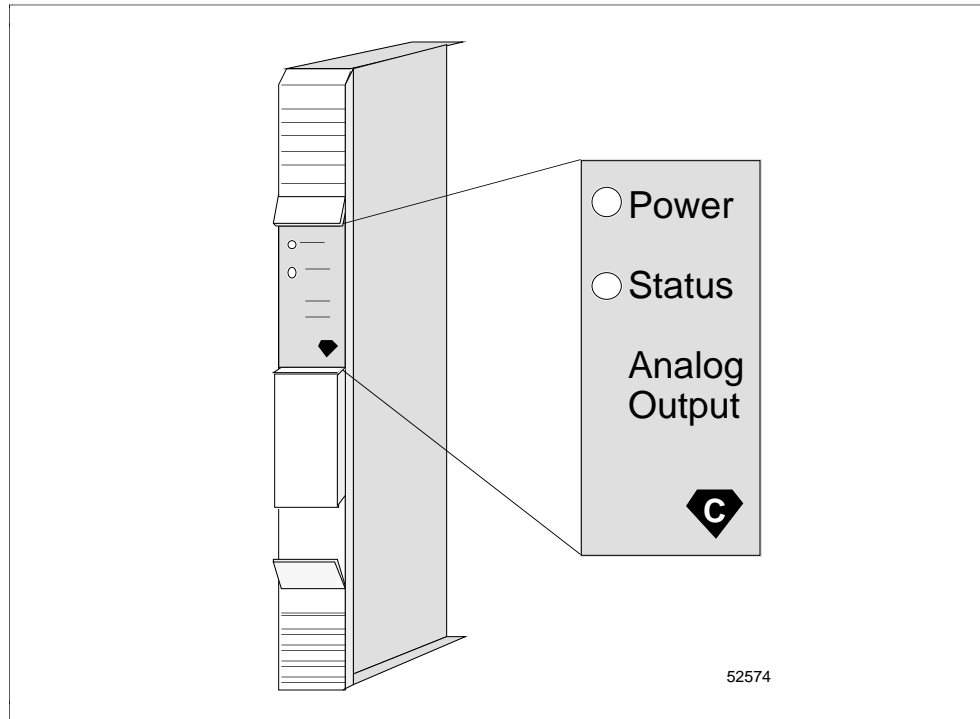

Harsh Environment Enclosure

For those users who want to locate their IOPs closer to the process and outside the control room in a severe environment, another level of protection is required. Honeywell offers the availability of a harsh environment IOP enclosure that is capable of withstanding a Gx-rated atmosphere. The product includes a sealed NEMA 4x stainless steel enclosure, a special 7-Slot card file with fans for air circulation to house conformal-coated IOP and I/O Link Extender cards, and a 24 Vdc Power System that uses components found in the PM/APM AC Only Power System. There is no active external cooling required for external ambient temperatures of up to 60°C. The IOPs interface with the PMM(s) or APMM(s) in the control room by fiber optic I/O Link Extender. Standard IOP to FTA cables that are enclosed in sealed conduit provide the IOP to associated FTA interface. The FTAs are mounted in sealed NEMA 4x stainless steel enclosures that are provided by the user.

6.2 Model Numbers

Model numbers

Model numbers for conformal-coated assemblies and upgrade kits are identified by a “MC” prefix, instead of the normal “MU” prefix for a noncoated assembly. An example would be a conformal-coated Low Level Analog Input IOP. Its model number is MC-PAIL02. The model number of the noncoated version of the IOP is MU-PAIL02.

ATTENTION

ATTENTION—The High Level Analog Input and Analog Output IOPs are available only as conformal-coated assemblies. There are no noncoated versions available. The model numbers are MC-PAIH03 and MC-PAOX03, respectively.

Assembly numbers

Typically, the part number’s tab for a conformal-coated assembly has the format “x5x” or “x7x,” where “x” can be any number, 1 through 9. This provides a standard method of identifying conformal-coated assemblies.

Continued on next page

6.2 Model Numbers, Continued

Conformal coated model list

Table 6-2 is a list of conformal-coated Process Manager and Advanced Process Manager assemblies.

Table 6-2 Conformal Coated Assembly Model Numbers

Model Number	Non CE Compliant Part Number	CE Compliant Part Number	Description
IOPs			
MC-PAIH03	N/A	51304754-150	High Level Analog Input (HLAI)
MC-PAIL02	N/A	51304481-150	Low level Analog Input (LLAI)
MC-PAOX03	51304672-125	51309152-175	Analog Output (AO)
MC-PAOY22	N/A	80363969-150	Analog Output (AO)
MC-PDIS11	N/A	51304690-150	Digital Input Sequence of Events (DI)
MC-PDIX02	N/A	51304485-150	Digital Input (DI)
MC-PDIY22	N/A	80363972-150	Digital Input (DI)
MC-PDOX02	N/A	51304487-150	Digital Output (DO)
MC-PDOY22	N/A	80363975-150	Digital Output (DO)
MC-PLAM02	N/A	51304362-150	Low Level Multiplexer Analog Input (LLMux)
MC-PPIX02	N/A	51304386-150	Pulse Input (PI)
MC-PSDX02	N/A	51304362-250	Serial Device Interface (SDI)
MC-PSIM11	N/A	51304362-350	Serial Interface (SI)
MC-PSTX02	51304516-150	N/A	Smart Transmitter Interface (STI)
MC-PSTX03	N/A	51304516-250	Smart Transmitter Interface Multivariable (STIM)
Standard FTAs			
MC-TAIL02	51304437-150	N/A	Low Level Analog Input with compression terminals
MC-TAMR02	51304477-150	N/A	LLMux Analog Input RTD with compression terminals
MC-TAMR03	N/A	51309218-175	LLMux Analog Input RTD with compression terminals
MC-TAMT02	51401491-150	N/A	LLMux Analog Input TC with compression terminals
MC-TAMT03	N/A	51301491-175	LLMux Analog Input TC with compression terminals
MC-TAMT12	51401573-150	N/A	LLMux Analog Input TC with remote CJR, comp term
MC-TAMT13	N/A	51301573-175	LLMux Analog Input TC with remote CJR, comp term

Continued on next page

6.2 Model Numbers, Continued

Conformal coated model list, continued

Table 6-2 Conformal Coated Assembly Model Numbers, Continued

Model Number	Non CE Compliant Part Number	CE Compliant Part Number	Description
Standard FTAs, continued			
MC-TAIH02	51304453-150	N/A	High Level Analog Input/STI with compression term
MC-TAIH03	N/A	51309136-175	High Level Analog Input with compression terminals
MC-TAIH12	51304337-150	N/A	High Level Analog Input/STI with compression term
MC-TAIH13	N/A	51309138-175	High Level Analog Input with compression terminals
MC-TAIH22	80366195-150	N/A	High Level Analog Input with compression terminals
MC-TAIH23	N/A	80366195-175	High Level Analog Input with compression terminals
MC-TAIH52	51304337-250	N/A	High Level Analog Input/STI with screw terminals
MC-TAIH53	N/A	51309138-275	High Level Analog Input with screw terminals
MC-TAIH62	80366192-150	N/A	High Level Analog Input/STI with screw terminals
MC-TSTX03	N/A	51309140-175	Smart Transmitter Interface with Compression Term
MC-TSTX13	N/A	51309142-175	Smart Transmitter Interface with Compression Term
MC-TSTX53	N/A	51309142-275	Smart Transmitter Interface with Screw Terminals
MC-TAOX02	51304476-150	51304476-175	Analog Output with compression terminals
MC-TAOX12	51304335-150	51304335-175	Analog Output with compression terminals
MC-TAOX52	51304335-250	51304335-275	Analog Output with screw terminals
MC-TAOY22	80366177-150	80366177-175	Analog Output with compression terminals
MC-TAOY23	80366177-250	80366177-275	Analog Output with compression terminals
MC-TAOY52	80364007-150	80364007-175	Analog Output with screw terminals
MC-TAOY53	80364007-250	80364007-275	Analog Output with screw terminals
MC-TDID12	51304441-150	51304441-175	24 Vdc Digital Input with compression terminals
MC-TDID52	51304441-250	51304441-275	24 Vdc Digital Input with fixed-screw terminals
MC-TDID72	51303928-150	N/A	24 Vdc Digital Input with removable-screw terminals
MC-TDIY22	80366180-150	80366180-175	24 Vdc Digital Input with compression terminals
MC-TDIY62	80366180-250	80366180-275	24 Vdc Digital Input with fixed-screw terminals

Continued on next page

6.2 Model Numbers, Continued

Conformal coated model list, continued

Table 6-2 Conformal Coated Assembly Model Numbers, Continued

Model Number	Non CE Compliant Part Number	CE Compliant Part Number	Description
Standard FTAs, continued			
MC-TDPR02	51304425-150	51304425-175	Digital Input Power Distribution Assembly
MC-TDIA12	51304439-150	51304439-175	120 Vac Digital Input with compression terminals
MC-TDIA52	51304439-250	51304439-275	120 Vac Digital Input with fixed-screw terminals
MC-TDIA72	51303930-150	N/A	120 Vac Digital Input with removable-screw terminals
MC-TDIA22	51304431-150	51304431-175	240 Vac Digital Input with compression terminals
MC-TDIA62	51304431-250	51304431-275	240 Vac Digital Input with fixed-screw terminals
MC-TDOA13	51304648-150	51304648-175	120/240 Vac Solid-State Digital Output w/comp term
MC-TDOA53	51304648-250	51304648-275	120/240 Vac Solid-State Digital Output w/screw term
MC-TDON12	51304446-150	N/A	24 Vdc Nonisolated Digital Output with comp term
MC-TDON52	51304446-250	N/A	24 Vdc Nonisolated Digital Output with screw term
MC-TDOY22	80366183-150	80366183-175	24 Vdc Isolated Digital Output with compression term
MC-TDOY62	80364013-150	80364013-175	24 Vdc Isolated Digital Output with screw terminals
MC-TDOD13	51304650-150	N/A	3-30 Vdc Digital Output with compression terminals
MC-TDOD14	N/A	51309153-175	3-30 Vdc Digital Output with compression terminals
MC-TDOD53	51304650-250	N/A	3-30 Vdc Digital Output with screw terminals
MC-TDOD54	N/A	51309153-275	3-30 Vdc Digital Output with screw terminals
MC-TDOD22	51304428-150	N/A	31-200 Vdc Digital Output with compression terminals
MC-TDOD23	N/A	51309154-175	31-200 Vdc Digital Output with compression terminals
MC-TDOD62	51304428-250	N/A	31-200 Vdc Digital Output with screw terminals
MC-TDOD63	N/A	51309154-275	31-200 Vdc Digital Output with screw terminals
MC-TDOR12	51304443-150	51309148-175	120 Vac/125 Vdc Relay Digital Output with comp term
MC-TDOR52	51304443-250	51309148-275	120 Vac/125 Vdc Relay Digital Output with screw term
MC-TDOR22	51304427-150	51309150-175	240 Vac/125 Vdc Relay Digital Output with comp term
MC-TDOR62	51304427-250	51309150-275	240 Vac/125 Vdc Relay Digital Output with screw term

Continued on next page

6.2 Model Numbers, Continued

Conformal coated model list, continued

Table 6-2 Conformal Coated Assembly Model Numbers, Continued

Model Number	Non CE Compliant Part Number	CE Compliant Part Number	Description
Standard FTAs, continued			
MC-TDOY23	80366189-150	80366189-175	240 Vac/125 Vdc Relay Digital Output with comp term
MC-TDOY63	80366185-150	80366185-175	240 Vac/125 Vdc Relay Digital Output with screw term
MC-TPIX12	51304084-150	51304084-175	Pulse Input with compression terminals
MC-TPIX52	51304084-250	51304084-275	Pulse Input with screw terminals
MC-TSDM02	51303932-252	N/A	Serial Device Interface—Manual/Auto Station
MC-TSDT02	51303932-251	N/A	Serial Device Interface—Toledo Weigh Cell
MC-TSDU02	51303932-253	N/A	Serial Device Interface—UDC 6000 Modbus
MC-TSIA12	51303932-453	51303932-478	Serial Interface—Allen-Bradley
MC-TSIM12	51303932-451	51303932-476	Serial Interface—Modbus EIA-232
MC-TLPA02	51304467-150	51309204-175	Power Adapter
Galvanically Isolated FTAs			
MC-GAIH12	51304636-150	N/A	High Level Analog Input with compression terminals
MC-GAIH13	51304718-150	51304718-175	High Level Analog Input/STI with compression term
MC-GAIH14	51304730-150	51304730-175	High Level Analog Input/STI with compression term
MC-GAIH22	51304748-150	51304748-175	High Level Analog Input with compression terminals
MC-GAIH82	51304636-350	N/A	High Level Analog Input with crimp terminals
MC-GAIH83	51304718-350	51304718-375	High Level Analog Input/STI with crimp terminals
MC-GAIH84	51304730-350	51304730-375	High Level Analog Input/STI with crimp terminals
MC-GAIH92	51304748-350	51304748-375	High Level Analog Input with crimp terminals
MC-GAOX02	51304638-150	51304638-175	Nonredundant Analog Output with compression term
MC-GAOX12	51304638-250	51304638-275	Redundant Analog Output with compression terminal
MC-GAOX72	51304638-350	51304638-375	Nonredundant Analog Output with crimp terminals
MC-GAOX82	51304638-750	51304638-775	Redundant Analog Output with crimp terminals

Continued on next page

6.2 Model Numbers, Continued

Conformal coated model list, continued

Table 6-2 Conformal Coated Assembly Model Numbers, Continued

Model Number	Non CE Compliant Part Number	CE Compliant Part Number	Description
Galvanically Isolated FTAs, continued			
MC-GDID12	51304640-150	51304640-175	Digital Input with compression terminals
MC-GDID13	51304728-150	51304728-175	Digital Input with compression terminals
MC-GDID82	51304640-350	51304640-375	Digital Input with crimp terminals
MC-GDID83	51304728-350	51304728-375	Digital Input with crimp terminals
MC-GDOD12	51304642-150	51304642-175	24 Vdc Digital Output with compression terminals
MC-GDOD82	51304642-350	51304642-375	24 Vdc Digital Output with crimp terminals
MC-GDOL12	51304736-150	51304736-175	24 Vdc Digital Output with compression terminals
MC-GDOL82	51304736-350	51304736-375	24 Vdc Digital Output with crimp terminals
MC-GLFD02	51304732-150	51304732-175	Combiner Panel
MC-GMAR52	51304646-150	51309156-175	Marshalling Panel
MC-GPRD02	51304644-150	51304644-175	Power Distribution Assembly
I/O Link Extender			
MC-IOLM02			Standard I/O Link Extender—Local Card File
	N/A	51304419-150	Standard I/O Link Extender Card
	N/A	51201557-350	Standard I/O Link Extender Coupler
MC-IOLX02			Standard I/O Link Extender—Remote Card File
	N/A	51304419-150	Standard I/O Link Extender Card
	N/A	51201557-150	Standard I/O Link Extender Coupler
MC-ILD03			Long Distance I/O Link Extender
	N/A	51304532-150	Long Distance I/O Link Extender Card
	N/A	51309208-150	Long Distance I/O Link Extender Coupler

Continued on next page

6.2 Model Numbers, Continued

Conformal coated model list, continued

Table 6-2 Conformal Coated Assembly Model Numbers, Continued

Model Number	Non CE Compliant Part Number	CE Compliant Part Number	Description
Card Files			
MC-PMFR02	51401548-150	N/A	Card File Assembly for 2 PMMs or APMMs and 5 IOPs
MC-PMFX02	51401547-150	N/A	Card File Assembly for 1 PMM or APMM and 10 IOPs
MC-IOFX02	51401608-150	N/A	Card File Assembly for 15 IOPs
MC-PMFR03	N/A	51404212-150	Card File Assembly for 2 PMMs or APMMs and 5 IOPs
MC-PMFX03	N/A	51404211-150	Card File Assembly for 1 PMM or APMM and 10 IOPs
MC-IOFX03	N/A	51404210-150	Card File Assembly for 15 IOPs
PMM Card Sets			
MC-PMMX02			Nonredundant PMM Card Set
	51304685-250	N/A	Communication Card
	51303979-450	N/A	I/O Link Interface Card
	51304518-250	N/A	Control Card
	51304163-350	N/A	Modem Card
	51304260-350	N/A	Redundancy Driver Card
MC-PMMR02			Redundant PMM Card Set
	51304685-250	N/A	Communication Card
	51303979-450	N/A	I/O Link Interface Card
	51303982-450	N/A	Control Card
	51304163-350	N/A	Modem Card
	51304501-150	N/A	Redundancy Driver Card

Continued on next page

6.2 Model Numbers, Continued

Conformal coated model list, continued

Table 6-2 Conformal Coated Assembly Model Numbers, Continued

Model Number	Non CE Compliant Part Number	CE Compliant Part Number	Description
APMM Card Sets			
MC-APMS01			Nonredundant APMM Card Set
	N/A	51304685-150	Communication Card
	N/A	51303979-550	I/O Link Interface Card
	N/A	51304518-150	Control Card
	N/A	51304493-250	Modem Card
	N/A	51304190-350	Jumper Card
MC-APMR01			Redundant APMM Card Set
	N/A	51304685-150	Advanced Communication Card
	N/A	51303979-550	Advanced I/O Link Interface Card
	N/A	51304518-150	Advanced Control Card
	N/A	51304493-250	Modem Card
	N/A	51304190-350	Jumper Card

Continued on next page

6.2 Model Numbers, Continued

Conformal coated model list, continued

Table 6-2 Conformal Coated Assembly Model Numbers, Continued

Model Number	Non CE Compliant Part Number	CE Compliant Part Number	Description
Power System			
MC-PSSX03	N/A	51401217-450	Power System, single Power Supply Module
MC-PSSX04	N/A	51404174-175	Power System, single Power Supply Module
MC-PSRX03	N/A	51401217-550	Power System, redundant Power Supply Modules
MC-PSRX04	N/A	51404174-275	Power System, redundant Power Supply Modules
MC-PSRB03	N/A	51401217-650	Power System, redundant PSMs with Battery Pack
MC-PSRB04	N/A	51404174-375	Power System, redundant PSMs with Battery Pack
MC-PAS121	51401140-150	N/A	AC Only Power System, single PSM, 115 Vac 16 A
MC-PAR121	51401140-250	N/A	AC Only Power System, redund PSMs, 115 Vac 16 A
MC-PAS221	51401140-350	N/A	AC Only Power System, single PSM, 230 Vac 16 A
MC-PAR221	51401140-450	N/A	AC Only Power System, redund PSMs, 230 Vac 16 A
MC-PAS111	51401140-550	N/A	AC Only Power System, single PSM, 115 Vac 8 A
MC-PAR111	51401140-650	N/A	AC Only Power System, redund PSMs, 115 Vac 8 A
MC-PAS211	51401140-750	N/A	AC Only Power System, single PSM, 230 Vac 8 A
MC-PAR211	51401140-850	N/A	AC Only Power System, redund PSMs, 230 Vac 8 A
Standby Manual Devices			
MC-SMAC02	51401277-200	N/A	Analog Output Standby Manual Device w/case, cable
MC-SMDC02	51304526-100	N/A	Digital Output Standby Manual Device w/case, cable
MC-SMDX02	51304527-100	N/A	Digital Output Standby Manual Device with cable
Cabinet Fan Assemblies			
MC-FAN511			Cabinet Fan Assembly with alarm, 240 Vac
	N/A	51303940-250	Cabinet Fan Assembly with alarm, 240 Vac
MC-FAN611			Cabinet Fan Assembly with alarm, 120 Vac
	N/A	51303940-150	Cabinet Fan Assembly with alarm, 120 Vac

6.2 Model Numbers, Continued

Conformal coated model list, continued

Table 6-2 Conformal Coated Assembly Model Numbers, Continued

Model Number	Non CE Compliant Part Number	CE Compliant Part Number	Description
Miscellaneous			
MC-CBSS01			NEMA 4x Stainless Steel Enclosure (.6 m W x .5 m D x .6 m H) with Left 7-Slot card file
MC-CBSS02			NEMA 4x Stainless Steel Enclosure (.6 m W x .5 m D x .6 m H) with Right 7-Slot card file

Section 7 – CE Compliance

7.1 Overview

Section contents The topics covered in this section are:

	Topic	See Page
7.1	Overview.....	117
7.2	Card Files.....	118
7.3	APMM Cards.....	119
7.4	IOPs.....	119
7.5	FTAs.....	122
7.6	I/O Link Extender.....	130
7.7	IOP to FTA Cables.....	131
7.8	Power Cables.....	132
7.9	I/O Link Interface Cables.....	133
7.10	UCN Trunk Cable Taps.....	134
7.11	Cabinets.....	136

Introduction In an effort to meet CE Compliance directives, card files, Advanced Process Manager Module (APMM) cards, Field Termination Assemblies (FTAs), Power Systems, and cables, namely IOP to FTA cables, power cables, and I/O Link Interface cables, are available and identified either by the model number or by the assembly part number.

Hardware differences Where applicable, this section describes general differences between the CE Compliant hardware and non-CE Compliant hardware.

Also discussed are the hardware combinations and rules that must be considered for CE Compliance.

CE Compliant hardware identification Finally, where applicable, each subsection that is devoted to a particular type of hardware identifies the CE Compliant and the non-CE Compliant hardware.

Master Reference Ground The use of a Master Reference Ground (MRG), which is separate from Safety Ground, is not acceptable for a CE Compliant installation. References to Master Reference Ground must be ignored and a single Safety Ground must be substituted.

CE Compliant installation Only recommended CE Compliant hardware, cabling, and practices must be considered for a CE Compliant installation. Install only a single-ground system.

7.2 Card Files

Introduction	<p>All three card file types are available as CE Compliant. The CE Compliant models have four unique features. They are</p> <ul style="list-style-type: none">• Filtered backplane IOP connectors• An IOP connector ground panel• A UCN connector shield enclosure• A rear backplane shield
FTA connector ground panel	<p>The backplane ground panel provides a ground plane for the body of the IOP connectors. The body of the connector in turn provides ground for the IOP to FTA cable shield when mated with the IOP connector.</p>
UCN connector shield enclosure	<p>The UCN connector shield surrounds the UCN connectors to provide EMI protection.</p>
Rear backplane shield panel	<p>Like the UCN connector shield enclosure, the backplane shield panel provides EMI protection at the back of the backplane.</p>
IOP to FTA cables	<p>Both the model MU-KFTAxx and MU-KFTSxx IOP to FTA cables can be used with both the CE Compliant and non-CE Compliant card files; however, only the CE Compliant card file models and the model MU-KFTSxx IOP to FTA cables together are acceptable as CE Compliant.</p>
Model list	<p>Table 7-1 lists the model numbers of the CE Compliant non-conformally coated and conformally coated card files. All models are available without conformal coating (MU) and with conformal coating (MC).</p>

Table 7-1 Card Files

Card File Description	Non-Conformally Coated Model Number	Conformally Coated Model Number
IOP	MU-IOFX03	MC-IOFX03
Single PMM/APMM	MU-PMFX03	MC-PMFX03
Redundant PMMs/APMMs	MU-PMFR03	MC-PMFR03

7.3 APMM Cards

Introduction The Advanced Process Manager Module (APMM) card set is CE Compliant.

Conformal coating The APMM card set is available with and without conformal coating.

7.4 IOPs

Introduction Only the model MU-PAOX03 (MC-PAOX03) Analog Output IOP is available in a CE Compliant and non-CE Compliant version. All other IOP models are CE Compliant only.

Conformal coating All IOP cards are available with and without conformal coating.

Continued on next page

7.4 IOPs, Continued

Nonconformally coated IOPs Table 7-2 lists the model numbers of the CE Compliant and non-CE Compliant IOP cards that are not conformal coated. Model numbers and part numbers identify the assemblies.

Table 7-2 IOPs – Nonconformally Coated

Description	Model Number	Non-CE Compliant Part Number	CE Compliant Part Number
LLAI	MU-PAIL02	N/A	51304481-100
LLMux	MU-PLAM02	N/A	51304362-100
H LAI	MU-PAIH03	N/A	51304754-100
STI	MU-PSTX02	N/A	51304516-100
STIM	MU-PSTX03	N/A	51304516-200
AO	MU-PAOX03	51304672-100	51309152-125
AO	MU-PAOY22	N/A	80363969-100
DI	MU-PDIX02	N/A	51304485-100
DI	MU-PDIY22	N/A	80363972-100
DISOE	MU-PDIS11	N/A	51304690-100
DO	MU-PDOX02	N/A	51304487-100
DO	MU-PDOY22	N/A	80363975-100
PI	MU-PPIX02	N/A	51304386-100
SDI	MU-PSDX02	N/A	51304362-200
SI	MU-PSIM11	N/A	51304362-300

Continued on next page

7.4 IOPs, Continued

Conformally coated IOPs

Table 7-3 lists the model numbers of the CE Compliant and non-CE Compliant IOP cards that are conformally coated. Model numbers and part numbers identify the assemblies.

Table 7-3 IOPs – Conformally Coated

IOP Type	Model Number	Non-CE Compliant Part Number	CE Compliant Part Number
LLAI	MC-PAIL02	N/A	51304481-150
LLMux	MC-PLAM02	N/A	51304362-150
HLAI	MC-PAIH03	N/A	51304754-150
STI	MC-PSTX02	N/A	51304516-150
STIM	MC-PSTX03	N/A	51304516-250
AO	MC-PAOX03	51304672-150	51309152-175
AO	MC-PAOY22	N/A	80363969-150
DI	MC-PDIX02	N/A	51304485-150
DI	MC-PDIY22	N/A	80363972-150
DISOE	MC-PDIS11	N/A	51304690-150
DO	MC-PDOX02	N/A	51304487-150
DO	MC-PDOY22	N/A	80363975-150
PI	MC-PPIX02	N/A	51304386-150
SDI	MC-PSDX02	N/A	51304362-250
SI	MC-PSIM11	N/A	51304362-350

7.5 FTAs

Introduction

Many types of FTAs are available as CE Compliant. Some are identified by a model number that is different than the model number for the non-CE Compliant FTA. Other CE Compliant FTA types have the same model number as the non-CE Compliant FTA, but are generally identified by the tab number of the part number that ends in “25.”

The CE Compliant FTAs feature filtered connectors to interface the CE Compliant model MU-KFTSxx IOP to FTA cable(s).

Conformal coating

All FTAs are available with and without conformal coating.

Nonconformally coated FTAs

Table 7-4 is a list of CE Compliant and non-CE Compliant FTAs that are not conformally coated. Model numbers and part numbers identify the assemblies.

Table 7-4 Field Termination Assemblies – Nonconformally Coated

Description	Model Number	Non-CE Compliant Part Number	CE Compliant Part Number
LLAI	MU-TAIL02	51304437-100	N/A
LLMux RTD	MU-TAMR02	51304477-100	N/A
LLMux RTD	MU-TAMR03	N/A	51309218-125
LLMux TC	MU-TAMT02	51401491-100	N/A
LLMux TC	MU-TAMT03	N/A	51309223-125
LLMux TC Remote	MU-TAMT12	51401573-100	N/A
LLMux TC Remote	MU-TAMT13	N/A	51309213-125
HLAI/STI	MU-TAIH02	51304453-100	N/A
HLAI/STI	MU-TAIH12	51304337-100	N/A
HLAI/STI	MU-TAIH22	80366195-100	N/A
HLAI/STI	MU-TAIH52	51304337-200	N/A
HLAI/STI	MU-TAIH62	80366192-100	N/A
HLAI	MU-TAIH03	N/A	51309136-125
HLAI	MU-TAIH13	N/A	51309138-125
HLAI	MU-TAIH23	N/A	80366195-125
HLAI	MU-TAIH53	N/A	51309138-225

Continued on next page

7.5 FTAs, Continued

Nonconformally coated FTAs, continued

Table 7-4 Field Termination Assemblies—Nonconformally Coated, Continued

Description	Model Number	Non-CE Compliant Part Number	CE Compliant Part Number
STI	MU-TSTX03	N/A	51309136-125
STI	MU-TSTX13	N/A	51309138-125
STI	MU-TSTX53	N/A	51309138-225
AO	MU-TAOX02	51304476-100	51304476-125
AO	MU-TAOX12	51304335-100	51304335-125
AO	MU-TAOX52	51304335-200	51304335-225
AO	MU-TAOY22	80366177-100	80366481-125
AO	MU-TAOY23	80366177-200	N/A
AO	MU-TAOY52	80364007-100	80366484-125
AO	MU-TAOY53	80364007-200	N/A
24 Vdc DI	MU-TDID12	51304441-100	51304441-125
24 Vdc DI	MU-TDID52	51304441-200	51304441-225
24 Vdc DI	MU-TDID72	51303928-100	N/A
24 Vdc DI	MU-TDIY22	80366180-100	80366180-125
24 Vdc DI	MU-TDIY62	80364010-100	80364010-125
120 Vac DI	MU-TDIA12	51304439-100	51304439-125
120 Vac DI	MU-TDIA52	51304439-200	51304439-225
120 Vac DI	MU-TDIA72	51303930-100	N/A
240 Vac DI	MU-TDIA22	51304431-100	51304431-125
240 Vac DI	MU-TDIA62	51304431-200	51304431-225
24 Vdc Nonisolated DO	MU-TDON12	51304446-100	N/A
24 Vdc Nonisolated DO	MU-TDON52	51304446-200	N/A
24 Vdc Isolated DO	MU-TDOY22	80366183-100	80366183-125
24 Vdc Isolated DO	MU-TDOY62	80364013-100	80364013-125

Continued on next page

7.5 FTAs, Continued

Nonconformally coated FTAs, continued

Table 7-4 Field Termination Assemblies—Nonconformally Coated, Continued

Description	Model Number	Non-CE Compliant Part Number	CE Compliant Part Number
3-30 Vdc SS DO	MU-TDOD12	51304423-100	N/A
3-30 Vdc SS DO	MU-TDOD13	51304650-100	N/A
3-30 Vdc SS DO	MU-TDOD14	N/A	51309153-125
3-30 Vdc SS DO	MU-TDOD52	51304423-200	N/A
3-30 Vdc SS DO	MU-TDOD53	51304650-200	N/A
3-30 Vdc SS DO	MU-TDOD54	N/A	51309153-225
31-200 Vac SS DO	MU-TDOD22	51304428-100	N/A
31-200 Vac SS DO	MU-TDOD23	N/A	51309154-125
31-200 Vac SS DO	MU-TDOD62	51304428-200	N/A
31-200 Vac SS DO	MU-TDOD63	N/A	51309154-225
120/240 Vac SS DO	MU-TDOA12	51304408-100	N/A
120/240 Vac SS DO	MU-TDOA13	51304648-100	51304648-125
120/240 Vac SS DO	MU-TDOA52	51304408-200	N/A
120/240 Vac SS DO	MU-TDOA53	51304648-200	51304648-225
120 Vac/125 Vdc Relay DO	MU-TDOR12	51304443-100	51309148-125
120 Vac/125 Vdc Relay DO	MU-TDOR52	51304443-200	51309148-225
240 Vac/125 Vdc Relay DO	MU-TDOR22	51304427-100	51309150-125
240 Vac/125 Vdc Relay DO	MU-TDOR62	51304427-200	51309150-225
240 Vac/125 Vdc Relay DO	MU-TDOY23	80366189-100	80366189-125
240 Vac/125 Vdc Relay DO	MU-TDOY63	80366185-100	80366185-125
PI	MU-TPIX12	51304084-100	51304084-125
PI	MU-TPIX52	51304084-200	51304084-225

Continued on next page

7.5 FTAs, Continued

Nonconformally coated FTAs, continued

Table 7-4 Field Termination Assemblies—Nonconformally Coated, Continued

Description	Model Number	Non-CE Compliant Part Number	CE Compliant Part Number
SDI – Toledo	MU-TSDT02	51303932-201	N/A
SDI – Manual/Auto	MU-TSDM02	51303932-202	N/A
SDI – Toledo	MU-TSDU02	51303932-203	N/A
SI – Modbus	MU-TSIM12	51303932-401	51303932-426
SI – Allen-Bradley	MU-TSIA12	51303932-403	51303932-428
Power Adapter	MU-TLPA02	51304467-100	51309204-125
DI Power Dist Assembly	MU-TPRD02	51304425-100	51304425-125
GI Power Dist Assembly	MU-GPRD02	51304644-100	51304644-125
GI HLAI/STI	MU-GAIH13	51304718-100	51304718-125
GI HLAI/STI	MU-GAIH14	51304730-100	51304730-125
GI HLAI/STI	MU-GAIH82	51304718-300	51304718-325
GI HLAI/STI	MU-GAIH83	51304718-300	51304718-325
GI HLAI/STI	MU-GAIH84	51304730-300	51304730-325
GI AO	MU-GAOX12	51304638-500	51304638-525
GI AO	MU-GAOX72	51304638-300	51304638-325
GI AO	MU-GAOX82	51304638-700	51304638-725
GI 24 Vdc DI	MU-GDID12	51304640-100	51304640-125
GI 24 Vdc DI	MU-GDID13	51304728-100	51304728-125
GI 24 Vdc DI	MU-GDID82	51304640-300	51304640-325
GI 24 Vdc DI	MU-GDID83	51304728-300	51304728-325
GI 24 Vdc DO	MU-GDOD12	51304642-100	51304642-125
GI 24 Vdc DO	MU-GDOD82	51304642-300	51304642-325
GI DO with LFD	MU-GDOL12	51304736-100	51304736-125
GI DO with LFD	MU-GDOL82	51304736-300	51304736-325
GI Combiner Panel	MU-GLFD02	51304732-100	51304732-125
GI Marshalling Panel	MU-GMAR52	51304646-100	51309156-125

Continued on next page

7.5 FTAs, Continued

Conformally coated FTAs

Table 7-5 is a list of CE Compliant and non-CE Compliant FTAs that are conformally coated. Model numbers and part numbers identify the assemblies.

Table 7-5 Field Termination Assemblies—Conformally Coated

Description	Model Number	Non-CE Compliant Part Number	CE Compliant Part Number
LLAI	MC-TAIL02	51304437-150	N/A
LLMux RTD	MC-TAMR02	51304477-150	N/A
LLMux RTD	MC-TAMR03	N/A	51309218-175
LLMux TC	MC-TAMT02	51401491-150	N/A
LLMux TC	MC-TAMT03	N/A	51309223-175
LLMux TC Remote	MC-TAMT12	51401573-150	N/A
LLMux TC Remote	MC-TAMT13	N/A	51309213-175
HLAI/STI	MC-TAIH02	51304453-150	N/A
HLAI/STI	MC-TAIH12	51304337-150	N/A
HLAI/STI	MC-TAIH22	80366195-150	N/A
HLAI/STI	MC-TAIH52	51304337-250	N/A
HLAI/STI	MC-TAIH62	80366192-150	N/A
HLAI	MC-TAIH03	N/A	51309136-175
HLAI	MC-TAIH13	N/A	51309138-175
HLAI	MC-TAIH23	N/A	80366195-175
HLAI	MC-TAIH53	N/A	51309138-275
STI	MC-TSTX03	N/A	51309136-175
STI	MC-TSTX13	N/A	51309138-175
STI	MC-TSTX53	N/A	51309138-275

Continued on next page

7.5 FTAs, Continued

Conformally coated FTAs, continued

Table 7-5 Field Termination Assemblies—Conformally Coated, Continued

Description	Model Number	Non-CE Compliant Part Number	CE Compliant Part Number
AO	MC-TAOX02	51304476-150	51304476-175
AO	MC-TAOX12	51304335-150	51304335-175
AO	MC-TAOX52	51304335-250	51304335-275
AO	MC-TAOY22	80366177-150	80366481-175
AO	MC-TAOY23	80366177-250	N/A
AO	MC-TAOY52	80364007-150	80366484-175
AO	MC-TAOY53	80364007-250	N/A
24 Vdc DI	MC-TDID12	51304441-150	51304441-175
24 Vdc DI	MC-TDID52	51304441-250	51304441-275
24 Vdc DI	MC-TDID72	51303928-150	N/A
24 Vdc DI	MC-TDIY22	80366180-150	80366180-175
24 Vdc DI	MC-TDIY62	80364010-150	80364010-175
120 Vac DI	MC-TDIA12	51304439-150	51304439-175
120 Vac DI	MC-TDIA52	51304439-250	51304439-275
120 Vac DI	MC-TDIA72	51303930-150	N/A
240 Vac DI	MC-TDIA22	51304431-150	51304431-175
240 Vac DI	MC-TDIA62	51304431-250	51304431-275
24 Vdc Nonisolated DO	MC-TDON12	51304446-150	N/A
24 Vdc Nonisolated DO	MC-TDON52	51304446-250	N/A
24 Vdc Isolated DO	MC-TDOY22	80366183-150	80366183-175
24 Vdc Isolated DO	MC-TDOY62	80364013-150	80364013-175
3-30 Vdc SS DO	MC-TDOD12	51304423-150	N/A
3-30 Vdc SS DO	MC-TDOD13	51304650-150	N/A
3-30 Vdc SS DO	MC-TDOD14	N/A	51309153-175
3-30 Vdc SS DO	MC-TDOD52	51304423-250	N/A

Continued on next page

7.5 FTAs, Continued

Conformally coated FTAs, continued

Table 7-5 Field Termination Assemblies—Conformally Coated, Continued

Description	Model Number	Non-CE Compliant Part Number	CE Compliant Part Number
3-30 Vdc SS DO	MC-TDOD53	51304650-250	N/A
3-30 Vdc SS DO	MC-TDOD54	N/A	51309153-275
31-200 Vac SS DO	MC-TDOD22	51304428-150	N/A
31-200 Vac SS DO	MC-TDOD23	N/A	51309154-175
31-200 Vac SS DO	MC-TDOD62	51304428-250	N/A
31-200 Vac SS DO	MC-TDOD63	N/A	51309154-275
120/240 Vac SS DO	MC-TDOA12	51304408-150	N/A
120/240 Vac SS DO	MC-TDOA13	51304648-150	51304648-175
120/240 Vac SS DO	MC-TDOA52	51304408-250	N/A
120/240 Vac SS DO	MC-TDOA53	51304648-250	51304648-275
120 Vac/125 Vdc Relay DO	MC-TDOR12	51304443-150	51309148-175
120 Vac/125 Vdc Relay DO	MC-TDOR52	51304443-250	51309148-275
240 Vac/125 Vdc Relay DO	MC-TDOR22	51304427-150	51309150-175
240 Vac/125 Vdc Relay DO	MC-TDOR62	51304427-250	51309150-275
240 Vac/125 Vdc Relay DO	MC TDOY23	80366189-150	80366189-175
240 Vac/125 Vdc Relay DO	MC TDOY63	80366185-150	80366185-175
PI	MC-TPIX12	51304084-150	51304084-175
PI	MC-TPIX52	51304084-250	51304084-275
SDI – Toledo	MC-TSDT02	51303932-251	N/A
SDI – Manual/Auto	MC-TSDM02	51303932-252	N/A
SDI – Toledo	MC-TSDU02	51303932-253	N/A
SI – Modbus	MC-TSIM12	51303932-451	51303932-471
SI – Allen-Bradley	MC-TSIA12	51303932-453	51303932-478
Power Adapter	MC-TLPA02	51304467-150	51309204-175

Continued on next page

7.5 FTAs, Continued

Conformally coated FTAs, continued

Table 7-5 Field Termination Assemblies—Conformally Coated, Continued

Description	Model Number	Non-CE Compliant Part Number	CE Compliant Part Number
DI Power Dist Assy	MC-TPRD02	51304425-150	51304425-175
GI Power Dist Assy	MC-GPRD02	51304644-150	51304644-175
GI HLAI/STI	MC-GAIH13	51304718-150	51304718-175
GI HLAI/STI	MC-GAIH14	51304730-150	51304730-175
GI HLAI/STI	MC-GAIH83	51304718-350	51304718-375
GI HLAI/STI	MC-GAIH84	51304730-350	51304730-375
GI HLAI	MU-GAIH12	51304636-150	N/A
GI HLAI	MU-GAIH22	51304748-150	51304748-175
GI HLAI	MU-GAIH82	51304636-350	N/A
GI HLAI	MU-GAIH92	51304748-350	51304748-375
GI AO	MC-GAOX02	51304638-150	51304638-175
GI AO	MC-GAOX12	51304638-550	51304638-575
GI AO	MC-GAOX72	51304638-350	51304638-375
GI AO	MC-GAOX82	51304638-750	51304638-775
GI 24 Vdc DI	MC-GDID12	51304640-150	51304640-175
GI 24 Vdc DI	MC-GDID13	51304728-150	51304728-175
GI 24 Vdc DI	MC-GDID82	51304640-350	51304640-375
GI 24 Vdc DI	MC-GDID83	51304728-350	51304728-375
GI 24 Vdc DO	MC-GDOD12	51304642-150	51304642-175
GI 24 Vdc DO	MC-GDOD82	51304642-350	51304642-375
GI DO with LFD	MC-GDOL12	51304736-150	51304736-175
GI DO with LFD	MC-GDOL82	51304736-350	51304736-375
GI Combiner Panel	MC-GLFD02	51304732-150	51304732-175
GI Marshalling Panel	MC-GMAR52	51304646-150	51309156-175

7.6 I/O Link Extender

Introduction

The I/O Link Extender cards and Fiber Optic Coupler modules are CE Compliant. There are no non-CE Compliant versions.

I/O Link Extender adapter kit

The model MU-ILES01 adapter kit must be used to install the Fiber Optic Coupler module in the CE Compliant card files. The kit consists of a connector adapter, shroud, and mounting spacers as illustrated in Figure 7-1. See the *Process Manager I/O Installation* manual for installation instructions.

Figure 7-1 I/O Link Extender Adapter Kit

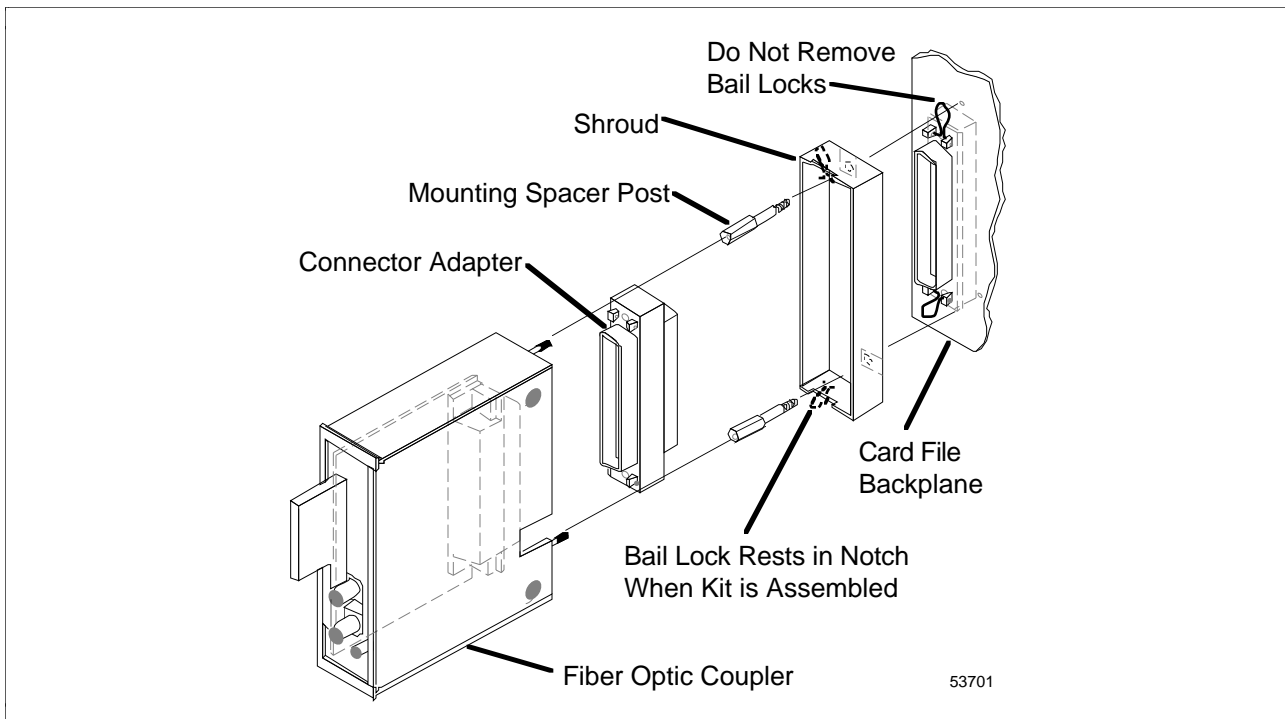

7.7 IOP to FTA Cables

Introduction

Model MU-KFTSxx IOP to FTA cables are shielded cables and are for CE Compliant applications. They are identified by metal connector cases. The non-CE Compliant model MU-KFTAxx IOP to FTA cables are not shielded cables and are identified by the plastic connector case.

CE Compliant

CE Compliance is provided only when the mating connector on the card file backplane is a filtered connector with a metal case and the mating connector on the FTA is a connector with a metal case. The metal connector case grounds the cable shield at both ends of the cable.

Both the card file and the FTA must be CE Compliant assemblies. See subsections 7.2 and 7.5 for a list of CE Compliant assemblies.

Model list

Table 7-6 lists the model numbers of CE Compliant and non-CE Compliant IOP to FTA cables.

Table 7-6 IOP to FTA Cables

Cable Length (Meters/Feet)	Non-CE Compliant Model Number	CE Compliant Model Number
1.0/3.3	Part Number 51201420-001	Part Number 51204033-001
1.5/4.9	Part Number 51201420-915	Part Number 51204033-915
2.0/6.6	MU-KFTA02	MU-KFTS02
3.0/9.8	MU-KFTA03	MU-KFTS03
4.0/13.1	MU-KFTA04	MU-KFTS04
5.0/16.4	MU-KFTA05	MU-KFTS05
6.0/19.7	MU-KFTA06	MU-KFTS06
8.0/26.2	MU-KFTA08	MU-KFTS08
10.0/32.8	MU-KFTA10	MU-KFTS10
15.0/49.2	MU-KFTA15	MU-KFTS15
20.0/65.6	MU-KFTA20	MU-KFTS20
25.0/82.0	MU-KFTA25	MU-KFTS25
30.0/98.4	MU-KFTA30	MU-KFTS30
35.0/114.8	MU-KFTA35	MU-KFTS35
40.0/131.2	MU-KFTA40	MU-KFTS40
45.0/147.6	MU-KFTA45	MU-KFTS45
50.0/164.0	MU-KFTA50	MU-KFTS50

7.8 Power Cables

Introduction

Model MU-KSPRxx power cables are shielded cables. They are identified by shield wires that are terminated with FASTON terminals at each end of the cable. The model MU-KDPRxx power cables are not shielded cables. They have no shield wires.

CE Compliant

The model MU-KSPRxx power cable is CE Compliant when providing power to the model MU-TDPR02 (MC-TDPR02) Digital Input Power Distribution Assembly or the model MU-GDPR02 (MC-GDPR02) Galvanic Isolation Power Distribution Assembly that is located external to the cabinet, or cabinet complex.

The Power Distribution Assembly must be a version of the assembly that has a FASTON terminal to provide a ground point for the model MU-KSPRxx power cable's shield wire. The Power System end of the cable shield must not be grounded and the shield wire must either be clipped or taped to the body of the cable.

Two conductor cable

The model MU-KSPRxx power cable is a 2-conductor cable. It cannot be used to provide power to card files because 3.9 Vdc and 6 Vac are missing from the cable. The model MU-KDPRxx cable must be used to provide power to card files.

Model list

Table 7-7 lists the model numbers of power cables that are CE Compliant and not CE Compliant.

Table 7-7 Power Cables

Cable Length (Meters/Feet)	Non-CE Compliant Model Number	CE Compliant Model Number
1.0/3.3	Part Number 51201397-001	
1.5/4.9	Part Number 51201397-915	
2.0/6.6	MU-KDPR02	
4.0/13.1	MU-KDPR04	
5.0/16.4	MU-KDPR05	MU-KSPR05
10.0/32.8	MU-KDPR10	MU-KSPR10
15.0/49.2	MU-KDPR15	MU-KSPR15
20.0/65.6	MU-KDPR20	MU-KSPR20
30.0/98.4	MU-KDPR30	MU-KSPR30
40.0/131.2	MU-KDPR40	MU-KSPR40
50.0/164.0	MU-KDPR50	MU-KSPR50

7.9 I/O Link Interface Cables

Introduction

There are two types of I/O Link Interface cables.

The I/O Link Interface cables with a part number of 51204042-xxx, where “xxx” represents the length of the cable in meters, are used for a CE Compliance application. The cable is identified by shield wires that are terminated with a FASTON terminal at each connector end of the cable. The cable shield must be grounded at the card file ground plate.

The I/O Link Interface cables with a part number of 51195479-xxx are not used for a CE Compliance application. They have no shield wires. The cable shield is grounded through the cable connector in the card file backplane.

CE Compliance

The I/O Link Interface cables with a part number of 51204042-xxx are for a CE Compliant application when used with model MU-IOFX03 (MC-IOFX03), MU-PMFX03 (MC-PMFX03), and MU-PMFR03 (MC-PMFR03) card files. The card files have FASTON terminals for the cable’s shield wire terminal on the backplane ground panel.

Parts list

Table 7-8 lists the part numbers of I/O Link Interface cables that are CE Compliant and non-CE Compliant. Two cables are provided when ordered by the part number.

Table 7-8 I/O Link Interface Cables

Connector Drops	Non-CE Compliant Part Number	CE Compliant Part Number
2	51195479-100	51204042-100
3	51195479-200	51204042-200
4	51195479-300	51204042-300
5	51195479-400	51204042-400
6	51195479-500	51204042-500

7.10 UCN Trunk Cable Taps

Introduction

A bracket has been added to the UCN cable taps, model numbers MU-NTAP02, MU-NTAP04, and MU-NTAP08, to ensure that the assembly case is properly grounded and CE Compliant. The part numbers for the UCN cable tap models are the same with or without the bracket.

Two-port UCN tap

Figure 7-2 is an illustration of the 2-port UCN cable tap with the added grounding bracket for CE Compliance.

Figure 7-2 Two-Port UCN Cable Tap

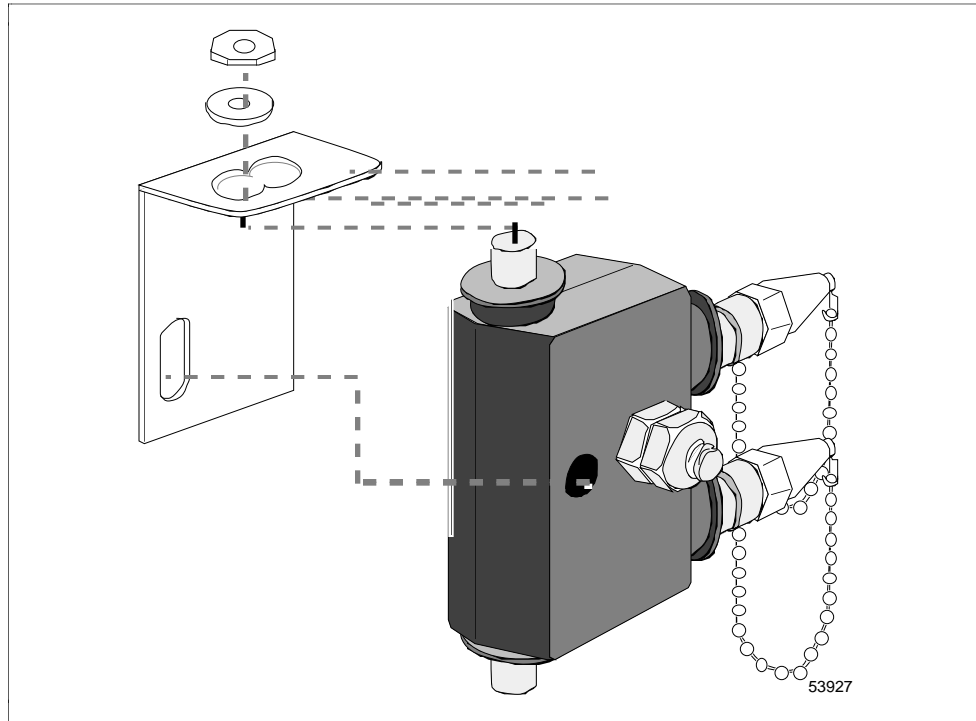

Continued on next page

7.10 UCN Trunk Cable Taps, Continued

Four-port UCN tap

Figure 7-3 is an illustration of the 4-port UCN cable tap with the added grounding bracket for CE Compliance.

Figure 7-3 Four-Port UCN Cable Tap

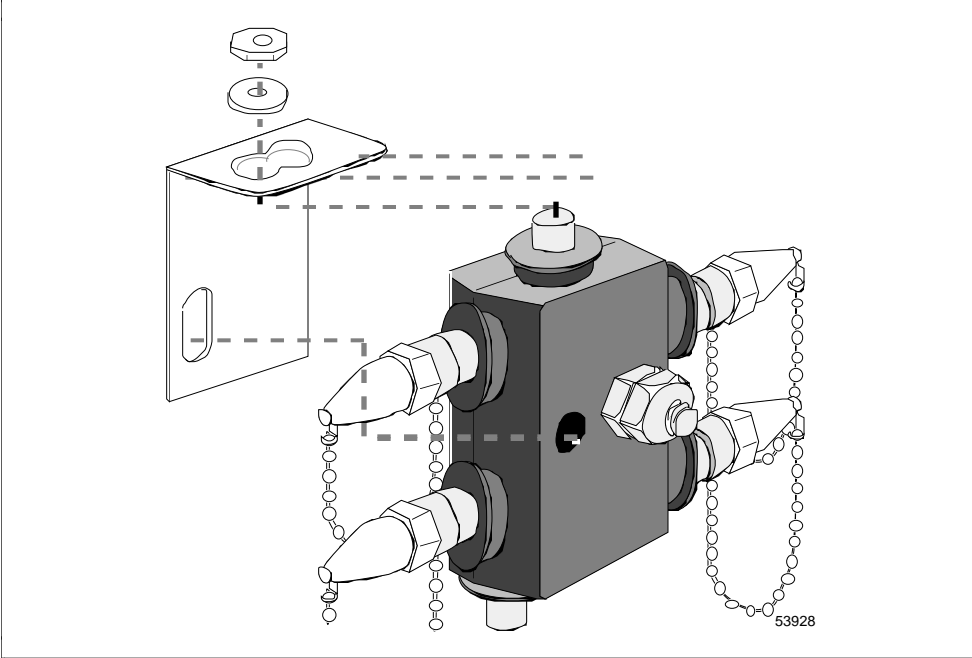

Eight-port UCN tap

Figure 7-4 is an illustration of the 8-port UCN cable tap with the added grounding bracket for CE Compliance.

Figure 7-4 Eight-Port UCN Cable Tap

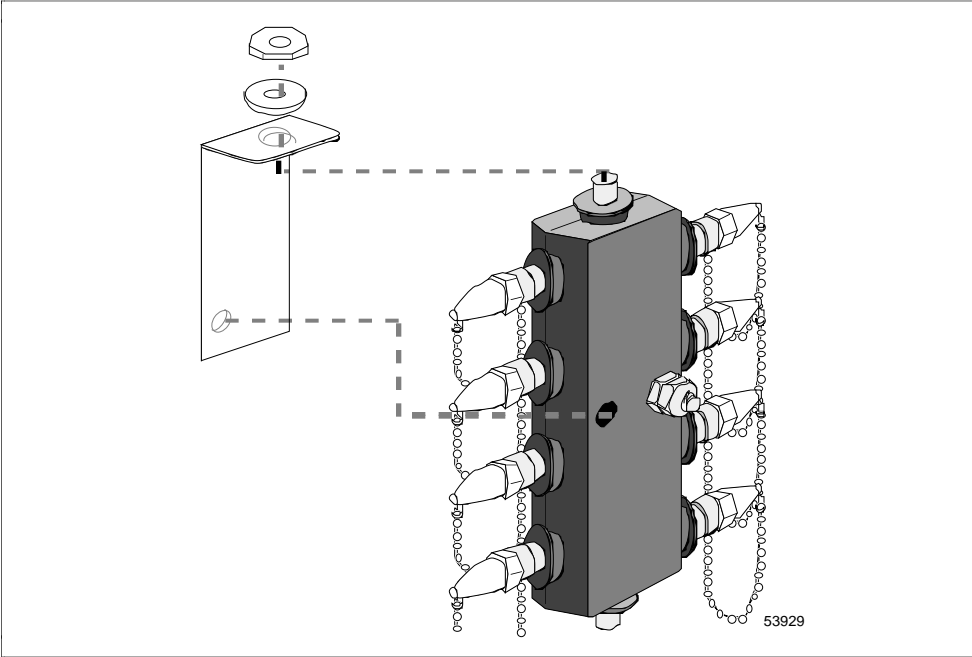

7.11 Cabinets

Introduction

Only the Rittal model MU-CBSX01 and MU-CBDX01 cabinets are CE Compliant; however, older versions of the cabinets are not CE Compliant because the cabinet panels and doors are not properly grounded to the cabinet frame. The CE Compliant cabinets are identified by the abundance of ground straps between the cabinet panels and doors.

Illustrations

See Figures 9-3 and 9-4 in Section 9 for illustrations of the CE Compliant cabinets. Note that all cabinet panels and doors are grounded to the cabinet frame. The cabinet frame must be connected to Safety ground as described in the *TDC 3000X System Site Planning* manual.

UCN drop cable taps

For European site installations, all UCN drop cable taps must be installed inside the cabinet or cabinet complex.

UCN drop cables

Drop cables cannot leave the cabinet unless they are routed in metal conduit that is connected to Safety Ground.

Section 8 – Model MU-CBSM01/MU-CBDM01 Cabinets

8.1 Overview

Section contents The topics covered in this section are:

	Topic	See Page
8.1	Overview.....	137
8.2	Cabinet Description	140
8.3	Card File and Power System Configurations	144
8.4	Card File and Power System Description	146
8.5	FTA Mounting Channel Description	148
8.5.1	Vertical FTA Mounting Channels.....	149
8.5.2	Horizontal FTA Mounting Channel	153
8.6	Cabinet Floor Planning.....	157

Introduction

The Process Manager (PM) and Advanced Process Manager (APM) model MU-CBSM01 and MU-CBDM01 cabinets provide single and dual access, respectively. Access is defined as having a single front door entry or dual front and rear door entry. The model MU-CBSM01 and MU-CBDM01 cabinets are also referred to as Markhon cabinets because Markhon is the manufacturer.

Continued on next page

8.1 Overview, Continued

Single access cabinet

The single-access cabinet has one equipment entry point and that is in the front of the cabinet through a single door. The Process Manager or Advanced Process Manager card files, Power System, and FTA Mounting Channels are installed inside the single-access door. The cabinet side panels can be removed for access. Figure 8-1 is an illustration of a single-access cabinet.

Figure 8-1 Single-Access Cabinet

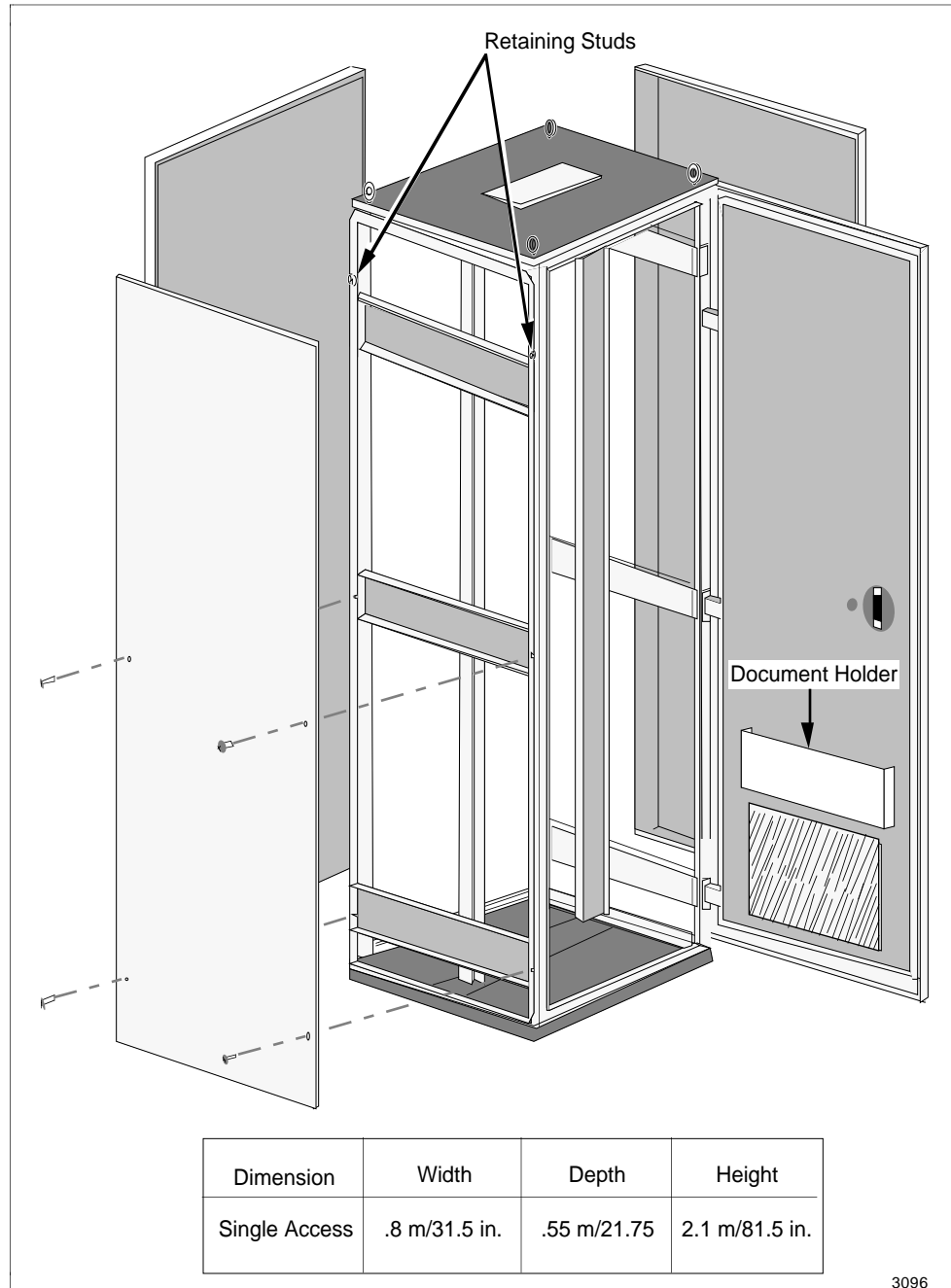

Continued on next page

8.1 Overview, Continued

Dual access cabinet

The dual-access cabinet has two equipment entry points. The Process Manager or Advanced Process Manager card files and the Power System are mounted inside the front access door. The FTA Mounting Channels are normally installed inside the rear door. The cabinet side panels can be removed for access. Figure 8-2 is an illustration of a dual-access cabinet.

Figure 8-2 Dual-Access Cabinet

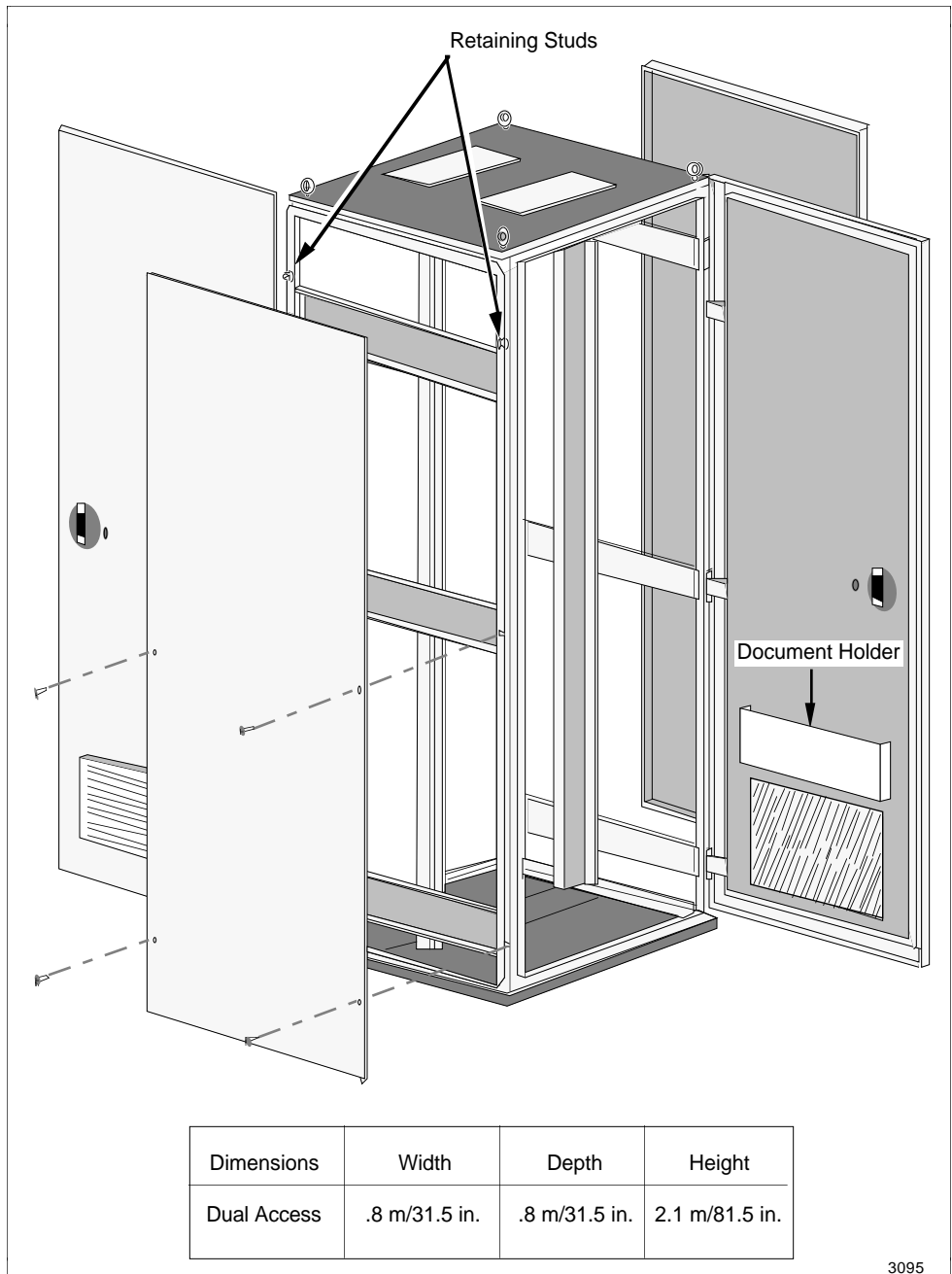

8.2 Cabinet Description

Cabinet dimensions

The single-access cabinet, with the front door, side and rear panels installed, has the following exterior dimensions.

0.8 meters wide x 0.55 meters deep x 2.1 meters high
(31.5 inches x 21.75 inches x 81.5 inches)

The dual-access cabinet, with the front and rear doors, and side panels installed, has the following exterior dimensions.

0.8 meters wide x 0.55 meters deep x 2.1 meters high
(31.5 inches x 21.75 inches x 81.5 inches)

Top and bottom cabinet entry

Both cabinets are NEMA 1 rated and support top and bottom entry for process control wiring. Top entry requires removal of the top panel(s), and/or associated fan assemblies, before entry holes can be punched in the panel. Honeywell will prepunch the holes if specified when ordering the cabinet. Figures 8-3 and 8-4 are illustrations of the bottom cable entry slots for the single and dual cabinets, respectively.

Single access bottom cable entry slots

Figure 8-3 illustrates the bottom cable entry slots in the single-access cabinet.

Figure 8-3 Single-Access Cabinet Bottom Cable Entry Slots

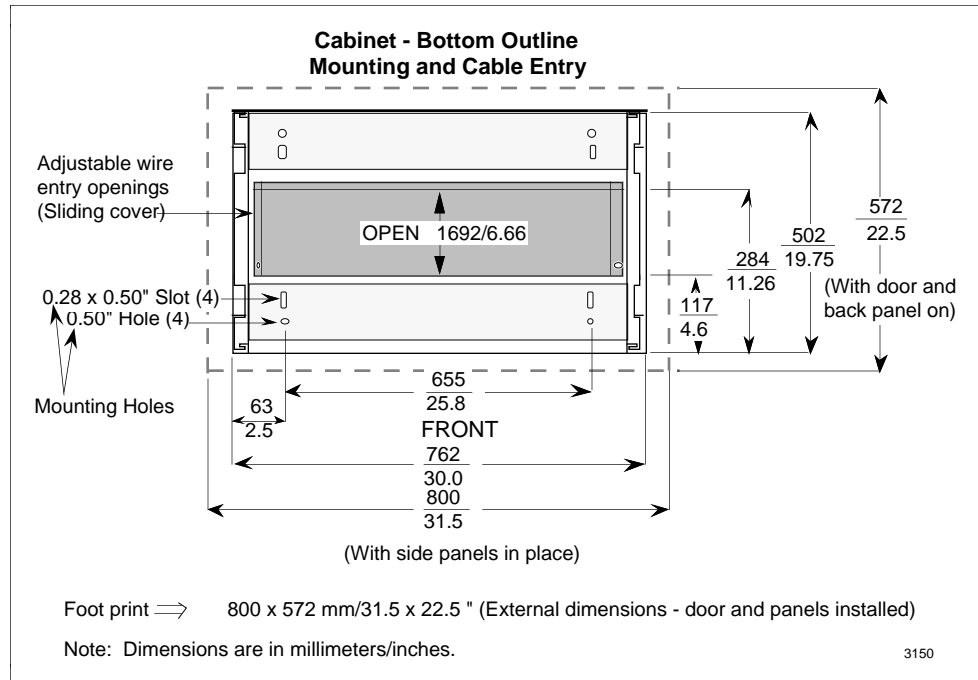

Continued on next page

8.2 Cabinet Description, Continued

Dual access bottom cable entry slots

Figure 8-4 illustrates the bottom cable entry slots in the dual-access cabinet.

Figure 8-4 Dual-Access Cabinet Bottom Cable Entry Slots

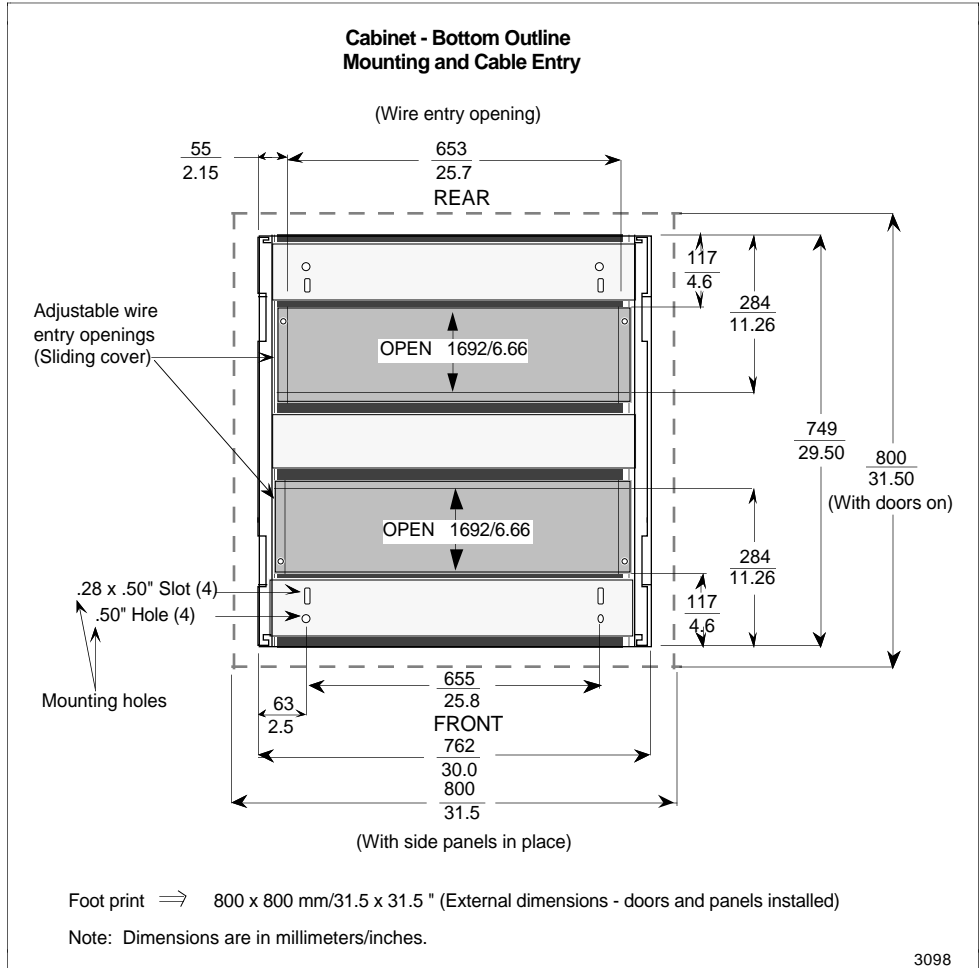

Continued on next page

8.2 Cabinet Description, Continued

Independent cabinet entry	<p>The dual-access cabinet has two independent entry sides. A single-access cabinet has only one entry side. Card files and the Power System, or FTA Mounting Channels can be installed in either side of the cabinet without being constrained by the equipment installed in the other side of the cabinet.</p> <p>The cabinet can be ordered with doors hinged on either the left or right side. The door latch is recessed and lockable.</p>
Cabinet complexing	<p>A maximum of four cabinets can be complexed together without intervening side panels by a complexing kit, Honeywell part number 51109532-200 (single-access cabinet) or 51109532-100 (dual-access cabinet).</p>
NEMA 12	<p>NEMA 12 rated cabinets can be ordered from Honeywell.</p>
Cabinet cooling	<p>Cabinet cooling is accomplished by the use of one or more fan assemblies that are mounted over appropriate cutouts in the cabinet top. Use of a fan assembly is mandatory for a cabinet entry side containing card files or a Power System. Because of power dissipation, the cabinet configuration determines if a fan assembly is required for a cabinet entry side containing Field Termination Assemblies (FTAs). A fan assembly is mandatory when Galvanically Isolated FTAs are installed. Fan assemblies are available for voltages and frequencies noted below.</p> <ul style="list-style-type: none">• Cabinet Fan Assembly (240 Vac, 50/60 Hz)• Cabinet Fan Assembly (120 Vac, 50/60 Hz) <p>A blank plate is available to cover the hole(s) in the top of the cabinet in the event a fan assembly is not needed. The fan opening cabinet-top cover plate is Honeywell part number 51304098-200.</p>

Continued on next page

8.2 Cabinet Description, Continued

Cabinet infrastructure

As shown in Figure 8-5, the cabinet is provided with an internal structure (“infrastructure”) that is capable of accepting card file assemblies, Power Systems, and FTA Mounting Channels. When installing FTAs, FTA Mounting Channels must be specified as discussed in subsection 8.5.

Figure 8-5 Cabinet Interior Dimensions

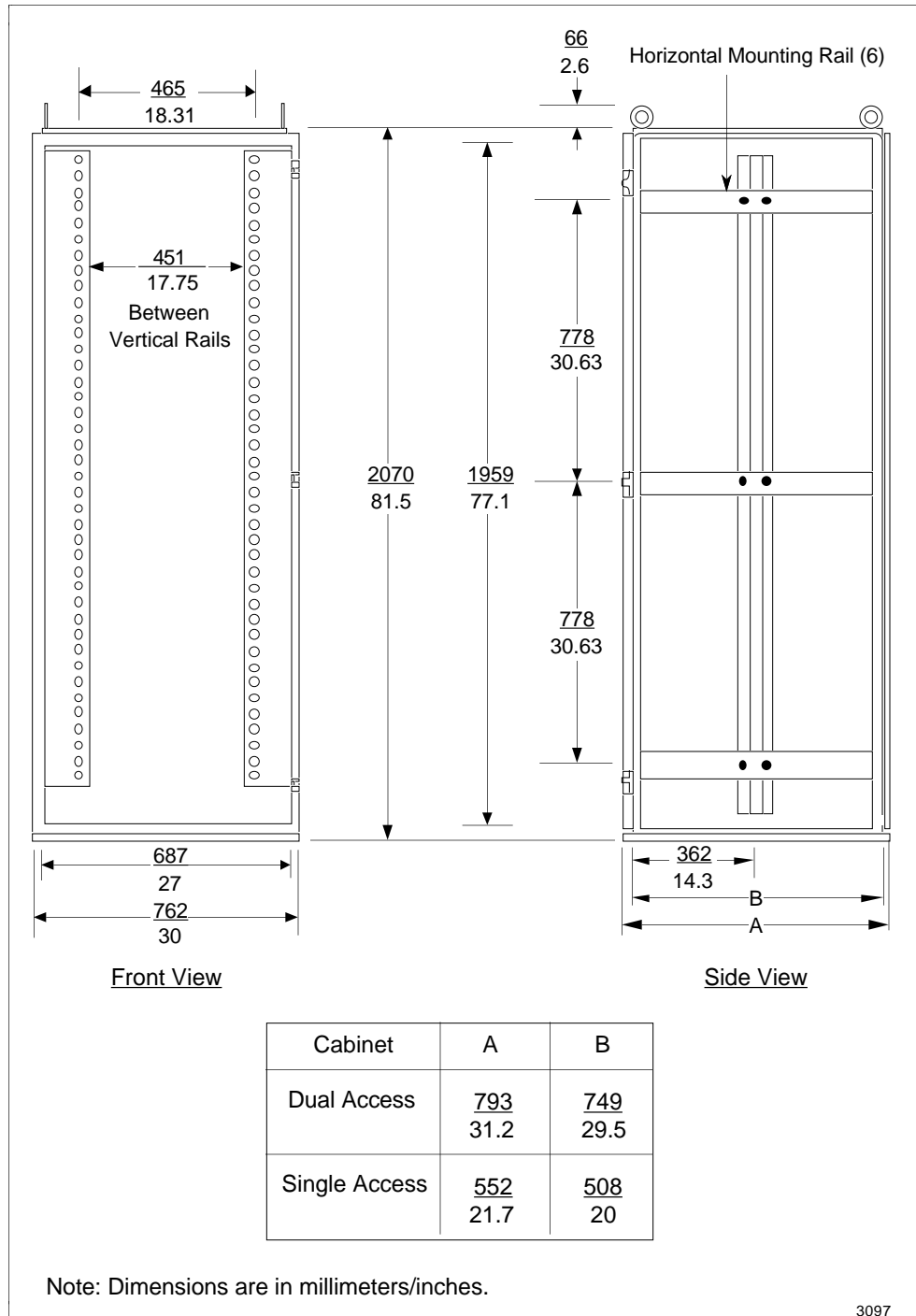

8.3 Card File and Power System Configurations

Cabinet layout

The Process Manager or Advanced Process Manager card files, Power System, and FTA Mounting Channels install in the single- and dual-access cabinets as shown in Figures 8-6 and 8-7, respectively.

Single access cabinet equipment layout

Figure 8-6 illustrates the equipment layout in a single-access cabinet.

Figure 8-6 Typical Single-Access Cabinet Assembly Layout

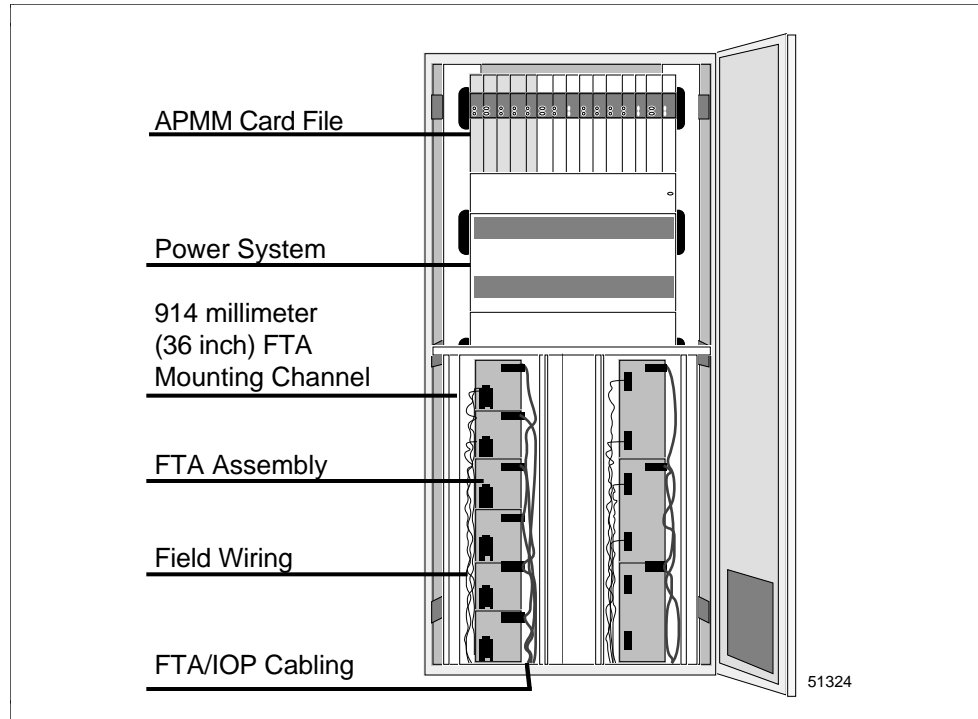

Continued on next page

8.3 Card File and Power System Configurations, Continued

Dual access cabinet equipment layout

Figure 8-7 illustrates the equipment layout in a dual-access cabinet.

Figure 8-7 Typical Dual-Access Cabinet Assembly Layout

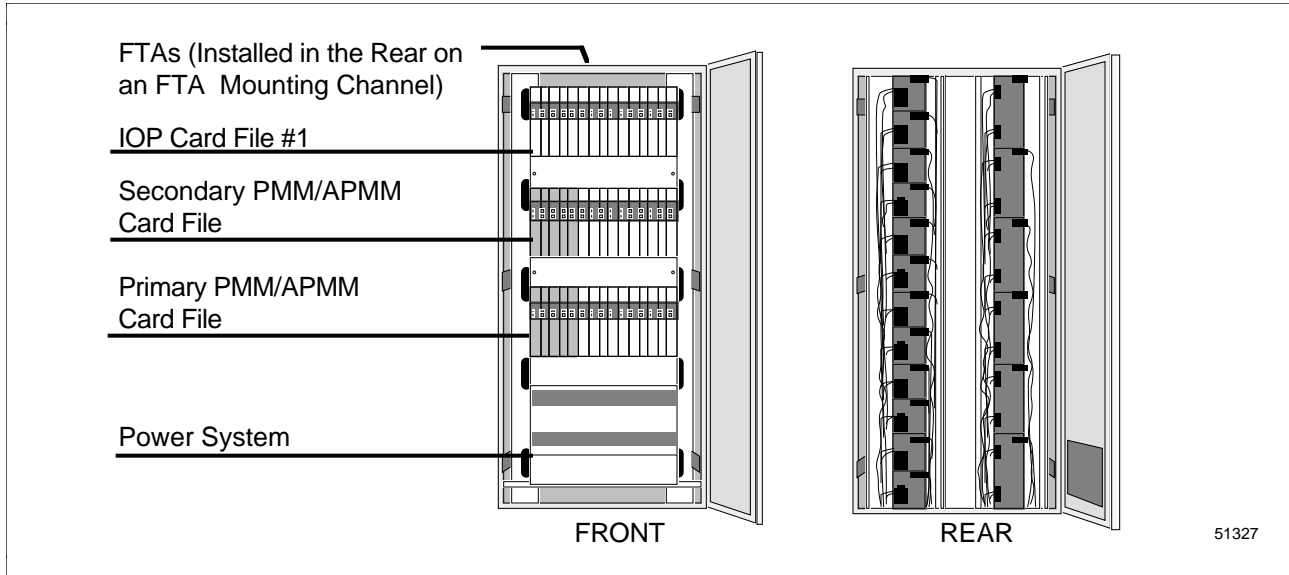

8.4 Card File and Power System Descriptions

Card file dimensions

All three card file assemblies, single PMM/APMM, redundant PMM/APMM, and IOP, are the same size as illustrated in Figure 8-8 and install on a 19" RETMA mounting infrastructure.

Figure 8-8 Card File Installation Dimensions

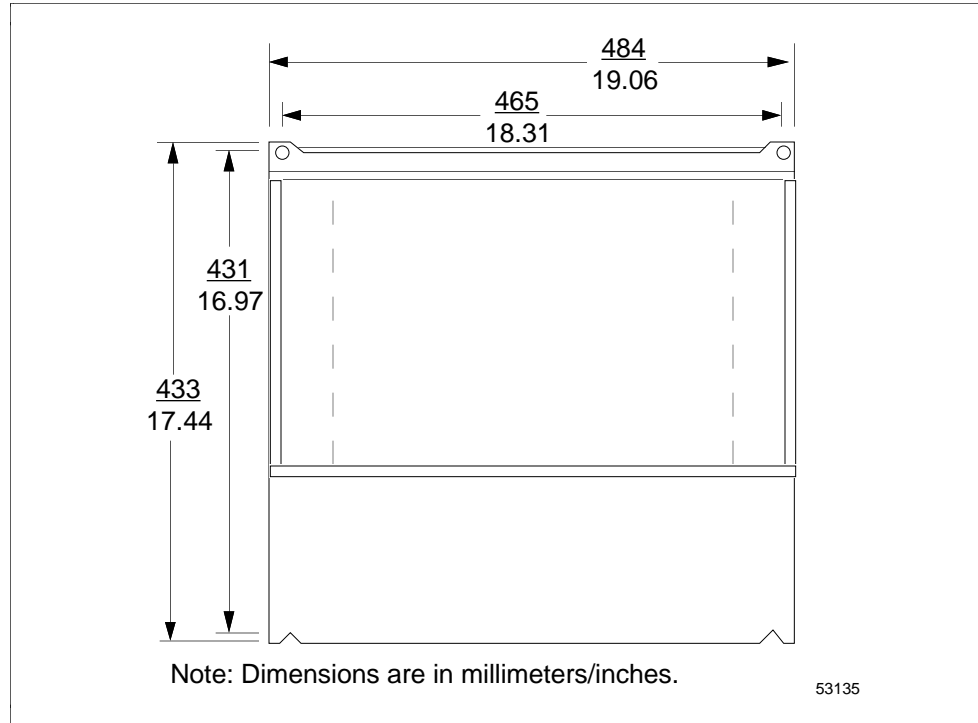

Continued on next page

8.4 Card File and Power System Descriptions, Continued

Power System dimensions

The Power System dimensions are shown in Figure 8-9 and it also installs on a 19" RETMA mounting infrastructure.

Figure 8-9 Power System Installation Dimensions

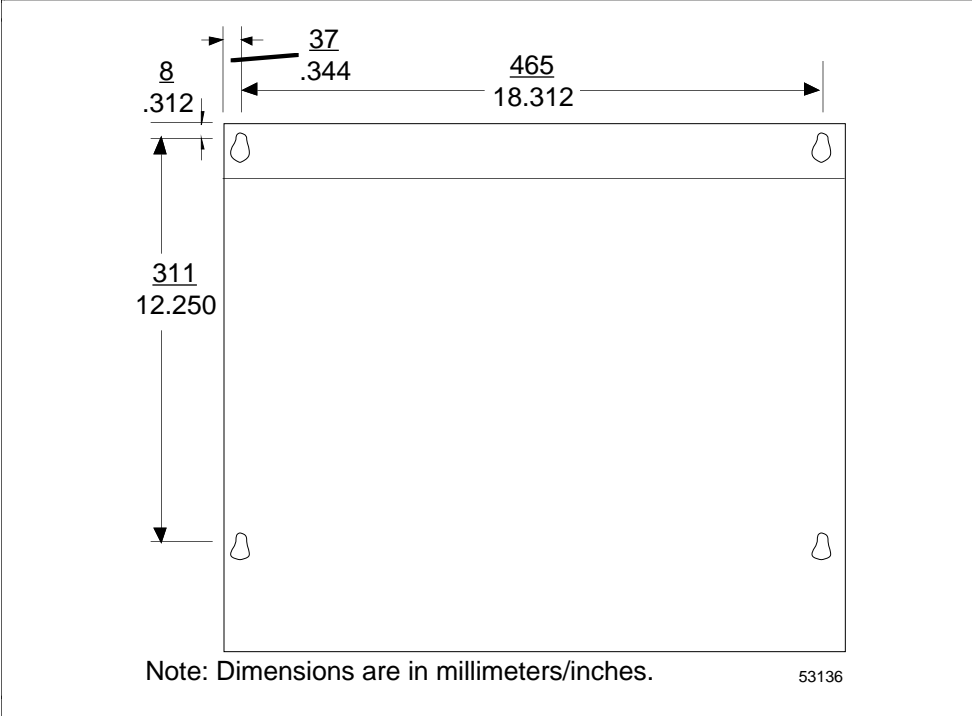

8.5 FTA Mounting Channel Descriptions

Introduction

Field Termination Assemblies (FTAs) are produced in three standard sizes that are dependent on the FTA type and circuit requirements.

Size A 15.20 cm (6.0 in.) x 12.0 cm(4.75 in.)

Size B 30.48 cm (12.1 in.) x 12.0 cm (4.75 in.)

Size C 46.22 cm (18.2 in.) x 12.0 cm (4.75 in.)

They mount on FTA Mounting Channels that are attached to the cabinet's infrastructure.

Three styles of FTA Mounting Channels are available:

- Wide vertical
- Narrow vertical
- Horizontal

Selection is based on whether standard or Galvanically Isolated FTAs are installed in the cabinet.

The FTA Mounting Channels used to mount standard FTAs are vertically oriented in the cabinet and the FTA Mounting Channels used to mount Galvanically Isolated FTAs are horizontally oriented in the cabinet.

8.5.1 Vertical FTA Mounting Channels

Overview

Standard FTAs are mounted on vertically oriented FTA Mounting Channels in the cabinet. The vertical FTA Mounting Channels have two channels (troughs), right and left. Field wiring enters the left channel and connects to the FTAs. The cables connecting the FTAs to their associated IOP(s) or Power distribution Assemblies are routed in the right channel of the FTA Mounting Channel.

FTA Mounting Channel configurations

The vertical FTA Mounting Channel length, approximately 93 centimeters (36 inches) is approximately half the height of the cabinet. The FTA Mounting Channels can be mounted adjacent to each other in this vertical area. The FTA mounting configurations will allow

- up to four narrow channels or
- up to three wide channels.

The FTA Mounting Channel configurations can be mounted adjacent to each other in the area below the Power System in a single-access cabinet as shown in Figure 8-6.

In the dual-access cabinet, one FTA Mounting Channel is normally installed above another, adjacently in pairs, as shown in Figure 8-7.

Continued on next page

8.5.1 Vertical FTA Mounting Channels, Continued

Vertical FTA Mounting Channel configurations

Figure 8-10 illustrates four typical vertical FTA Mounting Channel cabinet configurations.

Figure 8-10 Typical Vertical FTA Mounting Channel Configurations

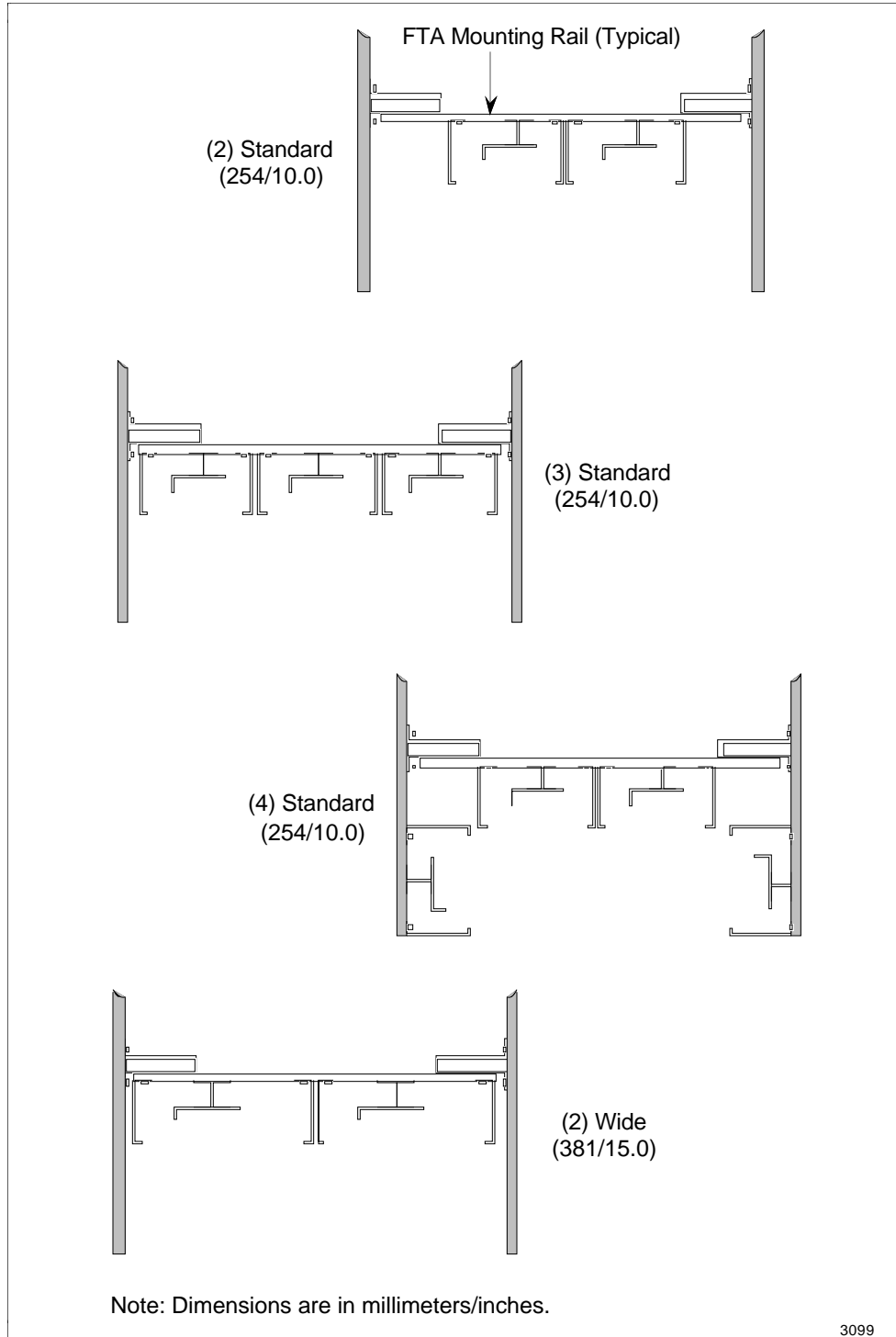

Continued on next page

8.5.1 Vertical FTA Mounting Channels, Continued

FTA Mounting Channel widths

Vertical FTA Mounting Channels are available in two widths:

Standard 25.4 cm (10 in.) W x 10.8 cm (4.25 in.) D x 93 cm (36.6 in.) L

Wide 38.1 cm (15 in.) W x 10.8 cm (4.25 in.) D x 93 cm (36.6 in.) L

Figures 8-11 illustrates the FTA Mounting Channel dimensions.

Figure 8-11 Vertical FTA Mounting Channel Dimensions

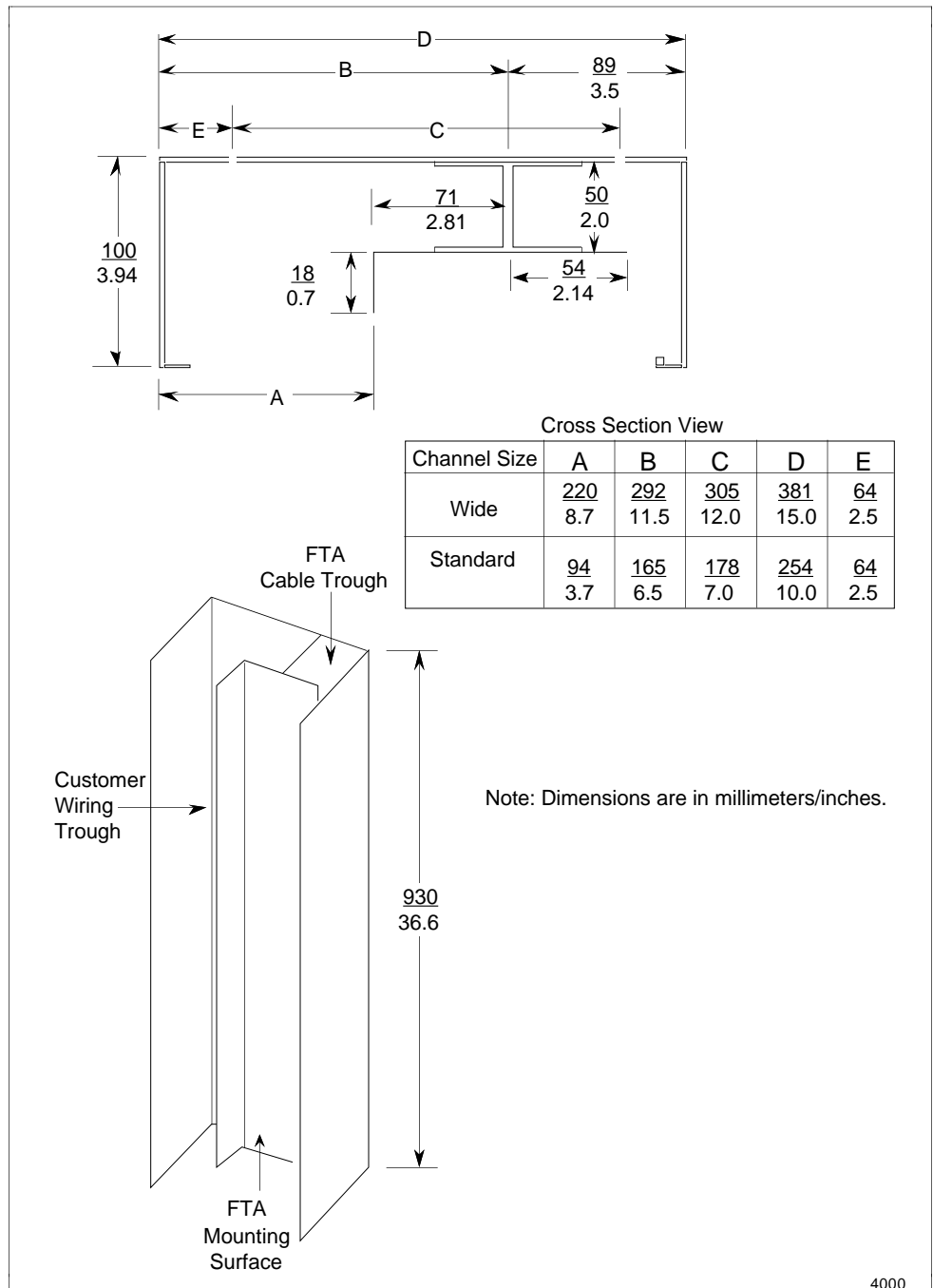

Continued on next page

8.5.1 Vertical FTA Mounting Channels, Continued

FTA installation holes

Figure 8-12 illustrates the locations of the FTA mounting holes on the FTA Mounting Channel and the holes used to install the FTA Mounting Channel.

Figure 8-12 Vertical FTA Mounting Channel Installation Holes

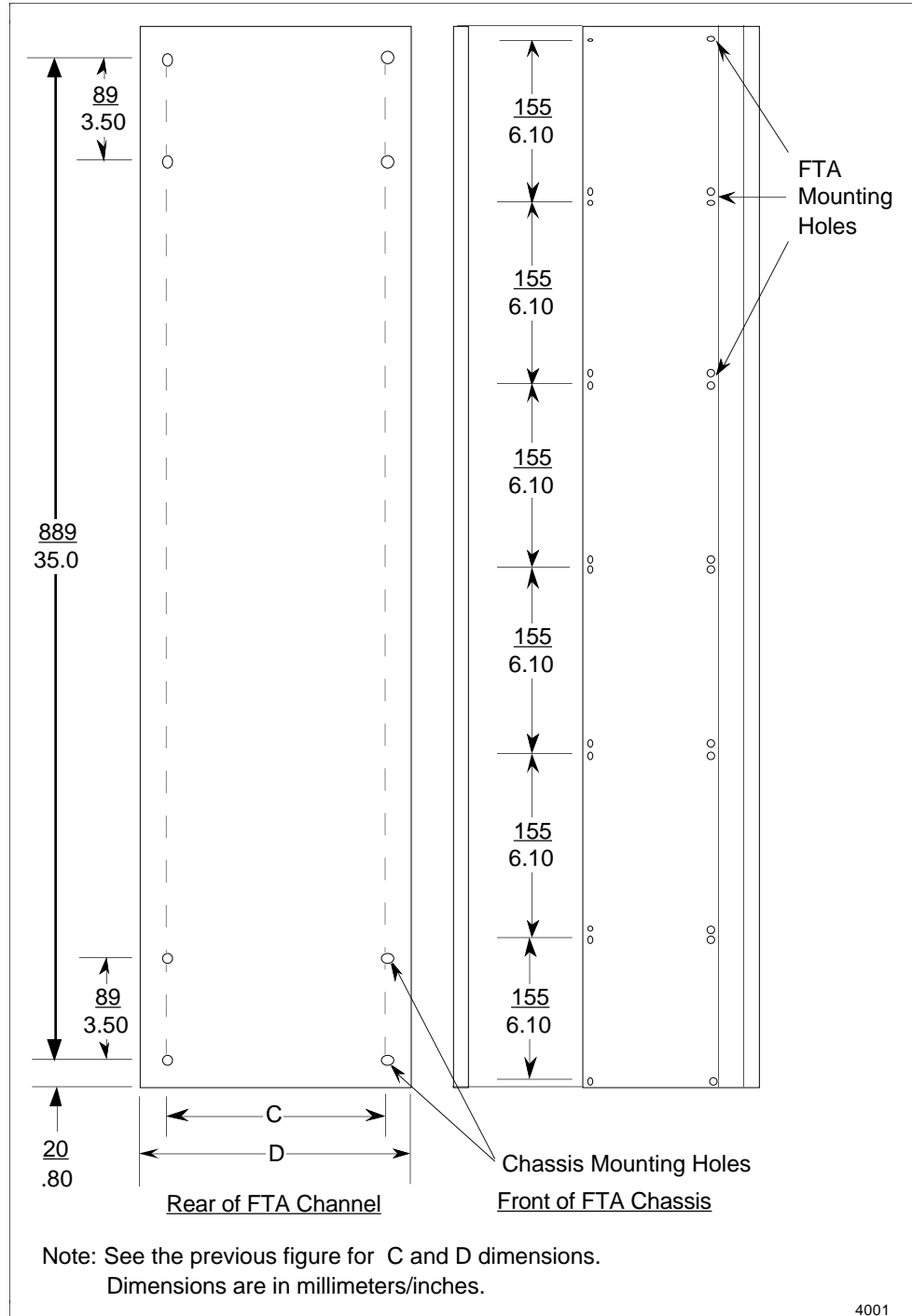

8.5.2 Horizontal FTA Mounting Channel

Overview

Galvanically Isolated FTAs are mounted on horizontal FTA Mounting Channels in the cabinet. The FTA Mounting Channels have two channels (troughs), upper and lower. Field wiring enters the lower channel from the right side of the cabinet and connects to the FTAs. The cables connecting the FTAs to their associated IOP(s), Power Distribution Assemblies, and Marshalling Panels, if present, are routed in the upper channel of the FTA Mounting Channel from the left side of the cabinet.

Single access FTA Mounting Channel installation

Up to three of the 62-centimeter (24.4-inch) long horizontal FTA Mounting Channels can be installed below the Power System in a single-access cabinet. A gap of approximately 22.9 centimeters (9 inches), the approximate width of a horizontal FTA Mounting Channel, must be maintained between the FTA Mounting Channels and the Power System.

Continued on next page

8.5.2 Horizontal FTA Mounting Channel, *Continued*

Dual Access FTA Mounting Channel installation

In the dual-access cabinet, up to eight FTA Mounting Channels can be installed on one side of a cabinet as shown in Figure 8-13.

Figure 8-13 Horizontal FTA Mounting Channel Cabinet Layout

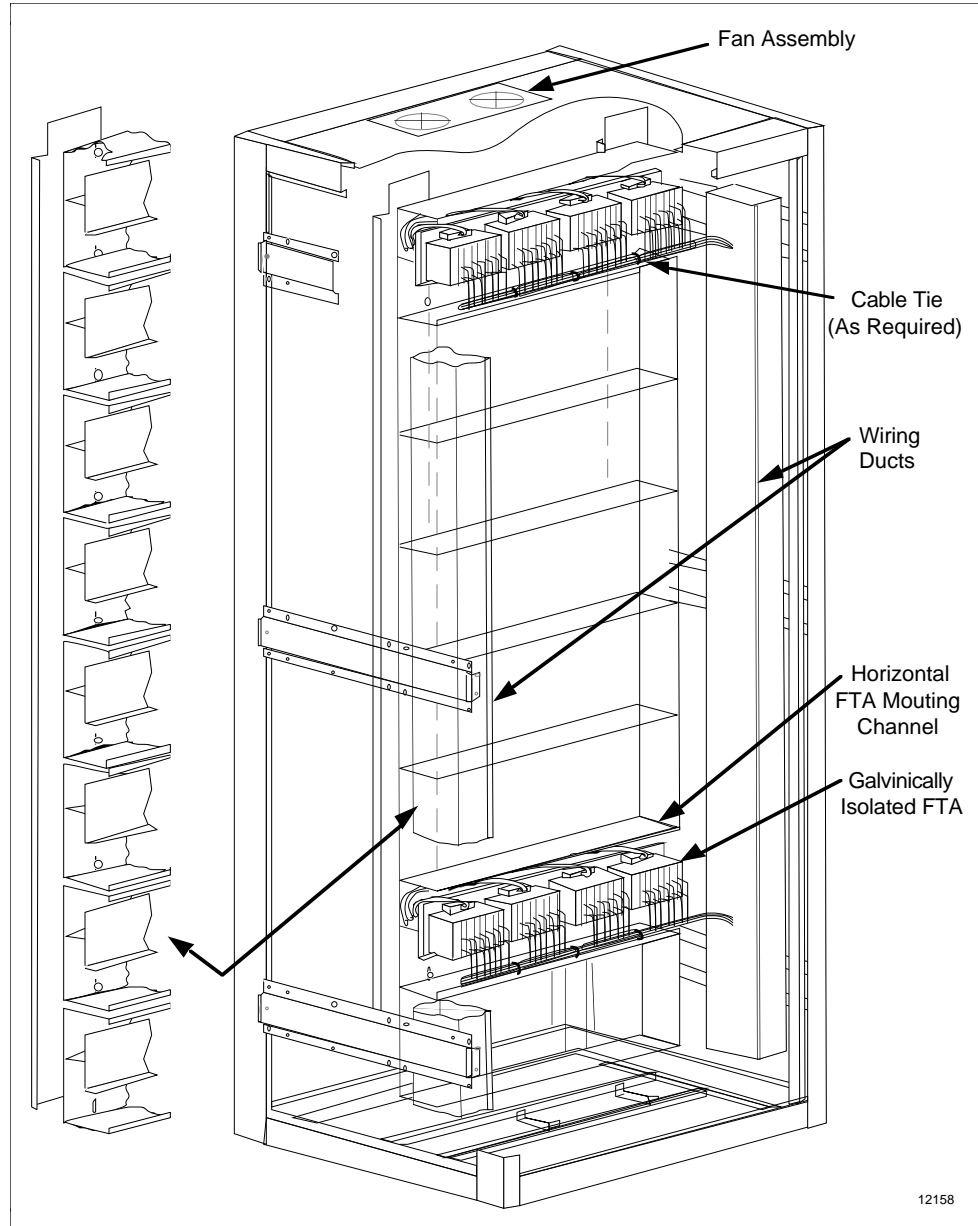

Continued on next page

8.5.2 Horizontal FTA Mounting Channel, Continued

FTA Mounting Channel widths

Horizontal FTA Mounting Channels are available in a single width.

22.2 cm (8.75 in.) W x 10.8 cm (4.25 in.) D x 62.0 cm (24.4 in.) L

Figure 8-14 illustrates the FTA Mounting Channel dimensions.

Figure 8-14 Horizontal FTA Mounting Channel Dimensions

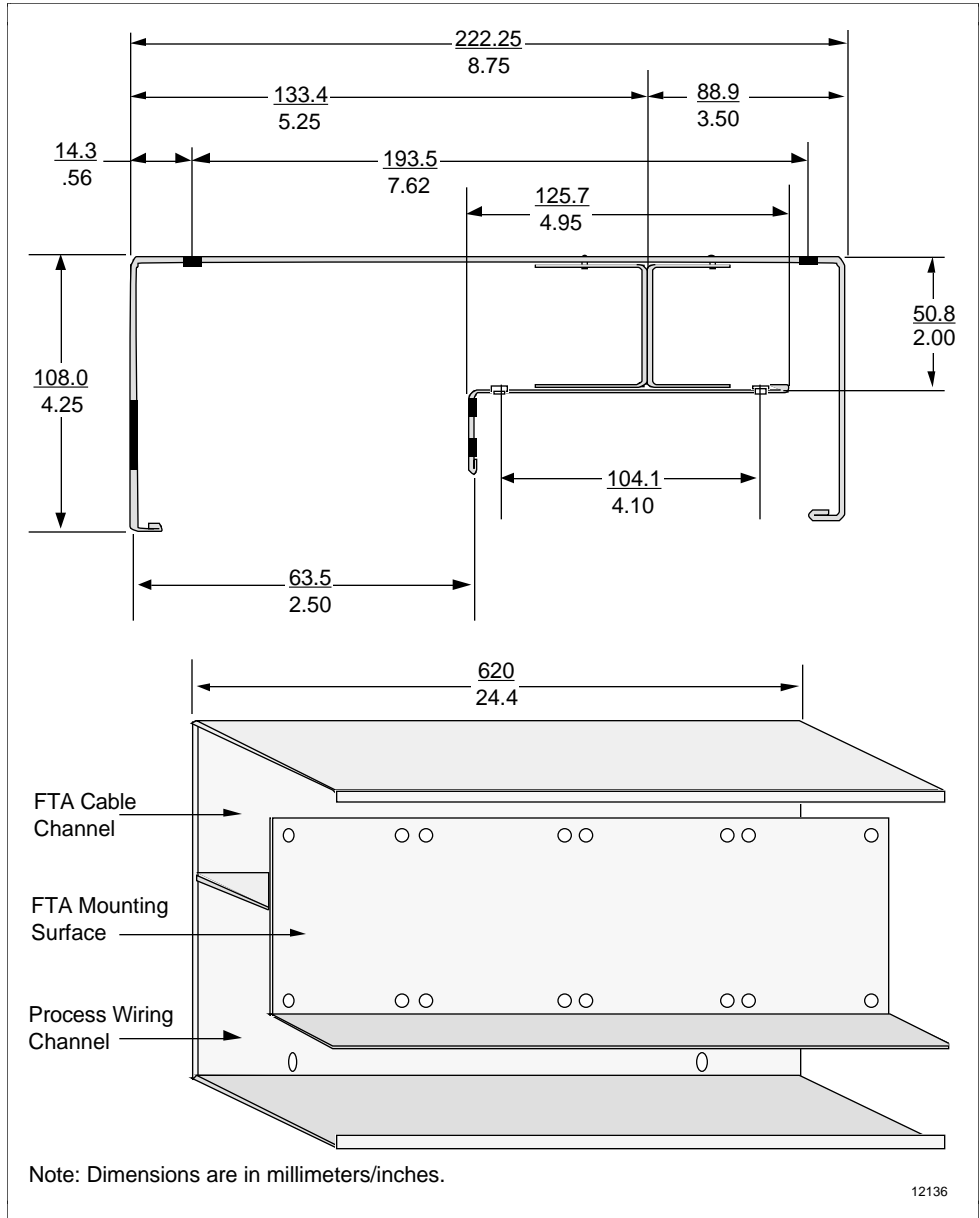

Continued on next page

8.5.2 Horizontal FTA Mounting Channel, Continued

Horizontal FTA Mounting Channel installation holes

Figure 8-15 illustrates the locations of the FTA mounting holes on the FTA Mounting Channel and the holes used to install the FTA Mounting Channel in the cabinet.

Figure 8-15 Horizontal FTA Mounting Channel Installation Holes

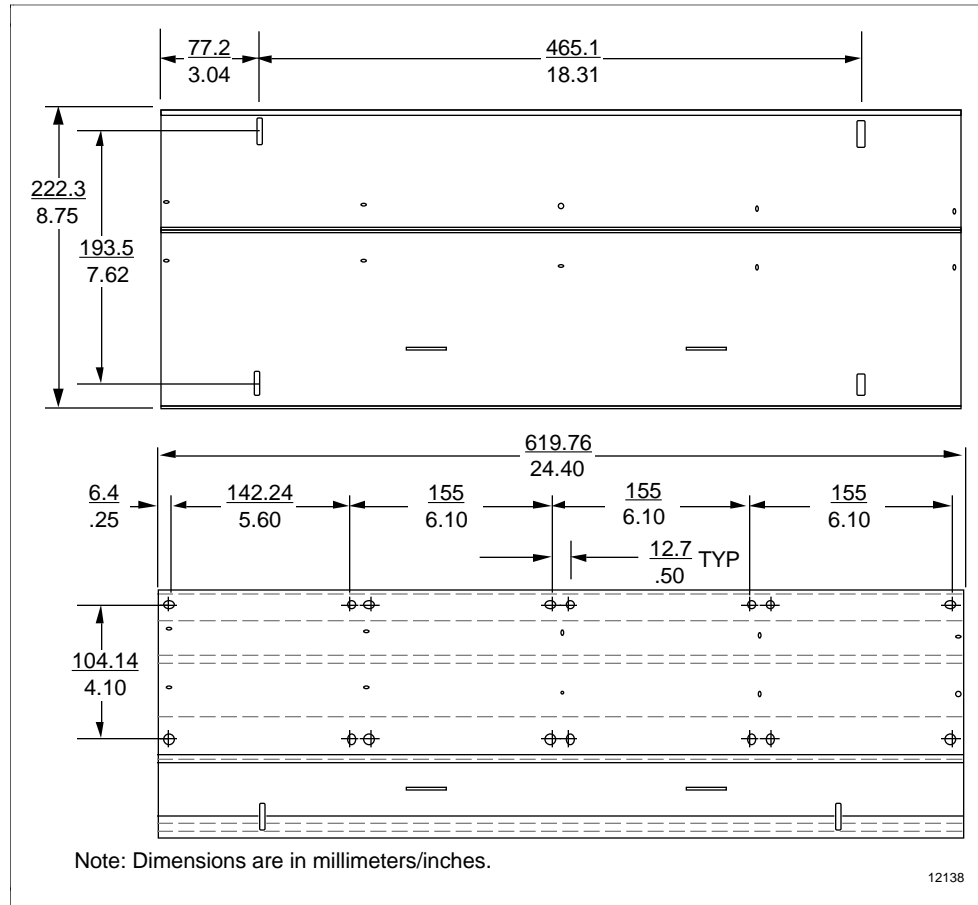

8.6 Cabinet Floor Planning

Floor template

Figure 8-16 is a floor template that will help you plan your facility layout when installing Process Manager or Advanced Process Manager cabinets.

Figure 8-16 Cabinet Floor Planning Template

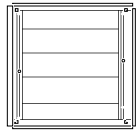

Single Dual Access Cabinet

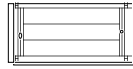

Single Single Access Cabinet

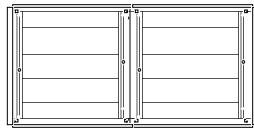

Dual Dual Access Cabinet Complex

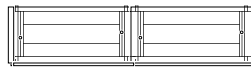

Dual Single Access Cabinet Complex

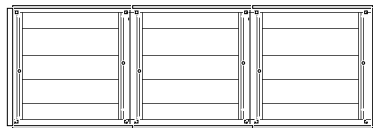

Triple Dual Access Cabinet Complex

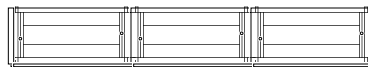

Triple Single Access Cabinet Complex

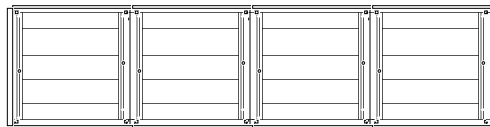

Quad Dual Access Cabinet Complex

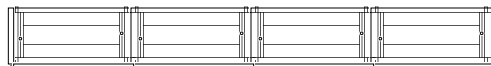

Quad Single Access Cabinet Complex

Note:

1. Cabinet scale is 1/4 inch = 1 foot.
2. A dual access cabinet is approximately 30 inches by 30 inches. The side and door panels add 1.5 inches to each cabinet dimension. When cabinets are complexed, 1.5 inches is added to the total complex dimensions.
3. A single access cabinet is approximately 30 inches wide and 21 inches deep. The side panels and the single door panel add 3/4 inch to the cabinet depth and 1.5 inches to the cabinet width. When cabinets are complexed, 3/4 inch is added to the complex depth and 1.5 inches is added to the total complex width.

2868

Section 9 – Model MU-CBSX01/MU-CBDX01 Cabinets

9.1 Overview

Section contents The topics covered in this section are:

	Topic	See Page
9.1	Overview.....	159
9.2	Cabinet Description	163
9.3	Card File and Power System Configurations	167
9.4	Card File and Power System Description	169
9.5	FTA Mounting Channel Descriptions.....	171
9.5.1	Vertical FTA Mounting Channels.....	172
9.5.2	Horizontal FTA Mounting Channel	176
9.6	Cabinet Floor Planning.....	180

Introduction The Process Manager or Advanced Process Manager model MU-CBSX01 and MU-CBDX01 cabinets provide single and dual access, respectively. Access is defined as having a single front door entry or dual front and rear door entry. The model MU-CBSX01 and MU-CBDX01 cabinets are also referred to as Rittal cabinets because Rittal is the manufacturer.

CE Compliant The model MU-CBSX01 and MU-CBDX01 cabinets are CE Compliant.

Continued on next page

9.1 Overview, Continued

Single access cabinet

The single-access cabinet has one equipment entry point and that is in the front of the cabinet through a single door. The Process Manager and Advanced Process Manager card files, Power System, and the FTA Mounting Channels with FTAs mounted are installed inside the single-access door. The cabinet side panels can be removed for access. Figure 9-1 is an illustration of a single-access cabinet.

Figure 9-1 Single-Access Cabinet

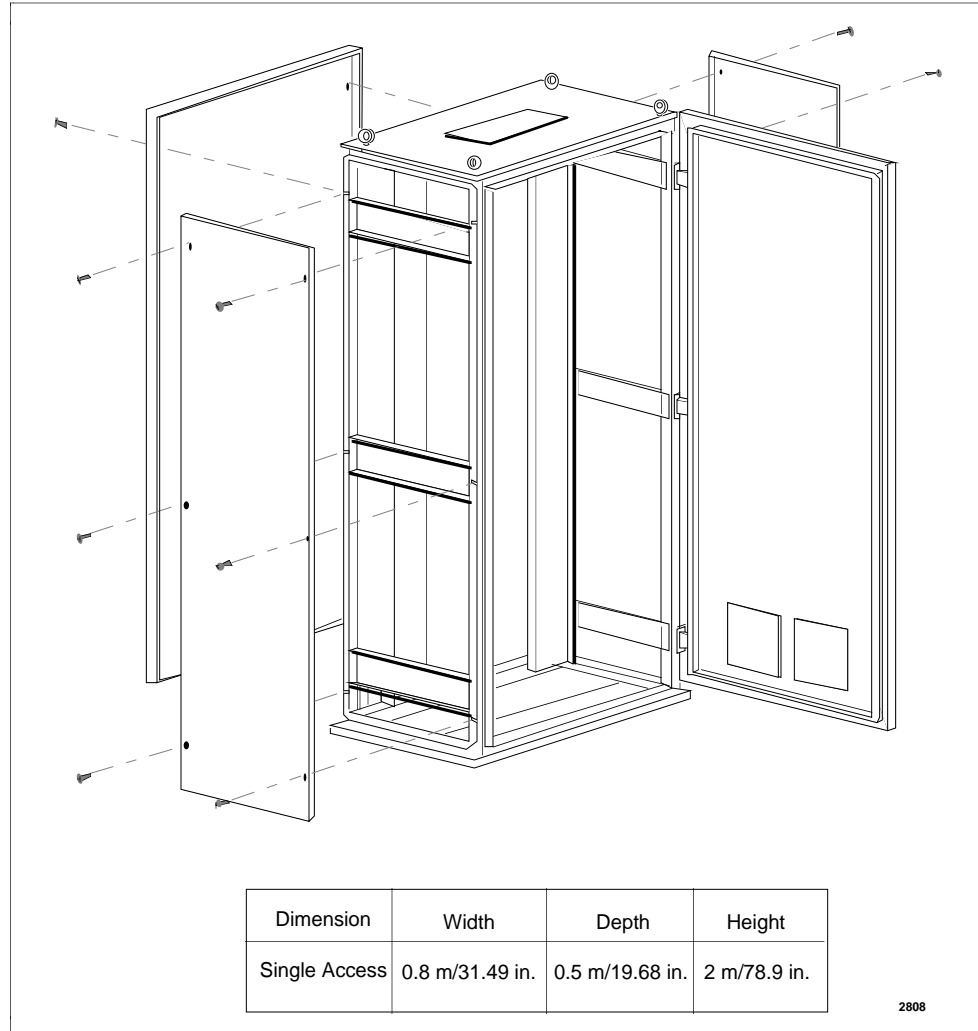

Continued on next page

9.1 Overview, Continued

Dual access cabinet

The dual-access cabinet has two equipment entry points. The Process Manager and Advanced Process Manager card files and the Power System are mounted inside the front access door. The FTA Mounting Channels are normally installed inside the rear door. The cabinet side panels can be removed for access. Figure 9-2 is an illustration of a dual-access cabinet.

Figure 9-2 Dual-Access Cabinet

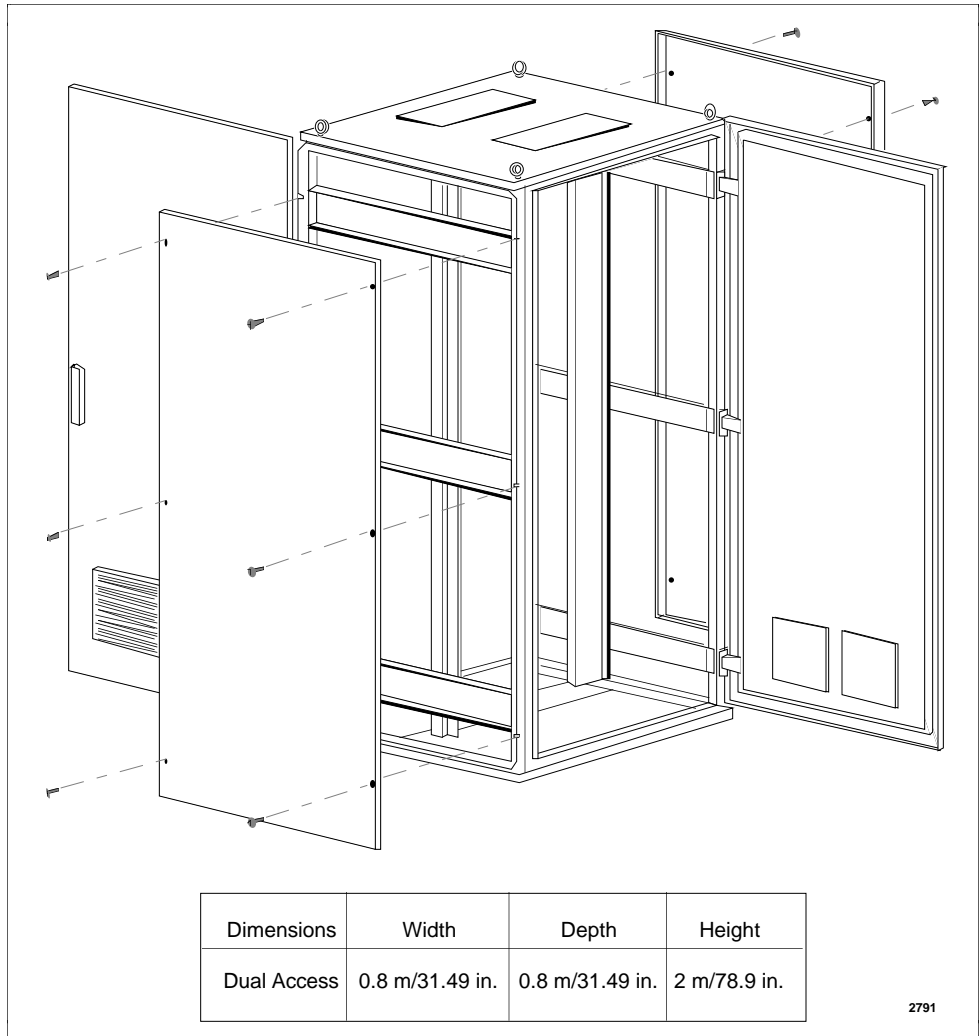

Continued on next page

9.1 Overview, Continued

CE Compliance

CE Compliance versions of the cabinet are identified by the abundance of grounding straps inside the cabinet. All panels and doors are grounded to the cabinet frame by the straps. Figures 9-3 and 9-4 illustrate the mechanisms used to ground the cabinet panels and doors.

Figure 9-3 Cabinet Base Panel Grounding Procedure

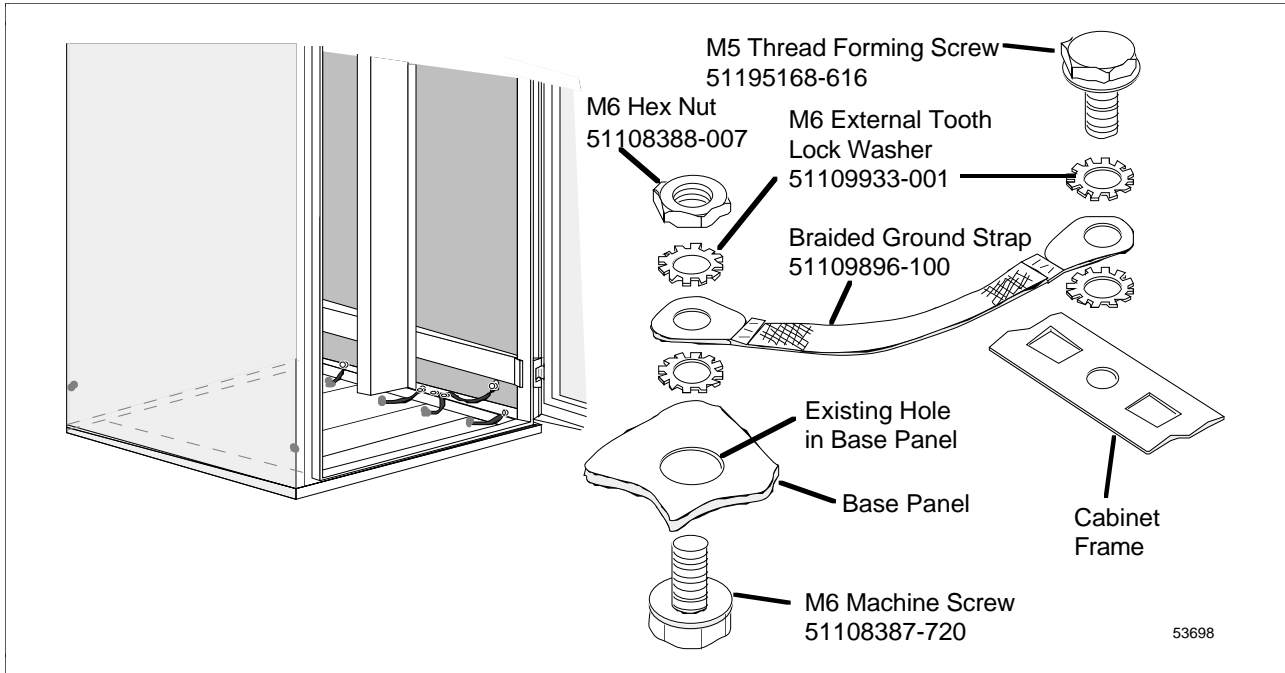
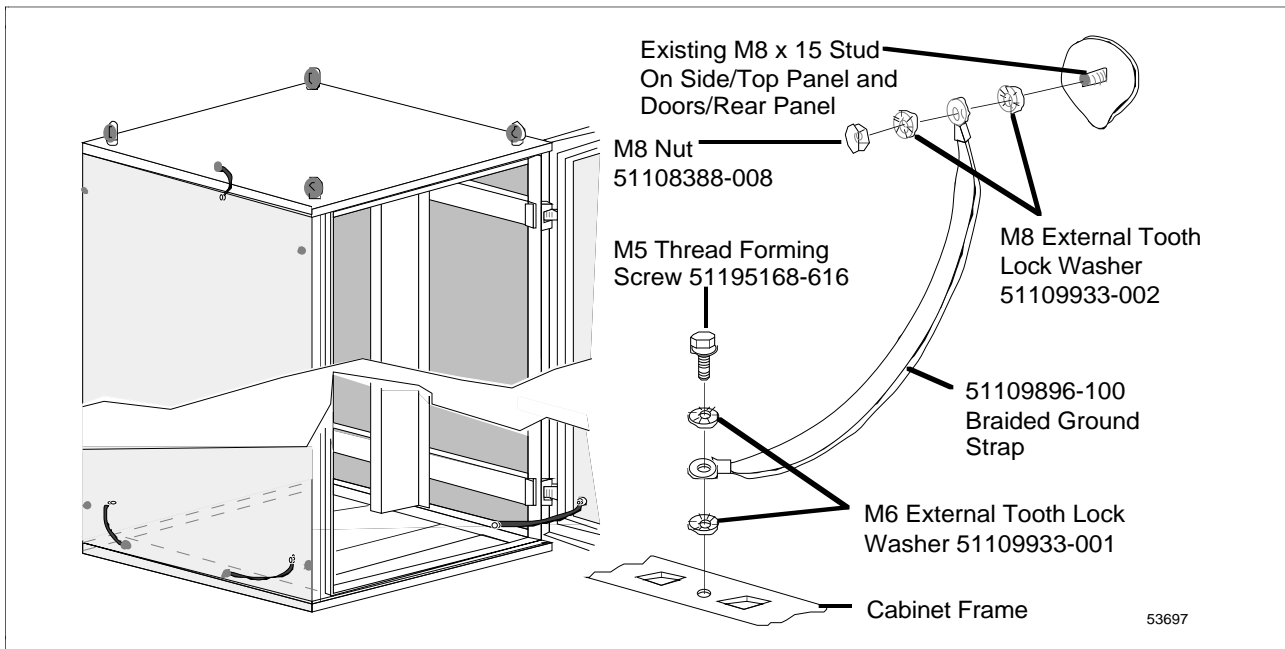

Figure 9-4 Cabinet Panel and Door Grounding Procedure



9.2 Cabinet Description

Cabinet dimensions

The single-access cabinet, with the front door, side and rear panels installed, has the following exterior dimensions.

0.8 meters wide x 0.5 meters deep x 2 meters high
(31.5 inches x 19.7 inches x 78.9 inches)

The dual-access cabinet, with the front and rear doors, and side panels installed, has the following exterior dimensions.

0.8 meters wide x 0.55 meters deep x 2.1 meters high
(31.5 inches x 31.5 inches x 78.9 inches)

Top and bottom entry

Both cabinets are NEMA 1 rated and support top and bottom entry for process control wiring. Top entry requires removal of the top panel(s), and/or associated fan assemblies, before entry holes can be punched in the panel. Honeywell will prepunch the holes if specified when ordering the cabinet. Figures 9-5 and 9-6 are illustrations of the bottom cable entry slots for the single and dual access cabinets, respectively.

Single access cabinet bottom entry

Figure 9-5 is an illustration of the bottom cable entry for the single-access cabinet.

Figure 9-5 Single-Access Cabinet Bottom Cable Entry

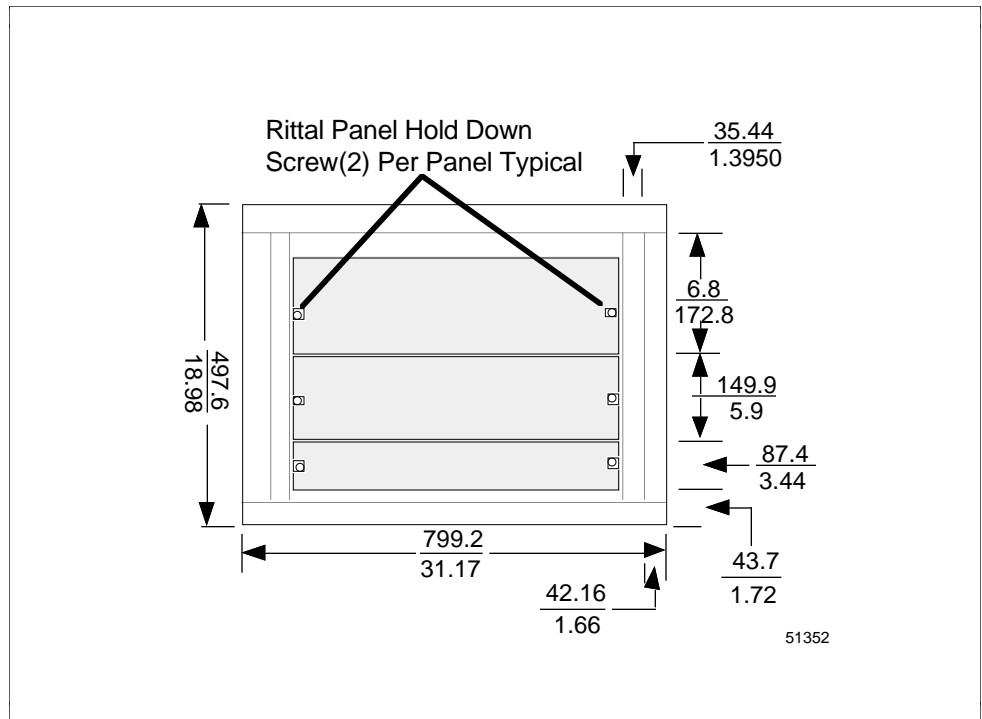

Continued on next page

9.2 Cabinet Description, Continued

Dual access cabinet bottom entry

Figure 9-6 is an illustration of the bottom cable entry for the dual-access cabinet.

Figure 9-6 Dual-Access Cabinet Bottom Cable Entry

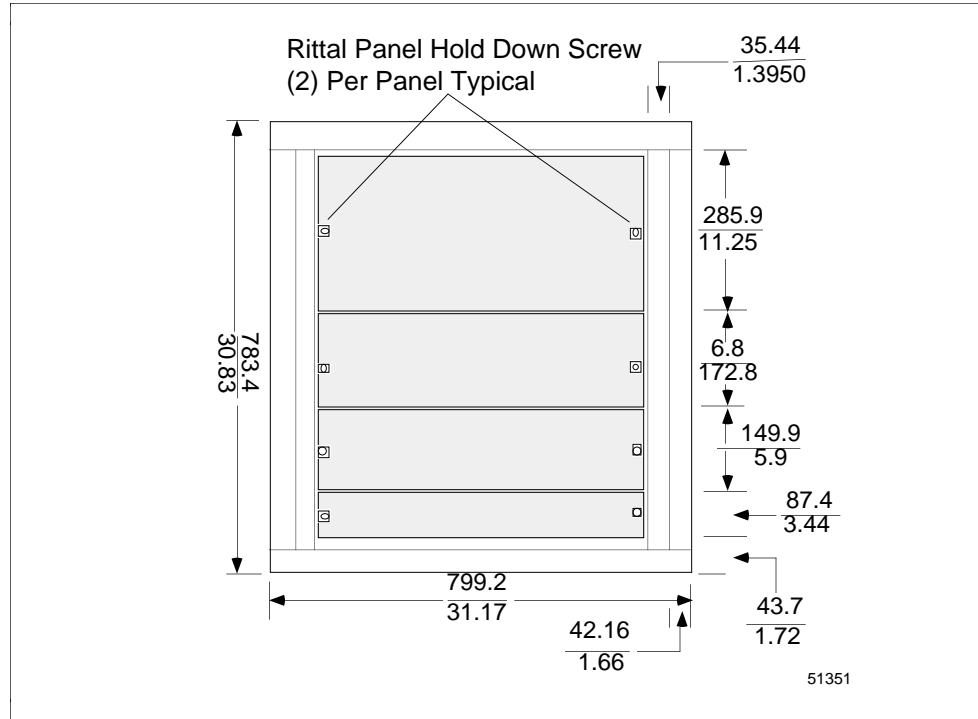

Continued on next page

9.2 Cabinet Description, Continued

Independent cabinet entry

A single-access cabinet has only one entry side. The dual-access cabinet has two independent entry sides. Card files and the Power System, or FTA Mounting Channels can be installed in either side of the cabinet without being constrained by the equipment installed in the other side of the cabinet.

The cabinet can be ordered with doors hinged on either the left or right side.

Cabinet complexing

A maximum of four cabinets can be complexed together without intervening side panels by a complexing kit, Honeywell part number 51109524-200 (single-access cabinet) or 51109524-100 (dual-access cabinet).

NEMA 12

NEMA 12 rated cabinets can be ordered from Honeywell.

Cabinet cooling

Cabinet cooling is accomplished by the use of one or more fan assemblies that are mounted over appropriate cutouts in the cabinet top. Use of a fan assembly is mandatory for a cabinet entry side containing card files or a Power System. Because of power dissipation, the cabinet configuration determines if a fan assembly is required for a cabinet entry side containing Field Termination Assemblies (FTAs). A fan assembly is mandatory when Galvanically Isolated FTAs are installed. Fan assemblies are available for voltages and frequencies noted below.

- Cabinet Fan Assembly (240 Vac, 50/60 Hz)
- Cabinet Fan Assembly (120 Vac, 50/60 Hz)

A blank plate is available to cover the hole(s) in the top of the cabinet in the event a fan assembly is not needed. The fan opening cabinet-top cover plate is Honeywell part number 51304098-200.

Continued on next page

9.2 Cabinet Description, Continued

Cabinet infrastructure

As shown in Figure 9-7, the cabinet is provided with an internal structure (“infrastructure”) that is capable of accepting card file assemblies, Power Systems, and FTA Mounting Channels. When installing FTAs, FTA Mounting Channels must be specified as discussed in subsection 9.5.

Figure 9-7 Cabinet Interior Dimensions

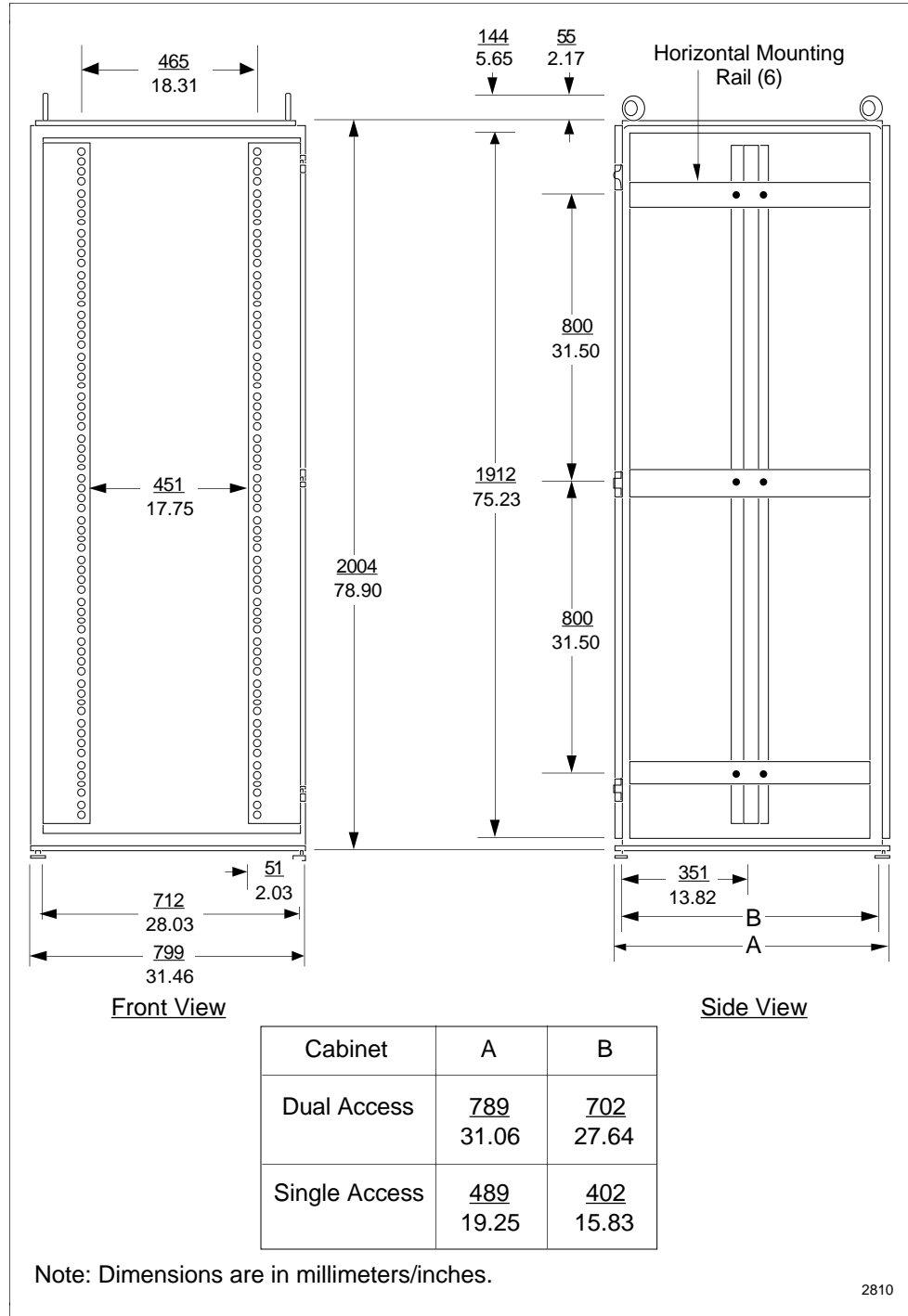

9.3 Card File and Power System Configurations

Cabinet layout

The Process Manager and Advanced Process Manager card files, Power System and FTA Mounting Channels install in the single- and dual-access cabinets as shown in Figures 9-8 and 9-9, respectively.

Single access cabinet equipment layout

Figure 9-8 illustrates the equipment layout in a single-access cabinet.

Figure 9-8 Typical Single-Access Cabinet Assembly Layout

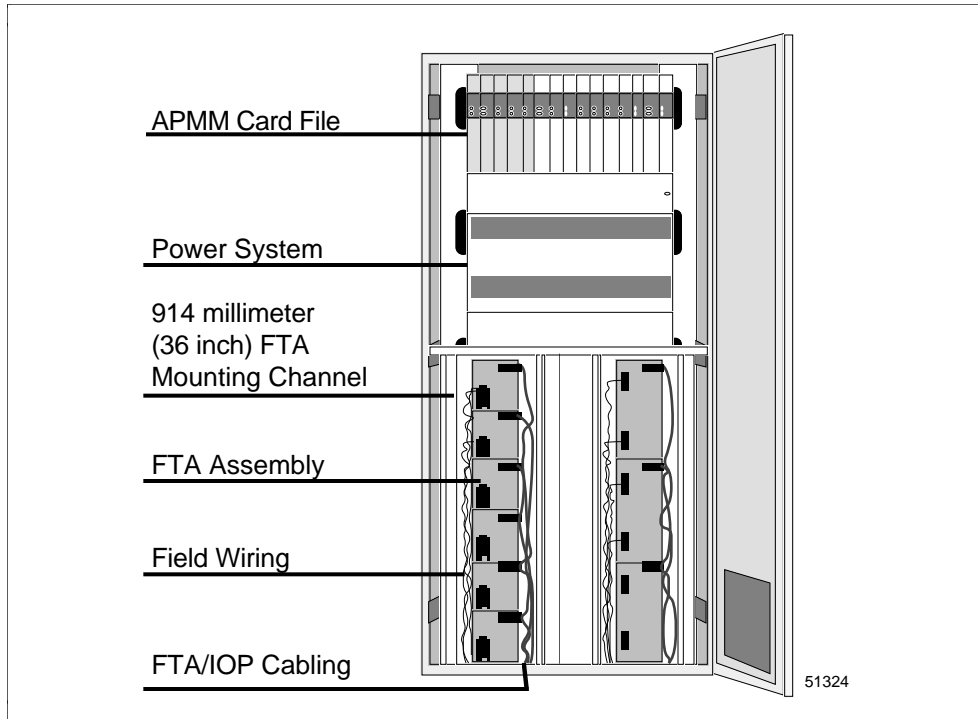

Continued on next page

9.3 Card File and Power System Configurations, Continued

Dual access cabinet equipment layout

Figure 9-9 illustrates the equipment layout in a dual-access cabinet.

Figure 9-9 Typical Dual-Access Cabinet Assembly Layout

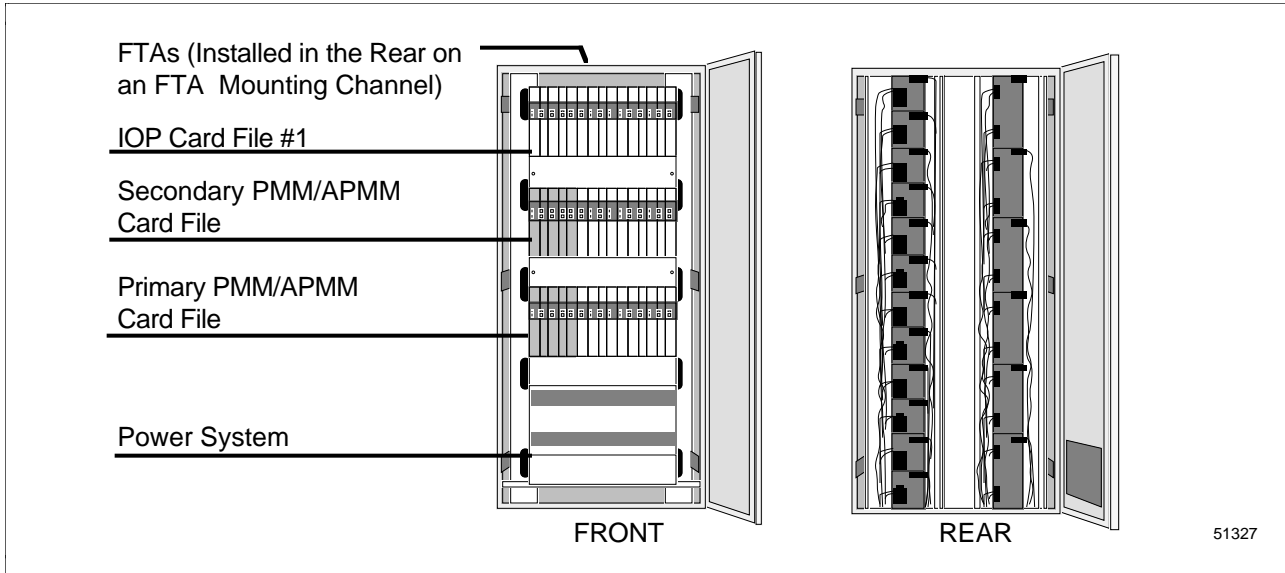

9.4 Card File and Power System Descriptions

Card file dimensions

All three card file assemblies, single PMM/APMM, redundant PMM/APMM, and IOP are the same size as illustrated in Figure 9-10 and install on a 19" RETMA mounting infrastructure.

Figure 9-10 Card File Installation Dimensions

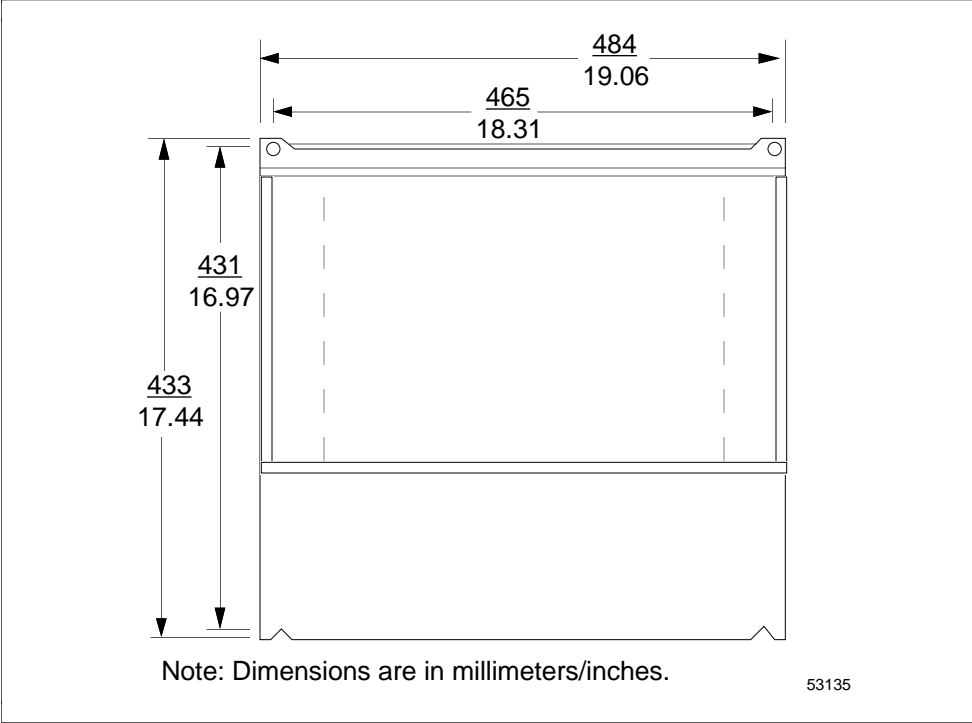

Continued on next page

9.4 Card File and Power System Descriptions, Continued

Power System dimensions

The Power System dimensions are shown in Figure 9-11 and it also installs on a 19" RETMA mounting infrastructure.

Figure 9-11 Power System Installation Dimensions

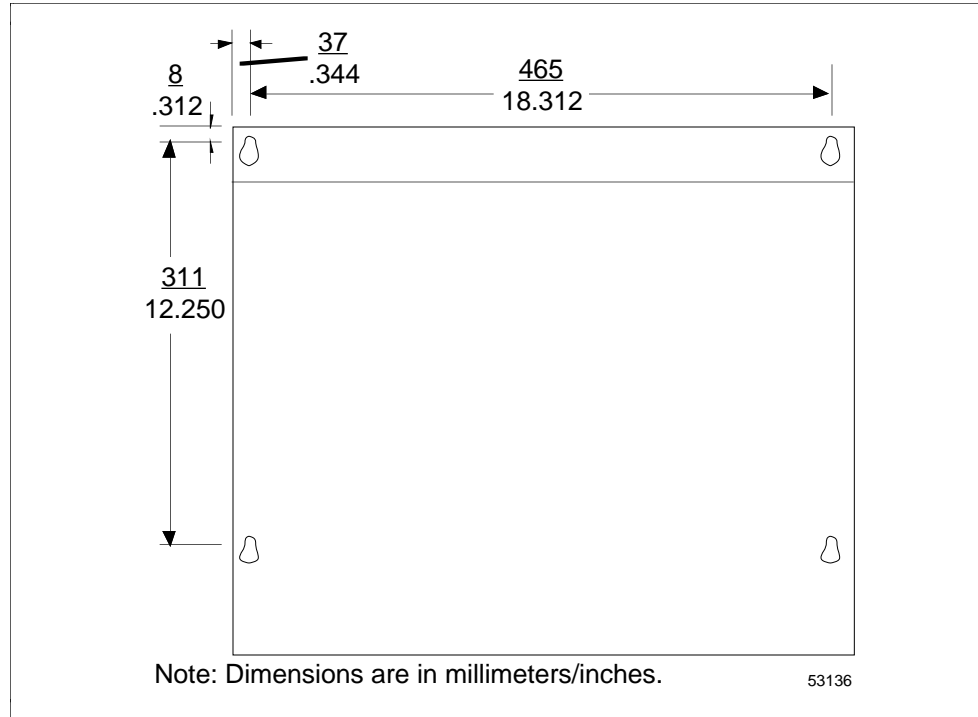

9.5 FTA Mounting Channel Descriptions

Introduction

Field Termination Assemblies (FTAs) are produced in three standard sizes that are dependent on the FTA type and circuit requirements.

Size A 15.20 cm (6.0 in.) x 12.0 cm (4.75 in.)

Size B 30.48 cm (12.1 in.) x 12.0 cm (4.75 in.)

Size C 46.22 cm (18.2 in.) x 12.0 cm (4.75 in.)

They mount on FTA Mounting Channels that are attached to the cabinet's infrastructure.

Three styles of FTA Mounting Channels are available:

- Wide vertical
- Narrow vertical
- Horizontal

Selection is based on whether standard or Galvanically Isolated FTAs are installed in the cabinet.

The FTA Mounting Channels used to mount standard FTAs are vertically oriented in the cabinet, and the FTA Mounting Channels used to mount Galvanically Isolated FTAs are horizontally oriented in the cabinet.

9.5.1 Vertical FTA Mounting Channels

Overview

Standard FTAs are mounted on vertically oriented FTA Mounting Channels in the cabinet. The vertical FTA Mounting Channels have two channels (troughs), right and left. Field wiring enters the left channel and connects to the FTAs. The cables connecting the FTAs to their associated IOP(s) or Power Distribution Assemblies are routed in the right channel of the FTA Mounting Channel.

FTA Mounting Channel configurations

The vertical FTA Mounting Channel length, approximately 93 centimeters (36 inches) is approximately half the height of the cabinet. The FTA Mounting Channels can be mounted adjacent to each other in this vertical area. The FTA mounting configurations will allow

- up to four narrow channels or
- up to three wide channels.

The FTA Mounting Channel configurations can be mounted adjacent to each other in the area below the Power System in a single-access cabinet as shown in Figure 9-8.

In the dual-access cabinet, one FTA Mounting Channel is normally installed above another, adjacently in pairs, as shown in Figure 9-9.

Continued on next page

9.5.1 Vertical FTA Mounting Channels, Continued

Vertical FTA Mounting Channel configurations

Figure 9-12 illustrates four typical vertical FTA Mounting Channel cabinet configurations.

Figure 9-12 FTA Mounting Channel Configurations

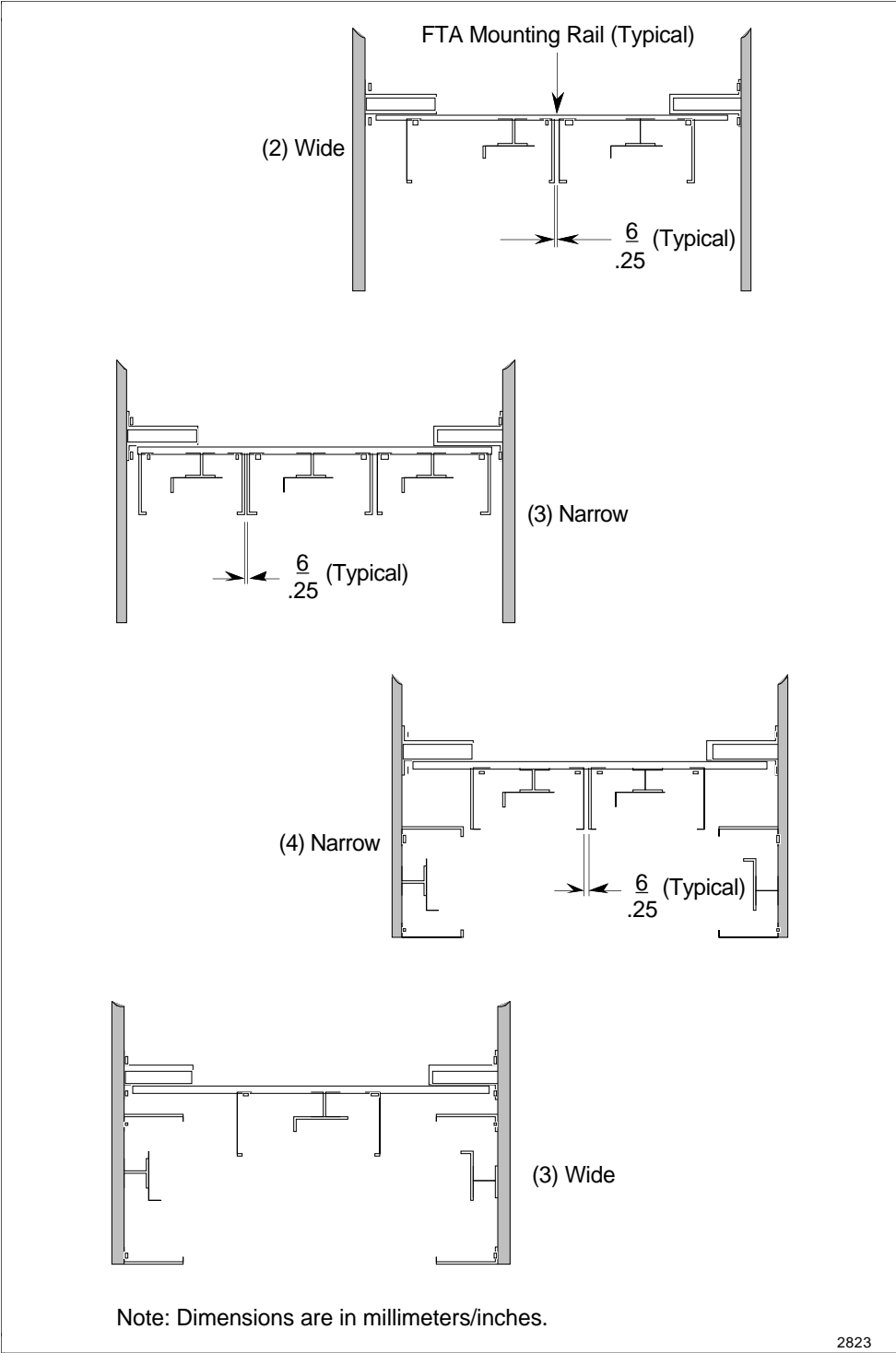

Continued on next page

9.5.1 Vertical FTA Mounting Channels, Continued

Vertical FTA Mounting Channel widths

Vertical FTA Mounting Channels are available in two widths:

Narrow 22.2 cm (8.75 in.) W x 10.8 cm (4.25 in.) D x 93 cm (36.6 in.) L
 Wide 27.3 cm (10.75 in.) W x 10.8 cm (4.25 in.) D x 93 cm (36.6 in.) L

Figure 9-13 illustrates the FTA Mounting Channel dimensions.

Figure 9-13 FTA Mounting Channel Dimensions

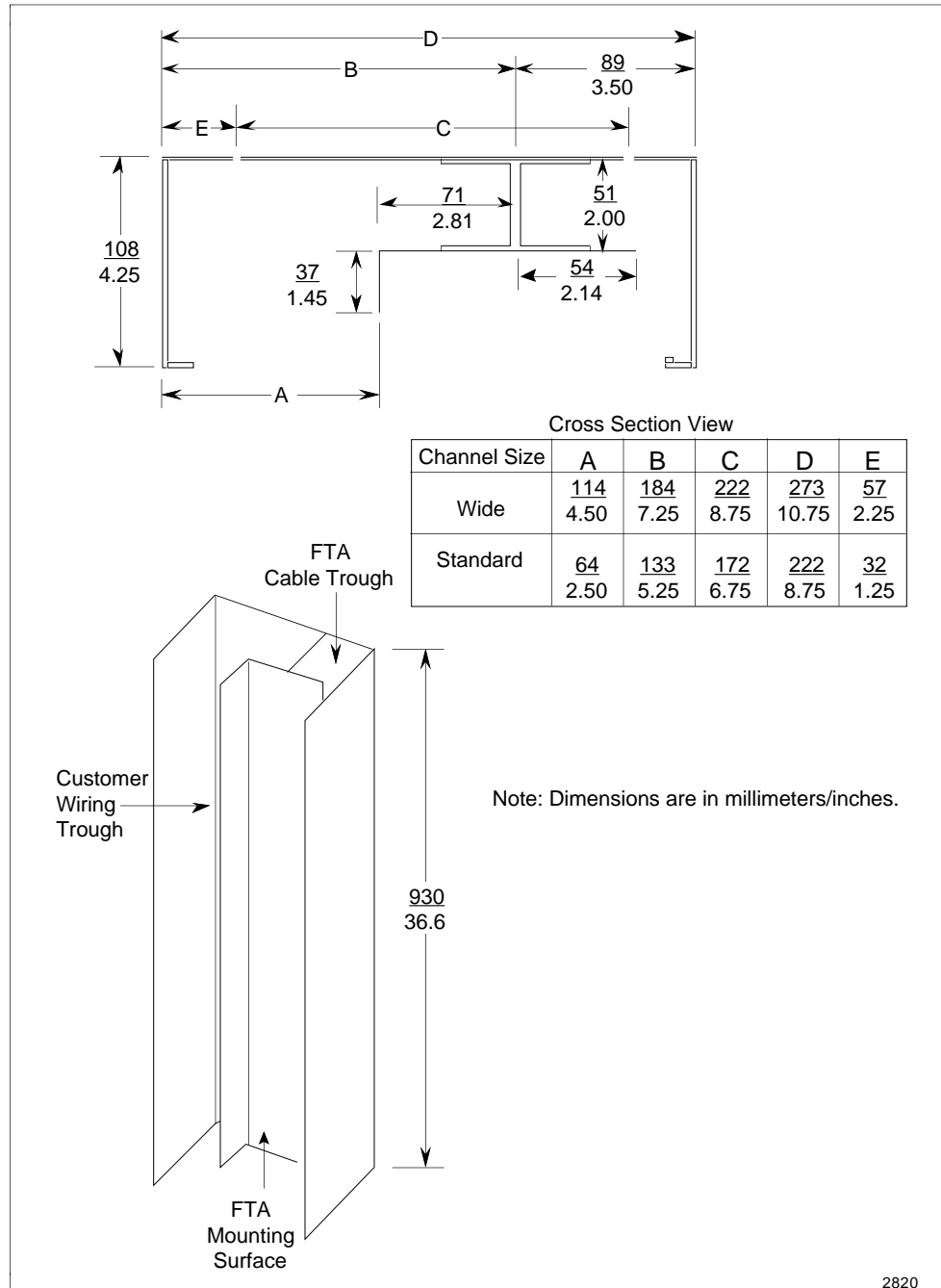

Continued on next page

9.5.1 Vertical FTA Mounting Channels, Continued

Vertical FTA Mounting Channel installation holes

Figure 9-14 illustrates the locations of the FTA mounting holes on the FTA Mounting Channel and the holes used to install the FTA Mounting Channel.

Figure 9-14 FTA Mounting Channel Mounting FTA Installation Holes

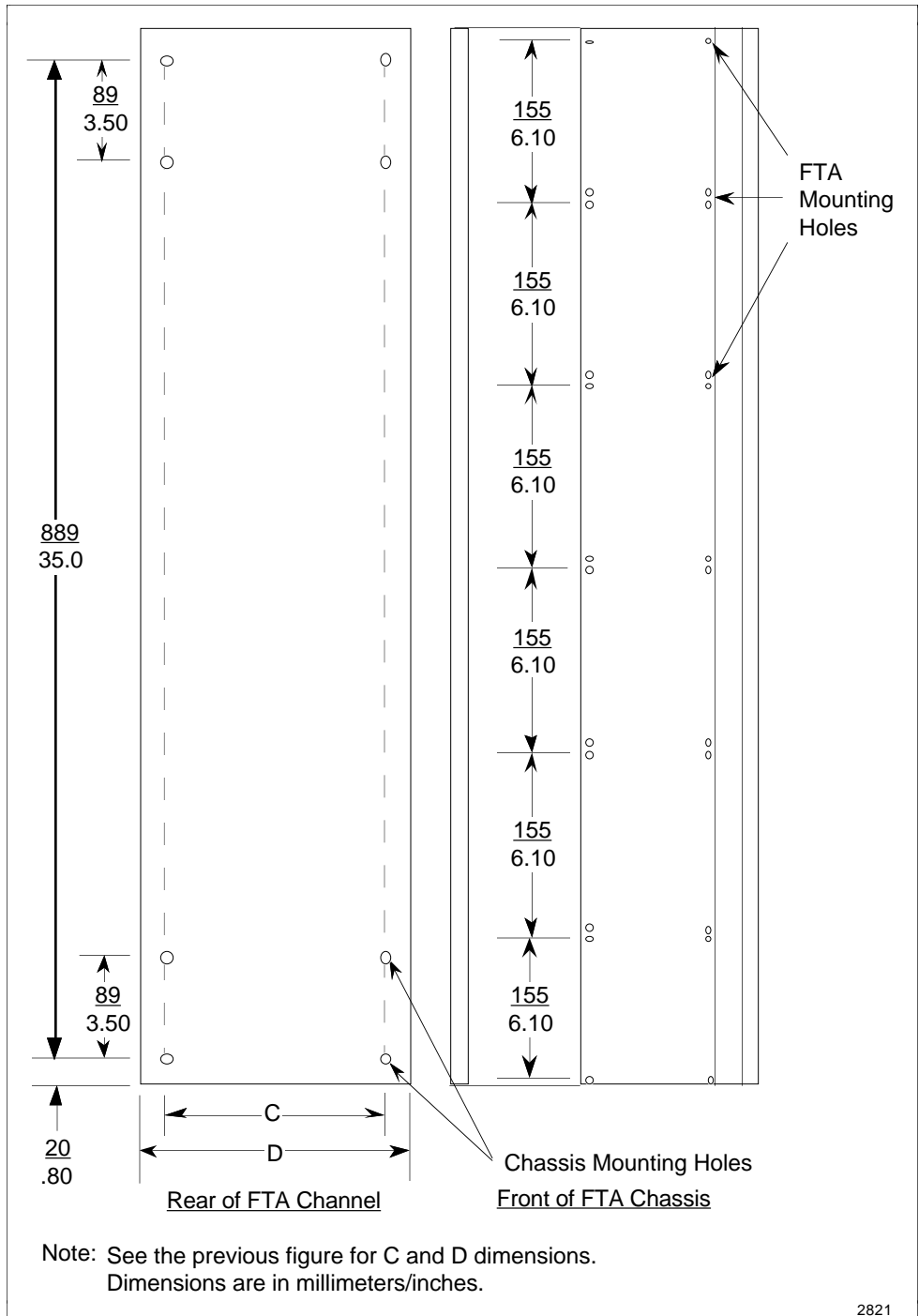

9.5.2 Horizontal FTA Mounting Channel

Overview

Galvanically Isolated FTAs are mounted on horizontal FTA Mounting Channels in the cabinet. The FTA Mounting Channels have two channels (troughs), upper and lower. Field wiring enters the lower channel from the right side of the cabinet and connects to the FTAs. The cables connecting the FTAs to their associated IOP(s), Power Distribution Assemblies, and Marshalling Panels, if present, are routed in the upper channel of the FTA Mounting Channel from the left side of the cabinet.

Single access FTA Mounting Channel installation

Up to three of the 62-centimeter (24.4-inch) long horizontal FTA Mounting Channels can be installed below the Power System in a single-access cabinet. A gap of approximately 22.9 centimeters (9 inches), the approximate width of a horizontal FTA Mounting Channel, must be maintained between the FTA Mounting Channels and the Power System.

Continued on next page

9.5.2 Horizontal FTA Mounting Channel, Continued

Dual access FTA Mounting Channel installation

In the dual-access cabinet, up to eight FTA Mounting Channels can be installed on one side of a cabinet as shown in Figure 9-15.

Figure 9-15 Horizontal FTA Mounting Channel Cabinet Layout

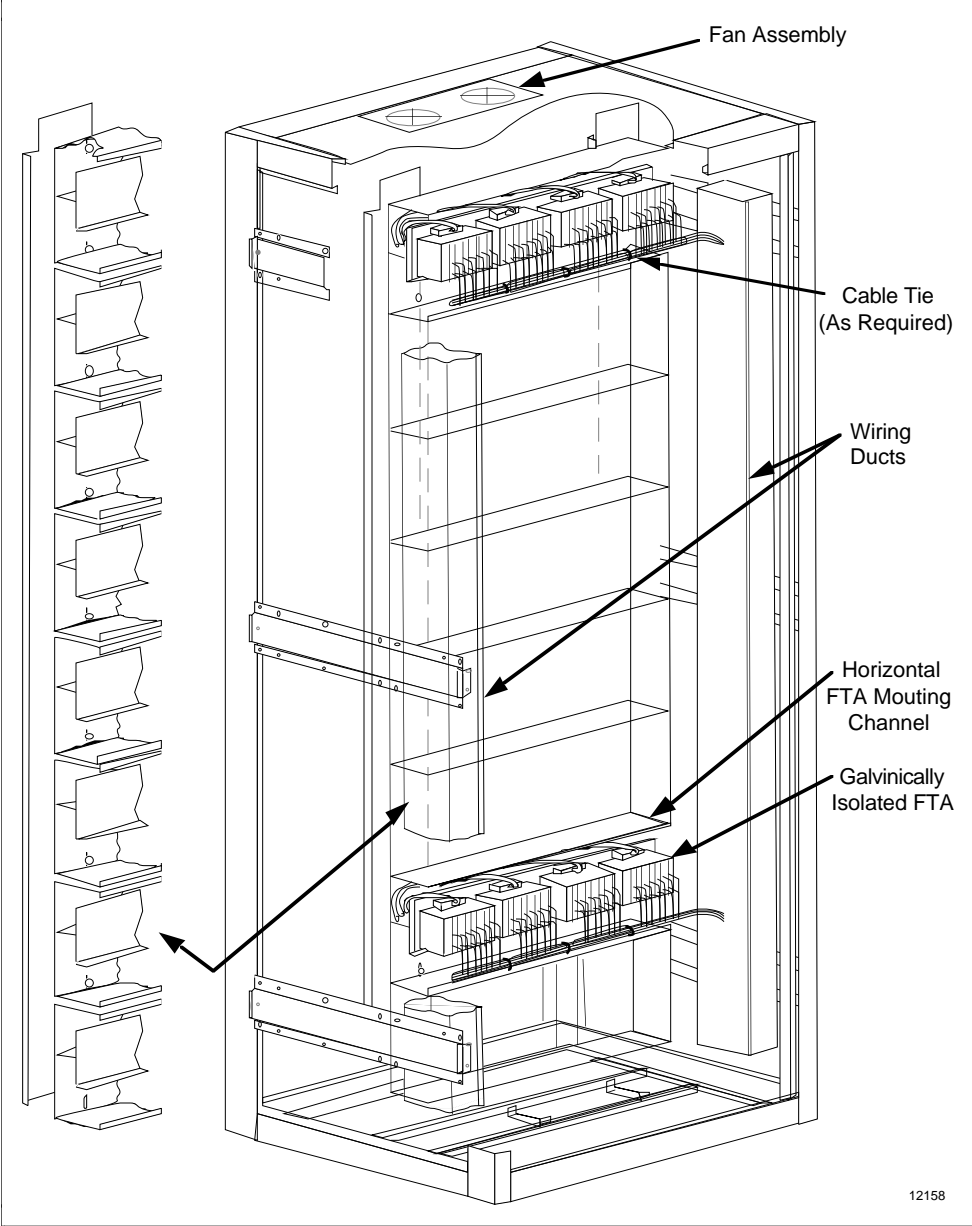

Continued on next page

9.5.2 Horizontal FTA Mounting Channel, Continued

FTA Mounting Channel widths

Horizontal FTA Mounting Channels are available in a single width.

22.2 cm (8.75 in.) W x 10.8 cm (4.25 in.) D x 62.0 cm (24.4 in.) L

Figure 9-16 illustrates the FTA Mounting Channel dimensions.

Figure 9-16 Horizontal FTA Mounting Channel Dimensions

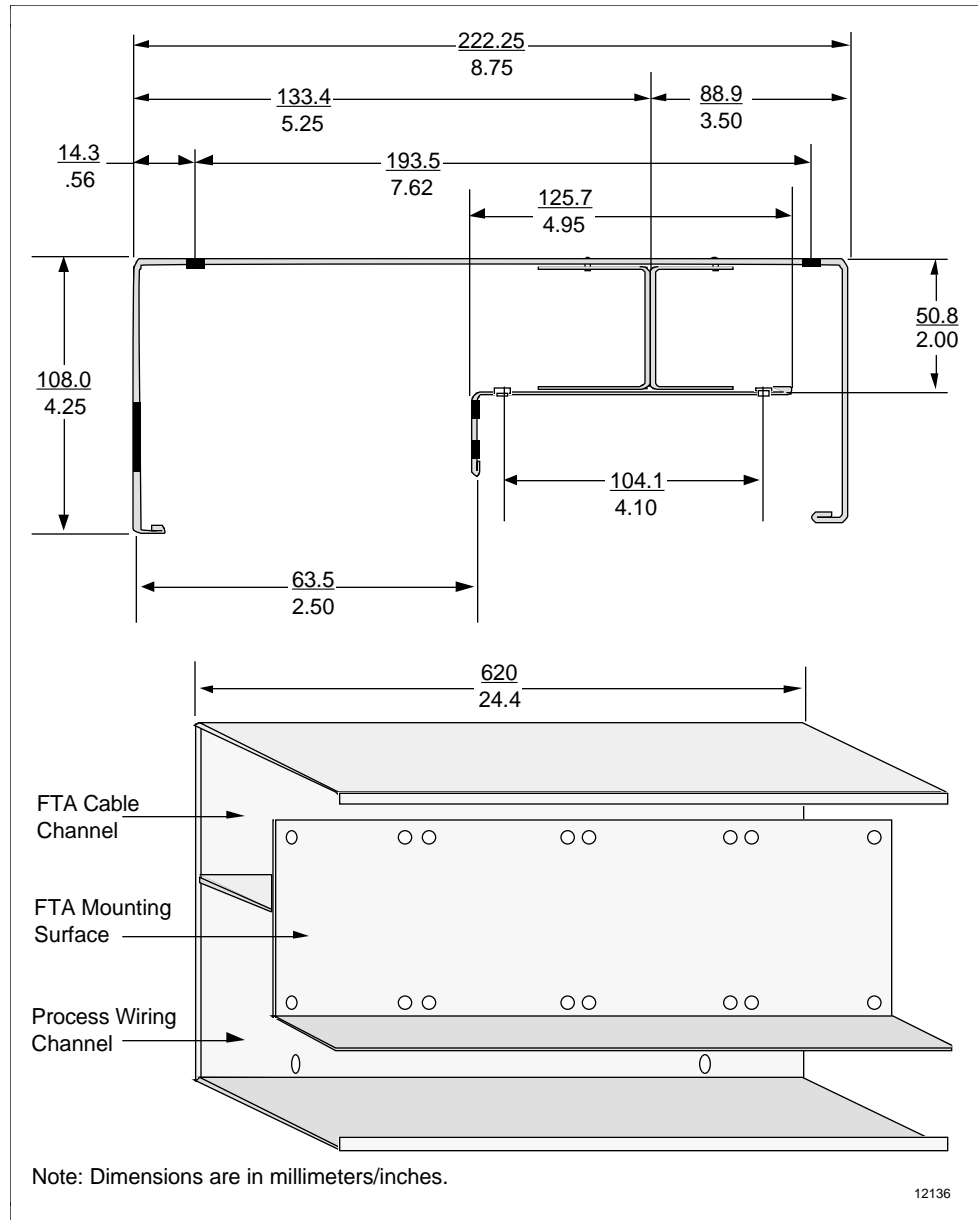

Continued on next page

9.5.2 Horizontal FTA Mounting Channel, Continued

Horizontal FTA Mounting Channel installation holes

Figure 9-17 illustrates the locations of the FTA mounting holes on the FTA Mounting Channel and the holes used to install the FTA Mounting Channel in the cabinet.

Figure 9-17 Horizontal FTA Mounting Channel Installation Holes

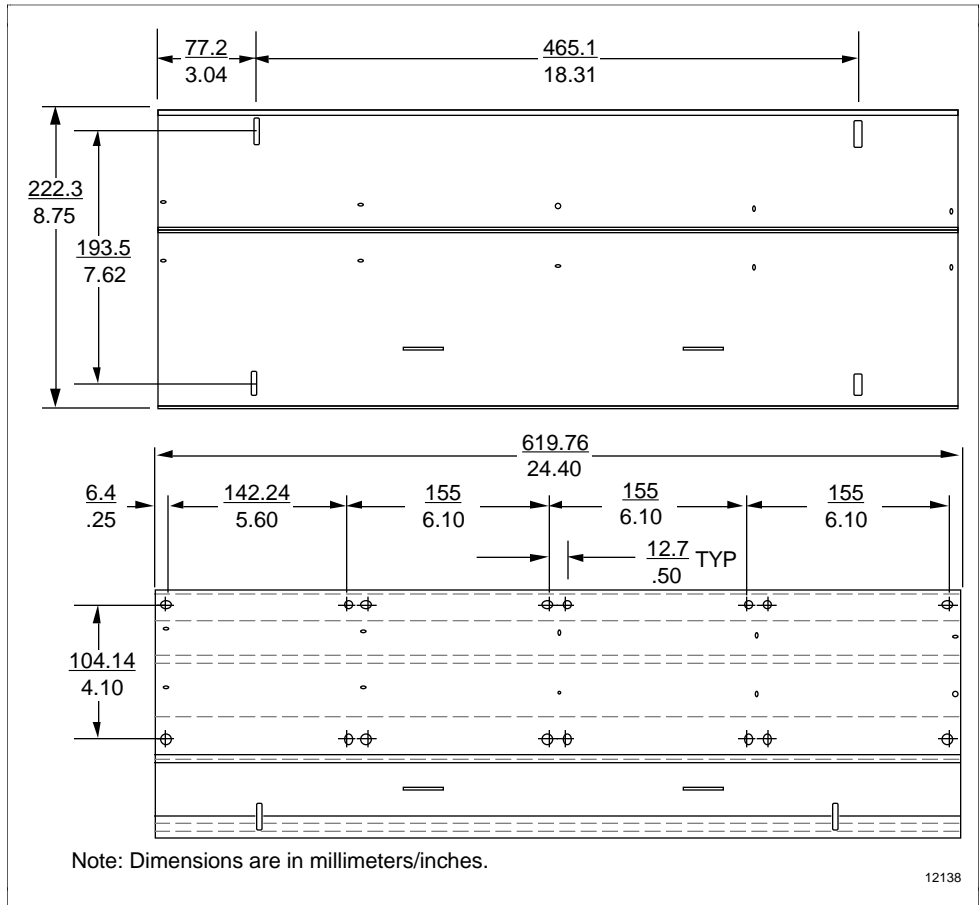

9.6 Cabinet Floor Planning

Floor template

Figure 9-18 is a floor template that will help you plan your facility layout when installing Process Manager or Advanced Process Manager cabinets.

Figure 9-18 Cabinet Floor Planning Template

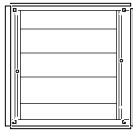

Single Dual Access Cabinet

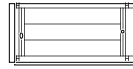

Single Single Access Cabinet

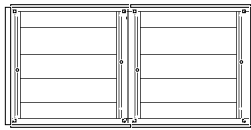

Dual Dual Access Cabinet Complex

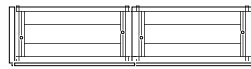

Dual Single Access Cabinet Complex

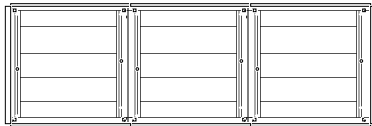

Triple Dual Access Cabinet Complex

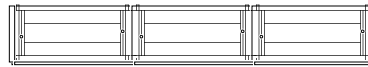

Triple Single Access Cabinet Complex

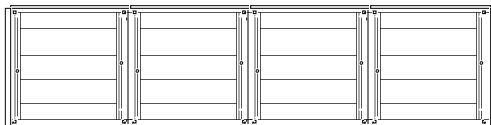

Quad Dual Access Cabinet Complex

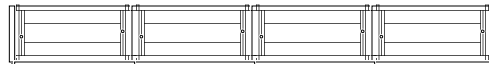

Quad Single Access Cabinet Complex

Note:

1. Cabinet scale is 1/4 inch = 1 foot.
2. A dual access cabinet is approximately 30 inches by 30 inches. The side and door panels add 1.5 inches to each cabinet dimension. When cabinets are complexed, 1.5 inches is added to the total complex dimensions.
3. A single access cabinet is approximately 30 inches wide and 21 inches deep. The side panels and the single door panel add 3/4 inch to the cabinet depth and 1.5 inches to the cabinet width. When cabinets are complexed, 3/4 inch is added to the complex depth and 1.5 inches is added to the total complex width.

2868

Section 10 – Redundancy Planning

10.1 Overview

Section contents The topics covered in this section are:

	Topic	See Page
10.1	Overview.....	181
10.2	Redundant PMM/APMM Configurations.....	181
10.3	Redundant IOP Placement.....	185
10.4	Redundancy Support	187
10.4.1	Power System.....	187
10.4.2	PMM/APMM and I/O Combinations	187

10.2 Redundant PMM/APMM Configurations

PMM/APMM card file types

PMM or APMM hardware, which consists of a five-card set, is available in two unique card file configurations. They are

- Single PMM/APMM card file—A single PMM or APMM with ten IOP card slots in a card file
- Redundant PMM/APMM card file—Two PMMs or APMMs with five IOP card slots in a card file

Redundant PMM/APMM card file

The redundant PMM/APMM card file provides PMM or APMM redundancy, but it is not a preferred application because both PMMs or APMMs share the same power system and backplane, reducing subsystem availability if the Power System or backplane should fail. The installed IOP cards also share the same Power System and backplane.

Two single PMM/APMM card files preferred

The two single PMM/APMM card file configuration is a preferred redundancy application because the card files can be powered by separate Power Systems. Maintenance can be performed on one card file while the other remains operational; however, they can be located one above the other in the same cabinet and share the same Power System.

Continued on next page

10.2 Redundant PMM/APMM Configurations, Continued

Redundant PMMs or APMMs in a single cabinet

Figure 10-1 illustrates a Process Manager or Advanced Process Manager subsystem with redundant PMMs or APMMs that share the same Power System in a single cabinet. The card files are shown with redundant pairs of AO and HLAI IOPs that are labeled “A” and “B.” When power is removed from one card file, the IOP’s partner can maintain communication with their associated FTA.

Figure 10-1 Single Cabinet with Redundant PMMs or APMMs

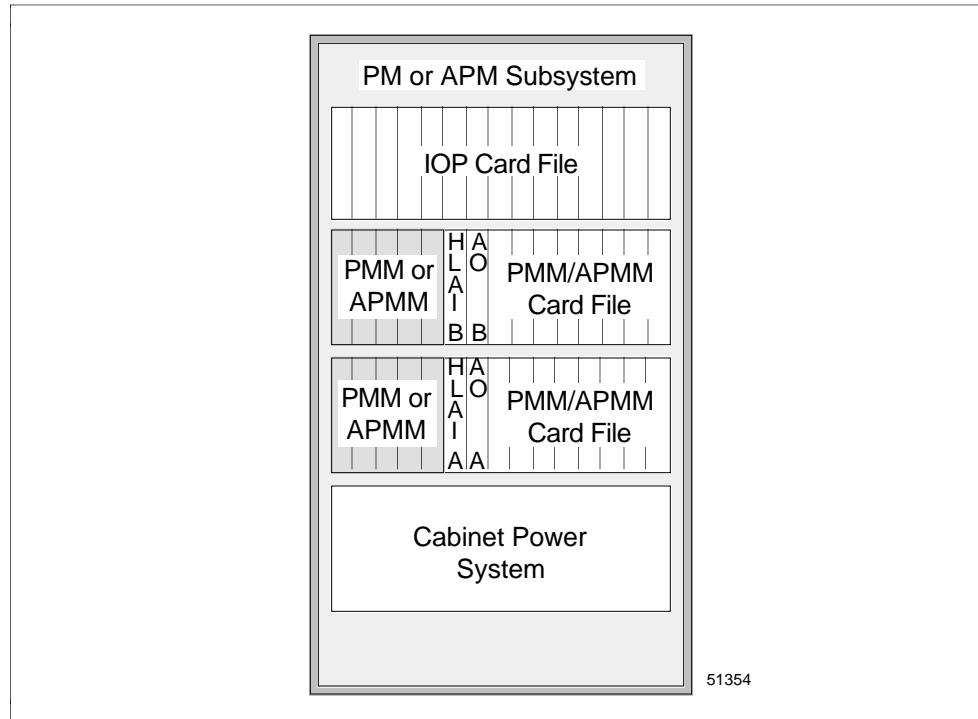

Continued on next page

10.2 Redundant PMM/APMM Configurations, Continued

Redundant PMMs or APMMs in separate cabinets

Card files can be located in an adjacent cabinet in a cabinet complex, with each cabinet having an independent Power System. Figure 10-2 illustrates a Process Manager or Advanced Process Manager subsystem with redundant PMMs or APMMs in separate cabinets, each with an independent Power System. Redundant pairs of HLAI, AO, and STI IOPs are shown and are labeled “A” and “B.”

Figure 10-2 Dual Cabinet with Redundant PMMs or APMMs

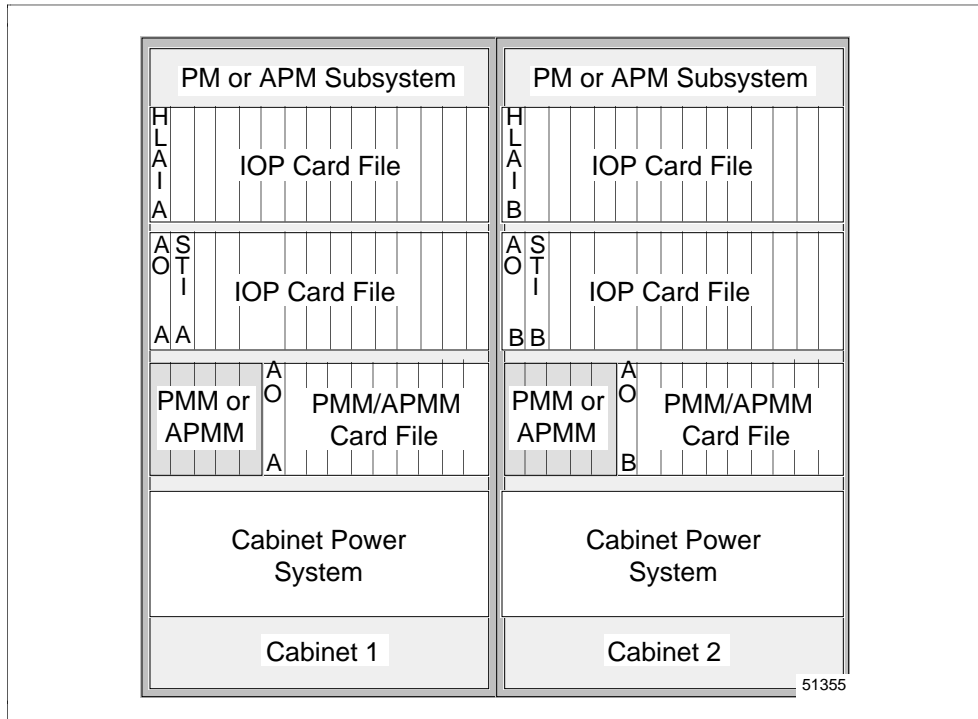

Continued on next page

10.2 Redundant PMM/APMM Configurations, Continued

Redundancy interface cable

If the PMM/APMM card files are located in separate cabinets, the cabinets must be adjacent because the redundancy interface cable between the card files cannot exceed 2 meters (6.5 feet). Figure 10-3 illustrates the redundancy cable connection between the two card files.

Figure 10-3 Redundant PMM or APMM Configuration Cabling

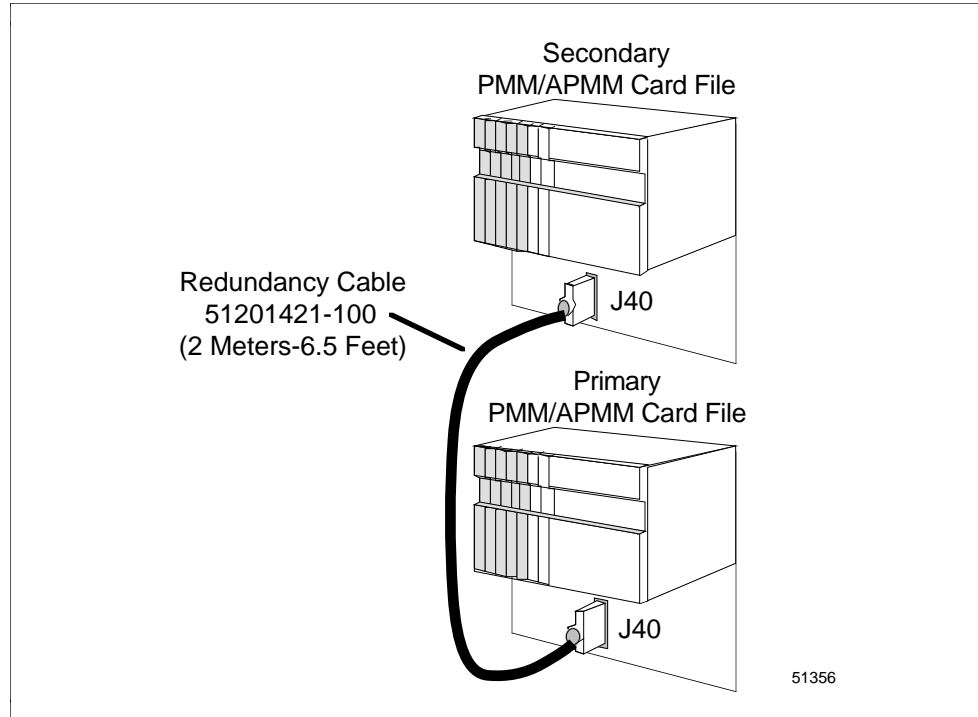

Additional power failure protection

The two single PMM or APMM card file configuration also provides the availability of 20 IOP card slots between the two card files. If the PMM or APMM card files are located in separate cabinets with independent Power Systems, the installed IOP cards are provided with additional subsystem failure protection.

10.3 Redundant IOP Placement

Recommendations

Some FTAs support redundant IOPs. The redundant IOP card pairs can be installed in any available slot in the card file and function properly; however, to take full advantage of IOP redundancy, consider the following recommendations.

Single PMM/APMM card files in separate cabinets

Redundant IOP card pairs in a Process Manager or Advanced Process Manager subsystem with the redundant PMMs or APMMs located in single PMM or APMM card files installed in separate cabinets of a complex, should be installed in card files in separate cabinets. Card files and separate cabinets, with independent Power Systems for both the redundant PMM or APMM card set and IOP cards, provide the maximum subsystem security and availability. Figure 10-2 is an illustration of a typical cabinet complex configuration.

As an aid to system maintenance, the IOP card pairs should also be installed in the same slot number in the separate card files.

Single PMM/APMM card files in same cabinet

Redundant IOP card pairs in a Process Manager or Advanced Process Manager subsystem with redundant PMMs or APMMs, located in single PMM or APMM card files within the same cabinet, should be installed in separate card files. The separate card files can consist of the two single PMM or APMM card files, or an additional IOP card file in the same cabinet as illustrated in Figure 10-1.

If the Process Manager or Advanced Process Manager subsystem is large enough, an additional card file in another cabinet in the same cabinet complex would provide an ideal location for the installation of one of the IOP card pair. The separate cabinet could provide an independent Power System.

As an aid to subsystem maintenance, the IOP card pairs should also be installed in the same slot number in the card files.

Redundant PMM/APMM card file

Redundant IOP card pairs, in a Process Manager or Advanced Process Manager subsystem with redundant PMMs or APMMs located in the same redundant PMM or APMM card file, should be installed in separate card files, with independent Power Systems.

As an aid to subsystem maintenance, the IOP card pairs should also be installed in the same slot number in each card file.

Continued on next page

10.3 Redundant IOP Placement, Continued

Redundant PMMs or APMMs recommended for redundant IOPs

Redundant IOP card pairs in a Process Manager or Advanced Process Manager subsystem with a single PMM or APMM is not recommended, but is feasible. The pair of IOPs should be installed in separate card files, with independent Power Systems if possible, and installed in the same slot number in each card file as an aid to system maintenance.

ATTENTION

ATTENTION—A remote redundant IOP card installation is functionally possible provided an I/O Link Extender is not installed between the IOP A and IOP B cards.

Both IOP cards of a redundant pair must be located within the distance permitted for the 50-meter FTA to IOP cables.

10.4 Redundancy Support

10.4.1 Power System

Power System capabilities

Assuming no Galvanically Isolated FTAs are installed in a Process Manager or Advanced Process Manager because of the increased power requirements, a single Power System can generally support the following PMM or APMM and IOP combinations.

- One PMM or APMM card file and up to 40 physical IOP cards with associated FTAs. This implies support for up to 20 redundant IOP card pairs.
 - One dual PMM or APMM card file and up to 35 physical IOP cards with their associated FTAs. The Power System will support up to 17 redundant IOP card pairs.
 - When only IOP card files are used, such as at a remote location, up to 40 physical IOP cards with their associated FTAs can be installed in the subsystem. The Power System will support up to 20 redundant IOP card pairs.
 - Normally, two Power Systems will support 40 redundant IOPs in two cabinets. The exception may be Galvanically Isolated FTAs because they have above normal power requirements.
-

10.4.2 PMM/APMM and I/O Combinations

Guidelines

For a redundant Process Manager or Advanced Process Manager subsystem, use the following guidelines for PMM or APMM and IOP card file combinations.

- Up to four IOP card files and two PMM or APMM card files can be supported in a redundant local I/O subsystem as shown in Figure 10-1.
 - A maximum of 40 redundant IOP card pairs, installed in up to six IOP card files in a remote redundant I/O subsystem, can be supported.
 - The total number of card files in a Process Manager or Advanced Process Manager cannot exceed eight (the maximum I/O Link Interface addresses available).
-

Continued on next page

10.4.2 PMM/APMM and I/O Combinations, Continued

Local/remote cabinet configuration

Figure 10-4 is an illustration of a local/remote Process Manager or Advanced Process Manager subsystem cabinet configuration. Redundant IOP pairs, “A” and “B,” are shown for a hypothetical installation.

Figure 10-4 Local/Remote Cabinet Configuration

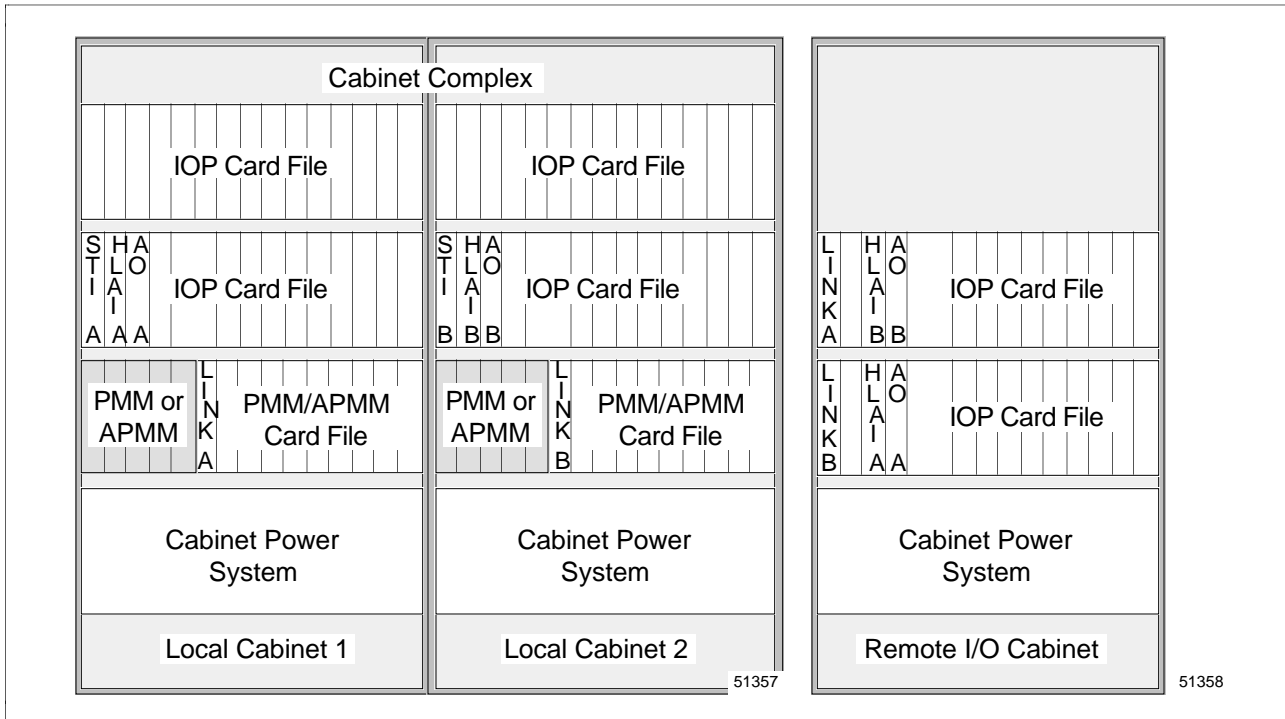

Section 11 – I/O Link Extender Planning

11.1 Overview

Section contents The topics covered in this section are:

	Topic	See Page
11.1	Overview.....	189
11.2	Description.....	190
11.3	Fiber Optic Cable Routing	196
11.3.1	Direct Burial.....	196
11.3.2	Aerial Lashing.....	196
11.3.3	Vertical Installations.....	197
11.3.4	Indoor Requirements.....	197
11.3.5	Loose Buffered Cable.....	197
11.3.6	Number of Fibers.....	198
11.3.7	Cable Installation.....	198
11.4	Indoor Cable Bend Radius.....	199
11.5	Cable Construction.....	199
11.6	Cable Splices and Connections.....	200
11.7	Loss Budget	202
11.7.1	Standard I/O Link Extender	202
11.7.2	Long Distance I/O Link Extender	204
11.8	Power Level Measurement.....	206

11.2 Description

Introduction	I/O Link Extenders provide the ability to locate a single IOP card file, or a complex of IOP card files, with IOPs and attached FTAs up to 8 kilometers (5 miles) from the PMM or APMM. Two types of I/O Link Extenders and their associated fiber optic couplers are available, the “Standard” I/O Link Extender with up to a 1.3 kilometers link and the “Long Distance” I/O Link Extender with up to a 8 kilometers link. The connection is made by using a pair of fiber optic transmission cables, driven and terminated by a fiber optic coupler that mates with the connector located directly below the I/O Link Extender card in the card file.
I/O Link Extender cards	Each I/O Link Extender consists of two I/O Link Extender cards, one for Link A and one for Link B, that occupy two slots in the PMM or APMM and IOP card file.
Standard I/O Link Extender couplers	Each Standard I/O Link Extender card has an associated fiber optic coupler that can drive up to three pair of fiber optic cables. Each cable pair is terminated by a fiber optic coupler that terminates one fiber optic pair.
Long Distance I/O Link Extender couplers	Each Long Distance I/O Link Extender card has an associated fiber optic coupler that drives a single pair of fiber optic cables. Each cable pair is terminated by a fiber optic coupler that terminates one fiber optic pair.
Remote card file requirements	Every remote card file requires two I/O Link Extender cards and two fiber optic couplers, one for Link A and one for Link B.
Standard I/O Link Extender assignment	The Standard I/O Link Extender card will drive and terminate Link A or Link B, depending upon the card file’s I/O Link Interface address and in which card file slot number the card is installed. If the card file’s I/O Link Interface address and card slot number’s I/O Link Interface address are both odd or both even, the card will drive I/O Link A. If the card file’s I/O Link Interface address and slot number’s I/O Link Interface address are <u>not</u> both odd or both even, the card will drive I/O Link B.
Metallic I/O Link Interface cable required	Metallic I/O Link Interface cables are required between redundant PMM or APMM card files to provide communication between the IOPs and PMMs or APMMs in the card files.

Continued on next page

11.2 Description, Continued

Nonredundant PMM or APMM

Figure 11-1 illustrates the interconnections for a Standard I/O Link Extender in a Process Manager or Advanced Process Manager that contains a nonredundant PMM or APMM. The following PM or APM subsystem configuration is assumed.

- The PMM or APMM card file is configured as card file #1 (I/O Link Interface address of 0).
- Remote site # 1's I/O card file is configured as card file # 2 (I/O Link Interface address of 1).
- Remote site # 2's I/O card file is configured as card file # 3 (I/O Link Interface address of 2).
- Remote site # 3's I/O card file is configured as card file # 4 (I/O Link Interface address of 3).

Figure 11-1 Standard I/O Link Extender Interconnections with Nonredundant PMM or APMM

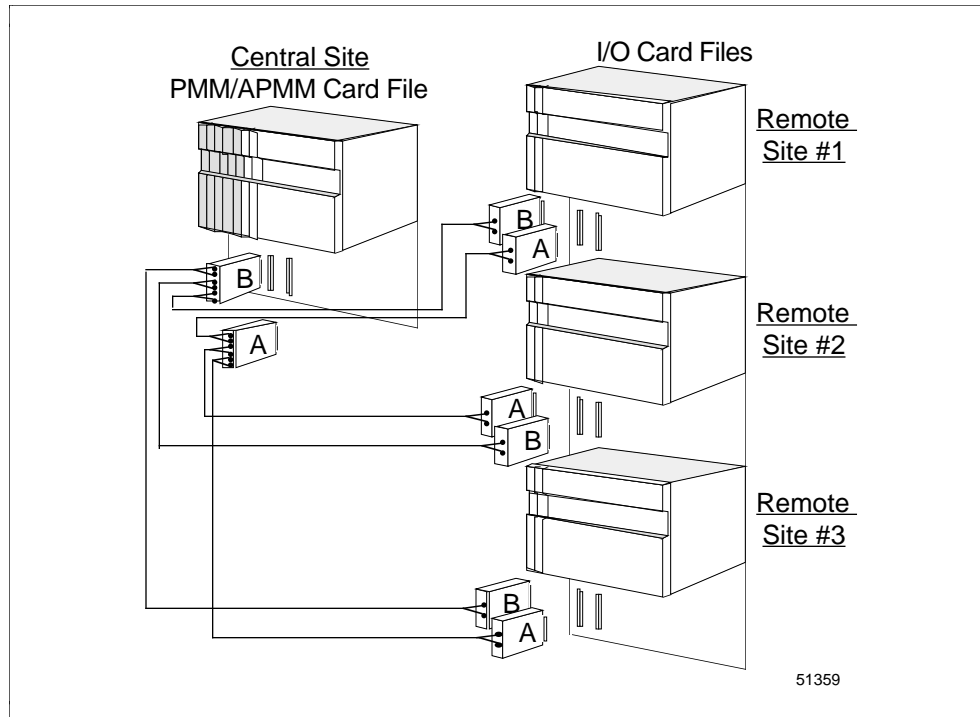

Continued on next page

11.2 Description, Continued

Redundant PMMs or APMMs

Figure 11-2 illustrates the interconnections for a Standard I/O Link Extender in a Process Manager or Advanced Process Manager that contains redundant PMMs or APMMs. The following PM or APM subsystem configuration is assumed.

- The lower PMM or APMM card file is configured as card file #1 (I/O Link Interface address of 0).
- The upper PMM or APMM card file is configured as card file #2 (I/O Link Interface address of 1).
- Remote site # 1's I/O card file is configured as card file # 3 (I/O Link Interface address of 2).
- Remote site # 2's I/O card file is configured as card file # 4 (I/O Link Interface address of 3).
- Remote site # 3's I/O card file is configured as card file # 5 (I/O Link Interface address of 4).

Figure 11-2 Standard I/O Link Extender Interconnections with Redundant PMMs or APMMs

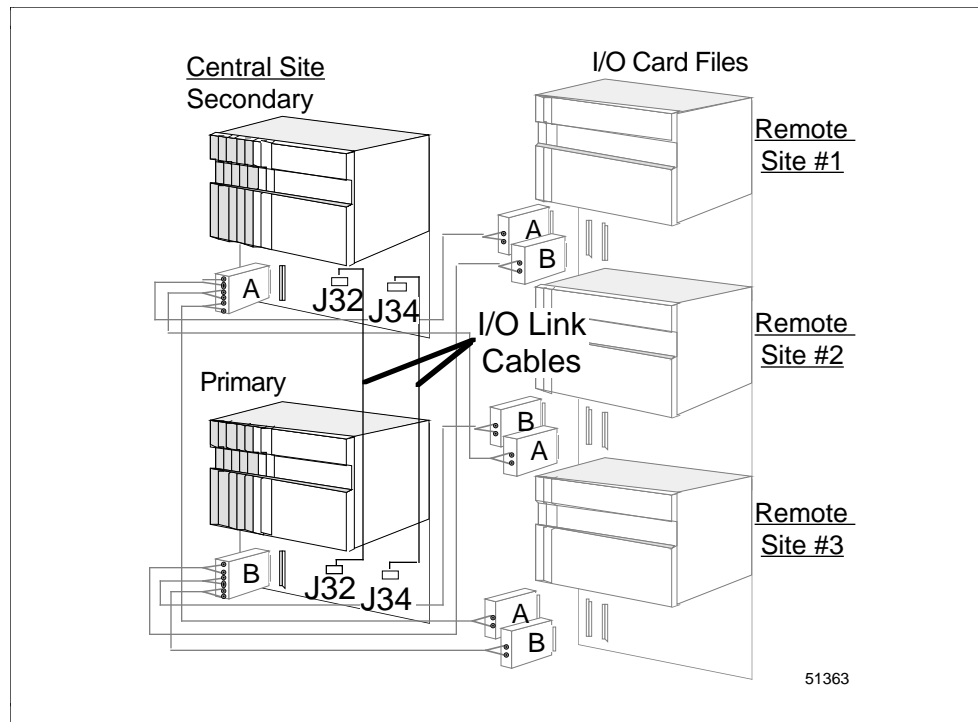

Continued on next page

11.2 Description, Continued

Long Distance I/O Link Interface assignment

Configuration of the A and B Long Distance I/O Link Extender is determined by a jumper on the I/O Link Extender card.

Metallic I/O Link Interface cable required

Metallic I/O Link Interface cables are required between redundant PMM or APMM card files to provide communication between the IOPs and PMMs or APMMs in the card files.

Nonredundant PMM or APMM

Figure 11-3 illustrates the interconnections for a Long Distance I/O Link Extender in a Process Manager or Advanced Process Manager that has a nonredundant PMM or APMM.

Link A and B selection is determined by jumper selection on the I/O Link Extender card.

Figure 11-3 Long Distance I/O Link Extender Interconnections with Nonredundant PMM or APMM

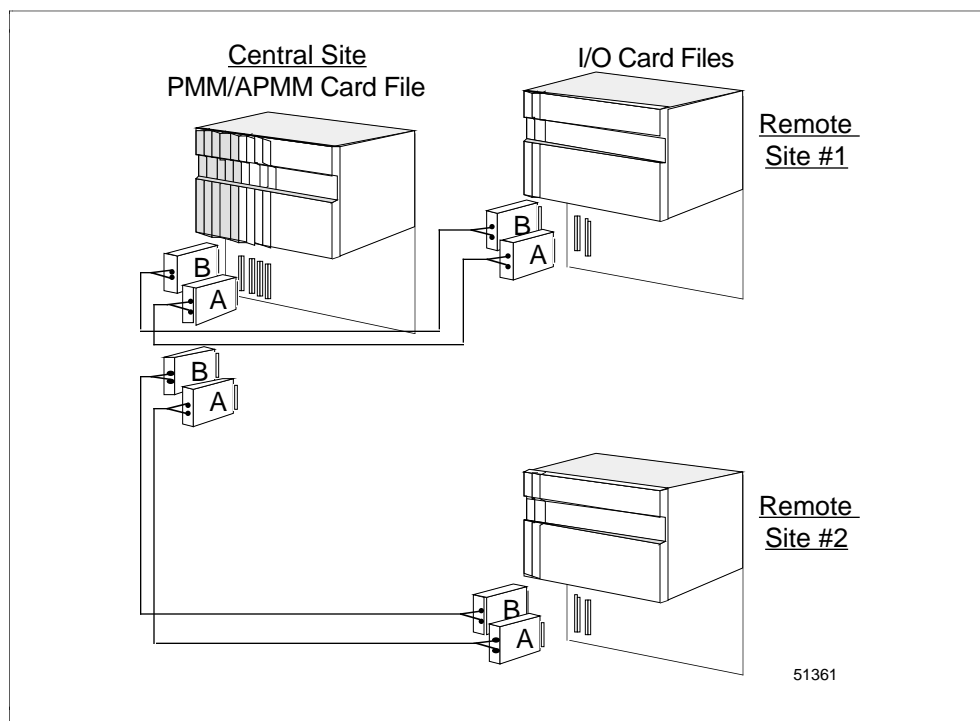

Continued on next page

11.2 Description, Continued

Redundant PMMs or APMMs

Figure 11-4 illustrates the interconnections for a Long Distance I/O Link Extender in a Process Manager or Advanced Process Manager that has redundant PMMs or APMMs.

Link A and B selection is determined by jumper selection on the I/O Link Extender card.

Figure 11-4 Long Distance I/O Link Extender Interconnections with Redundant PMMs or APMMs

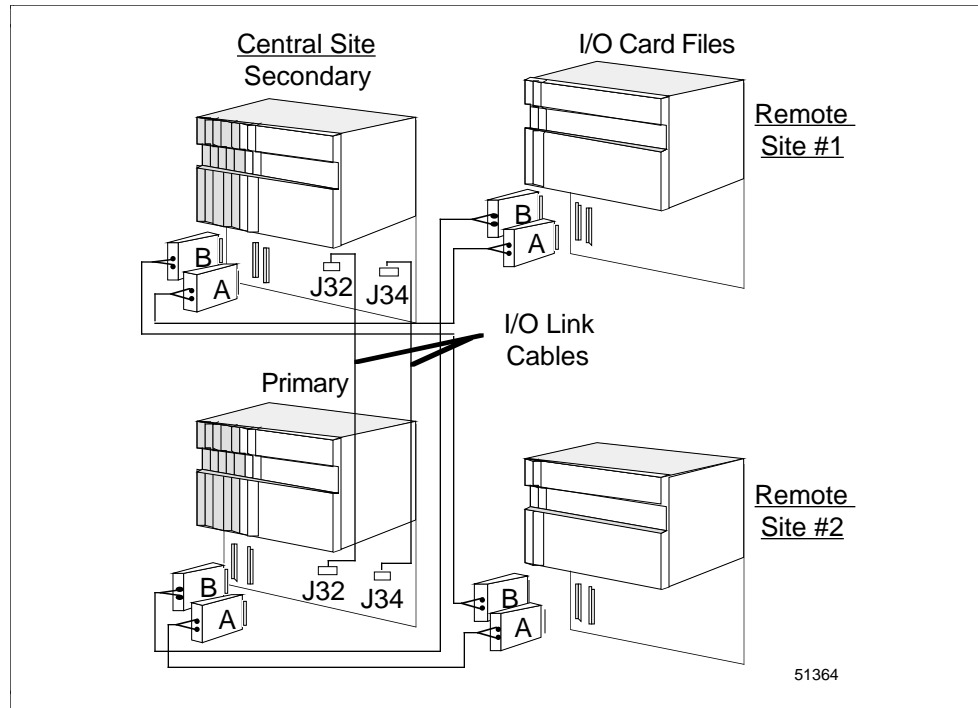

Continued on next page

11.2 Description, Continued

Number of remote card files Two Standard I/O Link Extenders, connecting up to six remote card files, can be installed in a PMM or APMM card file, but the maximum number of other primary IOPs is still 40 (plus 40 redundant IOPs).

Maximum fiber optic cable length The maximum fiber cable length is dependent upon the number of splices and quality of the cable (dB loss per meter of cable). This maximum can be between 0.98 and 1.3 kilometers for the Standard I/O Link Extender and up to 8 kilometers for the Long Distance I/O Link Extender. See subsection 11.6 for the loss budget calculation.

Remote card file installation For remote locations consisting of more than one IOP card file, the A and B I/O Link Extender cards are installed in separate card files, and the card files are interconnected with the standard metallic I/O Link Interface cables as shown in Figure 11-5. As an example, the following PM or APM subsystem configuration is assumed.

- The lower PMM or APMM card file is configured as card file #1 (I/O Link Interface address of 0).
- The upper PMM or APMM card file is configured as card file #2 (I/O Link Interface address of 1).
- The remote site's upper I/O card file is configured as card file # 3 (I/O Link Interface address of 2).
- The remote site's lower I/O card file is configured as card file # 4 (I/O Link Interface address of 3).

Figure 11-5 Remote Site Multi-IOP Card File I/O Link Interface Cabling

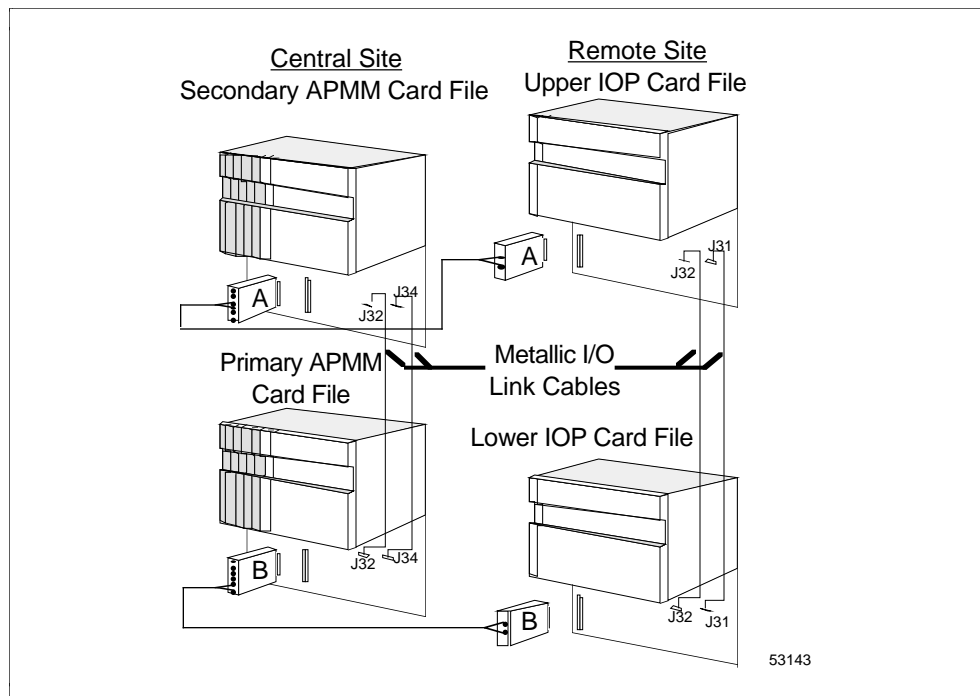

11.3 Fiber Optic Cable Routing

Routing methods Fiber optic cable can be routed underground (with direct burial cable), through the air (with outdoor aerial cable), or in cable and electrical wiring trays. Fiber optic cable is immune to interference from electromagnetic fields or transmissions. Fiber optic cable is safe to route through intrinsic safety areas with no danger of explosion.

Cable A and B separation The A and B fiber links should be routed to the destination by different routes to avoid simultaneous damage or cutting to both cables; however, the maximum difference in fiber optic cable length between Link A and Link B must be less than 500 meters (1640 feet) to limit the communications delay difference between Link A and Link B.

11.3.1 Direct Burial

Under ground burial hazards Heavy duty cables can be buried directly in the ground. Care should be taken to minimize the effects of freezing water, the heaving of rocks caused by the ground freezing, ground disruption because of construction, and rodents.

Type of cable to use The most durable jacket material for environmental hazards, such as crushing and abrasion, is polyethylene. An inner layer of steel armor provides additional protection from rodents. Use of heavy duty cables can sometimes be avoided by protecting the cable with conduit or polyethylene pipe.

11.3.2 Aerial Lashing

Aerial lashing methods Aerial Lashing methods are similar to those used for electrical cables. Most cables are compatible with helical lashing, clamping, or tied mounting.

11.3.3 Vertical Installations

Cable clamping

Cable in vertical trays, raceways, shafts, etc., should be firmly clamped at frequent intervals so that cable weight is supported evenly. Clamping intervals can be as short as one meter (3.3 feet) outdoors to prevent wind slapping and minimize ice loading, or as long as 15 meters (49.2 feet) in interior locations.

Fiber migration

Fiber in vertical installations does not break because of its own weight; however, for vertical runs of 15 meters (49.2 feet), and greater, excess fiber can migrate downward. The crowding of excess fiber at the bottom can cause an increase in attenuation.

Cable loops

This downward migration of fiber in vertical runs can be reduced by placing loops in the cable, approximately 0.3 to 0.5 meter (1 to 1.5 feet) in diameter, at the top, bottom, and at 150-meter (500-foot) intervals.

11.3.4 Indoor Requirements

Cable jacket building code restrictions

Building code requirements frequently do not allow cables with polyethylene jackets. Jackets of polyvinyl chloride are frequently restricted to conduits, while fluoropolymer or other approved jacket material is required for use in cable trays and air plenums. Cable with suitable jacket material must be selected for the application.

11.3.5 Loose Buffered Cable

Ambient temperature variations

Where ambient temperature variations are 20°C or greater on a daily basis, the life of the fibers can be significantly reduced. In applications where the ambient temperature is not controlled, loose buffered cable must be specified.

Fire code requirements

Loose buffered cable is available in polyethylene jacket material only. Fire codes may dictate that the indoor portion of the cable installation be in metal conduit, or if the temperature is controlled, a splice may be required to convert to a tight buffer cable with a PVC or Fluoride Co-Polymer jacket material.

11.3.6 Number of Fibers

Multi-fiber cable required

Two fibers are required for one link, one for transmit and one for receive. Fiber loss is measured at $22^{\circ}\text{C} \pm 3^{\circ}$ and is usually stated as a mean value. Individual fiber losses may be as much as 25% greater than the mean.

Cable damage possible

As insurance against future damage, such as fiber breakage, or encountering excessive loss in any one fiber, the inclusion of spare fibers should be considered. This is especially important for cables that have high installation cost.

11.3.7 Cable Installation

Use professional installers

It is recommended that the fiber optic cable be installed by professional installation contractors. The installers will provide the cable, install the cable, attach ST-type connectors, and do the OTDR test.

62.5 micron cables

62.5 micron cable usage is controlled by Honeywell purchase specification 51190918 for indoor cable and Honeywell purchase specification 51190919 for outdoor cable.

Indoor cables are available with 2, 4, or 6 fibers.

Outdoor aerial and direct burial cables are available with 4, 6, or 8 fibers.

100 micron cables

100 micron cable usage is controlled by Honeywell purchase specification 51190697 for indoor cable and Honeywell purchase specification 51190698 for outdoor cable.

Indoor cables are available with 2, 4, or 6 fibers.

Outdoor aerial and direct burial cables are available with 4, 6, or 8 fibers.

11.4 Indoor Cable Bend Radius

Cable bend requirements

Fiber optic cable is easily damaged by overbending or kinking the cable, so a minimum bend radius is established for each different cable size and cable construction. Indoor cable is the most flexible and outdoor direct burial cable is the least flexible. Table 11-1 specifies the minimum bend radius for indoor cable.

In the table, short term minimum bend radius refers to the minimum bend radius that is safe during installation. Long term minimum bend radius refers to the minimum bend radius that is safe after the cable installation is completed and settled.

Table 11-1 Minimum Bend Radius for Indoor Cable

Fibers Per Cable	Minimum Bend Radius (Short Term)	Minimum Bend Radius (Long Term)
2	17.0 cm (6.7 in.)	13.0 cm (5.1 in.)
4	22.0 cm (8.7 in.)	16.5 cm (6.6 in.)
6	26.0 cm (6.7 in.)	20.0 cm (7.9 in.)
8	30.0 cm (6.7 in.)	23.0 cm (9.0 in.)

11.5 Cable Construction

Fiber optic cable selection

The selection of fiber optic cable is dependent upon satisfying installation and environmental requirements without exceeding the maximum optical losses. The factors to be considered when selecting the cable are

- The total fiber optic cable losses
- The cable requirements caused by the desired routing. Routing requirements can include direct burial, conduits, trays, raceways, plenums, etc.
- Construction code requirements

Installation precautions

The installation procedures for placement of fiber optic cables are the same as for electrical wires. Care should be taken to avoid yanking, flipping, or wrapping that can result in unnecessary tightening of the fibers. Fiber optic cables should not be subject to foot traffic or crushing forces. Sharp bending and scraping at entrances and covers should be avoided.

11.6 Cable Splices and Connections

Planning the cabling	When planning a system installation, design the system to have the minimum number of splices. For example, convert outdoor cable to indoor cable when entering a cabinet where the bend radius of outdoor cable will not fit in the cabinet. Where this splicing must be made, sufficient cable length must be provided for a splice loop. Thirty to forty-five centimeters (12 to 18 inches) on each cable end is the usual allowance for a service loop. Also, when entering the equipment cabinet, sufficient cable length must be allowed for breakout (stripping and fanning out) and termination of the individual fibers.
Cable splice protection	Completed splices cannot withstand tensile forces and must be housed in a strain relief assembly. Moisture entry into the splice can cause degradation of performance; therefore, the splice enclosure must be sealed, and if necessary, the splice encapsulated to minimize moisture entry.
Cable breakout	Breakout eliminates the outer sheath, leaving the more flexible individual fibers for routing within the cabinet. Tight buffer indoor cables (discussed in subsection 11.2.5) provide strength members with each fiber, eliminating the need to use breakout kits to add strength members for each fiber.
Use of a breakout kit	In outdoor loose-buffered, gel-filled cable designs, there is no strength member or protective jacket for the individual fibers. To terminate and use this type of cable requires the use of a breakout or fan-out kit. The kit provides strength members with flexible jackets that are placed over the fibers after the outer jacket is removed. These kits can be installed over fibers as much as 10 meters (33 feet) in length. The kit provides fiber protection for in-cabinet routing and termination.

Continued on next page

11.6 Cable Splices and Connections, Continued

Cables with connectors preinstalled

If the cable length is accurately determined and the cable does not have to be pulled through a conduit, the cables can be ordered with connectors installed on the ends. This requires less field skill and installation time. ST-type connectors, as shown in Figure 11-6, can also be used as a means of splicing two cables; however, to minimize losses at or near maximum cable lengths, professional installation is required, using fusion splices.

Figure 11-6 ST-Type Connector

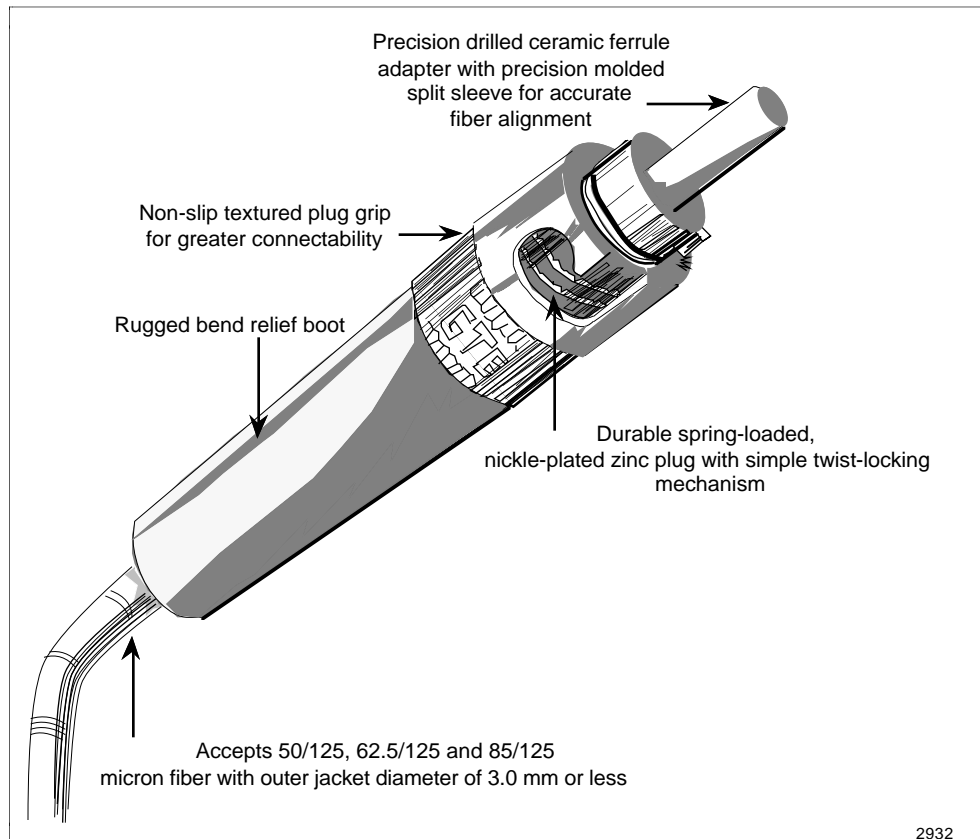

11.7 Loss Budget

Introduction

The fiber cable loss budget is the difference between the transmit power and the minimum receiver sensitivity, minus the desired loss margin.

11.7.1 Standard I/O Link Extender

Loss budget calculation The loss budget for the Standard I/O Link Extender is calculated as follows.

Transmit Power - Receiver Sensitivity = Budgeted Losses

<u>Component</u>	<u>dB Level</u>
Transmitter (62.5 micron fiber)	-16.0
Receiver	(-) -24.0
	8.0
Less power loss over time	(-) 2.5
Available optical cable power	5.5

ATTENTION

ATTENTION—Because the maximum transmitter output level is -7 dB, and the maximum receiver input level is -10 dB, the receiver may be overdriven on a short link and may require a 3 dB attenuator. Connector allowances for the transmitter and receiver are included in the above power declaration.

Types of splices

Two types of splices are available, mechanical and fusion.

The mechanical-type of splice consists of a glass tube into which the fiber is secured by ultra violet (UV) curable epoxy.

The fusion-type splice is produced by carefully aligning the fibers and then fusing them together by heating the fibers.

In both cases, the loss in the resulting splice is very dependent upon the skill of the installer. The losses at all splices and cable installations need to be certified and recorded at the time of installation for future reference as described in subsection 11.8.

Continued on next page

11.7.1 Standard I/O Link Extender, Continued

Cable span distance formula

To calculate the maximum distance the cable can reliably span

$$\frac{5.5 - (\text{losses in splices})}{\text{Maximum cable loss in dB/km}} = D, \text{ the distance}$$

The maximum distance for a Premium Performance cable with two fusion splices can be calculated using Tables 11-2 and 11-3.

$$\frac{5.5 - (2 \times 0.3)}{4} = 1.22 \text{ km}$$

The maximum distance for High Performance cable with two mechanical splices can be calculated using Tables 11-2 and 11-3.

$$\frac{5.5 - (2 \times 0.5)}{4} = 1.12 \text{ km}$$

Table 11-2 Standard Optical Power Loss

Type of Splice	Average Loss (dB)	Maximum Loss (dB)
Fusion	0.2	0.3
Mechanical	0.3	0.5
ST-Connector	0.5	0.9

Table 11-3 Standard Fiber Optic Cable Losses (@ 850 nm)

Type of Splice	Average Loss (dB/km)	Maximum Loss (dB/km)
Fusion	3.75	4.0
Mechanical	3.75	4.0
ST-Connector	3.50	4.0

11.7.2 Long Distance I/O Link Extender

Loss budget calculation The loss budget for the Long Distance I/O Link Extender is calculated as follows.

Transmit Power - Receiver Sensitivity = Budgeted Losses

<u>Component</u>	<u>dB Level</u>
Transmitter (62.5 micron fiber)	-18.0
Receiver	(-) <u>-31.5</u>
	13.5
Less power loss over time	(-) <u>4.5</u>
Available optical cable power	9.0

ATTENTION

ATTENTION—Connector allowances for the transmitter and receiver are included in the optical cable power calculation shown above.

Types of splices

Two types of splices are available, mechanical and fusion.

The mechanical-type of splice consists of a glass tube into which the fiber is secured by ultra violet (UV) curable epoxy.

The fusion-type splice is produced by carefully aligning the fibers and then fusing them together by heating the fibers.

In both cases, the loss in the resulting splice is very dependent upon the skill of the installer. The losses at all splices and cable installations need to be certified and recorded at the time of installation for future reference as described in subsection 11.8.

Continued on next page

11.7.2 Long distance I/O Link Extender, Continued

Cable distance formula To calculate the maximum distance the cable can reliably span for the model MU-ILDX03 I/O Link Extender, use the following formula.

$$\frac{9.0 - (\text{losses in splices})}{\text{Maximum cable loss in dB/km}} = D, \text{ the distance}$$

The maximum distance for a Premium Performance cable with two fusion splices can be calculated using Tables 11-4 and 11-5.

$$\frac{9.0 - (2 \times 0.3)}{2} = 4.2 \text{ km}$$

The maximum distance for High Performance cable with two mechanical splices can be calculated using Tables 11-4 and 11-5.

$$\frac{9.0 - (2 \times 0.5)}{2} = 4.0 \text{ km}$$

Table 11-4 Long Distance Optical Power Loss

Type of Splice	Average Loss (dB)	Maximum Loss (dB)
Fusion	0.2	0.3
Mechanical	0.3	0.5
ST-Connector	0.5	0.9

Table 11-5 Long distance Fiber Optic Cable Losses (@ 1300 nm)

Type of Splice	Average Loss (dB/km)	Maximum Loss (dB/km)
Fusion	1.5	2.0
Mechanical	1.5	2.0
ST-Connector	1.0	2.0

11.8 Power Level Measurement

Record post installation measurements

After the cables have been connected to the fiber optic transmitters and power has been applied to the equipment, measurements of transmitter output, cable loss and power input to the fiber optic receivers should be recorded for future reference. This procedure is detailed in the *Process Manager I/O Installation* manual.

Section 12 – Low Level Multiplexer Planning

12.1 Overview

Section contents The topics covered in this section are:

	Topic	See Page
12.1	Overview.....	207
12.2	LLMux Configurations.....	207
12.3	LLMux IOP Placement	210
12.4	Power Adapter Placement.....	210
12.5	LLMux FTA Placement.....	210
12.6	Remote CJR Installation	213

12.2 LLMux Configurations

CE Compliance

All models of the Low Level Analog Input Multiplexer (LLMux) Field Termination Assemblies (FTAs) and the Power Adapter can be used in a CE Compliant application; however, they must be used with the model MU-KFTSxx IOP to FTA cable and the IOP(s) must be installed in a CE Compliant card file. Table 12-1 lists FTA and Power Adapter model and part numbers.

Table 12-1 Low Level Analog Input Multiplexer FTAs

Model Number	Description	Part Number
MU-TAMR03	RTD LLMux FTA – IOP Nonredundancy	51309218-125
MC-TAMR03	RTD LLMux FTA – Conformally Coated	51309218-175
MU-TAMT03	TC LLMux FTA – IOP Nonredundancy	51309223-125
MC-TAMT03	TC LLMux FTA – Conformally Coated	51309223-175
MU-TAMT13	TC LLMux FTA with Remote CJR – IOP Redundancy	51309213-125
MC-TAMT13	TC LLMux FTA with Remote CJR – Conformally Coated	51309213-175
MU-TLPA02	Power Adapter	51309204-125
MU-TLPA02	Power Adapter	51309204-175

Continued on next page

12.2 LLMux Configurations, Continued

Non-CE Compliance	The FTAs and the Power Adapter can also be used for a non-CE Compliance application. The model MU-KFTAxx IOP to FTA cable can be substituted for the model MU-KFTSxx cable.
Conformal coating	All models of the LLMux FTA and the Power Adapter are available with conformal coating. See Table 12-1.
Power Adapter	A CE Compliant version of the model MU-TLPA02 Power Adapter (part number 51309204-125 or 51309204-175) must be used with the LLMux FTA models for a CE Compliant application.
Description	<p>Figure 12-1 illustrates a Low Level Analog Input Multiplexer (LLMux) configuration.</p> <p>In Figure 12-1, the LLMux FTA, model MU-TAMR03 or MU-TAMT03/13, communicates with a model MU-PLAM02 LLMux IOP through the model MU-TLPA02 Power Adapter. This can be a non-CE Compliant or CE-Compliant application depending upon the model of the IOP to FTA cable and the model of the card file.</p>
Two types of LLMux FTAs	<p>The LLMux FTAs that connect to the Power Adapter can be either of two types of FTAs; the model MU-TAMT03/13 Thermocouple (TC) FTA or the model MU-TAMR03 Resistive Temperature Device (RTD) FTA. The combination of the FTA mother board and the daughter board determines the type of FTA.</p> <p>The two LLMux FTAs that connect to the Power Adapter can be the same type, or different types.</p>
Two thermocouple LLMux FTAs	There are two versions of the Thermocouple LLMux FTA. The model MU-TAMT03 FTA has a single local Cold Junction Reference (CJR) interface, while the model MU-TAMT13 FTA has a remote CJR interface. This allows the CJR to be located up to 50 meters (164 feet) from the FTA with the use of appropriate cabling.
16 LLMux FTA channels	Each type of LLMux FTA has 16 channels that accept low level analog inputs. Two LLMux FTAs connected to a Power Adapter provide 32 channel inputs to the LLMux IOP. This concept causes the LLMux to be known also as the 32-point LLMux.

Continued on next page

12.2 LLMux Configurations, Continued

CE Compliant LLMux configuration

Figure 12-1 LLMux Configuration Interconnections—CE Compliant

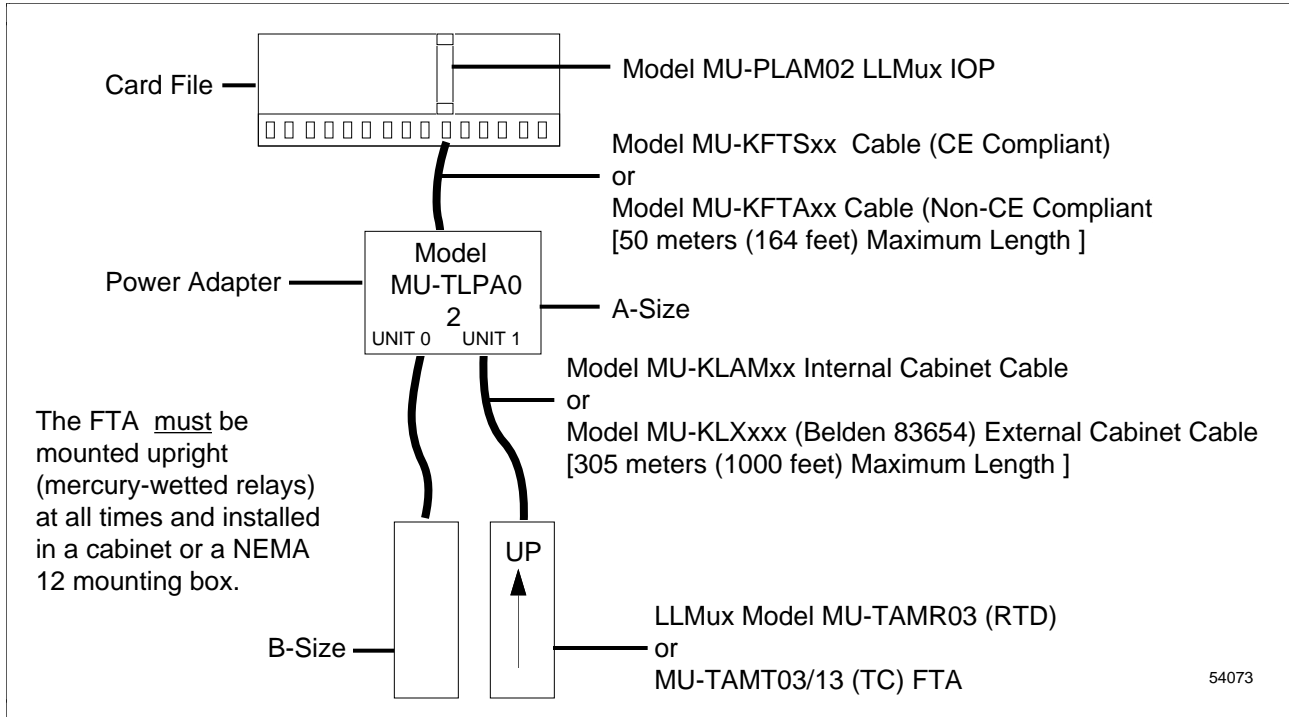

12.3 LLMux IOP Placement

Install the IOP in any card file

The LLMux IOP can be installed in any available slot in a PMM, APMM, or IOP card file.

12.4 Power Adapter Placement

Within 50 meters of IOP

The Power Adapter can be installed on any available FTA Mounting Channel that is within 50 meters (164 feet) of the LLMux IOP. The restriction is that the longest IOP to FTA cable cannot exceed 50 meters.

IOP to Power Adapter cable

The IOP to Power Adapter interconnection is provided by a model MU-KFTAxx nonshielded cable (the suffix “xx” represents the length of the cable in meters) in 12 sizes, up to 50 meters (164 feet) in length in a non-CE Compliance application. A model MU-KFTSxx shielded cable is used for a CE Compliant application. See the *Process Manager/Advanced Process Manager Service* or *Process Manager/Advanced Process Manager Installation* manual for the exact sizes available.

Power Adapter size

The Power Adapter has the same dimensions as an A-size (6 inches) FTA.

12.5 LLMux FTA Placement

FTA size

The LLMux FTA is a B-size (12 inches) FTA

EMI sensitivity

The LLMux FTA designed to be in a shielded enclosure. This can be accomplished in either of two ways:

- Install the FTA in a standard Process Manager or Advanced Process Manager cabinet on an FTA Mounting Channel. The FTA is grounded to the cabinet and the cabinet must be grounded to Safety Ground (building ground).
 - Install the FTA in a NEMA 12 box with the FTA Mounting Channel grounded to the box, and the box connected to Safety Ground.
-

WARNING

WARNING—The practice of mounting an FTA on panel rails is not acceptable because the installed FTA can not be adequately shielded. The FTA must mount on an FTA Mounting Channel.

Continued on next page

12.5 LLMux FTA Placement, Continued

Within 305 meters of Power Adapter

The remote LLMux cabinet or NEMA 12 box can be located up to 305 meters (1000 feet) from the Power Adapter. The restriction is that the longest Power Adapter to FTA cable cannot exceed 305 meters (1000 feet).

CAUTION

CAUTION—The remotely-installed FTA's environment must meet the same environmental conditions imposed on equipment installed in Process Manager or Advanced Process Manager cabinets. See Section 5 in this manual and the *TDC 3000^X System Site Planning* and *Process Manager I/O Installation* manuals for additional information.

Mercury-wetted relay contacts

LLMux FTAs contain relays with mercury-wetted contacts and must be positioned with the LLMux power connector-side up.

Local FTA to Power Adapter cabling

When the LLMux FTA is installed in the same cabinet, or cabinet complex, as the Power Adapter FTA, a model MU-KLAMxx cable (“xx” represents five sizes – 30, 66, 100, 200, and 300 centimeters) with stripped wire ends is used for the interconnection. See the *Process Manager/Advanced Process Manager Service* manual for part numbers.

The cable can be used for both non-CE Compliant and CE Compliant applications.

The cable has two individually shielded twisted-pair wires. The shields must be connected to ground at the Power Adapter end only. The wire connections are made by using the compression terminals in a 6-pin connector at the Power Adapter end and a 4-pin connector at the FTA end.

External Power Adapter to FTA cabling

When LLMux FTA is not installed in the same cabinet, or cabinet complex, as the Power Adapter and up to 305 meters (1000 feet) from the Power Adapter, a model MU-KLXxxx cable (“xxx” represents three sizes – 76, 152, and 305 meters for external cabinet installation) must be used. This is Belden type 83654 cable with a braided shield and must be used for the interconnection for a CE Compliance application. See the *Process Manager/Advanced Process Manager Service* manual for part numbers.

References

For additional LLMux IOP and FTA information, see the *Process Manager I/O Installation* or *Process Manager/Advanced Process Manager Service* manual.

Continued on next page

12.5 LLMux FTA Placement, Continued

Power Adapter to FTA cable specifications

The model MU-KLAMxx (internal) and model MU-KLXxxx (external) cables have the following specifications.

Model MU-KLAMxx power cable (internal cabinet use)

- Manufacturer Type—Belden 9406
 - Configuration—Shielded double pair
 - Flame Resistance Conformity—CSA FT 4
 - CSA Type—CMG
 - NEC Type—CM
-

Model MU-KLXxxx power cable (external cabinet use)

- Manufacturer Type—Belden 83654
 - Conductors—Shielded double pair (Teflon jacket)
 - Flame Resistance Conformity —CSA FT 4/FT6 and UL910
 - CSA Type—CMP
 - NEC Type—CMP
 - Temperature: -70°C to +200°C
-

Model MU-KRCJ00 remote CJR cable

- Manufacturer Type—Belden model 83653
 - Conductors—Three 1.0 mm² (18 AWG) conductors
 - Insulation and Jacket—Teflon conductor insulation and jacket
 - Shielding—Braid over foil
 - Flame Resistance Conformity—CSA PCC FT4/FT 6 and UL910
 - NEC Type—CMP
 - Use—Air plenum
-

12.6 Remote CJR Installation

Installation requirements

Figure 12-2 illustrates remote CJR installation requirements. Model MU-KRCJ00 cable must be used between the remote CJR sensor and the model MU-TAMT13 or MC-TAMT13 FTA. Its length is restricted to 50 meters (164 feet). The cable shield must be connected to Safety Ground at both ends of the cable.

The installation as illustrated is CE Compliant.

Figure 12-2 Remote CJR Installation

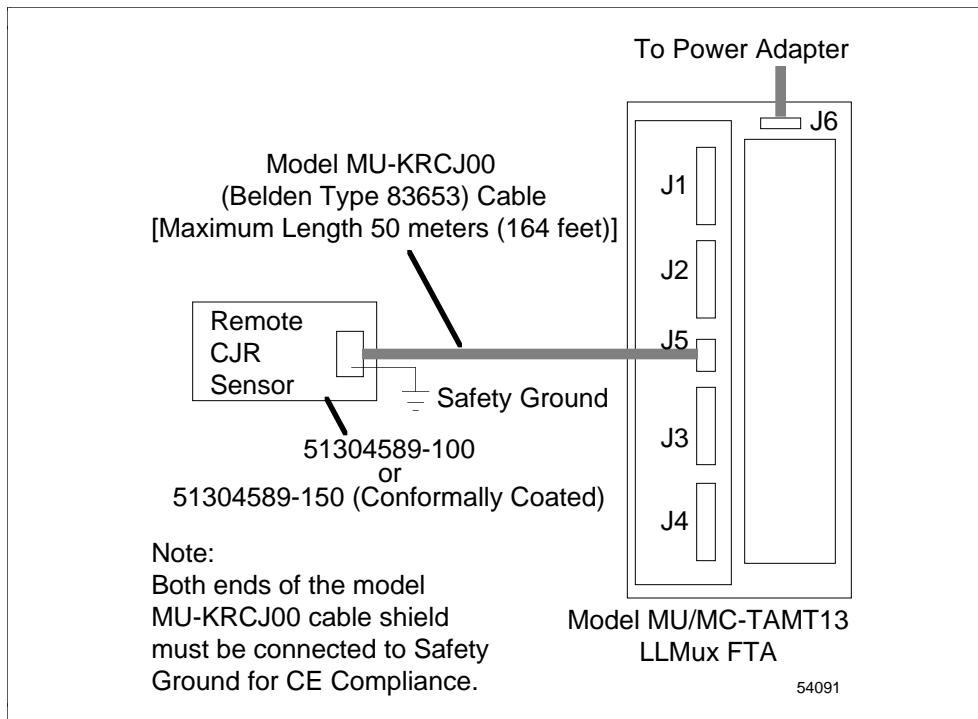

Section 13 – Serial Device Interface Planning

13.1 Overview

Section contents The topics covered in this section are:

	Topic	See Page
13.1	Overview.....	215
13.2	Serial Device Interface Configurations.....	215
13.3	Serial Device Interface IOP Placement.....	217
13.4	Power Adapter Placement.....	217
13.5	IOP to Power Adapter Cabling.....	217
13.6	Serial Device Interface FTA Placement.....	218
13.7	FTA to Power Adapter Cabling.....	218
13.8	FTA Field Cabling.....	220
13.9	Serial Device Interface FTA Models.....	221

13.2 Serial Device Interface Configurations

Overview

There are three models of the Serial Device Interface (SDI) FTA, MU-TSDT02, MU-TSDM02, and MU-TSDU02. All the FTA models interface with the model MU-PSDX02 Serial Device Interface IOP. One or two Serial Device Interface FTAs can communicate with a single model MU-PSDX02 Serial Device Interface IOP through the model MU-TLPA02 Power Adapter.

FTA plug-in module determines application

All models of the Serial Device Interface use the same Serial Device Interface FTA assembly. The firmware that is resident in the FTA’s plug-in module, M1, determines the selected serial communications interface type (EIA-232 or EIA-422/485) and the interface application. The FTA is assigned a unique FTA model number depending upon the user’s application.

EIA-232 and EIA-422/485 interfaces

The Serial Device Interface FTA has both EIA-232 (RS-232) and EIA-422/485 (RS-422/485) asynchronous serial communications interfaces, one of which is active depending on the FTA model number, using either a DB-25 or a 5-terminal compression terminal connector, respectively. The model MU-TSDT02 FTA supports the EIA-232 interface, and the model MU-TSDM02 and MU-TSDU02 FTAs support the EIA-422/485 interface.

Continued on next page

13.2 Serial Device Interface Configurations, Continued

SDI interface configuration

Figure 13-1 illustrates a typical Serial Device Interface configuration.

Figure 13-1 Serial Device Interface Interconnections

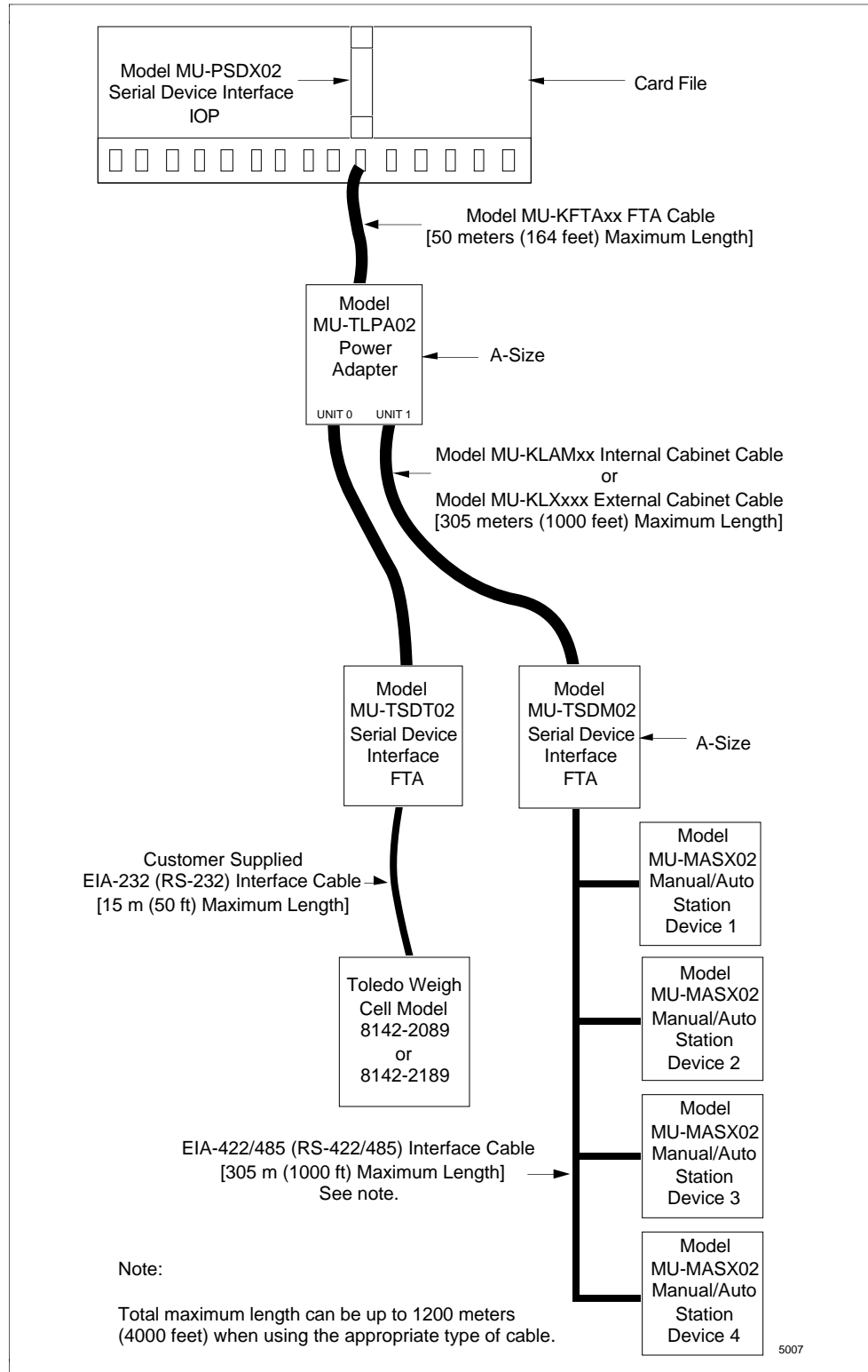

Continued on next page

13.2 Serial Device Interface Configurations, Continued

EIA-232 cable length limitation

The EIA-232 cable is limited to a distance of 15 meters (50 feet). The cable must be supplied by the user and terminate in a DB-25 connector.

ATTENTION

ATTENTION—The EIA-232 interface is a point-to-point interface in which only one serial device can be connected. The EIA-422/485 interface can be configured as a multidrop interface on which up to 15 serial devices can be connected.

13.3 Serial Device Interface IOP Placement

Locating the IOP

The Serial Device Interface IOP can be installed in any available card file slot.

13.4 Power Adapter Placement

Install within 50 meters of IOP

The Power Adapter can be installed on any available FTA Mounting Channel that is within 50 meters (164 feet) of the Serial Device Interface IOP.

Power Adapter size

The Power Adapter has the same dimensions as an A-size (6 inches) FTA.

13.5 IOP to Power Adapter Cabling

Non-CE-Compliant IOP to Power Adapter cabling

The interconnection between the IOP and the Power Adapter is provided by a model MU-KFTAxx cable. The cable is used in non-CE Compliant applications. The suffix “xx” in the model number represents the length of the cable in meters. The cable is available in 12 lengths, up to 50 meters (164 feet). See the *Process Manager/Advanced Process Manager Service* manual for the exact lengths that are available.

CE-Compliant IOP to Power Adapter cabling

Presently, the Serial Device Interface FTA cannot be used for CE Compliant application.

13.6 Serial Device Interface FTA Placement

Install within 305 meters of Power Adapter The Serial Device Interface FTA can be installed in the same Process Manager or Advanced Process Manager cabinet as the Serial Device Interface IOP, or remotely, up to 305 meters (1000 feet) from the Power Adapter.

FTA size The FTA is an A-size (6 inches) FTA and can be installed on an FTA Mounting Channel.

13.7 FTA to Power Adapter Cabling

FTA to Power Adapter cable The cable connecting the Serial Device Interface FTA to the Power Adapter is a shielded twisted pair cable that is supplied by Honeywell. Two types of cables are available, an internal cabinet cable, model MU-KLAMxx, and an external cabinet cable, model MU-KLXxxx.

The suffix “xx” represents the length of the cable in centimeters for the model MU-KLAMxx cable. Five lengths are available, 30, 66, 100, 200, and 300 centimeters.

The suffix “xxx” represents the length of the cable in meters for the model MU-KLXxxx cable. Three lengths are available, 76, 152, and 305 meters.

Internal cabinet or cabinet complex cabling When the Serial Device Interface FTA is installed in the same cabinet, or cabinet complex, as the Power Adapter, a model MU-KLAMxx cable with stripped wire ends is used for the interconnection. See the *Process Manager/Advanced Process Manager Service* manual for available cable lengths.

The cable has two individually shielded, twisted-pair wires. The shields must be connected to ground at the Power Adapter end only. The wire connections are made by using the compression terminals in a 6-pin connector at the Power Adapter end and a in 4-pin connector at the Serial Device Interface FTA end.

Continued on next page

13.7 FTA to Power Adapter Cabling, Continued

External cabinet cabling When the Serial Device Interface FTA is installed remotely from the Power Adapter, a model MU-KLXxxx cable is used for the interconnection. See the *Process Manager/Advanced Process Manager Service* manual for available cable lengths.

The cable has a braided shield with twisted-pair wires. The shields must be connected to ground at both Power Adapter end and the FTA end of the cable. The wire connections are made by using the compression terminals in a 6-pin connector at the Power Adapter end and in a 4-pin connector at the Serial Device Interface FTA end.

References For additional Serial Device Interface IOP and FTA information, see the *Process Manager I/O Installation* or *Process Manager/Advanced Process Manager Service* manual.

Power Adapter to FTA cable specifications The model MU-KLAMxx (internal) and model MU-KLXxxx (external) cables have the following specifications.

**Model MU-KLAMxx
cable
(Internal cabinet use)**

- Manufacturer Type—Belden 9406
 - Configuration—Shielded double pair
 - Flame Resistance Conformity—CSA FT4
 - CSA Type—CMG
 - NEC Type—CMG
-

**Model MU-KLXxxx
cable
(External cabinet use)**

- Manufacturer Type—Belden 83654
 - Configuration—Shielded double pair (TEFLON jacket)
 - Flame Resistance Conformity—CSA FT4/FT6 and UL910
 - CSA Type—CMP
 - NEC Type—CMP
 - Temperature Rating: -70°C to +200°C
-

13.8 FTA Field Cabling

FTA to field device cable specifications

The cables that follow are recommended as EIA-422/485 FTA to field device interface cables and have the following specifications. Honeywell offers the model MU-KSXxxx cable (three lengths – 76, 152, and 305 meters, the suffix “xxx” represents the length of the cable in meters). The other two recommended cable types can be purchased directly from the manufacturer.

All the cables are available in lengths up to 305 meters (1000 feet). The total combined length between the FTA and the field devices can be 1200 meters (4000 feet) for the Model MU-KSXxxx and Belden 9182 cables, and 305 meters (1000 feet) for the Belden 9271 cable.

Model MU-KSXxxx cable

- Manufacturer Type—Belden model 89182
 - Configuration—Shielded single pair (TEFLON jacket)
 - Flame Resistance Conformity—CSA FT4/FT6
 - CSA Type—CMP
 - NEC Type—CL2P and CMP (Plenum)
 - Temperature Rating: -70°C to +200°C
-

Belden 9182 cable

- Manufacturer Type—Belden model 9182
 - Cable Configuration—Shielded single pair
 - Flame Retardant
 - Flame Resistance Conformity—CSA FT1
 - CSA Type—CMX
 - NEC Type—CL2X and CMX
 - Temperature Rating: -20°C to +60°C
-

Belden 9271 cable

- Manufacturer Type—Belden model 9271
 - Cable Configuration—Shielded single pair
 - Flame Retardant
 - Flame Resistance Conformity—CSA FT1
 - CSA Type—CM
 - NEC Type—CM
 - Temperature Rating: -40°C to +80°C
-

13.9 Serial Device Interface FTA Models

Model MU-TSDT02

The model MU-TSDT02 Serial Device Interface FTA accommodates the model 8142-2084 or 8142-2184 Toledo Weigh Cell device, manufactured by Toledo Scale Inc., through its EIA-232 (RS-232) interface.

Model MU-TSDM02

The model MU-TSDM02 Serial Device Interface FTA accommodates up to four model MU-MASX02 Manual/Auto Station devices, manufactured by Honeywell Inc., through its EIA-422/485 (RS-422/485) interface.

Model MU-TSDU02

The model MU-TSDU02 Serial Device Interface FTA accommodates up to four model MU-MASX02 UDC 6000 devices, manufactured by Honeywell Inc., through its EIA-422/485 (RS-422/485) interface.

Section 14 – Serial Interface Planning

14.1 Overview

Section contents The topics covered in this section are:

	Topic	See Page
14.1	Overview.....	223
14.2	Serial Interface Configurations.....	223
14.3	Serial Interface IOP Placement.....	229
14.4	Power Adapter Placement.....	229
14.5	IOP to Power Adapter Cabling.....	229
14.6	Serial Interface FTA Placement.....	230
14.7	FTA to Power Adapter Cabling.....	230
14.8	FTA Field Cabling.....	232
14.9	Serial Interface FTA Models.....	233
14.10	Communications Interface Specifications.....	234

14.2 Serial Interface Configurations

CE Compliance

Some Serial Interface (SI) Field Termination Assemblies (FTAs) are CE Compliant, while others are not. The CE Compliant and non-CE Compliant models with their part numbers are listed in Table 14-1. CE Compliant SI assemblies are identified by the tab number of the part number that ends in “26” or “28.” They do not have a unique model number.

CE Compliant FTA assemblies have a FASTON terminal that is located at one corner of the FTA. It is secured by the FTA mounting screw and ensures a Safety Ground connection. The terminal is used only when the FTA is mounted at a remote location that is external to the cabinet or cabinet complex in which the Power Adapter is mounted.

For CE Compliant installations, if the Power Adapter is remotely mounted in a cabinet that is separate from the cabinet in which its associated IOP is mounted, it is mandatory that a model MU-KFTSxx shielded IOP to FTA cable be used between the assemblies.

Table 14-1 Serial Interface FTAs

Model Number	Non-CE Compliant Part Number	CE Compliant Part Number
MU-TSIM12	51303932-401	51303932-426
MU-TSIA12	51303932-403	51303932-428

Continued on next page

14.2 Serial Interface Configurations, Continued

Introduction	The model MU-TSIM12 or MU-TSIA12 Serial Interface (SI) FTA communicates with the model MU-PSIM11 Serial Interface IOP through the model MU-TLPA02 Power Adapter.
FTA plug-in module determines application	The firmware that is resident in the FTA's plug-in module, M1, identifies it as a Serial Interface FTA and determines the selected serial communications interface type (EIA-232 or EIA-422/485) and the interface application. The FTA is assigned a unique model number depending upon the application.
EIA-232 and EIA-422/485 interfaces	<p>The Serial Interface FTA has both EIA-232 (RS-232) and EIA-422/485 (RS-422/485) asynchronous serial communications interfaces, one of which is active depending on the software-selected application, using either a DB-25 or a 5-terminal compression-type connector, respectively.</p> <p>The EIA-232 cable is limited to a distance of 15 meters (50 feet). The cable must be supplied by the user and terminate in a DB-25 connector.</p>
ATTENTION	ATTENTION —The EIA-232 interface is a point-to-point interface on which only one serial device can be connected. The EIA-422/485 interface is configured as a multidrop interface on which up to fifteen serial devices can be connected.
Modbus protocol device	A Modbus protocol device that interfaces with the Serial Interface FTA must qualify as compatible though Honeywell's Multivendor Interface Program.

Continued on next page

14.2 Serial Interface Configurations, Continued

Non-CE Compliant model MU-TSIM12 FTA interconnections

Figure 14-1 illustrates a non-CE Compliant Serial Interface configuration incorporating the model MU-TSIM12 Serial Interface FTA.

Figure 14-1 Model MU-TSIM12 Serial Interface FTA Interconnections—Non-CE Compliant

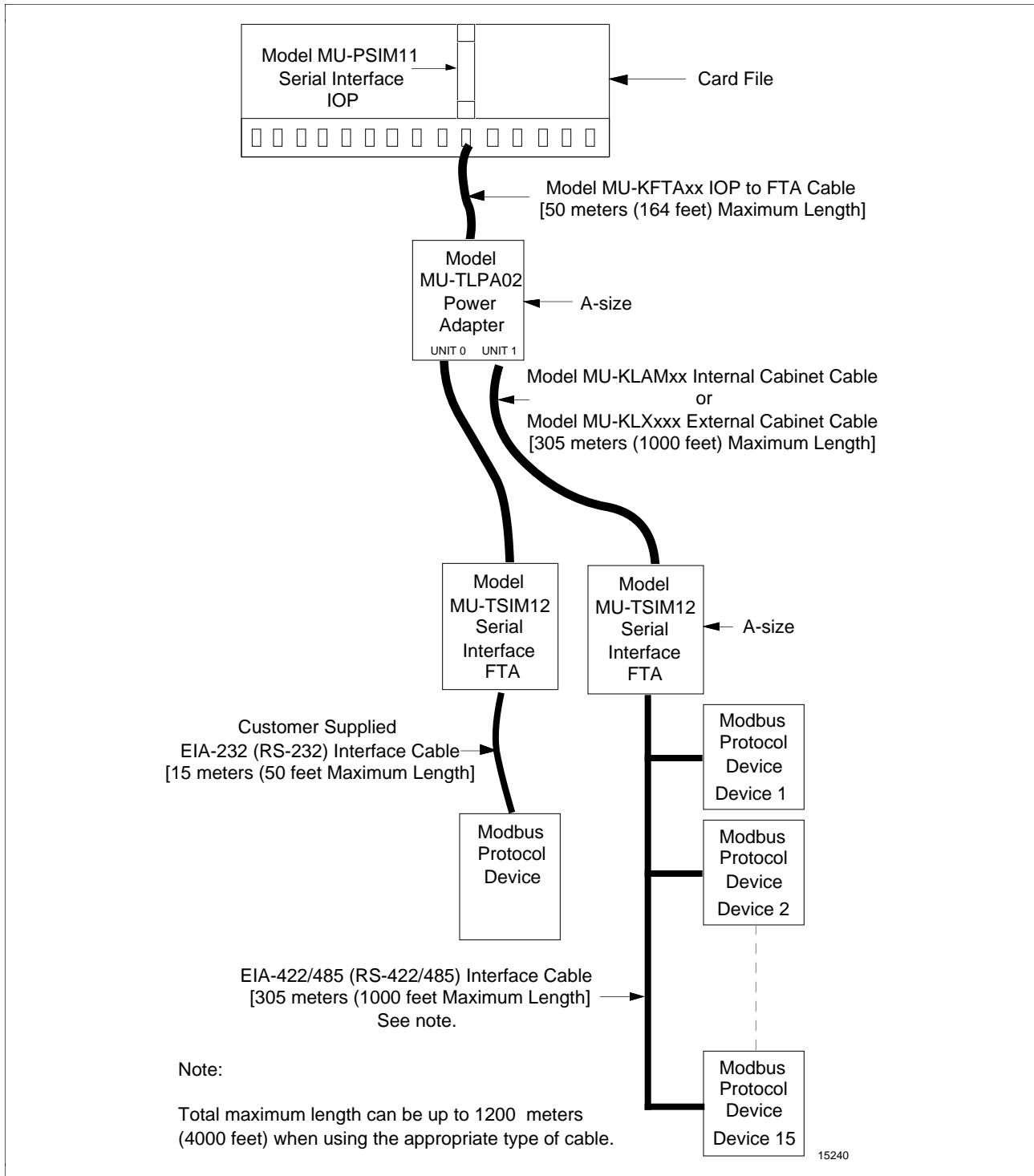

Continued on next page

14.2 Serial Interface Configurations, Continued

CE Compliant model MU-TSIM12 FTA interconnections

Figure 14-2 illustrates a CE Compliant Serial Interface configuration incorporating the model MU-TSIM12 Serial Interface FTA.

Figure 14-2 Model MU-TSIM12 Serial Interface FTA Interconnections—CE Compliant

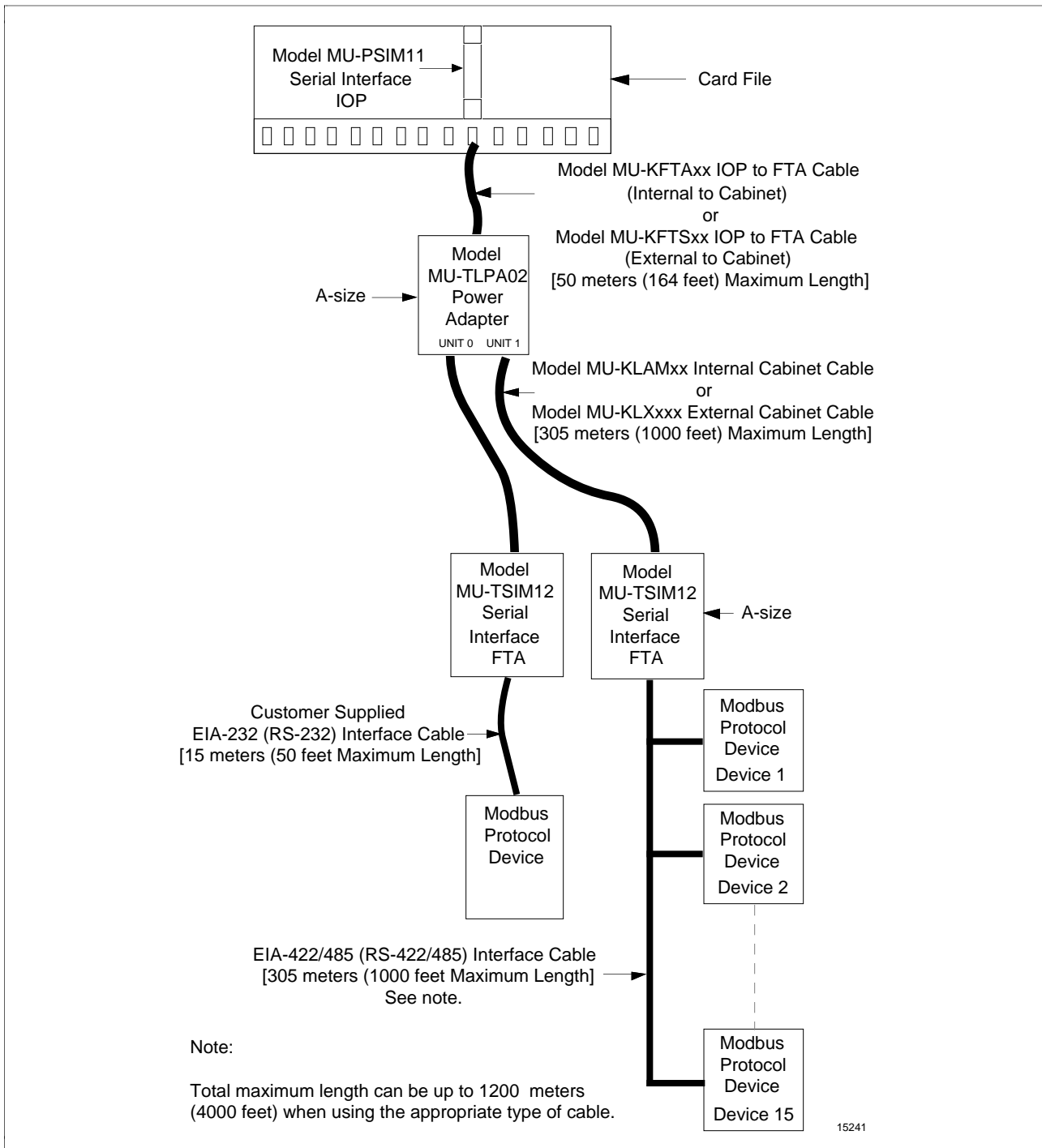

Continued on next page

14.2 Serial Interface Configurations, Continued

Non-CE Compliant model MU-TSIA12 FTA interconnections

Figure 14-3 illustrates a non-CE Compliant Serial Interface configuration incorporating the model MU-TSIA12 Serial Interface FTA.

Figure 14-3 Model MU-TSIA12 Serial Interface FTA Interconnections—Non-CE Compliant

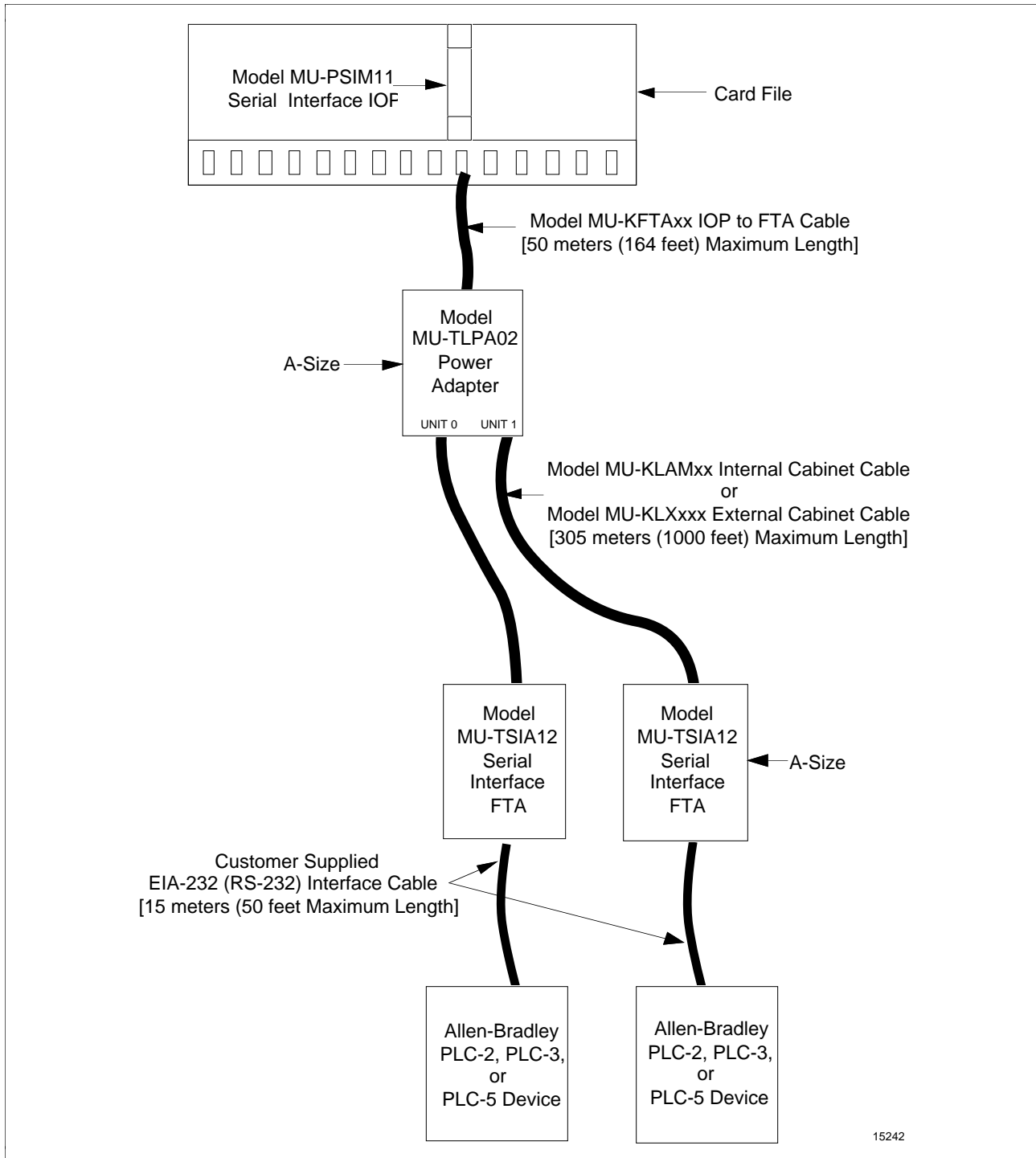

15242

Continued on next page

14.2 Serial Interface Configurations, Continued

CE Compliant model MU-TSIA12 FTA interconnections

Figure 14-4 illustrates a CE Compliant Serial Interface configuration incorporating the model MU-TSIA12 Serial Interface FTA.

Figure 14-4 Model MU-TSIA12 Serial Interface FTA Interconnections—CE Compliant

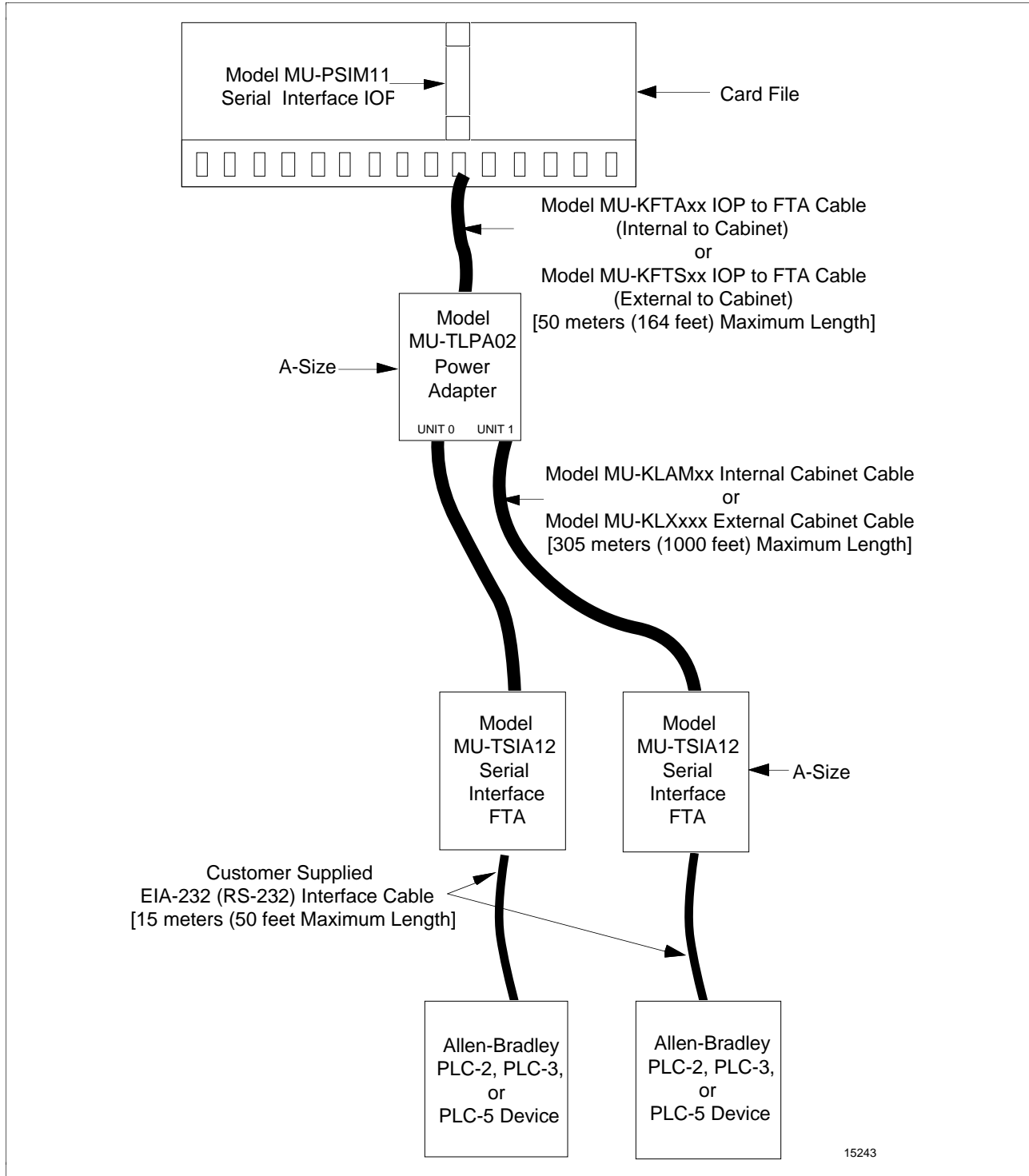

14.3 Serial Interface IOP Placement

Locating the IOP The Serial Interface IOP can be installed in any available card file slot.

14.4 Power Adapter Placement

Install within 50 meters of IOP The Power Adapter can be installed on any available FTA Mounting Channel that is within 50 meters (164 feet) of the Serial Interface IOP.

Power Adapter size The Power Adapter has the same dimensions as an A-size (6 inches) FTA.

14.5 IOP to Power Adapter Cabling

Non-CE Compliance IOP to Power Adapter cabling The interconnection between the IOP and the Power Adapter is provided by a model MU-KFTAxx cable. The cable is used in non-CE Compliant applications. The suffix “xx” in the model number represents the length of the cable in meters. The cable is available in 12 lengths, up to 50 meters (164 feet). See the *Process Manager/Advanced Process Manager Service* manual for the exact lengths that are available.

CE Compliance IOP to Power Adapter cabling The interconnection between the IOP and the Power Adapter for a CE Compliant application is provided by a model MU-KFTSxx shielded cable. The suffix “xx” represents the length of the cable in meters. The cable is available in 12 lengths, up to 50 meters (164 feet). See the *Process Manager/Advanced Process Manager Service* manual for the exact lengths that are available.

If the IOP and Power Adapter are located in the same cabinet, or a cabinet complex, the model MU-KFTAxx unshielded IOP to FTA cable can be used instead of the shielded model MU-KFTSxx IOP to FTA cable. See Figure 14-2 or 14-4.

14.6 Serial Interface FTA Placement

Install within 305 meters of Power Adapter The Serial Interface FTA can be installed in the same cabinet as the Power Adapter, or remotely, up to 305 meters (1000 feet) from the Power Adapter.

FTA size The FTA is an A-size (6 inches) FTA and is generally installed on an FTA Mounting Channel.

14.7 FTA to Power Adapter Cabling

FTA to Power Adapter cable The cable connecting the Serial Interface FTA to the Power Adapter is a shielded twisted-pair cable that is supplied by Honeywell. Two types of cables are available, an internal cabinet cable, model MU-KLAMxx, and an external cabinet cable, model MU-KLXxxx.

The suffix “xx” represents the length of the cable in centimeters for the model MU-KLAMxx cable. Five lengths are available, 30, 66, 100, 200, and 300 centimeters.

The suffix “xxx” represents the length of the cable in meters for the model MU-KLXxxx cable. Three lengths are available, 76, 152, and 305 meters.

Internal cabinet or cabinet complex cabling When the Serial Interface FTA is installed in the same cabinet, or cabinet complex, as the Power Adapter, a model MU-KLAMxx cable with stripped wire ends is used for the interconnection. See the *Process Manager/Advanced Process Manager Service* manual for available cable lengths.

The cable has two individually shielded, twisted-pair wires. The shields must be connected to ground at the Power Adapter end only. The wire connections are made by using the compression terminals in a 6-pin connector at the Power Adapter end and a 4-pin connector at the Serial Device Interface FTA end.

Continued on next page

14.7 FTA to Power Adapter Cabling, Continued

External cabinet cabling When the Serial Interface FTA is installed remotely from the Power Adapter, a model MU-KLXxxx cable is used for the interconnection. See the *Process Manager/Advanced Process Manager Service* manual for available cable lengths.

The cable has a braided shield with twisted-pair wires. The shields must be connected to ground at both the Power Adapter end and the FTA end of the cable. The wire connections are made by using the compression terminals in a 6-pin connector at the Power Adapter end and in a 4-pin connector at the Serial Interface FTA end.

References For additional Serial Interface IOP and FTA information, see the *Process Manager I/O Installation* or *Process Manager/Advanced Process Manager Service* manual.

Power Adapter to FTA cable specifications The model MU-KLAMxx (internal) and model MU-KLXxxx (external) cables have the following specifications.

**Model MU-KLAMxx
cable
(Internal cabinet use)**

- Manufacturer Type—Belden 9406
 - Configuration—Shielded double pair
 - Flame Resistance Conformity—CSA FT4
 - CSA Type—CMG
 - NEC Type—CMG
-

**Model MU-KLXxxx
cable
(External cabinet use)**

- Manufacturer Type—Belden 83654
 - Configuration—Shielded double pair (TEFLON jacket)
 - Flame Resistance Conformity—CSA FT4/FT6 and UL910
 - CSA Type—CMP
 - NEC Type—CMP
 - Temperature Rating: -70°C to +200°C
-

Continued on next page

14.8 FTA Field Cabling

FTA to field device cable specifications

The cables that follow are recommended as EIA-422/485 FTA to field device interface cables and have the listed specifications. Honeywell offers the model MU-KSXxxx cable (three lengths – 76, 152, and 305 meters, the suffix “xxx” represents the length of the cable in meters). The other two recommended cable types can be purchased directly from the manufacturer.

All the cables are available in lengths up to 305 meters (1000 feet). The total combined length between the FTA and the field devices can be 1200 meters (4000 feet) for the model MU-KSXxxx and Belden model 9182 cables, and 305 meters (1000 feet) for the Belden model 9271 cable.

Model MU-KSXxxx cable

- Manufacturer Type—Belden model 89182
 - Configuration—Shielded single pair (TEFLON jacket)
 - Flame Resistance Conformity—CSA FT4/FT6
 - CSA Type—CMP
 - NEC Type—CL2P and CMP (Plenum)
 - Temperature Rating: -70°C to +200°C
-

Belden 9182 cable

- Manufacturer Type—Belden model 9182
 - Cable Configuration—Shielded single pair
 - Flame Retardant
 - Flame Resistance Conformity—CSA FT1
 - CSA Type—CMX
 - NEC Type—CL2X and CMX
 - Temperature Rating: -20°C to +60°C
-

Belden 9271 cable

- Manufacturer Type—Belden model 9271
 - Cable Configuration—Shielded single pair
 - Flame Retardant
 - Flame Resistance Conformity—CSA FT1
 - CSA Type—CM
 - NEC Type—CM
 - Temperature Rating: -40°C to +80°C
-

14.9 Serial Interface FTA Models

Model MU-TSIM12 Interface configurations

By configuration, the Honeywell model MU-TSIM12 Serial Interface FTA will accommodate either a single EIA-232 Modbus compatible device through its EIA-232 interface, or up to 15 EIA-422/485 Modbus compatible devices through its EIA-422/485 interface.

Model MU-TSIM12 Modbus protocol

The type of device that interfaces the model MU-TSIM12 Serial Interface FTA must be compatible with Modbus RTU protocol. When the EIA-422/485 interface is active, the subsystem performance is dependent upon the number of devices, their baud rate, the number of transactions, and the FTA device driver firmware.

Model MU-TSIA12 Allen-Bradley device

The model MU-TSIA12 Serial Interface FTA accommodates a single EIA-232 compatible Allen-Bradley device through its EIA-232 interface.

14.10 Communications Interface Specifications

Specifications

The EIA-232 or EIA-422/485 interface is configurable for baud rates of 1200, 2400, 4800, 9600, or 19200 with odd, even or no parity, and one stop bit. The default setting is 19200 baud, odd parity with one stop bit.

Table 14-2 lists the EIA-232 interface specifications, while Table 14-3 lists the EIA-422/485 interface specifications.

Table 14-2 Serial Interface EIA-232 Specifications

Description	Specification
Interface Type	Asynchronous serial data
Interface Signals Supported	TXD, RXD, RTS, CTS, DSR, DTR, DCD, logic ground, chassis ground.
Interface Length	15 meters (maximum cable capacitance of 2500 pF)

Table 14-3 Serial Interface EIA-422/485 Specifications

Description	Specification
Interface Type	Asynchronous half-duplex serial data
Interface Signals Supported	Two-wire differential pair (Terminals A and B) and shield connections
Interface Length	305 meters (up to 1220 meters with Honeywell approved cable)
Number of Devices	15 maximum

Reference

Refer to the *Process Manager I/O Specifications and Technical Data* manual for additional information.

Section 15 – Galvanically Isolated FTA Planning

15.1 Overview

Section contents The topics covered in this section are:

Topic	See Page
15.1 Overview.....	235
15.2 Description.....	237
15.3 Features	244
15.3.1 IOP Redundancy.....	244
15.3.2 Analog and Digital Output Standby Manual Devices	244
15.3.3 Auxiliary Inputs/Outputs.....	245
15.3.4 Power Requirements.....	247
15.3.5 Field Wiring Connections	248
15.3.6 Ambient Temperature Limits.....	248
15.3.7 FTA Mounting Channels	249
15.4 Power Distribution	253
15.4.1 Power Distribution Assembly.....	254
15.4.2 Cabling to Power Distribution Assemblies.....	255
15.4.3 Cabling to FTAs.....	255
15.4.4 Power Considerations.....	256
15.5 High Level Analog Input (HLAI) FTAs	257
15.5.1 Model MU-GAIH12/MU-GAIH82 FTA	257
15.5.1.1 Description.....	257
15.5.1.2 Connectors.....	257
15.5.1.3 Field Wiring Input Signals	257
15.5.1.4 Auxiliary Connector Output	258
15.5.1.5 Indicators	258
15.5.1.6 Current Consumption	258
15.5.1.7 Isolation and Safety.....	258
15.5.2 Model MU-GAIH13/MU-GAIH83 FTA	259
15.5.2.1 Description.....	259
15.5.2.2 Connectors.....	259
15.5.2.3 Field Wiring Input Signals	260
15.5.2.4 Auxiliary Connector Output	260
15.5.2.5 Indicators	260
15.5.2.6 Hand-Held Communicator	261
15.5.2.7 Current Consumption	261
15.5.2.8 Isolation and Safety.....	261
15.5.3 Model MU-GAIH14/MU-GAIH84 FTA	262
15.5.3.1 Description.....	262
15.5.3.2 Connectors.....	262
15.5.3.3 Field Wiring Input Signals	263
15.5.3.4 Auxiliary Connector Output	263
15.5.3.5 Indicators	263
15.5.3.6 Hand-Held Communicator	264
15.5.3.7 Current Consumption	264
15.5.3.8 Isolation and Safety.....	264
15.5.4 Model MU-GAIH22/MU-GAIH92 FTA	265
15.5.4.1 Description.....	265
15.5.4.2 Connectors.....	265

Continued on next page

15.1 Overview, Continued

Section contents,
continued

	Topic	See Page
15.5.4.3	Field Wiring Input Signals	266
15.5.4.4	Auxiliary Connector Output	266
15.5.4.5	Indicators	266
15.5.4.6	Current Consumption	267
15.5.4.7	Isolation and Safety.....	267
15.6	24 Vdc Digital Input FTAs	268
15.6.1	Model MU-GDID12/MU-GDID82 FTA	268
15.6.1.1	Description.....	268
15.6.1.2	Connectors.....	268
15.6.1.3	Field Wiring Input Signals	269
15.6.1.4	Line-Fault Detection	269
15.6.1.5	Auxiliary Connector Output	269
15.6.1.6	Indicators	270
15.6.1.7	Current Consumption	270
15.6.1.8	Isolation and Safety.....	270
15.6.2	Model MU-GDID13/MU-GDID83 FTA	271
15.6.2.1	Description.....	271
15.6.2.2	Connectors.....	271
15.6.2.3	Field Wiring Input Signals	271
15.6.2.4	Indicators	272
15.6.2.5	Current Consumption	272
15.6.2.6	Isolation and Safety.....	272
15.7	Analog Output FTAs.....	273
15.7.1	Model MU-GAOX02/72 and MU-GAOX12/82 FTAs	273
15.7.1.1	Description.....	273
15.7.1.2	Connectors.....	273
15.7.1.3	Field Wiring Output Signals	273
15.7.1.4	Line-Fault Detection	274
15.7.1.5	Calibration.....	274
15.7.1.6	Indicators	274
15.7.1.7	Current Consumption	274
15.7.1.8	Isolation and Safety.....	275
15.8	24 Vdc Digital Output FTAs	276
15.8.1	Model MU-GDOD12/MU-GDOD82 FTA	276
15.8.1.1	Description.....	276
15.8.1.2	Signal Connectors.....	276
15.8.1.3	Field Wiring Output Signals	276
15.8.1.4	Auxiliary Connector.....	277
15.8.1.5	Indicators	277
15.8.1.6	Standby Manual Device Connector.....	277
15.8.1.7	Current Consumption	278
15.8.1.8	Isolation and Safety.....	278
15.8.2	Model MU-GDOL12/MU-GDOL82 FTA	279
15.8.2.1	Description.....	279
15.8.2.2	Signal Connectors.....	279
15.8.2.3	Field Wiring Output Signals	279
15.8.2.4	Auxiliary Connector.....	280
15.8.2.5	Indicators	280

Continued on next page

15.1 Overview, Continued

Section contents, continued

	Topic	See Page
15.8.2.6	Standby Manual Device Connector.....	281
15.8.2.7	Current Consumption.....	281
15.8.2.8	Isolation and Safety.....	281
15.9	Combiner Panel.....	282
15.10	Marshalling Panel.....	283
15.10.1	Description.....	283
15.10.2	Configurations.....	284
15.10.2.1	High Level Analog Input FTAs.....	284
15.10.2.2	Digital Input FTAs.....	285
15.10.2.3	Digital Output FTAs.....	286

Introduction This section will assist you in planning the installation of Galvanically Isolated FTAs and suggest ways to take advantage of the hardware's versatility.

Installation references Additional information concerning the FTAs can be found in the *Process Manager I/O Installation* manual and the *Process Manager I/O Specification and Technical Data* manual.

15.2 Description

Introduction A family of Field Termination Assemblies (FTAs) is available that accept plug-in Galvanic Isolation Modules. These FTAs are used for connecting input and output signals to field devices in Division 1 (Zone 0 and Zone 1) hazardous areas. The FTAs are compatible with the IOPs that support the companion standard FTAs.

Usage advantages The isolating nature of the intrinsically safe connection removes the necessity to install a potential-equalizing conductor where it is called for in any certification. The resultant simplification and reduction in cost of the installation is a considerable advantage and makes the use of the Galvanic Isolators, the preferred method over conventional shunt-diode safety barriers for this type of installation. There are many occasions when the lack of information about the precise site conditions is solved by using the isolators to minimize installation and security problems.

Continued on next page

15.2 Description, Continued

CE Compliance

Some Galvanically Isolated Field Termination Assemblies and their supporting assemblies, such as a Combiner Panel, are CE Compliant, while others are not CE Compliant. The CE Compliant and non-CE Compliant models with their part numbers are listed in Table 15-1. Generally, CE Compliant Galvanically Isolated assemblies are identified by the tab number of the part number that ends in “25.” They do not have a unique model number.

The CE Compliant FTAs feature filtered connectors that interface with the CE Compliant model MU-KFTSxx IOP to FTA cable(s).

Table 15-1 CE Compliant Galvanically Isolated FTAs

Model Number	Non-CE Compliant Part Number	CE Compliant Part Number
MU-GAIH12	51304636-100	N/A
MU-GAIH13	51304718-100	51304718-125
MU-GAIH14	51304730-100	51304730-125
MU-GAIH22	51304748-100	51304748-125
MU-GAIH82	51304636-300	N/A
MU-GAIH83	51304718-300	51304718-325
MU-GAIH84	51304730-300	51304730-325
MU-GAIH92	51304748-300	51304748-325
MU-GAOX02	51304638-100	51304638-125
MU-GAOX12	51304638-500	51304638-525
MU-GAOX72	51304638-300	51304638-325
MU-GAOX82	51304638-700	51304638-725
MU-GDID12	51304640-100	51304640-125
MU-GDID13	51304728-100	51304728-125
MU-GDID82	51304640-300	51304640-325
MU-GDID83	51304728-300	51304728-325
MU-GDOD12	51304642-100	51304642-125
MU-GDOD82	51304642-300	51304642-325
MU-GDOL12	51304736-100	51304736-125
MU-GDOL82	51304736-300	51304736-325

Continued on next page

15.2 Description, Continued

CE Compliance, continued

Table 15-1 CE Compliant Galvanically Isolated FTAs, Continued

Model Number	Non-CE Compliant Part Number	CE Compliant Part Number
MU-GPRD02	51304644-100	51304644-125
MU-GLFD02	51304732-100	51304732-125
MU-GMAR52	51304646-100	51309156-125

FTA mounting

All the FTA assemblies are approximately 309 by 124 millimeters (12 by 4.9 inches), which is a B-size FTA classification for mounting. The FTAs are installed on a model MU-TMHN01 or MU-TMHN02 FTA Mounting Channels that are horizontally positioned in the cabinet. Figure 15-1 is an illustration of a typical Galvanically Isolated FTA.

Figure 15-1 Typical Galvanically Isolated FTA

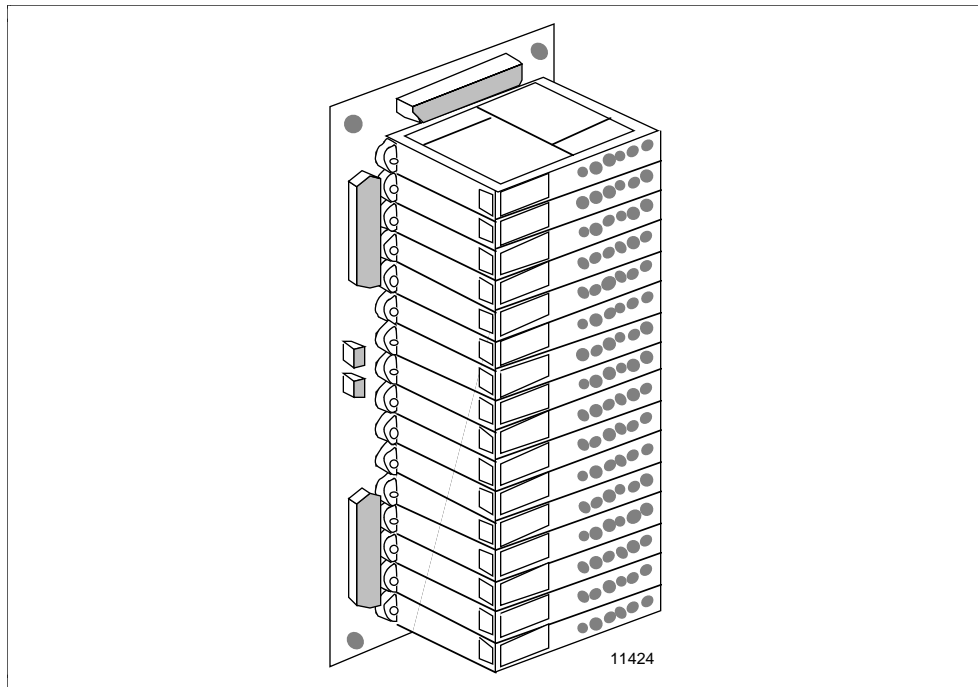

FTA to IOP cable

A 50-pin FTA to IOP cable, model MU-KFTAxx (the suffix “xx” represents the length of the cable in meters), is used to connect non-CE Compliant FTAs to their associated IOP(s). The model MU-KFTSxx IOP to FTA cable is a shielded cable that is used to connect CE Compliant FTAs to their IOP(s) when the cable leaves the cabinet.

Continued on next page

15.2 Description, Continued

Galvanic Isolation Module

Field signal connections are made at the plug-in Galvanic Isolation Module on the FTA. In general, each module provides a terminal connector for one field device connection. The exception is the Galvanic Isolation Module on the Digital Input FTA. This Galvanic Isolation Module provides terminal connectors for two field devices. Figure 15-2 is an illustration of the Galvanic Isolation Module and its mounting orientation on the FTA.

Figure 15-2 Galvanic Isolation Module

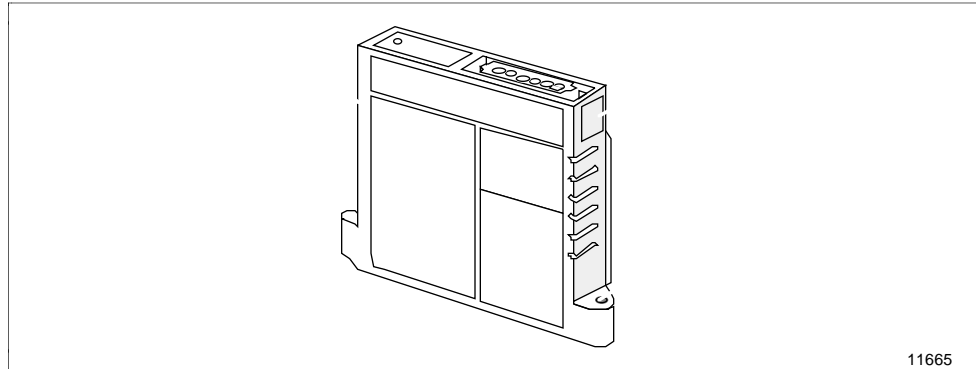

11665

Compression or crimp terminal connectors

Compression-type or crimp-type pluggable 6-terminal connectors can be specified for the Galvanic Isolation Modules. The model number for the FTA specifies the connector type. If the model number ends in 02, 12, 13, 14, or 22, such as MU-GAOX02, MU-GAIH12, MU-GAIH13, MU-GAIH14, or MU-GAIH22, compression-type terminal connectors are provided. If the model number ends in 72, 82, 83, 84, or 92, such as MU-GAOX72, MU-GAIH82, MU-GAIH83, MU-GAIH84, or MU-GAIH92, crimp-type terminal connectors are provided.

Continued on next page

15.2 Description, Continued

Crimp-type terminal connectors

The crimp-type of terminal connector accepts size 0.5 to 2.5 mm² (14 to 20 AWG) size field wiring. The crimp pin is installed over the end of the field wire that is stripped to a length of 4.0 millimeters with a crimp tool before its insertion into the terminal connector. The crimp tool is available in the model MU-GCTK01 Crimp Tool Kit.

The female crimp pin, with the attached field wire, mates with the Galvanic Isolation Module's connector pin, one of six. Figure 15-3 illustrates this procedure.

Figure 15-3 Crimp-Type Galvanic Isolation Module Terminal Connector

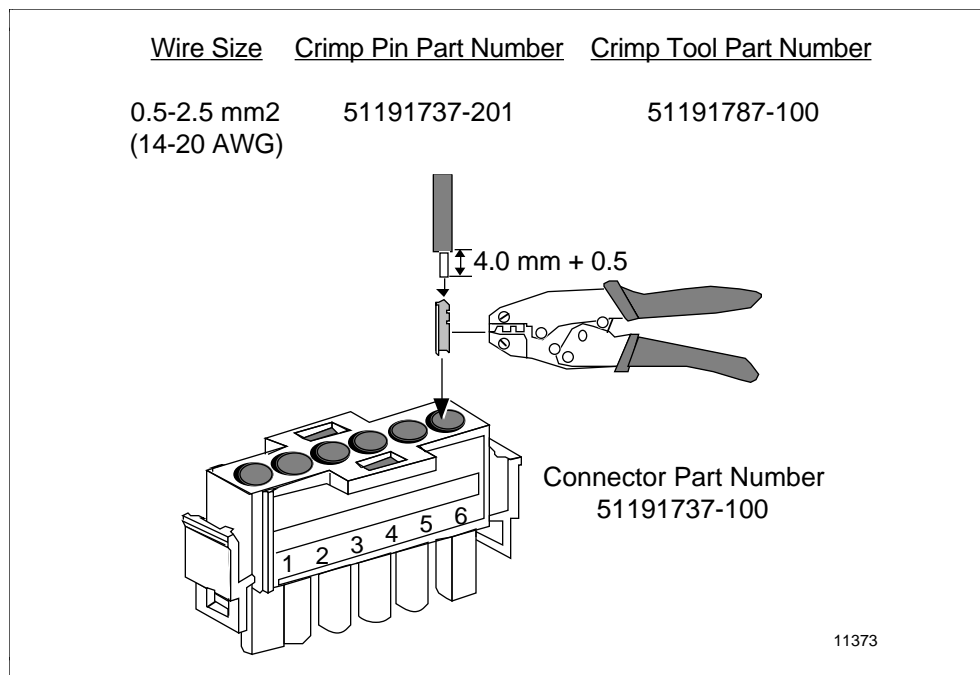

Continued on next page

15.2 Description, Continued

Compression-type terminal connectors

The compression-type of terminal connector accepts size 0.3 to 3.5 mm² (12 to 22 AWG) size field wiring. The end of the field wire is stripped to a length of 8.0 millimeters (0.3 inches), inserted into the proper terminal position, one of six, and secured in place by the tightening of a dedicated screw. Figure 15-4 illustrates this procedure. The terminal connector itself provides the pins that mate with the Galvanic Isolation Module's connector pins.

Figure 15-4 Compression-Type Galvanic Isolation Module Terminal Connector

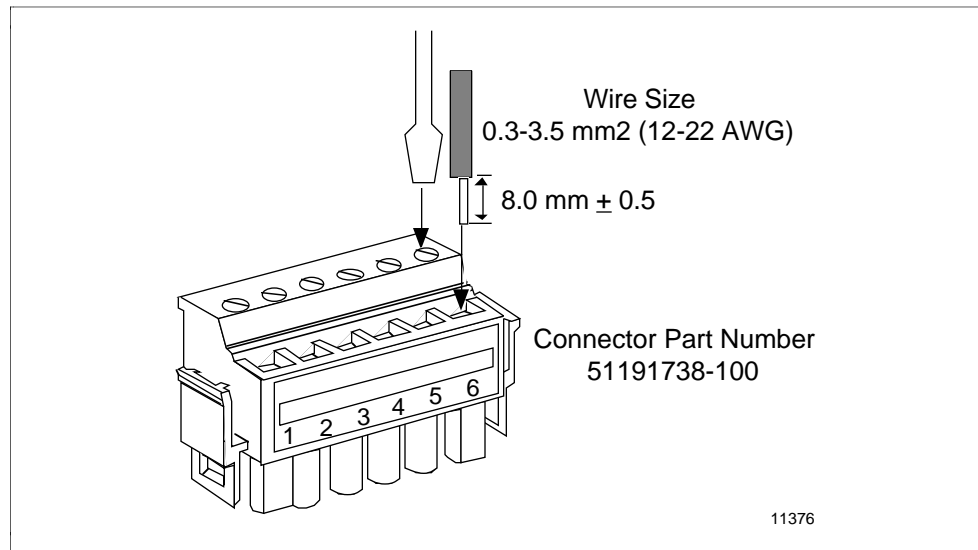

Continued on next page

15.2 Description, Continued

Types of FTAs

Numerous types of Galvanically Isolated FTAs are available. They are

- High Level Analog Input (HLAI), models MU-GAIH12 and MU-GAIH82, with voltage outputs to both the IOP and an auxiliary connector
 - High Level Analog Input /Smart Transmitter Interface (HLAI/STI), models MU-GAIH13 and MU-GAIH83, with voltage outputs to both the IOP and an auxiliary connector
 - High Level Analog Input /Smart Transmitter Interface (HLAI/STI), models MU-GAIH14 and MU-GAIH84, with higher loop resistance capability and voltage output to both the IOP and an auxiliary connector
 - High Level Analog Input (HLAI), models MU-GAIH22 and MU-GAIH92, with voltage outputs to the IOP and current outputs to an auxiliary connector
 - 24 Vdc Digital Input (DI), models MU-GDID12 and MU-GDID82, with relay outputs to the IOP and an auxiliary connector and Line Fault Detection in the IOP
 - 24 Vdc Digital Input (DI), models MU-GDID13 and MU-GDID83, with solid-state voltage outputs to the IOP and no auxiliary connector
 - Analog Output (AO), models MU-GAOX02, MU-GAOX12, MU-GAOX72, and MU-GAOX82 with Line Fault Detection in the IOP
 - Digital Output (DO), models MU-GDOD12 and MU-GDOD82, with 16 output override inputs from an auxiliary connector
 - Digital Output (DO), models MU-GDOL12 and MU-GDOL82 with Line Fault Detection outputs to an auxiliary connector
-

15.3 Features

Overview The subsections that follow describe the features that the Galvanically Isolated FTAs provide. Many of the features are standard FTA features.

15.3.1 IOP Redundancy

FTAs support redundancy Each type of FTA has two 50-pin FTA cable connectors that provide connections to two IOPs to support redundancy. A green LED on the FTA indicates which IOP has control when it is an output-type FTA or is active when it is an input-type FTA. The indicator identifies the primary IOP (A) FTA.

IOP redundancy support Only the High Level Analog Input, High Level Analog Input/Smart Transmitter Interface, and Analog Output-types of the FTAs have software available that supports IOP redundancy. The nonredundant models of the Analog Output FTA, models MU-GAOX02 and MU-GAOX72, cannot support IOP redundancy.

15.3.2 Analog and Digital Output Standby Manual Devices

Standby Manual Device connector A 50-pin connector on the Analog Output and 24 Vdc Digital Output FTAs accepts control signals from the Analog Standby Manual Device and Digital Output Standby Manual Device, respectively.

Analog Output FTA The Analog Output FTA has three 50-pin connectors. Two of the connectors are for redundant IOP connections, and a unique third connector is for connection to the Analog Output Standby Manual Device.

24 Vdc Digital Output FTA The 24 Vdc Digital Output FTA also has three 50-pin connectors. Two of the connectors provide connection to redundant IOPs, or like the standard 24 Vdc Digital Output FTA, connection to a Digital Output Standby Manual Device. The third connector supports auxiliary signals that are described in the following subsection.

15.3.3 Auxiliary Inputs/Outputs

HLAI/STI FTAs

In addition to the IOP redundancy connectors, the High Level Analog Input/Smart Transmitter Interface FTAs have an auxiliary connector that provides PV signals for recording or monitoring subsystems.

24 Vdc Digital Output FTAs

The model MU-GDOD12/82 24 Vdc Digital Output FTA has an auxiliary connector through which the user can provide signals from a shutdown subsystem to individually deenergize the FTA outputs. The model MU-GDOL12/82 Digital Output FTA provides Line Fault Detection (LFD) signals through the auxiliary connector.

24 Vdc Digital Input FTAs

The model MU-GDID12/82 24 Vdc Digital Input FTA has an auxiliary connector to provide signals that can be used to monitor the condition of the FTA's individual input contact sets. There are two sets of contacts per plug-in Galvanic Isolation Module. The contacts are isolated from the subsystem, but not from each other.

Continued on next page

15.3.3 Auxiliary Inputs/Outputs, Continued

Marshalling Panel

Access to the auxiliary signals is available at screw-type terminals on a Marshalling Panel that is connected by a 50-pin cable to the FTA's auxiliary connector. Figure 15-5 is an illustration of the connections between the Galvanically Isolated FTA, its associated IOP, and the Marshalling Panel.

Figure 15-5 Galvanically Isolated FTA with Auxiliary Connector

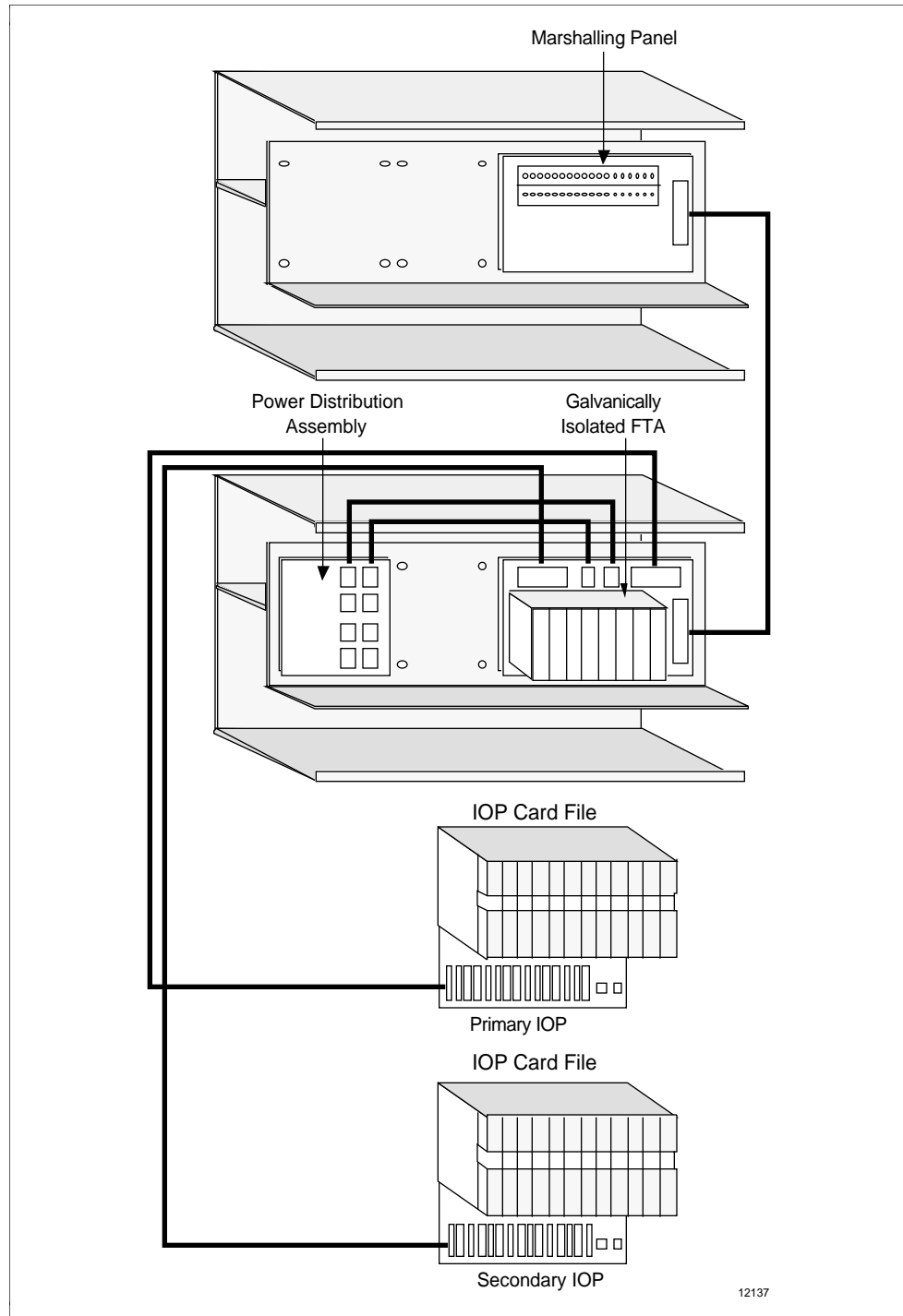

15.3.4 Power Requirements

Overview	The power requirement for the FTAs is a nominal 24 Vdc. Because of the large additional amount of power the Galvanically Isolated FTAs require, power to the FTA is not provided directly from the Power System through the associated IOP, as it is for standard FTAs, but through a Power Distribution Assembly. The Power Distribution Assembly is discussed in subsection 15.4.1.
Dual power connectors	The FTAs have dual 2-pin power connectors for power redundancy. Power for the two connectors can be provided by a single power source or separate power sources. Diodes on the FTA that “or” the two power sources prevent the two power sources from shorting together.
Galvanic Isolation Module fuses	Each Galvanic Isolation Module is internally fused. The fuse cannot be replaced in the field.
Power Distribution Assembly fuses	Fuses provided on the Power Distribution Assembly can be replaced in the field.
FTA fuses	Fuses provided on the FTA assembly can be replaced in the field.
FTA power requirements	Table 15-2 is a listing of the power requirements at 24 Vdc for the types of Galvanically Isolated FTAs that assumes all inputs/outputs are active.

Table 15-2 Galvanically Isolated FTA Power Requirements

FTA Type	Power Requirement (Amperes)
High Level Analog Input/Smart Transmitter Interface	
MU-GAIH12/82	1.28
MU-GAIH13/83	1.28
MU-GAIH14/84	1.20
MU-GAIH22/92	1.20
Analog Output	
MU-GAOX02/12/72/82	0.45
24 Vdc Digital Input	
MU-GDID12/82	0.72
MU-GDID13/83	0.56
24 Vdc Digital Output	
MU-GDOD12/82	1.10
MU-GDOL12/82	1.10

15.3.5 Field Wiring Connections

Location of terminal connectors	The FTAs do not have field terminal connectors mounted directly on the assembly's printed circuit board as the standard FTAs do, instead, field wires are connected to crimp-type or screw-type connectors on the individual Galvanic Isolation Module. The connectors accommodate 0.3 to 3.5 mm ² (12 to 22 AWG) size wiring when not using crimp pins on the wiring ends; 0.5 to 2.5 mm ² (14 to 20 AWG) size wiring when crimp pins are used.
Prewiring	The FTAs and their Galvanic Isolation Modules can be in place during the installation of the field wiring, but it is not necessary because of the connector's plug-in capability.
Galvanic Isolation Module replacement	A failed Galvanic Isolation Module can be replaced simply by unplugging the field wire connector on the module, then removing and replacing the module. The individual wires do not have to be disconnected.
Horizontal Bus Bar	Spare wires and cable shields are terminated in the normal manner. Because the FTA does not have a built-in shield bus, the accommodation of a large number of shield wires requires the use of a Horizontal Bus Bar that is part of the model MU-TMHN02 FTA Mounting Channel and connected to the local Master Reference Ground (Safety Ground for CE Compliance).

15.3.6 Ambient Temperature Limits

Operation limits	The ambient temperature limits of the Galvanic Isolation Modules are -20 to +60 degrees centigrade (working) and -40 to +80 degrees centigrade (storage). The humidity limits are 5 to 95% relative humidity.
-------------------------	---

15.3.7 FTA Mounting Channels

Overview

Standard FTAs always mount on 92-centimeter (36-inch) long FTA Mounting Channels that are installed vertically in the Process Manager or Advanced Processor Manager cabinet. Galvanically Isolated FTAs must always mount on 61-centimeter (24-inch) long FTA Mounting Channels that are installed horizontally in the cabinet to provide better cooling for the FTAs.

FTA Mounting Channel installation

Up to eight FTA Mounting Channels can be installed in a cabinet with a 6-millimeter (.25-inch) gap between them to accommodate the use of cable ties as necessary.

The FTA Mounting Channel is installed with the field wiring channel (trough) toward the bottom of the cabinet. The channel (trough) that contains the cables that connect the FTA to its associated IOP(s), the Power Distribution Assembly, and the Marshalling Panel or Combiner Panel, if applicable, is toward the top of the cabinet.

One or two FTAs can be mounted on each FTA Mounting Channel.

Continued on next page

15.3.7 FTA Mounting Channels, Continued

Cabinet with Horizontal FTA Mounting Channels

Figure 15-6 is an illustration of a cabinet with horizontally installed FTA Mounting Channels.

Figure 15-6 Cabinet with Horizontally Installed FTA Mounting Channels

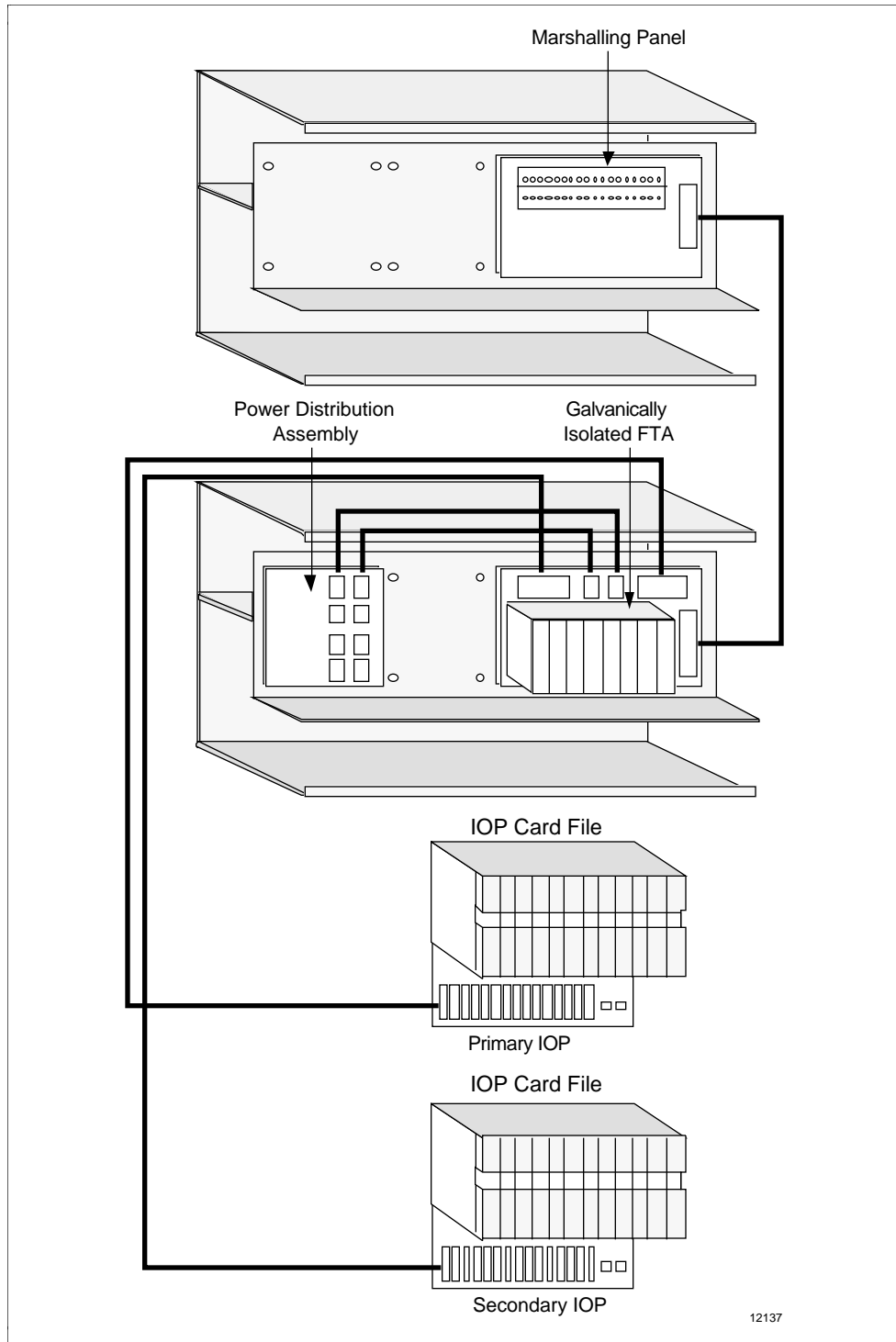

Continued on next page

15.3.7 FTA Mounting Channels, Continued

Mounting advantages

There are two reasons for mounting the FTAs on separate horizontally oriented FTA Mounting Channels.

- Installation of both Galvanically Isolated and standard FTAs on the same FTA Mounting Channel is not permitted. Both types of FTAs mounted on the same FTA Mounting Channel would be a safety violation.
- The design and current requirements of the Galvanic Isolation Modules is such that they operate cooler if they have a horizontal orientation.

Field wire routing

The field wires that connect to the FTA are routed to the right in the lower channel and out of the cabinet by going up or down the right side of the cabinet.

The field wires must be routed so that a minimum 2-inch separation is maintained between other wires or electrical components. The wiring can be separated from other wiring by a grounded metal divider or a nonconductive divider.

FTA cable routing

The cables that connect the FTA to its associated IOP(s), the Power Distribution Assembly, and the Marshalling Panel, if applicable, must be routed in the upper channel of the FTA Mounting Channel. The routing is to the left in the channel and up or down the left side of the cabinet.

Cabinet fan assembly requirements

Because of the increased heat dissipation requirements of Galvanically Isolated FTAs, cabinet fan assemblies are mandatory on both sides of a dual access cabinet. The single access cabinet also requires a cabinet fan assembly. FTA Mounting Channels must be installed only on the cabinet's center infrastructure and not at the sides of the cabinet.

Both FTA Mounting Channels types permitted

Although it is not permissible to mount standard FTAs and Galvanically Isolated FTAs on the same FTA Mounting Channel, it is permissible, but not preferable, to install both the vertical FTA Mounting Channels and the horizontal FTA Mounting Channels in the same cabinet.

If it is a requirement, up to three vertical FTA Mounting Channels can be installed in the lower portion of the cabinet, and up to three horizontal FTA Mounting Channels can be installed in the upper portion of the cabinet. A fourth horizontal FTA Mounting Channel is omitted, even though the space is available, to provide separation between the vertical and horizontal FTA Mounting Channels.

Continued on next page

15.3.7 FTA Mounting Channels, Continued

Marshalling Panel mounting

The model MU-GMAR52 Marshalling Panel can be mounted on either a horizontally or vertically installed FTA Mounting Channel. If it is mounted on a horizontally installed FTA Mounting Channel, no Galvanically Isolated FTAs can also be mounted on the FTA Mounting Channel. Cabling to the Marshalling Panel must be routed in the upper channel and to the left side of the cabinet.

Power Distribution Assembly mounting

The model MU-GPRD02 Power Distribution Assembly can be mounted on either a horizontally or vertically installed FTA Mounting Channel. If it is mounted on a horizontally installed FTA Mounting Channel and a Galvanically Isolated FTA is also mounted on the FTA Mounting Channel, the Power Distribution Assembly must be mounted at the left side of the FTA Mounting Channel with a 6-inch gap separating the assemblies.

Cabling to the Power Distribution Assembly must be routed in the upper channel and to the left side of the cabinet, except for the cables carrying power to an FTA mounted on the same FTA Mounting Channel.

Additional Power System

If an additional Power System is required in the cabinet to power the Galvanically Isolated FTAs, it can be installed on the same side of the cabinet as the FTA Mounting Channels. The Power System should be installed at the top of the cabinet if the FTA's field wiring entry is at the bottom of the cabinet, so the field wires are not routed near the Power System. If the field wiring entry is at the top of the cabinet, install the Power System at the bottom of the cabinet.

15.4 Power Distribution

Power Distribution Assembly

Galvanically Isolated FTAs use more 24 Vdc power than standard FTAs. Because of the increased demand, the Power Distribution Assembly, model MU-GPRD02, is used to supply power directly to the FTAs. (The power for a standard FTA is provided from the IOP through the cable that connects the IOP to the FTA.) The Power Distribution Assembly can be installed on the same FTA Mounting Channel as an FTA, but a spacing of at least 6 inches must exist between a Power Distribution Assembly and an FTA mounted on the same FTA Mounting Channel.

Power Distribution Assembly placement

If a Power Distribution Assembly is installed on an FTA Mounting Channel with a Galvanically Isolated FTA, it must be installed with its eight 2-pin power connectors at the top of the assembly. When the Power Distribution Assembly is installed on a vertical FTA Mounting Channel, it is installed with its 6-pin power connectors at the top of the assembly.

Field wiring restrictions

Field wires terminating on Galvanically Isolated FTAs must be routed at least 2 inches away from any other wires or electrical components, or a nonconductive material or grounded metal barrier must be provided for separation.

Field wiring routing

If the field wires leaving the Galvanically Isolated FTAs are dressed downward toward the bottom of the cabinet, the Power Distribution Assembly(s) must be installed above the FTAs. As a result, the field wires will not pass close to a Power Distribution Assembly. If the field wires are routed upward toward the top of the cabinet, the Power Distribution Assembly(s) must be installed below the FTAs.

FTA Mounting Channel cabling assignment

All power cables must be routed in the upper channel of the FTA Mounting Channel. The field wires to the Galvanically Isolated FTAs must always be routed in the lower channel of the FTA Mounting Channel. No other wires, other than field wires to Galvanically Isolated FTAs, can be routed in the lower channel of the FTA Mounting Channel.

15.4.1 Power Distribution Assembly

Overview

The model MU-GPRD02 Galvanic Isolation Power Distribution Assembly provides individually fused 24 Vdc power for the Galvanically Isolated FTAs.

The dc power is supplied to the Galvanic Isolation Power Distribution Assembly by the same type of 6-pin connector cable, model MU-KDPRxx (the suffix “xx” represents the length of the cable in meters), used to supply power to the card files from the Process Manager’s or Advanced Process Manager’s Power System when the assembly is located in the same cabinet or cabinet complex.

If the Galvanic Isolation Power Distribution Assembly is located external to the cabinet or cabinet complex and CE Compliance is a requirement, model MU-KSPRxx cables must be used. The 2-conductor cable provides only 24 Vdc power.

A single source or dual source (redundant) of power can be supplied because the Power Distribution Assembly has two input power connectors.

Eight 2-pin power connectors

The Power Distribution Assembly has eight 2-pin connectors to which 2-wire power cables can be connected to supply the 24 Vdc power to the power connectors on the Galvanically Isolated FTAs.

Model MU-KGPRxx cables

Two power cable lengths can be ordered by model number. Model MU-KGPR05 is a 5-meter cable and model MU-KGPR10 is a 10-meter cable. Other lengths are available, but the cable must be ordered by part number. Standard lengths are 0.5, 0.75, 1, 1.25, 2, 3, 4, 5 (MU-KGPR05), and 10 (MU-KGPR10) meters (20, 30, 40, 50, 80, 120, 160, 195, and 395 inches). Order by Honeywell part number 51109620-xxx, where “xxx” represents the length of the cable in inches.

Same size as A-size FTA

The Power Distribution Assembly has the same mounting dimensions as an A-size FTA.

15.4.2 Cabling to Power Distribution Assemblies

Overview

Model MU-KDPR_{xx} (the suffix “xx” represents the length of the cable in meters) power cables connect the 6-pin power connectors on the Power System with 6-pin connectors on the Power Distribution Assembly. Cable redundancy is provided by two power cables connected to each Power Distribution Assembly.

The cables can be daisy-chained to up to four Power Distribution Assemblies, provided the current through the series of MU-KDPR_{xx} cables to the most distant Power Distribution Assembly from the Power System does not exceed 12 amperes of 24 Vdc power. The 12 ampere limitation assumes that one of the redundant cables has failed and broken the power loop.

Cable length restrictions

The allowable total length of the model MU-KDPR_{xx} cables is also determined by the current through them. The length in meters cannot exceed 33 divided by the amount of current in amperes in the series of cables. This allows a 1/2 volt drop for the series of cables. Once again, assume that one of the redundant cables has failed when calculating the length.

15.4.3 Cabling to FTAs

Overview

The Power Distribution Assembly has eight 2-pin connectors that supply 24 Vdc power to the FTAs through model MU-KGPR_{xx} (the suffix “xx” represents the length of the cable in inches) cables. The cable is not shielded and must not exit the cabinet, unless in conduit, for a CE Compliance application. Each FTA must have two cables connected to it to provide a redundant source of power. The cabling must not be daisy-chained to the FTAs.

Cable length restrictions

The allowable total length of the model MU-KGPR_{xx} cables is also determined by the current through them. The length in meters cannot exceed 13 divided by the amount of current in amperes in the series of cables. In any case, the total length cannot exceed 10 meters. This allows a 1/2 volt drop for the series of cables. When calculating the length, assume that one of the redundant cables has failed, and the other cable(s) is carrying all the current.

Typical cabinet configuration

A typical cabinet side might have 12 FTAs and 3 Power Distribution Assemblies, and a 12-inch unused length of FTA Mounting Channel.

15.4.4 Power Considerations

Recommendations

Use the following recommendations for planning your Galvanic Isolation FTA power system configuration and power cabling when the subsystem consists of either nonredundant or redundant IOPs.

Avoid using a non-PM/APM power source

Avoid providing 24 Vdc power to the Galvanically Isolated FTAs from a separate power system that is “disassociated” from the Process Manager or Advanced Process Manager Power System. A “disassociated” power system is one that is part of a larger system. Try to use power systems that are local to the loads that they serve.

Use surplus power for the FTAs

If redundant PMMs or APMMs are both powered from one Power System, use whatever surplus power there is in the system to power the Galvanically Isolated FTAs. Add another Power System, if necessary.

If redundant PMMs or APMMs are each powered by their own Power System, use surplus power from both systems to power the FTAs. If more power is needed for the FTAs, use power from an additional Power System.

15.5 High Level Analog Input (HLAI) FTAs

15.5.1 Model MU-GAIH12/MU-GAIH82 FTA

15.5.1.1 Description

Introduction

The model MU-GAIH12 and MU-GAIH82 High Level Analog Input (HLAI) FTAs accommodate up to 16 high level dc signals. The FTA provides floating dc power to energize a 2-wire or 3-wire, 4-20 mA transmitter in a hazardous area and repeats the current accurately in another circuit to drive a range spool in the safe area that generates a 1 to 5 Vdc signal to the associated HLA IOP.

Field transmitter compatibility

The FTA is suitable for conventional transmitters only.

References

The *Process Manager I/O Specification and Technical Data* and *Process Manager I/O Installation* manuals provide a more detailed description of the FTA's specifications and additional information.

15.5.1.2 Connectors

Two IOP connectors

Two 50-pin connectors provide the interfaces to redundant IOPs. A nonredundant configuration is also acceptable.

One auxiliary connector

One 50-pin auxiliary connector provides signals for remote monitoring and alarming equipment.

15.5.1.3 Field Wiring Input Signals

Signal limits

The acceptable input signal is from a 4-20 mA 2-wire or 3-wire transmitter. It is not expected that any self-powered transmitters will be the source.

With an open circuit, the voltage to the transmitter wires is a maximum 28 volts. At 20 mA of transmitter current, the voltage is a minimum 15 volts.

Field device connections

Each Galvanic Isolation Module accepts one field device connection.

15.5.1.4 Auxiliary Connector Output

Description

The 1 to 5 Vdc PV signals are available at the auxiliary connector. By the use of a model MU-KFTAxx cable (the suffix “xx” represents the cable length of the cable in meters), the signals can be connected to a model MU-GMAR52 Marshalling Panel where they are available at screw terminals. If these signals are connected to monitoring or recording devices, the devices should have at least 1 megohm of input resistance to avoid loading the signals. See subsection 15.10 for a description of the Marshalling Panel.

15.5.1.5 Indicators

Primary IOP active indicator

A green indicator on the FTA illuminates when the primary IOP (A) is active.

GI module power indicator

A green indicator on each Galvanic Isolation Module illuminates when power is applied to the module.

15.5.1.6 Current Consumption

Maximum power requirement

The FTA consumes 1.28 amperes at 24 Vdc with a 20 mA signal present at all inputs. This represents 30.7 watts of power.

Power dissipation

The power dissipation is 25.0 watts with a 20 mA signal at all inputs.

15.5.1.7 Isolation and Safety

Specifications

The isolation between the safe-side and hazardous-side of the FTA is 250 Vac. The Galvanic Isolation Module separates the two sides.

The safety description for the Galvanic Isolation Module input is

- 28 volts maximum
 - 300 ohms
 - 93 milliamps maximum
-

15.5.2 Model MU-GAIH13/MU-GAIH83 FTA

15.5.2.1 Description

Introduction	The model MU-GAIH13 and MU-GAIH83 High Level Analog Input/Smart Transmitter Interface (HLAI/STI) FTAs accommodate up to 16 high level dc signals. The FTA provides floating dc power to energize a 2-wire or 3-wire, 4-20 mA transmitter in a hazardous area and repeats the current accurately in another circuit to drive a range spool in the safe area that generates a 1 to 5 Vdc signal to the associated HLA IOP.
Field transmitter compatibility	The FTA is suitable for conventional and “smart” transmitters whose digital communication signals are superimposed on a standard 4-20 mA signal. The smart transmitter can be calibrated, interrogated, or tested from the TDC 3000 ^X , or from a hand-held communicator connected to the hazardous-side connector terminals on the Galvanic Isolation Module or connected across points on the FTA board.
References	The <i>Process Manager I/O Specification and Technical Data</i> and <i>Process Manager I/O Installation</i> manuals provide a more detailed description of the FTA’s specifications and additional information.

15.5.2.2 Connectors

Two IOP connectors	Two 50-pin connectors provide the interfaces to redundant IOPs. A nonredundant configuration is also acceptable.
One auxiliary connector	One 50-pin auxiliary connector provides signals for remote monitoring and alarming equipment.

15.5.2.3 Field Wiring Input Signals

Signal limits

Each Galvanic Isolation Module on the HLAI/STI FTA provides a floating dc source for energizing conventional 2-wire or 3-wire 4-20 mA transmitters or smart transmitters, such as the Honeywell model ST3000 SMARTLINE transmitter, whose digital communications signal is superimposed on a 4-20 mA signal.

With an open circuit, the voltage to the transmitter wires is a maximum 28 volts. At 20 mA of transmitter current, the voltage is a minimum 15 volts.

Field device connections

Each Galvanic Isolation Module accepts one field device connection.

15.5.2.4 Auxiliary Connector Output

Description

The 1 to 5 Vdc PV signals are available at the auxiliary connector. By the use of a model MU-KFTAxx cable (the suffix “xx” represents the cable length of the cable in meters), the signals can be connected to a model MU-GMAR52 Marshalling Panel where they are available at screw terminals. If these signals are connected to monitoring or recording devices, the devices should have at least 1 megohm of input resistance to avoid loading the signals. See subsection 15.10 for a description of the Marshalling Panel.

15.5.2.5 Indicators

Primary IOP active indicator

A green indicator on the FTA illuminates when the primary IOP (A) is active.

GI module power indicator

A green indicator on each Galvanic Isolation Module illuminates when power is applied to the module.

15.5.2.6 Hand-Held Communicator

Smart Transmitter communication

Terminals 3 and 4 on the Galvanic Isolation Module are internally connected to the two field terminals and can be used to communicate with a smart transmitter.

15.5.2.7 Current Consumption

Maximum power requirement

The FTA consumes 1.28 amperes at 24 Vdc with a 20 mA signal present at all inputs. This represents 30.7 watts of power.

Power dissipation

The power dissipation is 25.0 watts with a 20 mA signal at all inputs.

15.5.2.8 Isolation and Safety

Specifications

The isolation between the safe-side and hazardous-side of the FTA is 250 Vac. The Galvanic Isolation Module separates the two sides.

The safety description for the Galvanic Isolation Module input is

- 28 volts maximum
 - 300 ohms
 - 93 milliamps maximum
-

15.5.3 Model MU-GAIH14/MU-GAIH84 FTA

15.5.3.1 Description

Introduction	<p>The model MU-GAIH13 and MU-GAIH83 High Level Analog Input/Smart Transmitter Interface (HLAI/STI) FTAs accommodate up to 16 high level dc signals. The model MU-GAIH14/MU-GAIH84 FTA is similar to the model MU-GAIH13/MU-GAIH83 FTA, except for its safety specifications and the available field terminal voltage is higher. This permits longer field wiring.</p> <p>The FTA provides floating dc power to energize 2-wire or 3-wire, 4-20 mA transmitters in a hazardous area and repeats the current accurately in another circuit to drive a range spool in the safe area that generates a 1 to 5 Vdc signal to the associated HLAI IOP.</p>
Field transmitter compatibility	<p>The FTA is suitable for conventional and “smart” transmitters whose digital communication signals are superimposed on a standard 4-20 mA signal. The smart transmitter can be calibrated, interrogated, or tested from the TDC 3000^X, or from a hand-held communicator connected to the hazardous-side connector terminals on the Galvanic Isolation Module or connected across points on the FTA board. The communicator can also be connected to the field-side terminals on the Galvanic Isolation Module.</p>
References	<p>The <i>Process Manager I/O Specification and Technical Data</i> and <i>Process Manager I/O Installation</i> manuals provide a more detailed description of the FTA’s specifications and additional information.</p>

15.5.3.2 Connectors

Two IOP connectors	<p>Two 50-pin connectors provide the interfaces to redundant IOPs. A nonredundant configuration is also acceptable.</p>
One auxiliary connector	<p>One 50-pin auxiliary connector provides signals for remote monitoring and alarming equipment.</p>

15.5.3.3 Field Wiring Input Signals

Signal limits

Each Galvanic Isolation Module on the HLAI/STI FTA provides a floating dc source for energizing conventional 2-wire or 3-wire 4-20 mA transmitters or smart transmitters, such as the Honeywell model ST3000 Smartline transmitter, whose digital communications signal is superimposed on a 4-20 mA signal.

With an open circuit, the voltage to the transmitter wires is a maximum 28 volts. At 20 mA of transmitter current, the voltage is a minimum 15 volts.

Field device connections

Each Galvanic Isolation Module accepts one field device connection.

15.5.3.4 Auxiliary Connector Output

Description

The 1 to 5 Vdc PV signals are available at the auxiliary connector. By the use of a model MU-KFTAx_x cable (the suffix “xx” represents the cable length of the cable in meters), the signals can be connected to a model MU-GMAR52 Marshalling Panel where they are available at screw terminals. If these signals are connected to monitoring or recording devices, the devices should have at least 1 megohm of input resistance to avoid loading the signals. See subsection 15.10 for a description of the Marshalling Panel.

15.5.3.5 Indicators

Primary IOP active indicator

A green indicator on the FTA illuminates when the primary IOP (A) is active.

GI module power indicator

A green indicator on each Galvanic Isolation Module illuminates when power is applied to the module.

15.5.3.6 Hand-Held Communicator

Smart Transmitter communication

Terminals 3 and 4 on the Galvanic Isolation Module are internally connected to the two field terminals and can be used to communicate with a smart transmitter.

15.5.3.7 Current Consumption

Maximum power requirement

The FTA consumes 1.2 amperes at 24 Vdc with a 20 mA signal present at all inputs. This represents 28.2 watts of power.

Power dissipation

The power dissipation is 20.8 watts with a 20 mA signal at all inputs.

15.5.3.8 Isolation and Safety

Specifications

The isolation between the safe-side and hazardous-side of the FTA is 250 Vac. The Galvanic Isolation Module separates the two sides.

The safety description for the Galvanic Isolation Module input is

- 28 volts maximum
 - 234 ohms
 - 119 milliamps maximum
-

15.5.4 Model MU-GAIH22/MU-GAIH92 FTA

15.5.4.1 Description

Introduction

The model MU-GAIH22 and MU-GAIH92 High Level Analog Input (HLAI) FTAs accommodate up to 16 high level dc signals. The FTA provides floating dc power to energize a 2-wire or 3-wire, 4-20 mA transmitter in a hazardous area and repeats the current accurately in another circuit to drive a range spool in the safe area that generates a 1 to 5 Vdc signal to the associated HLAI IOP.

The model MU-GAIH22 and MU-GAIH92 FTAs is similar to the model MU-GAIH14 and MU-GAIH84 FTAs, except the 4-20 mA output signal from the Galvanic Isolation Module can be routed to an auxiliary receiver through an auxiliary connector before it is sent to the range spool on the FTA to generate the 1-5 Vdc input to the IOP.

Field transmitter compatibility

The FTA is suitable for conventional transmitters only.

References

The *Process Manager I/O Specification and Technical Data* and *Process Manager I/O Installation* manuals provide a more detailed description of the FTA's specifications and additional information.

15.5.4.2 Connectors

Two IOP connectors

Two 50-pin connectors provide the interfaces to redundant IOPs. A nonredundant configuration is also acceptable.

One auxiliary connector

One 50-pin auxiliary connector provides 4-20 mA signals to auxiliary devices.

15.5.4.3 Field Wiring Input Signals

Signal limits

The acceptable input signal is from a 4-20 mA 2-wire or 3-wire transmitter. It is not expected that any self-powered transmitters will be the source.

With an open circuit, the voltage to the transmitter wires is a maximum 28 volts. At 20 mA of transmitter current, the voltage is a minimum 15 volts.

Field device connections

Each Galvanic Isolation Module accepts one field device connection.

15.5.4.4 Auxiliary Connector Output

Description

The 1 to 5 Vdc PV signals are available at the auxiliary connector. By the use of a model MU-KFTAxx cable (the suffix “xx” represents the cable length of the cable in meters), the signals can be connected to a model MU-GMAR52 Marshalling Panel where they are available at screw terminals. Because it is the same 4-20 mA signal that the range spool is exposed to, the recording or monitoring system connected to the screw terminals of the Marshalling Panel must provide a low impedance of 250 ohms, or less. See subsection 15.10 for a description of the Marshalling Panel.

15.5.4.5 Indicators

Primary IOP active indicator

A green indicator on the FTA illuminates when the primary IOP (A) is active.

GI module power indicator

A green indicator on each Galvanic Isolation Module illuminates when power is applied to the module.

15.5.4.6 Current Consumption

Maximum power requirement

The FTA consumes 1.2 amperes at 24 Vdc with a 20 mA signal present at all inputs. This represents 28.8 watts of power.

Power dissipation

The power dissipation is 20.8 watts with a 20 mA signal at all inputs.

15.5.4.7 Isolation and Safety

Specifications

The isolation between the safe-side and hazardous-side of the FTA is 250 Vac. The Galvanic Isolation Module separates the two sides.

The safety description for the Galvanic Isolation Module input is

- 28 volts maximum
 - 300 ohms
 - 93 milliamps maximum
-

15.6 24 Vdc Digital Input FTAs

15.6.1 Model MU-GDID12/MU-GDID82 FTA

15.6.1.1 Description

Introduction

The model MU-GDID12 and MU-GDID82 24 Vdc Digital Input (DI) FTAs accommodate up to 32 switch or proximity detector inputs from a hazardous area, isolate the signal, and present them to the FTA's associated 24 Vdc Digital Input FTA in the safe area. The phase of the input signals is selectable, which allows the alarm condition to be chosen for either state of the sensor. This is accomplished with independent switches on the top of the Galvanic Isolation Modules.

Fault-line detection

Individual line-fault detection is provided, that signals a contact change in the event the field wires are shorted or open. Switches are provided on the Galvanic Isolation Module to optionally defeat the line-fault detection on an individual input basis.

References

The *Process Manager I/O Specification and Technical Data* and *Process Manager I/O Installation* manuals provide a more detailed description of the FTA's specifications and additional information.

15.6.1.2 Connectors

Two IOP connectors

Two 50-pin connectors provide the interfaces to redundant IOPs. Presently, redundant Digital Input IOPs are not supported.

One auxiliary connector

One 50-pin auxiliary connector provides signals for remote monitoring and alarming systems.

15.6.1.3 Field Wiring Input Signals

Specifications

The input signal specifications and assumptions are as follows.

- Input from a contact or proximity switch.
 - A sensed current of less than 2 kohms resistance is interpreted as a closure.
 - The hysteresis is nominally 650 ohms.
 - The voltage applied to the sensor is 7.7 to 9.0 Vdc for 1 kohms resistance.
-

15.6.1.4 Line-Fault Detection

Definition

The Galvanic Isolation Module signals a change of state to the IOP if the field wires are open or shorted. An open wire is defined as an input current of less than 100 μ A, and a shorted wire is defined as an input current of greater than 6.5 mA.

ATTENTION

ATTENTION—To prevent false triggering of the line-fault detection feature, proximity sensors must be used. If switch inputs are used, they must be fitted with series and shunt resistors so that an open switch provides 22 kohms resistance and a closed switch provides 620 ohms resistance. If this feature is not wanted, it can be disabled by placing two switches on the top of the Galvanic Isolation Module, one for each input, in the “off” position.

15.6.1.5 Auxiliary Connector Output

Auxiliary contact signals

Duplicate floating dry contacts that track the action of the signals presented to the IOP are provided by the auxiliary connector. There are two contacts in each module, isolated from the system, but not isolated from each other (three wires per isolator).

Marshalling Panel connection

By the use of a model MU-KFTAxx cable (the suffix “xx” represents the length of the cable in meters), the signals can be connected to the model MU-GMAR52 Marshalling Panel where the signals are available at screw terminals. See subsection 15.10 for a description of the Marshalling Panel.

15.6.1.6 Indicators

Primary IOP active indicator	A green indicator on the FTA illuminates when the primary IOP (A) is active.
GI module signal indicators	Two amber indicators on each Galvanic Isolation Module, one for each input, illuminates when a “closed” signal is sent to the IOP.
GI module power indicator	A green indicator on each Galvanic Isolation Module illuminates when power is applied to the module.

15.6.1.7 Current Consumption

Specifications	<p>The FTA consumes 0.72 amperes at 24 Vdc with all inputs in use. This represents 17.3 watts of power.</p> <p>The power dissipation is 16 watts with all inputs active.</p>
-----------------------	--

15.6.1.8 Isolation and Safety

Specifications	<p>Isolation is 250 Vac between each input, each auxiliary set of contacts, and the Process Manager or Advanced Process Manager.</p> <p>The safety description for each Galvanic Isolation Module input is</p> <ul style="list-style-type: none">• 10.5 volts maximum• 800 ohms• 14 milliamps maximum
-----------------------	---

15.6.2 Model MU-GDID13/MU-GDID83 FTA

15.6.2.1 Description

Introduction

The model MU-GDID12 and MU-GDID82 24 Vdc Digital Input (DI) FTAs accommodate up to 32 switch or proximity detector inputs from a hazardous area, isolate the signal, and present them to the FTA's associated 24 Vdc Digital Input FTA in the safe area. The FTA is similar to the model MU-GDID12/MU-GDID82 FTA, except the phase of the Galvanic Isolation Module's input to output signals are not selectable on the module and the module's signal outputs are solid-state, instead of contacts. Also, the FTA has no auxiliary output connector.

References

The *Process Manager I/O Specification and Technical Data* and *Process Manager I/O Installation* manuals provide a more detailed description of the FTA's specifications and additional information.

15.6.2.2 Connectors

Two IOP connectors

Two 50-pin connectors provide the interfaces to redundant IOPs. Presently, redundant Digital Input IOPs are not supported.

15.6.2.3 Field Wiring Input Signals

Specifications

The input signal specifications and assumptions are as follows.

- Input from a contact or proximity switch.
 - A sensed current of less than 2 kohms resistance is interpreted as a closure.
 - The hysteresis is nominally 650 ohms.
 - The voltage applied to the sensor is 7.7 to 9.0 Vdc for 1 kohms resistance.
-

15.6.2.4 Indicators

Primary IOP active indicator	A green indicator on the FTA illuminates when the primary IOP (A) is active.
GI module signal indicators	Two amber indicators on each Galvanic Isolation Module, one for each input, illuminates when a “closed” signal is sent to the IOP.
GI module power indicator	A green indicator on each Galvanic Isolation Module illuminates when power is applied to the module.

15.6.2.5 Current Consumption

Specifications	<p>The FTA consumes 0.56 amperes at 24 Vdc with all inputs in use. This represents 13.4 watts of power.</p> <p>The power dissipation is 14.4 watts with all inputs active.</p>
-----------------------	--

15.6.2.6 Isolation and Safety

Specifications	<p>Isolation is 250 Vac between each input, each auxiliary set of contacts, and the Process Manager or Advanced Process Manager.</p> <p>The safety description for each Galvanic Isolation Module input is</p> <ul style="list-style-type: none">• 10.5 volts maximum• 800 ohms• 14 milliamps maximum
-----------------------	---

15.7 Analog Output FTAs

15.7.1 Model MU-GAOX02/72 and MU-GAOX12/82 FTAs

15.7.1.1 Description

Overview

The nonredundant model, MU-GAOX02 and MU-GAOX72, and the redundant model, MU-GAOX12 and MU-GAOX82, Analog Output (AO) FTAs isolate up to eight 4-20 mA signals that can drive current-to-pressure (I/P) transducers, position actuators, or any load of 750 ohms or less, from an associated Analog Output IOP. The two models are identical in performance, with the redundant model capable of being controlled from redundant IOPs.

References

The *Process Manager I/O Specification and Technical Data* and *Process Manager I/O Installation* manuals provide a more detailed description of the FTA's specifications and additional information.

15.7.1.2 Connectors

Two IOP connectors

Two 50-pin connectors on the redundant model of the FTA provide the interfaces to one or two IOPs.

Analog Output Standby Manual connector

One 50-pin connector accepts signals from an Analog Output Standby Manual Device, permitting removal and replacement of an IOP during normal operation of the FTA.

15.7.1.3 Field Wiring Output Signals

Specifications

The FTA provides, nominally, 4-20 mA for control of field devices that are Galvanically Isolated from all other circuits. The load resistance can be no greater than 750 ohms. The signal output's dynamic impedance is greater than 1 megohm.

15.7.1.4 Line-Fault Detection

Description

In the event of an open or short circuit in the field wiring, the resistance sensed at the input to the Galvanic Isolation Module will be a high value. This permits the readback feature of the associated 4-20 mA Analog Output IOP to detect the open or shorted field circuit and report a soft failure to the user.

15.7.1.5 Calibration

Calibration terminals

Four screw terminals are provided on the FTA, two pairs for calibrating the primary and secondary IOPs. A touch pad is provided that initiates the calibration procedure in primary or secondary IOP.

15.7.1.6 Indicators

Primary IOP active indicator

A green indicator on the FTA illuminates when the primary IOP (A) has control of the FTA.

GI module indicator

A green indicator on each Galvanic Isolation Module illuminates when power is applied to the module.

15.7.1.7 Current Consumption

Specifications

Both models of the FTA consume 0.42 amperes at 24 Vdc with a 20 mA signal on all outputs. This represents 10.5 watts of power.

The power dissipation for the FTA is 9.6 watts with all outputs providing 20 mA of current.

15.7.1.8 Isolation and Safety

Specifications

The isolation between the safe-side and hazardous-side of the FTA is 250 Vac. The Galvanic Isolation Module divides the two sides.

The safety description for the output of each Galvanic Isolation Module is

- 28 volts maximum
 - 300 ohms
 - 93 milliamps maximum
-

15.8 24 Vdc Digital Output FTAs

15.8.1 Model MU-GDOD12/MU-GDOD82 FTA

15.8.1.1 Description

Introduction	The model MU-GDOD12 and MU-GDOD82 24 Vdc Digital Output (DO) FTA can drive up to 16 suitably certified, intrinsically safe loads in a hazardous area. The loads can be a solenoid or alarm, as well as a nonenergy storing “simple apparatus,” such as an LED.
References	The <i>Process Manager I/O Specification and Technical Data</i> and <i>Process Manager I/O Installation</i> manuals provide a more detailed description of the FTA’s specifications and additional information.

15.8.1.2 Signal Connectors

IOP connectors	Two 50-pin connectors provide the interfaces to redundant IOPs through model MU-KFTAxx cables (the suffix “xx” represents the length of the cable in meters). Presently, Digital Output IOP redundancy is not supported.
Auxiliary connector	One 50-pin auxiliary connector accepts signals from an emergency shutdown system.

15.8.1.3 Field Wiring Output Signals

Specifications	Each output is a voltage source that provides a maximum output voltage of 25.5 Vdc through 232 ohms. The minimum output voltage varies from 22 volts at zero current to 10 volts at 50 milliamps.
-----------------------	---

15.8.1.4 Auxiliary Connector

Introduction

The auxiliary connector provides an input for control signals from an emergency shutdown system that is user-supplied. The shutdown system must provide potential free-floating sets of contacts. When one of the contacts is closed, a corresponding FTA output is disabled (deenergized), regardless of the output state command from the IOP.

Marshalling Panel connection

By the use of a model MU-KFTA_{xx} cable (the suffix “xx” represents the length of the cable in meters), the signals can be connected to a model MU-GMAR52 Marshalling Panel where the input signals can be connected to screw terminals. See subsection 15.10 for a description of the Marshalling Panel.

15.8.1.5 Indicators

Primary IOP control indicator

A green indicator on the FTA illuminates when the primary IOP (A) has control of the FTA.

GI module power indicator

A green indicator on each Galvanic Isolation Module illuminates when power is applied to the module.

GI module output indicator

An amber indicator on the Galvanic Isolation Module illuminates when the module’s output is active.

15.8.1.6 Standby Manual Device Connector

No dedicated connector

There is no dedicated Standby Manual Device connector on the FTA. An IOP connector interface is used by the Digital Output Standby Manual device to control the output of the FTA.

15.8.1.7 Current Consumption

Power consumption At 25 Vdc and with all outputs active into a 350 ohm load (typical for a solenoid valve), the FTA consumes 1.10 amperes.

Power dissipation The power dissipation is 18.7 watts with all outputs active.

15.8.1.8 Isolation and Safety

Specifications The isolation between the safe-side and hazardous-side of the FTA is 250 Vac. The Galvanic Isolation Module divides the two sides.

The safety description for the output of each Galvanic Isolation Module is

- 25.5 volts maximum
 - 232 ohms
 - 110 milliamps maximum
-

15.8.2 Model MU-GDOL12/MU-GDOL82 FTA

15.8.2.1 Description

Introduction

The model MU-GDOL12 and MU-GDOL82 24 Vdc Digital Output (DO) FTA can drive up to 16 suitably certified, intrinsically safe loads in a hazardous area. The loads can be a solenoid or alarm, as well as a nonenergy storing “simple apparatus,” such as an LED.

No output signal override capability

The FTA is similar to the MU-GDOD12/MU-GDOD82 FTA, except it does not have the capability to accept output override signals from a shutdown device through an auxiliary connector.

Line fault detection capability

Instead, each input channel has line fault detection circuitry that causes a contact closure that is present at an auxiliary connector.

References

The *Process Manager I/O Specification and Technical Data* and *Process Manager I/O Installation* manuals provide a more detailed description of the FTA’s specifications and additional information.

15.8.2.2 Signal Connectors

IOP connectors

Two 50-pin connectors provide the interfaces to redundant IOPs through model MU-KFTAxx cables (the suffix “xx” represents the length of the cable in meters). Presently, Digital Output IOP redundancy is not supported.

Auxiliary connector

A 50-pin connector provides contact closure line fault signals from each of the 16 channels.

15.8.2.3 Field Wiring Output Signals

Specifications

Each output is a voltage source that provides a maximum output voltage of 25.5 Vdc through 232 ohms. The minimum output voltage varies from 22 volts at zero current to 10 volts at 50 milliamps.

15.8.2.4 Auxiliary Connector

Introduction

The auxiliary connector provides Line Fault Detection signals that are represented by a solid-state signal for each of the FTA's 16 channels. Upon detection of a line fault, the Galvanic Isolation Module deenergizes a solid-state switch that has its emitter connected to logic ground. The collector is the output to the auxiliary connector and is not terminated in the module or on the FTA assembly.

The solid-state switch has the following characteristics.

- Maximum off-state voltage = 35 Vdc
 - Maximum on-state voltage = 2 Vdc
 - Maximum off-state leakage current = 10 μ A
 - Maximum on-state current = 50 mA
-

Combiner Panel connection

By the use of a model MU-KFTA_{xx} cable (the suffix "xx" represents the length of the cable in meters), the signals can be connected to the model MU-GLFD02 Combiner Panel where the signals are combined with 16 other LFD signals from another FTA. The combined 32 signals are available as inputs to redundant Digital Input IOPs, model MU-PDIX02. See subsection 15.9 for a description of the Combiner Panel.

Marshalling Panel connection

Using the same cable, the signals can also be connected to the model MU-GMAR02 Marshalling Panel where the signals are available at screw terminals. See subsection 15.10 for a description of the Marshalling Panel.

15.8.2.5 Indicators

Primary IOP control indicator

A green indicator on the FTA illuminates when the primary IOP (A) has control of the FTA.

GI module power indicator

A green indicator on each Galvanic Isolation Module illuminates when power is applied to the module.

GI module output indicator

An amber indicator on the Galvanic Isolation Module illuminates when the module's output is active.

GI module LFD indicator

A red indicator on the Galvanic Isolation Module illuminates when a line fault is detected.

15.8.2.6 Standby Manual Device Connector

No dedicated connector

There is no dedicated Standby Manual Device connector on the FTA. An IOP connector interface is used by the Digital Output Standby Manual device to control the output of the FTA.

15.8.2.7 Current Consumption

Power consumption

At 25 Vdc and with all outputs active into a 350 ohm load (typical for a solenoid valve), the FTA consumes 1.10 amperes.

Power dissipation

The power dissipation is 18.7 watts with all outputs active.

15.8.2.8 Isolation and Safety

Specifications

The isolation between the safe-side and hazardous-side of the FTA is 250 Vac. The Galvanic Isolation Module divides the two sides.

The safety description for the output of each Galvanic Isolation Module is

- 25.5 volts maximum
 - 170 ohms
 - 150 milliamps maximum
-

15.9 Combiner Panel

Introduction

The model MU-GLFD02 Combiner Panel is similar in shape and appearance to an “A” size FTA and contains four 50-pin phone-type connectors and a single green LED indicator.

Purpose

The purpose of the panel is to combine the Line Fault Detection (LFD) outputs (16) of two Digital Output FTAs and present the signals (32) to redundant Digital Input IOPs for integration.

LFD input connectors

Two connectors on the panel connect to the auxiliary connector on two Digital Output FTAs that have line fault-detection capability. Presently, these are the MU-GDOL12/MU-GDOL82 FTAs. The standard IOP to FTA cable is used to provide the connections.

IOP output connectors

The combined 32 LFD outputs are available at two output connectors. One output connector connects to IOP A and the other connector connects to its redundant partner, IOP B. The standard IOP to FTA cable is used to provide the connections.

Primary IOP active indicator

The green LED indicator is illuminated when IOP A is active.

15.10 Marshalling Panel

15.10.1 Description

Introduction	The model MU-GMAR52 Marshalling Panel is similar in shape and appearance to a “B” size FTA. It has 38 screw-terminal connections. There is only one version of the Marshalling Panel. The Marshalling Panel has one 50-pin connector that receives or sends signals to the safe side of the FTA to which it is connected.
Complementary	The Marshalling Panel is complementary and provides the ability to repeat signals into or out of the safe side of the Galvanic Isolation Modules mounted on the FTA.
Signals not intrinsically safe	Although the Marshalling Panel is used with the FTAs, the signals present are not intrinsically safe or inherently Galvanically Isolated; therefore, the signals on the Marshalling Panel cannot be exposed to a Division 1, Zone 0 or Zone 1 environment.
Vertical Bus Bar may be required	Because the Marshalling Panel does not have a built-in shield bus, providing termination for a large number of shield wires requires the use of a Horizontal Bus Bar. The Horizontal Bus Bar is connected to the local Master Reference Ground (Safety Ground for CE Compliance).
Can have general purpose usage	The Marshalling Panel was developed primarily to provide user-accessibility to the signals from the auxiliary connectors on the Galvanically Isolated FTAs, but it can also be used as a general purpose marshalling panel in the Process Manager or Advanced Process Manager subsystem.
Mounting	The model MU-GMAR52 Marshalling Panel can be mounted on either a horizontally or vertically installed FTA Mounting Channel. If it is mounted on a horizontally installed FTA Mounting Channel, no Galvanically Isolated or standard FTAs can also be mounted on the FTA Mounting Channel. Cabling to the Marshalling Panel must be routed in the upper channel and to the left.

15.10.2 Configurations

Six configurations

The screw terminals connection of the Marshalling Panel can assume six configurations, depending upon the model of FTA to which its 50-pin connector is connected through a model MU-KFTAxx cable (the suffix “xx” represents the length of the cable in meters).

The configurations are described in the following subsections.

15.10.2.1 High Level Analog Input FTAs

Introduction

When used with High Level Analog Input (HLAI) FTA or High Level Analog Input/Smart Transmitter Interface (HLAI/STI) FTA, the Marshalling Panel provides either 1 to 5 volt or 4 to 20 mA PV signals.

1 to 5 V signals

The 1 to 5 volt signals are the same signals that the HLAI or STI IOP receives.

4-20 mA signals

The 4 to 20 mA signals must be returned to the FTA to produce the 1 to 5 volt signal across a spool resistor that the IOP requires.

Recording or monitoring devices

The signals are intended to be connected to a recording or monitoring device that the user provides.

1-5 Vdc FTAs

The following FTAs provide 1 to 5 volt signals.

- Model MU-GAIH12/82 HLAI FTA
 - Model MU-GAIH13/83 HLAI/STI FTA
 - Model MU-GAIH14/84 HLAI/STI FTA
-

Subsystem input impedance

The subsystem must have an input impedance of 1 megohm, or greater, to avoid loading down the signals and introducing errors into the IOP.

4-20 mA FTA

The following FTA provides 4 to 20 mA signals.

- Model MU-GAIH22/92 HLAI FTA
-

Subsystem input impedance

The subsystem must have an input impedance of 250 ohms or less.

Continued on next page

15.10.2.1 High Level Analog Input FTAs, Continued

Cable routing	The signal wires must be separated from other wires or cables that might induce noise onto the signals. It is suggested that you use a properly grounded, shielded, twisted-pair cable to carry the signals to the recording or monitoring device.
Reference	A list of the signals available at the screw terminals of the Marshalling Panel when it is connected to a High Level Analog Input FTA or High Level Analog Input/Smart Transmitter Interface FTA through its 50-pin auxiliary connector can be found in the <i>Process Manager I/O Installation</i> manual.

15.10.2.2 Digital Input FTAs

Model MU-GDID12/82 FTA configuration	The model MU-GDID12/82 FTA provides potential free sets of contacts that are isolated from the input to the IOP to which the FTA is connected.
Relay contact interface	Each Digital Input Galvanic Isolation Module mounted on the FTA has two double-pole on/off reed relays. One set of the reed relay contacts is connected to the IOP, the second set of relay contacts is connected to the Marshalling Panel. The contact rating is 10 W, 0.5 A at 35 Vdc.
Application	The typical applications for the sets of contacts are inputs to sequence of events recorders, monitoring systems, and shutdown systems.
Reference	A list of the signals available at the screw terminals of the Marshalling Panel when it is connected to a Digital Input FTA through its 50-pin auxiliary connector can be found in the <i>Process Manager I/O Installation</i> manual.

15.10.2.3 Digital Output FTAs

Model MU-GDOD12/82 FTA configuration	The Digital Output configuration provides control by contacts or transistors to individually deenergize each Galvanic Isolation Module digital output. For example, an “on” output command from the IOP for a channel can be “overwritten” by a control signal from the Marshalling Panel that forces the output signal “off.” The override signal cannot force the output signal “on.”
Application	The inputs can be control signals from an emergency shutdown subsystem that is user-supplied.
Reference	<p>A list of the signals available at the screw terminals of the Marshalling Panel when it is connected to a model MU-GDOD12/82 FTA through its 50-pin auxiliary connector can be found in the <i>Process Manager I/O Installation</i> manual.</p> <p>To disable a particular channel, a designated pair of terminals are shorted together.</p>
Model MU-GDOL12/82 configuration	The Digital Output configuration for the model MU-GDOL12/82 FTA is an interface that represents input channel-line fault detection from the FTA. Line Fault Detection (LFD) circuitry in each Galvanic Isolation Module controls a solid-state switch output at the FTA’s auxiliary connector. Upon detection of a line fault, the Galvanic Isolation Module deenergizes the solid-state switch that has its emitter connected to logic ground.
Solid-state switch inputs	The collector of the solid-state switch is the output to the auxiliary connector and is not terminated in the module or on the FTA assembly.
Reference	A list of the signals that are available at the screw terminals of the Marshalling Panel when it is connected to a model MU-GDOL12/82 FTA through its 50-pin auxiliary connector can be found in the <i>Process Manager I/O Installation</i> manual.

Index

24 Vdc Digital Input 268, 271
24 Vdc Digital Output 245, 276, 279
3.6 Vdc battery output 32
48 Vdc Battery Backup Module 32
6 Vac output 32

A, B

AC Only Power System 35
aerial lashing 196
ambient temperature 197
 limits 248
Analog Output
 FTA 273
 IOP calibration 274
APMM
 card file 5, 181
 redundancy 181
auxiliary connector 245

C

cabinet
 blank plate 142, 165
 bottom entry 140, 163
 complex 142, 165
 complexing kit 142
 configurations 37
 dimensions 140
 dual access 67, 139, 161
 entry 75
 entry holes 163
 fan assembly 163
 floor template 157, 180
 internal structure 143, 166
 labels 82
 Markhon 137
 placement considerations 82
 remote 40
 Rittal 159
 single 38
 single access 67, 138, 160
 top entry 163
 top panel(s) 140, 163
cabinets
 complexed 39
 dual 39
cable
 clamp rail 75
 clamping 75
 load parameters 100
 model MU-KFTAxx 277
 size 100
calibration, Analog Output IOP 274
card file
 description 147, 170

redundant APMM 181
single APMM 181
types 181

CJR 208
Class I, Division 2 approved components 83
CMOS memory NiCad battery backup 32
code interpretation 81
Cold Junction Reference 208
complexing kit 165
compression-type terminal connector 77
compression-type terminal connector 242
connector
 compression-type terminal 27
 screw-type terminal 27
crimp pin-type terminal connector 77
crimp-type terminal connector 241
current limiting 101
 resistor 101

D

Division 2 (Zone 2) 81

E

EIA-232 215, 224
EIA-422/485 215, 224
electrical code approval 83
electrical codes 80

F

Factory Mutual 82
fan assembly 140
fiber cable
 bend radius 199
 breakout 200
 breakout kit 200
 burial 196
 clamping 197
 code restrictions 197
 construction 199
 installation planning 200
 installation precautions 199
 loop 197
 migration 197
 multi-fiber 198
 post installation measurements 206
 preinstalled connectors 201
 professional installers 198
 routing 196
 separation 196
 span distance formula 203, 205
 splices 200
 type 196
fiber cable length 195

Index

fiber optic coupler 190
fiber splices 202
Field Termination Assembly 21
field wire
 routing 253
field wiring 253
fire code requirements 197
fixed screw-type terminal connector 77
fixed-screw terminal connector 28
FTA
 Digital Input 285
 Digital Output 286
 dimensions 68
 features 244
 fuses 247
 galvanically isolated 24
 mounting 26
 rules 68
 selection 68
 Serial Interface 224
 sizes 70, 148, 171
 types 24
FTA Mounting Channel 25, 67, 149, 153, 172, 176,
 239
 number 251
FTA Mounting Channel cabinet configurations 150,
 173
FTAs 24

G

Galvanic Isolation Module 237, 240
 replacement 248
Galvanic Isolation Power Distribution Assembly 254
Galvanically Isolated FTA
 model numbers 240
Galvanically Isolated FTA planning 237
Galvanically Isolated FTAs
 types 243

H

hazardous area classifications 81
High Level Analog Input
 FTA 245, 257, 259, 262, 265
Horizontal Bus Bar 248, 283

I, J, K

I/O Link Extender 190
 Long Distance 193
 Standard 190
IEC 80
ignition threshold 101
independent Power Systems 184
International Electrotechnical Commission 80
Introduction 103

IOP
 redundant 185
 Serial Interface 224
IOP) card file 12
IOPs 13

L

Link A 190
Link B 190
LLAI line frequency clock circuit 32
LLMux
 FTA placement 210
 IOP placement 210
 IOP to Power Adapter cable 218, 230
LLMux FTAs 208
Long Distance
 I/O Link Extender 190
Long Distance I/O Link Extender 19, 193
loss budget 202
 calculation 202
Low Level Analog Input Multiplexer 208

M

Manual/Auto Station 221
Marshalling Panel 246, 277, 283
 configurations 284
 purpose 283
Master Reference Ground 45
Master Reference Ground (Safety Ground for CE
 Compliance) 248, 283
mercury-wetted contacts 211
metallic I/O Link Interface cables 195
Modbus protocol 224
Modbus RTU 233
model 208
 8142-2089 Toledo Weigh Cell 221
 8142-2189 Toledo Weigh Cell 221
MU-GMAR52 258, 260, 263, 266
MU-PLAM02 208
MU-TAMR03 208
MU-TSDT02 215
MU-CBDM01 137
MU-CBDX01 159
MU-CBSM01 137
MU-CBSX01 159
MU-GAIH12 257
MU-GAIH13 259, 262
MU-GAIH22 265
MU-GAIH82 257
MU-GAIH83 259, 262
MU-GAIH92 265
MU-GAOX02 273
MU-GAOX12 273
MU-GAOX72 273
MU-GAOX82 273
MU-GDID12 268, 271

Index

- MU-GDID82 268, 271
- MU-GDOD12 276
- MU-GDOD82 276
- MU-GDOL12 279
- MU-GDOL82 279
- MU-GMAR52 269, 283
- MU-GPRD02 254
- MU-KDPRxx cable 254, 255
- MU-KFTAxx 284
- MU-KGPRxx cable 255
- MU-KLAMxx cable 218, 230
- MU-KSXxxx cable 218, 230
- MU-MASX02 221
- MU-PSDX02 215
- MU-TLPA02 208, 215
- MU-TSDM02 215
- MU-TSDU02 215
- model MU-GDID12/82 24 Vdc Digital Input 245
- model MU-GPRD02 253
- model MU-KFTAxx 239
- multi-ground system 45
- multidrop interface 217, 224

N, O

- National Electrical Code 80
- NEC 80
- NFPA 82
- nonincendive wiring 83
- nonredundant PMM or APMM 191

P, Q

- pluggable connector 77
- PMM or APMM 11
- PMM or APMM and IOP card file combinations 187
- PMM to IOP guidelines 187
- Power Adapter 208, 215
- power connector
 - dual 247
- power considerations 256
- Power Distribution Assembly 247, 253
 - placement 253
- power requirements 247
- Power Supply Module 32
- Power System 32
 - redundancy support 187

R

- redundancy interface cable 184
- redundant
 - APMMs 18, 192
 - IOPs 185
 - PMM card files 185
- remote card file 190

- remote IOP redundancy 186
- removable screw-type terminal connector 77
- removable-screw terminal connector 28

S

- Safety Ground 46
- screw-type terminal connector 77
- SDI
 - FTA placement 218, 230
 - FTA to Power Adapter cable length 218, 230
 - IOP placement 217, 229
- separate cabinet redundancy 183
- Serial Device Interface FTA 215
- Serial Device Interface IOP 215
- Serial Interface 234
 - specifications 234
- SI 234
 - specifications 234
- single cabinet redundancy 182
- single-ground system 46
- spare cable fibers 198
- standard FTA 24
- Standard I/O Link Extender 190
- Standby Manual Device 244
 - connector 244

T

- TC 208
- terminal connectors 248
- thermocouple 208
- top entry 140
- types of fiber splices 202, 204

U

- UCN coaxial cables 76
- UDC 6000 221

V

- Vertical FTA Mounting Channel
 - widths 152

W, X, Y, Z

- wire size 77
- wiring
 - rules 76, 83
 - segregation 76

Index

READER COMMENTS

Honeywell's IAC Automation College welcomes your comments and suggestions to improve future editions of this and other publications.

You can communicate your thoughts to us by fax, mail, or toll-free telephone call. We would like to acknowledge your comments; please include your complete name and address.

BY FAX: Use this form and fax to us at (602) 313-4108

BY TELEPHONE: In the U.S.A. use our toll-free number 1*800-822-7673 (available in the 48 contiguous states except Arizona; in Arizona dial 1-602-313-5558).

BY MAIL: Use this form; detach, fold, tape closed, and mail to us.

Title of Publication: **Process Manager/Advanced Process Manager
Planning** Issue Date: **3/96**

Publication Number: **PM02-501**

Writer: **Bob Koegel**

COMMENTS: _____

RECOMMENDATIONS: _____

NAME _____ DATE _____
TITLE _____
COMPANY _____
ADDRESS _____
CITY _____ STATE _____ ZIP _____

(If returning by mail, please tape closed; Postal regulations prohibit use of staples.)

Communications concerning technical publications should be directed to:

Automation College
Industrial Automation and Control
Honeywell Inc.
2820 West Kelton Lane
Phoenix, Arizona 85023

FOLD

FOLD

From: _____



NO POSTAGE
NECESSARY
IF MAILED
IN THE USA

BUSINESS REPLY MAIL
FIRST CLASS PERMIT NO. 4332 PHOENIX, ARIZONA

POSTAGE WILL BE PAID BY

Honeywell

Industrial Automation and Control
2820 West Kelton Lane
Phoenix, Arizona 85023

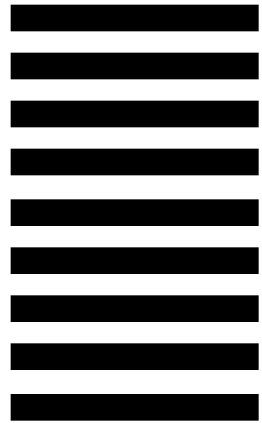

Cut Along Line

Attention: Manager, Quality

FOLD

FOLD

Additional Comments:

Honeywell

Industrial Automation and Control
Honeywell Inc.
16404 North Black Canyon Highway
Phoenix, Arizona 85023-3033

Helping You Control Your World