

**Safety Manager Module  
Installation Guide**  
for use with the Triconex TRICON  
Version 8 systems

SM20-500



**Implementation  
Safety Manager TRICON**

***Safety Manager Module  
Installation Guide***

**for use with the Triconex TRICON  
Version 8 systems**

**SM20-500  
4/96**

# Copyright, Notices, and Trademarks

---

**Printed in U.S.A. – © Copyright 1995 by Honeywell Inc.**

**Revision 03 – March 11, 1996**

While this information is presented in good faith and believed to be accurate, Honeywell disclaims the implied warranties of merchantability and fitness for a particular purpose and makes no express warranties except as may be stated in its written agreement with and for its customer.

In no event is Honeywell liable to anyone for any indirect, special or consequential damages. The information and specifications in this document are subject to change without notice.

This document was prepared using Information Mapping® methodologies and formatting principles.

TDC 3000 and Universal Control Network are U.S. registered trademarks of Honeywell Inc.

Information Mapping is a trademark of Information Mapping Inc.

TRICON and TRISTATION are registered trademarks of Triconex Corporation

Other brand or product names are trademarks of their respective owners.

Honeywell  
Industrial Automation and Control  
Automation College  
2820 West Kelton Lane  
Phoenix, AZ 85023  
(602) 313-5669

## About This Publication

---

This publication includes both general and detailed installation information for the various major components of the Safety Manager (SM) for use with the Triconex TRICON Version 8 systems. Specifically included are

- general installation instructions for the Safety Manager (SM) system,
- detailed installation instructions for installing the Safety Manager Module (SMM), and
- general installation instructions for the TRICON system.

Site planning information is contained in the *TDC 3000<sup>X</sup> System Site Planning Manual*, which is in the *System Site Planning* binder. After installation of the SM, the checkout procedure can be found in the *Safety Manager Module Service Manual*, which is in this binder.

This publication supports software Release 500 series.

---

**All references in this manual to “Safety Manager” or “Safety Manager Module” pertain only for use with the Triconex TRICON Version 8 systems.**



# Table of Contents

---

<b>SECTION 1 – SAFETY MANAGER SYSTEM INSTALLATION .....</b>	<b>1</b>
1.1 Section Overview.....	1
1.2 Equipment Warehousing.....	2
1.3 Move Preparation.....	3
1.4 Unpacking and Placement.....	10
<b>SECTION 2 – SYSTEM COMPONENT INSTALLATION.....</b>	<b>17</b>
2.1 Section Overview.....	17
2.2 Installation Considerations.....	18
2.3 Cabinet Installation.....	19
2.4 Card File Installation.....	20
2.5 Cabling and Wiring Considerations.....	21
2.6 Wiring and Cabling Installation.....	26
2.7 System Power Connections.....	34
2.8 System Ground Connections.....	36
2.9 UCN Connections.....	40
<b>SECTION 3 – SYSTEM COMPONENT CONFIGURATION.....</b>	<b>43</b>
3.1 Section Overview.....	43
3.2 System Configuration Overview.....	44
3.3 Card File Configuration.....	45
<b>SECTION 4 – CONFIGURATION .....</b>	<b>47</b>
4.1 Section Overview.....	47
4.2 TRISTATION UCN Configuration.....	48
4.3 Sequence of Events (SOE) Configuration.....	53
4.4 US Configuration .....	56
<b>APPENDIX A – SMM DATA POINT CONFIGURATION DISPLAYS .....</b>	<b>65</b>
A.1 Overview.....	65
A.2 Analog Input.....	66
A.3 Analog Output.....	68
A.4 Digital Input.....	70
A.5 Digital Output.....	73
A.6 Digital Composite.....	74
A.7 Logic.....	78
A.8 Flag.....	81
A.9 Timer.....	82
A.10 Numeric.....	84

# Figures and Tables

---

Figure 1-1	Typical Electronics Room Layout.....	3
Figure 1-2	SM Cabinet with Two 254 mm (10.0") Trays.....	6
Figure 1-3	SM Cabinet with Two 381 mm (15.0") Trays.....	7
Figure 1-4	SM Cabinet with Three 254 mm (10.0") Trays.....	8
Figure 1-5	SM Cabinet with Four 254 mm (10.0") Trays.....	9
Figure 1-6	Removal of Equipment from Shipping Skid.....	11
Figure 1-7	Removal of Equipment from Shipping Skid—Part 2.....	13
Figure 1-8	Lifting Equipment by Mobile Lifter of Crane.....	14
Figure 1-9	Lifting Equipment by Mobile Lifter of Crane—Part 2.....	15
Figure 1-10	Eye Bolt Crane Method .....	16
Figure 2-1	SMM Frontplate .....	27
Figure 2-2	Non-Redundant SM UCN Cabling .....	28
Figure 2-3	Redundant SM UCN Cabling.....	29
Figure 2-4	I/O Module Set Termination Examples.....	31
Figure 2-5	External Termination Module Example.....	32
Figure 2-6	Safety Manager Cabinet Power and Ground Connections.....	34
Figure 2-7	Connection of the UCN .....	41
Figure 4-1	TRISTATION Module Configurator Screen.....	49
Figure 4-2	TRISTATION File Manager Screen .....	51
Figure 4-3	TRISTATION SOE Block Configuration Screen.....	54
Figure 4-4	US System Status Display.....	57
Figure 4-5	US Engineering Main Menu Display.....	58
Figure 4-6	US NIM Build Type Select Menu.....	59
Figure 4-7	US UCN Node Configuration Display .....	60
Figure 4-8	US Node-Specific Configuration Display .....	61
Figure 4-9	US Process Point Building Display .....	62
Table 1-1	Move Preparation Checklist .....	4
Table 1-2	Move Preparation Checklist .....	5
Table 1-3	Important Unpacking Considerations.....	10
Table 1-4	Fork Lift Considerations.....	11
Table 1-5	Mobile Lifter Considerations .....	12
Table 1-6	Roller Method Considerations.....	15
Table 2-1	Raceway Shielding.....	21
Table 2-2	IEEE 518 Wiring Classification Definitions.....	22
Table 2-3	Tray Spacing.....	23
Table 2-4	Tray/Conduit Spacing.....	23
Table 2-5	Conduit Spacing.....	24
Table 2-6	Cabling and Wiring Guidelines.....	25
Table 2-7	System Grounding Considerations.....	36
Table 4-1	Getting to the TRISTATION UCN Configuration Screen .....	48
Table 4-2	TRISTATION UCN Configuration Parameters .....	50
Table 4-3	Saving and Downloading TRISTATION UCN Data.....	51
Table 4-4	SOE Block Configuration Procedure.....	54
Table 4-5	Saving and Downloading SOE Configuration Data.....	55
Table 4-6	Start-up and Reconfiguration Procedures.....	56
Table 4-7	UCN Configuration.....	56
Table 4-8	UCN Node Configuration.....	59
Table 4-9	SMM Data Point Configuration Procedure.....	63

## Acronyms

---

AI .....	Analog Input
AM .....	Application Module
AO .....	Analog Output
HM .....	History Module
LCN .....	Local Control Network
NIM .....	Network Interface Module
PED .....	Point Entity Data
PI .....	Personality
PLC .....	Programmable Logic Controller
PMM .....	Process Manager Module
RLL .....	Relay Ladder Logic
SM .....	Safety Manager
SMM .....	Safety Manager Module
SOE .....	Sequence of Events
TDC .....	Total Distributed Control
UCN .....	Universal Control Network
US .....	Universal Station

## Parameters

---

DC .....	Digital Composite
DI .....	Digital Input
DO .....	Digital Output
PU .....	Processing Unit

## References

---

Publication Title	Publication Number	Binder Title	Binder Number
<i>Safety Manager Module Control Functions</i>	SM09-500	Implementation Safety Manager TRICON	TDC 3074
<i>Safety Manager Module Parameter Reference Dictionary</i>	SM09-550	Implementation Safety Manager TRICON	TDC 3074
<i>Safety Manager Module Configuration Forms</i>	SM88-500	Implementation Safety Manager TRICON	TDC 3074
<i>TDC 3000<sup>X</sup> System Site Planning Manual</i>	SW02-550	System Site Planning-1	TDC 3020-1
<i>Safety Manager Module Service Manual</i>	SM13-500	Implementation Safety Manager TRICON	TDC 3074

**For TRICON Documentation:**

Document Title	Document Number	Binder Title
<i>TRICON Planning &amp; Installation Guide</i>	9720048-001	TRICON Planning and Installation Guide/ User's Manual for Field Terminations
<i>TRISTATION Multi-System Workstation User's Manual</i>	9720044-001	TRISTATION MSW User's Manual
<i>Safety Manager Module User's Guide</i>	97200XX-001	Manuals for Communication Products
<i>User's Manual for Field Terminations</i>	9720030-001	TRICON Planning and Installation Guide/ User's Manual for Field Terminations
<i>Sequence of Events User's Manual</i>	9720042-001	Manuals for Communication Products

# Section 1 – Safety Manager System Installation

## 1.1 Section Overview

### About this section

This section provides general installation information for the Safety Manager (SM) system. Topics included in this section are:

Subsection	Topic	See Page
1.1	Section Overview .....	1
1.2	Equipment Warehousing .....	2
1.3	Move Preparation .....	3
1.4	Unpacking and Placement.....	10

### Tools and test equipment

The following equipment is necessary for installation of the Safety Manager:

- Mobile lifter/lift truck—refer to Subsection 1.4—*Unpacking and Placement*.
- Carrier band MAP tester—refer to Subsection 2.2—*Installation Considerations*.
- Hand tools and multimeter, as in a typical electrician's tool kit.
- Torque wrench to work in 0 to 70 cm/kg (0 to 60 inch-pound with one inch-pound resolution) range for assembly of UCN cable to their connectors.
- Set of SAE (inch) "crow's foot" wrenches for the above torque wrench.
- ESD kit, Honeywell part number 30185-H.

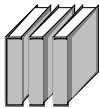

REFERENCE—For detailed information regarding

- site planning and installation, refer to SM02-550 *TDC 3000<sup>X</sup> System Site Planning Manual* in Binder TDC 3020-1 *System Site Planning-1*.
- post-installation checkout procedures, refer to SM13-500 *Safety Manager Module Service* in this binder.

## 1.2 Equipment Warehousing

---

### Factory packing

For shipment, the Safety Manager is packed with desiccant packages, wrapped in a moisture barrier, placed on skids, and optionally enclosed for shipment as required by the user.

---

### Transit/warehousing specifications

The Safety Manager can be shipped by a variety of means, but any trucking should be done by enclosed air-ride electronic vans. The equipment is usually trucked on the final leg of the journey to the user warehouse or site. There it is stored indoors until needed for installation. During the whole process, the environment must be monitored and corrected if the following equipment transit/storage ratings are exceeded:

- Temperature Range: -55° to 85°C (-67° to 158°F)
- Humidity Range: 5 to 95% RH noncondensing

**ATTENTION** In order to minimize exposure to humidity, keep the factory wrapping intact during storage and transit. If it is necessary to unseal the equipment for customs or receiving, add more desiccant and reseal the package.

---

# 1.3 Move Preparation

## Background

Several basic points to keep in mind when planning the movement and unpacking of Safety Manager cabinets include

- a single Safety Manager cabinet is nominally 0.8 x 0.8 x 2 meters (32 x 32 x 79 inches),
- lifting eye bolts, which are removable, add about 5 cm (2 inches) to the height, and
- weight varies with options and can go as high as 385 kg (850 pounds) per cabinet.

As illustrated in Figure 1-1, a typical factory assembled complex uses up to four such cabinets bolted together.

Figure 1-1 Typical Electronics Room Layout

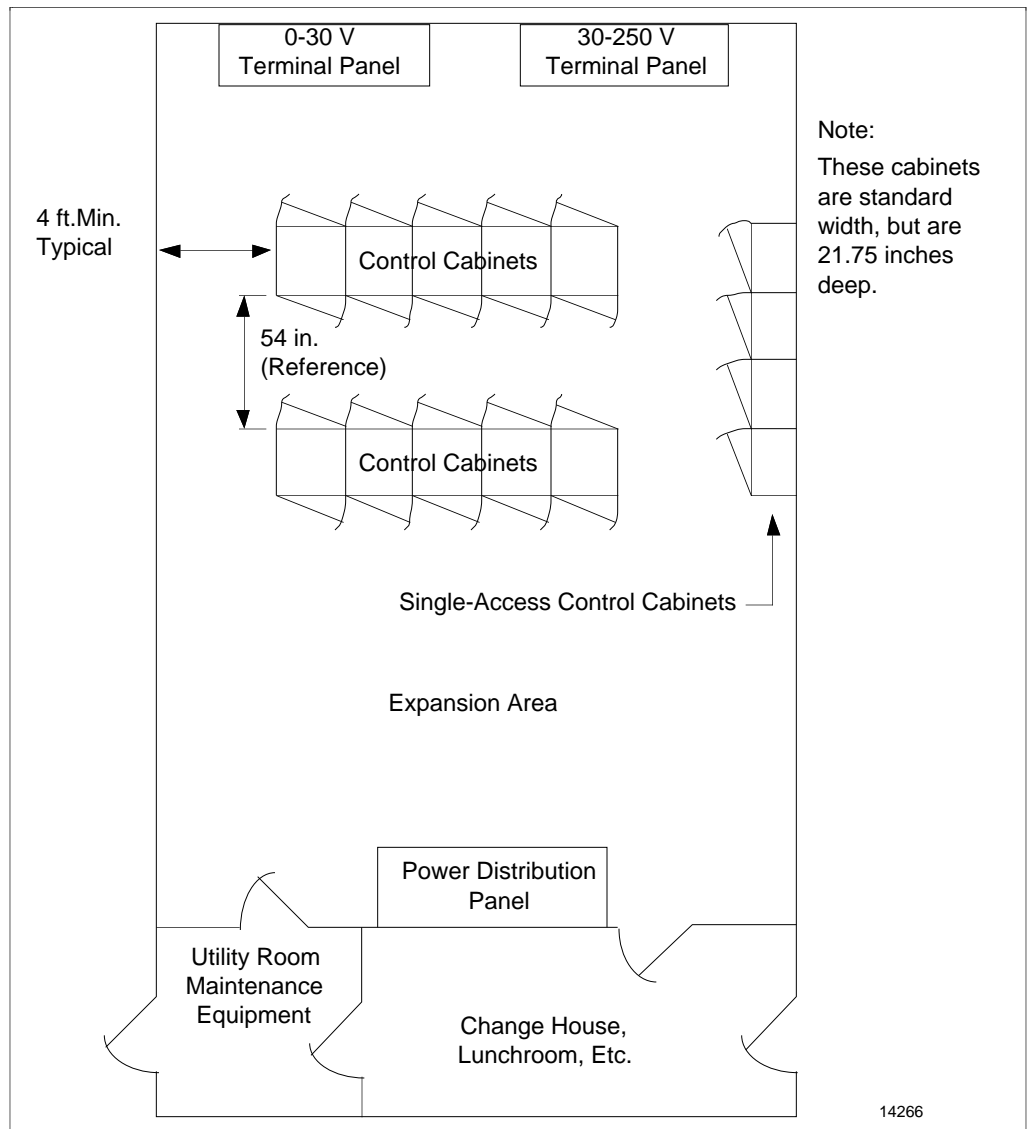

Continued on next page

## 1.3 Move Preparation, Continued

### Checklist

Table 1-1 provides a checklist to be used when planning the movement of Safety Manager cabinets.

Table 1-1 Move Preparation Checklist

Check	Action	Notes
1	Travel Route	Chart the equipment's route of travel regarding <ul style="list-style-type: none"> <li>• loading doors—height and location,</li> <li>• elevators—size, capacity, and availability,</li> <li>• aisles—number, size, and layout,</li> <li>• doorways—number and size,</li> <li>• hallways—size, restrictions, and bends,</li> <li>• stairs and ramps—may require some type of lifting, and</li> <li>• rigging of equipment—if needed.</li> </ul>
2	Space	Is there enough space to hold the equipment?
3	Floor Loading	Will the floor in all areas be strong enough?
4	Power Distribution	Check for proper transformer sizes, distribution panels, and sufficient outlets for support, test, and maintenance equipment.
5	Grounding	Be sure that proper grounds are available.
6	Conduits and Cable Trays	Make sure that conduits and cable trays are large enough and the proper type to accommodate all of the required cables.
7	Environment	Are lighting and other environmental requirements adequate?
8	Security	Provide security clearances for the installation crew if it is not composed of regular employees.
9	Responsibilities	Are all responsibilities clearly defined and understood?
10	Communications	At minimum, three conveniently located telephones are needed for <ul style="list-style-type: none"> <li>• Honeywell Technical Assistance Center (TAC) data terminal,</li> <li>• Honeywell TAC voice, and</li> <li>• Operator Emergency.</li> </ul>

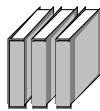

For additional information regarding actions described in the Move Preparation Checklist, refer to SM02-550—*TDC 3000<sup>X</sup> System Site Planning Manual* in the Binder TDC 3020-1 *System Site Planning-1*.

*Continued on next page*

## 1.3 Move Preparation, Continued

### Preparation

Table 1-2 provides a checklist to be used when preparing the electronics room for the Safety Manager cabinets.

Table 1-2 Move Preparation Checklist

Check	Action	Notes
1	Static Electricity	Reduce the ESD borne failures by <ul style="list-style-type: none"> <li>stripping the floors of any wax to prevent static charge buildup,</li> <li>using anti-static spray on floors, furniture, and fabric in the work area, and</li> <li>placing a sign on or near the equipment that states circuit boards are not to be handled without wearing a ground strap.</li> </ul>
2	Tack Rugs	Placed at all entrances, tack rugs catch dust, grit, and abrasives from other areas.
3	Fire Prevention	Consult with the local fire prevention authority to select fire extinguishers suitable for electrical fires.
4	Room Layout	Prepare an electronics room layout diagram for cabinet placement. <ul style="list-style-type: none"> <li>Refer to Figure 1-1.</li> </ul>
5	Cabinet Bolt Down	If this Safety Manager cabinet is to be bolted down, pre-drill holes in the floor. <div style="border: 1px solid black; padding: 2px; display: inline-block; margin-top: 5px;"><b>ATTENTION</b></div> Refer to Figures 1-2 through 1-5 under <i>Cabinet Entry</i> in Subsection 1.3— <i>Move Preparation</i> for placement and dimensions of the bolt down holes.

*Continued on next page*

## 1.3 Move Preparation, Continued

### Cabinet entry

The process signal cables can enter the Safety Manager cabinet through the top or bottom of the cabinet. Figures 1-2 through 1-5 illustrate the placement and dimensions for process wiring.

The Safety Manager cabinet is special, because for bottom entry it has sliding floor plates that can be adjusted to provide entry slots. For top entry, use a hydraulic hole punch to minimize the generation of metal filings. For top or bottom entry, the cables should be clamped firmly to the cabinet. The clamping should be able to handle about a 45 kg (100 pound) pull. This prevents damage inside the cabinet when pulling on cables outside the cabinet.

The Safety Manager cabinet includes a cable clamp rail at the bottom. The rail can be remounted to the top if required.

Figure 1-2 illustrates a Safety Manager cabinet bottom configured for two 254 mm (10.0") cable trays. Also depicted are the cabinet's bolt-down holes and dimensions.

Figure 1-2 SM Cabinet with Two 254 mm (10.0") Trays

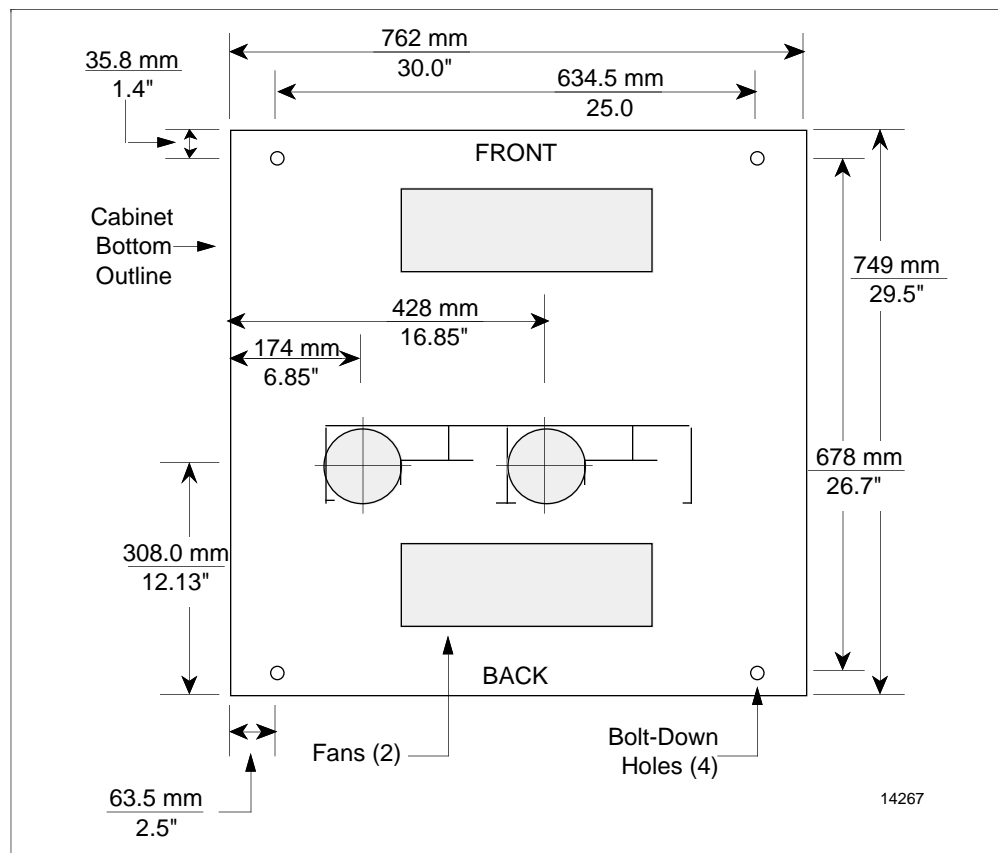

Continued on next page



# 1.3 Move Preparation, Continued

Cabinet entry,  
continued

Figure 1-4 illustrates a Safety Manager cabinet bottom configured for three 254 mm (10.0") cable trays. Also depicted are the cabinet's bolt-down holes and dimensions.

Figure 1-4 SM Cabinet with Three 254 mm (10.0") Trays

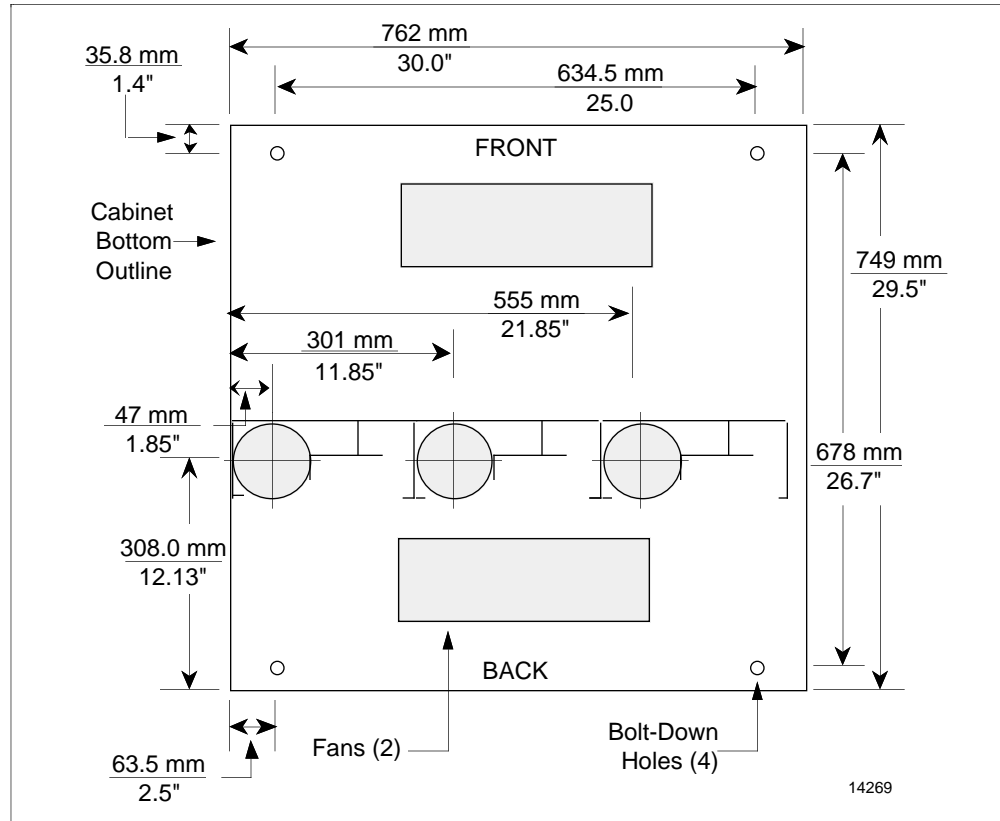

Continued on next page

### 1.3 Move Preparation, Continued

Cabinet entry,  
continued

Figure 1-5 illustrates a Safety Manager cabinet bottom configured for four 254 mm (10.0") cable trays. Also depicted are the cabinet's bolt-down holes and dimensions.

Figure 1-5 SM Cabinet with Four 254 mm (10.0") Trays

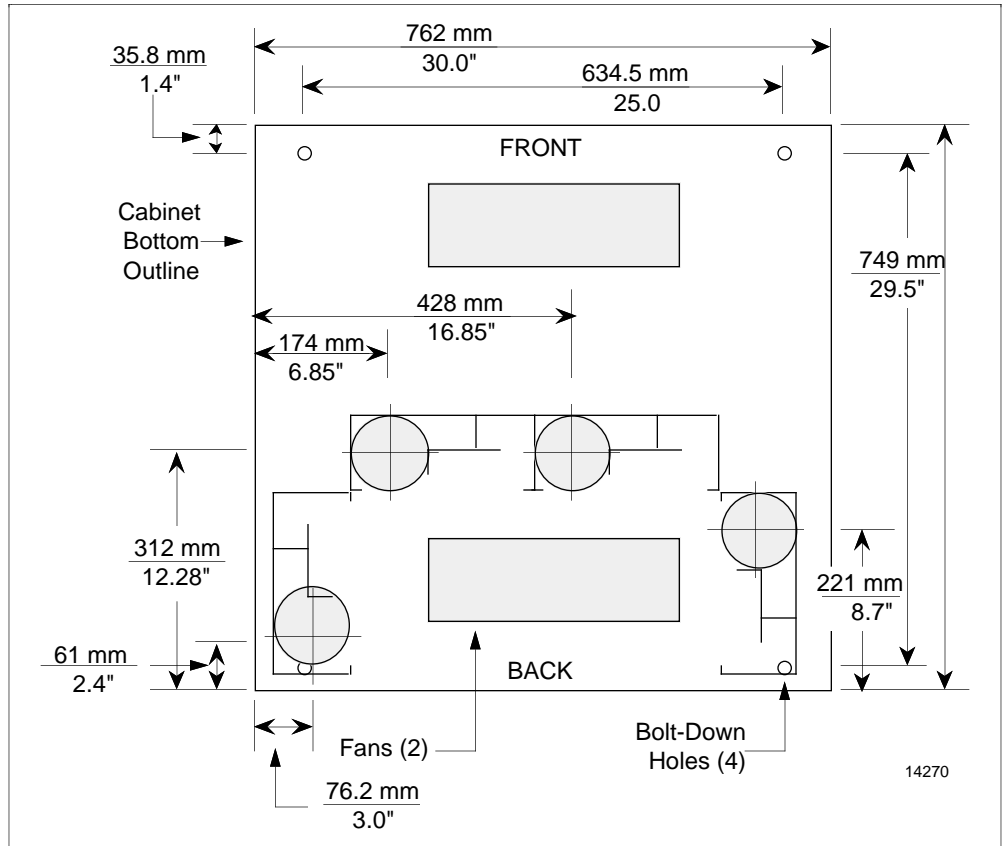

## 1.4 Unpacking and Placement

### Unpacking

Unpack the equipment, check the shipment against the invoice, and notify Honeywell representative of any shortages immediately. Table 1-3 lists important considerations when unpacking the equipment.

Table 1-3 Important Unpacking Considerations

IF ...	THEN ...
the Safety Manager system is comprised of individual card files	the component parts are packaged in labeled boxes.
a Product Registration Label containing the Model Number and Serial Number of the component is affixed to the shipping carton when received	remove and return the label to Honeywell at the noted address to ensure follow-up service and support.

### Moving

The Safety Manager equipment can be moved in any one of four methods:

- fork lift,
- mobile lifter,
- roller, or
- crane.

Special consideration for each of these methods is provided in the following information.

**CAUTION**

When moving the Safety Manager equipment

- use lifters with a capacity of 1100 kg (2500 lbs) or greater, and
- do not tilt the cabinet more than 45° front or back to avoid damaging the doors; they are not recessed.

*Continued on next page*

## 1.4 Unpacking and Placement, Continued

### Fork lift

The Safety Manager, on the original shipping skid, is moved by fork lift to the final location. Table 1-4 lists special considerations regarding the use of a fork lift to move the equipment.

Table 1-4 Fork Lift Considerations

Number	Consideration
1	Move the equipment to the electronics room by fork lift; remove the fork lift.
2	Open the cabinet doors, locate the skid bolts, and remove them.
3	Stack lumber against the pallet to a matching height, as illustrated in Figure 1-6.
4	Manually move the equipment onto the lumber by 10 cm (4 inches).
5	Tip the cabinet weight onto the lumber and pull out the skid.
6	Tip the cabinet off the lumber and onto the floor; remove the lumber.
7	Manually move the cabinet to the exact final position.

Figure 1-6 Removal of Equipment from Shipping Skid

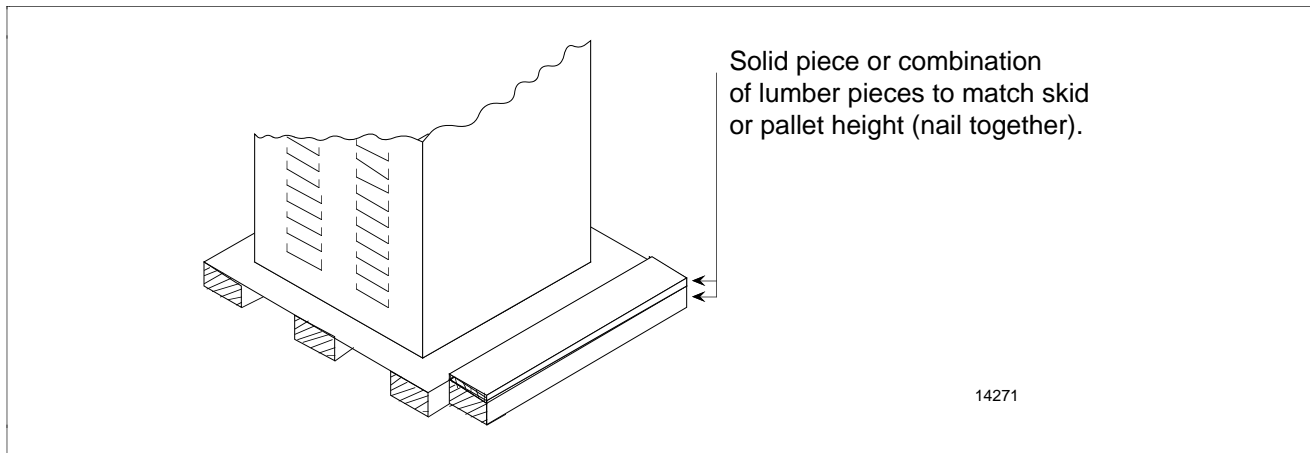

*Continued on next page*

## 1.4 Unpacking and Placement, Continued

### Mobile lifter

As illustrated in Figure 1-7, the Safety Manager is removed from the shipping skid and placed on a transport skid made from angle iron. It is then moved with a mobile lifter. Table 1-5 lists special considerations regarding the use of a mobile lifter to move the equipment.

Table 1-5 Mobile Lifter Considerations

Number	Consideration
1	Remove any steel bands, turnbuckles, and cables securing the equipment to the shipping skid.
2	Open the cabinet doors and locate the bolts holding the cabinets to the shipping skid; remove them and close the doors.
3	Tilt the equipment slightly and slide one of the angle irons used to make up a transport skid underneath the cabinet as in Figure 1-7.
4	Repeat the above step for the other angle.
5	Insert a strip of heavy cardboard between each angle iron and the equipment finish.
6	Tighten the angle irons against the cabinet by tapping slightly.
7	Insert and tighten two 12 mm (1/2-inch) minimum, threaded cross rods as in Figures 1-7 and 1-8.
8	Spread the lifter forks to 0.8 m (32-inch) centers and put them under each cross rod. Place the fork's dowels between the cross rods and the cabinet, just touching the cross rods.
9	Place wooden spacer blocks along the forks, long enough to press the cross rods against the fork dowels.
10	Position a protective plate using braces as in Figure 1-7. Be sure that the plate does not press against handles or other cabinet hardware.
11	Raise both lifter forks evenly until the equipment clears the shipping skid; pull it out of the way.
12	Wheel the equipment to the final position in the electronics room; lower it to the floor.
13	Pull out the mobile lifters. Dismantle and remove the angle iron transport skid.
14	Manually place the cabinet in the exact final position.

*Continued on next page*

# 1.4 Unpacking and Placement, Continued

Mobile lifters, continued Figure 1-7 Removal of Equipment from Shipping Skid—Part 2

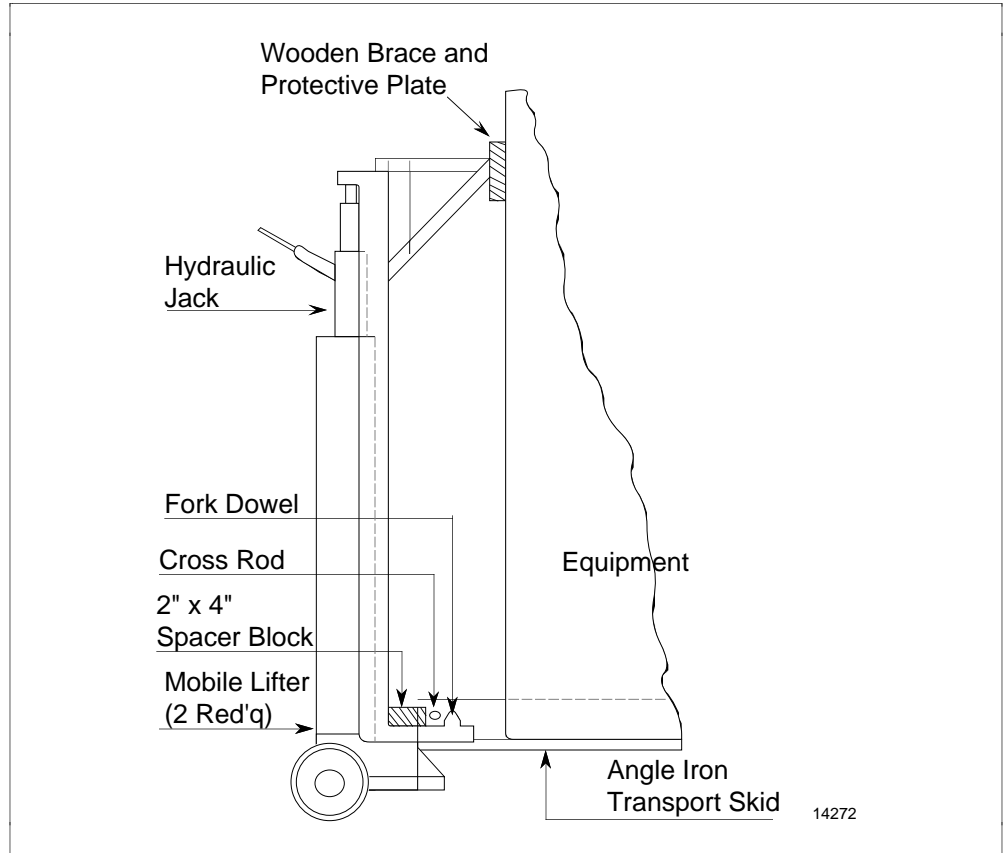

*Continued on next page*

# 1.4 Unpacking and Placement, Continued

## Mobile lifters, continued

Figure 1-8 Lifting Equipment by Mobile Lifter of Crane

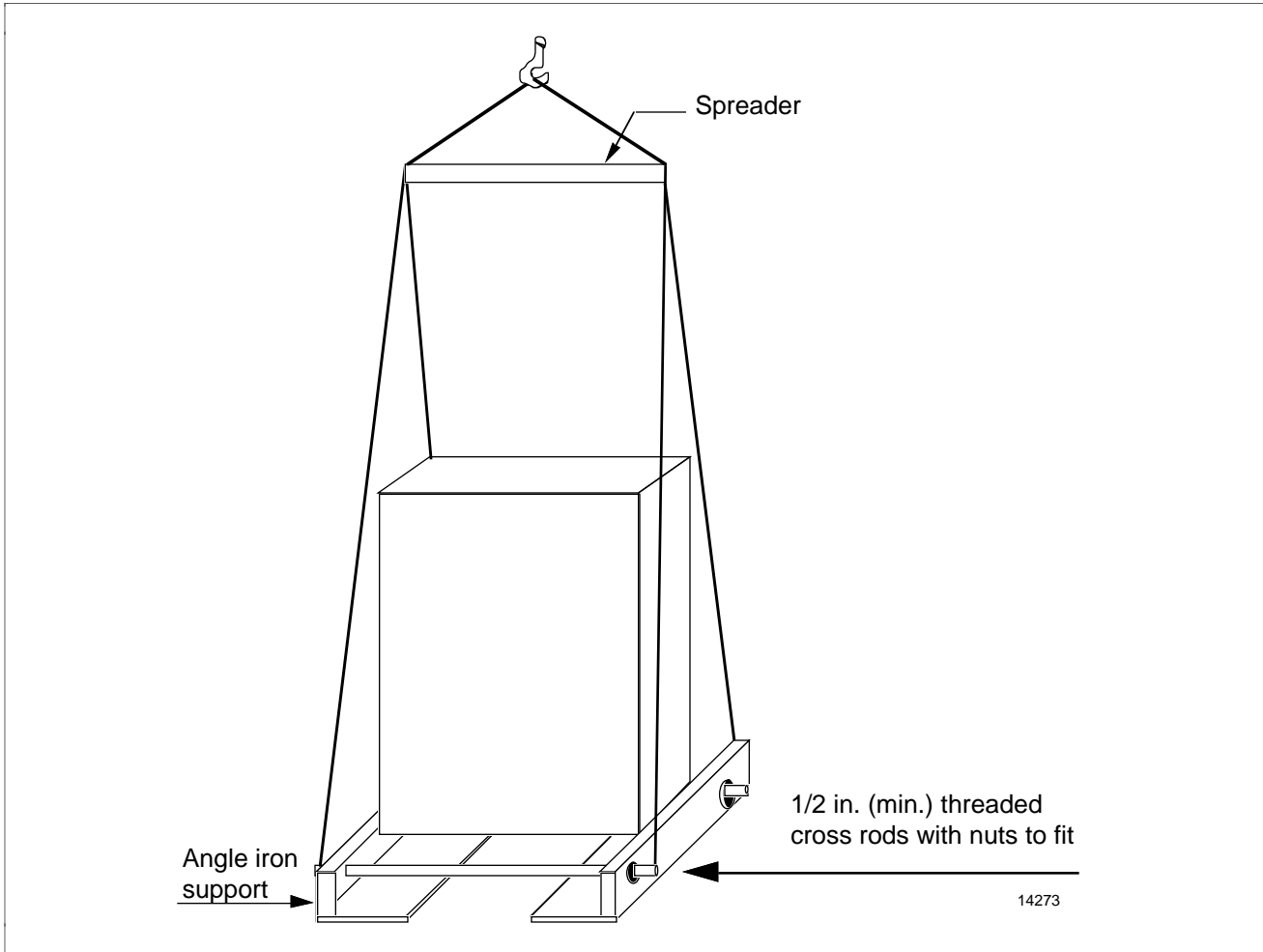

*Continued on next page*

## 1.4 Unpacking and Placement, Continued

### Roller method

As illustrated in Figure 1-9, using the roller method the Safety Manager is moved to its final destination by placing pipe rollers under a transport skid made of angle iron. Table 1-6 lists special considerations regarding the use of the roller method to move the equipment.

Table 1-6 Roller Method Considerations

Number	Consideration
1	Use one of the previous methods to move the cabinet to a location where rollers are to be used.
2	Install the angle iron transport skid as in the mobile lifter method.
3	Place 12 mm (1 inch) pipes under the transport skid as in Figure 1-9. <ul style="list-style-type: none"><li>• The load must be on the angle irons, not the cabinet.</li></ul>
4	Roll the cabinet to the final location. <ul style="list-style-type: none"><li>• At least three pipes must be under the transport skid at all times.</li></ul>
5	When the cabinet is near the final location, tilt it and pull out the pipes, the middle one last.
6	Dismantle the transport skid and position the cabinet manually to the exact final location.

Figure 1-9 Lifting Equipment by Mobile Lifter of Crane—Part 2

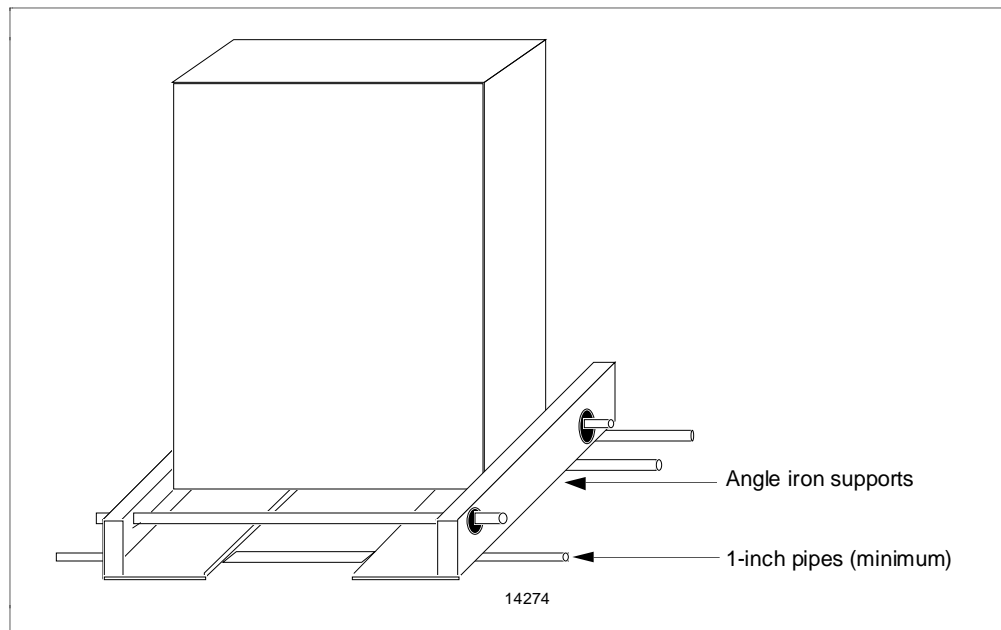

*Continued on next page*

# 1.4 Unpacking and Placement, Continued

## Crane method

In this method the cabinet is lifted into place with a crane. Use either an angle iron transport skid (Figure 1-9) or the lifting eyebolts installed on each cabinet (Figure 1-10).

Figure 1-10 Eye Bolt Crane Method

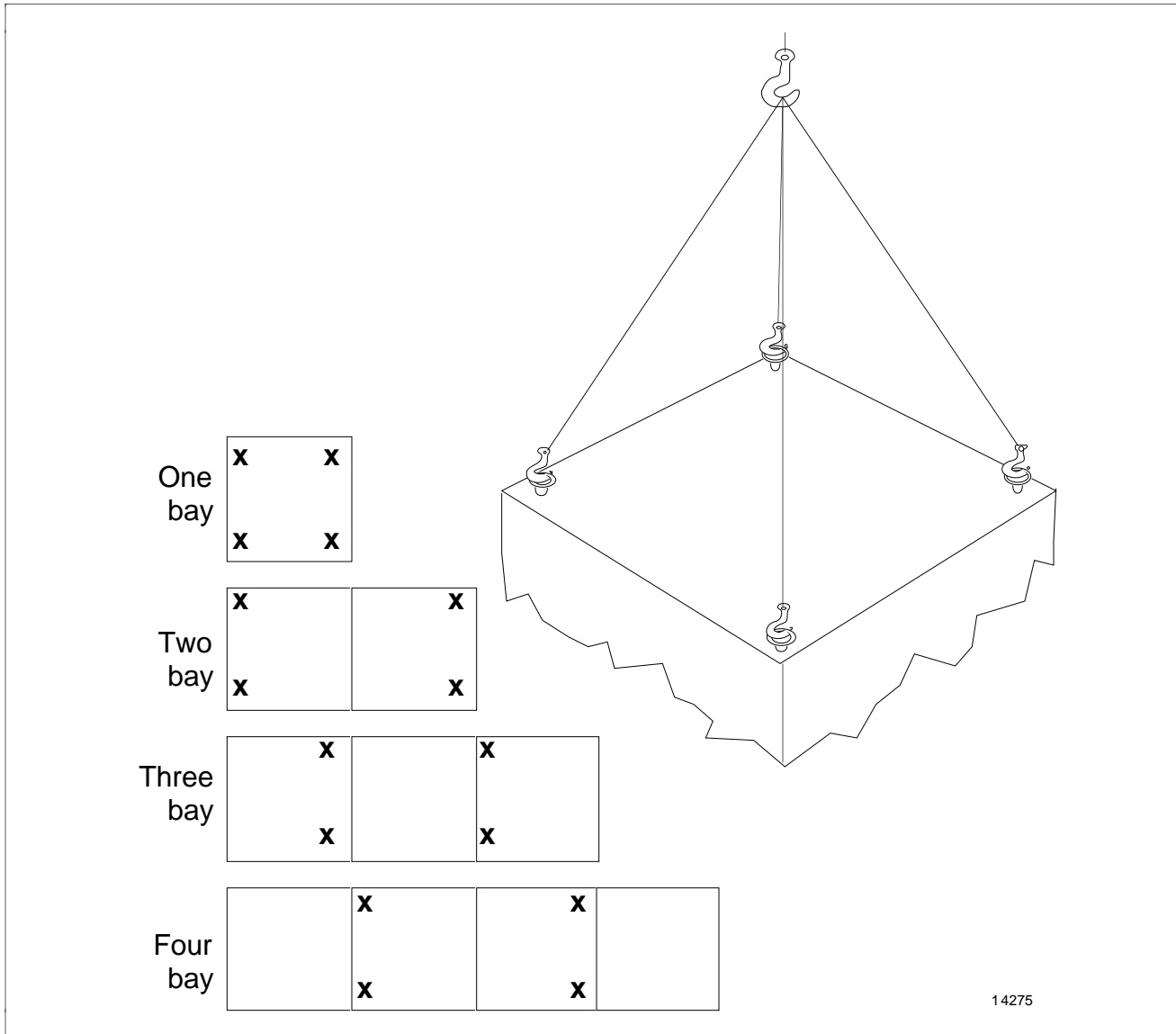

## Leveling and bolt down

Safety Manager cabinets do not include levelers; it may be necessary to hand-fit shims underneath the cabinet in order to make the cabinet sit solidly.

The SM cabinet has six holes in the bottom for bolting it to a floor. A partially filled cabinet should be bolted down. Cabinets that are bolted together are not easily moved and do not ordinarily require bolting down. Refer to Figures 1-2 through 1-5 for bolt-down dimensions.

## Section 2 – System Component Installation

### 2.1 Section Overview

#### About this section

This section provides general installation information for various components of the Safety Manager (SM) system. Topics included in this section are:

Subsection	Topic	See Page
2.1	Section Overview .....	17
2.2	Installation Considerations.....	18
2.3	Cabinet Installation.....	19
2.4	Card File Installation .....	20
2.5	Cabling and Wiring Considerations.....	21
2.6	Wiring and Cabling Installation.....	26
2.7	System Power Connections.....	34
2.8	System Ground Connections .....	36
2.9	UCN Connections.....	40

#### ATTENTION

This section describes in detail, only those installation procedures and considerations specific to the Safety Manager Module and the TDC 3000<sup>X</sup>. Installation procedures and considerations specific to the TRICON components can be located in the Triconex documentation.

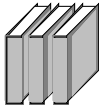

REFERENCE—For detailed information regarding

- site planning and installation, refer to SM02-550 *TDC 3000<sup>X</sup> System Site Planning Manual* in Binder TDC 3020-1 *System Site Planning-1*.
- post-installation checkout procedures, refer to SM13-500 *Safety Manager Service Manual* in this binder.

## 2.2 Installation Considerations

---

### Introduction

The Safety Manager system may encompass a single cabinet, a multi-cabinet complex, individual card files and supporting power supply modules, or a combination of such hardware.

If your SM system involves only a cabinet or cabinets, then power, ground, and cabling are brought to the system and connected. The system is configured and installation is complete.

Should your SM system not include a cabinet or cabinets, the individual chassis must be mounted to a structure and power and ground supplied by a choice of methods.

---

### Installation checklist

When installing an SM system, consider the following installation checklist:

- Carefully review all documentation available for the equipment, paying close attention to cautionary notes.
  - Install the Safety Manager system equipment in accordance with the current edition of the National Electric Code ANSI/NFPA 70.
  - Use technically qualified personnel to service the Safety Manager system components.
-

## 2.3 Cabinet Installation

---

### Introduction

After placement, the cabinet or cabinet complex requires the attachment of power and ground, cabling installation, and if necessary, configuration of certain card file modules.

**ATTENTION** Refer to Section 1—*Safety Manager System Installation* for information regarding the warehousing, movement, unpacking, and placement of the Safety Manager cabinets.

---

## 2.4 Card File Installation

---

### Introduction

The three TRICON chassis associated with the Safety Manager are identical in dimensions and necessary clearances. Their total weight is dependent upon the modules installed.

---

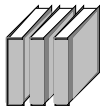

Refer to Chapter 4—*Installation and Checkout*, Subsection 4.1.3—*Mechanical Installation*, in the *TRICON Planning and Installation Guide* for information regarding the physical installation procedures and considerations of the TRICON chassis.

---

## 2.5 Cabling and Wiring Considerations

### Introduction

When installing a Safety Manager System, it is important to consider:

- conduit and tray shielding and spacing, and
- cable and wire classifications.

### Shielding

Conduit or cable trays should be used to route the network trunk line within the plant for short distances or for several miles. The same conduit should not carry both data and power wiring because of problems created by electromagnetic interference (EMI). The choice of materials and configuration for the cable conduit can determine the degree of protection from this interference.

Table 2-1, showing raceway shielding, is taken from IEEE Standard 518 for the installation of electrical equipment. It compares different types of conduits and raceways for magnetic field attenuation at 60 Hz and for electrostatic attenuation at 100 kHz.

Table 2-1 Raceway Shielding

Raceway Type	Thickness mm (in.)	60 Hz Magnetic Field Attenuation		100 Hz Magnetic Field Attenuation	
		Ratio	db	Ratio	db
Free air		1:1	0	1:1	0
2 inch aluminum conduit	3.91 (0.154)	1.5:1	3.3	2,150:1	66.5
#16 gauge aluminum tray	1.52 (0.060)	1.6:1	4.1	15,500:1	83.9
#16 gauge aluminum tray	1.52 (0.060)	3:1	9.4	20,000:1	86.0
#16 gauge galvan. iron tray	1.52 (0.060)	3.2:1	10.0	22,000:1	86.8
2 inch IPS copper pipe	3.96 (0.156)	3.3:1	10.2	10,750:1	80.6
#16 gauge aluminum tray	1.52 (0.060)	4.2:1	11.5	29,000:1	89.3
#14 gauge aluminum tray	1.90 (0.075)	6:1	15.5	23,750:1	87.5
2 inch metallic tubing	1.65 (0.065)	6.7:1	16.5	3,350:1	70.5
2 inch rigid galvanized conduit	3.91 (0.154)	40:1	32.0	8,850:1	78.9

*Continued on next page*

## 2.5 Cabling and Wiring Considerations, Continued

### Spacing

It is recommended that noise creating sources (those with time varying voltage or time varying current) be separated from data signal cable. Cables with similar levels of noise susceptibility should be grouped together, and those with similar levels of noise generation should be separately grouped in trays and conduits.

IEEE 518 defines four classes of wiring that differ in signal level and noise susceptibility as provided in Table 2-2.

Table 2-2 IEEE 518 Wiring Classification Definitions

Class	Definition
<b>Data 1</b>	High noise susceptibility. Analog signals of less than 50 V and digital signals of less than 15 V.
<b>Data 2</b>	Medium susceptibility. Analog signals greater than 50 V, regulating signals of 50 V with currents less than 20 A; ac feeders less than 20 A.
<b>Data 3</b>	Low susceptibility. Switching signals greater than 50 V, analog signals of 50 V with currents less than 20 A; ac feeders less than 20 A.
<b>Data 4</b>	Power ac and dc buses of 0-1000 V with currents of 20-800 A.

**ATTENTION** Data 3 and Data 4 classes have one subclass each for applications that require special cable and spacing. Tables 2-3, 2-4, and 2-5 in this section list the subclass for Data 3—listed as Data 3A; the subclass for Data 4 is listed as Data 4A. Examples of Data 3A and Data 4A subclass cables include

- signals from communicating fields and line resistors,
- signals from shunts to regulators, and
- power greater than 1000 volts or greater than 800 amperes, or both.

Tables 2-3, 2-4, and 2-5 list the recommended minimum distances between trays, trays and conduits, and conduits, respectively. The dimensions provided in the tables are between the top of one tray/conduit and the bottom of the tray/conduit above, or between sides of adjacent trays/conduits.

Trays containing Data 1 or Data 2 cables should have solid bottoms and covers to complete shielding. Ventilation slots or louvers may be used only in trays containing Data 3 cables.

*Continued on next page*

## 2.5 Cabling and Wiring Considerations, Continued

### Spacing, continued

Table 2-3 Tray Spacing

Cable Class	Data 1 mm (in.)	Data 2 mm (in.)	Data 3 mm (in.)	Data 3A mm (in.)	Data 4 mm (in.)	Data 4A mm (in.)
Data 1		Note 2	152.4 (6)	152.4 (6)	660.4 (26)	660.4 (26)
Data 2	Note 2		152.4 (6)	152.4 (6)	457.2 (18)	660.4 (26)
Data 3	152.4 (6)	152.4 (6)		0.0 (0)	Note 1	304.8 (12)
Data 3A	152.4 (6)	152.4 (6)	0.0 (0)		203.2 (8)	457.2 (18)
Data 4	660.4 (26)	457.2 (18)	Note 1	203.2 (8)		0.0 (0)
Data 4A	660.4 (26)	660.4 (26)	304.8 (12)	457.2 (18)	0.0 (0)	

**ATTENTION** Note the following considerations:

- Note 1
  - Data 3 and Data 4 cables may be run in a common tray but should be separated by a barrier. This barrier does not have to be grounded.
- Note 2
  - Data 1 and Data 2 cables may be in a common tray, provided they are separated by a grounded steel barrier.

Table 2-4 Tray/Conduit Spacing

Cable Class	Data 1 mm (in.)	Data 2 mm (in.)	Data 3 mm (in.)	Data 3A mm (in.)	Data 4 mm (in.)	Data 4A mm (in.)
Data 1		25.4 (1)	101.6 (4)	101.6 (4)	457.2 (18)	457.2 (18)
Data 2	25.4 (1)		101.6 (4)	101.6 (4)	304.8 (12)	457.2 (18)
Data 3	101.6 (4)	101.6 (4)		0.0 (0)	0.0 (0)	203.2 (8)
Data 3A	101.6 (4)	101.6 (4)	0.0 (0)		152.4 (6)	304.8 (12)
Data 4	457.2 (18)	304.8 (12)	0.0 (0)	152.4 (6)		0.0 (0)
Data 4A	457.2 (18)	457.2 (18)	203.2 (8)	304.8 (12)	0.0 (0)	

*Continued on next page*

## 2.5 Cabling and Wiring Considerations, Continued

### Spacing, continued

Table 2-5 Conduit Spacing

Cable Class	Data 1 mm (in.)	Data 2 mm (in.)	Data 3 mm (in.)	Data 3A mm (in.)	Data 4 mm (in.)	Data 4A mm (in.)
Data 1		25.4 (1)	76.2 (3)	76.2 (3)	304.8 (12)	304.8 (12)
Data 2	25.4 (1)		76.2 (3)	76.2 (3)	228.6 (9)	304.8 (12)
Data 3	76.2 (3)	76.2 (3)		0.0 (0)	0.0 (0)	152.4 (6)
Data 3A	76.2 (3)	76.2 (3)	0.0 (0)		152.4 (6)	228.6 (9)
Data 4	304.8 (12)	228.6 (9)	0.0 (0)	152.4 (6)		0.0 (0)
Data 4A	304.8 (12)	304.8 (12)	152.4 (6)	228.6 (9)	0.0 (0)	

### Cable, wire, and conduit selection

Select the proper cables for each type of system connection. All Programmable Logic Controller (such as the TRICON) system wires and cables can be classified into two categories:

- High level conductors
  - used to carry high voltage and/or high current,
  - typically IEEE 518 Data 2, Data 3, and Data 4 categories, and
  - include AC I/O lines; high level DC I/O lines connected to such devices as switches, relays, or solenoids; and ac power lines.
- Low level conductors
  - used to carry low voltage and/or low current,
  - typically IEEE 518 Data 1 category, and
  - include communication cables; DC I/O lines connected to solid state devices such as proximity switches or photoelectric sensors; TTL signal lines; analog signal lines; encoder signal lines; and motion control signal lines.

*Continued on next page*

## 2.5 Cabling and Wiring Considerations, Continued

### Cabling and wiring guidelines

Observe the guidelines presented in Table 2-6 when you route cables to the Safety Manager and its remote enclosures. Pay special attention to separating data cables from power cables to avoid electrical noise problems.

Table 2-6 Cabling and Wiring Guidelines

Consideration	Description
1	Maintain a 60°C (140°F), or less, ambient air temperature at the bottom of each Safety Manager system card file.
2	Do all wiring according to IEEE Standard 518-1977.
3	When you use a wire duct less than 3.5 inches deep, allow at least 1.5 inches between it and the rack assembly. For a wire duct greater than 3.5 inches deep, allow clearance of 2 inches.
4	Separate all 440 Vac (or higher) electrical supply lines as far from Safety Manager System components as possible. See Tables 2-3, 2-4, and 2-5 for the recommended minimum distances.
5	Run all 440 Vac lines in separate conduits from I/O wiring ducts.
6	Separate all ac and low level dc wiring. See Tables 2-3, 2-4, and 2-5 for the recommended minimum distances.
7	When 8 inch deep enclosures are used, door stiffeners are not permitted in front of the Safety Manager system components.
8	Shields of data communications cables must be terminated at both ends. Shields of analog signal cables must be terminated to ground only at the signal source. If a termination is not made, or is intermittent, noise immunity is lost.
9	Module thumbscrews must be tightened to ensure proper grounding for the signal shield connections.
10	Data and power cables should cross at right angles and not run in parallel for any distance.
11	Ensure that the entire communications network system is grounded to earth ground.
12	Maintain shield continuity. Ensure that shield leads are not broken.
13	Route cables around rather than through high noise areas.

## 2.6 Wiring and Cabling Installation

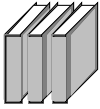

### Card file to card file cabling

---

REFERENCE—For information regarding general wiring and cabling considerations, refer to Subsection 2.4—*Cabling and Wiring Considerations*.

---

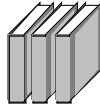

Refer to the following references in your Triconex documentation.

- For considerations and specifications regarding the I/O bus cabling between chassis, refer to
  - Chapter 2—*Basic Components*, Subsection 2.2—*I/O Expansion*, in the *TRICON Planning and Installation Guide*
  - Chapter 4—*Installation and Checkout*, Subsection 4.1.7—*Connecting Chassis with the I/O Bus*, in the *TRICON Planning and Installation Guide*
  - Appendix D—*Pin-Outs for TRICON Connectors*, Subsection D.3—*I/O Bus Cable for Interconnected Chassis*, in the *TRICON Planning and Installation Guide*
- For special considerations and specifications regarding RXM chassis, refer to Chapter 6—*Using Remote Extender Chassis* in the *TRICON Planning and Installation Guide*
- For recommended wiring methods, refer to Appendix F—*Recommended Wiring Methods*, in the *TRICON Planning and Installation Guide*

---

*Continued on next page*

## 2.6 Wiring and Cabling Installation, Continued

### SMM cabling

Figure 2-1 illustrates the frontplate of the Safety Manager Module (SMM). Connections to the UCN are made via the two UCN F-style connectors in the center of the module.

Figure 2-1 SMM Frontplate

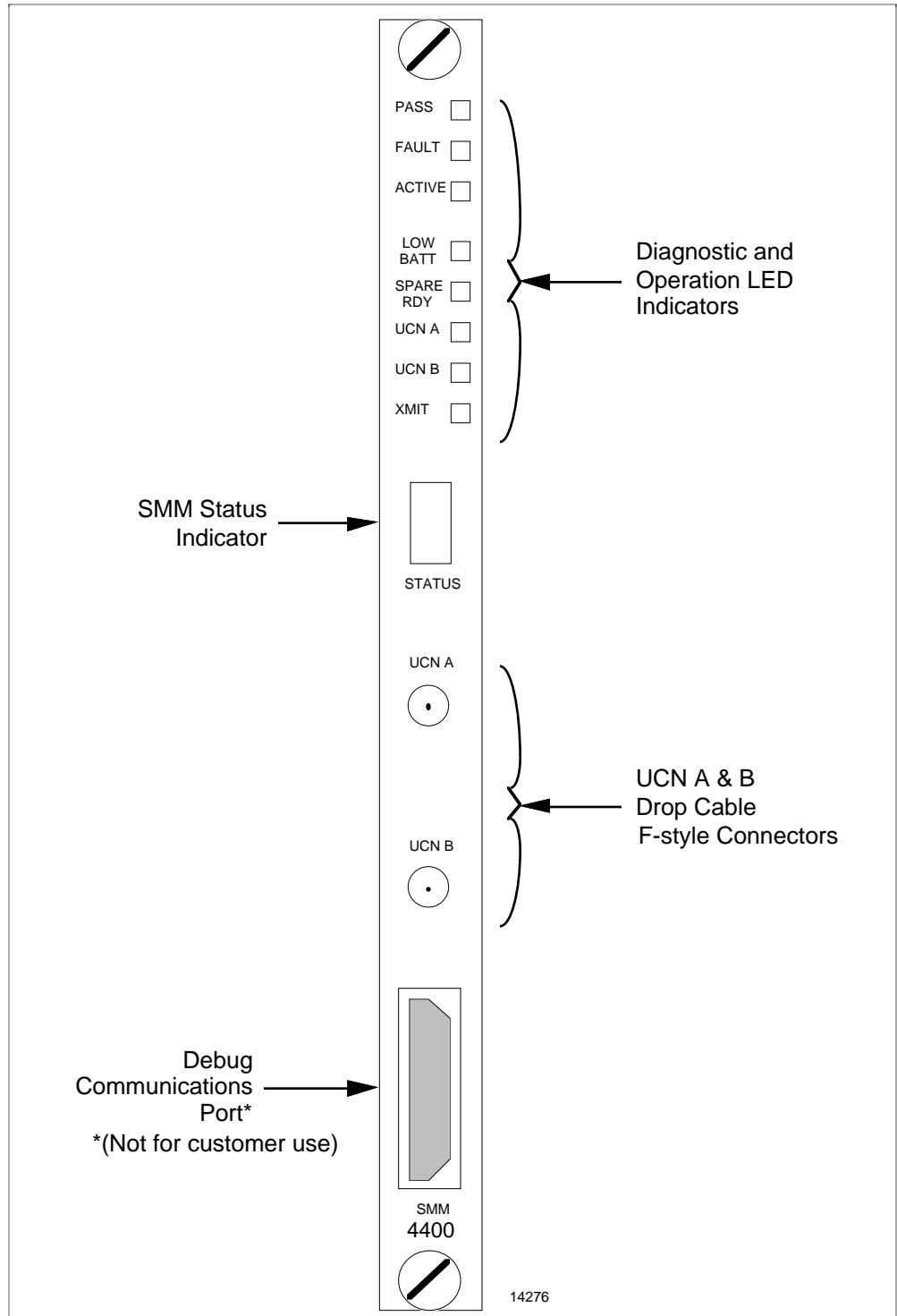

*Continued on next page*



## 2.6 Wiring and Cabling Installation, Continued

### SMM cabling, continued

Figure 2-3 illustrates the UCN cabling required of a redundant Safety Manager system.

In this case two SMM modules are installed, one each in the center and right-hand physical slots of a TRICON's logical slot. RG-6 UCN drop cables are run from the drop ports on UCN A to UCN A F-style connectors of each SMM. RG-6 UCN drop cables are also run from the drop ports on UCN B to UCN B F-style connectors of each SMM.

Figure 2-3 Redundant SM UCN Cabling

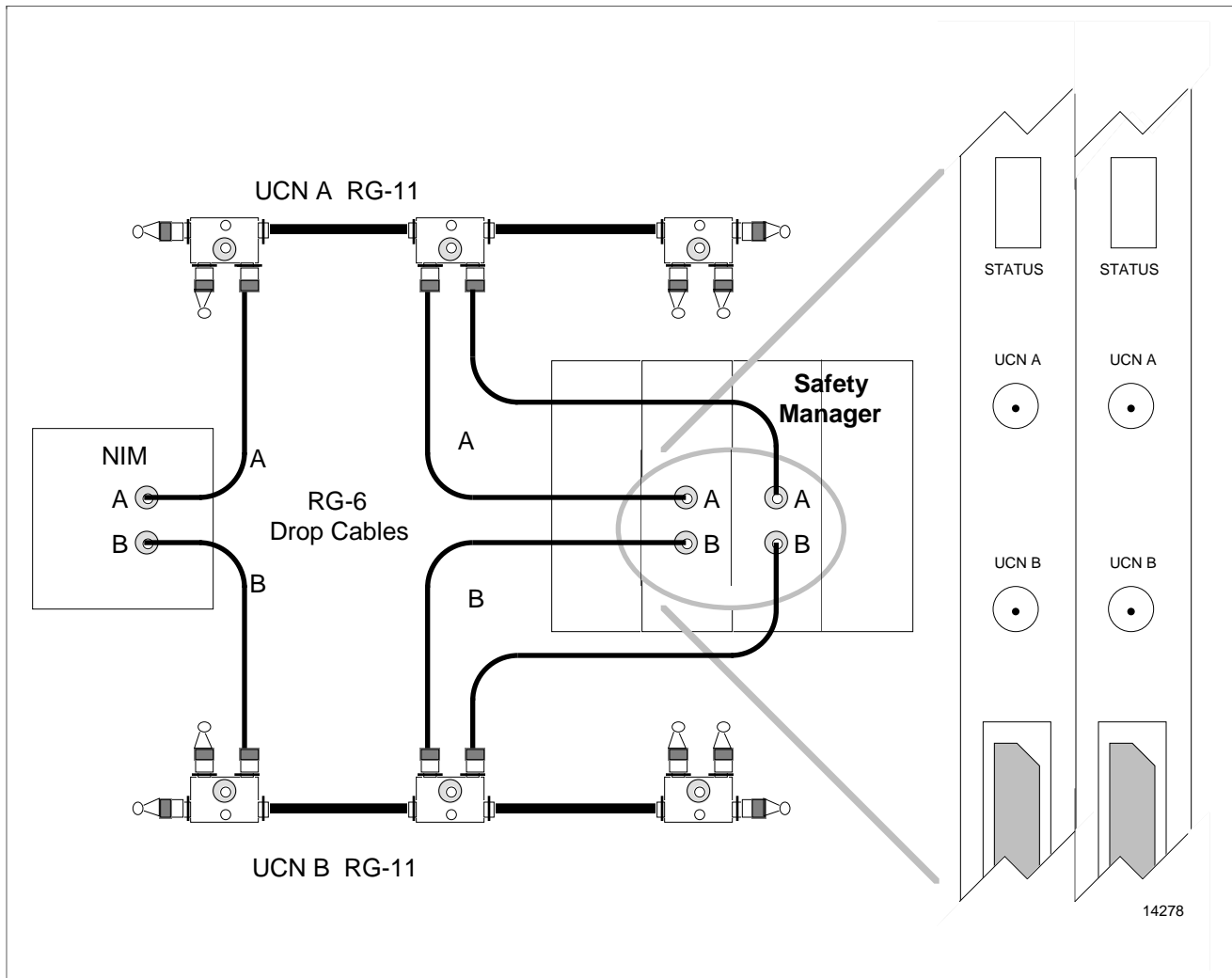

**CAUTION** Remove UCN cable from SMM port, without breaking UCN cable continuity, or communication will be lost to other UCN devices.

*Continued on next page*

## 2.6 Wiring and Cabling Installation, Continued

### Power supply wiring

---

**ATTENTION** For information regarding the wiring of the Safety Manager card file power supply modules, refer to Subsection 2.7—*System Power Connections*, in this section.

---

### I/O module wiring

Field wiring is not connected directly to the I/O modules themselves. Rather, as illustrated in Figures 2-4 and 2-5, these connections are made via Field Termination Assemblies (FTA) available as either an

- Internal Termination Module which
  - is used for high-density applications,
  - resides in the left-most physical slot of the logical slot containing the I/O module(s), and
  - are specified for a given I/O module.
- External Termination Module which
  - permits remote terminal panel-based wiring connections,
  - connects via a cable bundle(s) to an interface module residing in the left-most physical slot of the logical slot, and
  - are specified for a given I/O module.

The FTAs are electrically passive devices which simply pass incoming or outgoing signals between the field and the I/O module. A separate Logical Slot Bus in each logical slot permits the I/O module(s) to communicate with the termination module.

**ATTENTION** Installation considerations specifically concerning power and ground connections can be located in Subsection 2.8—*System Ground Connections*.

Figure 2-4 illustrates an example of the typical layout of two logical slots utilizing the Internal Termination Module and the Interface Module for the External Termination Module.

---

*Continued on next page*

## 2.6 Wiring and Cabling Installation, Continued

I/O module wiring,  
continued

Figure 2-4 I/O Module Set Termination Examples

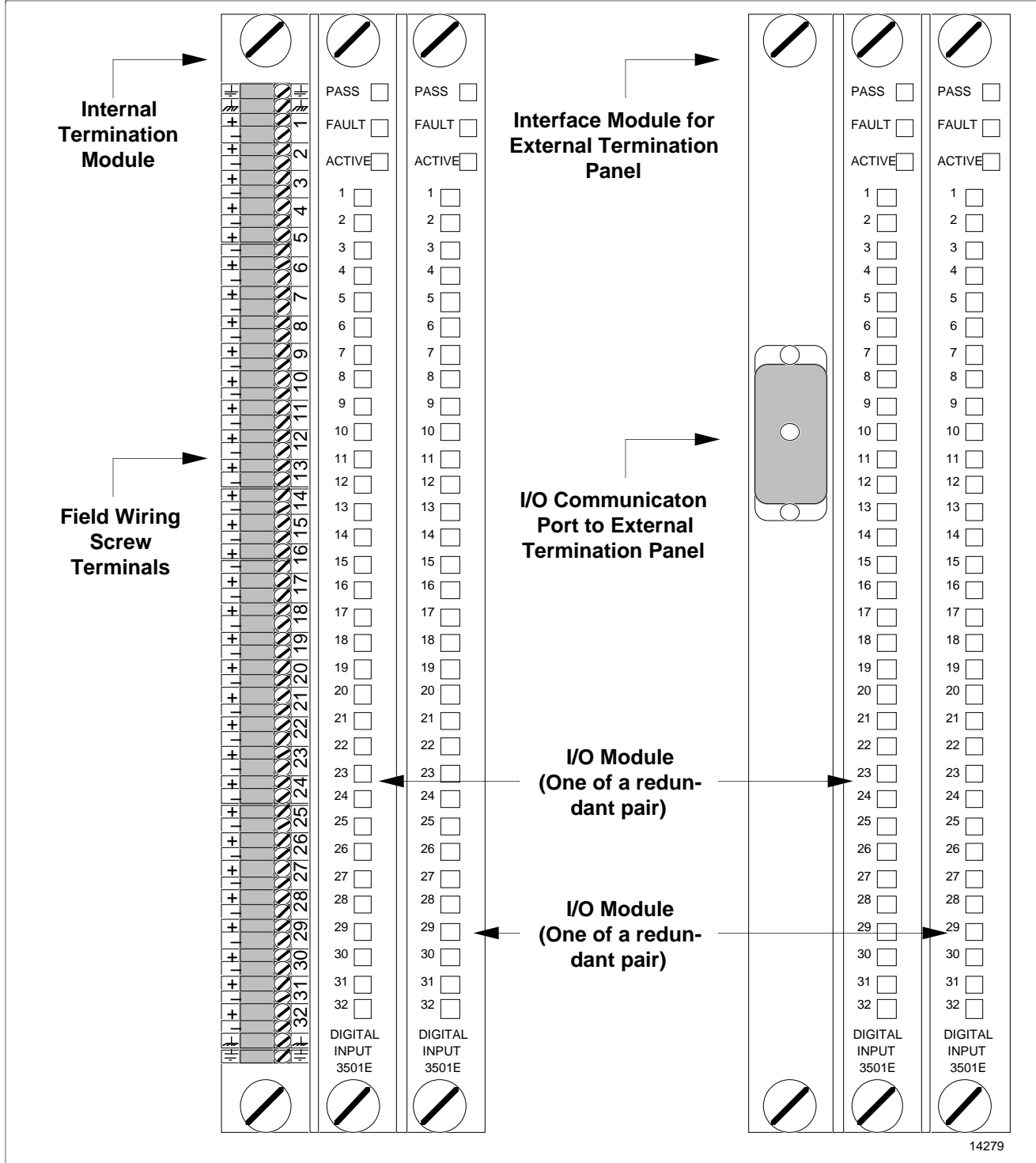

Continued on next page

## 2.6 Wiring and Cabling Installation, Continued

I/O module wiring,  
continued

Figure 2-5 illustrates an example of the type of External Termination Module employed by the TRICON.

Figure 2-5 External Termination Module Example

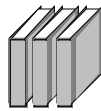
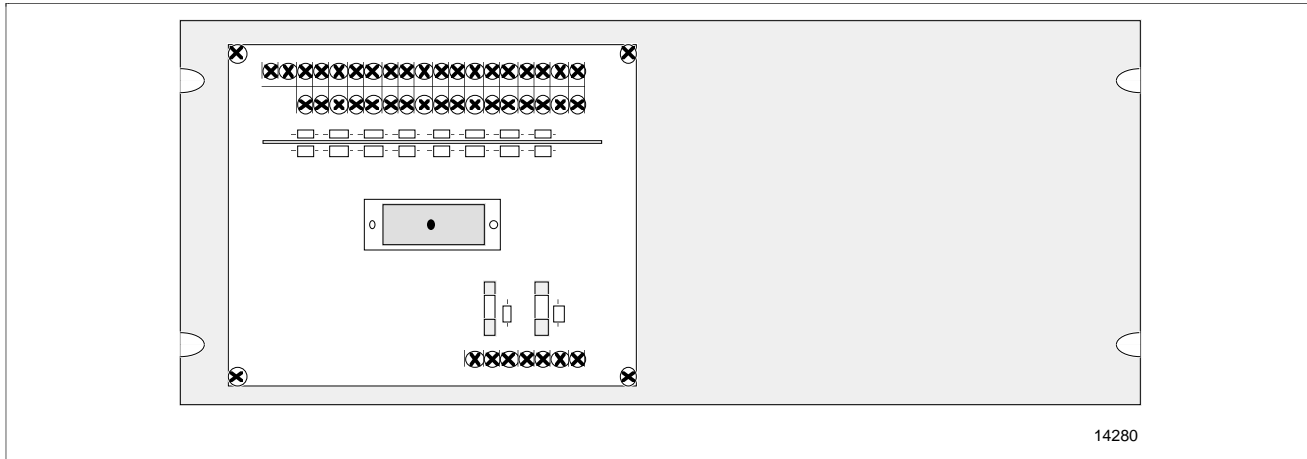

Refer to the following references in your Triconex documentation.

- For I/O module specifications, refer to appropriate module in Chapter 3—*Selectable Modules*, Subsection 3.1 through 3.6 in the *TRICON Planning and Installation Guide*.
- For field wiring precautions, refer to Chapter 4—*Installation and Checkout*, Subsection 4.1.11—*Output Voter Diagnostics—Field Wiring Precautions*, in the *TRICON Planning and Installation Guide*.
- For recommended wiring methods, refer to Appendix F—*Recommended Wiring Methods*, in the *TRICON Planning and Installation Guide*.
- For field termination modules, refer to the *User's Manual for Field Terminations*.

*Continued on next page*

## 2.6 Wiring and Cabling Installation, Continued

---

### Communication module wiring

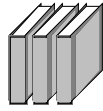

Refer to the following references in your Triconex documentation.

- For I/O module specifications, refer to appropriate module in Chapter 3—*Selectable Modules*, Subsection 3.7 through 3.10 in the *TRICON Planning and Installation Guide*.
- For recommended wiring methods, refer to Appendix F—*Recommended Wiring Methods*, in the *TRICON Planning and Installation Guide*.

**ATTENTION** For information specific to the wiring of the Safety Manager Module, refer to “SMM Cabling” in this subsection.

---

### TRISTATION cabling

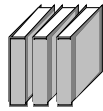

Refer to the following references in your Triconex documentation.

- For TRISTATION cabling information, refer to
    - Chapter 4—*Installation and Checkout*, Subsection 4.1.9—*Connecting to the TRISTATION PC*, in the *TRICON Planning and Installation Guide*
    - Chapter 6—*Installation and Checkout*, Subsection 6.1.2—*Configuring the TRISTATION for RXM Chassis*, in the *TRICON Planning and Installation Guide*
    - Appendix D—*Pin-Outs for TRICON connectors*, Subsection D.1—*TRICON-to-TRICON Cable*, and Subsection D.2—*25-Pin to 9-Pin Adapter*, in the *TRICON Planning and Installation Guide*
  - For recommended wiring methods, refer to Appendix F—*Recommended Wiring Methods*, in the *TRICON Planning and Installation Guide*.
-

## 2.7 System Power Connections

### Cabinet power connections

Figure 2-6 illustrates the power connections for a Safety Manager cabinet.

Conductors and breakers, used to supply power to the cabinet, are sized using rules in the *Site Planning* manual. Refer to your site planning drawings and this figure to install power.

A cabinet will have a circuit breaker box with either two or six dual 15-ampere circuit breaker boxes at the bottom of the cabinet. Each circuit breaker services a single card file.

**CAUTION** Do not use circuit breakers larger than 15 amperes; the power supply subassembly is not rated for larger circuit breakers.

Figure 2-6 Safety Manager Cabinet Power and Ground Connections

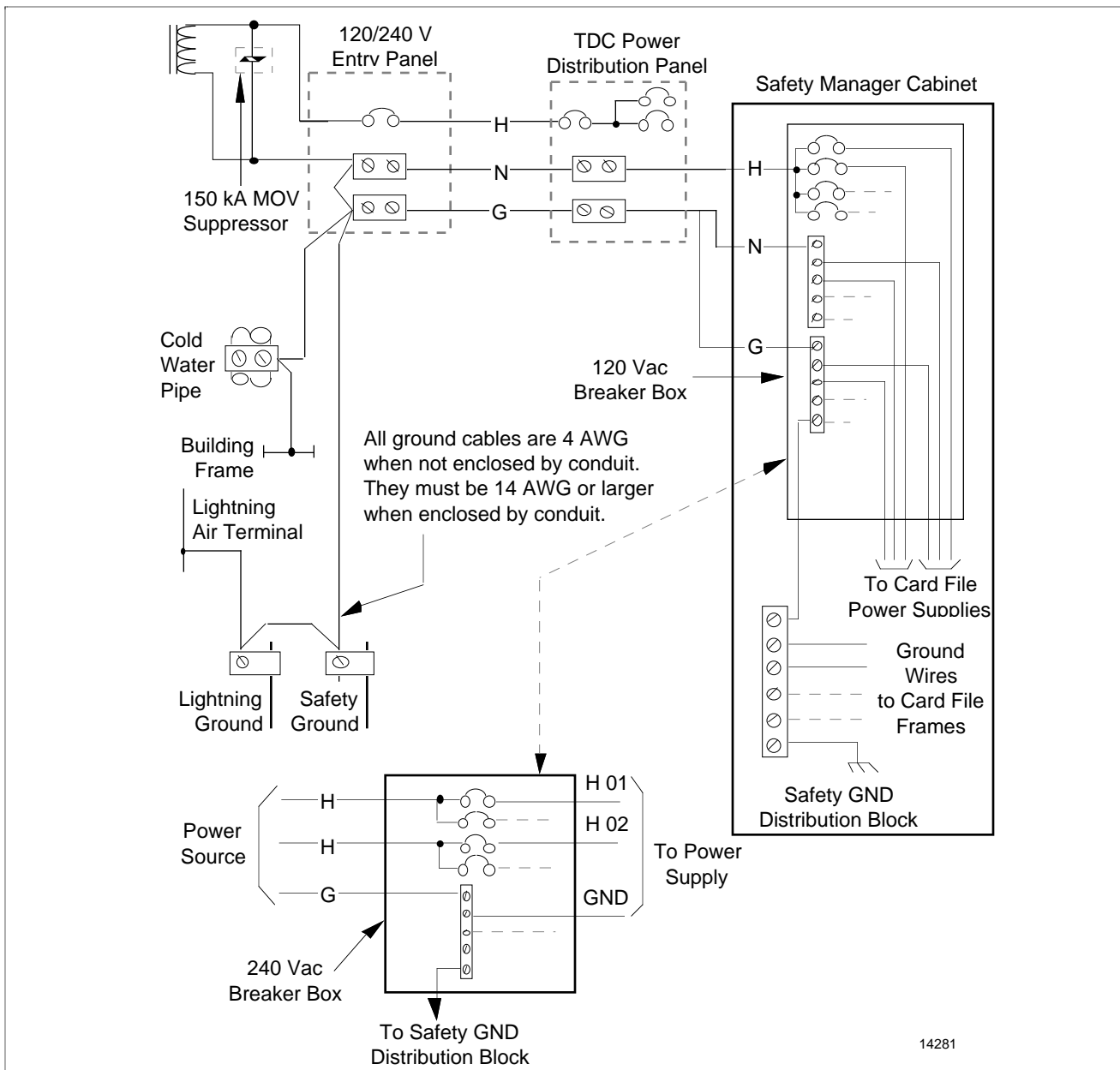

Continued on next page

## 2.7 System Power Connections, Continued

---

### Card file power connections

Power is supplied to each Safety Manager card file (chassis) by connecting each power supply module in accordance to the specifications and techniques stipulated by Triconex.

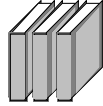

For information regarding the wiring of the Safety Manager card file power supply modules

- to their source supply, refer to Chapter 4—*Installation and Checkout*, Subsection 4.1.1—*Connecting the Power Modules*, in the *TRICON Planning and Installation Guide*.
  - alarm contacts, refer to
    - Chapter 2—*Basic Components*, Subsection 2.3.3—*Alarm Description*, in the *TRICON Planning and Installation Guide*
    - Chapter 4—*Installation and Checkout*, Subsection 4.1.2—*Alarm Wiring*, in the *TRICON Planning and Installation Guide*
-

## 2.8 System Ground Connections

### Background

The Safety Manager cabinets, card files (chassis), termination panels, communications equipment, and field wiring must be properly grounded to ensure correct and safe operation. This subsection provides the necessary information needed to make these connections.

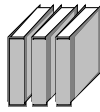

For basic information regarding the TRICON's grounding requirements, refer to Chapter 4—*Installation and Checkout*, Section 4.3—*Grounding the TRICON Properly*, Subsection 4.3.1—*The TRICON's Ground Systems* in the *TRICON Planning and Installation Guide*.

### Grounding considerations

Adequate grounding is important for safety considerations and for reducing electromagnetic noise interference. All earth ground connections must be permanent and provide a continuous low impedance path to earth ground for induced noise currents and fault currents. Table 2-7 lists the steps to be performed when grounding your system.

Table 2-7 System Grounding Considerations

Step	Action
1	<p>Use the system grounding techniques described in this subsection and those defined in the Triconex documentation before making ground connections. Establish</p> <ul style="list-style-type: none"><li>• AC safety ground by making a<ul style="list-style-type: none"><li>– temporary connection using the grounding terminal on front of each power supply module, and</li><li>– permanent, redundant connection to safety ground attaching No. 8 AWG from ground to each card file using a crimped ring lug and 1/4" bolt.</li></ul></li><li>• signal ground by tying together the signal ground and safety ground at <u>one</u> and <u>only one</u> point.</li><li>• shield ground by connecting one end of the shield of each field cable between an analog termination panel and analog field device.</li></ul>
2	Select the proper voltage (115 Vac or 230 Vac) for all configurable modules before supplying power to the system.
3	Securely fasten all cover plates in order to maintain system integrity and to ensure system grounding.

*Continued on next page*

## 2.8 System Ground Connections, Continued

**Grounding considerations, continued**

Table 2-7 System Grounding Considerations, Continued

Step	Action
4	Ensure that cover plates are installed over all blank slots. (The cover plates supplied with Safety Manager system card files and modules shield the electronics from electromagnetic noise.)
5	Firmly tighten all thumbscrews on module front plates and cover plates.
6	Consult IEEE Standard 518-1977, the National Electric Code, and the Subsections 2.5 and 2.6 of this document before wiring the system components.

**Cabinet ground connections**

Figure 2-6 illustrates the power and ground connections for a Safety Manager cabinet.

Ground wires from each card file in the cabinet are collected at a bus bar located at the bottom of the cabinet. This bus bar must be connected to building safety ground with a 1.67 mm (14 AWG) wire in conduit or a 5.3 mm (4 AWG) wire without conduit. Each cabinet must be connected individually to building safety ground and not daisy-chained with other cabinets or equipment.

*Continued on next page*

## 2.8 System Ground Connections, Continued

### Safety ground

The Safety Manager card files (TRICON chassis) and external termination panels must be properly connected to safety ground in accordance to the specifications and techniques stipulated by Triconex.

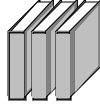

Refer to the following references in your *TRICON Planning and Installation Guide*.

- For general background information regarding safety ground, refer to Chapter 4—*Installation and Checkout*, Section 4.3—*Grounding the TRICON Properly*, Subsection 4.3.2—*Why Safety Ground is Necessary*.
- For information regarding safety ground connections for the card files (chassis), refer to Chapter 4—*Installation and Checkout*, Section 4.3—*Grounding the TRICON Properly*, Subsection 4.3.3—*Connecting Chassis to AC Safety Ground*.
- For information regarding safety ground connections for external termination panels, refer to Chapter 4—*Installation and Checkout*, Section 4.3—*Grounding the TRICON Properly*, Subsection 4.3.4—*Connecting External Termination Panels to AC Safety Ground*.

### Signal ground

The Safety Manager card files (TRICON chassis) internal signal ground floats with respect to safety ground. To insure proper operation of the SM, signal ground must be configured in accordance to the specifications and techniques stipulated by Triconex.

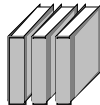

For detailed information regarding the connection of signal ground for specific system configurations, refer to Chapter 4—*Installation and Checkout*, Section 4.3—*Grounding the TRICON Properly*, Subsection 4.3.5—*Connecting the TRICON to Signal Ground*.

*Continued on next page*

## 2.8 System Ground Connections, Continued

---

### Shield ground

Field wiring between analog field devices for both the internal and external termination panels must be properly connected to shield (earth) ground. To insure proper communication over these links, shield ground must be configured in accordance to the specifications and techniques stipulated by Triconex.

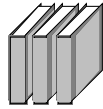

For detailed information regarding the connection of shield (earth) ground, refer to Chapter 4—*Installation and Checkout*, Section 4.3—*Grounding the TRICON Properly*, Subsection 4.3.7—*Connecting Shields to Earth Ground*.

---

### Communication equipment grounding

Communication equipment connected to the Safety Manager must be grounded in accordance to the specifications and techniques stipulated by Triconex.

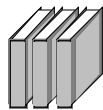

For information regarding the grounding of communication equipment, including the TRISTATION, refer to Chapter 4—*Installation and Checkout*, Section 4.3—*Grounding the TRICON Properly*, Subsection 4.3.6—*Communication Equipment Grounding* in the *TRICON Planning and Installation Guide*.

---

## 2.9 UCN Connections

---

**Node address selection** Unlike other UCN devices, the UCN node address is configured via the TRISTATION and becomes slot dependent.

---

**UCN installation** The installation procedure and cabling information can be found in the *UCN Site Planning and Installation* manual in the *UCN Site Planning and Installation* binder.

Figure 2-7 illustrates a typical UCN installation. Connection of the UCN system is made at the front panel of the Safety Manager Module.

**ATTENTION** For detailed information regarding the connection of the UCN to the Safety Manager, refer to Subsection 2.6—*Wiring and Cabling Installation* under the topic, “SMM Cabling,” in this document.

---

*Continued on next page*

## 2.9 UCN Connections, Continued

### UCN installation, continued

Figure 2-7 Connection of the UCN

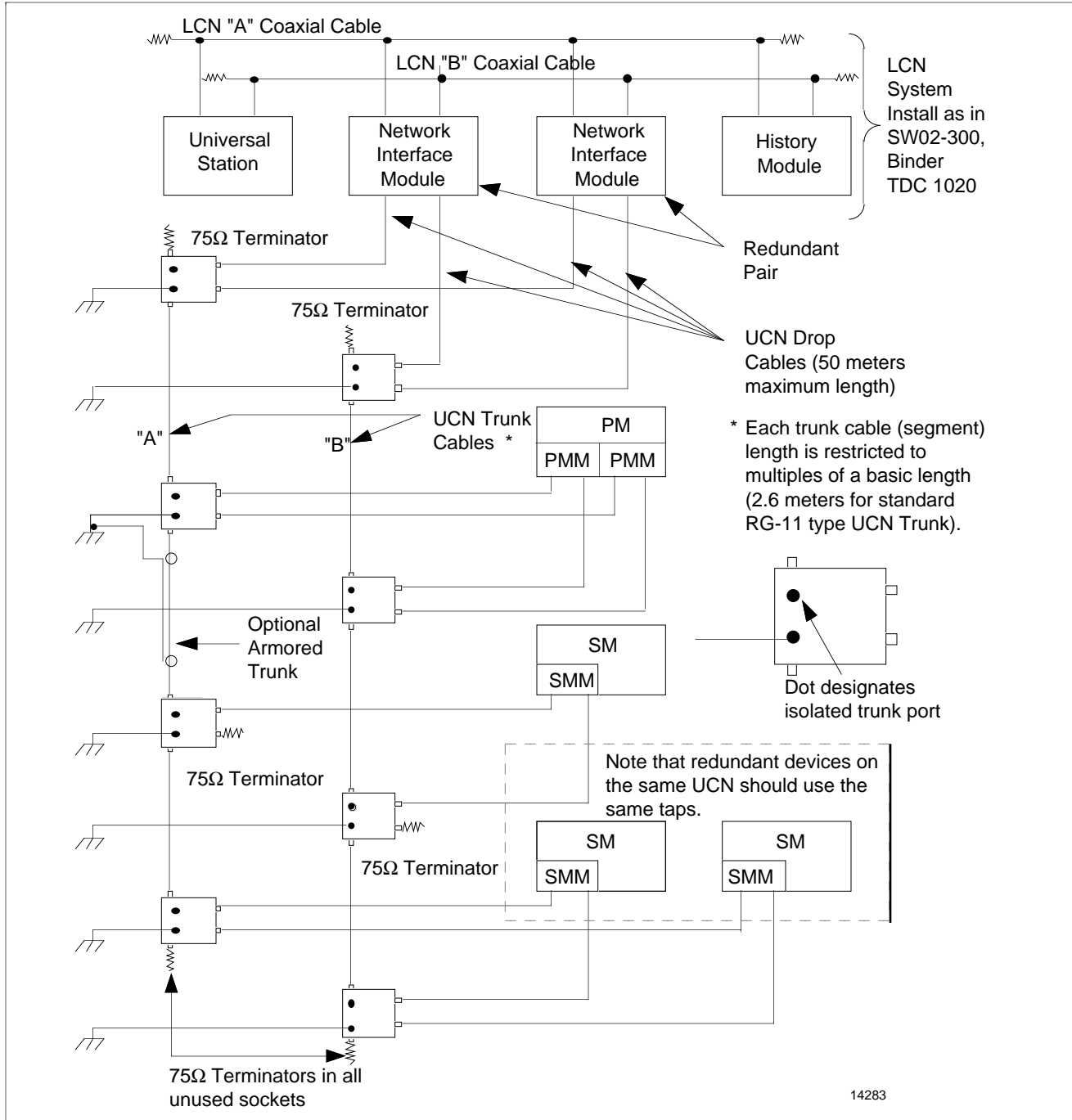

Continued on next page

## 2.9 UCN Connections, Continued

---

**Trunk cable connection** Connection of the UCN trunk lines are made at the front panel of the Safety Manager Module. Refer to Figure 2-3 for more detail. Use the procedure that is found in the *TDC 3000<sup>X</sup> System Site Planning* manual as the installation guide.

---

## Section 3 – System Component Configuration

### 3.1 Section Overview

---

**About this section**

This section provides general installation information for various components of the Safety Manager (SM) system. Topics included in this section are:

Subsection	Topic	See Page
3.1	Section Overview .....	43
3.2	System Configuration Overview.....	44
3.3	Card File Configuration.....	45

**ATTENTION**

This section describes in detail, only those installation procedures and considerations specific to the Safety Manager Module and the TDC 3000<sup>X</sup>. Installation procedures and considerations specific to the TRICON components can be located in the Triconex documentation.

---

## 3.2 System Configuration Overview

---

### Introduction

The Safety Manager (SM) system consists of a TRICON Programmable Logic Controller (PLC) outfitted with a single or redundant pair of Safety Manager Modules (SMMs).

The TRICON's main chassis card file contains the PLC's triplicated main processors and some mix of I/O and communications modules. Typically, the SMM(s) also reside in the main chassis, but may be located in either an expansion or RXM chassis. The SM also supports a dual-redundant SMM configuration for load dividing.

---

### Redundant SMM modules

The SM can be configured for either non-redundant or redundant operation depending on the number of SMM modules employed. In a redundant configuration, two SMMs are installed in adjacent physical slots of any compatible logical slot.

In this configuration, each SMM is independently connected to the UCN. One of the two will function as the primary, carrying out all UCN to SM communication and data transfer operations. The other SMM will function as the secondary or backup link between the UCN and TRICON. A separate private link is established between the two SMMs via the logical slot's independent backplane. Database synchronization and status and control transfers occur over the private link; the UCN is used as backup.

---

## 3.3 Card File Configuration

---

### Introduction

The Safety Manager has three chassis categories which are as follows:

- Main chassis
  - Expansion chassis
  - Remote expansion chassis
- 

### Main chassis

The main chassis (card file) includes several standard items such as the redundant chassis power supplies, keyswitch, and Main Processor modules. It also has four logical slots (excluding those reserved for the main processors) in which can be installed:

- communication modules (such as the SMM),
- I/O modules,
- hot-spare I/O modules, and
- termination modules.

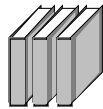

Refer to the following references in your Triconex documentation for detailed main chassis configuration requirements.

- For modules/slot compatibility and configuration, refer to Chapter 2—*Basic Components*, Section 2.1—*Main and Expansion Chassis*, in the *TRICON Planning and Installation Guide*.
  - For information regarding the configuration of the I/O module identification keys, refer to Chapter 4—*Installation and Checkout*, Section 4.1—*Recommended Installation Procedures*, Subsection 4.1.5—*I/O Module Identification Keys* in the *TRICON Planning and Installation Guide*.
  - For information regarding the configuration of the chassis I/O bus address, refer to
    - Chapter 4—*Installation and Checkout*, Section 4.1—*Recommended Installation Procedures*, Subsection 4.1.5—*I/O Bus Address of TRICON Chassis* in the *TRICON Planning and Installation Guide*
    - Configuration using the TRISTATION. Refer to the *TRISTATION MSW User's Manual*
- 

### Expansion chassis

The expansion chassis includes I/O modules and its own set of redundant power supplies. Each chassis has six RS-485 I/O expansion bus ports for passing data to two other chassis.

---

*Continued on next page*

### 3.3 Card File Configuration, Continued

---

#### RXM chassis

The fiber-optic remote extender module (RXM) is for operation of expansion chassis up to 2 kilometers (1.2 miles) away from the main chassis.

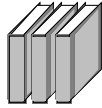

For more information on expansion and RXM chassis, refer to Triconex's *TRICON Planning and Installation Guide*.

---

# Section 4 – Configuration

## 4.1 Section Overview

### About this section

This section provides general information for various software configuration procedures for the Safety Manager (SM) system. Topics included in this section are:

Subsection	Topic	See Page
4.1	Section Overview .....	47
4.2	TRISTATION UCN Configuration.....	48
4.3	SOE Configuration .....	53
4.4	US Configuration.....	56

### Introduction

There are four areas which need to be configured to properly use the Safety Manager. These are as follows:

- TRICON relay ladder logic programming,
- TRISTATION configuration for the UCN,
- Sequence of Events (SOE) configuration, and
- Universal Station configuration for SMM points.

This section will focus primarily on the TRISTATION configuration for UCN, SOE configuration and US configuring of SMM points.

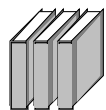

For information on TRICON relay ladder logic programming, refer to the Triconex *TRISTATION MSW User's Manual*.

### Preconfiguration assumptions

This section assumes the following steps have been completed:

- The TRISTATION hardware (i.e. cabling) has been properly connected.

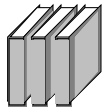

Refer to wiring section of this manual.

- The TRISTATION software has been successfully loaded onto the PC.

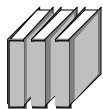

Refer to the Triconex *TRISTATION MSW User's Manual*.

### Version needed for configuration

In order to successfully configure the SM system, you will need to be using version 8 of Triconex TRICON software and release 500 for the TDC 3000<sup>X</sup> system.

## 4.2 TRISTATION UCN Configuration

### Configuring for the UCN at the TRISTATION

In order to ensure that the Safety Manager is synchronized with other devices on the UCN and its SOE capabilities are available, the SM must have the UCN address configured at the TRISTATION. Tables 4-1 and 4-2 outline this procedure. Use Figure 4-1 as a visual reference.

Table 4-1 Getting to the TRISTATION UCN Configuration Screen

Step	Action
1	Bring up your TRICON software by typing <code>ts32</code> on your PC. The FILE MANAGER display will be the first screen you view after entering the correct password level.  <b>ATTENTION</b> Make sure the [NUM LOCK] key is off first.
2	Press the [ALT 3] keys. You should now be in the MODULE CONFIGURATOR screen.
3	Determine your desired SMM configuration in chassis.  <b>ATTENTION</b> It is possible to have two redundant (four) SMMs configured for a Safety Manager system. SMMs can be configured for slots 5, 6 and 9, 10 in chassis 1 or chassis 2. There are configuration restrictions which apply.
4	Use the [F7 PREV SLOT] and [F8 NEXT SLOT] keys to move from previous to next slots in the chassis. Once you have reached the slot you wish to configure, press the [F6 CONFIG MODULE].
5	Use the arrow keys to locate and highlight SMM under Module Selections on the screen. Click on the [F1 ADD MODULE ] key. An SMM configuration window will come up.
6	Using the arrow keys to highlight the parameter you want, configure as desired and press the [ENTER] key.  <b>ATTENTION</b> Table 4-2 lists the configuration parameters in detail.
7	Press the [ESC] key to exit out of configuration window once configuration is complete.

*Continued on next page*



## 4.2 TRISTATION UCN Configuration, Continued

### TRISTATION UCN configuration parameters

Table 4-2 lists the TRISTATION UCN configuration parameters and their corresponding functional descriptions.

Table 4-2 TRISTATION UCN Configuration Parameters

Parameter	Description
Node address	<p>This is the address of the SM node on the UCN. This number <u>must</u> match the node number assigned when using the US to configure SMM data points for the same SM device. Enter in an odd number from 1 to 63.</p> <p><b>ATTENTION</b> Odd numbered addresses are reserved for active modules and even addresses for hot spare modules. Up to 32 redundant devices are supported by the UCN. Dual redundant SMMs should have different UCN addresses.</p>
SOE block	<p>You must answer with 15 or 16 if you wish to collect SOE data from the TRICON.</p> <p><b>ATTENTION</b> SOE blocks 15 and 16 are for the SMM only. Note that if you have two redundant SMMs configured in the same chassis, they <u>cannot</u> be the same SOE block number. If one is 15 the other must be 16.</p>
Prohibit writes	<p>Answer NO if you wish to allow writes to be made to the TRICON from the Universal Station. If not, answer YES.</p>
UCN test mode	<p>Answer NO to disable factory test mode.</p> <p><b>ATTENTION</b> A YES answer should be used only by Honeywell factory test personnel.</p>
MP Clock	<p>An answer YES means you want this pair of SMMs to update the TRICON with the UCN time. You must answer YES if you plan to configure SMM digital input points for use with the SOE application.</p> <p><b>ATTENTION</b> If you have two redundant SMMs configured on the same chassis, you can answer YES for only <u>one</u> of the logical pairs.</p>

*Continued on next page*

## 4.2 TRISTATION UCN Configuration, Continued

### Saving TRISTATION UCN configuration data

Once you have completed your TRISTATION UCN configuration scheme, you must save this program in your database. To do this, follow steps outlined in Table 4-3. Use Figure 4-2 as a visual reference.

Table 4-3 Saving and Downloading TRISTATION UCN Data

Step	Action
1	Once your configuration is complete, call up the FILE MANAGER screen. To do this press the [ALT 0] keys.
2	Press the [F2 SAVE PROGRAM] key to save the configuration you have just completed. It will prompt you for a file name.
3	Enter in a file name for your configuration program and press the [ENTER] key.  You have now saved your program and should see it on your screen.
4	Download the configuration data with the [F10 DOWNLD ALL] function key.

### File Manager screen

Figure 4-2 shows the File Manager screen for the TRISTATION.

Figure 4-2 TRISTATION File Manager Screen

FILE MANAGEMEN	
F1 LOAD PROGRM	F2 SAVE PROGRM
F3 NEW PROGRM	F4 EXIT
F5 DELETE FILE	F6 CHANGE DIR
F7 LIST FILES	F8 LIST OTHER
F9 DOWNLD CHANGE	F2 DOWNLD CONFIG

TRISTATION MSW 2.0.1 (4507, 45)  
 Free disk space: 20.983 Mb  
 Current version of "SOECONFG":1.1

R11 files available in "C:\MSW200

SMMCONF SOECONFG

Help: <ALT> = Menu <A

Program: SOECO

14285

*Continued on next page*

## 4.2 TRISTATION UCN Configuration, Continued

---

### How to tell if the SM is configured

Once configuration is complete, the SMM's 4-character alphanumeric display will show A and the node number configured for the active module, and A and the associated even address number for the backup (hot spare) module.

If the SMM(s) is not yet configured, the alphanumeric display windows on the Safety Manager Modules will both show CFG? The PI cannot be loaded.

---

### ATTENTION

While performing a DOWNLOAD ALL, the TRISTATION displays may report the SMM(s) as missing. This is normal if the download involved a configuration change that forced the SMM(s) to restart, thus making them temporarily blind to the Main Processors. Once an SMM completes restart, it will automatically re-establish a connection with the TRICON Main Processors.

---

## 4.3 Sequence of Events (SOE) Configuration

### Configuring your system for SOE

During each scan of a control program, the TRICON examines selected discrete variables for state changes known as events. SOE block configuration allows you to specify which discrete aliased variables defined in the control program are to be monitored by the TRICON for state changes.

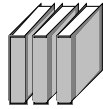

Refer to Triconex's *Sequence of Events User's Manual* for detailed information about SOE functions and capabilities.

### Setting up the control program for SOE

To use SOE, you must configure the TRISTATION to do the following when setting up your control program:

- Define the event variables and their alias numbers in the Dictionary Editor screen [ALT 2].

**ATTENTION** Event variables must be of the DI type.

- Add SOE functions to your ladder logic to start and stop the collection of data into your SOE blocks using the Ladder Editor screen [ALT 1].

**ATTENTION** Special functions are provided for this and can enable either SOE blocks 15, 16 or both. These functions should only be called on the first TRICON scan, using the TRICON "first scan" condition in the ladder logic program.

- Download the control program with the [F10 DOWNLD ALL] function of the File Manager screen [ALT 0].

This subsection will focus on grouping the event variables using the SOE Block Configuration screen. Refer to the Triconex *SOE User's Manual* for other control program manipulation for enabling SOE.

### About SOE block configuration

There are a total of 16 SOE blocks. Blocks 15 and 16 are always External Blocks for use with the Safety Manager Module(s) only. All other discrete variables are defined at the Universal Station. These are the only blocks you will be configuring.

### SOE Block Configuration screen

The SOE Block Configuration screen allows you to organize event variables for your control program as blocks. When you configure an External Block, block size and name are the only items specified. DI points to be collected are configured at the US.

### Alias range limitations

Only alias ranges 2001-4000, 10000-12000, and 12001-14000 are available for DISOE. The PLCADDR parameter of a DI point must be within the above ranges before SOE can be enabled for a given point.

*Continued on next page*

## 4.3 Sequence of Events (SOE) Configuration, Continued

### Using the SOE Block Configuration screen

Use Table 4-4 to guide you through the SOE block configuration procedure and Figure 4-3 as a visual reference.

Table 4-4 SOE Block Configuration Procedure

Step	Action
1	Press the [ALT 4] keys to bring up the SOE Block Configuration screen.
2	Use the [F1 PREV BLOCK] and [F2 NEXT BLOCK] keys to get to block 15 or 16.
3	Press the [F3 CONFIG BLOCK] key. A window for SOE configuration parameters will come up.
4	Use the arrows and [ENTER] key to configure your SOE parameters as desired.  <div style="border: 1px solid black; padding: 5px; display: inline-block;"> <b>ATTENTION</b> Blocks 15 and 16 are used exclusively for the SMM. Buffer size and name will be the only items configured for these blocks. DI points to be collected are configured at the US.         </div>
5	Press the [ESC] key once you have completed your configuration.

### SOE Block Configuration screen

Figure 4-3 shows the SOE Block Configuration screen.

Figure 4-3 TRISTATION SOE Block Configuration Screen

<b>SOE BLOCK CONFIGURAT</b>	Title: SM SOE CON	Buffer: 100 ev
F1 PREV BLOCK	F2 NEXT BLOCK	<b>BLOCK 15/16 - MOD_EXTERNL</b> <b>0 SYMBOLS HAVE</b>
F3 CONFIG BLOCK	F4 CLEAR BLOCK	SELECT-NAME ----- DESCRIPTION -----
F5 SELECT ON/OFF	F6 CLEAR SELECT	<div style="border: 3px double black; padding: 10px; margin: 10px auto; width: 80%;"> <p style="text-align: center; margin: 0;"><b>CONFIGURE SOE BLOCK PARAME</b></p> <p>Title      SM SOE CONFIG</p> <p>Buffer    Size 100 (maximum is 20000 even</p> <p>Type      MOD_EXTERNL</p> </div>
F7 FIND NAME	F8 FIND ALIAS	
F9 VIEW OPTION	F2 PRINT CONFIG	

Help: <ALT> = Menu <A

Program: SOECOM

14286

*Continued on next page*

## 4.3 Sequence of Events (SOE) Configuration, Continued

### **Saving and downloading SOE data**

Once you have completed your SOE configuration scheme, you must save and load this program into your database. To do this, follow the steps outlined in Table 4-5. Refer back to Figure 4-2 as a visual reference.

Table 4-5 Saving and Downloading SOE Configuration Data

<b>Step</b>	<b>Action</b>
<b>1</b>	Once your configuration is complete, call up the FILE MANAGER screen. To do this press the [ALT 0] keys.
<b>2</b>	Press the [F2 SAVE PROGRAM] key to save the configuration you have just completed. It will prompt you for a file name.
<b>3</b>	Enter in a file name for your SOE configuration program and press the [ENTER] key.  You have now saved your program and should see it on your screen.
<b>4</b>	Download the configuration data with the [F10 DOWNLD ALL] function key.

## 4.4 US Configuration

### Introduction

Once the UCN has been configured at the TRISTATION, you will need to use the Universal Station (US) to complete SM system configuration. This section will discuss the following US configurations:

- Universal Control Network (UCN),
- Node-specific (SM device), and
- SMM data points.

### Configuration assumptions

This section covers the SM configuration process at the US. It assumes that you have completed the implementation steps for start-up and have prepared the History Module (HM) and the system for network configuration.

Table 4-6 outlines the start-up process for the TDC 3000<sup>X</sup>. If these procedures have not been done, refer to the LCN bookset - *Implementation Startup & Reconfiguration*, binder TDC 2030-1.

Table 4-6 Start-up and Reconfiguration Procedures

Step	Action	Result
1	Prepare the system for network configuration.	Engineer Personality is in "this US." Current time and date is in "this US." The system start-up floppy is in a secure place.
2	Configure the network.	A site-specific Network Configuration File (NCF), required as input to subsequent procedures, is available.
3	Prepare the History Module.	The History Module can now be used as a source for configuration programs and data.

### UCN configuration

Once you have completed the start-up process for the US, follow the steps outlined in Table 4-7.

Table 4-7 UCN Configuration

Step	Action
1	Press the RESET button.  <b>ATTENTION</b> Reset button is located under black metal panel at top of operator keyboard.
2	Press the LOAD button on operator keyboard. System will state 'Loading in progress'.
3	A prompt will come up "N, 1, 2, 3, 4?", press N for Node and press the [ENTER] key.
4	Another prompt will come up "OPR, UNP, X?", press U for Universal Personality and press the [ENTER] key.

*Continued on next page*

## 4.4 US Configuration, Continued

### First US display

Once you have loaded the Universal Personality, the System Status display will be the first display to come up. Figure 4-4 shows this display.

Figure 4-4 US System Status Display

MAKE SELECTION										02 May 95 11:13:09 3		
SYS VERS: R500					SYSTEM STATUS FROM US13							
NCF VERS: 09Feb95 00:14:19:157												
CABLE A: OK					CABLE B: OK							
US01	US02	US03	US04	US05	US06	US07	US08	US09	US10	US11	US12	US13
OFF	OFF	OFF	OFF	OFF	OFF	OFF	OFF	OFF	OFF	OFF	OFF	OK
US14	US15	US16	US17	US18	US19	US20	NM21	NM22	NM23 UCN 02	NM24 UCN 02	NM25	NM26
OFF	OFF	OFF	OFF	OFF	OFF	OFF	OFF	OFF	OFF	OK	OFF	OFF
NM27	NM28	NM29	NM30	NM31	HG37	HG39	HM43	AM45	AM46	CG 49		
OFF	OFF	OFF	OFF	OFF	OFF	OFF	OK	OFF	OFF	OFF		
LOAD SELECT	LOAD CONFIG	SHOW LOADS	DE- SELECT	NTWK/HWY STATUS	NODE STATUS	STATUS DETAIL	LCN DIAG	TIME/ DATE				
LOAD ISOL	LOAD FAIL	LOAD PWR_ON	SELECT AUX INFO	DUMP NODE	SHUT DOWN	LCN OVERVIEW						

14187

*Continued on next page*

## 4.4 US Configuration, Continued

**Engineering Main Menu display** In order to configure your UCN, you will need to bring up the Engineering Main Menu display. To do this, hold the [CTRL] key on the engineering keyboard and press the [HELP(M)] key. Figure 4-5 shows this display.

Once you have brought this display up, select the NETWORK INTERFACE MODULE target.

Figure 4-5 US Engineering Main Menu Display

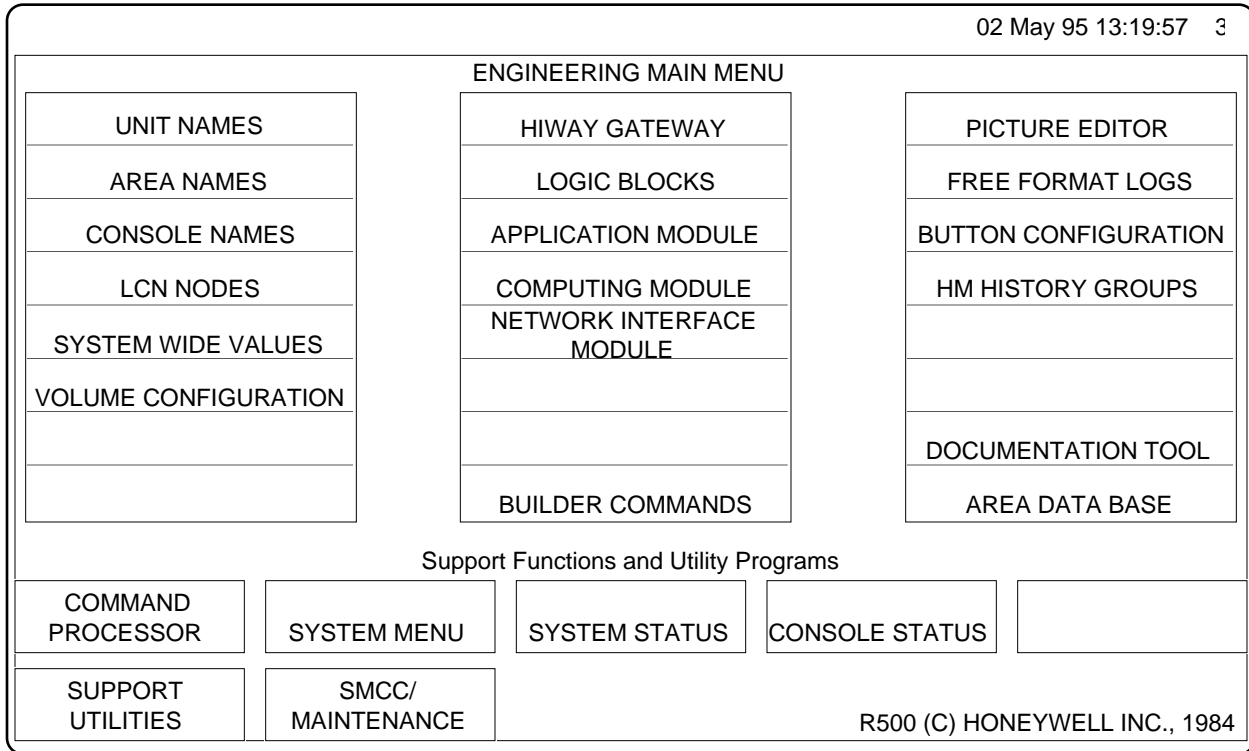

14188

*Continued on next page*

## 4.4 US Configuration, Continued

### NIM Build Type Select Menu display

The NIM Build Type Select Menu display will be the next display to come up. This display is shown in Figure 4-6. Select the UCN NODE CONFIGURATION target to configure the UCN.

Figure 4-6 US NIM Build Type Select Menu

02 May 95 13:22:07 3					
MENU		PAGE 01 OF 01			
NIM BUILD TYPE SELECT MENU					
<div style="border: 1px solid black; padding: 5px; width: fit-content; margin: 10px auto;">UCN NODE CONFIGURATION</div> <div style="border: 1px solid black; padding: 5px; width: fit-content; margin: 10px auto;">NODE SPECIFIC CONFIGURATION</div> <div style="border: 1px solid black; padding: 5px; width: fit-content; margin: 10px auto;">PROCESS POINT BUILDING</div> <div style="border: 1px solid black; padding: 5px; width: fit-content; margin: 10px auto;">LIBRARY CONFIGURATION</div>					
NIM YH_GDF 50.11					
F1=PED	F3=	F5=OVERWRITE	F7=RECON	F9 =WLK BACK	F11=
F2=RECALL DISP	F4=	F6=	F8=PED STATUS	F10=WRITE	F12=LOAD

14189

### UCN Node Configuration display

You should now be in the UCN Node Configuration display. Figure 4-7 shows this display. Do the steps in Table 4-8 to configure the UCN.

Table 4-8 UCN Node Configuration

Step	Action
1	Enter the requested data in the given slots. All configuration information should be taken from the SM Configuration Forms you have filled out.
2	Select the SM for UCN node type and TRICON for the SM platform.
3	Press the [F12 LOAD] key to load your configuration.

**ATTENTION** The node number you select must correspond with the node number you entered into the TRISTATION UCN configuration.

*Continued on next page*

## 4.4 US Configuration, Continued

**UCN Node Configuration display,**  
continued

Note that the network number can be from 1 to 20. The node number can range from 1 to 63, using odd numbers only.

Figure 4-7 US UCN Node Configuration Display

		02 May 95 13:25:17 3	
PED >>>>>> POINT:\$NM02N13		UNIT:SY	PAGE 01 OF 01
UCN NODE CONFIGURATION			
NETWORK NUMBER	(NTWKNUM)	<input type="text" value="02"/>	
NODE NUMBER	(NODENUM)	<input type="text" value="13"/>	
UCN NODE TYPE	(NODETYP)	<input type="text" value="NOTCONFIG"/>	<input type="text" value="NIM"/>
		<input type="text" value="PM"/>	<input type="text" value="APM"/>
		<input type="text" value="HPM"/>	<input type="text" value="LM"/>
		<input checked="" type="text" value="SM"/>	<input type="text" value="PM1"/>
SM PLATFORM	(SMPLTFM)	<input checked="" type="text" value="TRICON"/>	<input type="text" value="FSC"/>
NODE ASSIGNMENT	(NODEASSN)	<input checked="" type="text" value="THISNIM"/>	<input type="text" value="REMOTNIM"/>
DIGITAL COMPOSITE PV STATE TEXT			
MOVING TEXT	(MOVPVTXT)	<input type="text" value="MOVING"/>	
BAD TEXT	(BADPVTXT)	<input type="text" value="BAD"/>	
F1=PED	F3=	F5=OVERWRITE	F7=RECON
F2=RECALL DISP	F4=	F6=	F8=PED STATUS
			F9 =WLK BACK
			F10=WRITE
			F11=
			F12=LOAD

14578

*Continued on next page*

## 4.4 US Configuration, Continued

### Node-specific configuration

To configure the node-specific data, return to the NIM Build Type Select Menu by pressing the [F9 WLK BACK] key. Refer back to Figure 4-6. Select the NODE SPECIFIC CONFIGURATION target. The Node-Specific Configuration display is shown in Figure 4-8.

Enter and select the desired configuration. Press the [F12 LOAD] key.

**ATTENTION** Make sure the network and node numbers entered for this display match those entered in the UCN Configuration display.

There is no need to configure the redundant SM device. All SM-related information will be automatically transferred to the “new” primary SM should there be a failover or switchover to the backup.

Figure 4-8 US Node-Specific Configuration Display

02 May 95 13:29:30 3					
PED >>>>>> POINT:\$NM02B13		UNIT:SY	UNENTERED	PAGE 01 OF 03	
NODE-SPECIFIC CONFIGURATION					
NETWORK NUMBER	(NTWKNUM)	<input type="text" value="02"/>			
NODE NUMBER	(NODENUM)	<input type="text" value="13"/>			
NODE TYPE	(NODETYP)	<input type="text" value="PM"/>	<input type="text" value="APM"/>	<input type="text" value="HPM"/>	
		<input type="text" value="LM"/>	<input checked="" type="text" value="SM"/>	<input type="text" value="PM1"/>	
SM PLATFORM	(SMPLTFM)	<input checked="" type="text" value="TRICON"/>	<input type="text" value="FSC"/>		
*****					
* WARNING: IF THE POINT MIX OR THE SCAN					
* RATE IS CHANGED, THEN THE NODE'S FULL					
* DATA BASE WILL BE SET TO ITS DEFAULT.					
* THE DISPLAY LINES WHICH CAN CAUSE THE					
* DATA BASE TO BE DEFAULTED ARE STARRED					
* AND HAVE AN ASTERISK (*) IN COLUMN 80.					
*****					
F1=PED	F3=	F5=OVERWRITE	F7=RECON	F9 =WLK BACK	F11=
F2=RECALL DISP	F4=	F6=	F8=PED STATUS	F10=WRITE	F12=LOAD

14579

*Continued on next page*

## 4.4 US Configuration, Continued

### Process Point Building display

You must once again return to the NIM Build Type Select Menu to access the SMM data point building displays. To do this, press the [F1 PED] key.

Select the PROCESS POINT BUILDING target, once you have returned to the NIM Build Type Select Menu. Figure 4-9 shows the display which will be brought up.

Figure 4-9 US Process Point Building Display

02 May 95 13:33:40 3					
MENU		PAGE 01 OF 01			
NIM BUILD TYPE SELECT MENU					
NIM PROCESS POINT BUILD TYPE					
	ANALOG INPUT		ANALOG OUTPUT		
	DIGITAL INPUT		DIGITAL OUTPUT		DIGITAL COMPOSITE
	REGULATORY PV		REGULATORY CONTROL		
	LOGIC				
	FLAG		TIMER		NUMERIC
	ARRAY		DEVICE CONTROL		
	PROCESS MODULE				
F1=PED	F3=	F5=OVERWRITE	F7=RECON	F9 =WLK BACK	F11=
F2=RECALL DISP	F4=	F6=	F8=PED STATUS	F10=WRITE	F12=LOAD

14193

*Continued on next page*

## 4.4 US Configuration, Continued

### Building SMM data points

This subsection takes you through the general steps for SMM data point configuration. To build SMM data points, you will need to follow the steps listed in Table 4-9.

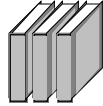

Refer to Appendix A for a page-by-page view of the configuration parameters for a given SMM point type. Also refer to *Section 4—Data Point Detailed Description* in document SM09-500, *Safety Manager Module Control Functions*, for more information.

**ATTENTION** Information on the definition of a specific parameter can be provided to you online by pressing the [HELP] key for the parameter you have selected.

Table 4-9 SMM Data Point Configuration Procedure

Step	Action
1	Once you are in the Process Point Building display, select the SMM point type you wish to configure.
2	Enter and select the desired configuration scheme. Use the [PAGE FWD] button on the operator keyboard to move to the next configuration page as needed. <b>ATTENTION</b> Data entered should be based on the SM Configuration Forms you have filled out.
3	Press the [F12 LOAD] key to load the data in the SM database.
4	Press the [F9 WLK BACK] key to return to the Process Point Building display.
5	Repeat steps for next SMM data point type until all point types are configured.

**ATTENTION** TRICON aliases must be configured before points can be downloaded against given aliases.



# Appendix A – SMM Data Point Configuration Displays

## A.1 Overview

### About this section

This appendix contains sample displays that can be viewed from the Universal Station when configuring SMM data points.

**ATTENTION** The highlighted selections in these displays are for example purposes only. Make your selections based on your process needs.

Topics included in this section are:

Subsection	Topic	See Page
A.1	Overview.....	65
A.2	Analog Input.....	66
A.3	Analog Output.....	68
A.4	Digital Input .....	70
A.5	Digital Output .....	73
A.6	Digital Composites.....	74
A.7	Logic .....	78
A.8	Flag .....	81
A.9	Timer .....	82
A.10	Numeric .....	84

## A.2 Analog Input

Page 1 of 4

		02 May 95 14:35:08 3			
PED >>>>>> POINT:		UNIT:	UNENTERED PAGE 01 OF 04		
NIM-POINT ASSIGNMENT ANALOG INPUT					
TAG NAME	(NAME)	<input type="text"/>			
NODE TYPE	(NODETYP)	<input type="text" value="PM"/>	<input type="text" value="APM"/> <input type="text" value="HPM"/>		
		<input type="text" value="LM"/>	<input checked="" type="text" value="SM"/> <input type="text" value="PM1"/>		
SM PLATFORM	(SMPLTFM)	<input checked="" type="text" value="TRICON"/>	<input type="text" value="FSC"/>		
POINT FORM	(PNTFORM)	<input checked="" type="text" value="FULL"/>	<input type="text" value="COMPONNT"/>		
POINT DESCRIPTOR	(PTDESC)	<input type="text"/>			
E.U. DESCRIPTOR	(EUDESC)	<input type="text"/>			
POINT KEYWORD	(KEYWORD)	<input type="text"/>			
ASSOCIATED DISPLAY	(ASSOCDSP)	<input type="text"/>			
UNIT ID	(UNIT)	<input type="text"/>			
NETWORK NUMBER	(NTWKNUM)	<input type="text"/>			
F1=PED	F3=	F5=OVERWRITE	F7=RECON	F9 =WLK BACK	F11=
F2=RECALL DISP	F4=	F6=	F8=PED STATUS	F10=WRITE	F12=LOAD

14580

Page 2 of 4

		02 May 95 14:36:47 3			
PED >>>>>> POINT:		UNIT:	UNENTERED PAGE 02 OF 04		
NODE NUMBER	(NODENUM)	<input type="text"/>			
MODULE NUMBER	(MODNUM)	<input type="text"/>			
PRIMARY MODULE POINT ID	(PRIMMOD)	<input type="text" value="-----"/>			
F1=PED	F3=	F5=OVERWRITE	F7=RECON	F9 =WLK BACK	F11=
F2=RECALL DISP	F4=	F6=	F8=PED STATUS	F10=WRITE	F12=LOAD

14581

## A.2 Analog Input, Continued

Page 3 of 4

		02 May 95 14:40:00 3			
PED >>>>>> POINT:		UNIT:	UNENTERED PAGE 03 OF 04		
NIM-PV CONFIGURATION ANALOG INPUT					
PV RANGE HIGH	(PVEUHI)	<input type="text" value="100.0"/>			
PV RANGE LOW	(PVEULO)	<input type="text" value="0.0"/>			
PV DECIMAL FORMAT	(PVFORMAT)	<input type="text" value="D0"/>	<input checked="" type="radio"/> D1	<input type="text" value="D2"/>	<input type="text" value="D3"/>
PV RANGE EXTENSION HIGH	(PVEXEUHI)	<input type="text" value="102.9"/>			
PV RANGE EXTENSION LOW	(PVEXEULO)	<input type="text" value="-2.9"/>			
PV CLAMPING OPTION	(PVCLAMP)	<input type="text" value="CLAMP"/>	<input checked="" type="radio"/> NOCLAMP		
PV SOURCE OPTION	(PVSRCOPT)	<input checked="" type="radio"/> ONLYAUTO <input type="text" value="ALL"/>			
PV FILTER LAG TIME	(TF)	<input type="text" value="0.0"/>			
PV TARGET VALUE	(PVTV)	<input type="text" value="-----"/>			
OVERVIEW VALUE	(OVERVAL)	<input type="text" value="25"/>			
F1=PED      F3=      F5=OVERWRITE    F7=RECON      F9 =WLK BACK    F11= F2=RECALL DISP   F4=      F6=      F8=PED STATUS    F10=WRITE      F12=LOAD					

14210

Page 4 of 4

		02 May 95 14:50:24 3			
PED >>>>>> POINT:		UNIT:	UNENTERED PAGE 04 OF 04		
NIM-ALARMING DISPLAY ANALOG INPUT					
PV ALARM DEADBAND IN %	(PVALDB)	<input type="text" value="HALF"/>	<input checked="" type="radio"/> ONE	<input type="text" value="TWO"/>	<input type="text" value="THREE"/>
		<input type="text" value="FOUR"/>	<input type="text" value="FIVE"/>	<input type="text" value="EU"/>	
PV HIGH TRIP POINT	(PVHITP)	<input type="text" value="----"/>			
PV LOW TRIP POINT	(PVLOTP)	<input type="text" value="----"/>			
POSITIVE PV ROC TRIP POINT	(PVROCTP)	<input type="text" value="----"/>			
NEGATIVE PV ROC TRIP POINT	(PVROCNTP)	<input type="text" value="----"/>			
BAD PV ALARM PRIORITY	(BADPVPR)	<input type="text" value="NOACTION"/>	<input type="text" value="JOURNAL"/>	<input checked="" type="radio"/> LOW	<input type="text" value="HIGH"/>
		<input type="text" value="EMERGENCY"/>	<input type="text" value="PRINTER"/>	<input type="text" value="JNLPRINT"/>	
ALARM ENABLE STATE	(ALENBST)	<input checked="" type="radio"/> ENABLE <input type="text" value="DISABLE"/> <input type="text" value="INHIBIT"/>			
F1=PED      F3=      F5=OVERWRITE    F7=RECON      F9 =WLK BACK    F11= F2=RECALL DISP   F4=      F6=      F8=PED STATUS    F10=WRITE      F12=LOAD					

14211

# A.3 Analog Output

Page 1 of 4

		02 May 95 14:52:21 3	
PED >>>>>> POINT:		UNIT:	UNENTERED PAGE 01 OF 04
NIM-POINT ASSIGNMENT ANALOG OUTPUT			
TAG NAME	(NAME)	<input type="text"/>	
NODE TYPE	(NODETYP)	<input type="text" value="PM"/>	<input type="text" value="APM"/>
		<input type="text" value="LM"/>	<input checked="" type="text" value="SM"/>
SM PLATFORM	(SMPLTFM)	<input checked="" type="text" value="TRICON"/>	<input type="text" value="FSC"/>
		<input checked="" type="text" value="FULL"/>	<input type="text" value="COMPONNT"/>
POINT FORM	(PNTFORM)		
POINT DESCRIPTOR	(PTDESC)	<input type="text"/>	
E.U. DESCRIPTOR	(EUDESC)	<input type="text"/>	
POINT KEYWORD	(KEYWORD)	<input type="text"/>	
ASSOCIATED DISPLAY	(ASSOCDSP)	<input type="text"/>	
UNIT ID	(UNIT)	<input type="text"/>	
NETWORK NUMBER	(NTWKNUM)	<input type="text"/>	
F1=PED		F3=	F5=OVERWRITE
F2=RECALL DISP		F4=	F6=
		F7=RECON	F9 =WLK BACK
		F8=PED STATUS	F11=
		F10=WRITE	F12=LOAD

14582

Page 2 of 4

		02 May 95 14:53:58 3	
PED >>>>>> POINT:		UNIT:	UNENTERED PAGE 02 OF 04
NODE NUMBER	(NODENUM)	<input type="text"/>	
SLOT NUMBER	(SLOTNUM)	<input type="text"/>	
PRIMARY MODULE POINT ID	(PRIMMOD)	<input type="text" value="-----"/>	
F1=PED		F3=	F5=OVERWRITE
F2=RECALL DISP		F4=	F6=
		F7=RECON	F9 =WLK BACK
		F8=PED STATUS	F11=
		F10=WRITE	F12=LOAD

14583

# A.3 Analog Output, Continued

Page 3 of 4

PED >>>>>> POINT:		UNIT:	UNENTERED	PAGE 03 OF 04	
02 May 95 14:55:32 3					
NIM-OPERATING CONFIGURATION ANALOG OUTPUT					
OUTPUT DIRECTION	(OPTDIR)	<input checked="" type="checkbox"/> DIRECT	<input type="checkbox"/> REVERSE		
OUTPUT CHARACTERIZATION	(OPCHAR)	<input checked="" type="checkbox"/> OFF	<input type="checkbox"/> ON		
F1=PED	F3=	F5=OVERWRITE	F7=RECON	F9 =WLK BACK	F11=
F2=RECALL DISP	F4=	F6=	F8=PED STATUS	F10=WRITE	F12=LOAD

14214

Page 4 of 4

PED >>>>>> POINT:		UNIT:	UNENTERED	PAGE 04 OF 04	
02 May 95 14:57:16 3					
NIM-OPERATING CONFIGURATION ANALOG OUTPUT					
OUTPUT RAW HIGH LIMIT	(OPFINHI)	<input type="text" value="4095.0"/>			
OUTPUT RAW LOW LIMIT	(OPFINLO)	<input type="text" value="0.0"/>			
OUTPUT DIRECTION	(OPTDIR)	<input checked="" type="checkbox"/> DIRECT	<input type="checkbox"/> REVERSE		
F1=PED	F3=	F5=OVERWRITE	F7=RECON	F9 =WLK BACK	F11=
F2=RECALL DISP	F4=	F6=	F8=PED STATUS	F10=WRITE	F12=LOAD

14215

# A.4 Digital Input

Page 1 of 4

02 May 95 13:35:40 3	
PED >>>>>> POINT:	UNIT: UNENTERED PAGE 01 OF 04
NIM-POINT ASSIGNMENT DIGITAL INPUT	
TAG NAME (NAME)	<input type="text"/>
NODE TYPE (NODETYP)	<input type="text" value="PM"/> <input type="text" value="APM"/> <input type="text" value="HPM"/>
	<input type="text" value="LM"/> <input checked="" type="text" value="SM"/> <input type="text" value="PM1"/>
SM PLATFORM (SMPLTFM)	<input checked="" type="text" value="TRICON"/> <input type="text" value="FSC"/>
POINT FORM (PNTFORM)	<input checked="" type="text" value="FULL"/> <input type="text" value="COMPONNT"/>
POINT DESCRIPTOR (PTDESC)	<input type="text"/>
E.U. DESCRIPTOR (EUDESC)	<input type="text"/>
POINT KEYWORD (KEYWORD)	<input type="text"/>
ASSOCIATED DISPLAY (ASSOCDSP)	<input type="text"/>
UNIT ID (UNIT)	<input type="text"/>
NETWORK NUMBER (NTWKNUM)	<input type="text"/>
F1=PED      F3=      F5=OVERWRITE      F7=RECON      F9 =WLK BACK      F11= F2=RECALL DISP      F4=      F6=      F8=PED STATUS      F10=WRITE      F12=LOAD	

14584

Page 2 of 4

02 May 95 13:50:40 3	
PED >>>>>> POINT:	UNIT: UNENTERED PAGE 02 OF 04
NODE NUMBER (NODENUM)	<input type="text"/>
SLOT NUMBER (SLOTNUM)	<input type="text"/>
PRIMARY MODULE POINT ID (PRIMMOD)	<input type="text" value="-----"/>
DIGITAL INPUT TYPE (DITYPE)	<input checked="" type="text" value="STATUS"/> <input type="text" value="LATCHED"/> <input type="text" value="ACCUM"/>
F1=PED      F3=      F5=OVERWRITE      F7=RECON      F9 =WLK BACK      F11= F2=RECALL DISP      F4=      F6=      F8=PED STATUS      F10=WRITE      F12=LOAD	

14585

# A.4 Digital Input, Continued

Page 3 of 4

		02 May 95 13:52:45 3	
PED >>>>>> POINT:		UNIT:	UNENTERED PAGE 03 OF 04
NIM- OPERATING CONFIGURATION			
DIGITAL INPUT			
STATE 1 DESCRIPTOR	(STATETXT(1))	<input type="text" value="ON"/>	
STATE 0 DESCRIPTOR	(STATETXT(0))	<input type="text" value="OFF"/>	
STATE 1 BOX COLOR	(BOXCLR(1))	<input type="text" value="RED"/>	<input checked="" type="text" value="GREEN"/>
		<input type="text" value="WHITE"/>	<input type="text" value="BLACK"/>
		<input type="text" value="CYAN"/>	<input type="text" value="YELLOW"/>
		<input type="text" value="BLUE"/>	<input type="text" value="MAGENTA"/>
STATE 0 BOX COLOR	(BOXCLR(0))	<input type="text" value="RED"/>	<input type="text" value="GREEN"/>
		<input type="text" value="WHITE"/>	<input type="text" value="BLACK"/>
		<input type="text" value="CYAN"/>	<input checked="" type="text" value="YELLOW"/>
		<input type="text" value="BLUE"/>	<input type="text" value="MAGENTA"/>
INPUT DIRECTION	(INPTDIR)	<input checked="" type="text" value="DIRECT"/>	<input type="text" value="REVERSE"/>
PV SOURCE OPTION	(PVSRCOPT)	<input checked="" type="text" value="ONLYAUTO"/>	<input type="text" value="ALL"/>
F1=PED		F3=	F5=OVERWRITE
F2=RECALL DISP		F4=	F6=
		F7=RECON	F9 =WLK BACK
		F8=PED STATUS	F10=WRITE
			F11=
			F12=LOAD

14196

Continued on next page

# A.4 Digital Input, Continued

Page 4 of 4

		02 May 95 13:54:44 3	
PED >>>>>> POINT:		UNIT:	UNENTERED PAGE 04 OF 04
NIM- OPERATING CONFIGURATION DIGITAL INPUT			
ALARMING OPTION	(ALMOPT)	<input checked="" type="checkbox"/> NONE	<input type="checkbox"/> OFFNORML <input type="checkbox"/> CHNGOFST
EVENT REPORT OPTION	(EVTOPT)	<input type="checkbox"/> NONE <input type="checkbox"/> EIP	<input checked="" type="checkbox"/> SOE <input type="checkbox"/> EIP_SOE
F1=PED F3= F5=OVERWRITE F7=RECON F9 =WLK BACK F11= F2=RECALL DISP F4= F6= F8=PED STATUS F10=WRITE F12=LOAD			

14197

**ATTENTION** SOE must be chosen for points to be collected by TRICON DISOE. This is how DISOE points are configured. This differs from other TRICON SOE blocks (1-14).

The SOE block number is transparent at this point and data points fall into an SOE block based on which block number (15 or 16) was configured for this SM's UCN node address.

# A.5 Digital Output

Page 1 of 2

02 May 95 13:56:16 3	
PED >>>>>> POINT:	UNIT: UNENTERED PAGE 01 OF 02
NIM-POINT ASSIGNMENT DIGITAL OUTPUT	
TAG NAME (NAME)	<input type="text"/>
NODE TYPE (NODETYP)	<input type="text" value="PM"/> <input type="text" value="APM"/> <input type="text" value="HPM"/>
	<input type="text" value="LM"/> <input checked="" type="text" value="SM"/> <input type="text" value="PM1"/>
SM PLATFORM (SMPLTFM)	<input checked="" type="text" value="TRICON"/> <input type="text" value="FSC"/>
POINT FORM (PNTFORM)	<input checked="" type="text" value="FULL"/> <input type="text" value="COMPONNT"/>
POINT DESCRIPTOR (PTDESC)	<input type="text"/>
E.U. DESCRIPTOR (EUDESC)	<input type="text"/>
POINT KEYWORD (KEYWORD)	<input type="text"/>
ASSOCIATED DISPLAY (ASSOCDSP)	<input type="text"/>
UNIT ID (UNIT)	<input type="text"/>
NETWORK NUMBER (NTWKNUM)	<input type="text"/>
F1=PED      F3=      F5=OVERWRITE      F7=RECON      F9 =WLK BACK      F11= F2=RECALL DISP      F4=      F6=      F8=PED STATUS      F10=WRITE      F12=LOAD	

14586

Page 2 of 2

02 May 95 13:58:27 3	
PED >>>>>> POINT:	UNIT: UNENTERED PAGE 02 OF 02
NODE NUMBER (NODENUM)	<input type="text"/>
SLOT NUMBER (SLOTNUM)	<input type="text"/>
DIGITAL OUTPUT TYPE (DOTYPE)	<input checked="" type="text" value="STATUS"/> <input type="text" value="PWM"/>
F1=PED      F3=      F5=OVERWRITE      F7=RECON      F9 =WLK BACK      F11= F2=RECALL DISP      F4=      F6=      F8=PED STATUS      F10=WRITE      F12=LOAD	

14587

# A.6 Digital Composite

Page 1 of 8

02 May 95 14:05:17 3	
PED >>>>>> POINT:	UNIT: UNENTERED
PAGE 01 OF 08	
NIM-POINT ASSIGNMENT DIGITAL COMPOSITE	
TAG NAME (NAME)	<input type="text"/>
NODE TYPE (NODETYP)	<input type="text" value="PM"/> <input type="text" value="APM"/> <input type="text" value="HPM"/>
	<input type="text" value="LM"/> <input checked="" type="text" value="SM"/> <input type="text" value="PM1"/>
SM PLATFORM (SMPLTFM)	<input checked="" type="text" value="TRICON"/> <input type="text" value="FSC"/>
POINT FORM (PNTFORM)	<input checked="" type="text" value="FULL"/> <input type="text" value="COMPONNT"/>
POINT DESCRIPTOR (PTDESC)	<input type="text"/>
E.U. DESCRIPTOR (EUDESC)	<input type="text"/>
POINT KEYWORD (KEYWORD)	<input type="text"/>
ASSOCIATED DISPLAY (ASSOCDSP)	<input type="text"/>
UNIT ID (UNIT)	<input type="text"/>
NETWORK NUMBER (NTWKNUM)	<input type="text"/>
F1=PED      F3=      F5=OVERWRITE      F7=RECON      F9 =WLK BACK      F11= F2=RECALL DISP      F4=      F6=      F8=PED STATUS      F10=WRITE      F12=LOAD	

14588

Page 2 of 8

02 May 95 14:09:06 3	
PED >>>>>> POINT:	UNIT: UNENTERED
PAGE 02 OF 08	
NODE NUMBER (NODENUM)	<input type="text"/>
SLOT NUMBER (SLOTNUM)	<input type="text"/>
PRIMARY MODULE POINT ID (PRIMMOD)	<input type="text" value="-----"/>
NUMBER OF STATES (NOSTATES)	<input checked="" type="text" value="2"/> <input type="text" value="3"/>
NUMBER OF INPUTS (NODINPTS)	<input type="text" value="0"/> <input checked="" type="text" value="1"/> <input type="text" value="2"/>
NUMBER OF OUTPUTS (NODOPTS)	<input type="text" value="0"/> <input checked="" type="text" value="1"/> <input type="text" value="2"/> <input type="text" value="3"/>
F1=PED      F3=      F5=OVERWRITE      F7=RECON      F9 =WLK BACK      F11= F2=RECALL DISP      F4=      F6=      F8=PED STATUS      F10=WRITE      F12=LOAD	

14589

# A.6 Digital Composite, Continued

Page 3 of 8

02 May 95 14:13:44 3													
PED >>>>>> POINT:	UNIT: UNENTERED PAGE 03 OF 08												
NIM- STATE CONFIGURATION DIGITAL COMPOSITE													
STATE 1 DESCRIPTOR	(STATETXT(1)) <input type="text" value="ON"/>												
STATE 0 DESCRIPTOR	(STATETXT(0)) <input type="text" value="OFF"/>												
STATE 1 BOX COLOR	(BOXCLR(1)) <input type="text" value="RED"/> <input checked="" type="text" value="GREEN"/> <input type="text" value="WHITE"/> <input type="text" value="BLACK"/> <input type="text" value="CYAN"/> <input type="text" value="YELLOW"/> <input type="text" value="BLUE"/> <input type="text" value="MAGENTA"/>												
STATE 0 BOX COLOR	(BOXCLR(0)) <input type="text" value="RED"/> <input type="text" value="GREEN"/> <input type="text" value="WHITE"/> <input type="text" value="BLACK"/> <input type="text" value="CYAN"/> <input checked="" type="text" value="YELLOW"/> <input type="text" value="BLUE"/> <input type="text" value="MAGENTA"/>												
MOMENTARY STATES	(MOMSTATE) <input checked="" type="text" value="NONE"/> <input type="text" value="MOM_0"/> <input type="text" value="MOM_1"/>												
LOGIC SOURCE	(LOGICSRC) <input type="text" value="-----"/>												
<table style="width: 100%; border: none;"> <tr> <td style="width: 25%;">F1=PED</td> <td style="width: 25%;">F3=</td> <td style="width: 25%;">F5=OVERWRITE</td> <td style="width: 25%;">F7=RECON</td> <td style="width: 25%;">F9 =WLK BACK</td> <td style="width: 25%;">F11=</td> </tr> <tr> <td>F2=RECALL DISP</td> <td>F4=</td> <td>F6=</td> <td>F8=PED STATUS</td> <td>F10=WRITE</td> <td>F12=LOAD</td> </tr> </table>		F1=PED	F3=	F5=OVERWRITE	F7=RECON	F9 =WLK BACK	F11=	F2=RECALL DISP	F4=	F6=	F8=PED STATUS	F10=WRITE	F12=LOAD
F1=PED	F3=	F5=OVERWRITE	F7=RECON	F9 =WLK BACK	F11=								
F2=RECALL DISP	F4=	F6=	F8=PED STATUS	F10=WRITE	F12=LOAD								

14202

Page 4 of 8

02 May 95 14:19:21 3													
PED >>>>>> POINT:	UNIT: UNENTERED PAGE 04 OF 08												
NIM- PV/INPUT CONFIGURATION DIGITAL COMPOSITE													
INPUT CONNECTIONS -----													
INPUT	SOURCE POINT.PARAMETER DISRC(N)	DESTINATION											
1	<input style="width: 100%;" type="text"/>	D1											
INPUT STATE CONFIGURATION -----													
D1=ON	(D1_1) <input checked="" type="text" value="PVSTATE1"/> <input type="text" value="PVSTATE0"/>												
PV SOURCE OPTION	(PVSRCOPT) <input checked="" type="text" value="ONLYAUTO"/> <input type="text" value="ALL"/>												
<table style="width: 100%; border: none;"> <tr> <td style="width: 25%;">F1=PED</td> <td style="width: 25%;">F3=</td> <td style="width: 25%;">F5=OVERWRITE</td> <td style="width: 25%;">F7=RECON</td> <td style="width: 25%;">F9 =WLK BACK</td> <td style="width: 25%;">F11=</td> </tr> <tr> <td>F2=RECALL DISP</td> <td>F4=</td> <td>F6=</td> <td>F8=PED STATUS</td> <td>F10=WRITE</td> <td>F12=LOAD</td> </tr> </table>		F1=PED	F3=	F5=OVERWRITE	F7=RECON	F9 =WLK BACK	F11=	F2=RECALL DISP	F4=	F6=	F8=PED STATUS	F10=WRITE	F12=LOAD
F1=PED	F3=	F5=OVERWRITE	F7=RECON	F9 =WLK BACK	F11=								
F2=RECALL DISP	F4=	F6=	F8=PED STATUS	F10=WRITE	F12=LOAD								

14203



# A.6 Digital Composite, Continued

Page 7 of 8

02 May 95 14:27:56 3	
PED >>>>>> POINT:	UNIT: UNENTERED PAGE 07 OF 08
NIM-MODE CONFIGURATION DIGITAL COMPOSITE	
NORMAL MODE ATTRIBUTE (NMODATTR)	<input checked="" type="radio"/> NONE <input type="radio"/> OPERATOR <input type="radio"/> PROGRAM
MODE PERMISSIVE (MODEPERM)	<input checked="" type="radio"/> PERMIT <input type="radio"/> NOTPERM
INTERLOCK BYPASS OPTION (OROPT)	<input checked="" type="radio"/> OFF <input type="radio"/> ON
F1=PED      F3=      F5=OVERWRITE      F7=RECON      F9 =WLK BACK      F11= F2=RECALL DISP      F4=      F6=      F8=PED STATUS      F10=WRITE      F12=LOAD	

14206

Page 8 of 8

02 May 95 14:33:23 3	
PED >>>>>> POINT:	UNIT: UNENTERED PAGE 08 OF 08
NIM- ALARMING DISPLAY DIGITAL COMPOSITE	
ALARMING OPTION (ALMOPT)	<input checked="" type="radio"/> NONE <input type="radio"/> CMDDIS <input type="radio"/> OFFNORML
BAD PV ALARM PRIORITY (BADPVPR)	<input type="radio"/> NOACTION <input type="radio"/> JOURNAL <input checked="" type="radio"/> LOW <input type="radio"/> HIGH
	<input type="radio"/> EMERGENCY <input type="radio"/> PRINTER <input type="radio"/> JNLPRINT
BAD CONTROL ALARM PRIORITY (BADCTLPR)	<input type="radio"/> NOACTION <input type="radio"/> JOURNAL <input checked="" type="radio"/> LOW <input type="radio"/> HIGH
	<input type="radio"/> EMERGENCY <input type="radio"/> PRINTER <input type="radio"/> JNLPRINT
EVENT REPORT OPTION (EVTOPT)	<input type="radio"/> NONE <input checked="" type="radio"/> EIP
EIP POINT ID (EIPCODE)	-----
F1=PED      F3=      F5=OVERWRITE      F7=RECON      F9 =WLK BACK      F11= F2=RECALL DISP      F4=      F6=      F8=PED STATUS      F10=WRITE      F12=LOAD	

14207

# A.7 Logic

Page 1 of 5

		02 May 95 15:02:52 3	
PED >>>>>> POINT:		UNIT:	UNENTERED PAGE 01 OF 05
NIM-POINT ASSIGNMENT LOGIC			
TAG NAME	(NAME)	<input type="text"/>	
NODE TYPE	(NODETYP)	<input type="text" value="PM"/>	<input type="text" value="APM"/>
		<input type="text" value="LM"/>	<input checked="" type="text" value="SM"/>
SM PLATFORM	(SMPLTFM)	<input checked="" type="text" value="TRICON"/>	<input type="text" value="FSC"/>
POINT FORM	(PNTFORM)	<input checked="" type="text" value="FULL"/>	<input type="text" value="COMPONNT"/>
POINT DESCRIPTOR	(PTDESC)	<input type="text"/>	
ASSOCIATED DISPLAY	(ASSOCDSP)	<input type="text"/>	
UNIT ID	(UNIT)	<input type="text"/>	
NETWORK NUMBER	(NTWKNUM)	<input type="text"/>	
NODE NUMBER	(NODENUM)	<input type="text"/>	
SLOT NUMBER	(SLOTNUM)	<input type="text"/>	
F1=PED		F3=	F5=OVERWRITE
F2=RECALL DISP		F4=	F6=
		F7=RECON	F9 =WLK BACK
		F8=PED STATUS	F11=
		F10=WRITE	F12=LOAD

14590

Page 2 of 5

		02 May 95 15:07:12 3	
PED >>>>>> POINT:		UNIT:	UNENTERED PAGE 02 OF 05
PRIMARY MODULE POINT ID	(PRIMMOD)	<input type="text" value="-----"/>	
LOGIC MIX	(LOGMIX)	<input checked="" type="text" value="12_0_12"/>	
NIM-INPUT CONNECTIONS LOGIC			
INPUT #1 CONNECTION	(LISRC(1))	<input type="text" value="-----"/>	
INPUT #2 CONNECTION	(LISRC(2))	<input type="text" value="-----"/>	
INPUT #3 CONNECTION	(LISRC(3))	<input type="text" value="-----"/>	
INPUT #4 CONNECTION	(LISRC(4))	<input type="text" value="-----"/>	
INPUT #5 CONNECTION	(LISRC(5))	<input type="text" value="-----"/>	
INPUT #6 CONNECTION	(LISRC(6))	<input type="text" value="-----"/>	
INPUT #7 CONNECTION	(LISRC(7))	<input type="text" value="-----"/>	
INPUT #8 CONNECTION	(LISRC(8))	<input type="text" value="-----"/>	
INPUT #9 CONNECTION	(LISRC(9))	<input type="text" value="-----"/>	
F1=PED		F3=	F5=OVERWRITE
F2=RECALL DISP		F4=	F6=
		F7=RECON	F9 =WLK BACK
		F8=PED STATUS	F11=
		F10=WRITE	F12=LOAD

14591

# A.7 Logic, Continued

Page 3 of 5

02 May 95 15:11:00 3	
PED >>>>>> POINT:	UNIT: UNENTERED PAGE 03 OF 05
INPUT #10 CONNECTION (LISRC(10))	<input type="text" value="-----"/>
INPUT #11 CONNECTION (LISRC(11))	<input type="text" value="-----"/>
INPUT #12 CONNECTION (LISRC(12))	<input type="text" value="-----"/>
LOGIC INPUT FAILURE HANDLING OPTION (LIBADOPT)	<input type="checkbox"/> OFF <input type="checkbox"/> ON <input checked="" type="checkbox"/> HOLD
LOGIC FLAGS AND NUMERIC – INITIAL VALUES	
NUMERIC 1 (NN(1)) <input type="text" value="----"/>	FLAG 7 (FL(7)) <input checked="" type="checkbox"/> OFF <input type="checkbox"/> ON
NUMERIC 2 (NN(2)) <input type="text" value="----"/>	FLAG 8 (FL(8)) <input checked="" type="checkbox"/> OFF <input type="checkbox"/> ON
NUMERIC 3 (NN(3)) <input type="text" value="----"/>	FLAG 9 (FL(9)) <input checked="" type="checkbox"/> OFF <input type="checkbox"/> ON
NUMERIC 4 (NN(4)) <input type="text" value="----"/>	FLAG 10 (FL(10)) <input checked="" type="checkbox"/> OFF <input type="checkbox"/> ON
	FLAG 11 (FL(11)) <input checked="" type="checkbox"/> OFF <input type="checkbox"/> ON
	FLAG 12 (FL(12)) <input checked="" type="checkbox"/> OFF <input type="checkbox"/> ON
F1=PED      F3=      F5=OVERWRITE    F7=RECON      F9 =WLK BACK    F11= F2=RECALL DISP    F4=      F6=      F8=PED STATUS    F10=WRITE      F12=LOAD	

14592

Page 4 of 5

02 May 95 15:14:10 3			
PED >>>>>> POINT:	UNIT: UNENTERED PAGE 04 OF 05		
NIM-LOGIC OUTPUT CONNECTIONS			
LOGIC			
LOGIC	OUTPUT SOURCE LOSRC(N)	DESTINATION POINT_ID.PARAMETER LODSTN(N)	ENABLE LOENBL(N)
1	<input type="text" value="FL1"/>	<input type="text" value="-----"/>	<input type="text" value="FL1"/>
2	<input type="text" value="FL1"/>	<input type="text" value="-----"/>	<input type="text" value="FL1"/>
3	<input type="text" value="FL1"/>	<input type="text" value="-----"/>	<input type="text" value="FL1"/>
4	<input type="text" value="FL1"/>	<input type="text" value="-----"/>	<input type="text" value="FL1"/>
F1=PED      F3=      F5=OVERWRITE    F7=RECON      F9 =WLK BACK    F11= F2=RECALL DISP    F4=      F6=      F8=PED STATUS    F10=WRITE      F12=LOAD			

14219

# A.7 Logic, Continued

Page 5 of 5

PED >>>>>> POINT:		UNIT:	UNENTERED	PAGE 05 OF 05	
NIM-LOGIC DESCRIPTORS LOGIC					
NUMBER OF DESCRIPTORS	(NODESC)	<input type="text" value="0"/>			
F1=PED	F3=	F5=OVERWRITE	F7=RECON	F9 =WLK BACK	F11=
F2=RECALL DISP	F4=	F6=	F8=PED STATUS	F10=WRITE	F12=LOAD

14220

# A.8 Flag

Page 1 of 2

02 May 95 15:19:08 3	
PED >>>>>> POINT:	UNIT: UNENTERED PAGE 01 OF 02
NIM-POINT ASSIGNMENT FLAG	
TAG NAME (NAME)	<input type="text"/>
NODE TYPE (NODETYP)	<input type="text" value="PM"/> <input type="text" value="APM"/> <input type="text" value="HPM"/>
	<input type="text" value="LM"/> <input checked="" type="text" value="SM"/> <input type="text" value="PM1"/>
SM PLATFORM (SMPLTFM)	<input checked="" type="text" value="TRICON"/> <input type="text" value="FSC"/>
POINT FORM (PNTFORM)	<input checked="" type="text" value="FULL"/> <input type="text" value="COMPONNT"/>
POINT DESCRIPTOR (PTDESC)	<input type="text"/>
E.U. DESCRIPTOR (EUDESC)	<input type="text"/>
POINT KEYWORD (KEYWORD)	<input type="text"/>
ASSOCIATED DISPLAY (ASSOCDSP)	<input type="text"/>
UNIT ID (UNIT)	<input type="text"/>
NETWORK NUMBER (NTWKNUM)	<input type="text"/>
F1=PED      F3=      F5=OVERWRITE      F7=RECON      F9 =WLK BACK      F11= F2=RECALL DISP      F4=      F6=      F8=PED STATUS      F10=WRITE      F12=LOAD	

14593

Page 2 of 2

02 May 95 15:20:41 3	
PED >>>>>> POINT:	UNIT: UNENTERED PAGE 02 OF 02
NODE NUMBER (NODENUM)	<input type="text"/>
SLOT NUMBER (SLOTNUM)	<input type="text"/>
PRIMARY MODULE POINT ID (PRIMMOD)	<input type="text" value="-----"/>
F1=PED      F3=      F5=OVERWRITE      F7=RECON      F9 =WLK BACK      F11= F2=RECALL DISP      F4=      F6=      F8=PED STATUS      F10=WRITE      F12=LOAD	

14594

# A.9 Timer

Page 1 of 3

		02 May 95 15:24:40 3	
PED >>>>>> POINT:		UNIT:	UNENTERED PAGE 01 OF 03
NIM-POINT ASSIGNMENT TIMER			
TAG NAME	(NAME)	<input type="text"/>	
NODE TYPE	(NODETYP)	PM	APM
		LM	SM
SM PLATFORM	(SMPLTFM)	TRICON	FSC
		FULL	COMPONNT
POINT FORM	(PNTFORM)	<input type="text"/>	
POINT DESCRIPTOR	(PTDESC)	<input type="text"/>	
E.U. DESCRIPTOR	(EUDESC)	<input type="text"/>	
POINT KEYWORD	(KEYWORD)	<input type="text"/>	
ASSOCIATED DISPLAY	(ASSOCDSP)	<input type="text"/>	
UNIT ID	(UNIT)	<input type="text"/>	
NETWORK NUMBER	(NTWKNUM)	<input type="text"/>	
F1=PED		F3=	F5=OVERWRITE
F2=RECALL DISP		F4=	F6=
		F7=RECON	F9 =WLK BACK
		F8=PED STATUS	F11=
		F10=WRITE	F12=LOAD

14595

Page 2 of 3

		02 May 95 15:26:35 3	
PED >>>>>> POINT:		UNIT:	UNENTERED PAGE 02 OF 03
NODE NUMBER	(NODENUM)	<input type="text"/>	
SLOT NUMBER	(SLOTNUM)	<input type="text"/>	
PRIMARY MODULE POINT ID	(PRIMMOD)	<input type="text" value="-----"/>	
F1=PED		F3=	F5=OVERWRITE
F2=RECALL DISP		F4=	F6=
		F7=RECON	F9 =WLK BACK
		F8=PED STATUS	F11=
		F10=WRITE	F12=LOAD

14596

# A.9 Timer, Continued

Page 3 of 3

PED >>>>>> POINT:		UNIT:	UNENTERED	PAGE 03 OF 03	
02 May 95 15:28:07 3					
NIM-OPERATING CONFIGURATION					
TIMER					
TIMER BASE PERIOD	(TIMEBASE)	<input checked="" type="checkbox"/> SECONDS	<input type="checkbox"/> MINUTES		
SET TIME	(SP)	<input type="text" value="0"/>			
F1=PED	F3=	F5=OVERWRITE	F7=RECON	F9 =WLK BACK	F11=
F2=RECALL DISP	F4=	F6=	F8=PED STATUS	F10=WRITE	F12=LOAD

14225

# A.10 Numeric

Page 1 of 3

02 May 95 15:31:30 3	
PED >>>>>> POINT:	UNIT: UNENTERED
PAGE 01 OF 03	
NIM-POINT ASSIGNMENT NUMERIC	
TAG NAME	(NAME) <input type="text"/>
NODE TYPE	(NODETYP) <input type="text" value="PM"/> <input type="text" value="APM"/> <input type="text" value="HPM"/>
	<input type="text" value="LM"/> <input checked="" type="text" value="SM"/> <input type="text" value="PM1"/>
SM PLATFORM	(SMPLTFM) <input checked="" type="text" value="TRICON"/> <input type="text" value="FSC"/>
POINT FORM	(PNTFORM) <input checked="" type="text" value="FULL"/> <input type="text" value="COMPONNT"/>
POINT DESCRIPTOR	(PTDESC) <input type="text"/>
E.U. DESCRIPTOR	(EUDESC) <input type="text"/>
POINT KEYWORD	(KEYWORD) <input type="text"/>
ASSOCIATED DISPLAY	(ASSOCDSP) <input type="text"/>
UNIT ID	(UNIT) <input type="text"/>
NETWORK NUMBER	(NTWKNUM) <input type="text"/>
F1=PED      F3=      F5=OVERWRITE      F7=RECON      F9 =WLK BACK      F11= F2=RECALL DISP      F4=      F6=      F8=PED STATUS      F10=WRITE      F12=LOAD	

14597

Page 2 of 3

02 May 95 15:35:12 3	
PED >>>>>> POINT:	UNIT: UNENTERED
PAGE 02 OF 03	
NODE NUMBER	(NODENUM) <input type="text"/>
SLOT NUMBER	(SLOTNUM) <input type="text"/>
PRIMARY MODULE POINT ID	(PRIMMOD) <input type="text" value="-----"/>
F1=PED      F3=      F5=OVERWRITE      F7=RECON      F9 =WLK BACK      F11= F2=RECALL DISP      F4=      F6=      F8=PED STATUS      F10=WRITE      F12=LOAD	

14227

# A.10 Numeric, Continued

Page 3 of 3

PED >>>>>> POINT:		UNIT:	UNENTERED	PAGE 03 OF 03
02 May 95 15:36:47 3				
NIM- PV CONFIGURATION NUMERIC				
PV	(PV)	<input type="text" value="0.0"/>		
PV DECIMAL FORMAT	(PVFORMAT)	<input type="text" value="D0"/>	<input checked="" type="text" value="D1"/>	<input type="text" value="D2"/> <input type="text" value="D3"/>
F1=PED	F3=	F5=OVERWRITE	F7=RECON	F9 =WLK BACK
F2=RECALL DISP	F4=	F6=	F8=PED STATUS	F10=WRITE
				F11=
				F12=LOAD

14228



# Index

---

## A

Alarm contacts 35  
Analog Input 66  
Analog Output 68

## B

Building SMM data points 63

## C

Cabinet entry 6  
Cabinet ground connections 37  
Cabinet Installation 19  
Cabinet power connections 34  
Cable conduit 21  
Cable trays 21  
Cabling

- card file to card file 26
- non-redundant 28
- redundant 29
- SMM 27
- TRISTATION 33

Cabling guidelines 25  
Card file 26  
Card File Configuration 45  
Card File Installation 20  
Card file power connections 35  
Chassis

- expansion 45
- RXM 46

Communication equipment grounding 39  
Communication module wiring 33  
Conduit Spacing 24  
Configuration data

- downloading 51
- saving 51

Configuration Overview 44  
Configuration Parameters 50

## D

Data signal cable 22  
Dictionary Editor 53  
Digital Composite 74  
Digital Input 70  
Digital Output 73  
Downloading SOE data 55

## E

Engineering Main Menu display 58  
Expansion chassis 45  
External Termination Module 30, 32

## F

Fiber-optic remote extender module 46  
File Manager screen 51  
Flag 81  
Fork lift 11

## G

Grounding

- cabinet connections 37
- communication equipment 39
- safety 38
- shield 39
- signal 38

Grounding considerations 36

## H

High level conductors 24  
History Module. 56  
Humidity 2

## I, J, K

I/O module wiring 30  
Installation checklist 18  
Internal Termination Module which 30

## L

Ladder Editor 53  
Logic 78  
Low level conductors 24

# Index

---

## M

Main chassis *45*  
    Safety Manager *45*  
    TRICON *44*  
Mobile lifter *12*  
Module Configurator screen *49*  
Move  
    crane method *16*  
    fork lift *11*  
    mobile lifter *12*  
    roller method *15*  
Move checklist  
    cabinets *4*  
    electronics room *5*  
Moving *10*  
MP Clock *50*

## N, O

Network configuration. *56*  
NIM Build Type Select Menu display *59*  
Node address *50*  
Node-specific configuration *61*  
Noise generation *22*  
Noise susceptibility *22*  
Numeric *84*

## P, Q

Power connections  
    cabinet *34*  
    card file *35*  
Power supply wiring *30*  
Process Point Building display *62*  
Prohibit writes *50*

## R

Raceway Shielding *21*  
Redundant SMM modules *44*  
RXM chassis *46*

## S

Safety ground *38*  
Saving SOE data *55*  
Sequence of Events (SOE) Configuration *53*  
Shield ground *39*  
Shielding *21*

Signal ground *38*  
SMM cabling *27*  
    non-redundant *28*  
    redundant *29*  
SMM data points *63, 65*  
SOE block *50*  
SOE block configuration *53*  
SOE control program *53*  
Spacing *22*  
Storage ratings *2*  
System Ground Connections *36*  
System Power Connections *34*  
System status display *57*

## T

Temperature *2*  
Test equipment *1*  
Timer *82*  
Tools *1*  
Tray Spacing *23*  
Tray/Conduit Spacing *23*  
TRICON's main chassis *44*  
TRISTATION cabling *33*  
TRISTATION UCN Configuration *48*  
TRISTATION UCN configuration parameters *50*  
Trunk cable connection *42*

## U

UCN configuration *48*  
UCN installation *40*  
UCN Node Configuration display *59*  
UCN test mode *50*  
Universal Personality *57*  
Unpacking *10*  
US Configuration *56*

## V

Verifying configuration completion *52*

## W, X, Y, Z

Wiring  
    communication module *33*  
Wiring classifications *22*  
Wiring guidelines *25*

# READER COMMENTS

Honeywell's IAC Automation College welcomes your comments and suggestions to improve future editions of this and other publications.

You can communicate your thoughts to us by fax, mail, or toll-free telephone call. We would like to acknowledge your comments; please include your complete name and address.

**BY FAX:** Use this form; and fax to us at (602) 313-4108.

**BY TELEPHONE:** In the U.S.A. use our toll-free number 1\*800-822-7673 (available in the 48 contiguous states except Arizona; in Arizona dial 1-602-313-5558).

**BY MAIL:** Use this form; detach, fold, tape closed, and mail to us.

Title of Publication: **Safety Manager Module Installation Guide**      Issue Date: **4/96**  
Publication Number: **SM20-500**  
Writer: **Ray Snyder/Vernadine Merrick**

**COMMENTS:** \_\_\_\_\_  
\_\_\_\_\_  
\_\_\_\_\_  
\_\_\_\_\_  
\_\_\_\_\_  
\_\_\_\_\_  
\_\_\_\_\_  
\_\_\_\_\_  
\_\_\_\_\_

**RECOMMENDATIONS:** \_\_\_\_\_  
\_\_\_\_\_  
\_\_\_\_\_  
\_\_\_\_\_  
\_\_\_\_\_  
\_\_\_\_\_  
\_\_\_\_\_

NAME \_\_\_\_\_ DATE \_\_\_\_\_  
TITLE \_\_\_\_\_  
COMPANY \_\_\_\_\_  
ADDRESS \_\_\_\_\_  
CITY \_\_\_\_\_ STATE \_\_\_\_\_ ZIP \_\_\_\_\_

(If returning by mail, please tape closed; Postal regulations prohibit use of staples.)

Communications concerning technical publications should be directed to:

Automation College  
Industrial Automation and Control  
Honeywell Inc.  
2820 West Kelton Lane  
Phoenix, Arizona 85023

FOLD

FOLD

From: \_\_\_\_\_  
\_\_\_\_\_  
\_\_\_\_\_



NO POSTAGE  
NECESSARY  
IF MAILED  
IN THE USA

**BUSINESS REPLY MAIL**  
FIRST CLASS      PERMIT NO. 4332      PHOENIX, ARIZONA

POSTAGE WILL BE PAID BY ....

**Honeywell**

**Industrial Automation and Control  
2820 West Kelton Lane  
Phoenix, Arizona 85023**

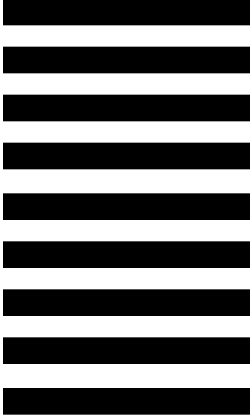

Cut Along Line

Attention: Manager, Quality

FOLD

FOLD

Additional Comments:



**Honeywell**

---

**Industrial Automation and Control**  
Honeywell Inc.  
16404 North Black Canyon Highway  
Phoenix, Arizona 85023-3099

*Helping You Control Your World*