

Keyboards

SW09-508

**Implementation
Engineering Operations - 1**

Keyboards

**SW09-508
Release 510
2/96**

Copyright, Notices, and Trademarks

© Copyright 1995 by Honeywell Inc.

Revision 02 – February 28, 1996

While this information is presented in good faith and believed to be accurate, Honeywell disclaims the implied warranties of merchantability and fitness for a particular purpose and makes no express warranties except as may be stated in its written agreement with and for its customer.

In no event is Honeywell liable to anyone for any indirect, special or consequential damages. The information and specifications in this document are subject to change without notice.

This document was prepared using Information Mapping® methodologies and formatting principles.

TDC 3000 is a trademark of Honeywell Inc.

Information Mapping is a trademark of Information Mapping Inc.

Honeywell
Industrial Automation and Control
Automation College
2820 West Kelton Lane
Phoenix, AZ 85023

(602) 313-5669

About This Publication

This publication defines the keyboards used with the TDC 3000^X Local Control Network (LCN) Universal Station, Universal Station^X, Universal Work Station, and Micro TDC 3000 systems.

There are other discussions of keyboards in various publications in the bookset, but this is the only complete and up-to-date discussion of all of the LCN keyboards.

This version of this publication supports Release 510. The Integrated Keyboard discussion has been added as Section 7.

Change bars are used to indicate paragraphs, tables, or illustrations containing changes that have been made to this manual effective with Release 500. Pages revised only to correct minor typographical errors contain no change bars.

Table of Contents

SECTION 1 – INTRODUCTION.....	1
1.1 Overview.....	1
1.2 Original Operator's Keyboard.....	3
1.3 Alphabetic Keyboard.....	4
1.4 QWERTY Operator's Keyboard.....	5
1.5 Fixed Engineer's Keyboard.....	6
1.6 Roving Engineer's Keyboard.....	7
1.7 U ^X S Auxiliary Keyboard.....	8
1.8 Integrated Keyboard.....	9
SECTION 2 – OPERATOR'S KEYBOARD.....	11
2.1 Overview.....	11
2.2 Operator's Keyboard Description.....	11
2.3 Bottom Three Rows of Buttons.....	13
2.4 Reset Switch and Power Indicators.....	13
2.5 Standard Section — Second Row.....	14
2.6 Standard Keys — Left Column.....	16
2.7 Standard Numeric Keys.....	20
2.8 Alarm Functions.....	21
2.9 Operator Control Keys.....	23
SECTION 3 – FIXED ENGINEER'S KEYBOARD.....	27
3.1 Overview.....	27
3.2 Generic Function Keys.....	29
3.3 Function Keys.....	31
SECTION 4 – ROVING ENGINEER'S KEYBOARD.....	33
4.1 Overview.....	33
4.2 Generic Function Keys.....	34
4.3 Function Keys.....	36
4.4 Programmable Function Keys PF1–PF17.....	38
4.5 Configuring Keyswitch Buttons.....	40
SECTION 5 – U^XS AUXILIARY KEYBOARD.....	41
5.1 Overview.....	41
5.2 Generic function Keys.....	42
5.3 Function Keys.....	44
5.4 Programmable Function Keys PF1–PF17.....	46
5.5 Configuring Keyswitch Buttons.....	48
SECTION 6 – U^XS AUXILIARY KEYBOARD IN EMULATION MODE.....	49
6.1 Overview.....	49
6.2 Main Function Keys.....	50
6.3 Editing Function Keys.....	52
6.4 Numeric Function Keys.....	53
6.5 Top Row Function Keys.....	54
6.6 Keyboard Mapping in teem-X.....	55

Table of Contents

SECTION 7 – INTEGRATED KEYBOARD.....	61
7.1. Overview.....	61
7.2 Console Mounted Integrated Keyboard.....	62
7.3 Desktop Integrated Keyboards	63
7.4 IKB Functional Partition Description.....	64
7.5 Full Travel Keyboard.....	65
7.6 Relegendable Function Key Panel.....	68
7.7 Operator Control Panel.....	69

Figures and Tables

Figure 1-1	Original Operator's Keyboard.....	3
Figure 1-2	Alphabetic Operator's Keyboard	4
Figure 1-3	QWERTY Operator's Keyboard.....	5
Figure 1-4	Fixed Engineer's Keyboard	6
Figure 1-5	Roving Engineer's Keyboard.....	7
Figure 1-6	UXS Auxiliary Keyboard.....	8
Figure 1-7	Integrated Keyboard	9
Figure 1-8	Desktop Integrated Keyboard.....	9
Figure 2-1	Standard Keys—Left Column	16
Figure 2-2	Operator Keyboard—Numeric Keypad	20
Figure 2-3	Alarm Function Section	21
Figure 2-4	Operator Control Keys.....	23
Figure 3-1	Fixed Engineer's Keyboard	28
Figure 3-2	Fixed Engineer's Keyboard	28
Figure 3-3	Generic Function Key Designations	29
Figure 4-1	Roving Engineer's Keyboard Key Designations.....	34
Figure 4-2	Button Configuration Display for PF1–PF17	39
Figure 4-3	Button Configuration Display for Specifying Key Actions	40
Figure 5-1	UXS Auxiliary Keyboard Key Designations.....	42
Figure 5-2	Button Configuration Display for PF1–PF17	47
Figure 5-3	Button Configuration Display for Specifying Key Actions	48
Figure 6-1	UXS Auxiliary Keyboard Key Designations.....	49
Figure 6-2	UXS Auxiliary Keyboard Main Keypad.....	50
Figure 6-3	UXS Auxiliary Keyboard Editing Keypad	52
Figure 6-4	UXS Auxiliary Keyboard Numeric Keypad.....	53
Figure 6-5	UXS Auxiliary Keyboard Top Row Keys.....	54
Figure 7-1	Integrated Keyboard with Trackball.....	62
Figure 7-2	Desktop Integrated Keyboard.....	63
Figure 7-3	Full Travel Keyboard.....	65
Figure 7-4	Relegendable Function Key Panel.....	68
Figure 7-5	Operator's Control Panel	69
Table 6-1	Key Codes	55

References

Publication Title	Publication Number	Binder Title	Binder Number
<i>Process Operations Manual</i>	SW11-501	Operation/Process Operations	TDC 3050
<i>Data Entity Builder Manual</i>	SW11-511	Implementation/Engineering Operations - 1	TDC 3032-1

Section 1 – Introduction

1.1 Overview

Section contents These are the topics covered in this section:

	Topic	See Page
	SECTION 1 – INTRODUCTION.....	1
1.1	Overview.....	1
1.2	Original Operator's Keyboard.....	3
1.3	Alphabetic Keyboard.....	4
1.4	QWERTY Operator's Keyboard.....	5
1.5	Fixed Engineer's Keyboard.....	6
1.6	Roving Engineer's Keyboard.....	7
1.7	U ^X S Auxiliary Keyboard.....	8
1.8	Integrated Keyboard.....	9

Keyboards

There are three Operator's Keyboards in use on TDC 3000^X Local Control Network (LCN) equipment.

- Operator's Keyboard (original alphabetic)
- Operator's Keyboard (new alphabetic)
- Operator's Keyboard (QWERTY)

There are three Engineer's Keyboards in use on LCN equipment.

- Engineer's Keyboard (fixed mounting)
- Engineer's Keyboards (roving)
- U^XS Auxiliary Keyboard (roving)

Operator's Keyboards are located in Universal Stations (USs) and Universal Stations^Xs (U^XSs). Engineer's Keyboards are an optional part of Universal Stations. The Universal Station^X has a U^XS Auxiliary Keyboard that provides the standard LCN functions as well as functionality for the emulation mode when connected through a Plant Information Network (PIN) to a system outside the LCN.

Operator's Keyboard (original)

The original Operator's Keyboard is shown in Figure 2-1. The functional description of each special key or group of keys is found in Section 2.

Continued on next page

1.1 Overview, Continued

Operator's Keyboard (new)

The new Operator's Keyboard has two different key configurations for data entry.

- The alphabetic key arrangement has the same configuration of data entry keys that the original Operator's Keyboard, as shown in Figure 2-2.
- The QWERTY Operator's Keyboard has the key configuration of a standard typewriter. Figure 2-3 shows this configuration. Section 3 has the functional description of this keyboard.

These two keyboards are used on all products since Release 300.

Engineer's Keyboard (Fixed)

The original Fixed Engineer's Keyboard is shown in Figure 3-1. This keyboard is mounted in the bezel with Operator's Keyboard (all three versions). The functional description of this keyboard can be found in Section 4.

Roving Engineer's Keyboard

The Roving Engineer's Keyboard is used with:

- USs built with software Release 300 systems and later.
- Universal Work Stations (UWS)
- Micro TDC 3000 Systems.

The Roving Engineer's Keyboard is shown in Figure 4-1. The discussion in Section 5 describes the special key functions.

UXS Auxiliary Keyboard

The U^XS Auxiliary Keyboard is a roving keyboard used on Universal Station^X. It is shown in Figure 5-1 located in Section 5, which also defines the functional description

The U^XS Auxiliary Keyboard can be used to emulate the keyboard of other equipment. Section 6 defines this functionality.

1.2 Original Operator's Keyboard

Illustration

Figure 1-1 Original Operator's Keyboard

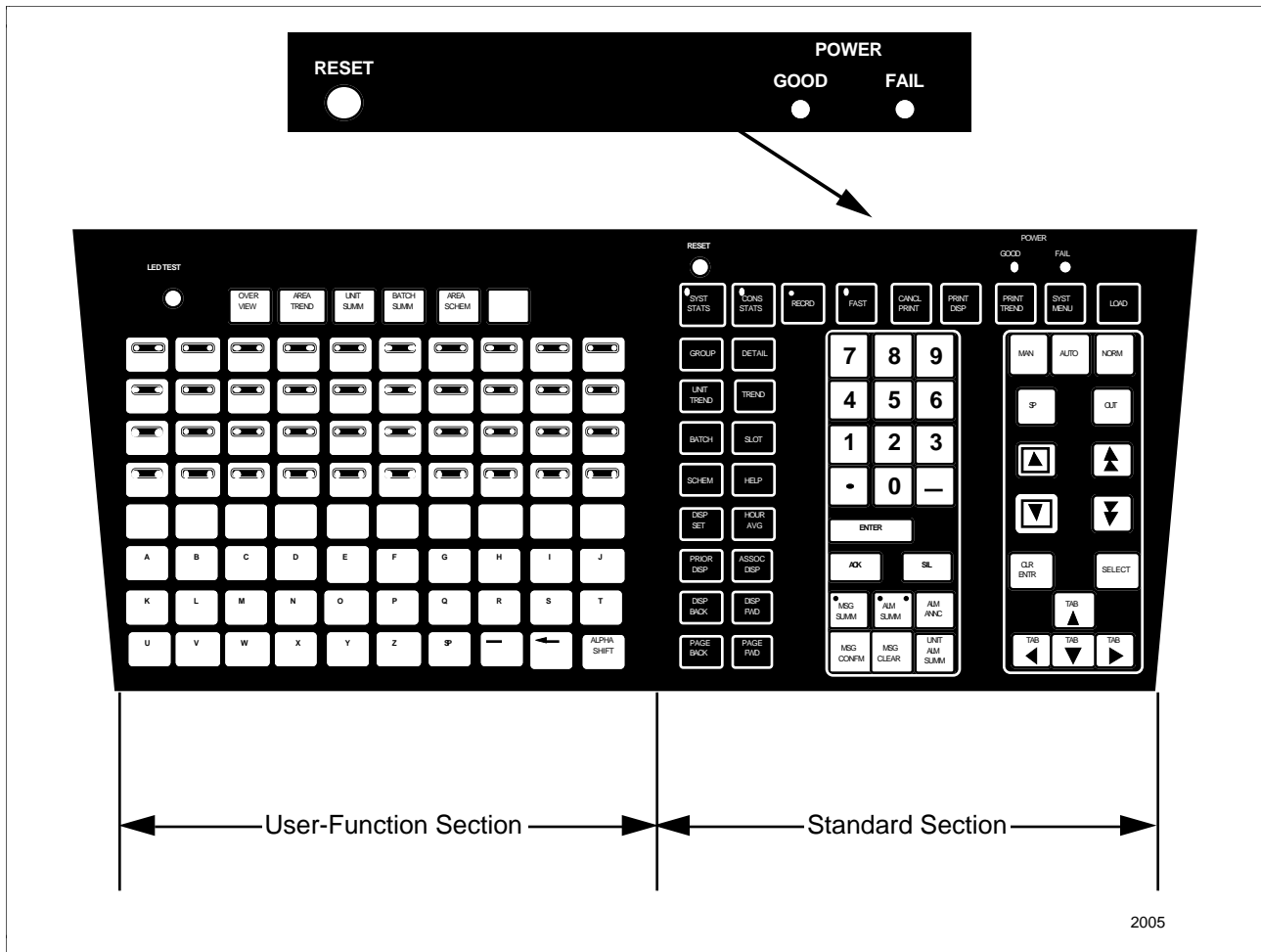

Continued on next page

1.3 Alphabetic Keyboard

Illustration

Figure 1-2 Alphabetic Operator's Keyboard

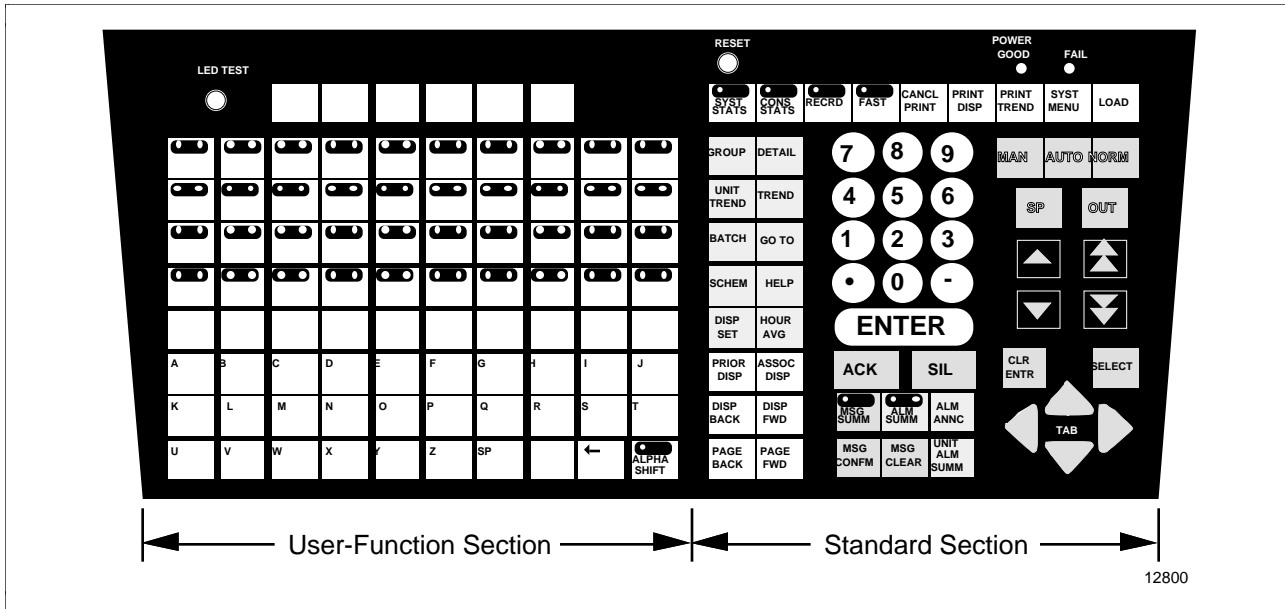

1.4 QWERTY Operator's Keyboard

Illustration

Figure 1-3 QWERTY Operator's Keyboard

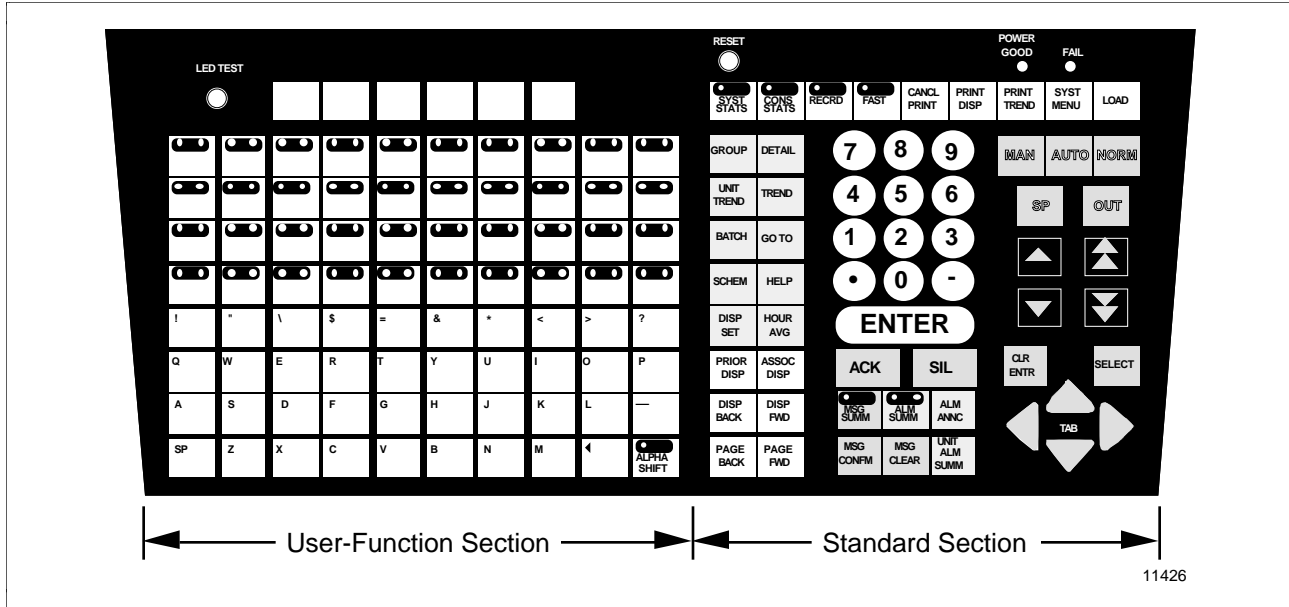

1.5 Fixed Engineer's Keyboard

Illustration

Figure 1-4 Fixed Engineer's Keyboard

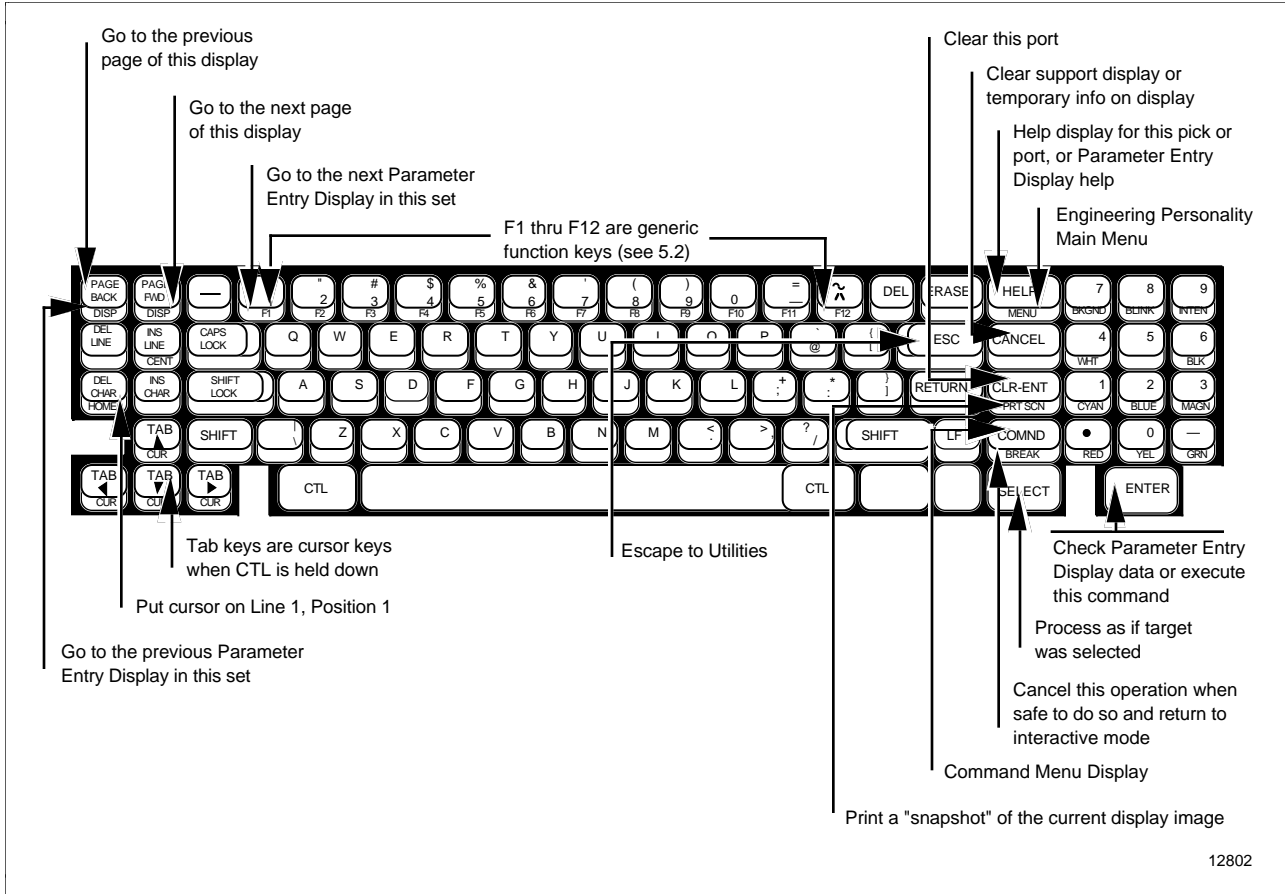

12802

1.6 Roving Engineer's Keyboard

Illustration

Figure 1-5 Roving Engineer's Keyboard

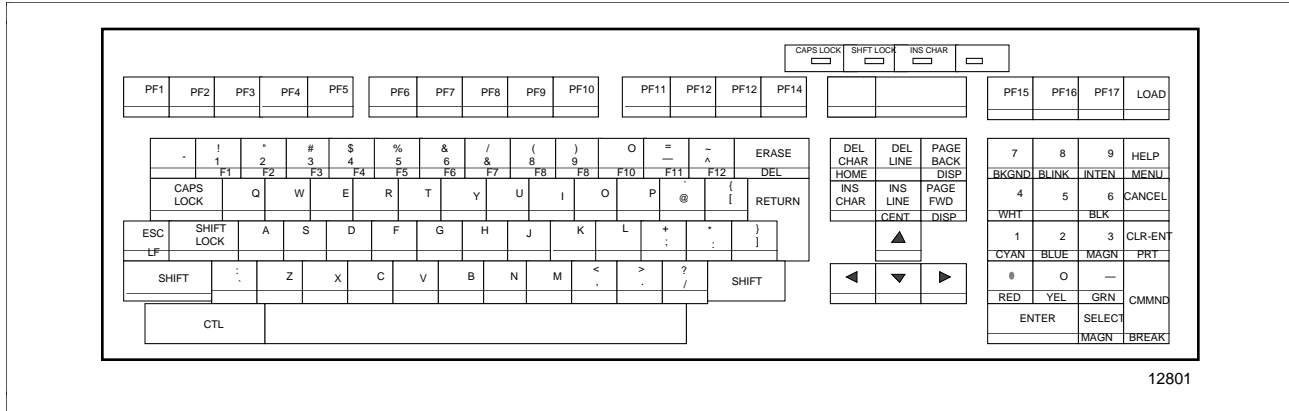

12801

1.7 UXS Auxiliary Keyboard

Illustration

Figure 1-6 UXS Auxiliary Keyboard

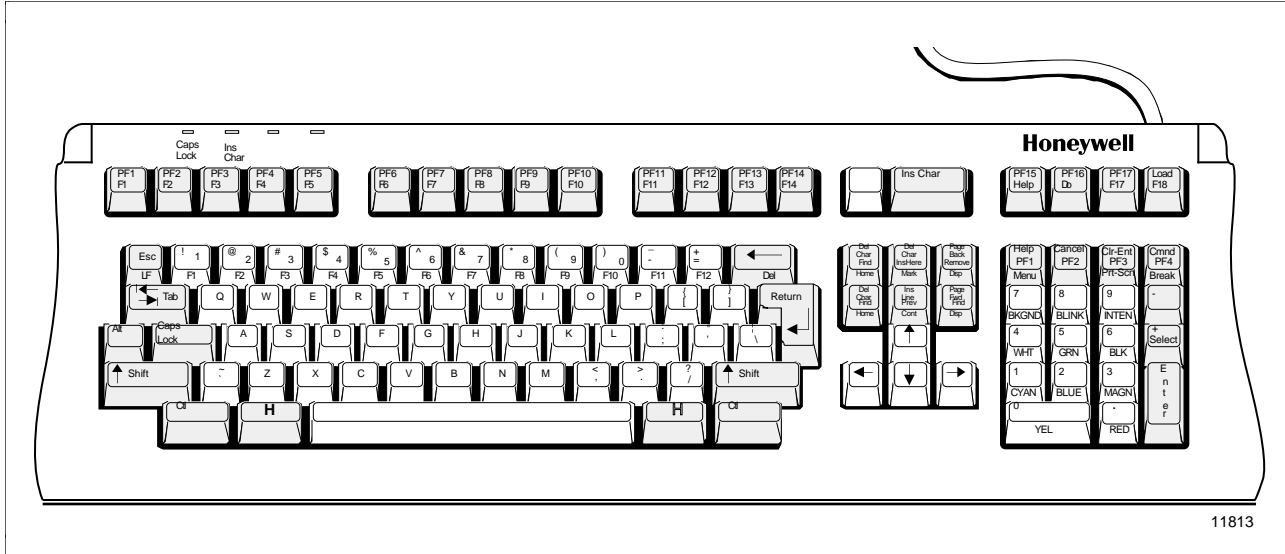

1.8 Integrated Keyboard (IKB)

Illustration

Figure 1-7 Integrated Keyboard Mounted on Console Furniture



Figure 1-8 Desktop Integrated Keyboard

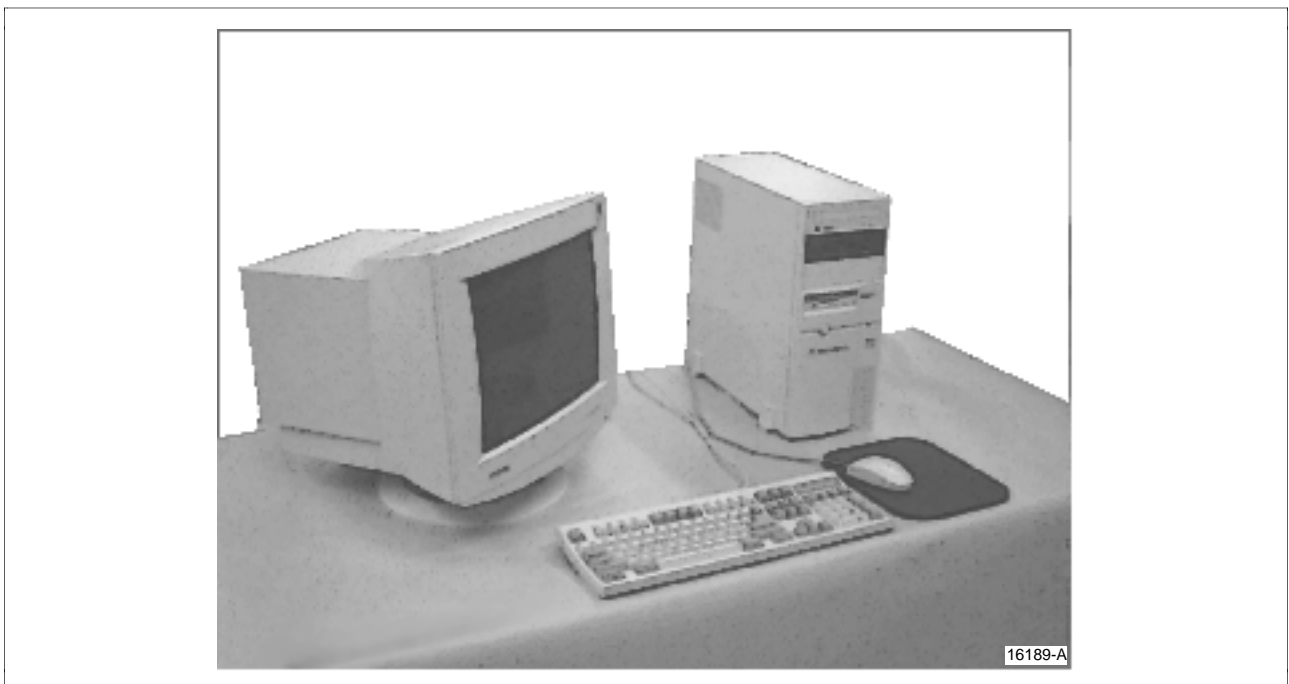

Section 2 – Operator’s Keyboard

2.1 Overview

Section contents These are the topics covered in this section:

	Topic	See Page
	SECTION 2 – OPERATOR’S KEYBOARD.....	11
2.1	Overview.....	11
2.2	Operator’s Keyboard Description.....	11
2.3	Bottom Three Rows of Buttons.....	13
2.4	Reset Switch and Power Indicators.....	13
2.5	Standard Section — Second Row.....	14
2.6	Standard Keys — Left Column.....	16
2.7	Standard Numeric Keys.....	20
2.8	Alarm Functions.....	21
2.9	Operator Control Keys.....	23

2.2 Operator’s Keyboard Description

Configurations

Two configurations of the TDC 3000^X Operator’s Keyboard are in use. The primary difference between the two configurations is cosmetic—the functionality is identical. The newer configuration has two versions. All three keyboards are shown in Figure 1-1 through Figure 1-3.

The only difference between the two new configurations is the arrangement of the alpha keys at the lower left. The model illustrated in Figure 1-3 features the alpha keys arranged like those of a standard typewriter keyboard (QWERTY); the other two keyboards shown in Figure 1-1 and Figure 1-2 have these keys arranged alphabetically. All three types of keyboards are illustrated in this section. All of the keyboards are divided into two major sections: the standard keys and the user-function buttons.

The remaining keys of the two types of keyboards are nearly identical and all perform the same functions—to allow the operator to call up displays, control cursor movement, enter operating data, and do other operating functions described in this section of the manual.

The standard keys are on the right side of the keyboard as shown in Figure 2-1. Standard keys are those that have been predefined by Honeywell to perform certain specific functions. These keys are generally not subject to change, once their functions have been defined and the keys have been labeled. Some of the standard keys are backlit to announce certain process events or to indicate specific states.

Continued on next page

2.2 Operator's Keyboard Description, Continued

Keys and Buttons

The term KEYS is used in this manual to refer to the standard operator keys on the right side of the keyboard. The term BUTTON is sometimes used to refer to the user-functions (or user-configurable functions) on the left side of the operator's keyboard.

The user-function buttons are those 85 buttons on the left side of Figure 2-1. These are buttons that the user can define or configure to perform certain functions, such as the callup of certain critical or frequently used displays, or cross-screen displays within a console, or to activate a particular Control Language program.

Buttons 7 through 46 are dual backlighted in red and yellow to allow configuration for alarm annunciation (refer to the publications *Button Configuration Form Instructions* and *Button Configuration Data Entry* for button configuration). Refer to Sections 7 and 8 of the *Process Operations Manual* for Alarm Annunciation.

LED test switch

This switch is located at the top left corner of the user-function section. This is not an LED; it is a switch used to test the operation of the keyboard LEDs, when pressed.

2.3 Bottom Three Rows of Buttons

Description

The bottom three rows of the user-function buttons can serve as both user-defined functions or alphabetic-entry buttons, depending on the current operating mode of the keyboard. The keyboard mode can be changed by pressing the Alpha Shift button, shown at the bottom right of the user-function section. To enter alphabetic characters (for example, tag names, Unit IDs) from the Operator's Keyboard, using the last three rows of user-function buttons:

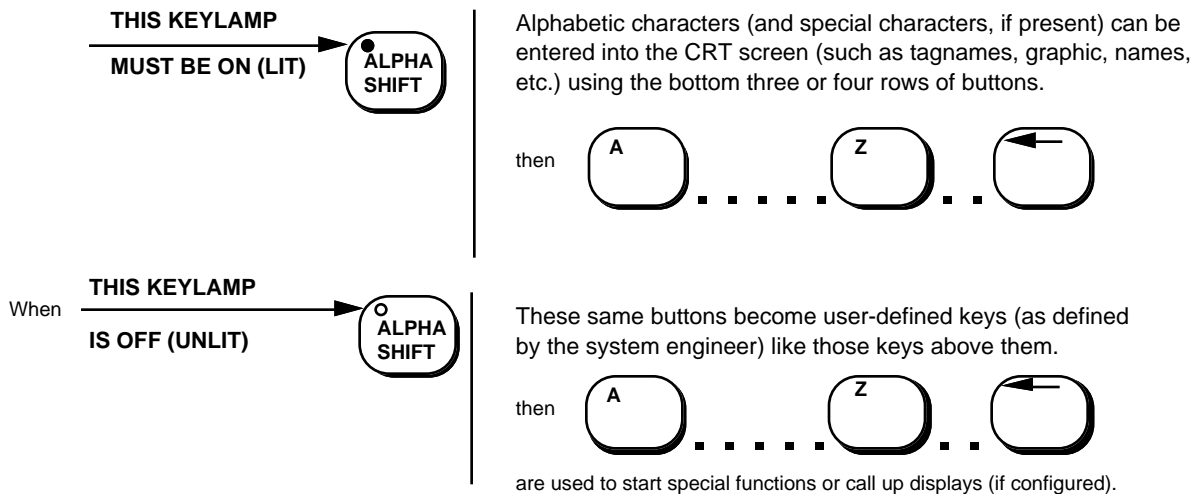

2.4 Reset Switch and Power Indicators

Reset

Resets the Universal Station hardware; does the same thing as the white reset button on any LCN Module.

Power Good



The indicator is lit if all power supplies are operating within their correct voltage ranges.

Fail Indicator

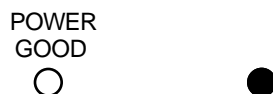

The FAIL indicator is lit if there is a hardware failure in the Universal Station.

2.5 Standard Section — Second Row

Illustration



System Status



System Status key—Calls up the System Status Display. Key backlight blinks when there is an unacknowledged system alarm and is steady when alarm(s) is ACKnowledged.

Console Status



Console Status key—Calls up the Console Status and Assignments Display. Key backlight blinks when there is an unacknowledged console alarm and is steady when alarm(s) is ACKnowledged.

Trend Pen Record



Trend Pen Record key—Activates trend-pen recording of a selected point. Trend pen recording is activated from the Operating Group Display by pressing the RECRD key. This key is backlit while recording is in progress. Pressing the key a second time terminates the recording operation.

Fast

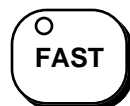

Fast update key—(1) Causes the update rate for hiway-related display information to increase to 2-second intervals instead of the standard update rate of once every 4 seconds. An example is to press the FAST key while viewing a group display. (2) Can cause certain parameters in Graphic (Custom) Displays to update twice a second, if so configured.

The key backlight comes On for fast update selected.

Continued on next page

2.5 Standard Section — Second Row, Continued

Cancel Print



Cancel Print key—Used to abort any currently printing output on any printer in the console. When pressed, the prompt asks the operator to enter the console-related printer number. Cancel Print does not function across stations with different personalities.

Print Display



Print Display Key—The display currently on the screen is printed on the stations assigned printer.

Print Trend



Print Trend key—Activates trend printing for a selected point. Trends for all points in an operating group can be printed on the Matrix Printer.

System Menu



System Menu key—Calls up the System Menu Display.

Load



Load key—Prepares the Universal Station for personality loading.

2.6 Standard Keys — Left Column

Illustration

Figure 2-1 Standard Keys—Left Column

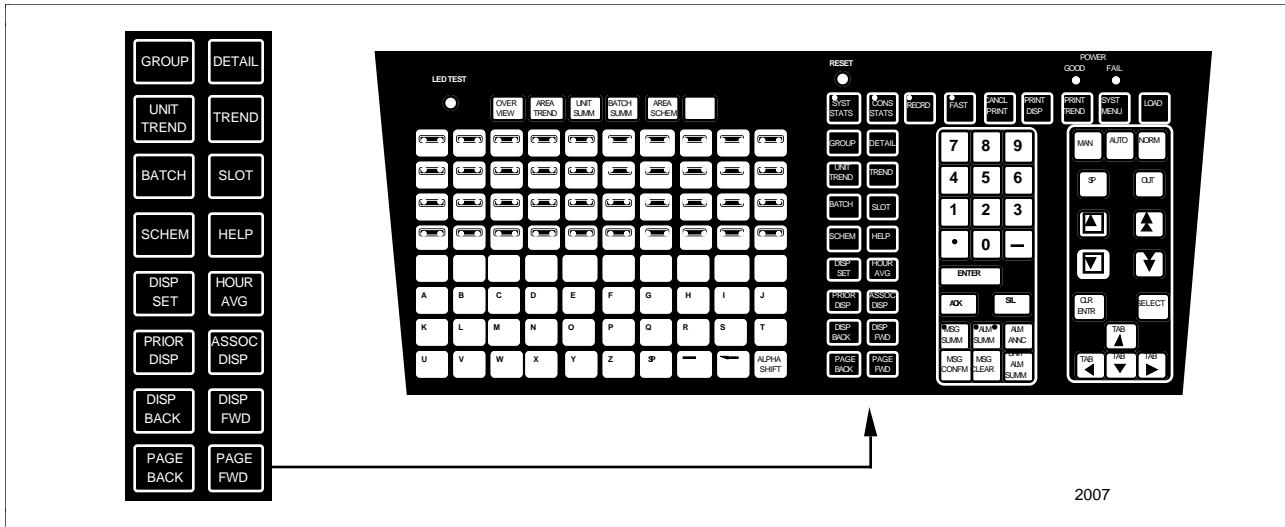

Group



Group display key—Calls up the Group Display; requires entry of a Group Number.

Detail



Detail display key—Calls up the detail display; requires entry of a Tagname (Point ID).

Unit Trend



Unit Trend key—Calls up the Unit Trend Display; requires entry of a Unit ID.

Continued on next page

2.6 Standard Keys — Left Column, Continued

Trend



Trend key—Calls up the Group Trend Display from the Operating Group Display by selecting a point to be trended and pressing the Trend key.

Batch



The functionality of this key is deferred.

Go To



Go To key—Used to select a point on the Group Display; requires entry of the desired Point Number, 1–8.

Schematic



Schematic key—Calls up a graphic Schematic Display; requires entry of a Schematic name.

Help



Help key—Calls up a preconfigured operator Help display associated with the current display. The Help display could take the form of a prompt, a maintenance suggestion, or a reference to a related display for additional information.

Display Set



Not Implemented.

Continued on next page

2.6 Standard Keys — Left Column, Continued

Hourly Average



Hourly Averages key—Calls up the Hourly Averages Display from the Operating Group Display.

Prior Display



Prior Display key—Calls up the display that was shown immediately before the current display. If pressed while viewing a Group Trend Display, it cancels the Group Trend Display and returns to the Group Display.

Associated Display



Associated Display key—Calls up the configured display associated with an item chosen from the current display.

Display Back



Display Back key—Calls up the next lower numbered display within the same type of display as the current display. For example, if Group Display 250 is on the screen and DISP BACK is pressed, Group Display 249 is called up.

Display Forward



Display Forward key—Calls up the next higher-numbered display within the same type of display as the current display. As an example, the Display Forward key is used when going from Group Display 5 to Group Display 6.

Continued on next page

2.6 Standard Keys — Left Column, Continued

Page Back



Page Back key—Calls up the next lower-numbered page of a multiple page display.

Page Forward



Page Forward key—Calls up the next higher-numbered page of a multiple page display.

Both Page Forward and Page Back keys have a wraparound feature. In other words, if Page Forward is requested from the last page of a multiple-page display, the first page of the display is called up. Wraparound also applies when paging in the opposite direction.

2.7 Standard Numeric Keys

Illustration

Figure 2-2 Operator Keyboard—Numeric Keypad

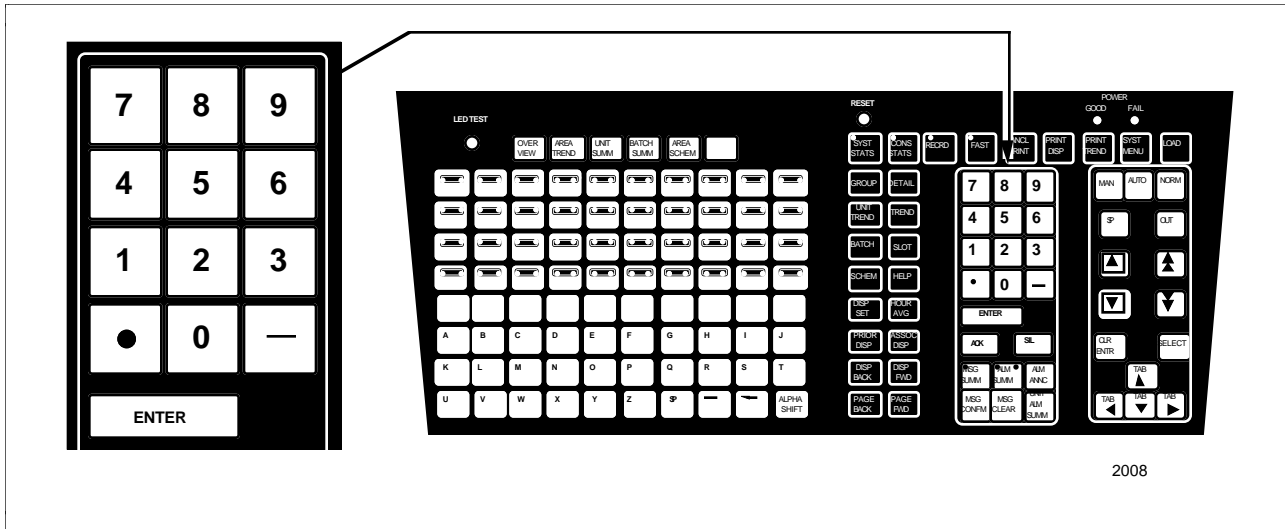

2008

Standard Numeric Touchpad

Numeric values are displayed on the screen in the data-entry field character-by-character, as they are entered. The ENTER key is pressed to complete the data entry. The value entered is transmitted to the owner of the data, and the display is updated to reflect the new value. The CLEAR ENTRY key is pressed to erase incorrect or unwanted keystrokes.

2.8 Alarm Functions

Illustration

Figure 2-3 Alarm Function Section

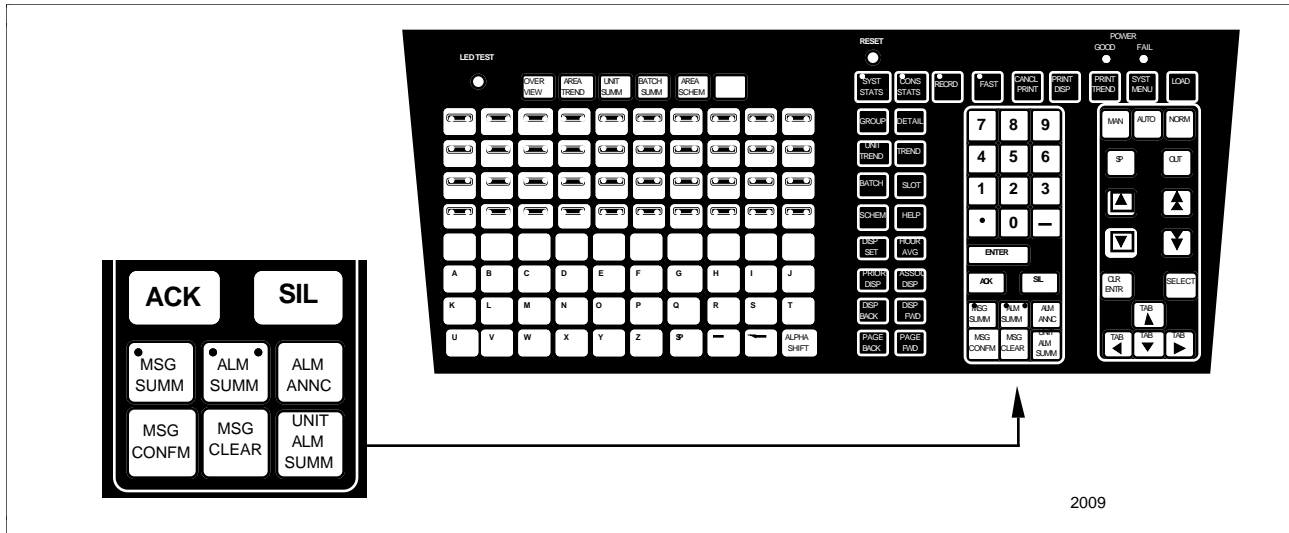

Alarm Acknowledge



Alarm Acknowledge key—Acknowledges all Process Alarms or System Status Alarms for the console; must be used when an Alarm or System Status Display is on-screen. Silences the Audible Alarm, if it has not already been silenced.

Silence



Silence key—Silences all audible alarms in the console.

Message Summary



Message Summary key—Calls up the Message Summary Display. The key is backlit and blinks whenever there are messages that require operator acknowledgment. The key is lit steadily whenever all messages have been acknowledged, but messages exist that require operator confirmation.

Continued on next page

2.8 Alarm Functions, Continued

Alarm Summary



Alarm Summary key—Calls up the Area Alarm Summary Display. The Alarm Summary key lights whenever an Alarm Event is received by the Universal Station, and remains lit as long as alarms exist in the area. There are two backlights, red and yellow, that indicate the Priority and Acknowledgment state of the alarms; refer to Sections 7 and 8 of the *Process Operation Manual* for details.

Alarm Annunciator



Alarm Annunciator display key—Calls up the Alarm Annunciator Display.

Message Confirm



Message Confirmation key—This key is associated with the Message Summary Display. Messages are acknowledged and/or confirmed (if necessary) from this display. Position the cursor to any message desired on the display (using Fast Raise/Lower keys), and press the Message Confirmation Key to confirm the message. Confirmation is message-by-message.

Message Clear



Message Clear key—This key is used to clear messages that have been acknowledged and confirmed on the Message Summary Display. Clearing is page-by-page.

Unit Alarm Summary



Unit Alarm Summary key—Calls up the Unit Alarm Summary Display; requires entry of a Unit ID.

2.9 Operator Control Keys

Illustration

Figure 2-4 Operator Control Keys

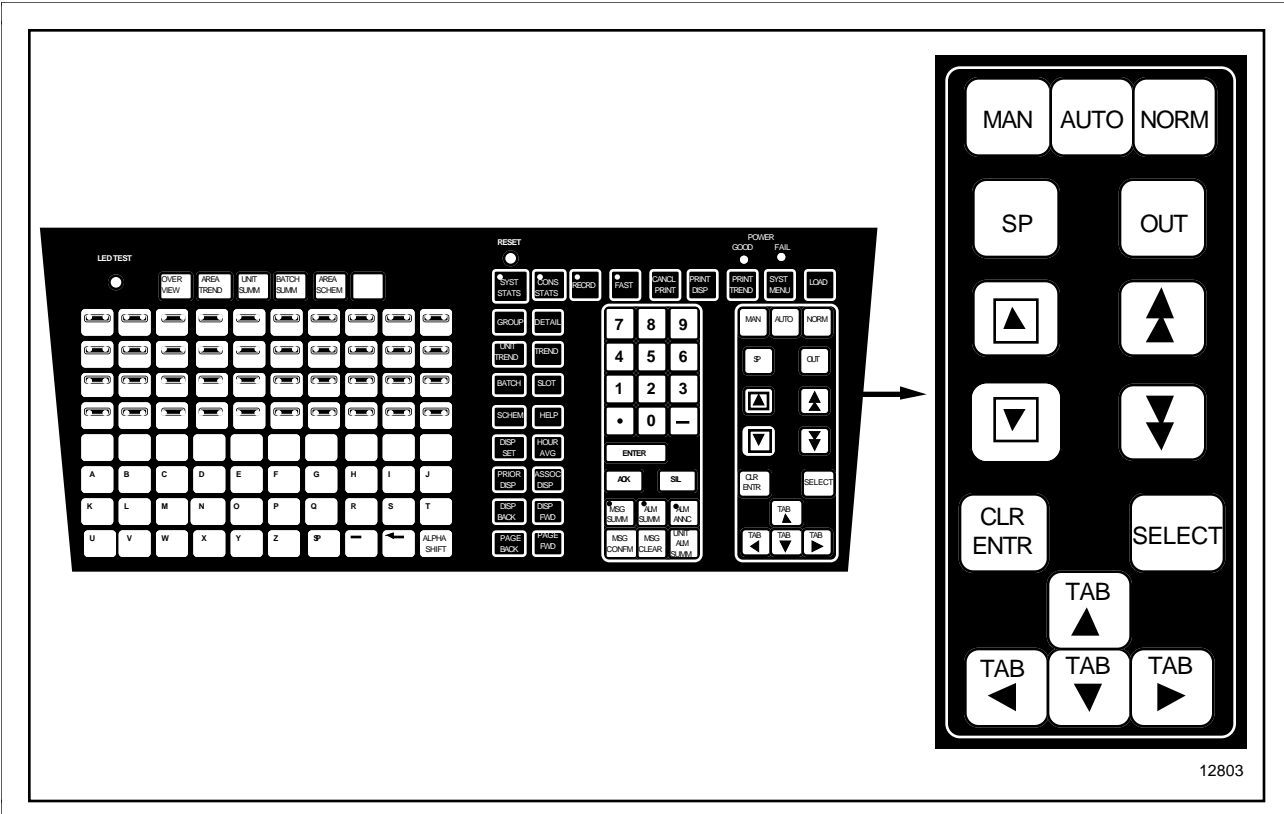

Manual Mode



Manual mode key—Places a selected point in manual mode; that is, the output is under direct control of the operator.

Auto



Automatic mode key—Places a selected point in automatic mode if configured for that mode. In automatic mode, the output (OP) value is calculated by a preconfigured algorithm using an operator-entered setpoint (SP).

Continued on next page

2.9 Operator Control Keys, Continued

Normal Mode



Normal mode key—Places the selected point in its NORMally configured mode.

Setpoint



Setpoint key—Permits changes to be made to setpoint values for a point. Pressing the Setpoint key allows changes of setpoint values to be entered either by the numeric keys, or by the Raise/Lower keys.

Output



Output key—Permits changes of Analog or Digital Output values. After the key is pressed (for example, while viewing a Detail Display), the Output value can be changed by a keyboard entry or by the Raise/Lower keys.

Continued on next page

2.9 Operator Control Keys, Continued

Digital State Change or Slow Raise/Lower



These two keys perform two functions. They serve as Digital State Change keys and slow-speed Raise/Lower functions.

Digital State Change—While viewing a Digital or Flag Point display, the up-arrow key can be configured to indicate an ON or OFF state of a Digital Output point. The down-arrow is configured for the opposite state. To change a Latch-type Digital Output state, the tagname must be selected, the Upper or Lower State Change key must be pressed, and the ENTER key must be pressed to complete the operation. Momentary-type Digital State selection does not require the ENTER key to complete the operation.

The Slow Raise/Lower operation allows the operator to increase or decrease a selected value or parameter shown on a display. When one of the single-arrow keys is tapped (pressed, then immediately released), the least-significant digit of the parameter is incremented or decremented by one. When the key is held down, the parameter is incremented/decremented by one percent of the full-scale range every 2/3 seconds.

Fast Raise/Lower



Fast Raise/Lower keys—Pressing the double up-arrow key causes the parameter to be increased at the configured fast rate, and pressing the double down-arrow key causes the parameter to be decreased at the configured fast rate. When either of the keys is held down, the parameter is increased/decreased every 2/3 of a second by the configured fast raise/lower rate.

The fast raise/lower rate is configured to change at the rate of 2, 3, 5, or 10 percent of the parameter's full-scale range, and is configured on a system basis.

Continued on next page

2.9 Operator Control Keys, Continued

Clear Entry



Clear Entry key—Clears an incorrect or unwanted operator entry at any time BEFORE the ENTER key is pressed.

Select



Select key—Selects the item at the current cursor position. If the cursor is positioned within an invisible or visible area, the target's function is called up by pressing the SELECT key.

Tab Keys

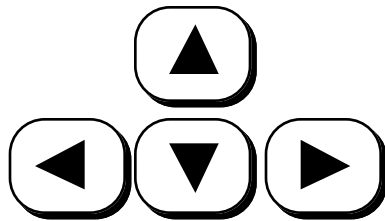

Tab keys—These four keys are used to position the cursor vertically or horizontally to any point on the display. The Tab Forward (right-arrow) key moves the cursor horizontally to the right, searching for the next tab character. The Tab Back (left-arrow) key tabs horizontally in the reverse direction. If a Tab key is held down, tabbing is continuous.

Section 3 – Fixed Engineer’s Keyboard

3.1 Overview

Section contents These are the topics covered in this section:

	Topic	See Page
	SECTION 3 – FIXED ENGINEER’S KEYBOARD.....	27
3.1	Overview.....	27
3.2	Generic Function Keys.....	29
3.3	Function Keys.....	31

Usage The Engineer's Keyboard is required for interaction with the Data Entity Builder. The keyboard has a QWERTY configuration similar to a typewriter. Most of the keys function as you would expect; however, there are several function keys that have specific DEB functions. These functions are summarized on Figure 3-1.

Key marking Several keys that have dual functions have dual markings—a symbol or symbols on the top of the key and another symbol or symbols on the front edge of the key. The secondary function indicated on the front edge of each of these keys is obtained when one of the two CTL keys is held down while the function key is pressed.

The color and behavior keys (BKGND, BLINK, INTEN, WHT, BLK, CYAN, BLUE, MAGN, RED, YEL, GRN) don't operate when you are using the DEB.

Function keys There are two groups of function keys on the Engineer's Keyboard: F1 through F12 are generic function keys that have unique DEB functions. The second group consists of all of the other function keys.

Continued on next page

3.1 Overview, Continued

Illustrations

Figure 3-1 Fixed Engineer's Keyboard

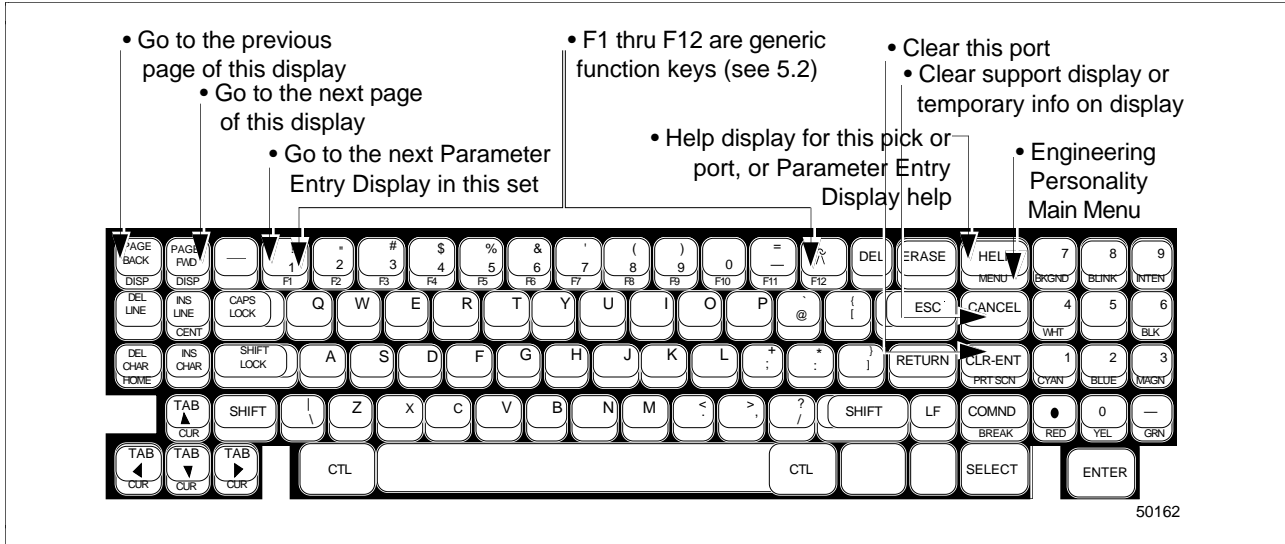
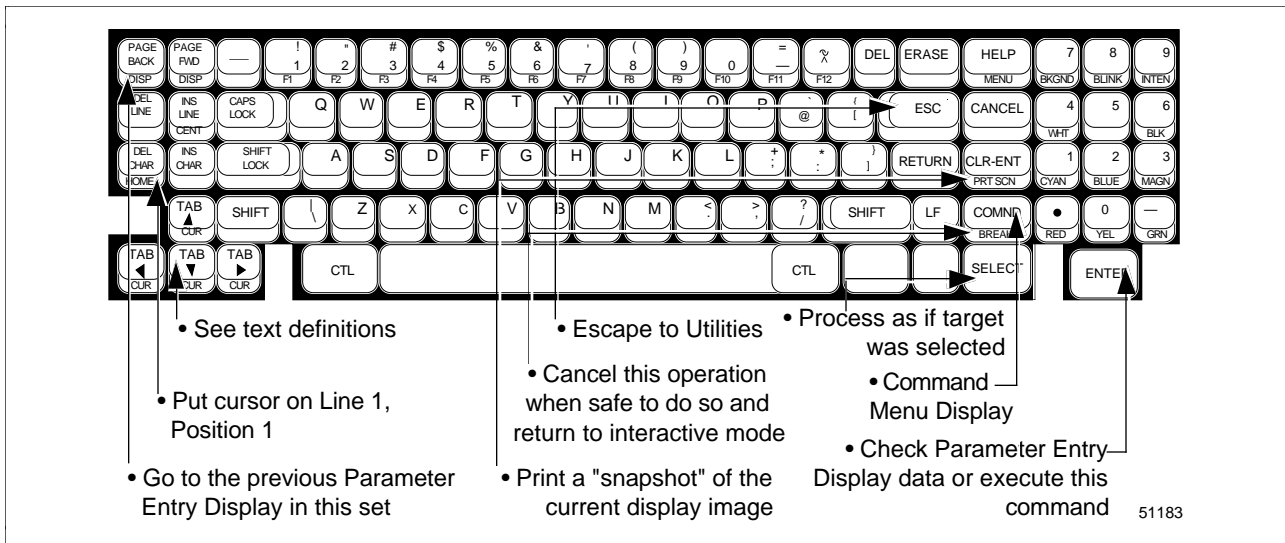

Figure 3-2 Fixed Engineer's Keyboard



3.2 Generic Function Keys

Description

The prompter region of the DEB displays shows labels for the twelve generic function keys, except when that region is needed for prompter or error messages. When it is necessary to replace these labels with a prompter or an error message, the labels are restored as soon as possible. Figure 5-2 shows a simulation of these labels.

Designation

Figure 3-3 Generic Function Key Designations

F1=PED	F3=	F5=OVERWRITE	F7=RECON	F9=WLK BACK	F11=
F2 = RECALL DISP	F4=	F6=	F8=PED STATUS	F10=WRITE	F12=LOAD

5548

Definition

Note that F1 through F12 are on dual function keys and to get one of the generic functions, CTL must be held down while the key is pressed.

The function of each of these keys is as follows:

- **F1=PED**—Recalls the last Parameter Entry Display (PED). If no PED has been on the screen in this session, this prompter appears: WARNING: NO PARAM. ENTRY DISPLAY TO RECALL.
- **F2=Recall Disp**—Recalls last support display (a PED help display, a display generated by a display command, or an error file display). If there is no such display to recall, this prompter appears: NO DISPLAY TO RECALL.
- **F3=**
- **F4=**
- **F5=OVERWRITE**—Initiates an overwrite operation. When you attempt to write, load, reconstitute, or exception-build an entity, if that entity already exists in the destination, a prompter appears that asks if you want to overwrite it.
- **F6=**
- **F7=RECON**—Requests that the entity that is identified by the data ENTERED in the first few ports on the first page of the current PED (the ports that identify the entity) be reconstituted. This executes a Reconstitute command without calling up the Reconstitute Command display. While this function works with data points, it is intended for use with reserved entities, where it lets you reconstitute without having to remember or to look up the entity name.

Continued on next page

3.2 Generic Function Keys, Continued

Definition,
continued

- **F8=PED STATUS**—Requests the status display for the current PED set. If no PED exists, this prompter appears: NO PARAM. ENTRY DISPLAY STATUS TO RECALL.
 - **F9=WALK BACK**—If a display other than a menu display is on the screen, this recalls the last menu display. If a menu is on the screen, this key recalls the preceding menu, if any. If a Parameter Entry Display is on the screen, and returning to a menu could cause data to be lost, this prompter appears: WARNING! PED MODIFIED - REPEAT LAST KEYSTROKE TO IGNORE WARNING.
 - **F10=WRITE**—Initiates a Write to IDF command. This executes a write to the last IDF indicated in the IDF pathname in the last Write to IDF command display, without the need to call up the command display. Thus, if you have updated information in a PED, you can write it to the IDF while the PED is still on the screen.
 - **F11=**
 - **F12=LOAD**—Requests that the entity in the current PED set be loaded in the appropriate module or gateway. If the data entered in the PED isn't complete, the Load command is not executed and this prompter appears: PED NOT ENTERED. If the module or gateway the entity is to be loaded in is not operating, the prompter appears: ERR: NODE UNAVAILABLE, COULD NOT ESTABLISH ENTITY ON NET.
-

3.3 Function Keys

Definition

For Releases 400, 410, and 420 the uses of the function keys, other than the generic function keys, are as follows (for functions on the front edge of a key, first press and hold one of the two CTL keys):

- **HOME**—Moves the cursor to the upper left corner of the screen (line 1, character **position 1**).
- **TAB** (up, left, down, right)—These keys move the cursor to the upper left corner of the next pick or port in the direction indicated.
- **CUR** (up, left, down, right)—When one of the CTL keys is held, the TAB keys become cursor movement keys. The cursor moves from character position-to-character position in the direction indicated. Combinations of up and down or left and right moves the cursor diagonally across the screen.
- **PAGE FWD, PAGE BACK**—These keys are used to page through displays that have multiple pages. If there is no next page or preceding page, one of the following prompters appears: NO FORWARD DISPLAY or NO BACKWARD DISPLAY.
- **DISP (FWD, BACK)**—If one of the CTL keys is held, the PAGE FWD and PAGE BACK keys become DISP FWD and DISP BACK keys, in which case they request the next or preceding display in the PED set. If there is no next or preceding display, one of the following prompters appears: NO FORWARD DISPLAY or NO BACKWARD DISPLAY.
- **CLR-ENT**—Clears all values in the port that the cursor is in. If the cursor isn't in a port, the station "beeps."
- **CANCEL**—Clears help information, PED Set Status or a Command Display, from the screen. If no such displays are on the screen, the following prompter appears: NOTHING TO CANCEL.
- **ESC**—Escape to Utilities. Call up the Command Processor display, through which the file manager utilities and text editor can be used. To return to the DEB display, hold CTL and press HELP.
- **CENT**—Puts the line the cursor is on at the center of the screen. When the last full screen of a PED is displayed, and a few lines are left over on the next screen image, pressing CTL and CENT makes the partial screen join with the bottom of the last full screen, pushing an equal number of lines off the top. This is an easy way for you to see the last few lines in the context of the lines that precede them.
- **HELP**—Requests the display of help information for the pick or the port the cursor is in. If there is an error in the data in the port or an error has been made in selecting a pick, up to two additional lines of error information appear in the prompt region. To return to the PED, press CANCEL. If the cursor is not in a pick or a port, the following prompter appears: CURSOR NOT IN PORT OR PICK.

Continued on next page

3.3 Function Keys, Continued

Definition, continued

- **ENTER** (with a PED on the screen)—Requests that the data and selections in the PED set be processed and checked. If the cursor is in a port and no error is found, the cursor is tabbed to the next pick or port. If the cursor is not in a port, it is tabbed to the next pick or port. Should there be no selections or data, the following prompter appears:
NOTHING TO ENTER.
- **ENTER** (with a Command Display on the screen)—Requests that the command be executed. If the command uses or will destroy parameter entry data not yet ENTERed, the following prompter appears:
WARNING! PED MODIFIED - WRITE OR LOAD. REPEAT LAST KEYSTROKE TO IGNORE WARNING. If ENTER is pressed again, the command is unconditionally executed.
- **BREAK**—Requests that execution of the current command be terminated. If an entity or multiple entities are being processed, execution stops after the present entity is processed. This key can also be used to stop the printing of data requested by one of the print commands. Operates only during multiple entity operations and when "WAIT" or "PROCESSING ENTITY" is in the prompter region.
- **COMND**—Requests the Command Display.
- **PRT SCN**—Requests that the present screen image be copied and printed on a Matrix Printer. The printer must be connected to this Universal Station. This function doesn't print transitory images.
- **MENU**—Requests the Engineering Personality's Main Menu. If data or selections have been entered but not yet filed or loaded, the following prompter appears: WARNING! DATA MODIFIED - WRITE OR LOAD. REPEAT LAST KEYSTROKE TO IGNORE WARNING.
- **SELECT**—Selects the pick the cursor is in. This duplicates touching a target (pick) with the touch screen option. An unselected pick has a green or yellow outline. When it is selected, it fills in with light green with white or light blue letters showing through. Picks on menus do not fill-in when selected.

Definitions

For Releases 430 (and later) the uses of some of the function keys were changed as follows (for functions on the front edge of a key, first press and hold one of the two CTL keys):

- **HOME**—Moves the cursor to the upper left corner of the screen (line 1, character **position 2**).
- **TAB** (up, left, down, right)—When one of the CTL keys is held, the TAB keys become cursor movement keys. The cursor moves from character position-to-character position in the direction indicated.
- **CUR** (up, left, down, right)—These keys move the cursor to the upper left corner of the next pick or port in the direction indicated.

Section 4 – Roving Engineer's Keyboard

4.1 Overview

Section contents These are the topics covered in this section:

Topic		See Page
SECTION 4 – ROVING ENGINEER'S KEYBOARD.....		33
4.1	Overview.....	33
4.2	Generic Function Keys.....	34
4.3	Function Keys	36
4.4	Programmable Function Keys PF1–PF17.....	38
4.5	Configuring Keypress Buttons.....	40

Usage

The Floating Engineer's Keyboard is plugged into the connector on the gooseneck support for the keyboard tray. It can be moved from station-to-station without shutting off power. It has short legs mounted under the back corners that will tilt the keyboard for easier usage.

4.2 Generic Function Keys

Designation

Figure 4-1 Roving Engineer's Keyboard Key Designations

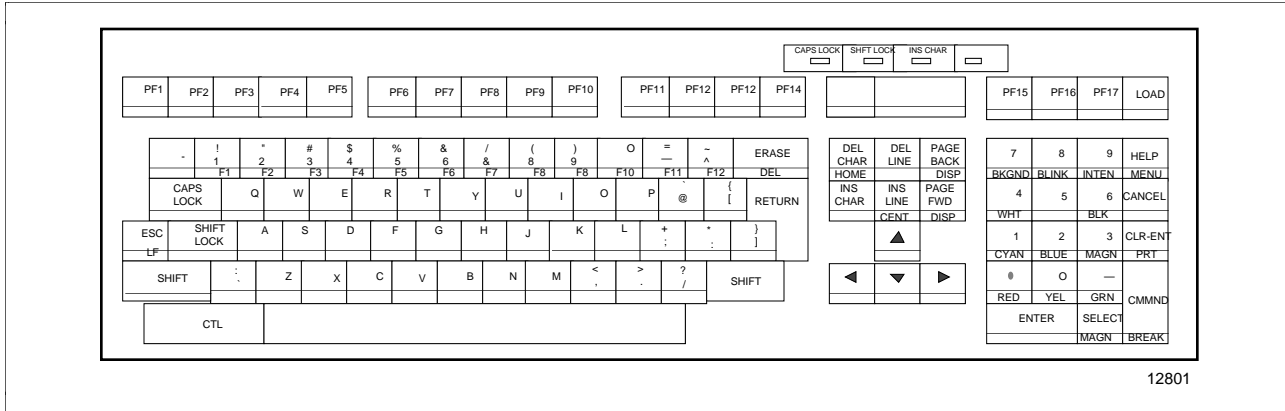

Definition

Note that F1 through F12 are on dual function keys and to get one of the generic functions, CTL must be held down while the key is pressed.

The function of each of these keys is as follows:

- **F1=PED**—Recalls the last Parameter Entry Display (PED). If no PED has been on the screen in this session, this prompter appears:
WARNING: NO PARAM. ENTRY DISPLAY TO RECALL.
- **F2=Recall Disp**—Recalls last support display (a PED help display, a display generated by a display command, or an error file display). If there is no such display to recall, this prompter appears: NO DISPLAY TO RECALL.

Continued on next page

4.2 Generic Function Keys, Continued

Definition,
continued

- **F3=**
 - **F4=**
 - **F5=OVERWRITE**—Initiates an overwrite operation. When you attempt to write, load, reconstitute, or exception-build an entity, if that entity already exists in the destination, a prompter appears that asks if you want to overwrite it.
 - **F6=**
 - **F7=RECON**—Requests that the entity that is identified by the data ENTERed in the first few ports on the first page of the current PED (the ports that identify the entity) be reconstituted. This executes a Reconstitute command without calling up the Reconstitute Command display. While this function works with data points, it is intended for use with reserved entities, where it lets you reconstitute without having to remember or to look up the entity name.
 - **F8=PED STATUS**—Requests the status display for the current PED set. If no PED exists, this prompter appears: NO PARAM. ENTRY DISPLAY STATUS TO RECALL.
 - **F9=WALK BACK**—If a display other than a menu display is on the screen, this recalls the last menu display. If a menu is on the screen, this key recalls the preceding menu, if any. If a Parameter Entry Display is on the screen, and returning to a menu could cause data to be lost, this prompter appears: WARNING! PED MODIFIED - REPEAT LAST KEYSTROKE TO IGNORE WARNING.
 - **F10=WRITE**—Initiates a Write to IDF command. This executes a write to the last IDF indicated in the IDF pathname in the last Write to IDF command display, without the need to call up the command display. Thus, if you have updated information in a PED, you can write it to the IDF while the PED is still on the screen.
 - **F11=**
 - **F12=LOAD**—Requests that the entity in the current PED set be loaded in the appropriate module or gateway. If the data entered in the PED isn't complete, the Load command is not executed and this prompter appears: PED NOT ENTERED. If the module or gateway the entity is to be loaded in is not operating, the prompter appears: ERR: NODE UNAVAILABLE, COULD NOT ESTABLISH ENTITY ON NET.
-

4.3 Function Keys

Definition

For Releases 400, 410, and 420 the uses of the function keys, other than the generic function keys, are as follows (for functions on the front edge of a key, first press and hold one of the two CTL keys):

- **HOME**—Moves the cursor to the upper left corner of the screen (line 1, character position 1).
- **TAB** (up, left, down, right)—These keys move the cursor to the upper left corner of the next pick or port in the direction indicated.
- **CUR** (up, left, down, right)—When one of the CTL keys is held, the TAB keys become cursor movement keys. The cursor moves from character position to character position in the direction indicated. Combinations of up and down or left and right moves the cursor diagonally across the screen .
- **PAGE FWD, PAGE BACK**—These keys are used to page through displays that have multiple pages. If there is no next page or preceding page, one of the following prompters appears: NO FORWARD DISPLAY or NO BACKWARD DISPLAY.
- **DISP (FWD, BACK)** —If one of the CTL keys is held, the PAGE FWD and PAGE BACK keys become DISP FWD and DISP BACK keys, in which case they request the next or preceding display in the PED set. If there is no next or preceding display, one of the following prompters appears: NO FORWARD DISPLAY or NO BACKWARD DISPLAY.
- **CLR-ENT**—Clears all values in the port that the cursor is in. If the cursor isn't in a port, the station "beeps."
- **CANCEL**—Clears help information, PED Set Status or a Command Display, from the screen. If no such displays are on the screen, the following prompter appears: NOTHING TO CANCEL.
- **ESC**—Escape to Utilities. Call up the Command Processor display, through which the file manager utilities and text editor can be used. To return to the DEB display, hold CTL and press HELP.
- **CENT**—Puts the line the cursor is on at the center of the screen. When the last full screen of a PED is displayed, and a few lines are left over on the next screen image, pressing CTL and CENT makes the partial screen join with the bottom of the last full screen, pushing an equal number of lines off the top. This is an easy way for you to see the last few lines in the context of the lines that precede them.
- **HELP**—Requests the display of help information for the pick or the port the cursor is in. If there is an error in the data in the port or an error has been made in selecting a pick, up to two additional lines of error information appear in the prompt region. To return to the PED, press CANCEL. If the cursor is not in a pick or a port, the following prompter appears: CURSOR NOT IN PORT OR PICK.

Continued on next page

4.3 Function Keys, Continued

Definition, continued

- **ENTER** (with a PED on the screen)—Requests that the data and selections in the PED set be processed and checked. If the cursor is in a port and no error is found, the cursor is tabbed to the next pick or port. If the cursor is not in a port, it is tabbed to the next pick or port. Should there be no selections or data, the following prompter appears:
NOTHING TO ENTER.
- **ENTER** (with a Command Display on the screen)—Requests that the command be executed. If the command uses or will destroy parameter entry data not yet ENTERed, the following prompter appears:
WARNING! PED MODIFIED - WRITE OR LOAD. REPEAT LAST KEYSTROKE TO IGNORE WARNING. If ENTER is pressed again, the command is unconditionally executed.
- **BREAK**—Requests that execution of the current command be terminated. If an entity or multiple entities are being processed, execution stops after the present entity is processed. This key can also be used to stop the printing of data requested by one of the print commands. Operates only during multiple entity operations and when "WAIT" or "PROCESSING ENTITY" is in the prompter region.
- **COMND**—Requests the Command Display.
- **PRT SCN**—Requests that the present screen image be copied and printed on a Matrix Printer. The printer must be connected to this Universal Station. This function doesn't print transitory images.
- **MENU**—Requests the Engineering Personality's Main Menu. If data or selections have been entered but not yet filed or loaded, the following prompter appears: WARNING! DATA MODIFIED - WRITE OR LOAD. REPEAT LAST KEYSTROKE TO IGNORE WARNING.
- **SELECT**—Selects the pick the cursor is in. This duplicates touching a target (pick) with the touch screen option. An unselected pick has a green or yellow outline. When it is selected, it fills in with light green with white or light blue letters showing through. Picks on menus do not fill-in when selected.

Definitions

For Releases 430 (and later) the uses of the some of the function keys were changed as follows (for functions on the front edge of a key, first press and hold one of the two CTL keys):

- **HOME**—Moves the cursor to the upper left corner of the screen (line 1, character **position 2**).
- **TAB** (up, left, down, right)—When one of the CTL keys is held, the TAB keys become cursor movement keys. The cursor moves from character position-to-character position in the direction indicated.
- **CUR** (up, left, down, right)—These keys move the cursor to the upper left corner of the next pick or port in the direction indicated.

4.4 Programmable Function Keys PF1–PF17

Button configuration

This keyboard has 17 programmable function keys. You can configure them just as you can on the Operator's Keyboard to call up displays or to initiate other actions and functions. There is virtually no difference in the button configuration on a Roving Engineer's Keyboard. You can configure buttons on either keyboard to emulate a key switch in the Operator Personality.

There are no LEDs in the configurable buttons on the Roving Engineer's Keyboard, therefore, any entry in the LED UNIT field of the *Button Configuration Form, SW88-570*, is meaningless.

The pathname for your button-configuration object file must be entered in the pathname catalog in the area database that the UWS uses when running the Operator Personality.

Configuring PF1–PF17

To allow the Engineer's Keyboard to be used with the Operator Personality, each of the PF1 through PF17 programmable keys can be configured to emulate a configurable button or a function key (SYST STATS, CONS STATS, MAN, AUTO, NORM, SP, OUT, etc.) on the Supervisor's Keyboard or Operator's Keyboard on the US.

PF1 through PF17 behave as if they were 51 programmable keys. This is because there are these possible functions for each key:

- when the key alone is pressed
- when SHIFT is held and the key is pressed
- when CTL is held and the key is pressed

There is no OPER/SUPVR/ENG key switch on the Engineer's Keyboard. In the Operator Personality, if you need to change the key-switch access level for the UWS, you must configure one, two, or three of these keys to do so.

PF1 through PF17 are configured through the BUTTON CONFIGURATION activity on the Engineering Main Menu. Figure 4-2 shows the button configuration display that is used to select one of these keys for configuration. To call up this display, select BUTTON CONFIGURATION on the Engineering Main Menu, and when the first page of configurable buttons appears, press PAGE FWD.

Continued on next page

4.4 Programmable Function Keys PF1–PF17, Continued

Illustration

Figure 4-2 Button Configuration Display for PF1–PF17

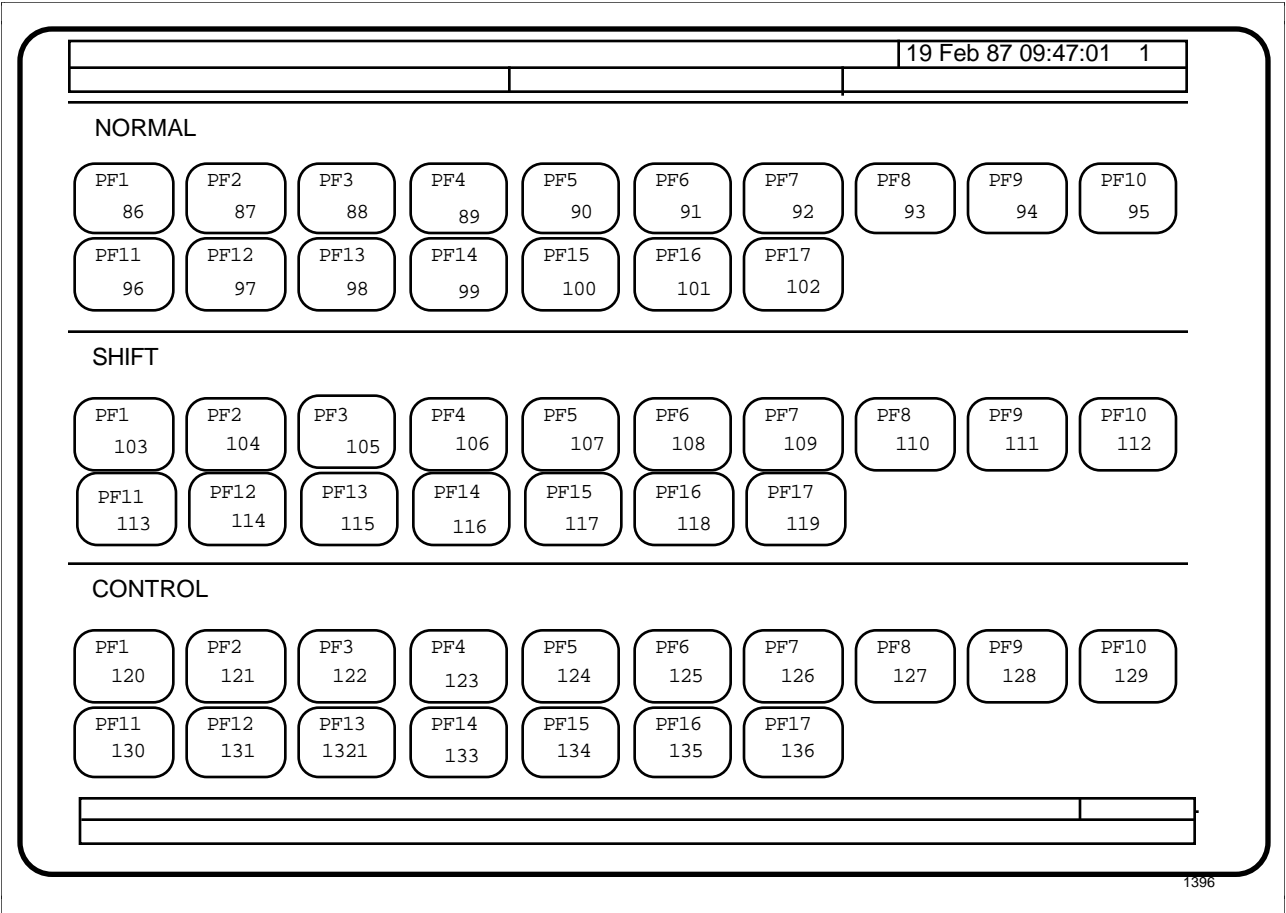

1396

4.5 Configuring Keyswitch Buttons

Configure button

There is no OPER/SUPVR/ENG keyswitch on the Supervisor's Keyboard, but you can configure one, two, or three of the configurable buttons for that function. When started in the Operator Personality, the UWS is at the operator access level. A button must be configured for each keyswitch level you intend to use. If you need to change to all three levels, you must configure three buttons—one to select the supervisor access level, one to select the engineer access level, and one to go back to the operator access level.

Figure 4-3 shows the button configuration display that is used to specify button actions. To call up this display, select **BUTTON CONFIGURATION** on the Engineering Main Menu, then select any button on the first two button selection pages.

Figure 4-3 Button Configuration Display for Specifying Key Actions

19 Feb 87 09:49:38 1

USER CONFIGURABLE BUTTON 49 ROW 6 COLUMN 3

ACTION

QUE_KEY(KEY_ENG)

Enter Button Specifications

1397

Section 5 – U^XS Auxiliary Keyboard

5.1 Overview

Section contents These are the topics covered in this section:

Topic		See Page
SECTION 5 – U^XS AUXILIARY KEYBOARD		41
5.1	Overview.....	41
5.2	Generic function Keys.....	42
5.3	Function Keys	44
5.4	Programmable Function Keys PF1–PF17.....	46
5.5	Configuring Keypress Buttons.....	48

Usage

The U^XS Auxiliary Keyboard is plugged into the connector on the gooseneck support for the keyboard tray. It can be moved from station-to-station without shutting off power. It has short legs mounted under the back corners that will tilt the keyboard for easier usage.

5.2 Generic function Keys

Designation

Figure 5-1 U^XS Auxiliary Keyboard Key Designations

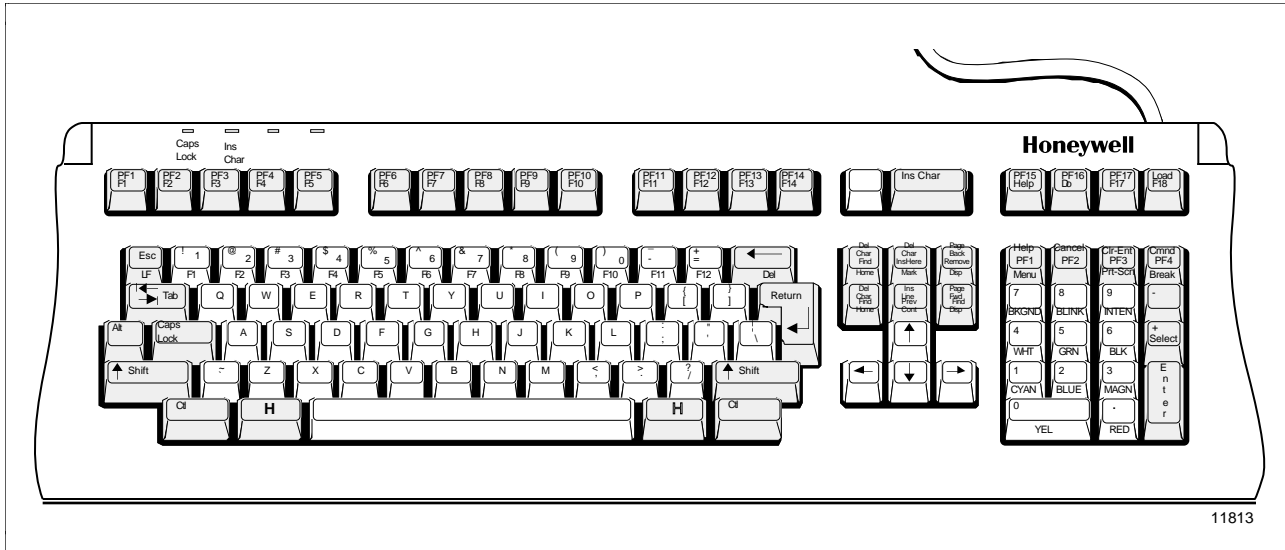

11813

Definition

Note that PF1 through PF12 are on dual function keys and to get one of the generic functions, CTL must be held down while the key is pressed.

The function of each of these keys is as follows:

- **F1=PED**—Recalls the last Parameter Entry Display (PED). If no PED has been on the screen in this session, this prompter appears:
WARNING: NO PARAM. ENTRY DISPLAY TO RECALL.
- **F2=Recall Disp**—Recalls last support display (a PED help display, a display generated by a display command, or an error file display). If there is no such display to recall, this prompter appears: NO DISPLAY TO RECALL.

Continued on next page

5.2 Generic Function Keys, Continued

Definition, continued

- **F4=**
 - **F5=OVERWRITE**—Initiates an overwrite operation. When you attempt to write, load, reconstitute, or exception-build an entity, if that entity already exists in the destination, a prompter appears that asks if you want to overwrite it.
 - **F6=**
 - **F7=RECON**—Requests that the entity that is identified by the data ENTERed in the first few ports on the first page of the current PED (the ports that identify the entity) be reconstituted. This executes a Reconstitute command without calling up the Reconstitute Command display. While this function works with data points, it is intended for use with reserved entities, where it lets you reconstitute without having to remember or to look up the entity name.
 - **F8=PED STATUS**—Requests the status display for the current PED set. If no PED exists, this prompter appears: NO PARAM. ENTRY DISPLAY STATUS TO RECALL.
 - **F9=WALK BACK**—If a display other than a menu display is on the screen, this recalls the last menu display. If a menu is on the screen, this key recalls the preceding menu, if any. If a Parameter Entry Display is on the screen, and returning to a menu could cause data to be lost, this prompter appears: WARNING! PED MODIFIED - REPEAT LAST KEYSTROKE TO IGNORE WARNING.
 - **F10=WRITE**—Initiates a Write to IDF command. This executes a write to the last IDF indicated in the IDF pathname in the last Write to IDF command display, without the need to call up the command display. Thus, if you have updated information in a PED, you can write it to the IDF while the PED is still on the screen.
 - **F11=**
 - **F12=LOAD**—Requests that the entity in the current PED set be loaded in the appropriate module or gateway. If the data entered in the PED isn't complete, the Load command is not executed and this prompter appears: PED NOT ENTERED. If the module or gateway the entity is to be loaded in is not operating, the prompter appears: ERR: NODE UNAVAILABLE, COULD NOT ESTABLISH ENTITY ON NET.
-

5.3 Function Keys

Definition

For Releases 400, 410, and 420 the uses of the function keys, other than the generic function keys, are as follows (for functions on the front edge of a key, first press and hold one of the two CTL keys):

- **HOME**—Moves the cursor to the upper left corner of the screen (line 1, character position 1).
- **TAB** (up, left, down, right)—These keys move the cursor to the upper left corner of the next pick or port in the direction indicated.
- **Arrow** (up, left, down, right)—When one of the CTL keys is held, the TAB keys become cursor movement keys. The cursor moves from character position-to-character position in the direction indicated. Combinations of up and down or left and right moves the cursor diagonally across the screen.
- **PAGE FWD, PAGE BACK**—These keys are used to page through displays that have multiple pages. If there is no next page or preceding page, one of the following prompters appears: NO FORWARD DISPLAY or NO BACKWARD DISPLAY.
- **DISP (FWD, BACK)**—If one of the CTL keys is held, the PAGE FWD and PAGE BACK keys become DISP FWD and DISP BACK keys, in which case they request the next or preceding display in the PED set. If there is no next or preceding display, one of the following prompters appears: NO FORWARD DISPLAY or NO BACKWARD DISPLAY.
- **CLR-ENT**—Clears all values in the port that the cursor is in. If the cursor isn't in a port, the station "beeps."
- **CANCEL**—Clears help information, PED Set Status or a Command Display, from the screen. If no such displays are on the screen, the following prompter appears: NOTHING TO CANCEL.
- **ESC**—Escape to Utilities. Call up the Command Processor display, through which the file manager utilities and text editor can be used. To return to the DEB display, hold CTL and press HELP.
- **CENT**—Puts the line the cursor is on at the center of the screen. When the last full screen of a PED is displayed, and a few lines are left over on the next screen image, pressing CTL and CENT makes the partial screen join with the bottom of the last full screen, pushing an equal number of lines off the top. This is an easy way for you to see the last few lines in the context of the lines that precede them.
- **HELP**—Requests the display of help information for the pick or the port the cursor is in. If there is an error in the data in the port or an error has been made in selecting a pick, up to two additional lines of error information appear in the prompt region. To return to the PED, press CANCEL. If the cursor is not in a pick or a port, the following prompter appears: CURSOR NOT IN PORT OR PICK.

Continued on next page

5.3 Function Keys, Continued

Definition, continued

- **ENTER** (with a PED on the screen)—Requests that the data and selections in the PED set be processed and checked. If the cursor is in a port and no error is found, the cursor is tabbed to the next pick or port. If the cursor is not in a port, it is tabbed to the next pick or port. Should there be no selections or data, the following prompter appears:
NOTHING TO ENTER.
- **ENTER** (with a Command Display on the screen)—Requests that the command be executed. If the command uses or will destroy parameter entry data not yet ENTERed, the following prompter appears:
WARNING! PED MODIFIED - WRITE OR LOAD. REPEAT LAST KEYSTROKE TO IGNORE WARNING. If ENTER is pressed again, the command is unconditionally executed.
- **BREAK**—Requests that execution of the current command be terminated. If an entity or multiple entities are being processed, execution stops after the present entity is processed. This key can also be used to stop the printing of data requested by one of the print commands. Operates only during multiple entity operations and when "WAIT" or "PROCESSING ENTITY" is in the prompter region.
- **COMND**—Requests the Command Display.
- **PRT SCN**—Requests that the present screen image be copied and printed on a Matrix Printer. The printer must be connected to this Universal Station. This function doesn't print transitory images.
- **MENU**—Requests the Engineering Personality's Main Menu. If data or selections have been entered but not yet filed or loaded, the following prompter appears: WARNING! DATA MODIFIED - WRITE OR LOAD. REPEAT LAST KEYSTROKE TO IGNORE WARNING.
- **SELECT**—Selects the pick the cursor is in. This duplicates touching a target (pick) with the touch screen option. An unselected pick has a green or yellow outline. When it is selected, it fills in with light green with white or light blue letters showing through. Picks on menus do not fill-in when selected.

Definitions

For Releases 430 (and later) the uses of the some of the function keys were changed as follows (for functions on the front edge of a key, first press and hold one of the two CTL keys):

- **HOME**—Moves the cursor to the upper left corner of the screen (line 1, character **position 2**).
- **TAB** (up, left, down, right)—When one of the CTL keys is held, the TAB keys become cursor movement keys. The cursor moves from character position-to-character position in the direction indicated.
- **CUR** (up, left, down, right)—These keys move the cursor to the upper left corner of the next pick or port in the direction indicated.

5.4 Programmable Function Keys PF1–PF17

Button configuration

This keyboard has 17 programmable function keys. You can configure them just as you can on the Operator's Keyboard to call up displays or to initiate other actions and functions. There is virtually no difference in the button configuration on a Roving Engineer's Keyboard. You can configure buttons on either keyboard to emulate a key switch in the Operator Personality.

There are no LEDs in the configurable buttons on the Roving Engineer's Keyboard, therefore, any entry in the LED UNIT field of the *Button Configuration Form, SW88-570*, is meaningless.

The pathname for your button-configuration object file must be entered in the pathname catalog in the area database that the UWS uses when running the Operator Personality.

Configuring PF1–PF17

To allow the Engineer's Keyboard to be used with the Operator Personality, each of the PF1 through PF17 programmable keys can be configured to emulate a configurable button or a function key (SYST STATS, CONS STATS, MAN, AUTO, NORM, SP, OUT, etc.) on the Supervisor's Keyboard or Operator's Keyboard on the US.

PF1 through PF17 behave as if they were 51 programmable keys. This is because there are these possible functions for each key:

- when the key alone is pressed
- when SHIFT is held and the key is pressed
- when CTL is held and the key is pressed

There is no OPER/SUPVR/ENG key switch on the Engineer's Keyboard. In the Operator Personality, if you need to change the key-switch access level for the UWS, you must configure one, two, or three of these keys to do so.

PF1 through PF17 are configured through the BUTTON CONFIGURATION activity on the Engineering Main Menu. Figure 5-2 shows the button configuration display that is used to select one of these keys for configuration. To call up this display, select BUTTON CONFIGURATION on the Engineering Main Menu, and when the first page of configurable buttons appears, press PAGE FWD.

Continued on next page

5.4 Programmable Function Keys PF1–PF17, Continued

Illustration

Figure 5-2 Button Configuration Display for PF1–PF17

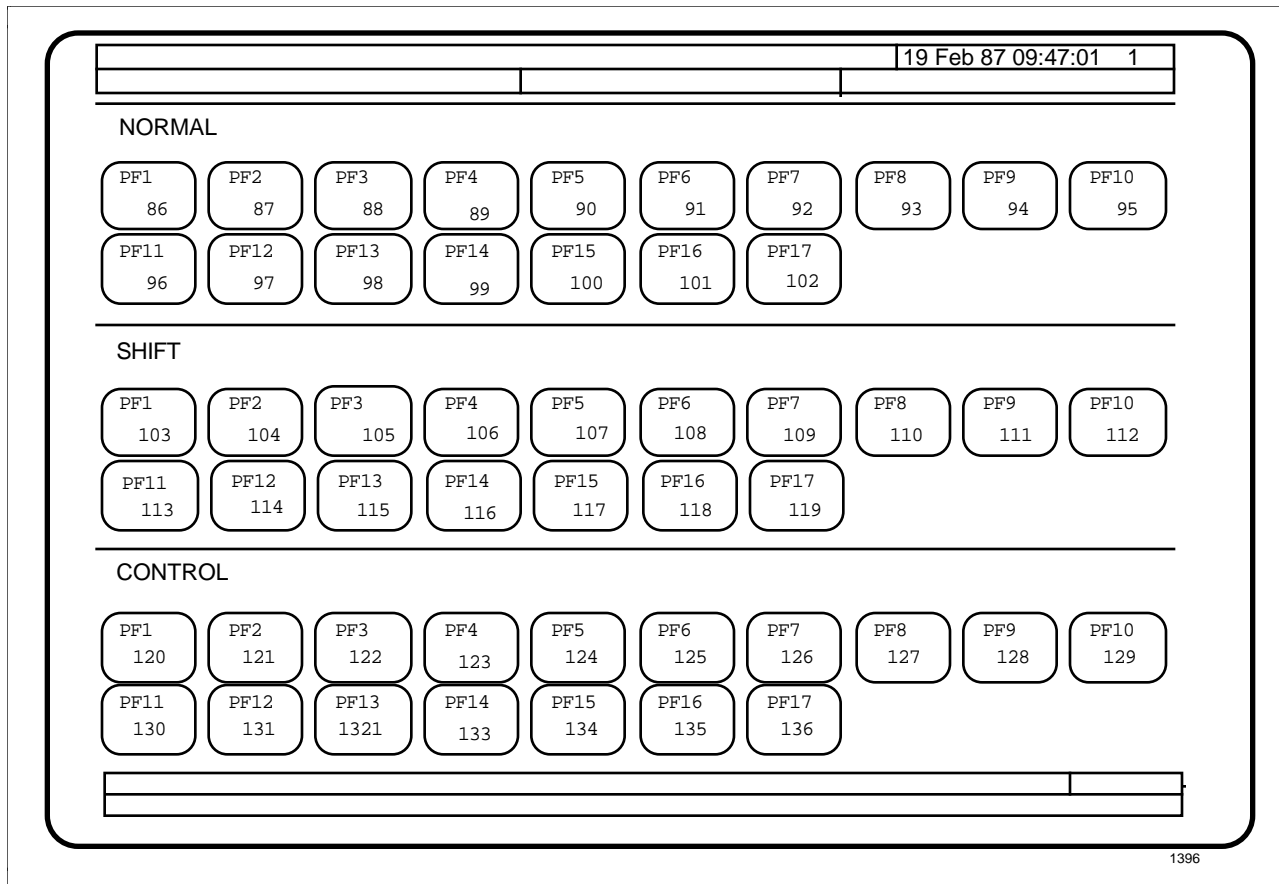

5.5 Configuring Keyswitch Buttons

Configure button

There is no OPER/SUPVR/ENG keyswitch on the Supervisor's Keyboard, but you can configure one, two, or three of the configurable buttons for that function. When started in the Operator Personality, the UWS is at the operator access level. A button must be configured for each keyswitch level you intend to use. If you need to change to all three levels, you must configure three buttons—one to select the supervisor access level, one to select the engineer access level, and one to go back to the operator access level.

Figure 5-3 shows the button configuration display that is used to specify button actions. To call up this display, select **BUTTON CONFIGURATION** on the Engineering Main Menu, then select any button on the first two button selection pages.

Figure 5-3 Button Configuration Display for Specifying Key Actions

19 Feb 87 09:49:38 1

USER CONFIGURABLE BUTTON 49 ROW 6 COLUMN 3

ACTION

QUE_KEY(KEY_ENG)

Enter Button Specifications

1397

Section 6 – U^XS Auxiliary Keyboard in Emulation Mode

6.1 Overview

Section contents These are the topics covered in this section:

	Topic	See Page
SECTION 6 – U^XS AUXILIARY KEYBOARD IN EMULATION MODE.....		49
6.1	Overview.....	49
6.2	Main Function Keys.....	50
6.3	Editing Function Keys.....	52
6.4	Numeric Function Keys.....	53
6.5	Top Row Function Keys.....	54
6.6	Keyboard Mapping in teem-X.....	55

Usage

The U^XS Auxiliary Keyboard is plugged into the connector on the gooseneck support for the keyboard tray. It can be moved from station-to-station without shutting off power. It has short legs mounted under the back corners that will tilt the keyboard for easier usage.

The U^XS uses a LK401 keyboard. This section describes the standard North American version of the LK401 keyboard.

The U^XS Auxiliary Keyboard LK401 has four groups of keys and two indicator lights. The keys are grouped by function:

- Main keypad
- Editing keypad
- Numeric keypad
- Top row function keys

Designation

Figure 6-1 U^XS Auxiliary Keyboard Key Designations

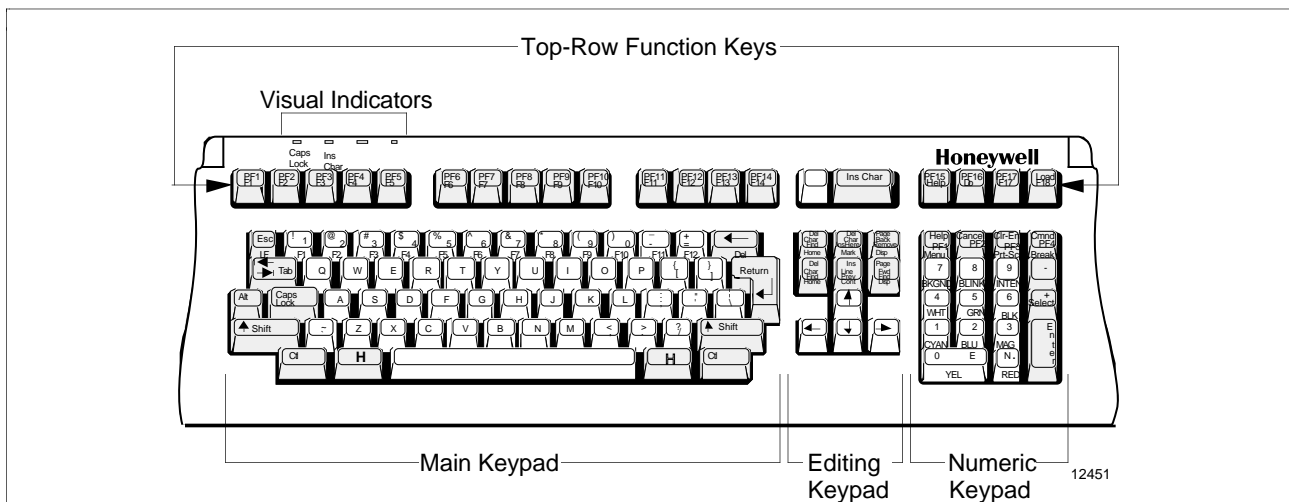

6.2 Main Function Keys

Illustration

Figure 6-2 U^XS Auxiliary Keyboard Main Keypad

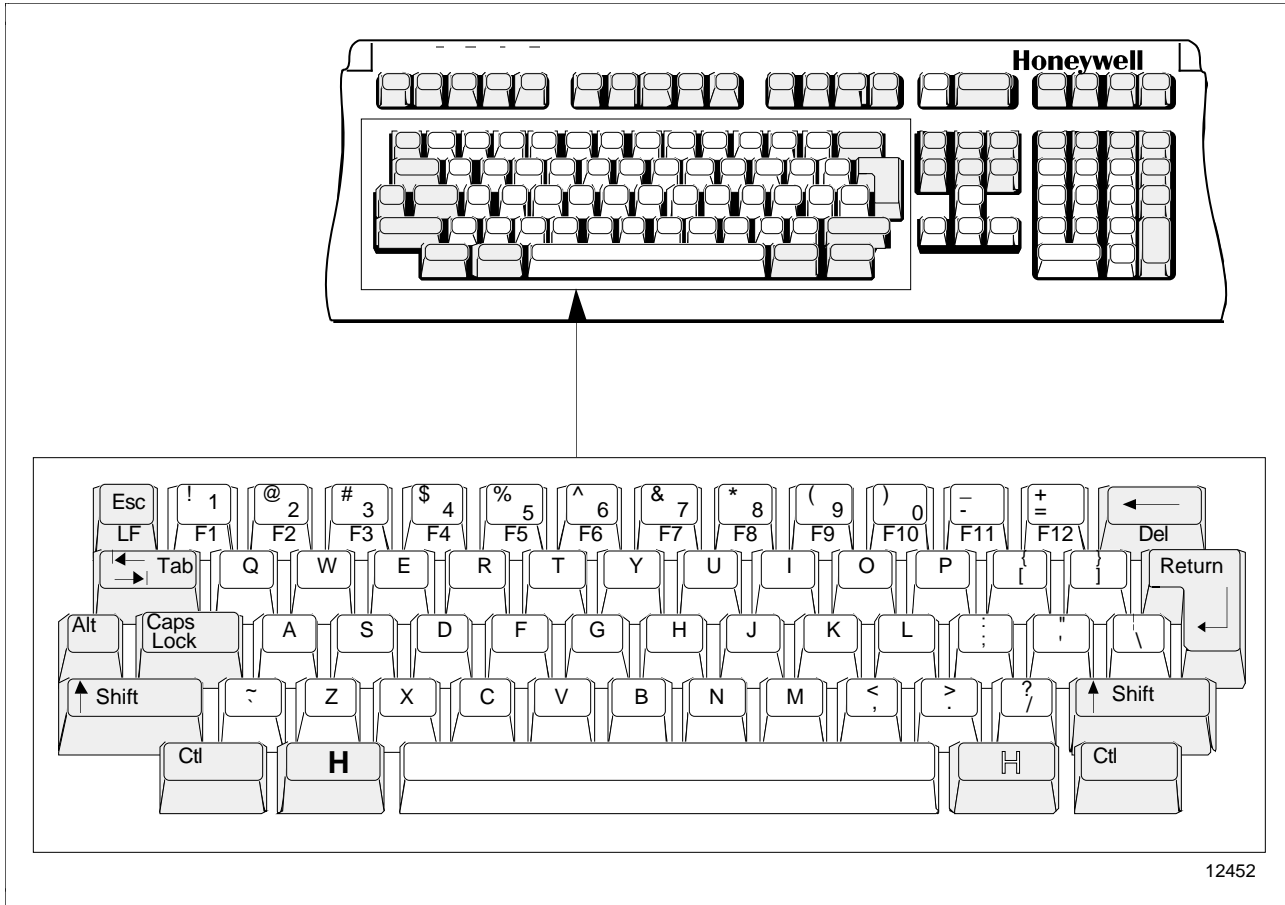

Main keypad

The layout of the main keypad is similar to a typewriter keyboard, with alphanumeric characters, punctuation marks, and SHIFT keys. The Main keypad has the following special function keys.

- **Tab**—The **Tab** key sends a horizontal tab, which normally moves the cursor to the next tab stop on the line.
- **Ctl**—Holding down the **Ctl** key and pressing another key sends a control code to the system. For example, **Ctl-Z** means to hold down the **Ctl** key and press the **Z** key. A control code tells the system to perform a special function.
- **Caps Lock**—Pressing **Caps Lock** down puts the keyboard in **Caps Lock** mode and makes the alphabetic keys send their uppercase characters. You turn **Caps Lock** mode on and off by pressing and releasing the **Caps Lock** key. When the **Caps Lock** is active, the **CAPS** indicator light turns on.

Continued on next page

6.2 Main Function Keys, Continued

Main keypad,
continued

- **Shift**—Holding down **Shift** (left or right) and pressing a standard key on the main keyboard sends the shifted (top) character on the key.
 - **Return**—Pressing **Return** sends either a carriage return or a carriage return and a line feed.
 - **Backarrow/Del**—Pressing the **Backarrow/Del** key normally sends a DEL (delete) character. Many applications use DEL to erase one character to the left of the cursor.
 - **Space bar**—Pressing the **Space bar** sends a SP (space) character. Spaces are used to separate words or move the cursor forward.
-

ATTENTION

ATTENTION—When interacting with VAX-based applications, some keys may need to be remapped in the *X-Teem340* terminal emulator software. For keyboard mapping, refer to *teem-X 320 & 340 Operator's Manual*.

6.3 Editing Function Keys

Illustration

Figure 6-3 U^XS Auxiliary Keyboard Editing Keypad

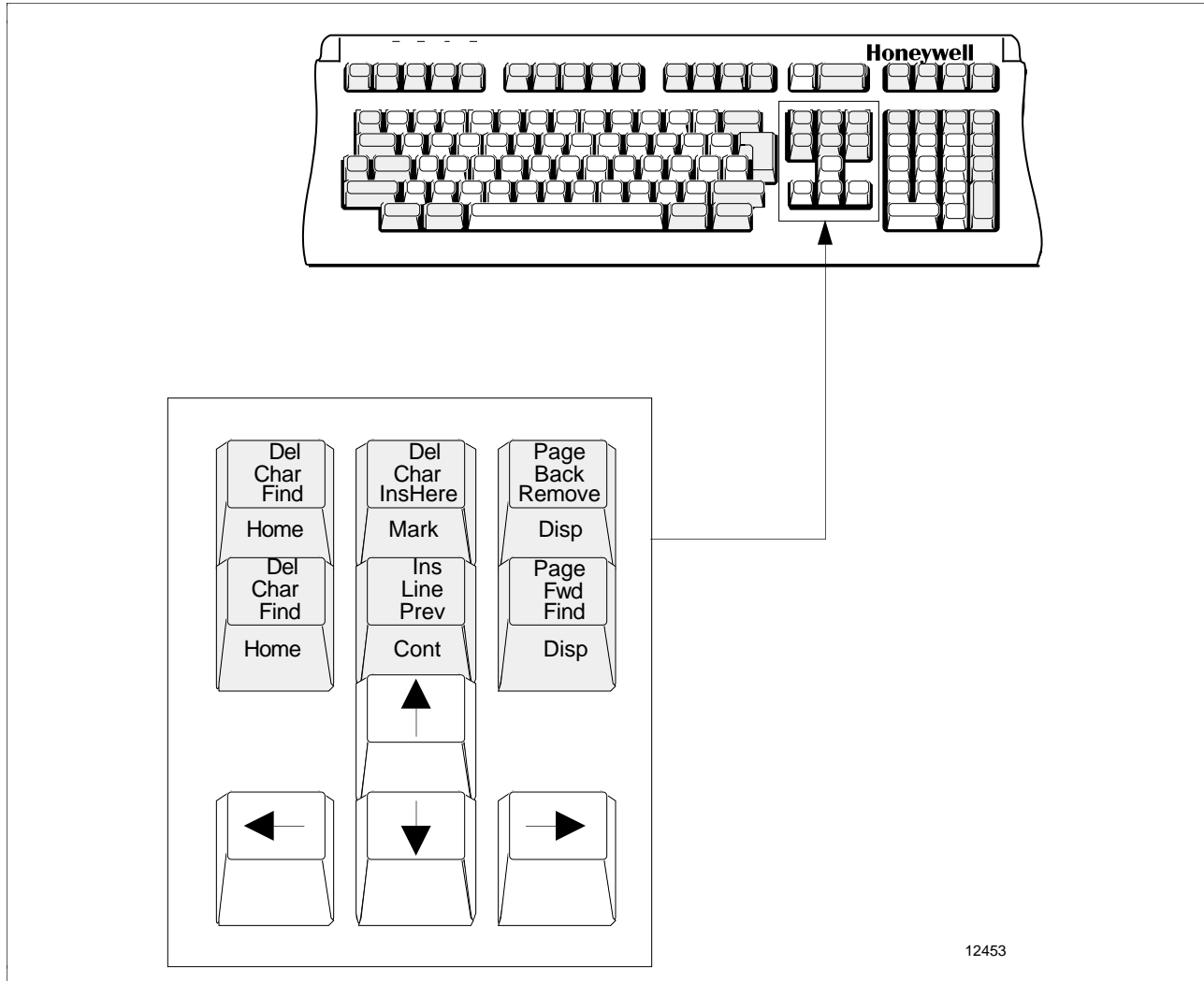

Editing keypad

The editing keypad has four arrow keys and six editing keys.

- **Arrow keys**—Pressing an **Arrow key** normally moves the cursor in the direction of the arrow.

ATTENTION

ATTENTION—When interacting with VAX-based applications, some keys may need to be remapped in the *X-Teem340* terminal emulator software. For keyboard mapping, refer to *teem-X 320 & 340 Operator's Manual*.

6.4 Numeric Function Keys

Illustration

Figure 6-4 U^XS Auxiliary Keyboard Numeric Keypad

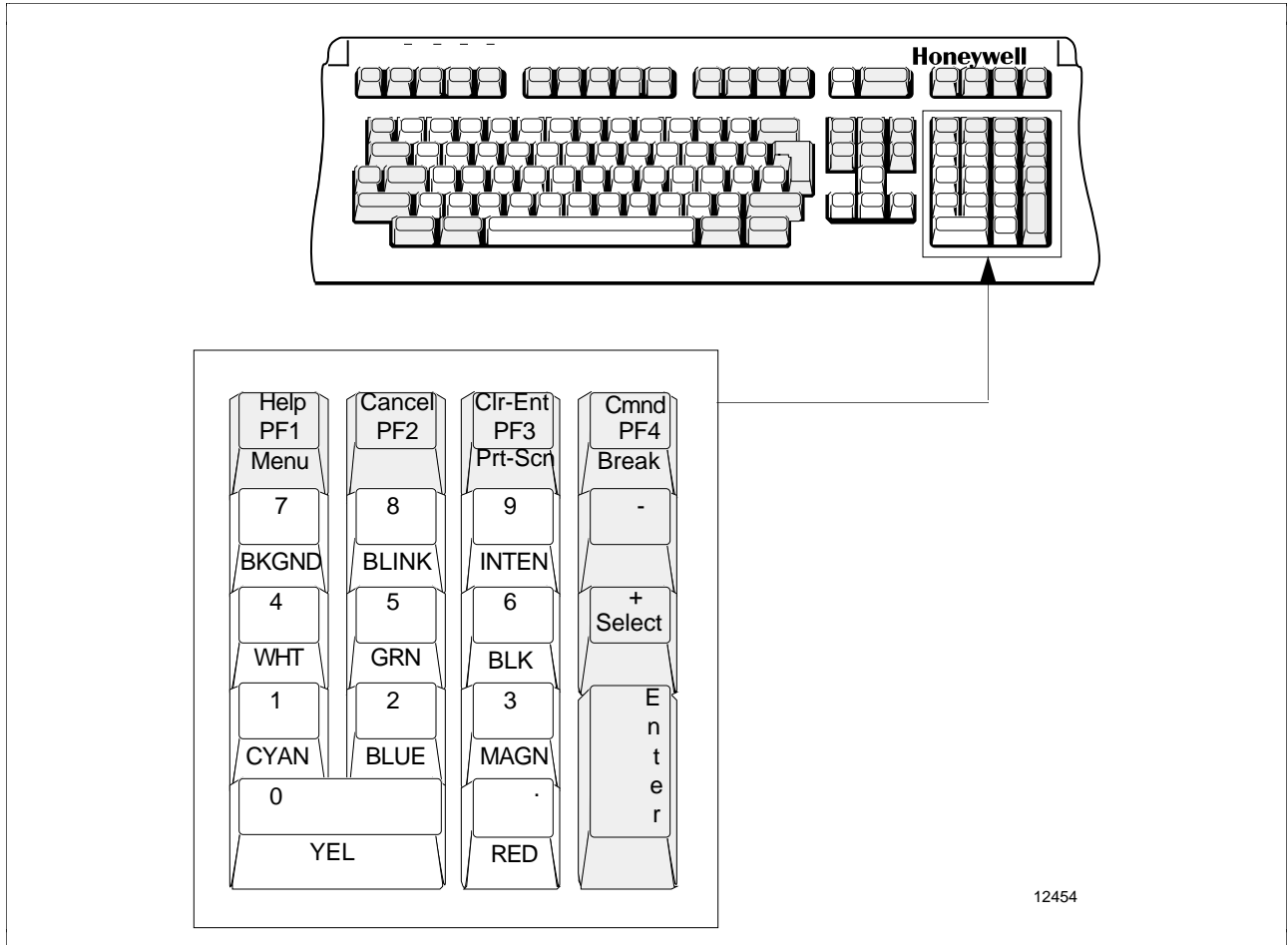

Numeric keypad

Numeric keypad keys often have functions assigned by your application software, especially **PF1**, **PF2**, **PF3**, **PF4**. See your application manuals for details. Some applications let you use the numeric keypad to enter numeric data as you would with a calculator.

- **Enter**—The **Enter** key normally works like the **Return** key. That is, Enter sends a carriage return or a carriage return and line feed.

ATTENTION

ATTENTION—When interacting with VAX-based applications, some keys may need to be remapped in the *X-Teem340* terminal emulator software. For keyboard mapping, refer to *teem-X 320 & 340 Operator's Manual*.

6.5 Top Row Function Keys

Illustration

Figure 6-5 U^XS Auxiliary Keyboard Top Row Keys

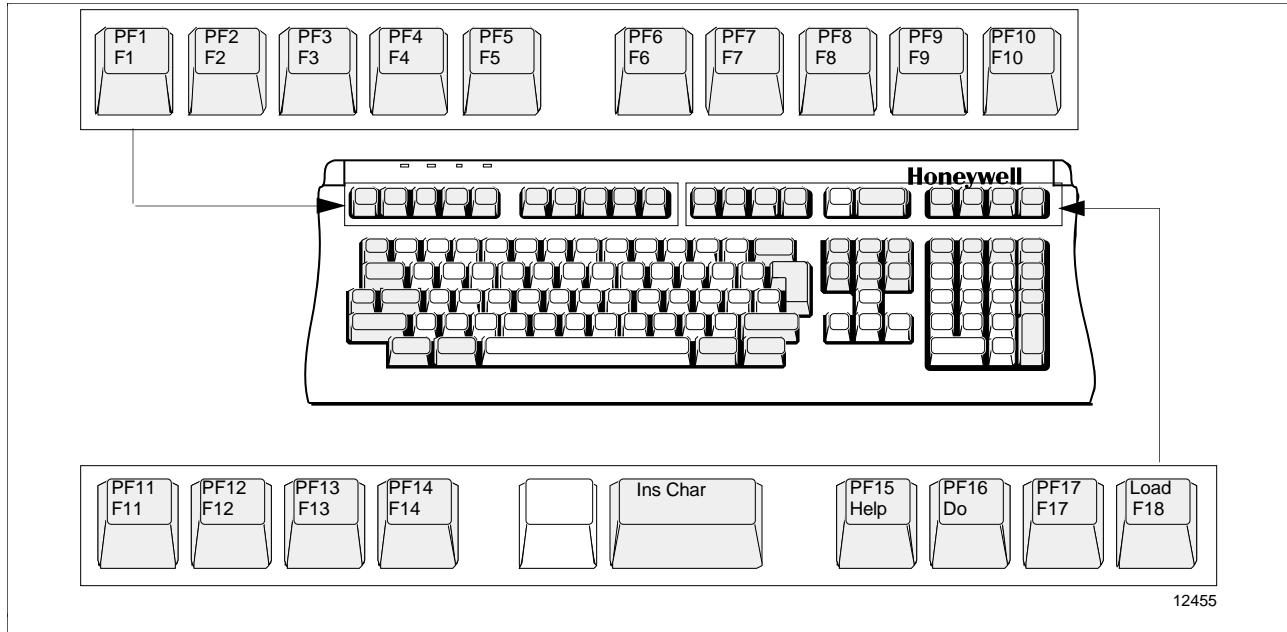

Top row keys

- **F1-F18**—When interacting with VAX-based applications, these keys must be remapped in the *X-Teem340* terminal emulator software.

ATTENTION

ATTENTION—For keyboard mapping, refer to *teem-X 320 & 340 Operator's Manual*.

Due to the necessity for remapping frequently used keys, the user should execute VAX-based applications through the *X-Teem340* terminal emulator.

6.6 Keyboard Mapping in teem-X

Usage

The teem-X is a terminal emulator designed for the X Window System-based workstations. The teem-X maps the keyboard of the DEC VT-300 as near as possible.

Key codes

The following table identifies the corresponding keycodes for VAX systems VT-300 emulation on the U^XS using teem-X terminal emulator.

Table 6-1 Key Codes

U ^X S			VAX System	
Key ID Red/Blue	Key Code	Kana Key Code	Key ID	Key Code
PF1 *4 F1	ffbe F1 not recognized	ffbe F1 not recognized	F1	ffbe F1 ffbe F1
PF2 F2	ffbf F1 ffbf F2	ffbf F2 ffbf F2	F2	ffbf F2 ffbf F2
PF3 F3	ffc0 F3 ffc0 F3	ffc0 F3 ffc0 F3	F3	ffc0 F3 ffc0 F3
PF4 F4	ffc1 F4 ffc1 F4	ffc1 F4 ffc1 F4	F4	ffc1 F4 ffc1 F4
PF5 F5	ffc2 F5 ffc2 F5	ffc2 F5 ffc2 F5	F5	ffc2 F5 ffc2 F5
PF6 F6	ffc3 F6 ffc3 F6	ffc3 F6 ffc3 F6	F6	ffc3 F6 ffc3 F6
PF7 F7	ffc4 F7 ffc4 F7	ffc4 F7 ffc4 F7	F7	ffc4 F7 ffc4 F7
PF8 F8	ffc5 F8 ffc5 F8	ffc5 F8 ffc5 F8	F8	ffc5 F8 ffc5 F8
PF9 F9	ffc6 F9 ffc6 F9	ffc6 F9 ffc6 F9	F9	ffc6 F9 ffc6 F9
PF10 F10	ffc7 F10 ffc7 F10	ffc7 F10 ffc7 F10	F10	ffc7 F10 ffc7 F10
PF11 F11	ffc8 F11 ffc8 F11	ffc8 F11 ffc8 F11	F11	ffc8 F11 ffc8 F11
PF12 F12	ffc9 F12 ffc9 F12	ffc9 F12 ffc9 F12	F12	ffc9 F12 ffc9 F12
PF13 F13	ffca F13 ffca F13	ffca F13 ffca F13	F13	ffca F13 ffca F13
PF14 F14	ffcb F14 ffcb F14	ffcb F14 ffcb F14	F14	ffcb F14 ffcb F14
'blank' *3	ff7e Mode_switch ff7e Mode_switch	ff7e Mode_switch ff7e Mode_switch	Help	ff6a Help ff6a Help
Ins Char	ff63 Insert ff63 Insert	ff63 Insert ff63 Insert	Do	ff67 Menu ff67 Menu

Continued on next page

6.6 Keyboard Mapping in teem-X, Continued

Table 6-1 Key Codes

UXs			VAX System		
Key ID Red/Blue	Key Code	Kana Key Code	Key ID	Key Code	
PF15 *1 Help	ff6a Help ff6a Help	ff6a Help ff6a Help	F17	ffce F17 ffce F17	
PF16 *1 Do	ff67 Menu ff67 Menu	ff67 Menu ff67 Menu	F18	ffcf F18 ffcf F18	
PF17 *1 F17	ffce F17 ffce F17	ffce F17 ffce F17	F19	ffd0 F19 ffd0 F19	
PF18 *1 F18	ffcf F18 ffcf F18	ffcf F18 ffcf F18	F20	ffd1 F20 ffd1 F20	
DelChar Find	ff68 Find ff68 Find	ff68 Find ff68 Find	Find	ff68 Find ff68 Find	
DelLine Ins Here	ff63 Insert ff63 Insert	ff63 Insert ff63 Insert	Insert	ff63 Insert ff63 Insert	
PageBack *1 Remove	ffff Delete ffff Delete	ffff Delete ffff Delete	Remove	ff00 DRemove ff00 DRemove	
'blank' Select	ff60 Select ff60 Select	ff60 Select ff60 Select	Select	ff60 Select ff60 Select	
Ins Line Prev	ff55 Prior ff55 Prior	ff55 Prior ff55 Prior	Prev	ff55 Prior ff55 Prior	
Page Fwd Next	ff56 Next ff56 Next	ff56 Next ff56 Next	Next	ff56 Next ff56 Next	
Left	ff51 Left ff51 Left	ff51 Left ff51 Left	Left	ff51 Left ff51 Left	
Up	ff52 Up ff52 Up	ff52 Up ff52 Up	Up	ff52 Up ff52 Up	
Right	ff53 Right ff53 Right	ff53 Right ff53 Right	Right	ff53 Right ff53 Right	
Down	ff54 Down ff54 Down	ff54 Down ff54 Down	Down	ff54 Down ff54 Down	
Help PF1	ff91 KP_F1 ff91 KP_F1	ff91 KP_F1 ff91 KP_F1	PF1	ff91 KP_F1 ff91 KP_F1	
Cancel PF2	ff92 KP_F2 ff92 KP_F2	ff92 KP_F2 ff92 KP_F2	PF2	ff92 KP_F2 ff92 KP_F2	
Clr-Ent PF3	ff93 KP_F3 ff93 KP_F3	ff93 KP_F3 ff93 KP_F3	PF3	ff93 KP_F3 ff93 KP_F3	
Cmnd PF4	ff94 KP_F4 ff94 KP_F4	ff94 KP_F4 ff94 KP_F4	PF4	ff94 KP_F4 ff94 KP_F4	
7	ffb7 KP_7 ffb7 KP_7	ffb7 KP_7 ffb7 KP_7	7	ffb7 KP_7 ffb7 KP_7	

Continued on next page

6.6 Keyboard Mapping in teem-X, Continued

Table 6-1 Key Codes

UXs			VAX System	
Key ID Red/Blue	Key Code	Kana Key Code	Key ID	Key Code
8	ffb8 KP_8 ffb8 KP_8	ffb8 KP_8 ffb8 KP_8	8	ffb8 KP_8 ffb8 KP_8
9	ffb9 KP_9 ffb9 KP_9	ffb9 KP_9 ffb9 KP_9	9	ffb9 KP_9 ffb9 KP_9
- *1	ffad KP_Subtract ffad KP_Subtract	ffad KP_Subtract ffad KP_Subtract	-	ffad KP_Subtract ffad KP_Subtract
4	ffb4 KP_4 ffb4 KP_4	ffb4 KP_4 ffb4 KP_4	4	ffb4 KP_4 ffb4 KP_4
5	ffb5 KP_5 ffb5 KP_5	ffb5 KP_5 ffb5 KP_5	5	ffb5 KP_5 ffb5 KP_5
6	ffb6 KP_6 ffb6 KP_6	ffb6 KP_6 ffb6 KP_6	6	ffb6 KP_6 ffb6 KP_6
+ *1	ffab KP_Add ffab KP_Add	ffab KP_Add ffab KP_Add	'	ffab KP_Separator ffab KP_Separator
1	ffb2 KP_2 ffb2 KP_2	ffb2 KP_2 ffb2 KP_2	2	ffb2 KP_2 ffb2 KP_2
3	ffb3 KP_3 ffb3 KP_3	ffb3 KP_3 ffb3 KP_3	3	ffb3 KP_3 ffb3 KP_3
0	ffb0 KP_0 ffb0 KP_0	ffb0 KP_0 ffb0 KP_0	0	ffb0 KP_0 ffb0 KP_0
.	ffae KP_Decimal ffae KP_Decimal	ffae KP_Decimal ffae KP_Decimal	.	ffae KP_Decimal ffae KP_Decimal
Enter	ff8d KP_Enter ff8d KP_Enter	ff8d KP_Enter ff8d KP_Enter	Enter	ff8d KP_Enter ff8d KP_Enter
Esc *2	ff1b Escape ff1b Escape	ff1b Escape ff1b Escape	`/~	60 Grave 7e asciitilde
1/!	31 1 21 exclam	4c7 kana_NU 4c7 kana_NU	1/!	31 1 21 exclam
2/@	32 2 40 at	4cc kana_FU 4cc kana_FU	2/@	32 2 40 at
3/#	33 3 23 numbering	4b1 kana_A 4a7 kana_a	3/#	33 3 23 numbering
4/\$	34 4 24 dollar	4b3 kana_U 4a9 kana_u	4/\$	34 4 24 dollar
5/%	35 5 25 percent	4b4 kana_E 4aa kana_e	5/%	35 5 25 percent
6/^	36 6 5e asciicircum	4b5 kana_O 4ab kana_o	6/^	36 6 5e asciicircum

Continued on next page

6.6 Keyboard Mapping in teem-X, Continued

Table 6-1 Key Codes

UXs			VAX System		
Key ID Red/Blue	Key Code	Kana Key Code	Key ID	Key Code	
7/&	37 7 26 ampersand	4d4 kana_YA 4ac kana_ya	7/&	37 7 26 ampersand	
8/*	38 8 2a asterisk	4d5 kana_YU 4ad kana_yu	8/*	38 8 2a asterisk	
9/(39 9 28 parenleft	4d6 kana_YO 4ae kana_yo	9/(39 9 28 parenleft	
0/)	30 0 29 parenright	4dc kana_WA 4a6 kana_WO	0/)	30 0 29 parenright	
-/_	2d minus 5f underscore	4ce kana_HO 4ce kana_HO	-/_	2d minus 5f underscore	
=/+	3d equal 2b plus	4cd kana_HE 4cd kana_HE	=/+	3d equal 2b plus	
<- *1	ff08 KP_6 ff08 KP_6	ffb6 KP_6 ffb6 KP_6	<-x	ffff Delete ffff Delete	
Tab	ff09 Tab ff09 Tab	ff09 Tab ff09 Tab	Tab	ff09 Tab ff09 Tab	
q/Q	71 q 51 Q	4c0 kana_TA 4c0 kana_TA	q/Q	71 q 51 Q	
w/W	77 w 57 W	4c3 kana_TE 4c3 kana_TE	w/W	77 w 57 W	
e/E	65 e 45 E	4c3 kana_TE 4c3 kana_TE	e/E	65 e 45 E	
r/R	72 r 52 R	4bd kana_SU 4bd kana_SU	r/R	72 r 52 R	
t/T	74 t 54 T	4b6 kana_KA 4b6 kana_KA	t/T	74 t 54 T	
y/Y	79 y 59 Y	4dd kana_N 4dd kana_N	y/Y	79 y 59 Y	
u/U	75 u 55 U	4c5 kana_NA 4c5 kana_NA	u/U	75 u 55 U	
i/l	69 i 49 l	4c6 kana_NI 4c6 kana_NI	i/l	69 i 49 l	
o/O	6f o 4f O	4d7 kana_RA 4d7 kana_RA	o/O	6f o 4f O	
p/P	70 p 50 P	4be kana_SE 4be kana_SE	p/P	70 p 50 P	
[/{	5b bracketleft 7b braceleft	4db kana_RO 4de kana_voicedsound	[/{	5b bracketleft 7b braceleft	

Continued on next page

6.6 Keyboard Mapping in teem-X, Continued

Table 6-1 Key Codes

UXs			VAX System		
Key ID Red/Blue	Key Code	Kana Key Code	Key ID	Key Code	
]}	5d bracketright 7d braceright	4d1 kana_MU 4df kana_semivoiced]}	5d bracketright 7d braceright	
Return	ff0d Return ff0d Return	ff0d Return ff0d Return	Return	ff0d Return ff0d Return	
Alt *1	ffe9 Alt_L ffe9 Alt_L	ffe9 Alt_L ffe9 Alt_L	Alt	ffe9 Alt_L ffe9 Alt_L	
Caps Lock	ffe5 Caps_Lock ffe5 Caps_Lock	ffe5 Caps_Lock ffe5 Caps_Lock	Caps Lock	ffe5 Caps_Lock ffe5 Caps_Lock	
a/A	61 a 41 A	4c1 kana_CHI 4c1 kana_CHI	a/A	61 a 41 A	
s/S	73 s 53 S	4c4 kana_TO 4c4 kana_TO	s/S	73 s 53 S	
d/D	64 d 44 D	4bc kana_SHI 4bc kana_SHI	d/D	64 d 44 D	
f/F	66 f 46 F	4ca kana_HA 4ca kana_HA	f/F	66 f 46 F	
g/G	67 g 47 G	4b7 kana_KI 4b7 kana_KI	g/G	67 g 47 G	
h/H	68 h 48 H	4b8 kana_KU 4b8 kana_KU	h/H	68 h 48 H	
j/J	6a j 4a J	4cf kana_MA 4cf kana_MA	j/J	6a j 4a J	
k/K	6b k 4b K	4c9 kana_NO 4c9 kana_NO	k/K	6b k 4b K	
l/L	6c l 4c L	4d8 kana_RI 4d8 kana_RI	l/L	6c l 4c L	
;/:	3b semicolon 3a colon	4da kana_RE 4da kana_RE	;/:	3b semicolon 3a colon	
'/”	27 apostrophe 22 quotedbl	4b9 kana_KE 4b9 kana_KE	'/”	27 apostrophe 22 quotedbl	
V	5c backslash 7c bar	4a2 kana_openbracket 4a3 kana_closedbracket	V	5c backslash 7c bar	
Shift	ffe1 Shift_L ffe1 Shift_L	ffe1 Shift_L ffe1 Shift_L	Shift	ffe1 Shift_L ffe1 Shift_L	
`/~ *2	60 grave 7e asciitilde	4b0 prolongsound 4b0 prolongsound	>/<	3c less 3e greater	
z/Z	7a a 5a Z	4c2 kana_TSU 4af kana_tsu	z/Z	7a a 5a Z	

Continued on next page

6.6 Keyboard Mapping in teem-X, Continued

Table 6-1 Key Codes

uXs			VAX System		
Key ID Red/Blue	Key Code	Kana Key Code	Key ID	Key Code	
x/X	78 x	4bb kana_SA	x/X	78 x	
	58 X	4bb kana_SA		58 X	
c/C	63 c	4bf kana_SO	c/C	63 c	
	43 c	4bf kana_SO		43 c	
v/V	76 v	4cb kana_HI	v/V	76 v	
	56 V	4cb kana_HI		56 V	
b/B	62 b	4ba kana_KO	b/B	62 b	
	42 B	4ba kana_KO		42 B	
n/N	6e n	4d0 kana_MI	n/N	6e n	
	4e N	4d0 kana_MI		4e N	
m/M	6d m	4d3 kana_MO	m/M	6d m	
	4d M	4de kana_MO		4d M	
,/<	2c comma	4c8 kana_NE	,/<	2c comma	
	3c less	4a4 kana_comma		3c less	
./>	2e period	4d9 kana_RU	./>	2e period	
	3e greater	4a1 kana_fullstop		3e greater	
//?	2f slash	4d2 kana_ME	//?	2f slash	
	3f question	4a5 kana_conjunctive		3f question	
Shift	ffe2 Shift_R	ffe2 Shift_R	Shift	ffe2 Shift_R	
	ffe2 Shift_R	ffe2 Shift_R		ffe2 Shift_R	
Ctrl *1	ffe3 Control_L	ffe3 Control_L	Ctrl	ff20 Multi_key	
	ffe3 Control_L	ffe3 Control_L		ff20 Multi_key	
Meta *1	ffe7 Meta_L	ffe7 Meta_L	Meta	ffe9 Alt_L	
	ffe7 Meta_L	ffe7 Meta_L		ffe9 Alt_L	
Space	20 Space	20 Space	Space	20 Space	
	20 Space	20 Space		20 Space	
Meta *1	ffe8 Meta_R	ffe8 Meta_R	Meta	ffe9 Alt_R	
	ffe8 Meta_R	ffe8 Meta_R		ffe9 Alt_R	
Ctrl *1	ffe4 Control_R	ffe4 Control_R	Ctrl	ff20 Multi_key	
	ffe4 Control_R	ffe4 Control_R		ff20 Multi_key	

ATTENTION

- *1. Key remapping required for Xteem-340 emulator
- *2. Key remapping desirable for Xteem-340 emulator, but not practical.
- *3. Kana key is nonfunctional on non-Japanese keyboards.
- *4. Shift F1 does not give a recognizable key code. Caps-Lock F1 work.

Section 7 – Integrated Keyboard

7.1. Overview

Section contents These are the topics covered in this section:

	Topic	See Page
	SECTION 7 – INTEGRATED KEYBOARD	61
7.1.	Overview	61
7.2	Console Mounted Integrated Keyboard.....	62
7.3	Desktop Integrated Keyboards	63
7.4	IKB Functional Partion Description	64
7.5	Full Travel Keyboard.....	65
7.6	Relegendable Function Key Panel.....	68
7.7	Operator Control Panel.....	69

Scope

The Integrated Keyboard (IKB) has the functionality of the Operator Keyboard and Engineer keyboard integrated into a single keyboard that has two forms—Console and deskside.

- Consol mount—mounts on the new console furniture
- Deskside—Mounts on classic console furniture
- Deskside—rests on a table or desktop as a part of a Micro TDC 3000 and Universal Work Station

Programmable buttons

There are a total of 133 buttons and keys on the IKB that can be configured for 121 programmable functions.

- 79 buttons on the Relegendable Function Key Panel (RFKP)
- 17 keys (P1-P17) using the control key
- 17 keys (PF1-PF17) using the Shift key
- 14 keys (PF1-P14) without using the shift or control key
- 6 keys located on the Operators Control Panel

7.2 Console Mounted Integrated Keyboard

Description

The console mounted version of the IKB mounts on the new furniture Universal Station and Universal Station^X units. The configurable button panel tilts forward giving access to the removable media drives.

There is an optional trackball integrated in IKB surface as show below.

Figure 7-1 Integrated Keyboard with Trackball



7.3 Desktop Integrated Keyboards

Description

Desktop IKBs have a fixed configurable button panel and the optional trackball and are designed to be:

- placed on the flat surface of a desk or table
- placed on the keyboard pedistile of a classic furniture Universal Station or Universal Station^X.

Figure 7-2 Desktop Integrated Keyboard

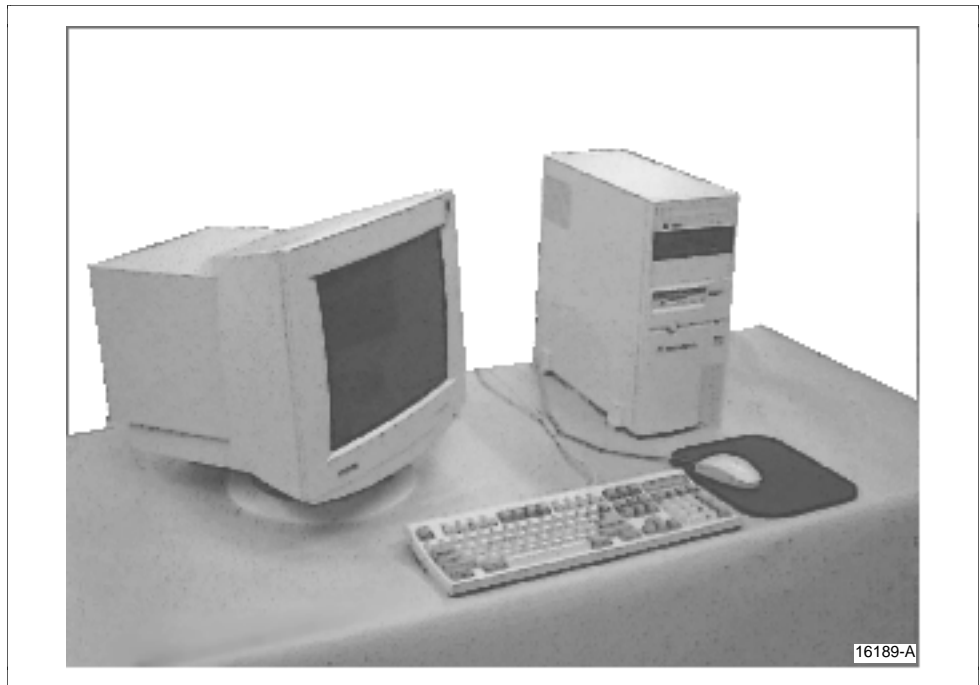

7.4 IKB Functional Partion Description

Overview

The integrated keyboard integrates the operator and engineer function into one keyboard and has the following functional parts:

- Full Travel Keyboard
 - Relegendable Function Key Panel
 - Operator Control Panel
 - Optional Cursor Control Unit (Trackball)
-

7.5 Full Travel Keyboard

Description

This QUERTY keyboard function as both operator and engineer's keyboard with multifunctional keys labeled in black, red, and blue lettering like the UXS Auxiliary keyboard.

Figure 7-3 Full Travel Keyboard

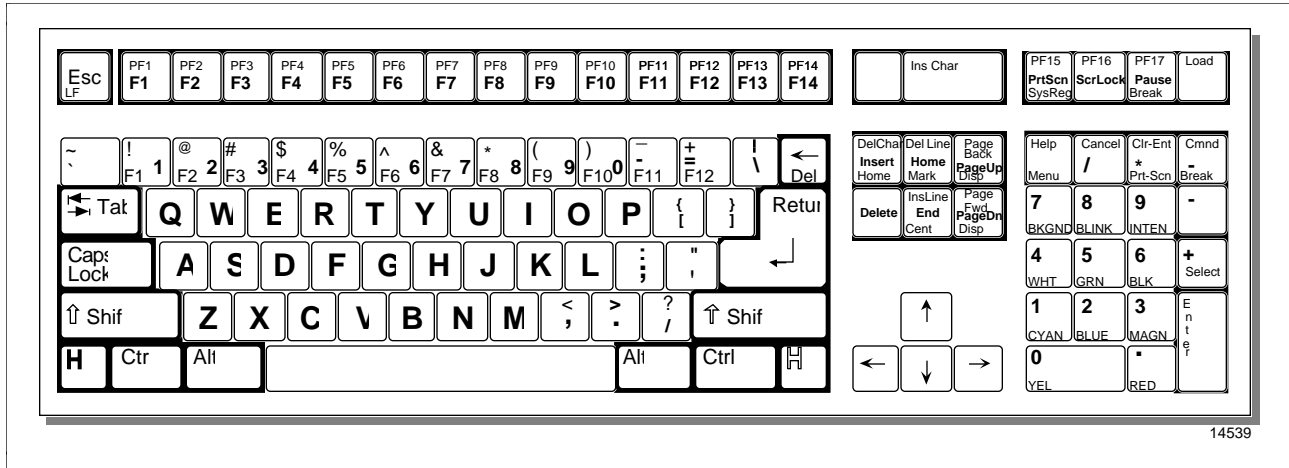

F1-F14 (blue lettering)

Across the top of the full travel keyboard are keys labeled in blue F1-F14. These keys are predetermined function keys in the Data Entity Building mode. Note that F1 through F14 are on dual-function keys and to get one of the generic functions, CTL must be held down while the key is pressed.

In the Data Entity Building function of each of these keys is as follows:

- **F1=PED**—Recalls the last Parameter Entry Display (PED). If no PED has been on the screen in this session, this prompter appears:
WARNING: NO PARAM. ENTRY DISPLAY TO RECALL.
- **F2=Recall Disp**—Recalls last support display (a PED help display, a display generated by a display command, or an error file display). If there is no such display to recall, this prompter appears: NO DISPLAY TO RECALL.
- **3=**
- **F4=**
- **F5=OVERWRITE**—Initiates an overwrite operation. When you attempt to write, load, reconstitute, or exception-build an entity, if that entity already exists in the destination, a prompter appears that asks if you want to overwrite it.
- **F6=**

Continued on next page

7.5 Full Travel Keyboard, Continued

- **F7=RECON**—Requests that the entity that is identified by the data ENTERed in the first few ports on the first page of the current PED (the ports that identify the entity) be reconstituted. This executes a Reconstitute command without calling up the Reconstitute Command display. While this function works with data points, it is intended for use with reserved entities, where it lets you reconstitute without having to remember or to look up the entity name.
 - **F8=PED STATUS**—Requests the status display for the current PED set. If no PED exists, this prompter appears: NO PARAM. ENTRY DISPLAY STATUS TO RECALL.
 - **F9=WALK BACK**—If a display other than a menu display is on the screen, this recalls the last menu display. If a menu is on the screen, this key recalls the preceding menu, if any. If a Parameter Entry Display is on the screen, and returning to a menu could cause data to be lost, this prompter appears: WARNING! PED MODIFIED - REPEAT LAST KEYSTROKE TO IGNORE WARNING.
 - **F10=WRITE**—Initiates a Write to IDF command. This executes a write to the last IDF indicated in the IDF pathname in the last Write to IDF command display, without the need to call up the command display. Thus, if you have updated information in a PED, you can write it to the IDF while the PED is still on the screen.
 - **F11=**
 - **F12=LOAD**—Requests that the entity in the current PED set be loaded in the appropriate module or gateway. If the data entered in the PED isn't complete, the Load command is not executed and this prompter appears: PED NOT ENTERED. If the module or gateway the entity is to be loaded in is not operating, the prompter appears: ERR: NODE UNAVAILABLE, COULD NOT ESTABLISH ENTITY ON NET.
 - **F13=**
 - **F14=**
-

Continued on next page

7.5 Full Travel Keyboard, Continued

PF1-PF17 (red lettering)

To allow the Engineer's Keyboard to be used with the Operator Personality, each of the PF1 through PF17 programmable keys can be configured to emulate a configurable button or a function key (SYST STATS, CONS STATS, MAN, AUTO, NORM, SP, OUT, etc.) on the Supervisor's Keyboard or Operator's Keyboard on the US.

PF1 through PF17 behave as if they were 48 programmable keys. This is because there are these possible functions for each key:

- when the key alone is pressed (only keys PF1-PF14)
- when SHIFT is held and the key is pressed
- when CTL is held and the key is pressed

PF1 through PF17 are configured through the BUTTON CONFIGURATION activity on the Engineering Main Menu. Figure 4-2 shows the button configuration display that is used to select one of these keys for configuration. To call up this display, select BUTTON CONFIGURATION on the Engineering Main Menu and when the first page of configurable buttons appears, press PAGE FWD.

7.6 Relegendable Function Key Panel

Description

Relegendable function keys (buttons) can be defined or configured by the user to perform certain functions, such as the callup of certain critical or frequently used displays, or cross-screen displays within a console, or to activate a particular Control language program. Refer to *Button Configuration Form Instructions* and *Button Configuration Data Entry* for button configuration. Refer to Sections 7 and 8 of the *Process Operation Manual* for Alarm Annunciation.

This panel has two forms:

- Fixed—Desktop units have a fixed panel
- Hinged—new furniture Universal Station and Universal Station^X units have a hinged panel that tilts away from the monitor, revealing the 150 MB cartridge drive, DAT drive and CD ROM drive. After the drive has been loaded the panel can be returned to the upright position.

Figure 7-4 Relegendable Function Key Panel

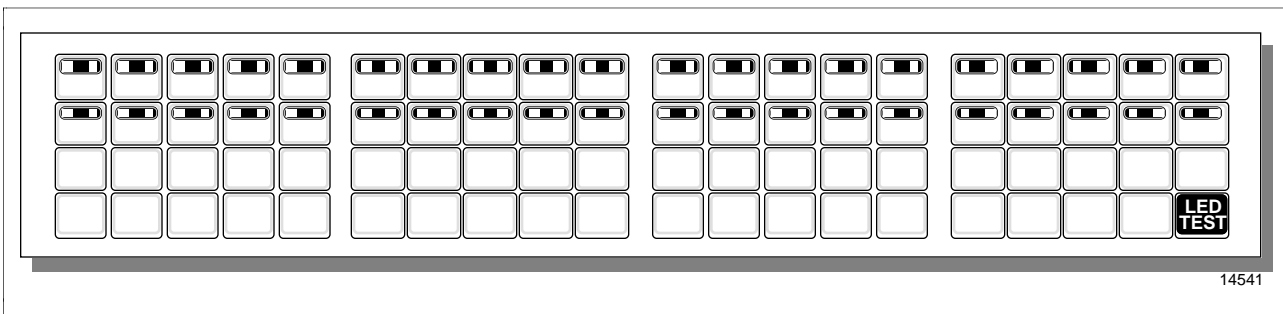

7.7 Operator Control Panel

Description

Figure 7-5 Operator's Control Panel

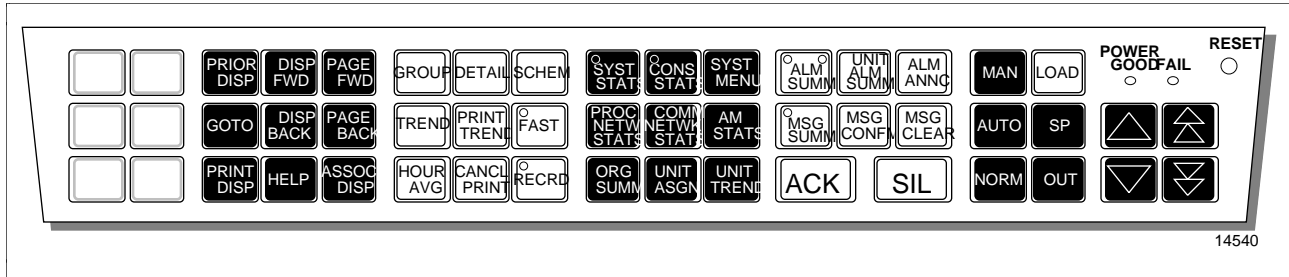

Reset

Resets the Universal Station hardware; does the same thing as the white reset button on any LCN Module.

Power Good

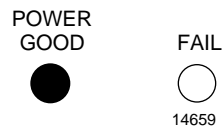

The indicator is lit if all power supplies are operating within their correct voltage ranges.

Fail Indicator

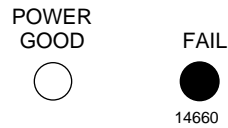

The FAIL indicator is lit if there is a hardware failure in the Universal Station.

Configurable buttons



These six buttons are relegendable function keys

Continued on next page

7.7 Operator Control Panel, Continued

Illustration

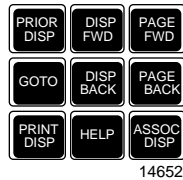

PRIOR DISP

Prior Display key—Calls up the display that was shown immediately before the current display. If pressed while viewing a Group Trend Display, it cancels the Group Trend Display and returns to the Group Display.

DISP FWD

Display Forward key—Calls up the next higher-numbered display within the same type of display as the current display. As an example, the Display Forward key is used when going from Group Display 5 to Group Display 6.

PAGE FWD

Display Forward key—Calls up the next higher-numbered display within the same type of display as the current display. As an example, the Display Forward key is used to go from Group Display 5 to Group Display 6.

GO TO

Go To key—Used to select a point on the Group Display; requires entry of the desired Point Number, 1–8.

DISP BACK

Display Back key—Calls up the next lower-numbered display within the same type of display as the current display. For example, if Group Display 250 is on the screen and DISP BACK is pressed, Group Display 249 is called up.

PAGE BACK

Page Back key—Calls up the next lower-numbered page of a multiple page display.

PRINT DISP

Print Display Key—The display currently on the screen is printed on the stations assigned printer.

HELP

Help key—Calls up a preconfigured operator Help display associated with the current display. The Help display could take the form of a prompt, a maintenance suggestion, or a reference to a related display for additional information.

ASSOC DISP

Associated Display key—Calls up the configured display associated with an item chosen from the current display.

Continued on next page

7.7 Operator Control Panel, Continued

Illustration

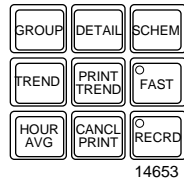

GROUP	Group display key—Calls up the Group Display; requires entry of a Group Number.
DETAIL	Detail display key—Calls up the detail display; requires entry of a Tagname (Point ID).
SCHEM	Schematic key—Calls up a graphic Schematic Display; requires entry of a Schematic name.
TREND	Trend key—Calls up the Group Trend Display from the Operating Group Display by selecting a point to be trended and pressing the Trend key.
PRINT TREND	Print Trend key—Activates trend printing for a selected point. Trends for all points in an operating group can be printed on the Matrix Printer.
FAST	Fast update key—(1) Causes the update rate for hiway-related display information to increase to 2-second intervals instead of the standard update rate of once every 4 seconds. An example is to press the FAST key while viewing a group display. (2) Can cause certain parameters in Graphic (Custom) Displays to update twice a second, if so configured.
HOUR AVG	Hourly Averages key—Calls up the Hourly Averages Display from the Operating Group Display.
CANCL PRINT	Cancel Print key—Used to abort any currently printing output on any printer in the console. When pressed, the prompt asks the operator to enter the console-related printer number. Cancel Print does not function across stations with different personalities.
RECRD	Trend Pen Record key—Activates trend-pen recording of a selected point. Trend pen recording is activated from the Operating Group Display by pressing the RECRD key. This key is backlit while recording is in progress. Pressing the key a second time terminates the recording operation.

Continued on next page

7.7 Operator Control Panel, Continued

Illustration

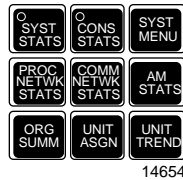

SYST STAT	System Status key—Calls up the System Status Display. Key backlight blinks when there is an unacknowledged system alarm and is steady when alarm(s) is ACKnowledged.
CONS STAT	Console Status key—Calls up the Console Status and Assignments Display. Key backlight blinks when there is an unacknowledged console alarm and is steady when alarm(s) is ACKnowledged.
SYST MENU	System Menu key—Calls up the System Menu Display X.
PROC NETW K STATS	Process Networks Node Status—Calls up the Process Networks Node Status Display
COMM NETWK STATS	Communications Networks Status—Calls up the Communications Networks Status Display
AM STATS	AM Status—Calls up the Application Modules Node Status Display
ORG SUMM	Organizational Summary—Calls up the Organizational Summary Menu
UNIT ASGN	Unit Assignment—Calls up the Unit Assignment Display
UNIT TREND	Unit Trend key—Calls up the Unit Trend Display; requires entry of a Unit ID.

Continued on next page

7.7 Operator Control Panel, Continued

Illustration

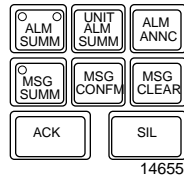

ALM SUMM

Alarm Summary key—Calls up the Area Alarm Summary Display. The Alarm Summary key lights whenever an Alarm Event is received by the Universal Station, and remains lit as long as alarms exist in the area. There are two backlights, red and yellow, that indicate the Priority and Acknowledgment state of the alarms; refer to Sections 7 and 8 of the *Process Operation Manual* for details.

UNIT ALM SUMM

Unit Alarm Summary key—Calls up the Unit Alarm Summary Display; requires entry of a Unit ID.

ALM ANNC

Alarm Annunciator display key—Calls up the Alarm Annunciator Display.

MSG SUMM

Message Summary key—Calls up the Message Summary Display. The key is backlit and blinks whenever there are messages that require operator acknowledgment. The key is lit steadily whenever all messages have been acknowledged, but messages exist that require operator confirmation.

MSG CONFM

Message Confirmation key—This key is associated with the Message Summary Display. Messages are acknowledged and/or confirmed (if necessary) from this display. Position the cursor to any message desired on the display (using Fast Raise/Lower keys) and press the Message Confirmation Key to confirm the message. Confirmation is message-by-message.

MSG CLEAR

Message Clear key—This key is used to clear messages that have been acknowledged and confirmed on the Message Summary Display. Clearing is page-by-page.

ACK

Alarm Acknowledge key—Acknowledges all Process Alarms or System Status Alarms for the console; must be used when an Alarm or System Status Display is on-screen. Silences the Audible Alarm, if it has not already been silenced.

SIL

Silence key—Silences all audible alarms in the console.

Continued on next page

7.7 Operator Control Panel, Continued

Illustration



MAN

Manual mode key—Places a selected point in manual mode; that is, the output is under direct control of the operator.

LOAD

LOAD key—initiates loading of the node personality.

AUTO

Automatic mode key—Places a selected point in automatic mode if configured for that mode. In automatic mode, the output (OP) value is calculated by a preconfigured algorithm using an operator-entered setpoint (SP).

SP

Setpoint key—Permits changes to be made to setpoint values for a point. Pressing the Setpoint key allows changes of setpoint values to be entered either by the numeric keys, or by the Raise/Lower keys.

NORM

Normal mode key—Places the selected point in its NORMally configured mode.

OUT

Output key—Permits changes of Analog or Digital Output values. After the key is pressed (for example, while viewing a Detail Display), the Output value can be changed by a keyboard entry or by the Raise/Lower keys.

Continued on next page

7.7 Operator Control Panel, Continued

Illustration

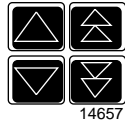

Digital state change or slow raise/lower

These two keys perform two functions. They serve as Digital State Change keys and slow-speed Raise/Lower functions.

Digital State Change—While viewing a Digital or Flag Point display, the up-arrow key can be configured to indicate an ON or OFF state of a Digital Output point. The down-arrow is configured for the opposite state. To change a Latch-type Digital Output state, the tagname must be selected, the Upper or Lower State Change key must be pressed, and the ENTER key must be pressed to complete the operation. Momentary-type Digital State selection does not require the ENTER key to complete the operation.

The Slow Raise/Lower operation allows the operator to increase or decrease a selected value or parameter shown on a display. When one of the single-arrow keys is tapped (pressed, then immediately released), the least-significant digit of the parameter is incremented or decremented by one. When the key is held down, the parameter is incremented/decremented by one percent of the full-scale range every 2/3 seconds.

Fast raise/lower

Fast Raise/Lower keys—Pressing the double up-arrow key causes the parameter to be increased at the configured fast rate, and pressing the double down-arrow key causes the parameter to be decreased at the configured fast rate. When either of the keys is held down, the parameter is increased/decreased every 2/3 of a second by the configured fast raise/lower rate.

The fast raise/lower rate is configured to change at the rate of 2, 3, 5, or 10 percent of the parameter's full-scale range and is configured on a system basis.

Index

A

Alarm Acknowledge 21
Alarm Annunciator 22
Alarm Function Section 21
Alarm Summary 22
Alphabetic Operator's Keyboard 4
Arrow 44
Associated Display 18
Auto 23

B

Batch 17
Bottom Three Rows of Buttons 13
BREAK 32, 37, 45
Button configuration 38, 46
Button Configuration Display for PF1–PF17 39, 47
Button Configuration Display for Specifying Key
Actions 40, 48

C

CANCEL 31, 36, 44
Cancel Print 15
CENT 31, 36, 44
Clear Entry 26
CLR-ENT 31, 36, 44
COMND 32, 37, 45
Configuring PF1–PF17 38, 46
Console Status 14
CUR 31, 36

D

Detail 16
Digital State Change or Slow Raise/Lower 25
DISP (FWD, BACK) 31, 36, 44
Display Back 18
Display Forward 18
Display Set 17

E

Engineer's Keyboard (fixed mounting) 1
Engineer's Keyboards (roving) 1
ENTER 32, 37, 45
ESC 31, 36, 44

F

F1 29, 34, 42, 65
F10 30, 35, 43, 66
F11 30, 35, 43, 66

F12 30, 35, 43, 66
F13 66
F14 66
F2 29, 34, 42
F2.i. 65
F3 29, 35
F3.i. 65
F4 29, 35, 43, 65
F5 29, 43, 65
F6 29, 35, 43, 65
F7 29, 35, 43, 66
F8 30, 35, 43, 66
F9 30, 35, 43, 66
Fail Indicator 13, 69
Fast 14
Fast Raise/Lower 25
Fixed Engineer's Keyboard 2, 6, 27, 28
Function keys 27

G

Generic Function Key Designations 29
Go To 17
Group 16

H

Help 17, 31, 36, 44
HOME 31, 32, 36, 37, 44, 45
Hourly Average 18

I, J

IKB 61
Integrated Keyboard 61
Buttons 61
Console Mount 62
Desktop Mount 63
F1-F12 Description 65
Full Travel Keyboard 65
Functional Description 64
Operator Panel 69
Configureable buttons 69
Programmable Function Keys PF1-PF17 67
Relegendable Keys 68
Relegendable Key Panel 68

K

Key Codes 55, 56, 57, 58, 59, 60
Key marking 27
keyboard mapping 51, 52, 53, 54

Index

L

LK401 keyboard 49
Load 15, 30, 35, 43, 66

M

Manual Mode 23
MENU 32, 37, 45
Message Clear 22
Message Confirm 22
Message Summary 21

N

Normal Mode 24

O

Operator Control Keys 23
Operator Keyboard — Numeric Keypad 20
Operator's Keyboard 1, 11
Operator's Keyboard (QWERTY) 1
Operator's Keyboard Description 11
Original Operator's Keyboard 3
Output 24
OVERWRITE 29, 43, 65

P

Page Back 19
Page Forward 19
PAGE FWD, PAGE BACK 31, 36, 44
PED 29, 34, 42, 65
PED STATUS 30, 35, 43, 66
Power Good 13, 69
Print Display 15
Print Trend 15
Prior Display 18
Programmable Function Keys PF1–PF17 38, 46
PRT SCN 32, 37, 45

Q

QWERTY Operator's Keyboard 5

R

Recall Disp 29, 34, 42, 65
RECON 29, 35, 43, 66
Reset 13, 69

Reset Switch and Power Indicators 13
Roving Engineer's Keyboard 33
Roving Engineer's Keyboard 2, 7
Roving Engineer's Keyboard Key Designations 34

S

Schematic 17
Section contents *1, 11, 27, 33, 41, 49, 61*
Select 26, 32, 37, 45
Setpoint 24
Silence 21
Standard Keys — Left Column 16
Standard Numeric Keys 20
Standard Numeric Touchpad 20
Standard Section — Second Row 14
System Menu 15
System Status 14

T

TAB 32, 36, 44
Tab Keys 26
teem-X 320 & 340 Operator's Manual. 51, 52, 53, 54
Trend 17
Trend Pen Record 14

U, V

Unit Alarm Summary 22
Unit Trend 16
U^XS Auxiliary Keyboard 8, 41, 49
U^XS Auxiliary Keyboard (roving) 1
U^XS Auxiliary Keyboard Editing Keypad 52
U^XS Auxiliary Keyboard in Emulation Mode 49
U^XS Auxiliary Keyboard Key Designations 49
U^XS Auxiliary Keyboard Main Keypad 50
U^XS Auxiliary Keyboard Numeric Keypad 53
U^XS Auxiliary Keyboard Top Row Keys 54

W

WALK BACK 30, 35, 43, 66
WRITE 30, 35, 43, 66

X, Y, Z

X-Teem340 51, 52, 53, 54
• TAB 31

READER COMMENTS

Honeywell's IAC Automation College welcomes your comments and suggestions to improve future editions of this and other publications.

You can communicate your thoughts to us by fax, mail, or toll-free telephone call. We would like to acknowledge your comments; please include your complete name and address.

BY FAX: Use this form; and fax to us at (602) 313-4108

BY TELEPHONE: In the U.S.A. use our toll-free number 1*800-822-7673 (available in the 48 contiguous states except Arizona; in Arizona dial 1-602-313-5558).

BY MAIL: Use this form; detach, fold, tape closed, and mail to us.

Title of Publication: **Keyboards**

Issue Date: **2/96**

Publication Number: **SW09-508**

Writer: **David Downey**

COMMENTS : _____

RECOMMENDATIONS : _____

NAME : _____ **DATE :** _____

TITLE : _____

COMPANY : _____

ADDRESS : _____

CITY : _____ **STATE :** _____ **ZIP :** _____

TELEPHONE : _____ **FAX :** _____

(If returning by mail, please tape closed; Postal regulations prohibit use of staples.)

Communications concerning technical publications should be directed to:

Automation College
Industrial Automation and Control
Honeywell Inc.
2820 West Kelton Lane
Phoenix, Arizona 85023

FOLD

FOLD

From: _____



NO POSTAGE
NECESSARY
IF MAILED
IN THE USA

BUSINESS REPLY MAIL
FIRST CLASS PERMIT NO. 4332 PHOENIX, ARIZONA

POSTAGE WILL BE PAID BY

Honeywell

Industrial Automation and Control
2820 West Kelton Lane
Phoenix, Arizona 85023

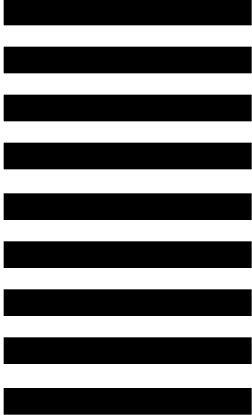

Cut Along Line

Attention: Manager, Quality

FOLD

FOLD

Additional Comments:

Honeywell

Industrial Automation and Control
Honeywell Inc.
16404 North Black Canyon Highway
Phoenix, Arizona 85023-3033

Helping You Control Your World