

Implementation Overview

SW09-560

**Implementation
Startup & Reconfiguration - 1**

***Implementation
Overview***

**SW09-560
Release 500
8/95**

Copyright, Trademarks, and Notices

Printed in U.S.A. — © Copyright 1995 by Honeywell Inc.

Revision 01 – August 1, 1995

While this information is presented in good faith and believed to be accurate, Honeywell disclaims the implied warranties of merchantability and fitness for a particular purpose and makes no express warranties except as may be stated in its written agreement with and for its customer.

In no event is Honeywell liable to anyone for any indirect, special or consequential damages. The information and specifications in this document are subject to change without notice.

About This Publication

This publication provides an overview of the complete implementation process for LCN-based TDC 3000^X systems. These are the primary objectives of this publication:

- To provide a preview for users who are implementing a new system and to provide a quick review for users who are reconfiguring part of an existing system.
- To indicate dependencies, so that you can do the planning, design, and data entry in an order that minimizes back tracking and reconfiguration.

The information in this publication is for guidance only. It does not prescribe a rigorous procedure for system implementation. In real situations, there is almost always some overlap between activities, and it is often necessary to go from one activity to an earlier one, to do additional work or to correct earlier work.

This publication supports TDC 3000^X software Release 500.

Change bars are used to indicate paragraphs, tables, or illustrations containing changes that have been made by Document Change Notices or an update. Pages revised only to correct minor typographical errors contain no change bars. All changes made by previous Document Change Notices have been incorporated in this update.

Table of Contents

1 INTRODUCTION

- 1.1 Documentation, the Key Factor
- 1.2 Major Implementation Activities
 - 1.2.1 Define and Document, the Plant and Process
 - 1.2.2 Determine User Needs (Operators, Supervisors, Engineers, Others)
 - 1.2.3 Select Equipment
 - 1.2.4 Do Hardware Configuration and Site Planning
 - 1.2.5 Collect Implementation Data
 - 1.2.6 Install and Start Up the Equipment
 - 1.2.7 Enter Implementation Data
 - 1.2.8 Reconfigure

2 OVERVIEW OF MAJOR IMPLEMENTATION ACTIVITIES

- 2.1 Define and Document the Process
 - 2.1.1 Dependencies
 - 2.1.2 Documentation
- 2.2 Determine User Needs
 - 2.2.1 Dependencies
 - 2.2.2 Documentation
- 2.3 Select Equipment
 - 2.3.1 Dependencies
 - 2.3.2 Documentation
- 2.4 Configure Hardware and Plan the Site(s)
 - 2.4.1 Dependencies
 - 2.4.2 Documentation
- 2.5 Collect Implementation Data
 - 2.5.1 Dependencies
 - 2.5.2 Documentation
- 2.6 Install, Startup, and Checkout System Hardware
 - 2.6.1 Dependencies
 - 2.6.2 Documentation
- 2.7 Enter Implementation Data
 - 2.7.1 Dependencies
 - 2.7.2 Documentation
- 2.8 Reconfiguration
 - 2.8.1 Dependencies
 - 2.8.2 Documentation

3 ENGINEERING PERSONALITY ACTIVITIES

INTRODUCTION Section 1

This section provides a high-level overview of the implementation process.

1.1 DOCUMENTATION, THE KEY FACTOR

The complete implementation process for a new system includes planning, design, and documentation. Of these, good documentation can do more to minimize mistakes and false steps than any other factor. Good documentation is also vital to successful reconfiguration of part of a system that has been monitoring and controlling the process.

Honeywell provides forms on which you can document most of your implementation design and data, but the configuration forms don't document all implementation data. In this overview and in the *Engineer's Reference Manual*, we indicate other activities for which you should prepare your own documents.

1.2 MAJOR IMPLEMENTATION ACTIVITIES

The major activities in the complete, first time, implementation process are listed below. The items under the bold headings are factors that are considered in these activities. In the remainder of this publication, we provide an overview of each of these activities and provide help in locating the information you will need.

Reconfiguration of part of an existing system consists of parts or all of some of these major activities, and they often require special installation and data entry procedures, which are provided in the Honeywell publications mentioned in Section 2.

1.2.1 Define and Document, the Plant and Process

- P & I Diagrams
- Point Types
- Point Counts

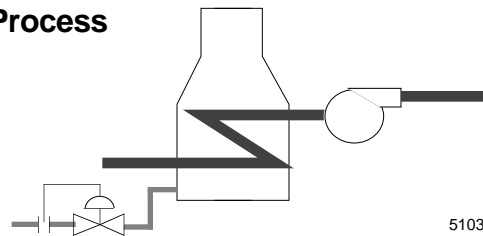

1.2.2 Determine User Needs (Operators, Supervisors, Engineers, Others)

- Assign consoles to users
- Assign points to units
- Assign units to consoles
- Define custom displays
- Define button configuration
- Define history collection requirements
- Define logs and reports
- Define trend recorder requirements

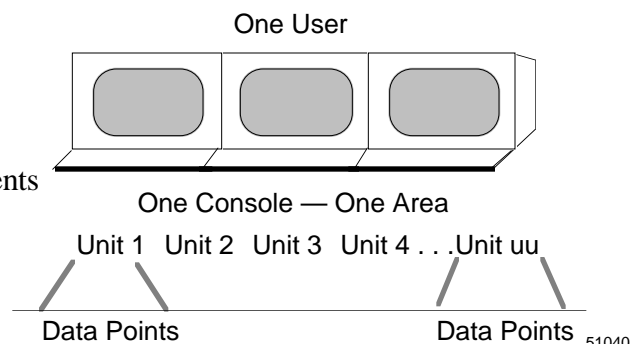

1.2.3 Select Equipment

- Performance Considerations
- Universal Stations
 - standard (US) or X level (UXS)
 - Cartridge Drives, Printers, Trend Recorders
- Universal Control Networks, PMs, APMs, HPMs, LMs SMs
- Data Hiways, Hiway Gateways (HG), Controllers
- Application Modules - standard (AM) or X level (AXM).
- CM50s (Digital Equipment Corporation; VAX & MICROVAX)
- CM60s (Honeywell Bull; DPS6s)
- Computer Gateways (CG)
- History Modules (HM)
 - Volume Assignments and Sizes
 - System Volumes
 - User Volumes
 - History Volumes
 - Directories

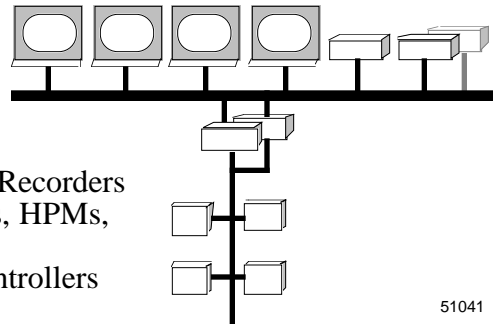

51041

1.2.4 Do Hardware Configuration and Site Planning

- Equipment Configuration
 - Nodes on each Universal Control Network
 - NIMs—Redundant or Remote?
 - Boxes on Each Hiway
 - HGs—Redundant, Remote or Added?
 - Nodes on LCNs, Redundant?
 - How Many of Each Type?
 - USs, Furniture
 - CM50 Equipment
 - CM60 Equipment
 - CGs, Computers
 - Printers
 - Trend Recorders
 - Cartridge Drives
 - Telephones, Radios, Clocks,
 - Storage Cabinets, Chairs, Desks

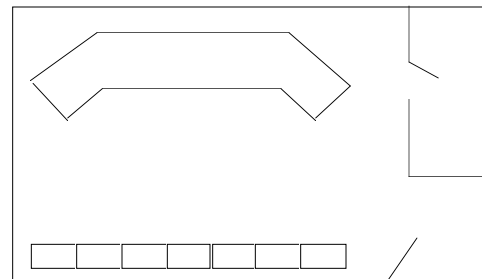

51042

1.2.5 Collect Implementation Data

- Performance Data
 - Point Count/Point Types/Unit Mix
 - Preliminary AM Memory Allocation
- HM Performance Data
 - Volume and Directory Management
 - HM and Cartridges
- Fill out Configuration Forms
- Do LM Ladder Logic
- Do CL Program Design
- Do Pascal Program Design

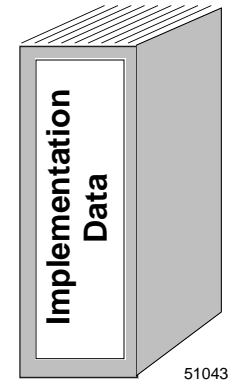

51043

1.2.6 Install and Start Up the Equipment

- Move equipment into place
- Install cabling and wiring
- Apply power
- Equipment checkout

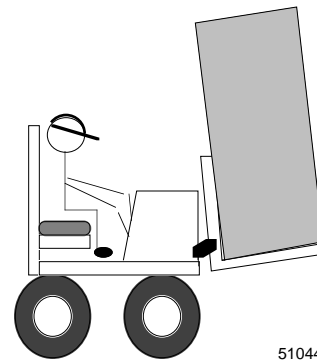

51044

1.2.7 Enter Implementation Data

- Per System Startup Guide for new systems
- Changes, Expansions, Upgrades

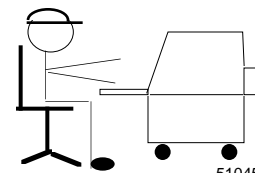

51045

1.2.8 Reconfigure

- Determine which installation units you need
- Determine system impact
- Plan and schedule on-line reconfiguration

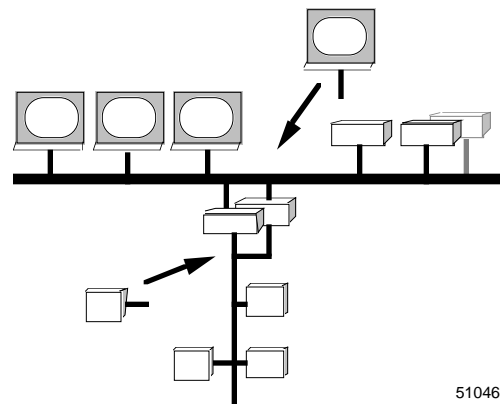

51046

OVERVIEW OF MAJOR IMPLEMENTATION ACTIVITIES

Section 2

For each of the major implementation activities, this section defines the purpose, outlines the activity, defines any dependencies, and discusses related documentation.

2.1 DEFINE AND DOCUMENT THE PROCESS

Determine the mix of point types, algorithms, and other options that are required. This activity includes the definition of types of control and data acquisition that are needed, and leads to the definition of the mix of equipment.

This activity includes identification of the need for custom control or data acquisition using Honeywell's Control Language, Pascal, or FORTRAN.

2.1.1 Dependencies

None.

2.1.2 Documentation

User-supplied documents include:

- Piping and instrumentation diagrams or any other drawings that depict the data acquisition and control strategy or strategies.
- Point lists, including point types and the counts of the points of each type.

Honeywell doesn't provide forms for the collection of data for this activity. Refer to the following publications:

System Overview in the *System Summary* binder.

System Control Functions in the *Implementation/Startup & Reconfiguration - 2* binder.

Application Module^X User Guide in the *Application Module^X* binder.

Application Module Algorithm Engineering Data and *Application Module Control Functions* in the *Implementation/Application Module - 1* binder.

High-Performance Process Manager Control Functions and Algorithms in the *Implementation/High-Performance Process Manager - 1* binder.

Advanced Process Manager Control Functions and Algorithms in the *Implementation/Advanced Process Manager - 1* binder.

Process Manager Control Functions and Algorithms in the *Implementation/Process Manager - 1* binder.

Logic Manager Control Functions in the *Implementation/Logic Manager* binder.

Safety Manager Control Functions in the *Implementation/Safety Manager* binder.

Hiway Gateway Control Functions in the *Implementation/Hiway Gateway - 1* binder.

Control Language/Application Module Overview in the *Implementation/Application Module - 3* binder.

Control Language/Process Manager Reference Manual in the *Implementation/Process Manager - 2* binder.

Control Language/Advanced Process Manager Reference Manual in the *Implementation/Advanced Process Manager - 2* binder.

CM50S User Manual in the *Implementation/CM50S - 2* binder.

Computer Gateway User Manual in the *Implementation/Computer Gateway* binder.

2.2 DETERMINE USER NEEDS

Consider not only the needs of process operators, but also the needs of others who can make use of the process data and system data that this system can acquire. These may be supervisors, engineers, plant maintenance people, cost analysts and managers. While it may not be convenient for anyone but a process operator to have access to a console while the system is on-line, many types of printed logs and reports can be devised by using the information gathered by the system's continuous history functions.

Either now or when the process is defined, you should develop a fairly complete list of all of the data points you will use, with their tag names, and possibly with some reference to schematic displays, logs, or reports where the data for each point will appear. If process operators or other users can make good use of trend recorders, you should plan to use them now.

Determine which points are to provide historical data and the type of data (snapshots or user averages) that is to be collected for each.

Because system performance is so important to its users, you should become familiar now with the information in Section 23, *Configuring for Performance*, in the *Engineer's Reference Manual*. Section 23 introduces the cluster concept, and the preferred relationship of the cluster, consoles, process areas, and process units.

2.2.1 Dependencies

If the mix of equipment for this system is not already known, this activity leads to the selection of equipment in the next major activity. If the complement of equipment has been determined, only the use of each piece of equipment determined in the next activity.

This activity provides information to determine the amount of HM storage space needed, and leads to the determination of what data will be stored in each HM.

2.2.2 Documentation

User-supplied documents include drawings or lists that define users, consoles, areas assigned to consoles, units in each area, data points in each unit, history collection requirements, and required logs and reports. For schematics (custom or graphic displays), at least a simple sketch or textual description of each should be prepared. The actual design of the schematics must be accomplished sometime during or after this activity, but before the schematics are built during configuration data entry.

The following Honeywell-supplied publications support this activity:

History Module History Group Forms in the *Implementation/Configuration Forms* binder.

HM History Group Form Instructions in the *Implementation/Engineering Operations - 1* binder.

Picture Editor Forms in the *Implementation/Configuration Forms* binder.

Picture Editor Form Instructions in the *Implementation/Engineering Operations - 2* binder.

Picture Editor Reference Manual in the *Implementation/Engineering Operations - 2* binder.

Button Configuration Forms in the *Implementation/Configuration Forms* binder.

Button Configuration Form Instructions in the *Implementation/Engineering Operations - 1* binder.

Free Format Log Forms in the *Implementation/Configuration Forms* binder.

Free Format Log Form Instructions in the *Implementation/Engineering Operations - 1* binder.

2.3 SELECT EQUIPMENT

If the mix of equipment to be used on your system is not yet determined, this is the time to make the selection. If the equipment has already been selected, this activity consists only of assigning functions and data to reside in specific pieces of equipment.

Selecting the equipment to be used requires knowledge of the process and the user's needs, as well as knowledge of the purpose, functions, performance, and capacity of each equipment item. Typically, this is a joint effort between customer personnel and a Honeywell sales engineer. "Equipment," as used here means the LCN-based, UCN-based, and Data Hiway-based equipment supplied by the Honeywell Industrial Automation Controls Division.

During this activity, you should become familiar with these two important considerations for equipment configuration and for assigning functions and data to specific equipment:

- **Configuring for performance**—Using the cluster concept, Honeywell Control Units (HCUs), and predicting AM performance. These are discussed in Section 23 of the *Engineer's Reference Manual*.
- **Volume Configuration**—Assigning volumes to HMs for convenience and for effective use of HM storage space. These are discussed in Section 7 of the *Engineer's Reference Manual*.

2.3.1 Dependencies

Of course, the mix of equipment on the LCN, UCN, and the Data Hiway must be such that the desired functions are present, and the capacity and throughput of each type of device is sufficient to support and communicate with the other device types.

- For LCN-based nodes, the cluster, as defined in Section 23 of the *Engineer's Reference Manual* assures such compatibility.
- For UCN-based nodes, each NIM pair is intended to connect to one Universal Control Network that can have up to 64 addressable nodes. Information on configuration of the High-Performance Process Managers, Advanced Process Managers, Process Managers, Logic Managers, and Safety Managers is provided in Product Reference Binders.
- For hiway-based devices, the device mix can vary considerably, so long as the rules for use of HTDs and preferred access devices are followed. Each HG pair is intended to connect to one Data Hiway with up to 63 addressable devices, if an HTD is present. Information on configuration of HGs and the hiway is provided in Section 1 of the *Hiway Gateway Implementation Guidelines* manual.

The next activity depends on the completion of this activity, because the physical site(s), environment, and power requirements depend on the equipment to be supported.

From this point on, every one involved in system implementation should keep in mind that there should be **adequate capacity in nearly every room, power source, network, hiway, and device to accommodate expansions that are almost certain to be needed in the future**. Also, all estimates of needed capacity should be considered only as estimates, and enough additional capacity should be provided to accommodate underestimates.

2.3.2 Documentation

User-supplied documents include equipment lists, sketches that show LCN-, UCN-, and hiway-based device complements, performance predictions, storage capacity estimates, tentative assignments of units to AMs, NIMs, and HGs, and tentative HM volume assignments.

Refer to the following sections of the *Engineer's Reference Manual* in the *Implementation/Startup & Reconfiguration* - 2 binder:

Section 23, *Configuring for Performance*

Section 8, *Hiway, Box, and Slot Configuration Guidelines*

Section 7, *HM Set Up and Initialization*

- To select LCN-based devices, refer to these publications:

System Overview in the *System Summary* binder.

All of the *Technical Data* publications in the *System Summary* binder.

- To select UCN-based devices, refer to the applicable manual(s)—
 - High-Performance Process Manager Specification and Technical Data* in the *Implementation/High-Performance Process Manager - 1* binder,
 - Advanced Process Manager Specification and Technical Data* in the *Implementation/Advanced Process Manager - 1* binder,
 - Process Manager Specification and Technical Data* in the *Implementation/Process Manager - 1* binder
 - Logic Manager Specification and Technical Data* in the *Implementation/Logic Manager* binder.
 - Safety Manager Specification and Technical Data* in the *Implementation/Safety Manager* binder.
- To select hiway-based devices, refer to the *Technical Data and Specifications* for each device in the *Product Manual* binder(s) in the BASIC System bookset.

2.4 CONFIGURE HARDWARE AND PLAN THE SITE(S)

Configuring the hardware and planning the sites consists of the following tasks:

- Assign Universal Control Networks to physical process areas; assign NIMs, LMs, SMs, HPMs/APMs/PMs to each UCN, as required.
- Assign Data Hiways to physical process areas; assign boxes, HTDs, and HGs to each hiway, as required.
- Assign nodes to LCNs.
- Assign USs to consoles and peripheral devices to USs.
- Determine cabinet and furniture requirements, and assign devices to cabinets and enclosures.
- Plan cabinet and furniture placement, cabling, and power sources.
- Make sure there is sufficient space and floor strength on the route from the loading dock to the site for each piece of equipment.
- Provide sufficient heating, cooling, and air conditioning.
- Provide safety equipment and devices.
- Provide storage for spare parts and tools.
- Provide safe, secure storage for cartridges disks (you probably need more space than you think).
- Provide convenience and comfort items.

2.4.1 Dependencies

The relationships of these tasks to each other, and of this activity to the other major activities are fairly obvious. If you don't have enough space, power, access, etc., you will have to do without, rebuild, or rearrange things.

2.4.2 Documentation

User supplied documents include plans, cabling and wiring diagrams, purchase orders for auxiliary items, and construction permits.

The following Honeywell-supplied publications support this activity:

- For LCN-based devices; *LCN Planning* manual in the *System Site Planning - 1* binder.
- For UCN-based devices; *UCN Planning* in the *System Site Planning - 1* binder and *UCN Installation* manual in the *Installation/Universal Control Network* binder.
- For hiway-based devices; *Data Hiway Subsystem Site Planning* in the *System Summary* binder in the BASIC System bookset.

2.5 COLLECT IMPLEMENTATION DATA

This activity often takes place at the same time as some of the other activities. You should collect all of your implementation data, including the information in user-supplied documents and on Honeywell-supplied configuration forms, in one place, where it can be made available for those who need it, and where revision control is maintained.

2.5.1 Dependencies

This activity is closely related to implementation data entry and to reconfiguration. We suggest that this paper work should be completed before any attempt is made to enter any new implementation data in the system. All changes that are made to the data by anyone entering implementation data at a console should be recorded in these documents.

2.5.2 Documentation

User-supplied documents include all of the user-supplied documents mentioned in the preceding activities, plus all configuration forms; all program, schematic, button, and exception-build source files, all command files, and any other documents prepared in the design process.

The following Honeywell-supplied publications support this activity:

- *Configuration Data Collection Guide* in the *Implementation/Startup & Reconfiguration - 2* binder.
- *Engineer's Reference Manual* in the *Implementation/Startup & Reconfiguration - 2* binder.

2.6 INSTALL, STARTUP, AND CHECKOUT SYSTEM HARDWARE

Move the equipment into place, connect power wiring and grounds, connect cables, apply power, and verify proper hardware operation.

2.6.1 Dependencies

Obviously, data entry is impossible unless the equipment is running. It isn't always necessary to have all of the equipment running, but on LCNs, many data-entry activities require all of the nodes to be running. Loading data points through the Data Entity Builder (DEB) requires all modules and gateways to be running their on-process personalities (OK status on the node status displays), and all nodes on the Universal Control Networks and the boxes on the Data Hiways to be running and ready to accept data.

2.6.2 Documentation

User-supplied documents include data recorded during the installation and checkout process including trouble reports, test data, and any logs kept during the activity.

The following Honeywell-supplied publications support this activity:

For the LCN System:

- *LCN System Installation* manual in the *LCN Installation* binder.
- *LCN System Checkout* manual in the *LCN Installation* binder.

For the nodes on the UCN:

- *High-Performance Process Manager Installation* and the *High-Performance Process Manager Checkout* manuals in the *Implementation/HPM - 1* binder.
- *Process Manager/Advanced Process Manager Installation* and the *Process Manager/Advanced Process Manager Checkout* manuals in the *Implementation/PM/APM* binder.
- *Logic Manager Implementation Guidelines* in the *Implementation/Logic Manager* binder.
- *Safety Manager Implementation Guidelines* in the *Implementation/Safety Manager - 1* binder.

For the devices on the hiways:

- All of the publications under the *BASIC System Installation* tab in the *System Summary* binder in the Basic System bookset.

2.7 ENTER IMPLEMENTATION DATA

If this is the first time the system has been started up (other than applying power and verifying hardware operation), we strongly recommend that you do the tasks in the *System Startup Guide*. Use the implementation data that you have collected thus far, in place of the examples of data that are provided in the *System Startup Guide*. You don't have to build the complete system as you go through the *System Startup Guide*, just do enough to define the network, initialize and configure the HM, build some data points, build one or more schematics (pictures), configure some buttons, and load the Operator Personality in a US.

After you have gone through the tasks in the *System Startup Guide*, you can enter the remaining data in the system. Refer to Section 3 of this publication to see which Engineering Personality activities are used to enter each type of data.

Once you have the system started, you can continue configuring and reconfiguring, but several types of configuration changes require special on-line reconfiguration techniques. Figure 14-1 in Section 14 of the *Engineer's Reference Manual* indicates which changes can be made at any time, and which require the special techniques.

2.7.1 Dependencies

There are many important dependencies within data entry and between data entry and the other major activities, and it's not practical to define all of them here. Section 14 of the *Engineer's Reference Manual* defines "data binding," and it is data binding that causes these dependencies. Once interrelated data is entered in the system and "bound," the work needed to change it is no longer simple. Section 14 of the *Engineer's Reference Manual* defines when each type of data is bound, and what special techniques may be needed to change it. Changing such data may sound complicated and dangerous, but it isn't as complicated as it may seem, and it isn't dangerous, if you are careful. Check Section 14 if you are not sure, particularly Figure 14-1.

One important dependency is volume configuration. If, during the data entry process, you discover that a volume on the HM isn't large enough or if checkpoints files were too small, you will have to redo volume configuration to make it larger, or you will have to find some other remedy, such as using a cartridge disk instead of the HM. Changes to volume configuration require that all of the data on the HM be copied to cartridge disks, that the volume be reconfigured, the HM be initialized, and all of the data copied back to the HM. This can be a lengthy process and can put the HM out of service for the better part of a day. **This is an example of why it is so important to plan ahead and do the paperwork first.**

2.7.2 Documentation

User-supplied documents include filled-out configuration forms and the data to be entered through the Text Editor in the source files for schematics, button configuration, exception building, CL programs, and command files.

The following Honeywell-supplied publications support this activity:

Configuration Data Collection Guide in the *Implementation/Startup & Reconfiguration - 2* binder.

Engineer's Reference Manual in the *Implementation/Startup & Reconfiguration - 2* binder.

All of the *Data Entry* instructions in the *Implementation* binders (see Section 3 of this *Implementation Overview*).

Data Entity Builder Manual in the *Implementation/Implementation/Startup & Reconfiguration - 1* binder.

High-Performance Process Manager Parameter Reference Dictionary in the *Implementation/HPM- 2* binder.

Advanced Process Manager Parameter Reference Dictionary in the *Implementation/Advanced Process Manager - 2* binder.

Process Manager Parameter Reference Dictionary in the *Implementation/Process Manager - 2* binder.

Logic Manager Parameter Reference Dictionary in the *Implementation/Logic Manager* binder.

Safety Manager Parameter Reference Dictionary in the *Implementation/Safety Manager* binder.

Hiway Gateway Parameter Reference Dictionary in the *Implementation/Hiway Gateway - 1* binder.

Hiway Gateway Implementation Guidelines in the *Implementation/Hiway Gateway - 1* binder.

Application Module Parameter Reference Dictionary in the *Implementation/Application Module - 2* binder.

Computer Gateway Parameter Reference Dictionary in the *Implementation/Computer Gateway* binder.

2.8 RECONFIGURATION

Before you attempt any type of reconfiguration, it's a good idea to refer to Figure 14-1 in the *Engineer's Reference Manual* to see if the item you need to change is one of the network configuration items that requires on-line reconfiguration. If it is, you will need to do some planning to get the change implemented. On-line reconfiguration involves the use of defined installation units to get the changes installed in the system, and this requires shutting down and restarting one or more nodes. The point is, that you will need to devise a shutdown and startup sequence that either maintains control paths from the LCN to the valves in the process or that is accomplished when it is possible to go "off process."

Other types of configuration changes, such as adding data points or CL programs can be done at any time, unless the changes will affect some "on-process" activity.

2.8.1 Dependencies

Same as 2.7.1.

2.8.2 Documentation

Same as 2.7.2.

ENGINEERING PERSONALITY ACTIVITIES Section 3

This section provides a quick summary of the use of each of the targets (picks) on the Engineering Main Menu. It also provides reminders about source information, dependencies, and the publications that provide instructions for each activity.

The complete Engineering Menu is reproduced below, and the description of each activity is listed in Table 3-1.

ENGINEERING MAIN MENU				
UNIT NAMES		HIWAY GATEWAY		PICTURE EDITOR
AREA NAMES		LOGIC BLOCKS		FREE FORMAT LOGS
CONSOLE NAMES		APPLICATION MODULE		BUTTON CONFIGURATION
LCN NODES		COMPUTING MODULE		HM HISTORY GROUPS
SYSTEM WIDE VALUES		NETWORK INTERFACE MODULE		
VOLUME CONFIGURATION				DOCUMENTATION TOOL
				AREA DATA BASE
		BUILDER COMMANDS		
Support Functions and Utility Programs				
COMMAND PROCESSOR	SYSTEM MENU	SYSTEM STATUS	CONSOLE STATUS	
SUPPORT UTILITIES	SMCC/ MAINTENANCE	R500 (C) HONEYWELL INC., 1984		

53629

Table 3-1 Engineering Menu Activities

Activity	Description
Network Configuration	
UNIT NAMES	<p>Purpose: Enter unit IDs and unit descriptors. Source Information: Network Configuration Forms Dependencies: See subsection 14.1 and Table 14-2 the <i>Engineer's Reference Manual</i> Instructions: Network Data Entry</p>
AREA NAMES	<p>Purpose: Enter area IDs and area descriptors. Source Information: Network Configuration Forms Dependencies: See subsection 14.1 and Table 14-2 the <i>Engineer's Reference Manual</i> Instructions: Network Data Entry</p>
CONSOLE NAMES	<p>Purpose: Enter Descriptors for each console. Source Information: Network Configuration Forms Dependencies: See subsection 14.1 and Table 14-2 the <i>Engineer's Reference Manual</i> Instructions: Network Data Entry</p>
LCN NODES	<p>Purpose: Configure nodes on the LCN. Add or delete nodes (on-line reconfiguration). Source Information: Network Configuration Forms Dependencies: See Section 14, particularly Table 14-2, in the <i>Engineer's Reference Manual</i> Instructions: Network Data Entry</p>
SYSTEM-WIDE VALUES	<p>Purpose: Enter values used throughout the system, such as shift-start times, shift length, user access levels, etc. Source Information: Network Configuration Forms Dependencies: See Section 14, particularly Table 14-2 the in the <i>Engineer's Reference Manual</i> Instructions: Network Data Entry</p>
VOLUME CONFIGURATION	<p>Purpose: Configure volumes on HMs. Add or delete HM volumes (on-line reconfiguration). Source Information: Network Configuration Forms Dependencies: See Sections 7 and 14 in the <i>Engineer's Reference Manual</i> Instructions: Network Data Entry</p>

(Continued)

Table 3-1 Engineering Menu Activities (Continued)

Activity	Description
Point Building	
HIWAY GATEWAY	<p>Purpose:</p> <ul style="list-style-type: none"> • Define each Data Hiway to the system • Define each device (box/slot) on a Data Hiway • Build HG Data points • Build HG Library <p>Source Information:</p> <ul style="list-style-type: none"> • Network Configuration Forms • HG Data Point Forms • HG Library Forms <p>Dependencies: Information is to be loaded in the following order:</p> <ol style="list-style-type: none"> 1. Data Hiway configuration 2. Box/slot configuration See Sections 14 and 17 in the <i>Engineer's Reference Manual</i>. 3. See Section 3.9.1 in CL Data Entry for HG Library dependencies. <p>Instructions: <i>Data Entity Builder Manual</i></p>
LOGIC BLOCKS	<p>Purpose: Build MC Logic Blocks</p> <p>Source Information: Logic Block Forms</p> <p>Dependencies: The associated hiway and box/slot entities must be loaded before Logic Blocks can be loaded.</p> <p>Instructions: Logic Block Data Entry</p>
APPLICATION MODULE	<p>Purpose: Build AM Data Points</p> <p>Source Information: AM Data Point Forms</p> <p>Dependencies: See Sections 14 and 17 of the <i>Engineer's Reference Manual</i>.</p> <p>Instructions: <i>Data Entity Builder Manual</i></p>
COMPUTING MODULE	<p>Purpose: Build CM50 or CM50S (CIU) Data Points</p> <p>Source Information: CM50S Computer Gateway Forms</p> <p>Dependencies: See Sections 14 and 17 of the <i>Engineer's Reference Manual</i>.</p> <p>Instructions: <i>Data Entity Builder Manual</i></p>
NETWORK INTERFACE MODULE	<p>Purpose:</p> <ul style="list-style-type: none"> • Define each NIM to the system • Define each PM/APM/HPM to the system • Define each LM/SM to the system • Build PM/APM/HPM Data Points • Build LM/SM Data Points <p>Source Information: PM/APM/HPM LM and SM Forms</p> <p>Dependencies: Information is to be loaded in the following manner:</p> <ol style="list-style-type: none"> 1. UCN Node Configuration/each node 2. Node Specific Config./each node 3. Point Configuration/each node <p>Instructions: <i>Data Entity Builder Manual</i></p>

(Continued)

Table 3-1 Engineering Menu Activities (Continued)

Activity	Description
Point Building (Continued)	
BUILDER COMMANDS	<p>Purpose: Go directly to the Data Entity builder Command Display</p> <p>Source Information: None</p> <p>Dependencies: None</p> <p>Instructions: <i>Data Entity Builder Manual</i></p>
Functions	
<p>PICTURE EDITOR</p> <p>FREE FORMAT LOGS</p> <p>BUTTON CONFIGURATION</p> <p>HM HISTORY GROUPS</p> <p>AREA DATABASE</p>	<p>Purpose: Build schematic (custom, graphic) displays</p> <p>Source Information: Picture Editor Forms</p> <p>Dependencies: See subsection 14.6 in the <i>Engineer's Reference Manual</i></p> <p>Instructions: Picture Editor Data Entry</p> <p>Purpose: Define Free Format Logs to be displayed or printed on a printer.</p> <p>Source Information: Free Format Log Forms</p> <p>Dependencies: Subsection 14.6 in the <i>Engineer's Reference Manual</i> applies to Free Format Logs as well as to Pictures.</p> <p>Instructions: Free Format Log Data Entry</p> <p>Purpose: Define functions of the configurable buttons on the Operator's Keyboard.</p> <p>Source Information: Button Configuration Forms</p> <p>Instructions: Button Configuration Data Entry</p> <p>Purpose: Assign points to HM History Groups</p> <p>Source Information: HM History Group Forms</p> <p>Dependencies: Values entered in Volume Configuration that are related to continuous history must be known. Point names must also be known.</p> <p>Instructions: <i>Data Entity Builder Manual</i></p> <p>Purpose: Define the functions for an area, including unit assignments, displays for the area, journals, reports, and logs.</p> <p>Source Information: Area Forms</p> <p>Dependencies: See Section 13 in the <i>Engineer's Reference Manual</i>.</p> <p>Instructions: <i>Data Entity Builder Manual</i></p>

(Continued)

Table 3-1 Engineering Menu Activities (Continued)

Activity	Description
Support Functions and Utility Programs	
<p>COMMAND PROCESSOR</p>	<p>Purpose:</p> <ul style="list-style-type: none"> • Create and edit source files for CL programs, Logic Blocks, and exception building. Also used to create and edit command files, and DEB command files. • Compile, link, and load CL programs for AMs, PM/APM/HPMs, and MCs. • Execute any of the utilities to format removable media, copy files/volumes, create volumes, create directories to volumes, assign aliases, display and print files, list files, etc. <p>Source Information:</p> <ul style="list-style-type: none"> • CL source files prepared with Text Editor. • Information noted as the need for the utilities arises. <p>Dependencies:</p> <ul style="list-style-type: none"> • Several engineering activities require use of the Command Processor. These requirements are noted in the appropriate Data Entry publications. • See Section 2 in CL Data Entry for CL dependencies. <p>Instructions:</p> <ul style="list-style-type: none"> • <i>Data Entity Builder Manual</i> • Utilities operation • CL Data Entry
<p>SYSTEM MENU</p>	<p>Purpose: Call up the System Menu, which offers several system-level functions that are available in both the Engineering and Operator's personalities.</p> <p>Instructions: <i>Process Operations Manual</i></p>
<p>SYSTEM STATUS</p>	<p>Purpose: Calls up the System Status Display, which shows the status of the nodes on the LCN. This display is available in both the Engineering and the Operator's personalities.</p> <p>Instructions: <i>Process Operations Manual</i></p>
<p>CONSOLE STATUS</p>	<p>Purpose: Calls up the Console Status Display, which shows the status of the Consoles on the LCN. This display is available in both the Engineering and the Operator's personalities.</p> <p>Instructions: <i>Process Operations Manual</i></p>

(Continued)

Table 3-1 Engineering Menu Activities (Continued)

Activity	Description
Support Functions and Utility Programs (Continued)	
<p>SUPPORT UTILITIES</p>	<p>Purpose: Provides access to the Modify Volume Pathnames display that is used to specify the pathnames used by most of the engineering activities (also provides access to TAC Support Functions, and Translators, which are reserved for use by Honeywell).</p> <p>Source Information: The need to change the pathnames is usually indicated by prompts on the engineering displays that ask for volumes to be mounted.</p> <p>Dependencies: Several engineering activities require use of the File Manager Utilities. These requirements are noted in the appropriate Data Entry publications.</p> <p>Instructions: <i>Command Processor Operation</i></p>
<p>SMCC/MAINTENANCE</p>	<p>Purpose: Calls up the system maintenance functions.</p> <p>Instructions: <i>System Maintenance Guide, Maintenance Test Operations</i></p>

Communications concerning technical publications should be directed to:

Automation College
Industrial Automation and Control
Honeywell Inc.
2820 West Kelton Lane
Phoenix, Arizona 85023-3028

FOLD

FOLD

From: _____



NO POSTAGE
NECESSARY
IF MAILED
IN THE USA

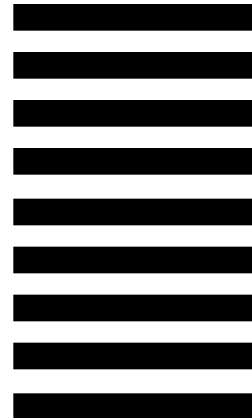

Cut Along Line

BUSINESS REPLY MAIL
FIRST CLASS PERMIT NO. 4332 PHOENIX, ARIZONA

POSTAGE WILL BE PAID BY

Honeywell

Industrial Automation and Control
2820 West Kelton Lane
Phoenix, Arizona 85023-3028

Attention: Manager, Quality

FOLD

FOLD

Additional Comments:

Honeywell

Industrial Automation and Control
Honeywell Inc.
16404 North Black Canyon Highway
Phoenix, Arizona 85023-3033

Helping You Control Your World