

## TDC 3000X

### Operator's Digest

SW11-515

R510

4/96

## CONTENTS

Continuous Operating Displays .....	3
Point Parameter Changes.....	6
Sequence Operations, PM Group, PM Detail.....	8
Timers.....	9
Numerics, Logic Blocks, Flags.....	10
Load a Sequence Program.....	11
Save a Sequence Program .....	12
Change Module Operating State.....	13
Change Sequence Execution State and Mode .....	14
Select Sequence Override.....	15
Alarm Functions, Silence Horn, Acknowledge Local Alarms .....	16
Acknowledge System Alarms, Ack. Hiway/UCN Alarms .....	17
Lost Event Recovery, Ack. Process Alarms.....	18
Ack. Messages, Confirm and Clear Messages.....	19
Initial Load Universal Station from Cartridge.....	20
Load a Universal Station	
From the History Module.....	21
From Another US In the Console.....	22
From a Fastload Cartridge.....	25
Using Cartridges .....	27
Personality from a Cartridge .....	28
System Status Commands, Display, Change Time/Date.....	29
Console Status Commands, Display/Change Unit Status.....	30
Area Change, Change Printer Assignment.....	31
View Peripheral Status Maintenance Information .....	32
System Status Commands, Displays, Load/Dump, Shut Down ...	33
Swap LCN Cables, Load NIM, HG, AM, HM, CM50.....	34
Units of AM, CM, History Collection, Hiway Alarming .....	35

*Continued ...*

**Note:** On any station that does not have a touchscreen, selection is accomplished by moving the cursor to a target and pressing the keyboard SELECT key or mouse (UWS) pushbutton.

The contents and procedures in this digest may vary somewhat from those applicable to your system because of continuing product evolution.

## CONTENTS, continued

Hiway Status Commands, Display, Box Descriptors .....	36
Trend Memory (CB), Swap Hiway Cables, Box Address .....	37
Hiway Swaps, Periodic Swaps, Box Control State .....	38
Hiway Checkpointing, Box Commands .....	39
Box Commands (RCD).....	40
UCN Status Commands, Display.....	41
UCN, PM Control State.....	42
Auto Checkpointing, UCN Cable .....	43
UCN Auto. Cable Swaps, Idle or Start PM, APM .....	44
Idle, Shutdown, or Swap PMM, APMM, I/O Processor.....	45
Database Save (Checkpoint) Functions, Save AM, CM dbase ....	46
Autosave NIM, HG, AM, CM, Save/Load Box Database.....	47
Save/Load Box Database .....	48
Save/Load PM/NIM/LM/APM Database.....	49
Trend Functions, Group Trend.....	50
Group Trend Print, Trend Pen Recording.....	53
Optional Enhanced Trend Pen Recording .....	54
Hourly Averages.....	56
System Menu Functions, Organizational Summaries.....	57
Reports, Logs, Journals, Printed Trends.....	60
Real-Time Journal.....	61
Event History Menu.....	62
Process Variable Retrieval.....	63
Group Display Edit Function .....	64
Overview Edit Display, Removable Media Initialization.....	65
Custom Name Save, Clear Screen, HTD Panel Ops.....	66
Alarm and Status Indicators.....	67
Error Messages .....	88
Point Attribute Descriptions.....	90
Universal Station X Windows .....	92
RULA Disconnect Procedures.....	93
TDC 3000 <sup>X</sup> Acronyms .....	94

### LEGEND



Engineer



Visible Touch Target

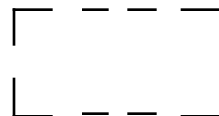

Invisible Touch Target

Keyboard Button



Target on System Menu



Indicates that the keyswitch must be in the Supervisor's position. The Supervisor's access level can be activated on the Universal Work Station by pressing keyboard keys [shift + PF1].



Indicates that the keyswitch must be in the Engineer's position. The Engineer's access level can be activated on the Universal Work Station by pressing keyboard key [PF1].

# CONTINUOUS OPERATING DISPLAYS

## General Operating Keys

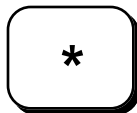

User-configured function key is configured for a designated action



Calls up an Associated Display



Calls up a preconfigured help display associated with the current display



Calls up the display that was shown immediately before the current display



Calls up the next higher numbered display, for example, going from group 1 to group 2



Calls up the next lower numbered display



Clears an incorrect or unwanted operator entry at any time before the ENTER key is pressed



Enters any information that has been typed



These four keys are used to position the cursor vertically or horizontally to any position on the display











Selects an item at the current cursor position on a display











Enables fast screen update on a group or detail display

# CONTINUOUS OPERATING DISPLAYS

## Schematic









<b>Call up procedure</b>	<p>Action: Press: </p> <p>Response: Prompt: ENTER SCHEMATIC NAME</p> <p>Action:  + </p> <p>└ type in the schematic name</p> <p>Response: Schematic display appears on the screen</p>
<b>Target selection for a schematic</b>	<p>Action: Use touch screen or Press:  to select screen targets</p> <p>   + </p> <p>Response: Selected target action is initiated</p>

## Group

<b>Call up procedure</b>	<p>Action: Press: </p> <p>Response: Prompt: ENTER GROUP NUMBER</p> <p>Action:  + </p> <p>└ type in group number 1-400</p> <p>Response: Group display appears on the screen</p>
<b>Selecting a point on a group display</b>	<p>Action: Use touch screen or Press:  to select screen targets</p> <p>   + </p> <p>Response: Selected point is highlighted</p>

# CONTINUOUS OPERATING DISPLAYS, continued



















## Detail

<p><b>Call up procedure from a group display</b></p>	<p>Action: Press:  + </p> <p>Response: Detail display appears on the screen</p>												
<p><b>Call up procedure from any display</b></p>	<p>Action: Select: </p> <p>Response: Prompt: ENTER TAGNAME</p> <p>Action:  + </p> <p style="margin-left: 100px;">└─ type in tag name</p>												
<p><b>Page through a detail display</b></p>	<p><i>Complete the step above to call up a detail display</i></p> <p>Action: Select: </p> <p>Response: To go to the next page on the detail display</p> <p>Action: Select: </p> <p>Response: To return to the previous pages on the detail display</p>												
<p><b>Navigate from detail display to other displays</b></p>	<p>Action: Select:  on Detail Display</p> <p>Response: The following targets appear</p> <p>Action: Select:</p> <table border="1" data-bbox="415 1556 1265 1703"> <tr> <td>FIRST</td> <td>CTL ALGO</td> <td>CTLCONCT</td> <td>CONFIG</td> <td>CL BLOCK</td> <td>CUSTOM</td> </tr> <tr> <td>PRIOR</td> <td>GROUP</td> <td>GRPHELP</td> <td>GRPASSOC</td> <td></td> <td></td> </tr> </table> <p>Response: Navigates to other operator displays</p>	FIRST	CTL ALGO	CTLCONCT	CONFIG	CL BLOCK	CUSTOM	PRIOR	GROUP	GRPHELP	GRPASSOC		
FIRST	CTL ALGO	CTLCONCT	CONFIG	CL BLOCK	CUSTOM								
PRIOR	GROUP	GRPHELP	GRPASSOC										



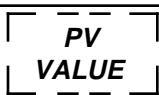

See Point Parameter Changes (following pages) for details on selecting and changing parameters.

## POINT PARAMETER CHANGES

First select the point at a Group Display, or call up the Detail Display. The following are procedures to change various parameters by pushing buttons or using touch targets.





<p><b>Changing Modes</b></p>	<p>Action: Select: </p> <p>Response: Point becomes highlighted</p> <p>Action: Press:  OR  OR </p> <p>Response: Operating mode changes to MAN, AUTO, or NORM</p>
<p><b>Changing Analog Setpoints</b></p>	<p>Action: Select: </p> <p>Response: A text box appears above the setpoint</p> <p>Action: Type in new value + </p> <p>OR</p> <p>Select one of the following buttons</p> <p>   </p> <p>Response: Setpoint changes only if point is in its proper mode</p>
<p><b>Changing Analog Outputs</b></p>	<p>Action: Select: </p> <p>Response: Point becomes highlighted</p> <p>Action: Type in new value + </p> <p>OR</p> <p>Select one of the following buttons</p> <p>   </p> <p>Response: Output value changes only if point is in its proper mode</p>
<p><b>Changing Analog Process Variables</b></p> <p></p>	<p>Action: Select: </p> <p>Response: A text box appears above the PV</p> <p>Action: Type in new value + </p> <p>Response: Process Variable value changes</p> <p><i>(Can be entered only if PV Source and point are in Manual mode.)</i></p>

# POINT PARAMETER CHANGES, continued



<p><b>Changing the PV Source mode</b></p> <p>(Point must be in MANual mode)</p> 	<p>Action: Select: <input type="text" value="PV SOURCE"/></p> <p>Response: The following targets appear</p> <p>Action: Select: <input type="text" value="AUTO"/> OR <input type="text" value="MAN"/>  <input type="text" value="SUB"/> OR <input type="text" value="TRACK"/> + <input type="text" value="ENTER"/></p> <p>Response: Process Variable Source mode changes</p>
<p><b>Changing Digital States:</b></p> <p><b>Data Hiway and UCN Points</b></p> 	<p>Action: Select: <input type="text" value="OUTPUT STATE"/></p> <p>Response: Digital Point becomes highlighted</p> <p>Action: Press: <input type="text" value="▲"/> OR <input type="text" value="▼"/></p> <p>Response: New state appears above OP% field</p> <p>Action: Press: <input type="text" value="ENTER"/></p> <p>Response: Output state changes</p>
<p><b>Changing Tuning Constant from a detail display</b></p> 	<p>Action: Select: <input type="text" value="CONSTANT"/></p> <p>Response: Text box appears</p> <p>Action: Type in new value + <input type="text" value="ENTER"/></p> <p>Response: New tuning constant is entered</p>
<p><b>Activate or deactivate an AM, PM, APM, or CM point from a detail display</b></p>	<p>Action: Select: <input type="text" value="PTEXECST"/></p> <p>Response: The following targets appear</p> <p>Action: Select: <input type="text" value="ACTIVE"/> OR <input type="text" value="INACTIVE"/></p> <p>Response: Selection becomes highlighted</p> <p>Action: Select: <input type="text" value="ENTER"/></p> <p>Response: Point becomes active or inactive</p>
<p><b>Changing all other detail display parameters</b></p>  	<p>Action: Select: <input type="text" value="PARAMETER NAME"/> OR <input type="text" value="PARAMETER VALUE"/></p> <p>Response: Text box appears</p> <p>Action: Type in new value + <input type="text" value="ENTER"/></p> <p>Response: New values are now entered</p>

# SEQUENCE OPERATIONS

## Process Module Group





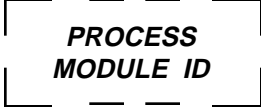







<b>Call up procedure</b>	Action: Press:  Response: Prompt: ENTER GROUP NUMBER Action:  +  └ type in group number 401 to 450 Response: Selected process module group appears on the screen
<b>Call up procedure from the Module Summary Display</b>	Action: Select:  Response: Selected process module group appears on the screen

## Process Module Detail

<b>Call up procedure</b>	Action: Press:  Response: Prompt: ENTER POINT ID Action:  +  └ Type in tagname of process module Response: Selected process module detail display appears on the screen
<b>Call up procedure from the Module Summary Display</b>	Action: Select:  Response: Selected process module detail display appears on the screen





# SEQUENCE OPERATIONS, continued

## Timers

<b>Call up a Timer</b>	Action: Select:  OR  (MC Display) (PM & APM Display) Response: Timer display appears on the screen
<b>Start, stop, or reset a Timer</b>	Action: Select:  Response: The following targets appear allowing you to change a Timer Action: Select:  to start the timer  to stop the timer  to reset the timer Response: Prompt PRESS ENTER TO EXECUTE Action: Press:  Response: Timer changes to specific target selection
<b>Preset a Timer</b>	Action: Select:  Response: The following target appears Action: Select:  Response: Prompt VALUE? with text box appears allowing you to enter a new value Action: Type in new value +  Response: Timer is now preset
<b>Change time base</b>	Action: Select:  Response: Prompt PRESS ENTER TO EXECUTE Action: Press:  Response: Time base changes (min. to sec. or sec. to min.)

# SEQUENCE OPERATIONS, continued







## Numerics

<p><b>Call up from a Process Module Detail Display</b></p>	<p>Action: Select:  OR  (MC Display) OR  (PM &amp; APM Display)</p> <p>Response: Numeric display appears on the screen</p>
<p><b>Change a numeric value</b></p>	<p>Action: Select: </p> <p>Response: Box appears to enter a numeric value</p> <p>Action: Type in Real number</p> <p>Response: Numeric value updates to show real value</p>

## Logic Blocks

<p><b>Call up from the Module Summary Display</b></p>	<p>Action: Select: </p> <p>Response: Logic Block display appears on the screen</p> <p><i>Note: Logic Blocks are associated with MC devices only</i></p>
---	--

## Flags

<p><b>Call up from a Process Module Detail Display</b></p>	<p>Action: Select:  OR  (MC Display) OR  (PM &amp; APM Display)</p> <p>Response: Numeric display appears on the screen</p> <p>Action: Select: </p> <p>Response: Numeric becomes highlighted in white</p> <p>Action: Press:  OR  + </p> <p>Response: Flag state changes</p>
--	---

# SEQUENCE OPERATIONS, continued

## Load a Sequence Program

<p><b>Loading procedure from a Process Module Display</b></p>	<p>Action: Select: <span style="border: 1px solid black; padding: 2px 10px;">LOAD SAVE</span></p> <p>Response: Load target appears on the screen</p>
<p><b>Loading from a History Module</b></p>	<p>Action: Select: <span style="border: 1px solid black; padding: 2px 10px;">LOAD</span></p> <p>Response: <span style="border: 1px solid black; padding: 2px 10px;">DEFAULT SOURCE</span> OR <span style="border: 1px solid black; padding: 2px 10px;">ALTERNATE SOURCE</span></p> <p>Action: Select: <span style="border: 1px solid black; padding: 2px 10px;">DEFAULT SOURCE</span> + <span style="border: 1px solid black; padding: 2px 10px;">EXECUTE COMMAND</span></p> <p>Response: Process Module detail display with sequence name appears on the screen</p> <p>Action: Select: <span style="border: 1px solid black; padding: 2px 10px;">SEQUENCE NAME</span> + <span style="border: 1px solid black; padding: 2px 10px;">START</span></p> <p>Response: Loading begins</p>
<p><b>Loading from an Alternate Source</b></p>	<p>Action: Select: <span style="border: 1px solid black; padding: 2px 10px;">LOAD</span></p> <p>Response: <span style="border: 1px solid black; padding: 2px 10px;">DEFAULT SOURCE</span> OR <span style="border: 1px solid black; padding: 2px 10px;">ALTERNATE SOURCE</span></p> <p>Action: Select: <span style="border: 1px solid black; padding: 2px 10px;">ALTERNATE SOURCE</span></p> <p>Response: Display appears to make appropriate drive selections</p> <p>Action: Select drive 1, 2, 3, etc. depending on which one has the floppy or cartridge</p> <p>Response: Process Module detail display appears on the screen</p> <p>Action: Select: <span style="border: 1px solid black; padding: 2px 10px;">SEQUENCE NAME</span> + <span style="border: 1px solid black; padding: 2px 10px;">START</span></p> <p>Response: Loading begins</p>

# SEQUENCE OPERATIONS, continued

## Save a Sequence Program

<b>Saving from a Process Module Display</b>	<p>Action: Select: <input type="button" value="LOAD SAVE"/></p> <p>Response: Save target appears on the screen</p>
<b>Saving using a History Module</b>	<p>Action: Select: <input type="button" value="SAVE"/></p> <p>Response: <input type="button" value="DEFAULT SOURCE"/> OR <input type="button" value="ALTERNATE SOURCE"/></p> <p>Action: Select: <input type="button" value="DEFAULT SOURCE"/> + <input type="button" value="EXECUTE COMMAND"/></p> <p>Response: Process Module detail display with sequence name appears on the screen</p> <p>Action: Select: <input type="button" value="START"/></p> <p>Response: Saving begins</p>
<b>Saving using an Alternate Source</b>	<p>Action: Select: <input type="button" value="SAVE"/></p> <p>Response: <input type="button" value="DEFAULT SOURCE"/> OR <input type="button" value="ALTERNATE SOURCE"/></p> <p>Action: Select: <input type="button" value="ALTERNATE SOURCE"/></p> <p>Response: Display appears to make appropriate drive selections</p> <p>Action: Select drive 1, 2, 3, etc. depending on which one has the floppy or cartridge</p> <p>Response: Process Module detail display appears on the screen</p> <p>Action: Select: <input type="button" value="START"/></p> <p>Response: Saving begins</p>

# SEQUENCE OPERATIONS, continued

## Change Module Operating State

Call up from a Process Module Group or Detail Display

Action: Select: **MODULE STATE** Under OPER column

Response: The following targets appear allowing you to change a Process Module Operating state

- Action: Select:
- READY** to put sequence in READY state (MC, PM, & APM)
  - OFF** to set module state to OFF
  - EMSD** to initiate the Emergency Shutdown Handler (if enabled)
  - SHUT DOWN** to initiate the Shutdown Handler (if enabled)
  - HOLD** to initiate the Abnormal Condition Handler (if enabled)
  - RESTART** to restart the sequence when in a HOLD or SHDN state (MC, PM, & APM)





Response: Process Module Operating State will change once enter is selected

Action: Select: **ENTER** OR **ENTER**







Response: Process Module Operating state changes

## SEQUENCE OPERATIONS, continued

### Change Sequence Execution State







<b>Change the Execution State from a Process Module Group or Detail Display</b>	<p>Action: Select:  Under EXEC column</p> <p>Response: The following targets appear allowing you to change the Execution state</p> <p>Action: Select:  to start the sequence</p> <p> to stop the sequence</p> <p>Response: Execution State will change only if sequence program is loaded and ENTER is selected</p> <p>Action: Select:  OR </p> <p>Response: Execution State changes</p>
---	---

### Change Sequence Execution Mode

<b>Change the Sequence Mode from a Process Module Group or Detail Display</b>	<p>Action: Select:  under MODE column</p> <p>Response: The following targets appear allowing you to change the Execution Mode</p> <p>Action: Select:  to put the sequence in AUTO mode</p> <p> to put the sequence in SEMI-AUTO mode</p> <p> to put the sequence in SINGLE-STEP mode</p> <p>Response: Execution mode will change once enter is selected</p> <p>Action: Select:  OR </p> <p>Response: Execution Mode changes</p>
---	--

## SEQUENCE OPERATIONS, continued

### Select Sequence Override

<b>Select Sequence Override</b>	<p>Action: Select one of the following targets</p> <p> under PHASE column</p> <p> under STEP column</p> <p> Statement Number near top center of Process Module Detail Display</p> <p>Response: The following targets appear allowing you to change the Phase/Step/Statement</p> <p>Action: Select:  to go to next Phase/Step/Statement</p> <p> to go to previous Phase/Step/Statement</p> <p>Response: Phase/Step/Statement changes forwards or backwards once enter is selected</p> <p>Action: Select:  OR </p> <p>Response: Phase/Step/Statement changes</p>
---------------------------------	---







**Note:** Sequence Override can be performed for the MC only if the Execution State is ERxx/FAxx, or the Operating State is READY; for the PM, the Execution State must be Exxx/Fxxx, or the Operating State OFF.

# ALARM FUNCTIONS

## Silence the Horn



<b>Silence the horn from any display</b>	Action: Select:  Response: Alarm horn stops
--	---

## Acknowledge Local Console Alarms



<b>Acknowledge all US alarms</b>	Action: Select:  Response: Console Status display appears on the screen Action: Select:  Response: Acknowledges all US alarms
<b>Acknowledge PERIPHS OR MAINT alarms</b>	Action: Select:  Response: Console Status display appears on the screen Action: Select:  Response: Station number becomes highlighted Action: Select:  OR  Response: The corresponding display appears on the screen Action: Select:  Response: Peripheral Status or Maintenance Information alarms become acknowledged and stop blinking





## ALARM FUNCTIONS, continued

### Acknowledge System Alarms

<b>Acknowledge all System Status alarms</b>	Action: Select:  Response: System Status display appears on the screen Action: Select:  Response: System Status alarms become acknowledged
---	---

### Acknowledge Process Network (Hiway/UCN) Alarms

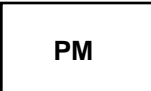
<b>Acknowledge all Process Network alarms</b>	Action: Select:  Response: System Status display appears on the screen Action: Select one of the NIM or HG node object boxes. Response: The node object box is backlit. Action: Select the  target. Response: The Process Networks Node Status display appears on the screen Action: Select:  Response: Hiway/UCN and Process-Connected Device alarms become acknowledged
---	--

<b>Call up detailed information for a PM and Hiway devices</b>	Action: Select:  for Hiway devices Response: Text box appears Action: Type in box address 1-63 +  Response: Detail page of the box appears on the screen Action: Select:  +  Response: Detail page of the PM appears on the screen
--	--







## ALARM FUNCTIONS, continued

### Lost Event (Alarm) Recovery

*At the Alarm Annunciator Display, Area or Unit Alarm Summary Displays, or from System Status Display with a blinking EVENT RECOVERY target:*

<b>Call up lost events</b>	Action: Select:  Response: All lost events are notified Action: Select:  Response: All lost events are recovered
----------------------------	---

### Acknowledge Process Alarms



<b>Acknowledge from the Area Alarm summary display</b>	Action: Select:  Response: Alarm Summary display appears on the screen Action: Select:  Response: All Process Alarms on that display become acknowledged
<b>Acknowledge from the Alarm Annunciator display</b>	Action: Select:  Response: Alarm Annunciator display appears on the screen Action: Select:  Response: All emergency priority alarms on that display become acknowledged
<b>Acknowledge from the Unit Alarm summary</b>	Action: Select:  Response: Text box appears on the left side of the screen Action: Type in unit ID Response: Page one of the Unit Alarm summary display appears on the screen Action: Select:  Response: All Unit alarms for the display page become acknowledged

## ALARM FUNCTIONS, continued



### Acknowledge Process Alarms (continued)

<b>Call up Unit Alarms from any process alarm display</b>	Action: Select:  Response: Unit Alarm Summary is called up
---	--

### Acknowledge Messages

<b>Acknowledge Messages</b>	Action: Select:  Response: Message Summary display appears on the screen Action: Select:  Response: All Messages on that page become acknowledged. Use the page forward and page backward keys to go through all pages on the Message Summary display.
-----------------------------	---

### Confirm and Clear Messages

<b>Confirm Messages</b>	Action: Select:  Response: Message Summary display appears on the screen Action: Select:  to confirm the message (Message must be acknowledged before confirmation).  to clear all acknowledged and confirmed messages on the page Response: Depending on selection, messages become clear or confirmed
-------------------------	--

# INITIAL LOAD OF US FROM CARTRIDGE



*Load with no US running and with no HM with US personality and area database available. This procedure is for an initial, one-time load of the TDC 3000<sup>X</sup>. For subsequent loads, use other load procedures.*

## Initial load from cartridge disk

Action: Check for the prompt ">" at the US. If not present, RESET  press under the hinged keyboard cover and wait for the ">" prompt to appear.

Action: Press: 



Response: Prompt: "N,1,2,3,4,X?"

Action: Select:  +   
Number of Drive



Response: Information will be loaded from cartridge  
Prompt: "OPR, UNP, X?"

Action: Type in OPR, or UNP + 



Response: Selected personality is loaded into your station  
Prompt: "NCF? N,1,2,3,4,X?"

Action: Select:  +   
Number of Drive



Response: NCF is loaded into your station  
Prompt: "ARnn N,1,2,3,4,X?"

Action: Select:  +   
Number of Drive

Response: Area database is loaded into your station  
Prompt: "ABST N,1,2,3,4,X?"

Action: Select:  +   
Number of Drive

Response: Abstracts are loaded into your station  
Prompt: "BUTT N,1,2,3,4,X?"

Action: Select:  +   
Number of Drive

Response: Button database is loaded. Station is now loaded

# LOAD UNIVERSAL STATION FROM THE HISTORY MODULE

*This procedure loads a US from an HM.*

## Loading from the Network

Action: Check for the prompt ">" at the US. If not present,  
**RESET**  press under the hinged keyboard cover  
and wait for the ">" prompt to appear.

Action: Press: 

Response: **Prompt** "N,1,2,3,4,X?"

Action: Press the <ALPHA SHIFT> key.

Response: the key's red light appears.

Action: Press:  + 

Response: Information will be loaded from Network

**Prompt** "OPR, UNP, X?"

Action: Type in OPR or UNP + 

Response: Selected personality is loaded from the Network into your station. Messages come up that the station is being loaded. Depending on the personality chosen, a display appears when the station is loaded.

# LOAD A US FROM ANOTHER US IN THE CONSOLE



## Load Operator or Universal Personality

*There are two methods of loading a US from another US on the same console.*

*Note: The US must be in the FAIL, PWR\_ON, or WARNING state.*

---





**METHOD A: This method allows the user to choose loading from network or removable media, manually or automatically.**

1.  OR  at a Universal Station, OR select a US node object box on the System Status display then select the [NODE STATUS] target.

The Console Status and Assignment display appears.

2.  select from the display the US to be loaded.

-  Then select the Load/Dump target.  
Four hidden targets appear.

3.     select load type (But not Dump Node)

**AUTOLOAD NET**—Select and press ENTER. Loads the target US from the Network. (No other steps.)

**AUTOLOAD LOCAL**—Select and press ENTER. Loads the target US from removable media or Network. (See step 5.)

**MANUAL LOAD**—Select and press ENTER. Select the personality type, and load from Network or removable media. (See step 4.)

4.  OR  select a Personality for loading
-

## LOAD A US FROM ANOTHER US IN THE CONSOLE, continued

---

5. Select program load source:



OR

Insert the removable medium with Operator or Universal Personality #1(&C1/&C2) into drive 1 or 2 and select:

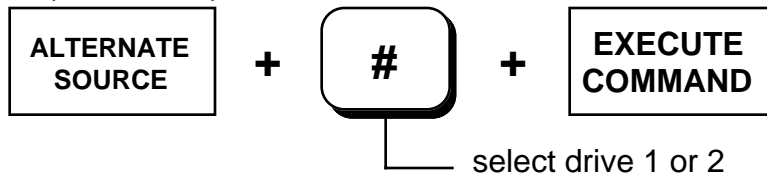

6. Select data load source:



OR

Insert the removable medium with your NCF (&ASY) into drive 1 or 2 and select:

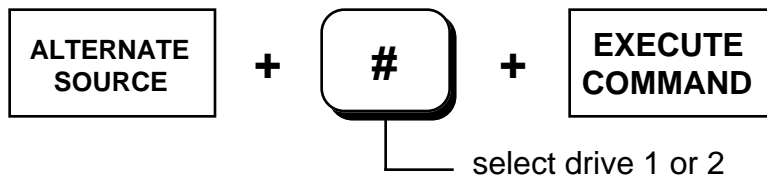

7. **ENTER** to begin loading.

*The SystemStatus Display appears.*



---

## LOAD A US FROM ANOTHER US IN THE CONSOLE, continued

***METHOD B: This method automatically loads the US from the network.***

---

Insert the removable medium with Engineer Personality #2 (&ENG) into drive 1 or 2 and select:

1.  at a Universal Station
2. Select the node object box of the US to be loaded.
3.  +  The US loads from the network.

***The Universal Station status changes to “OK” on the System and Console Status Displays.***



---

## LOAD UNIVERSAL STATION FROM A FAST LOAD CARTRIDGE

*This procedure is intended for use in the event of a complete TDC 3000<sup>X</sup> system shutdown. A specially prepared cartridge disk is required—see the Engineer's Reference Manual, subsection, Node Loading and Node Dumps.*

---

### Fast Load from cartridge disk

1.  Press the **LOAD** button at the Universal Station. The "N,1,2,3,4,X?" prompt appears.
2. Insert a Fast Load Cartridge (Section 20 of the Engineer's Reference Manual) in either drive 1 or 2.
3. **RESET**  Press the **RESET** button at the Universal Station and wait for the ">" prompt to appear.
4. Select the drive you are using by entering either "1" or "2", then press



**ENTER**

Personality load begins.

If there is only one personality loaded on the cartridge, the personality will automatically load.

If there is more than one personality on the cartridge, go to the next step.

5. "OPR, UNP?" If both personalities are on the cartridge, this prompt appears. Key in your choice of either "U" for Universal Personality or "O" for Operator Personality. Press ENTER.

***The SystemStatus Display appears. Loading of the US is complete. If you need to use this cartridge to reestablish a "path to the valve," continue with the next step.***

6. On the Operator's Keyboard select <SYST STATS>. The System Status display appears.
-

## LOAD A US FROM A FAST LOAD CARTRIDGE, continued







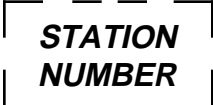

---

- |  |  |
|--|--|
| 7. On the System Status display, select a NIM or HG node object box. | The node object box is backlit.  |
| 8. Select the [LOAD SELECT] target and press [ENTER].                | The NIM or HG and the nodes on the associated process network are loaded. When loading is complete, the NIM or HG status changes to OK. You can now resume control of the points on the process network. |
-

## LOAD UNIVERSAL STATION USING CARTRIDGES

*This procedure loads a US from removable media.*

*Note: The US must be in the FAIL, PWR\_ON, or WARNING state.*

<b>Load a US from removable media</b>	<p>Action: Select: </p> <p>Response: The Console Status display is called up</p> <p>Action: Select: </p> <p>Response: Universal Station to be loaded is selected</p> <p>Action: Select: </p> <p>Response: The following target appears</p> <p>Action: Select:  </p> <p>Response: The following targets appear</p> <p>Action: Select: </p> <p>Response: Drive targets appear</p> <p>Action: Select: Drive number 1, 2, 3, etc. + </p> <p>Response: The following target appears</p> <p>Action: Select: </p> <p>Response: Drive targets appear</p> <p>Action: Select: Drive number 1, 2, 3, etc. + </p> <p>Response: Prompt: PRESS ENTER TO EXECUTE</p> <p>Action: Select: </p> <p>Response: Station begins loading</p>
---------------------------------------	---

# LOAD A PERSONALITY FROM A CARTRIDGE

## Load Universal or Operator Personality

*This procedure loads a personality onto a US from a cartridge.*

1. **RESET**  Press the **RESET** button at the Universal Station and wait for the ">" prompt to appear.

2.  Press the **LOAD** button at the Universal Station. The "**N,1,2,3,4,X?**" prompt appears.





(or type <LOAD> on the Universal Work Station Engineering Keyboard ).

3. Insert &C1/C2 cartridge in drive 1 and select:



Prompt: "**UNP,OPR?**"

This prompt only appears if both personalities are on the cartridge; otherwise, the one residing personality is loaded automatically.

4.  +  OR  + 

The "**NCF? N,1,2,3,4,X?**" prompt appears.

5. Insert the cartridge with your NCF (&ASY) into drive 2.

6.  + 

*System Status display appears.*

or, for the Universal personality:



*Engineer Main Menu appears.*





# SYSTEM STATUS COMMANDS

## Call Up System Status Display

<b>Call up System Status display</b>	Action: Press:  Response: System Status display appears on the screen
--------------------------------------	---





## Change System Time and Date

From the System Status display, perform the following.









<b>Change System time and date</b>	Action: Select:  Response: The prompt "ENTER TIME" appears with text box allowing you to type in time. Action: Type in Hours (00 - 23)  Minutes (00 - 59) +  Response: The prompt "ENTER DATE" appears with text box allowing you to type in date. Action: Type in Days (00 - 31)  Month (JAN, FEB, ...) +  Response: The time and date entry appears in the upper right corner of the display.
------------------------------------	--

# CONSOLE STATUS COMMANDS

## Call Up Console Status and Assignment Display

<b>Call up Console Status display</b>	Action: Press:  Response: Console Status display appears on the screen Action: Press:  +  +  Response: Remote Console Status display appears on the screen
---------------------------------------	--

## Display/Change Unit Status

<b>Change Unit status</b>	Action: Select:  Response: Unit Assignment display is called up Action: Select:  Response: Unit is selected Action: Select: YES or NO to enable or disable operator control on the selected unit <b>UNIT ASSIGNMENT</b>   <b>OR</b> Action: Select one of the following targets  to enable full alarming on the system alarm state  to disable alarm annunciation and displays for the system alarm state  to inhibit all alarming on the system alarm state, including journaling  to enable full alarming on the console alarm state  to disable alarm annunciation and displays for the console alarm state Response: Depending on target selected, different actions occur
---------------------------	---

# CONSOLE STATUS COMMANDS, continued

## Area Change

<b>Make an area change</b>	<p>Action: Select: <b>STATION NUMBER</b></p> <p>Response: Station Number turns white</p> <p>Action: Select: <b>AREA CHANGE</b></p> <p>Response: Area change display appears on the screen</p> <p>Action: Select: <b>AREA NUMBER</b></p> <p style="text-align: center;">+</p> <p style="text-align: center;"><b>DEFAULT SOURCE</b></p> <p style="text-align: right;">To load from the Network</p> <p style="text-align: center;">OR</p> <p><b>ALTERNATE SOURCE</b> + <b>DRIVE NUMBER</b> To load from Cartridge Drive</p> <p style="text-align: center;">+</p> <p style="text-align: center;"><b>EXECUTE COMMAND</b></p> <p>Response: Area change occurs</p>
----------------------------	---

## Change Printer Assignment

<b>Change printer assignment</b>	<p>Action: Select: <b>PRTR ASSIGN</b></p> <p>Response: Prompt ENTER ASSIGNMENT</p> <p>Action: Select: <b>PRTR No.</b> and type assignment number</p> <p>Action: Select: <b>ENTER</b></p> <p>Response: Printer assignment is changed</p>
----------------------------------	---

## CONSOLE STATUS COMMANDS, continued

### View Peripheral Status Maintenance Information





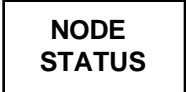

<b>View Peripheral status</b>	Action: Select: <table border="1" data-bbox="743 310 1105 394"><tr><td>STATION</td></tr><tr><td>NUMBER</td></tr></table> + <table border="1" data-bbox="959 310 1105 394"><tr><td>PERIPH</td></tr><tr><td>STATUS</td></tr></table> Response: Peripheral status appears on the screen	STATION	NUMBER	PERIPH	STATUS
STATION					
NUMBER					
PERIPH					
STATUS					
<b>View Maintenance Information</b>	Action: Select: <table border="1" data-bbox="743 489 899 573"><tr><td>STATION</td></tr><tr><td>NUMBER</td></tr></table> + <table border="1" data-bbox="959 489 1105 573"><tr><td>MAINT</td></tr><tr><td>INFO</td></tr></table> Response: Maintenance information appears on the screen	STATION	NUMBER	MAINT	INFO
STATION					
NUMBER					
MAINT					
INFO					

# SYSTEM STATUS COMMANDS

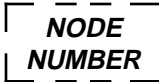



## Call Up System and Module Status Displays

<p><b>Call up system and module status displays</b></p>	<p>Action: Select: </p> <p>Response: System status display appears on the screen</p> <p>Action: Select one of the node object boxes, then select</p> <div style="text-align: center;">  </div> <p>Response: The selected node's corresponding node status display appears.</p>
---	--

## Enable/Disable Node Auto Loads and Dumps

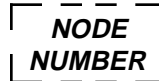
<p><b>Enable/Disable auto loads and dumps</b></p>	<p>Action: Select:  on the node status display.</p> <p>Response: Node number becomes highlighted</p> <p>Action: Select: </p> <p>Response: Prompt: MAKE SELECTION</p> <p>Action: Select:     </p> <p>Response: Function is activated, current load state line shows change</p>
---	---

## Shut Down a Node

<p><b>Shut down a node</b></p>	<p>Action: Select:  on the node status display.</p> <p>Response: Node number becomes highlighted</p> <p>Action: Select:  + </p> <p>Response: Node shuts down</p> <p> Key may be required before node will shut down</p>
--------------------------------	--

# SYSTEM STATUS COMMANDS, continued

## Swap LCN Cables

Swap cables	Action: Select:	<input type="text" value="CABLE A"/>	+	<input type="text" value="ENTER"/>
	Response:	Cable B swaps to Cable A		
	Action: Select:	<input type="text" value="CABLE B"/>	+	<input type="text" value="ENTER"/>
	Response:	Cable A swaps to Cable B		

## Load a NIM, HG, AM, HM, or CM50

**NOTE: The node must be in the "PWR\_ON" or "QUALIF" state. Press RESET at the node or execute a SHUTDOWN to get the node in the proper state.**

Load a NIM, HG, AM, HM, or CM60	Action: Select node number on the node status display	<input type="text" value="NODE NUMBER"/>
	Response:	The following target appears
	Action: Select:	<input type="text" value="MAN LOAD"/>
	Response:	The following target appears
	Action: Select:	<input type="text" value="OPERATOR PROGRAM"/>
	Response:	Targets appear to specify <b>program</b> load source
	Action: Select:	<input type="text" value="DEFAULT SOURCE"/> to load from the Network
		<input type="text" value="ALTERNATE SOURCE"/> to load from Floppy or Cartridge drive number must be specified
		+
		<input type="text" value="EXECUTE COMMAND"/>
	Response:	Targets appear to specify <b>data</b> load source
	Action: Select:	<input type="text" value="DEFAULT SOURCE"/> to load from the Network
		<input type="text" value="ALTERNATE SOURCE"/> to load from Floppy or Cartridge drive number must be specified
		+
	<input type="text" value="EXECUTE COMMAND"/>	
Response:	Node loads and status changes to OK	

## SYSTEM STATUS COMMANDS, continued

### Display Units Controlled by AM or CM

<b>Display units controlled by AM or CM</b>	Action: Select node number on the node status display <div style="text-align: center;"><input type="text" value="NODE"/> <input type="text" value="NUMBER"/></div> Response: The following target appears Action: Select: <input type="button" value="UNIT CONTROL"/> Response: Units controlled by AM or CM are displayed on the screen
---	---

### Enable/Disable History Collection on an HM



<b>Enable or disable History Module collection</b>	Action: Select node number on the node status display <div style="text-align: center;"><input type="text" value="NODE"/> <input type="text" value="NUMBER"/></div> Response: The following target appears Action: Select: <input type="button" value="HIST COLLECT"/> Response: The following targets appear Action: Select: <input type="button" value="ENABLE COLLECT"/> <input type="button" value="DISABLE COLLECT"/> Response: Depending on target selected, History Module collection is enabled or disabled
--	---

### Enable/Disable HG - Hiway Alarming

<b>Enable or disable Hiway alarming</b>	Action: Select node number on the node status display <div style="text-align: center;"><input type="text" value="NODE"/> <input type="text" value="NUMBER"/></div> Response: The following target appears Action: Select: <input type="button" value="HWY ALRM ENB/DSB"/> Response: The following targets appear Action: Select: <input type="button" value="ENABLE"/> <input type="button" value="DISABLE"/> Response: Depending on target selected, Hiway Alarming is enabled or disabled
---	--

# HIWAY STATUS COMMANDS

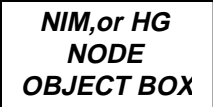
## Call up Hiway Status Display

<b>Call up the Hiway Status display</b>	<p>Action: Select: </p> <p>Response: The system status display appears</p> <p>Action: Select:  (for Hiway).</p> <p>Response: Network node becomes highlighted</p> <p>Action: Select: </p> <p>Response: Process Networks Node Status Display appears</p> <p>Action: Select: </p> <p>Response: Hiway Status display appears</p>
---	---

## Display Box Descriptors on Hiway Status Display

<b>Display box descriptors at the Hiway status display</b>	<p>Action: Select: </p> <p>Response: Box descriptors appear on the left side of the screen</p>
--	---

## HIWAY STATUS COMMANDS, continued

### Load Trend Memory Program (Basic Controller)

<b>Load Trend Memory program</b>	<p>Action: Select: <b>TREND MEMORY</b></p> <p>Response: Text box appears</p> <p>Action: Type in box number or select</p> <p><b>ALL BOXES</b> + <b>ENTER</b></p> <p>Response: Targets appear to specify load source</p> <p>Action: Select: <b>DEFAULT SOURCE</b> to load from the Network</p> <p><b>ALTERNATE SOURCE</b> to load from Floppy or Cartridge drive number must be specified</p> <p>+ <b>EXECUTE COMMAND</b></p> <p><b>OVERWRITE</b> (optional) to overwrite the currently running program</p> <p><b>START FUNCTION</b> to begin loading the program</p> <p>Response: Program begins loading</p>
----------------------------------	---

### Swap Hiway Cables

<b>Swap Hiway cables</b>	<p>Action: Select: <b>HIWAY CMND</b></p> <p>Response: The following target appears</p> <p>Action: Select: <b>SWAP HIWAY</b> + <b>EXECUTE COMMAND</b></p> <p>Response: Hiway cables swap</p>
--------------------------	---

### Initialize Box Address

<b>Initialize box address</b>	<p>Action: Select: <b>HIWAY CMND</b></p> <p>Response: The following target appears</p> <p>Action: Select: <b>INIT ADDR</b> + <b>EXECUTE COMMAND</b></p> <p>Response: Box address becomes initialized</p>
-------------------------------	--

## HIWAY STATUS COMMANDS, continued

### Enable/Disable all Hiway Swaps

<b>Enable or disable all Hiway swaps</b>	<p>Action: Select: <span style="border: 1px solid black; padding: 2px;">HIWAY CMND</span></p> <p>Response: The following targets appear</p> <p>Action: Select: <span style="border: 1px solid black; padding: 2px;">ENABLE SWAP</span> OR <span style="border: 1px solid black; padding: 2px;">DISABL SWAP</span> + <span style="border: 1px solid black; padding: 2px;">EXECUTE COMMAND</span></p> <p>Response: Depending on target selection, all Hiway swaps are enabled or disabled</p>
--	---

### Enable/Disable Periodic Hiway Swaps

<b>Enable or disable periodic Hiway swaps</b>	<p>Action: Select: <span style="border: 1px solid black; padding: 2px;">HIWAY CMND</span></p> <p>Response: The following target appears</p> <p>Action: Select: <span style="border: 1px solid black; padding: 2px;">ENABLE PERIOD</span> OR <span style="border: 1px solid black; padding: 2px;">DISABL PERIOD</span> + <span style="border: 1px solid black; padding: 2px;">EXECUTE COMMAND</span></p> <p>Response: Depending on target selection, periodic Hiway swaps are enabled or disabled</p>
---	--

### Change Hiway or Box Control State (without an HTD)

*(Note: This is not an option when a Hiway Traffic Director (HTD) is included.)*

<b>Change Hiway or Box control state</b>	<p>Action: Select: <span style="border: 1px solid black; padding: 2px;">HIWAY CMND</span> OR <span style="border: 1px solid black; padding: 2px;">BOX CMND</span> Type in box number</p> <p>Response: The following targets appear</p> <p>Action: Select:</p> <div style="display: flex; justify-content: center; align-items: center; gap: 10px;"> <div style="border: 1px solid black; padding: 2px;">BASIC CTRL</div> <div style="border: 1px solid black; padding: 2px;">READ CTRL</div> <div style="border: 1px solid black; padding: 2px;">FULL CTRL</div> <div style="border: 1px solid black; padding: 2px;">TEST CTRL</div> </div> <p style="text-align: center;">+</p> <div style="border: 1px solid black; padding: 2px; margin: 0 auto; width: fit-content;">EXECUTE COMMAND</div> <p>Response: Depending on target selection, Hiway or Box control state changes</p>
--	---

# HIWAY STATUS COMMANDS, continued

## Enable/Disable Hiway Checkpointing

<b>Enable or disable Hiway checkpointing</b>	Action: Select: <input type="text" value="HIWAY CMND"/> Response: The following targets appear Action: Select: <input type="text" value="CKPT ENABLE"/> OR <input type="text" value="CKPT DISABL"/> Response: Depending on target selection, Hiway checkpointing is enabled or disabled
--	--

## Box Commands

<b>Execute a box command</b>	Action: Select: <input type="text" value="BOX CMND"/> OR <input type="text" value="BOX STATUS"/> Type in box number <input type="text" value="ENTER"/>  Response: The following targets appear Action: Select one of the following targets <input type="text" value="START"/> to restart a CB, EC, MC, RCD, DHP, or PIU <input type="text" value="ENABLE PROC"/> <input type="text" value="IDLE"/> to change MC state from processing to idle <input type="text" value="ACK"/> to clear PIU or DHP processing overload and A/D offset errors <input type="text" value="CONFIG CLEAR"/> to clear the DHP database and reset the DHP + <input type="text" value="EXECUTE COMMAND"/>  Response: Depending on target selection, Box command is executed
------------------------------	--

# HIWAY STATUS COMMANDS, continued

## Box Commands (RCD)

<b>Execute an RCD Box command</b>	Action: Select: <input type="text" value="BOX CMND"/> OR <input type="text" value="BOX STATUS"/> Type in box number
	Response: The following targets appear
	Action: Select one of the following targets
	<input type="text" value="START RC"/> to restart the reserve controller in a UAC system
	<input type="text" value="SWBACK PRI"/> to cause the RCD to switch back to the primary
	<input type="text" value="START PRI"/> to restart the primary controller in a UAC system
	<input type="text" value="TEST PRI"/> to do a test backup of a primary controller in a UAC system
	<input type="text" value="SAVE PRI"/> to force a backup of a primary controller in a UAC system
	<input type="text" value="DISABL PRI"/> to disable a primary controller in a UAC system
	<input type="text" value="ENABLE PRI"/> to enable a primary controller in a UAC system
<b>+</b>	
<input type="text" value="EXECUTE COMMAND"/>	
Response: Depending on target selection, RCD Box command is executed	

# UCN STATUS COMMANDS

## Call up UCN Status Display

### Call up the UCN Status display

Action: Select: 

Response: The system status display appears

Action: Select:  (For UCN).

Response: Node object box becomes highlighted

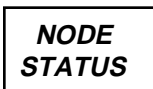
Action: Select: 

Response: UCN Status Display appears

OR

Action: Select: 

Response: The system status display appears

Action: Select:  (For UCN).

Response: Node object box becomes highlighted

Action: Select: 

Response: UCN Status Display appears

# UCN STATUS COMMANDS, continued

## Change UCN or PM Control State

<b>Change UCN control states</b>	<p>Action: Select: <b>CONTROL STATES</b> from the UCN Status display</p> <p>Response: The following targets appear</p> <p>Action: Select: <b>UCN FULL CONTROL</b> OR <b>UCN BASIC CONTROL</b> + <b>ENTER</b></p> <p>Response: UCN control state changes to full or basic</p>
<b>Change PM control states</b>	<p>Action: Select: <b>CONTROL STATES</b> from the UCN Status display</p> <p>Response: The following targets appear</p> <p>Action: Select: <b>DEV FULL CONTROL</b> OR <b>DEV BASIC CONTROL</b></p> <p>Response: The following targets appear</p> <p>Action: Select: <b>Specific PM</b> OR <b>ALL DEVICES</b> + <b>ENTER</b></p> <p>Response: PM control state changes to full or basic</p>

## UCN STATUS COMMANDS, continued

### Enable/Inhibit Automatic Checkpointing

<b>Enable or inhibit UCN and device automatic checkpointing</b>	<p>Action: Select: <b>AUTO CHECKPT</b> from the UCN Status display</p> <p>Response: The following target appears</p> <p>Action: Select: <b>UCN CKPT ENABLE</b> OR <b>UCN CKPT INHIBIT</b> + <b>ENTER</b></p> <p>Response: UCN checkpointing is enabled or inhibited</p> <p>Action: Select: <b>DEV CKPT ENABLE</b> OR <b>DEV CKPT INHIBIT</b> + <b>ENTER</b></p> <p>Response: UCN device checkpointing is enabled or inhibited</p> <p>Action: Select: <b>CONTROL STATES</b></p> <p>Response: The following targets appear</p> <p>Action: Select: <b>DEV FULL CONTROL</b> OR <b>DEV BASIC CONTROL</b></p> <p>Response: The following targets appear</p> <p>Action: Select: <b>Specific PM</b> OR <b>ALL DEVICES</b> + <b>ENTER</b></p> <p>Response: UCN and device auto checkpointing is enabled or inhibited</p>
---	---

### Select UCN Cable

<b>Select UCN cables</b>	<p>Action: Select: <b>UCN CABLE STATUS</b> from the UCN Status display</p> <p>Response: The following targets appear</p> <p>Action: Select: <b>SELECT CABLE A</b> OR <b>SELECT CABLE B</b></p> <p>Response: The following targets appear</p> <p>Action: Select: <b>ALL NODES</b> OR <b>Specific PM</b> + <b>ENTER</b></p> <p>[Note warning on screen]</p> <p>Response: Cable selection changes for all nodes or a specific PM</p>
--------------------------	---

## UCN STATUS COMMANDS, continued

### Enable/Disable Automatic UCN Cable Swaps

<b>Enable or disable automatic UCN cable swaps</b>	<p>Action: Select: <b>UCN CABLE STATUS</b> from the UCN Status display</p> <p>Response: The following targets appear</p> <p>Action: Select: <b>ALL NODES</b> OR <b>Specific PM</b></p> <p>Response: The following targets appear</p> <p>Action: Select: <b>ENABLE SWAP</b> OR <b>DISABLE SWAP</b> + <b>ENTER</b></p> <p>Response: Automatic cable swapping is enabled or disabled</p>
--	---

### Idle a PM or APM

<b>Idle a PM or APM</b>	<p>Action: Select: <b>RUN STATES</b> + <b>Specific PM</b> from the UCN Status display</p> <p>Response: The following targets appear</p> <p>Action: Select: <b>IDLE</b> + <b>ENTER</b></p> <p>Response: The PM or APM is idled</p>
-------------------------	---

### Start up a PM or APM

<b>Start up a PM or APM</b>	<p>Action: Select: <b>RUN STATES</b> + <b>Specific PM</b> from the UCN Status display</p> <p>Response: The following target appears</p> <p>Action: Select: <b>STARTUP</b></p> <p>Response: The following targets appear</p> <p>Action: Select: <b>WARM STARTUP</b> OR <b>COLD STARTUP</b> + <b>ENTER</b></p> <p>Response: The PM or APM is started</p>
-----------------------------	--

## UCN STATUS COMMANDS, continued

### Idle or Shut Down a PMM, APMM, or I/O Processor

<p><b>Shut down or idle a PMM, APMM, or I/O processor</b></p>	<p>Action: Select: <input type="text" value="Specific PM or APM"/> + <input type="text" value="DETAIL STATUS"/> from the UCN Status display</p> <p>Response: The detail display for a specific PM appears on the screen</p> <p>Action: Select: <input type="text" value="RUN STATES"/> + <input type="text" value="Specific Device"/></p> <p>Response: The following targets appear</p> <p>Action: Select: <input type="text" value="IDLE"/> OR <input type="text" value="SHUTDOWN"/> + <input type="text" value="ENTER"/></p> <p>Response: The PM or I/O is shut down or becomes idled</p> <p><i>NOTE: The device must be in IDLE before it can be shut down</i></p>
---	---

### Swap PMMs or APMMs

<p><b>Swap PMMs</b></p>	<p>Action: Select: <input type="text" value="Specific PM or APM"/> + <input type="text" value="DETAIL STATUS"/> from the UCN Status display</p> <p>Response: The detail display for a specific PM appears on the screen</p> <p>Action: Select: <input type="text" value="RUN STATES"/> + <input type="text" value="PMM"/></p> <p>Response: The following targets appear</p> <p>Action: Select: <input type="text" value="SWAP PRIMARY"/> + <input type="text" value="ENTER"/></p> <p>Response: The PMs swap</p>
-------------------------	---

# DATABASE SAVE (CHECKPOINT) FUNCTIONS

## Save AM or CM Control Database

### Save AM or CM control database

Action: Select: 



Response: The system status display appears.

Action: Select: 

Response: Node object box becomes highlighted.

Action: Select: 

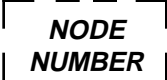
Response: The application or communication module display appears on the screen

Action: Select:  + 

Response: The following targets appear

Action: Select:  To load from the Network

 + 







+

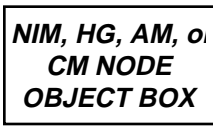

Response: The database for the AM or CM is saved

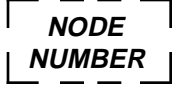









## DATABASE SAVE (CHECKPOINT) FUNCTIONS, continued

### Enable/Disable Auto Save for NIM, HG, AM, or CM

<b>Enable or disable auto save for the NIM, HG, AM, or CM</b>	<p>Action: Select: </p> <p>Response: The system status display appears</p> <p>Action: Select: </p> <p>Response: Node object box becomes highlighted</p> <p>Action: Select: </p> <p>Response: The application, communication, or process network display appears on the screen</p> <p>Action: Select:  + </p> <p>Response: The following targets appear</p> <p>Action: Select:  OR </p> <p>Response: Auto save is enabled or disabled for the NIM, AM, HG, or CM</p>
---	--

# DATABASE SAVE (CHECKPOINT) FUNCTIONS, continued

## Save or Load Box Database

<b>Save or load a box database</b>	Action: Select: 
	Response: The System Status display appears
	Action: Select: 
	Response: Node object box becomes highlighted
	Action: Select: 
	Response: Hiway status display appears on the screen
	Action: Select:  OR 
	Response: The following target appears
	Action: Type in box number or select  + 
	Response: The following targets appear
Action: Select:  To load from the Network	
 +  To load from Cartridge Drive	
+ 	
Response: The box database is loaded or saved	

# DATABASE SAVE (CHECKPOINT) FUNCTIONS, continued

## Save or Load PM/NIM/LM/APM Database

Save or load  
PM/NIM/  
LM/APM  
database

Action: Select:



Response: The system status display appears.

Action: Select:

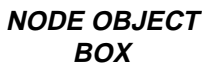

(for UCN node)

Response: Node object box becomes highlighted

Action: Select:



Response: UCN Status Display appears.

Action: Select:

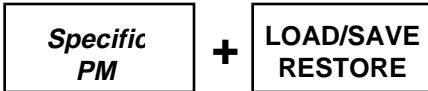

Response: The following targets appear

Action: Select one of the following targets



to load PM program + data  
(PMM "ALIVE")



to restore PM & NIM data  
(PMM "IDLE")



to checkpoint PM & NIM data



to load ladder logic



to checkpoint ladder logic

Response: The following targets appear

Action: Select:



to load from the Network



+



to load from  
Cartridge Drive

+















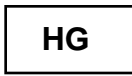

Response: Depending on target selection, data is loaded or saved

# TREND FUNCTIONS

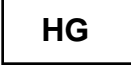
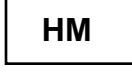
## Group Trend

At an operating Group Display ...

<b>Call up a group trend</b>	<p>Action: Press:  to display preconfigured Group Trend point</p> <p>OR</p> <p> +  to add points to the Trend Display</p> <p>Response: Trend display appears on the screen</p>
<b>Select and change time base</b>	<p>Action: Select:  to select a new time base for the Trend Display</p> <p>Response: The following scrolling targets appear (HM Trends only)</p> <p>Action: Select:  OR </p> <p>Response: Time base changes</p>
<b>Change trend data source</b>	<p><b>Note: HG will not be included for PM Trends</b></p> <p>Action: Select: </p> <p>Response: The following targets appear to the left of the trend graph</p> <p>    </p> <p>Action: Select one of the following targets to change data source for a single trend trace</p> <p>   + </p> <p>Response: The data source changes for a single trace</p> <p>Or</p> <p>Action: Select:  + </p> <p>Response: Change data source for all trend traces</p>

## TREND FUNCTIONS, continued

### Group Trend (continued)

At an operating Group Display ...

<b>Change scale range values</b>	Action: Select: <input type="text" value="100%"/> OR <input type="text" value="0%"/> Response: Prompt appears to enter new high or low scale value Action: Type in new scale value + <input type="button" value="ENTER"/> Response: Scale value changes
<b>Rescale a trace</b>	Action: Select: <input type="text" value="TAGNAME"/> Response: PV scale appears on left side of screen Action: Select: <input type="text" value="HI RANGE"/> OR <input type="text" value="LOW RANGE"/> Action: Type in new scale value + <input type="button" value="ENTER"/> Response: Selected tag name trace is rescaled for greater or lesser detail
<b>Add trace to trend graph</b>	Action: Select: <input type="text" value="TAGNAME"/> of a point not being trended Press <input type="button" value="TREND"/> to add trend trace line of selected point tag Response: Trace added to the trend graph
<b>Delete trace from trend graph</b>	Action: Select: <input type="text" value="TAGNAME"/> of a point being trended Press <input type="button" value="TREND"/> to delete trend trace line from selected point Response: Trace deleted from the trend graph

## TREND FUNCTIONS, continued

### Group Trend (continued)



At an operating Group Display ...

<b>Use scroll time target</b>	<p>Action: Select: <input type="text" value="DATE/TIME"/> at lower right corner of trend graph</p> <p>Response: Date port appears</p> <p>Action: Type in new date + <input type="button" value="ENTER"/></p> <p>Response: Time port appears</p> <p>Action: Type in new time + <input type="button" value="ENTER"/></p> <p>Response: Trend scrolls to requested time and date</p> <p><b>NOTE:</b> By pressing ENTER key without entering value, <b>current</b> date and time are used</p>
<b>Use center-line trending</b>	<p>Action: Select: <input type="button" value="R-AXIS"/> Then select <input type="button" value="C-LINE"/></p> <p>Response: Center-line trend appears, with date and time target, showing values on either side of designated trend time</p> <p><b>NOTE:</b> When requesting a recent time trend, center-line trending will not allow future time to appear; instead, current time appears at the trend's right axis, and the new center-line time is adjusted to half of the time base off current time</p> <p><b>NOTE:</b> C-LINE trending can be used with other trending features</p>
<b>Use hairline trending</b>	<p>Action: Select: <input type="button" value="R-AXIS"/> Then select <input type="button" value="H-LINE"/></p> <p>Response: Hairline trend appears allowing the user to see the numeric data value at the hairline cursor, without going to the System Menu to retrieve history reports for the points trended</p>

## TREND FUNCTIONS, continued



### Group Trend Print

At the Group Trend Display ...

<b>Print and cancel print</b>	Action: Press:	
	Response:	Trend printing is started
	Action: Press:	
	Response:	Trend printing is canceled

### Standard Trend Pen Recording









At an operating Group Display ...

<b>Record and stop recording trends</b>	Action: Press:	
	Response:	LED lights and trend starts recording
	Action: Press:	 again
	Response:	LED turns off and trend stops recording

## TREND FUNCTIONS, continued

### Optional Enhanced Trend Pen Recording

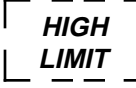
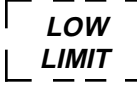
If your system has the optional Enhanced Trend Pen Function:

<p><b>Call up and change an enhanced trend pen record</b></p>	<p>Action: Press: </p> <p>Response: Trend pen display appears and RECRD key LED lights</p>
<p><b>Add/change point/tag assignment</b></p>	<p>Action: Select:  or blank field on line where tag name will appear</p> <p>Response: Prompt ENTER POINT NAME</p> <p>Action: Type in tag name + </p> <p>Response: Display updates to reflect change</p>
<p><b>Delete point/tag assignment</b></p>	<p>Action: Select: </p> <p>Response: Tag name becomes highlighted</p> <p>Action: Type the word <b>NULL</b> + </p> <p>Response: Point is now deleted</p>
<p><b>Change the trended parameter</b></p>	<p>Action: Select: </p> <p>Response: Prompt ENTER PARAMETER NAME</p> <p>Action: Type in new parameter name + </p> <p>Response: Trended parameter is now changed</p>
<p><b>Change the high or low limit</b></p>	<p>Action: Select:  OR </p> <p>Response: Prompt ENTER NEW HIGH or LOW LIMIT</p> <p>Action: Type in new high or low limit + </p> <p>Response: High or low limit is now changed</p>

## TREND FUNCTIONS, continued

### Optional Enhanced Trend Pen Recording (continued)

<p><b>Change sampling rate</b></p>	<p>Action: Select: <input type="text" value="SAMPLING RATE"/></p> <p>Response: The following targets appear</p> <p>Action: Select: <input type="text" value="4 SECONDS"/> OR <input type="text" value="1 SECOND"/> OR <input type="text" value="Return to Normal Heading"/></p> <p>Response: Pen value sampling rate changes</p>
<p><b>Change pen status</b></p>	<p>Action: Select: <input type="text" value="PEN STATUS"/> single pen OR <input type="text" value="Status"/> all pens</p> <p>Response: The following targets appear</p> <p>Action: Select: <input type="text" value="Active"/> <input type="text" value="Suspend"/> <input type="text" value="Calibrate"/> <input type="text" value="Return to Normal Heading"/></p> <p>Response: Display updates with new status</p>
<p><b>Change calibration % value</b></p>	<p>Action: Select: <input type="text" value="CALIBRATION %"/></p> <p>Response: Prompt ENTER CALIBRATION</p> <p>Action: Type in new calibration value (0 - 100) + <input type="text" value="ENTER"/></p> <p>Response: Calibration value changes</p>
<p><b>Change the index</b></p>	<p>Action: Select: <input type="text" value="INDEX"/></p> <p>Response: Prompt ENTER INDEX</p> <p>Action: Type in new index value + <input type="text" value="ENTER"/></p> <p>Response: Index value changes</p>
<p><b>Assign trend pen group</b></p>	<p>Action: Select: <input type="text" value="Group"/></p> <p>Response: Prompt ENTER TREND PEN GROUP NUMBER</p> <p>Action: Type in group number + <input type="text" value="ENTER"/></p> <p>Response: New trend pen group display appears</p>

## TREND FUNCTIONS, continued







### Hourly Averages

At an operating Group Display...

<b>Call up hourly averages</b>	Action: Press:  Response: The upper portion of the group display is replaced with hourly averages of up to 10 hours for each point
--------------------------------	--

# SYSTEM MENU FUNCTIONS

## Organizational Summaries

<b>Call up system menu</b>	Action: Press:  Response: The system menu appears on the screen
<b>Manipulate targets in the organizational summary menu</b>	Action: Select:  Response: Organizational summary display is called up
	Action: Select:  Response: Prompt: ENTER UNIT ID Action: Type in unit ID +  Response: Unit point summary is called up
	OR Action: Select:  Response: Prompt: ENTER HIWAY NUMBER Action: Type in Hiway number Type in Box number +  Response: Hiway Box point summary is called up
	OR Action: Select:  Response: Prompt: ENTER POINT ID Action: Type in tag name Response: Point usage list is called up

# SYSTEM MENU FUNCTIONS, continued

## Organizational Summaries (continued)

Manipulate targets  
in the  
organizational  
summary menu

OR  
Action: Select:  UNIT POINT ATTRIBUTE SUMMARY  
Response: Prompt: ENTER UNIT ID  
Action: Type in unit ID +   
Response: Unit Point Attribute Summary appears  
OR  
Action: Select:  AREA POINT ATTRIBUTE SUMMARY  
+   
Response: Area Point Attribute Summary appears

OR  
Action: Select:  LCN NODE POINT SUMMARY  
Response: Prompt TYPE IN NODE ADDRESS  
Action: Type in node address +   
Action: Select:  OR   
Response: LCN node point summary is called up

OR  
Action: Select:  UCN DEVICE POINT SUMMARY  
Response: Prompt ENTER UCN/DEVICE NUMBER  
Action: Type in UCN number  
Action: Type in UCN device number +   
Action: Select:  OR   
Response: UCN device point summary is called up

OR  
Action: Select:  UCN DEVICE MODULE PT SUMMARY  
Response: ENTER UCN/DEVICE/MODULE NUMBER  
Action: Type in UCN number  
Action: Type in UCN device number  
Action: Type in Module number +   
Action: Select:  OR   
Response: UCN device module point summary is called up

# SYSTEM MENU FUNCTIONS, continued

## Organizational Summaries (continued)

<b>Display or print menu items after each target selection</b>	<p>Action: Select: <input type="text" value="DISPLAY"/></p> <p>Response: Any of the targets selected will be displayed</p> <p>Action: Select: <input type="text" value="PRINT"/> Print target is optional</p> <p>Action: Type in printer number + <input type="text" value="ENTER"/></p>						
<b>Call up additional menu items</b>	<p>Action: When selected, the following target displays will appear</p> <table border="0"><tr><td><input type="checkbox"/> AREA TITLES</td><td><input type="checkbox"/> UNIT TREND TITLES</td></tr><tr><td><input type="checkbox"/> UNIT TITLES</td><td><input type="checkbox"/> SCHEMATIC/FFL TITLES</td></tr><tr><td><input type="checkbox"/> GROUP TITLES</td><td></td></tr></table>	<input type="checkbox"/> AREA TITLES	<input type="checkbox"/> UNIT TREND TITLES	<input type="checkbox"/> UNIT TITLES	<input type="checkbox"/> SCHEMATIC/FFL TITLES	<input type="checkbox"/> GROUP TITLES	
<input type="checkbox"/> AREA TITLES	<input type="checkbox"/> UNIT TREND TITLES						
<input type="checkbox"/> UNIT TITLES	<input type="checkbox"/> SCHEMATIC/FFL TITLES						
<input type="checkbox"/> GROUP TITLES							

# SYSTEM MENU FUNCTIONS, continued

## Reports, Logs, Journals or Printed Trends

**Change reports, logs, journals, and printed trends**

Action: Select: 

Response: The following targets appear

Action: Select:  to select a Report, Log, Journal, or Printed Trend

 to print the selected item

 to cancel the print operation

 to suspend periodic printing of the selected item

 to activate periodic printing of the selected item

 to display the selected item on the screen

 to select a new start time

 to select a new start date

 type in the printer number

+  to change the printer assigned to the item

Response: Depending on target selection, changes will be made

## SYSTEM MENU FUNCTIONS, continued

### Reports, Logs, Journals or Printed Trends (continued)

Call up additional menu items

ROLL  
LEFT

OR

ROLL  
RIGHT

to view all 132 columns of the display

### Real-Time Journal Assignments

Call up additional menu items

Action: Select:



REAL TIME JOURNAL ASSIGNMENTS

Response: The following targets appear

Action: Select:

JOURNAL

to select the Real-Time

TYPE

Journal type

SUSPEND

to suspend printing of the selected journal

ACTIVATE

to activate printing of the selected journal

CHANGE  
PRINTER

type in the printer number

+

ENTER

to change the printer assigned to the item

Response: Depending on target selection, changes will be made

# SYSTEM MENU FUNCTIONS, continued

## Event History Menu

Action: Select:  **EVENT HISTORY MENU**

Response: The following targets appear

Action: Select:

<b>PROCESS ALARMS</b>	<b>OPERATOR MESSAGES</b>	<b>SYSTEM STATUS</b>	<b>SOE EVENTS</b>
<b>PROCESS CHANGES</b>	<b>SYSTEM MAINTENANCE</b>	<b>SYSTEM ERRORS</b>	<b>STATUS NOTIFICATIONS</b>

Response: The following targets appear:

for PROCESS ALARMS,  
PROCESS CHANGES, and  
OPERATOR MESSAGES:

<b>UNIT</b>	<b>PRIMMOD</b>	<b>POINT</b>
-------------	----------------	--------------

for SYSTEM MAINTENANCE,  
SYSTEM ERRORS, and  
STATUS NOTIFICATIONS:

<b>NODE</b>	<b>ALL</b>
-------------	------------

for SYSTEM STATUS:

<b>NTWK BOX</b>	<b>NTWK</b>	<b>ALL BOXES</b>
<b>NODE</b>	<b>ALL</b>	

Action: Select target.

Response: UNIT, NODE, PRIMMOD, or POINT targets appear.

Action: Select UNIT, NODE, PRIMMOD, or POINT target.

Response: Cursor box appears below target.

Action: Type in Unit ID, Node Number, or Point ID.

Response: START/STOP, TIME/DATE, PRINT and DISPLAY targets appear.

SELECT the START/STOP TIME/DATE targets and for each, enter the values you want.

## SYSTEM MENU FUNCTIONS, continued

### Event History Menu (continued)

<b>Display or print menu items after each target selection</b>	<p>Action: Select: <input type="button" value="DISPLAY"/></p> <p>Response: The Journal display appears</p> <p>Action: Select: <input type="button" value="PRINT"/> Print journal</p> <p>Action: Type in printer number + <input type="button" value="ENTER"/></p>
--	---

### Process Variable Retrieval

<b>Call up, print, or display the process variable retrieval targets</b>	<p>Action: Select: <input type="button" value="PROCESS VARIABLE RETRIEVAL"/></p> <p>Response: The following targets appear</p> <p>Action: Select: <input type="button" value="VALUE TYPE"/> to select type of historical values to retrieve</p> <p><input type="button" value="POINT or GROUP"/> + <input type="button" value="a #"/> type in a group number, or tag name(s) for up to eight points</p> <p>+ <input type="button" value="ENTER"/></p> <p>Response: The selected type of historical values are retrieved</p> <p>Action: Select: SELECT the START/STOP TIME/DATE targets and for each, enter the values you want.</p> <p>Action: Select: <input type="button" value="DISPLAY"/></p> <p>Response: The variables are displayed on the screen</p> <p>Action: Select: <input type="button" value="PRINT"/> Print variables</p> <p>Action: Type in printer number + <input type="button" value="ENTER"/></p>
--	---

# SYSTEM MENU FUNCTIONS, continued

## Group Display Edit Function

The operator is allotted these 10 groups 391 through 400. These groups allow the operator to organize existing points in any order, but are not permanent, and can be changed at any time.

<p><b>Change Group displays</b></p> 	<p>Action: Select: <input type="checkbox"/> <b>GROUP EDIT DISPLAY</b></p> <p>Response: The following targets appear (391-400)</p> <p>Action: Select: <input type="text" value="GROUP NUMBER"/> OR <input type="text" value="OTHER"/></p> <p>Response: If you selected OTHER, a text box appears for you to enter a group number</p> <p>Action: Type in a group number 1 to 390 + <input type="button" value="ENTER"/></p>
<p><b>Change Group titles</b></p>	<p>Action: Select: <input type="button" value="CHANGE"/></p> <p>Response: Targets appear allowing you to enter a new group title</p> <p>Action: Type in new group title + <input type="button" value="ENTER"/></p> <p>Response: A new group title is now entered</p>
<p><b>Change Tag names</b></p>	<p>Action: Select: <input type="button" value="CHANGE"/></p> <p>Response: Targets appear allowing you to enter a new tag name in positions (1-8)</p> <p>Action: Type in new tag name + <input type="button" value="ENTER"/></p> <p>Response: Tag name changes</p>
<p><b>Delete a point on the display</b></p>	<p>Action: Select: <input type="button" value="DELETE"/></p> <p>Response: Targets appear allowing you to delete a new tag name in positions (1-8)</p> <p>Action: Select tag name + <input type="button" value="ENTER"/></p> <p>Response: Point is now deleted</p>



# SYSTEM MENU FUNCTIONS, continued

## Overview Edit Display Function



### Change Group element

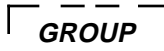

Action: Select: 



Response: The following target appears

Action: Select:   

Response: The following targets appear

 +  to delete (hide) the group from the display

 +  to suppress alarm displays for the selected group

 +  to enable all normal displays for the selected groups

Response: Group element changes

## Removable Media Initialization

### Initialize removable media



Action: Select: 

Response: The following targets appear



Action: Select:

 OR  Select appropriate drives + 

Response: The following target appears

Action: Select:  Type in 4 character volume name + 

Response: The following target appears

Action: Select:  Type in 20 character descriptor + 

Response: Floppy or Cartridge becomes initialized

# SYSTEM MENU FUNCTIONS, continued

## Custom Name Save

Save custom names



Action: Select: ■ CUSTOM NAME SAVE

Response: The following targets appear

Action: Select:

DEFAULT SOURCE OR ALTERNATE SOURCE Select appropriate + drives

Response: The following target appears

Action: Select: CHANGE DESCRIPTOR Type in 20 character descriptor + ENTER

Response: The following target appears

Action: Select: EXECUTE COMMAND

Response: Custom parameter names to the selected volume begins saving

## Clear the Screen

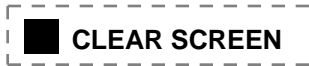

## HTD Panel Operations

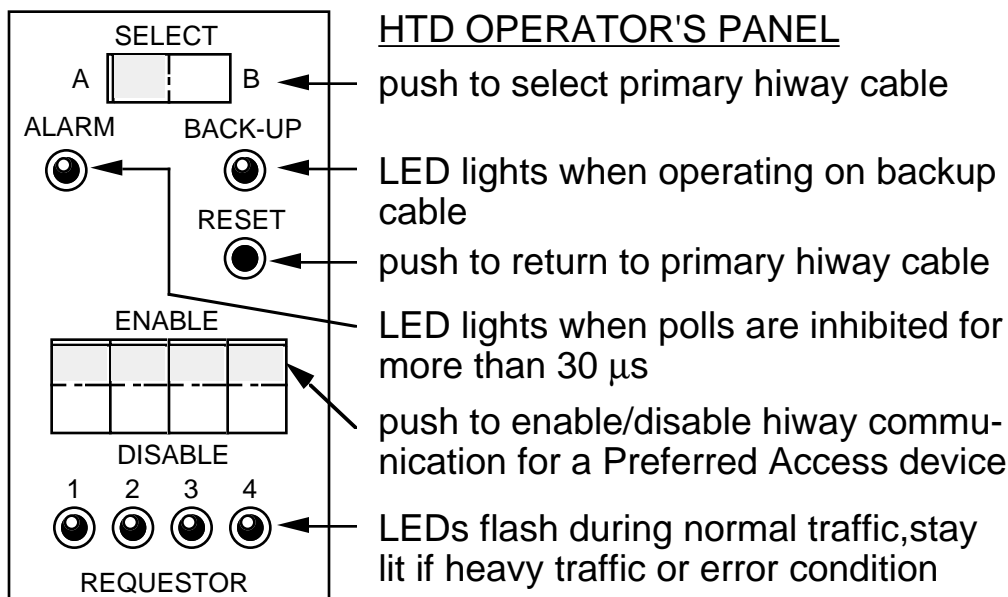

# ALARM AND STATUS INDICATORS

## Group and Detail Display Indicators

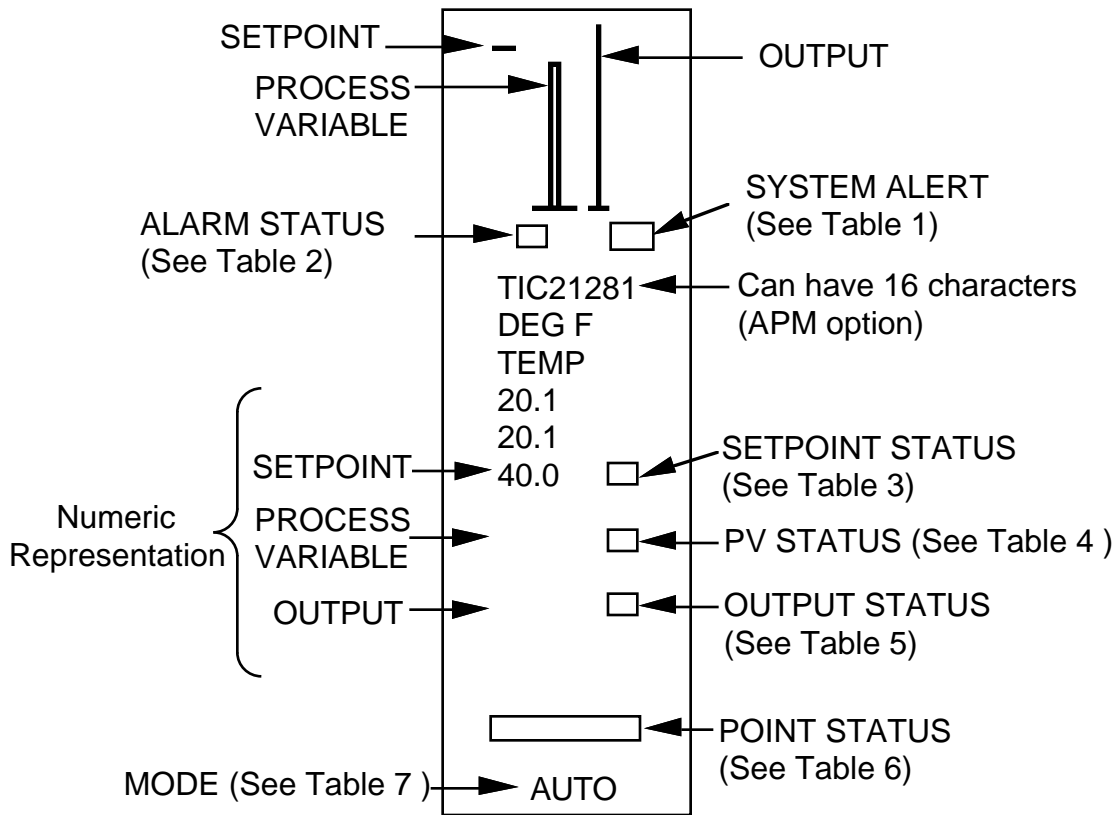

- SP and PV are always shown in Engineering Units
- ????? = Values not accessible
- ----- = Invalid values
- RESET = Hiway box in reset condition

### ANALOG-POINT INFORMATION ON GROUP/DETAIL DISPLAY

# ALARM AND STATUS INDICATORS, continued

## Group and Detail Display Indicators (continued)

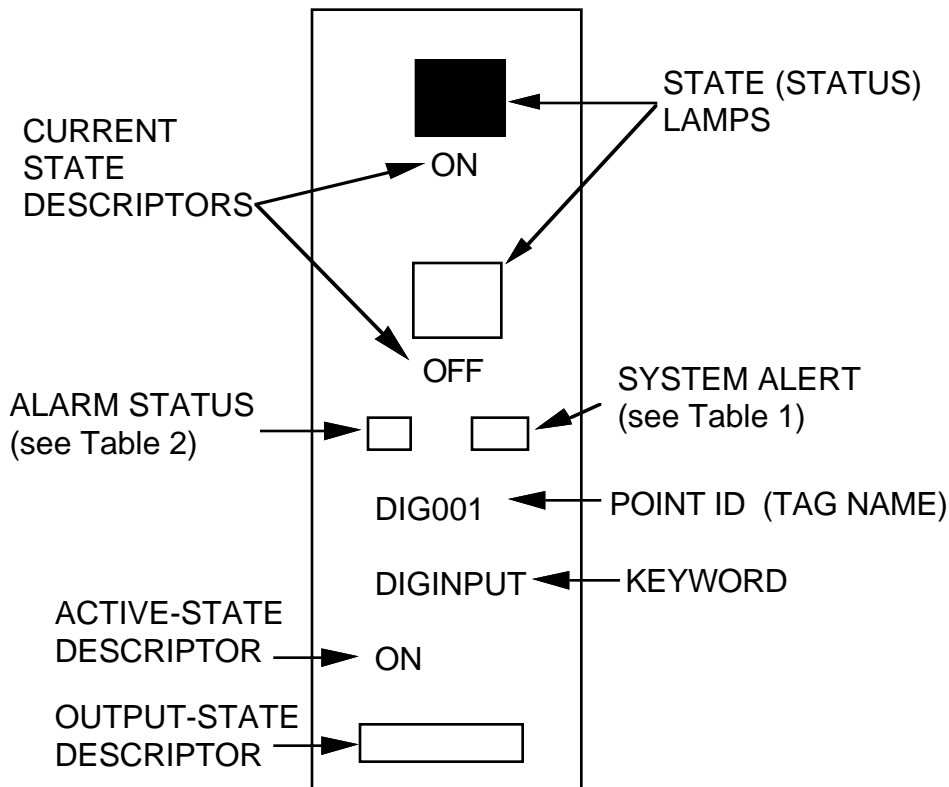

**STATUS CODES/NOTES**

- ????? = Values not accessible
- ----- = invalid state/input
- RESET = Hiway box in reset state
- CL SWITCH points show S1 or S2 Request Status for SP, and S1 or S2 Current Status for OP

**NOTES**

- Points with two inputs/two outputs show only inputs as state lamps
- Switch-type points can show up to four state lamps
- For dual-digital inputs: INBETWEEN = both state lamps filled FAULTY = both state lamps empty

**DIGITAL/FLAG/CL SWITCH-POINT INFORMATION ON GROUP/DETAIL DISPLAY**

# ALARM AND STATUS INDICATORS, continued

## Group and Detail Display Indicators (continued)

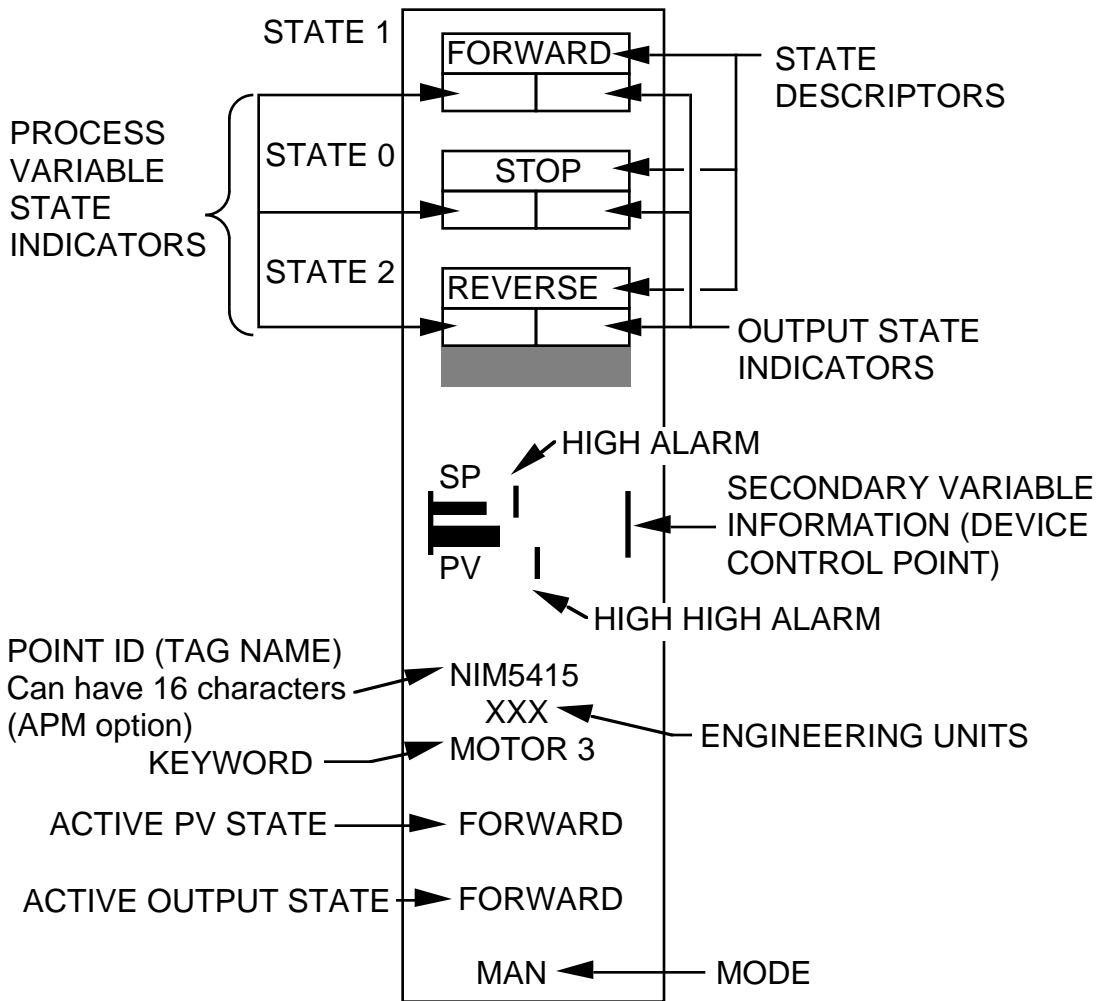

**DIGITAL COMPOSITE AND DEVICE CONTROL POINT INFORMATION ON GROUP/DETAIL DISPLAY**

## ALARM AND STATUS INDICATORS, continued

### Group and Detail Display Indicators (continued)

**TABLE 1 — SYSTEM ALERT INDICATORS**

INDICATOR	MEANING
S	Point's box database saved (UAC Reserve Controller)
I	Point is in IDLE state; MC, PM, APM, LM
F	Point failed; PIU, MC, PM, APM, LM
U	DHP not scanning point; possible bad PC-configuration address
R	Point is in RESET state; Data Hiway points
<b>NOTE: All indicators displayed in yellow</b>	

# ALARM AND STATUS INDICATORS, continued

## Group and Detail Display Indicators (continued)

**TABLE 2 — ALARM STATUS INDICATORS**

INDICATOR	MEANING	SOURCE DEVICES
[BLANK]	Point not in alarm or status not accessible	All devices
* (yellow)	Overview Tracer: indicates when point's PV deviation from the setpoint is greater than the overview value	AM, PM, APM
A	Flag Alarm State	HG, AM
ADV	Advisory Deviation	AM, PM, APM
BC	Bad Control Flag Alarm	AM, PM, APM
BGI	Bad General Input	AM
BP	Bad Process Variable	AM, PM, APM
BSV	Bad Secondary Variable	AM, PM, APM
C1, C2 C3, C4	Custom Alarms	
CLE	CL Error	AM, PM, APM
CLF	CL Fail	AM, PM, APM
CMF	Command Fail	PM, APM
CNF	Configuration Alarm	AM, PM, APM
COS	Digital Change of State	PM, APM
DFN	Digital Off Normal	AM, PM, APM
DIS	Disabled alarm enable status (R510 and later)	AM, NIM, HG
NOTE: Indicator color (red or yellow) corresponds to alarm's priority. For example: Red = Emergency, Yellow = High or Low		

(Continued next page)

# ALARM AND STATUS INDICATORS, continued

## Group and Detail Display Indicators (continued)

**TABLE 2 — ALARM STATUS INDICATORS (continued)**

INDICATOR	MEANING	SOURCE DEVICES
0DV	Preset Alarm (Timer/Counter Points)	AM, EC
1DV	Pre-Preset Alarm (Timer/Counter Points)	AM, EC
2DV	Pre-Pre-Preset (Timer/Counter Points)	AM, EC
FB	Digital Feedback (Command Disagree)	PM, APM
HD	Deviation High	HG, AM, PM, APM
2HD	Deviation High High	HG
3HD	Deviation High High High	HG
HP	PV High	HG, AM, PM, APM
2HP	PV High High	AM, EC, PM, APM
3HP	PV High High High	EC
HS	Secondary Variable High	APM
2HS	Secondary Variable High High	APM
INH	Alarms are inhibited (overwrites display of alarm status indicator)	All devices
INV	Invalid Alarm State	HG, AM, PM, APM
LD	Deviation Low	HG, AM, PM, APM
2LD	Deviation Low Low	HG
3LD	Deviation Low Low Low	HG
NOTE: Indicator color (red or yellow) corresponds to alarm's priority. For example: Red = Emergency, Yellow = High or Low		

(Continued next page)

## ALARM AND STATUS INDICATORS, continued

### Group and Detail Display Indicators (continued)

**TABLE 2 — ALARM STATUS INDICATORS (continued)**

INDICATOR	MEANING	SOURCE DEVICES
LP	PV Low	HG, AM, PM, APM
2LP	PV Low Low	AM, EC, PM, APM
3LP	PV Low Low Low	EC
OFN	Off Normal	PM, APM
ORC	Output Rate of Change	HG, PM, APM
OTC	Open Thermocouple	PIUs
OV0	Interlock Tripped, State 0	APM
OV1	Interlock Tripped, State 1	APM
OV2	Interlock Tripped, State 2	APM
PSC	PV Significant Change	AM, PM, APM
RC+	Positive Rate of Change	AM, PM, APM
RC-	Negative Rate of Change	AM, PM, APM
ROC	Rate of Change	EC
S4	S4 Logic Alarm	EC, AM, PM, APM
SHD	Computer Shed	HG, AM, PM, APM
SI0	Safety Interlock Tripped, State 0	APM
SO	Schedule Overrun	AM
SW1 - SW3	Switch Alarms	HG, AM, PM, APM
TMO	Timeout (Timer/Counter)	HG, AM, PM, APM
UNC	Uncommanded Change	PM, APM
UNR	Unreasonable PV	PM, APM

NOTE: Indicator color (red or yellow) corresponds to alarm's priority.  
For example: Red = Emergency, Yellow = High or Low

## ALARM AND STATUS INDICATORS, continued

### Group and Detail Display Indicators (continued)

**TABLE 3 — SETPOINT STATUS INDICATORS**

INDICATOR	MEANING
P	Target value processing is Preset: AM only
R	Target value processing is Running: AM only
*	When point is in manual mode, setpoint is only used as target value. No control action occurs.
H	Setpoint High Limit
L	Setpoint Low Limit
^	Setpoint cannot be increased due to limiting on output.
V	Setpoint cannot be decreased due to limiting on output.
B	Bad Setpoint

## ALARM AND STATUS INDICATORS, continued

### Group and Detail Display Indicators (continued)

**TABLE 4 — PV STATUS INDICATORS**

<b>INDICATOR</b>	<b>MEANING</b>
Red B	Bad PV
Red H	Bad PV and PV High Extended Range Violation
Red L	Bad PV and PV Low Extended Range Violation
Red M	Bad PV and PVSOURCE is MANual
Red S	Bad PV and PVSOURCE is Substituted
Yellow U	PV is Uncertain
Yellow H	PV is Uncertain and PV Clamped to High Extended Range
Yellow L	PV is Uncertain and PV Clamped to Low Extended Range
Yellow M	PV is Uncertain and PVSOURCE is MANual
Yellow S	PV is Uncertain and PVSOURCE is Substituted
Blank	Normal

## ALARM AND STATUS INDICATORS, continued

### Group and Detail Display Indicators (continued)

**TABLE 5 — OUTPUT STATUS INDICATORS**

INDICATOR	MEANING
*	Indicates that integral ramping of the controller has been stopped.
H	OP High Limit
L	OP Low Limit
^	Secondary of this point is at setpoint or output High limit. Output is only allowed to decrease.
v	Secondary of this point is at setpoint or output Low. Output is only allowed to increase.

## ALARM AND STATUS INDICATORS, continued

### Group and Detail Display Indicators (continued)

**TABLE 6 — POINT STATUS INDICATORS**

INDICATOR	MEANING
BAD TYPE	Point type cannot be configured in Group
MISMATCH	Database does not match Area database
INACTIVE	Point is Inactive
OUT SERV	Point is Out Of Service
RED TAG	Point Red Tagged
INIT	Point being Initialized, cascade broken, or output destination unavailable.
TEST	Point in test
EXP	Timer Expired
CNFG ERR	Point not present when database built
SEL	Point Selected by Override Selector
NOT SEL	Point Not Selected by Override Selector
CFM	Confirmable Message on point (ACIDP point type)
xxxx	Program Abort Code for ACIDP in CM-60; xxxx (for example 2B17) indicates the specific reason for the point-processing abort. Refer to the CM60 Users Manual, heading 3.6.3 for further information.

# ALARM AND STATUS INDICATORS, continued

## Group and Detail Display Indicators (continued)

**TABLE 7 — MODE INDICATORS**

INDICATOR	MEANING
LOC MAN	Local (Loop) Manual; the Output is being set locally at the Hiway box
MAN	MANUAL: OP controlled by Operator
AUTO	AUTOMATIC: OP calculated by algorithm based on operator-controlled setpoint
CAS	CASCADE: SP or OP is from AM or CM or from point in same Hiway controller file
BCAS	Backup CASCADE: SP or OP of Hiway controller point that was being set by an LCN Module (AM, CM), is now being set by a point in the same Hiway controller file; in other words; the LCN module has shed control. BCAS applies to HG points only.
P MAN	Program MANUAL, OP controlled by CL/FORTRAN/Pascal program in AM or CM
P AUTO	Program AUTO: SP controlled by CL/FORTRAN/Pascal program in AM or CM
<p>NOTES<sup>1</sup>:</p> <p>in the same controller applies to BC and MC points; EC points can cascade to points in other boxes.</p> <p>C after the Mode means a CASCADE-request has been made; does not apply to AM.</p> <p>Mode in reverse-video (for example, <b>MAN</b> ) means that the point IS NOT in its NORMALLY configured Mode.</p>	

(Continued next Page)

## ALARM AND STATUS INDICATORS, continued

### Group and Detail Display Indicators (continued)

**TABLE 7 — MODE INDICATORS (continued)**

INDICATOR	MEANING
P CAS	Program CASCADE: SP or OP set by a CL program
P BCAS	Program BCASCADE: for secondary points in a cascade whose primary is in a different LCN Module; when the Module containing the Primary fails, the secondary point enters this Mode if CASCADE is the configured shed mode.
RUNNING STOPPED TIMEOUT COUNTOUT	Current operating state of PM/AM- or DHP-based Timers, Counters, or Analog Accumulation points.
RUN RUN/REPT HOLD HOME JOG	Current operating state of a point with a CL Sequence
??????	Mode is inaccessible
!!!	Mode is indeterminate: PIU only
-----	Mode is invalid
MOD	Multifunction controllers analog output is being controlled by one of the MCs Control Slots
<p>NOTES:</p> <p>C after the Mode means a CAScade-request has been made; does not apply to AM.</p> <p>Mode in reverse-video (for example, <b>MAN</b> ) means that the point IS NOT in its NORMALLY configured Mode.</p>	

## ALARM AND STATUS INDICATORS, continued

### System Status Display Indicators

**TABLE 8 — NODE STATUS STATES**

<b>STATE</b>	<b>MEANING</b>
OK	All nodes are either running, alive, qualified, or under test
FAIL	One or more nodes have failed
MAINT	One or more nodes have Maintenance Recommendations
ERRORS	One or more nodes have an Auxiliary Node Status

**TABLE 9 — PROCESS NETWORK STATUS STATES**

<b>STATE</b>	<b>MEANING</b>
OK	Boxes, devices, and cables are OK
FAIL	One or more boxes or Devices have failed
INIT	Hiway or UCN is starting up
????	Status is unavailable from Hiway or UCN
SWITCH	Cable switch in progress
IDLE	One or more MCs or LMs are in IDLE (ready for program load) or one or more PMs/APMs are in IDLE

## ALARM AND STATUS INDICATORS, continued

### System Status Display Indicators (continued)

**TABLE 10 — LCN CABLE STATUS INDICATOR**

<b>INDICATOR</b>	<b>MEANING</b>
REVERSE- VIDEO	Active cable
GREEN	Normal condition (auto-cable swaps every minute)
YELLOW	Possible bad cable (auto-cable swaps every 10 min.)
RED	Total cable failure

## ALARM AND STATUS INDICATORS, continued

### Universal Station/Gateway/Module Display Indicators

**TABLE 11 — STATION GATEWAY MODULE STATUS INDICATOR**

INDICATOR	MEANING
OK	Node is qualified, loaded, and running "on-process."
BACKUP	Node is qualified and is the backup for the other node of this node pair.
OFF	Node is not on the LCN, or power is off.
PWR_ON	Power is on but the node is not yet qualified or loaded.
QUALIFY	Quality Logic Tests or self-tests are running.
READY	Node is qualified but not loaded.
FAIL	Power is applied but the node has failed.
TEST	Node has been placed in Test state to run its Maintenance Personality.
ENGR	Universal Station is loaded with the Engineer's Personality.

# ALARM AND STATUS INDICATORS

## Hiway Status Display Indicators

The following table lists the more common *informative* display indicators. *Failure* indicators (not listed in this table) are preceded by a double-dash; their detailed meaning can be determined by looking at the specific Box Status Display, or by referring to the *Process Operations Manual* or the *Basic System Service* binder TDC-355.

**TABLE 12 — HIWAY BOX STATUS INDICATORS**

MESSAGE	MEANING
OK	The box is functioning normally.
OK CP INHBT	The box is functioning normally, but automatic checkpointing has been inhibited for this box or hiway; manual checkpointing is still permitted.
*	Save or Load of checkpoint data is in progress.
ALM FAIL	The controller is no longer performing the Alarm Reporting function (EC & MC only).
BAD STATE	The box was not in a proper state for saving/loading data from/to the box.
FILE ERROR	An error occurred during loading of box data. This can be caused if the data is being loaded from a write-protected cartridge or floppy disk.
LOADED	Trend Program was fully transmitted over the hiway and the Trend Program is running.
NO MEMORY	The controller does not contain a memory card.
NO RESPONSE	The controller is not responding to continued hiway requests.
NOT ATTEMPT	The requested operation was not attempted because an error condition was detected.

(Continued next page)

## ALARM AND STATUS INDICATORS, continued

### Hiway and UCN Status Display Indicators

**TABLE 12 — HIWAY BOX STATUS INDICATORS (cont.)**

MESSAGE	MEANING
NOT LOADED	The controller did not allow startup of the Trend Program, or the Trend Program failed on startup.
NOW RUNNING	The trend program is currently running
RESTORED	The data was successfully restored to the box from a checkpoint file.
SAVED	The box data was successfully saved in a checkpoint file.
TND RUNNING	The trend program is currently running.
TRND LOADED	Trend Program was fully transmitted over the hiway and the Trend Program is running.
WRONG TYPE	The box type configured in the Universal Station database disagreed with the type of corresponding box on the hiway.

**TABLE 13 — UCN DEVICE STATUS INDICATORS**

STATE	MEANING
OK	No failures, running normally.
BACKUP	Device is operating in backup capacity with no failures and running normally.
IOIDL	One or more I/O Processors are in IDLE. No failures.
IDLE	PMM/APMM or LM is in IDLE. Some I/O Processors may be in IDLE, but PMMIDL overrides IOIDL. No failures.
PARTFAIL	Partial failures. The PMM/APMM or LM has one or more soft failures.

(Continued next page)

## ALARM AND STATUS INDICATORS, continued

### Hiway and UCN Status Display Indicators (continued)

**TABLE 13 — UCN DEVICE STATUS INDICATORS (cont.)**

STATE	MEANING
PF_IOIDL	There are one or more partial failures and one or more I/O Processors are in IDLE.
PF_IDLE	There are one or more partial failures and the PMM/APMM or LM is in IDLE.
OFFNET	PMM/APMM or LM is not responding on the UCN because 1) it does not exist, 2) it is powered off, or 3) it has a hardware failure that prohibits it from responding.
POWERON	PMM/APMM or LM is responding on the UCN, but has not yet run its self-tests. This is a transitory state that occurs when the PMM/APMM is powered on before the self-tests finish.
ALIVE	PMM/APMM or LM is responding on the UCN, but is neither loaded nor functioning.
LOADING	PMM/APMM is being loaded.
NOTCONFIG	There is no node configured at this UCN node address.
CONFGMIS	The node type that exists at this UCN address does not match the type that is configured for this address.
NOSYNCH	Secondary PMM/APMM is running, but has failed to synch its database with the primary.
FAIL	The PMM/APMM is hard failed, and therefore access to I/O Processor status and data is unavailable. PMM/APMM control functions have ceased; effectively a total PM or APM failure.
COMMFALL	NIM cannot communicate with any other node.
UNKNOWN	When the primary NIM is in the COMMFALL state, all other nodes on that UCN are in the UNKNOWN state until the primary NIM reestablishes communication.

## ALARM AND STATUS INDICATORS, continued

### UCN Status Display Indicators

**TABLE 14 — PMM AND APMM STATUS INDICATORS**

STATE	MEANING
OK	No failures, running normally.
BACKUP	Device is operating in backup capacity with no failures and running normally.
BKUP_SF	Backup APM/PM has detected a soft failure.
APM IDLE	APM is in idle state and no communication to serial interface input/output processor.
IDLE	Node is idle, but contains no failures.
SOFTFAIL	Node contains one or more soft failures.
IDLESF	Node is idle and contains one or more soft failures.
OFFNET	PMM/APMM is not responding on the UCN because 1) it does not exist, 2) it is powered off, or 3) it has a hardware failure that prohibits it from responding.
POWERON	PMM/APMM is responding on the UCN, but has not yet run its self-tests. This is a transitory state that occurs when the PMM is powered on before the self-tests finish.
ALIVE	PMM/APMM is responding on the UCN, but is neither loaded nor functioning.
ALIVESF	PMM/APMM is ALIVE and contains one or more soft failures.
LOADING	PMM/APMM is being loaded.
NOTCONFIG	There is no node configured at this UCN node address.
CONFGMIS	The node type that exists at this UCN address does not match the type that is configured for this address.
NOSYNCH	Secondary PMM/APMM is running, but has failed to synch its database with the primary PMM/APMM.
FAIL	Node has hard-failed and is totally nonfunctional.
UNKNOWN	Transitional status: the APMM is changing from one state to another.

## ALARM AND STATUS INDICATORS, continued

### PM/APM Detail Status Display Indicators

**TABLE 15 — I/O PROCESSOR STATUS INDICATORS**

STATE	MEANING
OK	No failures, running normally.
IDL	IDLE. Node is idle, but contains no failures.
SF	SOFTFAIL. Node contains one or more soft failures.
IDLESF	Node is idle and contains one or more soft failures.
POWERON	Processor is on the I/O Link, but self-tests are not completed. This is a transitory state that occurs when power is turned on.
NR	NORESP. Processor firmware does not respond to the I/O Link communications, but hardware acknowledges messages. Indicates a hard processor failure.
NONEXIST	Processor firmware does not respond on the I/O Link.
COMMERR	Cannot communicate with the processor.
CFG	CONFGMIS. The I/O Processor type that exists in this card slot does not match the type that is configured for this slot.
IOP COMM	Serial Interface input/output processor is not present or APM is in process of loading array point configuration to serial interface input/output processor (transient state).
BKP	Backup (status) of redundant IOP card.
DB_VALID	Database is valid.
DBINVALD	Database is invalid. Database has to be reloaded or restored into IOP.

## ERROR MESSAGES

**TABLE 16 — ERROR MESSAGES**

MESSAGE	MEANING/CORRECTIVE ACTION
ACCESS LEVEL ERROR	The requested action cannot be performed unless the Universal Station keyswitch is switched to a higher level of access ( <b>SUPVR</b> or <b>ENG</b> ).
ILLEGAL BAD VALUE VALUE INVALID	An invalid entry was typed.
DATA ACCESS ERROR	Parameter does not exist for the selected point.
DATA NOT AVAILABLE	Data does not exist for the given point and time (history).
DEVICE RESET	The module or device where the point resides is in the RESET mode; no entry is allowed.
DISPLAY NOT CONFIGURED	The display requested does not exist on the system.
ENTITY NOT FOUND CANNOT FIND POINT	Tag name entered does not exist.
FAIL: USnn	US failed during a load.
INITIALIZATION	Selected parameter cannot be changed with point in current initialization mode.
INVALID ENTRY	An invalid entry was typed.
INVALID MODE PVSOURCE INVALID	Selected parameter cannot be changed with point in current mode.

(Continued next page)

## ERROR MESSAGES, continued

**TABLE 16 — ERROR MESSAGES (continued)**

ATTRIBUTE	MEANING
INIT ERROR	The selected parameter cannot be changed because the point is in initialization mode.
LMT OR RANGE ERR	An attempt was made to change the value of a clamped parameter beyond the range limit.
NO CONFIGURED TREND	No trend data is available for the selected point.
PNT STATUS ERR	The module or device where the point resides has failed; no entry is allowed.
PRINTER NOT CONFIGURED	The print request could not be honored because the requested printer number is not valid.
PRIOR FUNCTION NOT COMPLETED	A previous function or activity must complete before the requested function can be started.
READ ONLY PAR	The selected parameter is for viewing only and cannot be changed by the operator.
RED TAG	All output entries are disallowed; the point is "Red-Tagged."
START TIME IS AFTER STOP START DATE IS AFTER STOP DATE OR TIME EXPECTED	The requested time base is incorrect.
SYS: UNABLE TO OPEN NCF FILE	NCF file is not on the network.
UNIT NOT CONFIGURED	Entered Unit ID does not exist or is not assigned to this station's Area.

## POINT ATTRIBUTE DESCRIPTIONS

**TABLE 17 — POINT ATTRIBUTE DESCRIPTIONS**

ATTRIBUTE	MEANING
ALARM INHIBIT	Alarms are set to the INHIBIT state (no annunciation, no history collection, no journaling, and not shown on alarm displays).
ALARM DISABLE	Alarms are set to the DISABLE state (no annunciation and are not shown on alarm displays).
INACTIVE	Point execution status is set to INACTIVE.
MANUAL PV	PV source is set to MANUAL.
SUBSTITUTED PV	PV source is set to SUBSTITUTED (from external computation).
UNCERTAIN PV	Universal Station is receiving a questionable PV value.
BAD PV	Universal Station is receiving an invalid PV value.
TRACK PV	Currently operating in PV Tracking mode.
MANUAL MODE	Control mode is currently MANUAL.
BCAS MODE	Control mode is currently Backup Cascade (the assigned local data point has taken over as primary).
BCAS MODE	Control mode is currently Backup Cascade (the assigned local data point has taken over as primary).
CASCADE REQUEST MODE	A request for the point to enter cascade mode had been made, but a failure condition prevents implementation of the request.
PROGRAM MODE	Currently operating in Program mode; the setpoint is provided by software.

(Continued next page)

## POINT ATTRIBUTE DESCRIPTIONS, continued

**TABLE 17 — POINT ATTRIBUTE DESCRIPTIONS (cont.)**

MESSAGE	MEANING
COMPUTER SHED	The high-level processor has been disengaged from the control loop.
INITIALIZED	Currently undergoing initialization.
BYPASS	Digital composite or device control point with an interlock or permissive that has been bypassed.
RED TAGGED	Tagged with a red marker; output change is disallowed.
OVERRIDE ALARM W/CF	Override alarm that is awaiting confirmation.
The following attributes apply to Process Module Points:	
LOADED	CL program is Loaded.
NOT LOADED	CL program is Not Loaded.
ERROR	Error has occurred during program execution.
FAIL	Failure has occurred during program execution.
HOLD	Operating status is HOLD.
SHUTDOWN	Operating status is SHUTDOWN.
EMERGENCY SHUTDOWN	Operating status is EMERGENCY SHUTDOWN.

## UNIVERSAL STATION<sup>X</sup> WINDOWS

This procedure applies only to a Universal Station with X Windows.

To resize a window, place the cursor at an edge or corner of the window. The cursor will change to a small line and arrow that indicates the border(s) that will move. Press the mouse/trackball button and hold while dragging the border(s) to the desired location. Release the button.

The following illustration shows the cursor targets that can be used to manipulate the windows on the screen of a Universal Station<sup>X</sup>.

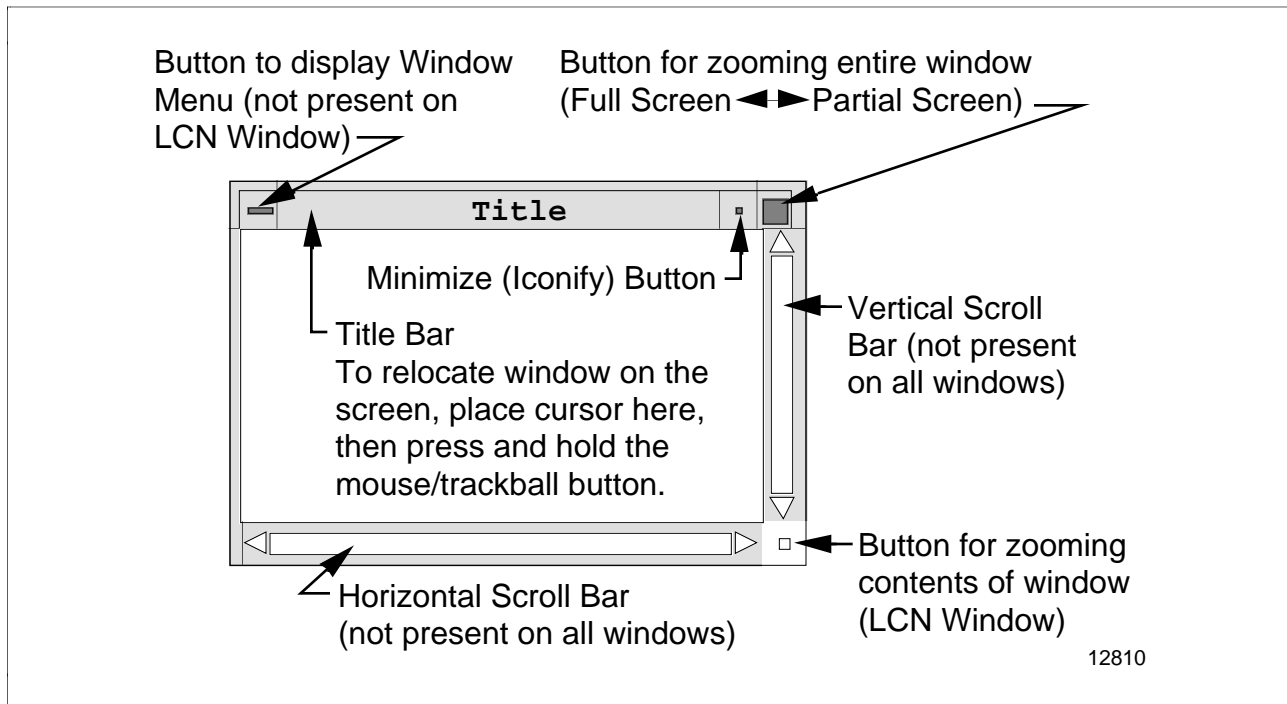

To restore an iconified window:

- Double-Click with the cursor on the icon, or
- Click once with the cursor on the icon, and make the appropriate selection from the resulting menu.





To access items under the workspace (root) menu:

- Open the menu by placing the cursor in a screen area outside all windows, then pressing and holding down the mouse/trackball select button.
- Drag the cursor down the menu list to the desired selection, releasing the button to select that item. If this opens a submenu, click on the desired submenu item.

# RULA DISCONNECT PROCEDURES

Use either of the following procedures to release a station from a RULA connection and regain use of the station for normal operations. Disconnect may be done on either the Host or Remote RULA Station. You cannot use the Quick Disconnect Procedure to disconnect the RULA diagnostic mode. For additional information, see the RULA User Manual.

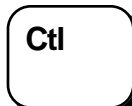
## Quick RULA Disconnect Procedure

<b>Procedure for Quick RULA Disconnect</b>	Action: On a Universal Station Engineering Keyboard,
	hold down  and press  on numeric keypad
	<b>OR</b>
	Action: On a Universal Station X Auxiliary Keyboard,
	hold down  and press  on numeric keypad
	Response: Station is released from the RULA connection and the disconnection is journaled.

## RULA Disconnect Procedure

Place keyswitch in the Engineer position.

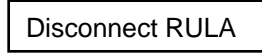
<b>Procedure for RULA Disconnect</b>	Action: From the Console Status Display,
	select 
	Response: RULA Control Display appears.
	Action: Select 
	Response: The station is released from the RULA connection and the disconnection is journaled.

## TDC 3000<sup>X</sup> ACRONYMS

### Networks

LCN	Local Control Network
PIN	Plant Information Network
UCN	Universal Control Network

### UCN Devices

APM	Advanced Process Manager
LM	Logic Manager
PM	Process Manager

### LCN Devices

AM	Application Module
ARM	Archive Replay Module
CG	Computer Gateway
CLM	Communications Link Module
EPLCG	Enhanced Programmable Logic Controller Gateway
HG	Hiway Gateway
HM	History Module
NG	Network Gateway
NIM	Network Interface Module
PCNM	Personal Computer Network Manager
PLCG	Programmable Logic Controller Gateway
PLNM	Plant Network Module
SAM	Scanner Application Module
US	Universal Station
UXS	Universal Station <sup>X</sup>
UWS	Universal Work Station

### Hiway Devices

A-MC	Advanced Multifunction Controller
CB	Basic Controller
CPC	Critical Process Controller
DHP	Data Hiway Port
EC	Extended Controller
GCPI	General Purpose Computer Interface
HG	Hiway Gateway
HIM	Hiway Interface Module
HLPIU	High Level Process Interface Unit
HTD	Hiway Traffic Director
LEPIU	Low Energy Process Interface Unit
LLPIU	Low Level Process Interface Unit
MC	Multifunction Controller
PCSI	Personal Computer Serial Interface

## **Notes**

---

While this information is presented in good faith and believed to be accurate, Honeywell disclaims the implied warranties of merchantability and fitness for a particular purpose and makes no express warranties except as may be stated in its written agreement with and for its customer.

In no event is Honeywell liable to anyone for any indirect, special or consequential damages. The information and specifications in this document are subject to change without notice.