

MOD 30ML™ Multiloop Controller

Installation

Product Description, Installation and Wiring for
1800R Models A and B and Associated Hardware



ABB INSTRUMENTATION

The Company

ABB Instrumentation is an established world force in the design and manufacture of instrumentation for industrial process control, flow measurement, gas and liquid analysis and environmental applications.

As a part of ABB, a world leader in process automation technology, we offer customers application expertise, service and support worldwide.

We are committed to teamwork, high quality manufacturing, advanced technology and unrivaled service and support.

The quality, accuracy and performance of the Company's products result from over 100 years experience, combined with a continuous program of innovative design and development to incorporate the latest technology.

The NAMAS Calibration Laboratory No. 0255(B) is just one of the ten flow calibration plants operated by the Company, and is indicative of ABB Instrumentation's dedication to quality and accuracy.

BS EN ISO 9001



St Neots -
Certificate No. Q5907
Stonehouse -
Certificate No. FM 21106

ISO 9001



Rochester, USA -
Certificate No. AQ-8618



EN 29001 (ISO 9001)





Lenno, Italy -
Certificate No. 90/90A





Stonehouse -
Certificate No. 0255

Use of Instructions

 **Warning.** An instruction that draws attention to the risk of injury or death.

 **Note.** Clarification of an instruction or additional information.

 **Caution.** An instruction that draws attention to the risk of the product, process or surroundings.

 **Information.** Further reference for more detailed information or technical details.

Although Warning hazards are related to personal injury, and **Caution** hazards are associated with equipment or property damage, it must be understood that operation of damaged equipment could, under certain operational conditions, result in degraded process system performance leading to personal injury or death. Therefore, comply fully with all **Warning** and **Caution** notices.

Information in this manual is intended only to assist our customers in the efficient operation of our equipment. Use of this manual for any other purpose is specifically prohibited and its contents are not to be reproduced in full or part without prior approval of ABB Instrumentation.

Licensing, Trademarks and Copyrights

MOD 30 and MOD 30ML are trademarks of Asea Brown Boveri, Inc.
MODBUS is a trademark of Modicon Inc.

Health and Safety

To ensure that our products are safe and without risk to health, the following points must be noted:

1. The relevant sections of these instructions must be read carefully before proceeding.
2. Warning Labels on containers and packages must be observed.
3. Installation, operation, maintenance and servicing must only be carried out by suitably trained personnel and in accordance with the information given or injury or death could result.
4. Normal safety procedures must be taken to avoid the possibility of an accident occurring when operating in conditions of high pressure and/or temperature.
5. Chemicals must be stored away from heat, protected from temperature extremes and powders kept dry. Normal safe handling procedures must be used.
6. When disposing of chemicals, ensure that no two chemicals are mixed.

Safety advice concerning the use of the equipment described in this manual may be obtained from the Company address on the back cover, together with servicing and spares information.

CONTENTS

	Page
SECTION 1 - PRODUCT DESCRIPTION	
1.1 OVERVIEW	1
1.1.1 Features	3
1.1.2 Related Documents.....	4
1.2 EXPLANATION OF CATALOG NUMBERS	4
1.2.1 General.....	4
1.2.2 Electrical Codes	4
1.3 BASIC HARDWARE	5
1.3.1 1800R MOD 30ML MULTILoop CONTROLLER.....	5
1.3.2 1800P MOD 30ML Identity Module	6
1.3.3 2010P MODCELL Memory Module.....	6
1.4 I/O MODULES	7
1.4.1 2001A Voltage Input Module	7
1.4.2 2002A Current Input Module	7
1.4.3 2012A Current Input Module (with 2-wire transmitter power).....	8
1.4.4 2013A Thermocouple Input Module (with upscale burnout detector).....	8
1.4.5 2003A Current Output Module	9
1.4.6 2004A Solid-State Relay Input Module	10
1.4.7 2005A Solid-State Relay Output Module.....	10
1.4.8 2006A Nonisolated Digital Input Module	11
1.4.9 2007A Nonisolated Digital Output Module	11
1.4.10 2011A Mechanical Relay Output Module	12
1.4.11 2009A RTD Input Module.....	12
1.4.12 2020N Remote I/O Interface Module	13
1.5 COMMUNICATIONS MODULES	13
1.5.1 2030N ICN Communication Module.....	13
1.5.2 2032N RS-485 Communication Module for Modbus (2-Wire).....	14
1.5.3 2033N RS-232 Communication Module for Modbus.....	14
1.5.4 2034N RS-485 Communication Module for Modbus (4-Wire).....	15
1.5.5 2030F ICN Terminator	15
SECTION 2 - MECHANICAL INSTALLATION	
2.1 GENERAL.....	17
2.1.1 Displays and Cleaning.....	17
2.1.2 Environmental Specifications	17
2.2 UNPACKING	17
2.3 INSTALLING MODULES.....	18
2.3.1 I/O Module Planning.....	18
2.3.2 I/O Module and Memory Module Installation Procedure	19
2.4 MOUNTING	22
SECTION 2 - POWER, GROUNDING, AND BUILT-IN I/O CONNECTIONS	
3.1 GENERAL.....	25
3.2 CONNECTION GUIDELINES.....	25
3.3 POWER CONNECTIONS	28

CONTENTS

CONTENTS (Cont'd)

	Page
3.4	GROUND CONNECTIONS 29
3.4.1	Chassis and Shield Grounds 29
3.4.2	Circuit Common Connections 29
3.4.3	Electrical Noise 29
3.4.4	Noise Prevention Measures..... 30
3.5	BUILT-IN PROCESS INPUT CONNECTIONS 31
3.5.1	Built-In Voltage, Millivolt and Thermocouple Inputs 32
3.5.2	Built-In RTD Input 33
3.5.3	Built-In Current Input - 2-Wire Transmitter..... 34
3.5.4	Built-In Current Input - Non 2-Wire Transmitter 35
3.5.5	Built-In Resistance Input..... 36
3.6	BUILT-IN OUTPUT CONNECTIONS..... 37
SECTION 4 - MODULAR I/O CONNECTIONS	
4.1	GENERAL 39
4.2	MODULAR I/O CONNECTION GUIDELINES 39
4.3	MODULAR PROCESS INPUT CONNECTIONS 40
4.3.1	2013A Thermocouple Input (TIM) and Cold Junction Compensation..... 41
4.3.2	2004A SSR Input (DIM) 43
4.3.3	2006A Nonisolated Digital Input (DIM) 45
4.3.4	2002A and 2012A Current Inputs (VCIM)..... 46
4.3.5	2001A Voltage Input (VCIM)..... 48
4.3.6	2009A RTD Input (RIM, WRIM) 49
4.3.7	2020N Remote I/O Interface Module (RIO) 51
4.4	MODULAR OUTPUT CONNECTIONS..... 53
4.4.1	2003A Current Output (AOM) 53
4.4.2	2005A SSR Output (DOM) 54
4.4.3	2007A Nonisolated Digital Output (DOM)..... 56
4.4.4	2011A Dual Mechanical Relay Outputs (DDOM)..... 57
4.4.5	2011A Form C Mechanical Relay Outputs (WDOM) 58
SECTION 5 - COMMUNICATIONS CONNECTIONS	
5.1	GENERAL 59
5.2	COMMUNICATION CONNECTION GUIDELINES..... 60
5.3	FRONT PANEL RS-232 COMMUNICATIONS CONNECTION..... 61
5.4	INSTRUMENT COMMUNICATIONS NETWORK (ICN) CONNECTIONS 61
5.4.1	Cable Requirements 61
5.4.2	Addresses..... 61
5.4.3	Termination 64
5.5	MODBUS NETWORK CONNECTIONS 64
5.5.1	General 64
5.5.2	RS-232 Modbus Communication..... 65
5.5.3	RS-485 2-Wire Modbus Communication 67
5.5.4	RS-485 4-Wire Modbus Communication 69
APPENDIX A	
A.1	MAINTENANCE A-1
A.2	PLANNING FORMS..... A-1

ILLUSTRATIONS

Figure		Page
1-1	Location of Controller Components	2
2-1	Example of an I/O Planning Form for a Controller with I/O Modules	21
2-2	Controller Mounting Dimensions.....	23
3-1	Electrical Connection Terminals	26
3-2	Terminal Identifications for Built-in I/O.....	31
3-3	Built-in Voltage, Millivolt and Thermocouple Input Connections.....	32
3-4	Built-in RTD Input Connections	33
3-5	Built-in 2-Wire Milliampere Current Input Connections.....	34
3-6	Built-in Non 2-Wire Current Input Connections	35
3-7	Built-In Resistance Input Connections.....	36
3-8	Built-in Milliampere Output Connections.....	37
3-9	Built-in Voltage Output Connections.....	37
4-1	Terminal Identifications for Modular I/O.....	39
4-2	Typical Connections for a 2013A Thermocouple Input Module, and a 2009A RTD Module for Cold Junction Compensation.....	42
4-3	Typical Connections for a 2004A Solid State Relay Input Module	44
4-4	Typical Connections for a 2006A Nonisolated Digital Input Module	45
4-5	Typical Connections for a 2012A Current Input Module with 2-Wire Transmitter Power	46
4-6	Typical Connections for a 2002A Current Input Module.....	47
4-7	Typical Connections for a 2001A Voltage Input Module.....	48
4-8	Typical Connections for a 2009A 2-Wire or 3-Wire RTD Input Module	50
4-9	Typical Interface Circuit for 2020N Remote I/O Interface Module (RIO)	52
4-10	Typical Connections for a 2003A Current Output Module	53
4-11	Recommended Connection to Solid State Relay.....	54
4-12	Typical Connections for a 2005A Solid State Relay Output Module	55
4-13	Typical Connections for a 2007A Nonisolated Digital Output Module	56
4-14	Typical Connections for a 2011A Mechanical Relay Output Module (Dual SPST, NO/NC)..	57
4-15	Typical Connections for a 2011AZ10200A Mechanical Relay Output Module (Form C).....	58
5-1	Terminal Identifications for Communications Network Connections	59
5-2	Locations for Port 1 Communications Jumper.....	61
5-3	ICN Connections for Built-in and Modular Communication Circuits	63
5-4	Typical Network Connections for Built-In Modbus RS-232 Communication.....	66
5-5	Typical Network Connections for Modular Modbus RS-232 Communication.....	66
5-6	Typical Modbus Connections for an RS-485, 2-Wire Network	68
5-7	Simplified Diagram, 2034N RS-485, 4-Wire Module	70
5-8	Typical Modbus Connections for an RS-485, 4-Wire Network (Slave Controller)	71
5-9	Typical Modbus Connections for an RS-485, 4-Wire Network (Master Controller)	72
5-10	Typical Modbus Connections for a 4-Wire Master with 2-Wire Slaves.....	73

TABLES

Table		Page
2-1	Module Types and Valid Locations.....	20
4-1	Temperature Range Limits for Thermocouple Input Modules	42
4-2	Supported RTD Materials and Standards and Sample RTDs	49
4-3	Supported Remote I/O Modules	51

CONTENTS

1

PRODUCT DESCRIPTION

1.1 OVERVIEW

The MOD 30ML Multiloop Controller, Figure 1-1, is a 3x6 instrument with a 7 line 3 bar graph configurable display, removable rear terminations, built-in communications, two built-in analog inputs and two outputs, room for eleven additional modular I/O positions (single point or remote I/O interface) and an optional memory module.

1.1.1 Features

Instrument

- 3X6 (72mm X 144mm) instrument with behind panel depth of 15.75 inches (400mm)
- Motorola 68302 processor, including on chip RISC communications processor
- Universal ac power supply (85 to 250VAC/ 50 to 400 Hz, 20-50VDC)
- 11 I/O sockets available for process I/O and communications modules
- 64K bytes non volatile database RAM
- Embedded real-time clock with 1ms resolution
- Remote I/O Interface module option which supports up to 100 discrete I/O points.
- A Service Manual switch under the front panel which allows a single point output to be manually adjusted and displayed (Jumper J5 for NEMA 4 as shown in Figure 1-1).
- NEMA 4 option.
- Removable rear terminations.

Portable Memory Module

- Optional plug on module that provides 64K bytes of redundant, removable non volatile RAM for database backup, portability and integrity (allows a data base to be ported from one instrument to another)
- Updated every 50 ms

Process I/O

- Built-in I/O of two direct connected universal analog inputs and two control outputs.
- Single point direct connected I/O modules for wide variety of process signals
- Embedded microprocessor provides high-resolution signal conversion
- Individually opto-isolated to 250Vrms, continuous
- Per-point, configurable fail-safe and power fail/restart settings
- Provide loop power for 2-wire transmitters

Communications

- Built-in communications driver circuitry supporting either the ICN or Extended Modbus communication with other instruments and host devices.
- Modular communications supporting a second communications channel, either ICN or Extended Modbus, via a plug-in module.
- An RS-232 capable port under the front panel permitting easy connection of a portable computer for data base configuration (requires RS-232 be setup on port 1).

Configuration

- Front panel setup of resident control strategies (see operation book).
- Full data base configuration capability using Application Builder software running on a personal computer (see data base reference books).
- Display development for custom user defined displays

PRODUCT DESCRIPTION

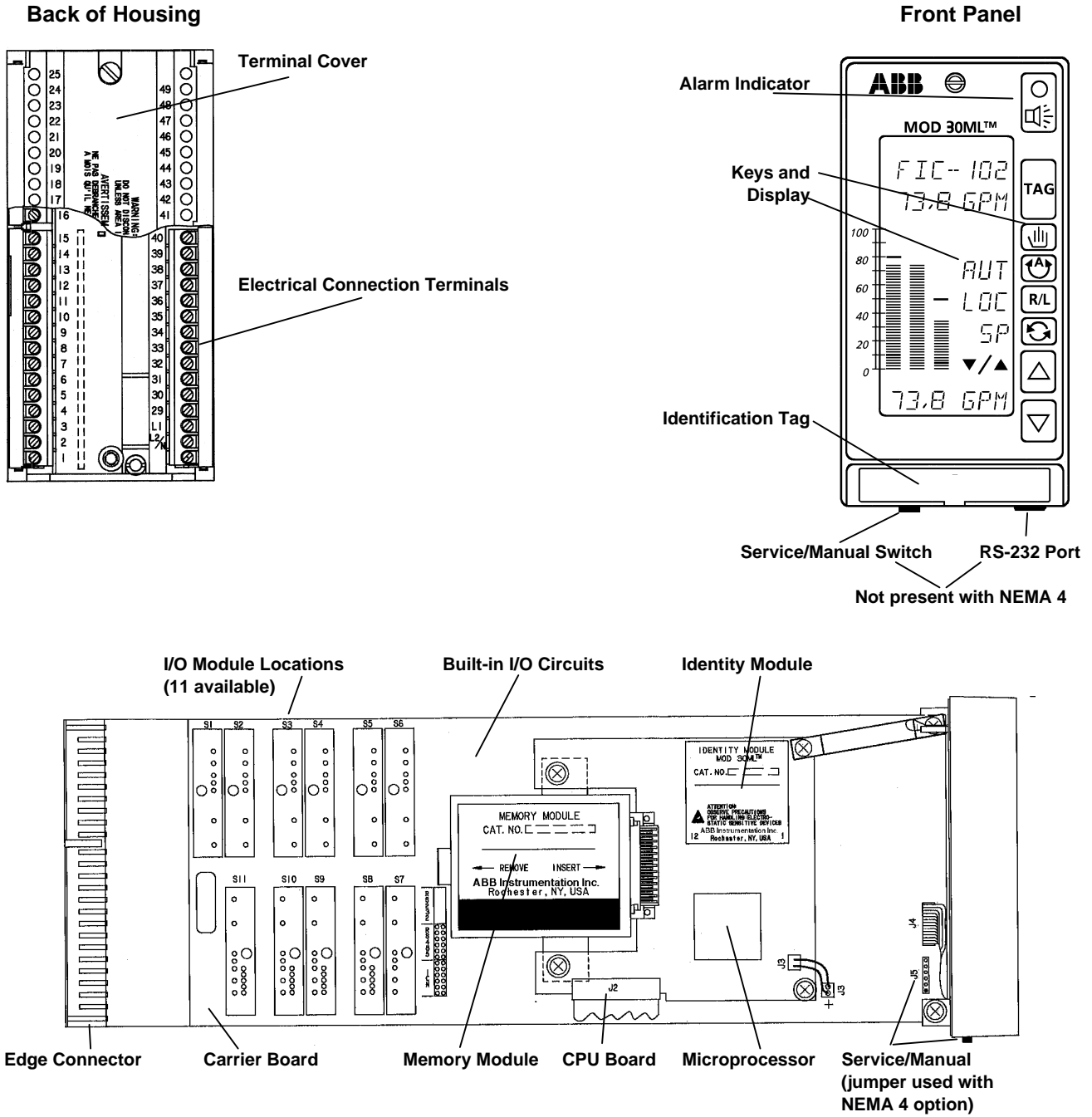

Figure 1-1. Location of Controller Components

1.1.2 Related Documents

Instructions on the operation and setup activities performed at the front panel of this instrument are found in the following document:

- IB-1800R-OPR Operation/Setup Manual

Reference information on the data base structure and configuration parameters for this instrument can be found in the following documents:

- IB-1800R-APP Data Base Reference for MOD 30ML Functions
- IB-23G600 Data Base Reference for Logic, I/O and Communication Functions
- IB-23G601 Data Base Reference for Advanced Control Functions
- IB-23G602 Data Base Reference for Algorithms, Sequencers and Table Functions
- IB-23H141 User's Guide for Application Builder Software

Reference information on ICN/Link communications for this instrument can be found in the following documents.

- IB-23A160 ICN Planning
- IB-23C001 ICN Communication Link Instruction Book for 1720N
- IB-23C003 ICN Mini Link Board Instruction Book for 1731N, 1732N
- IB-23C004 ICN Mini Link External Instruction Book for 1733N, 1732N

The following set of books are supplied as a bound set with the Application Builder Software for the MOD 30ML:

- 98280-418 MOD 30ML Multiloop Controller User's Guide (includes binder, tabs, IB-1800R-INS, IB-1800R-OPR, IB-1800R-APP, IB-23G600, IB-23G601, IB-23G602 and IB-23A160)

1.2 EXPLANATION OF CATALOG NUMBERS

1.2.1 General

The products described in this book have catalog numbers that help identify specific features. In addition, some products are assigned a serial number which can be used to track manufacturing data. The general format of the catalog number is described in this section. Specific product descriptions are provided in the following sections.

The catalog number stamped on the product data plate contains a series of single and multiple-character codes. These codes provide specific information concerning various electrical and/or structural options. Certain code combinations are not allowed, and options and combinations are subject to change. An example of a typical catalog number is as follows:

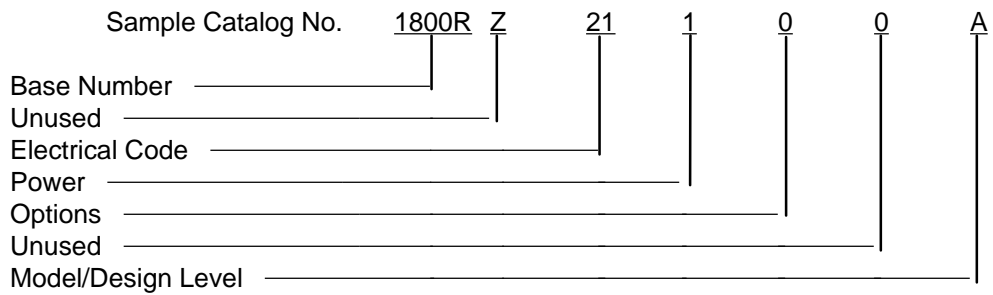

1.2.2 Electrical Codes

Code 21 - FM Approved and CSA Certified

The Electrical Code 21 form of the 1800R MOD 30ML Controller is Factory Mutual (FM) Approved and Canadian Standards Association (CSA) Certified for installation in Class I, Division 2, Groups A, B, C or D Hazardous (Classified) locations. This Approval/Certification includes all modules described in **Sections 1.3, 1.4, and 1.5**, and listed in Table 2-1.

Code 12 - EU EMC Compliant

The Electrical Code 12 form of the 1800R MOD 30ML Controller complies with the requirements for European Union (EU) Electromagnetic Compatibility (EMC) when installed in accordance with the instructions in **Sections 2, 3, 4, and 5**. This compliance includes all modules described in **Sections 1.3, 1.4, and 1.5**, and listed in Table 2-1.

1.3 BASIC HARDWARE

1.3.1 1800R MOD 30ML MULTILoop CONTROLLER

The 1800R, Figure 1-1, is designed for mounting in a panel with a 15.75-inch depth. The instrument housing contains a 50-point termination facility which accepts all instrument I/O, communications, and power connections. A separate grounding stud provides a safety ground connection. This assembly is designed to allow termination signal entry from either top or bottom, allowing for flexibility in signal separation for wiring considerations. The instrument connects to the terminals via an edge connector at the back of the carrier board, permitting interchangeability without disconnecting field wiring.

The carrier board provides the connection locations for the modular I/O. There are eleven locations for single width I/O modules. Ten of the locations are arranged in pairs to accept as many as five double width modules. The carrier board also contains the built-in I/O and communications circuits. Two direct connected analog inputs accept thermocouple, RTD, millivolt and volt dc, milliamp dc and resistance inputs. A 24V dc transmitter power supply for 2-wire transmitters is available on both inputs. Two outputs provide either a 20 mA dc signal or a 50 mA dc signal. The built-in communications circuits terminate in five multi-purpose terminals which permit connection to any of the following networks: ICN, RS-232 Modbus, and 2-wire or 4-wire RS-485 Modbus.

The instrument CPU is based on the 16MHZ 68302 microprocessor. An identity module (1800P) provides the functionality that gives the instrument the capability to execute a user-configured database. The CPU supports 64K bytes of nonvolatile RAM for database storage, and a time-of-day clock with battery support. A high speed communications channel is used between the CPU and both the built-in I/O and any I/O modules installed on the instrument. The CPU board provides for connection of a plug-in memory module.

Catalog Number Description for 1800R

BASE NUMBER	1800R	MOD 30ML Multiloop Controller
	1801R	MOD 30ML Multiloop Controller (narrow bezel)
UNUSED	Z	Unused Character
ELECTRICAL CODE	10	General Purpose, ABB standard
	12	General Purpose, EU EMC Compliant
	21	FM Approved and CSA Certified Class I, Division 2, Groups A, B, C, D
POWER SUPPLY	0	24 Vdc (20 – 50 Vdc)
	1	85 – 250 Vac, 50 – 400 Hz
OPTIONS	0	None
	1	MOD 30 Termination Assembly (see IB-1800R-M30)
	2	Option 1 plus: (see IB-1800R-M30) <ul style="list-style-type: none"> • 1 Voltage Input Module • 2 Non-Isolated Digital Input Modules • 3 Non-Isolated Digital Output Modules
	3	NEMA 4
UNUSED	0	Unused Character
MODEL	A	Design Level A
	B	Design Level B (EU EMC Compliant)
Sample Number	1800RZ21100A (Product is serialized)	

PRODUCT DESCRIPTION**1.3.2 1800P MOD 30ML Identity Module**

The identity module, Figure 1-1, gives the instrument a specific level of process and communications functionality. The 1800P module is factory installed and provides the capability to execute a user-configured database which consists of built-in and modular I/O handling capabilities, PID functionality, and a collection of other control related functions. These include process alarms, input signal linearization, timers, totalization, signal selection, lead/lag filtering, dead time compensation, and automatic tuning. These functions reside in a group of basic data base elements called function blocks.

Catalog Number Description for 1800P

BASE NUMBER	1800P	MOD 30ML Identity Module
UNUSED	Z	Unused Character
ELECTRICAL CODE	10	General Purpose, ABB standard
FUNCTION	1	Advanced Control
FIRMWARE VERSION	01 02	Version 1 Version 2
MODEL	A C	Design Level A Design Level C
Sample Number	1800PZ10102C (Product is serialized)	

1.3.3 2010P MODCELL Memory Module

The optional memory module plugs directly into the CPU board, Figure 1-1, and provides a mechanism for porting a database from one instrument to another. An instrument with this option can upload from or download to this module. The memory module has a write protect setting to prevent accidental erasures. When a memory module is installed in an instrument with the write protection off, the operating software keeps the module up-to-date with all real time changes in the instrument. Enhanced security is thereby provided through this backup database copy. Data retention is typically 10 years with instrument unpowered.

Catalog Number Description for 2010P

BASE NUMBER	2010P	Memory Module
UNUSED	Z	Unused Character
ELECTRICAL CODE	10	General Purpose, ABB standard
UNUSED	000	Unused Characters
MODEL	A	Design Level
Sample Number	2010PZ10000A (Product is serialized)	

1.4 I/O MODULES

The descriptions included in this section give a brief overview of the functions and features of the I/O modules.

1.4.1 2001A Voltage Input Module

The voltage input module provides dual ranges of $\pm 10\text{V}$ dc and $\pm 100\text{ mV}$ dc selectable by configuration. Input to the module is scaled and then applied to an integrating analog to digital converter. Line cycle integration can be performed at either 50 or 60 Hz line frequencies to reject any line frequency noise. Transformer isolation from the +5 volt supply is used to derive all the internal voltages to run the isolated front end. Optical isolation is used to transfer the information from the A/D converter serially to the microprocessor. The microprocessor takes the raw A/D voltage, compares it to the reference, and then presents it to the host as requested over the serial communications bus. This module uses the Voltage/Current Input Module (VCIM) Block for configuration of input parameters.

VCIM

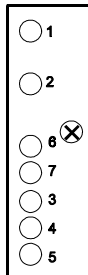

Catalog Number Description for 2001A

BASE NUMBER	2001A	Voltage Input Module
UNUSED	Z	Unused Character
ELECTRICAL CODE	10	General Purpose, ABB standard
INPUT RANGE	10	$\pm 100\text{ mV}$ or $\pm 10\text{ Vdc}$
ISOLATION	1	Isolated
MODEL	B	Design Level
Sample Number	2001AZ10101B	

1.4.2 2002A Current Input Module

The current input module is identical to the voltage input module except for the addition of a 250 ohm resistor across the two input leads. This allows the standard 4-20 mA DC input range to be accommodated by the module. This module uses the Voltage/Current Input Module (VCIM) Block for configuration of input parameters.

VCIM

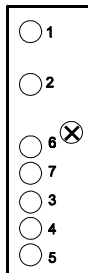

Catalog Number Description for 2002A

BASE NUMBER	2002A	Current Input Module
UNUSED	Z	Unused Character
ELECTRICAL CODE	10	General Purpose, ABB standard
INPUT RANGE	10	4 – 20 mA
ISOLATION	1	Isolated
MODEL	B	Design Level
Sample Number	2002AZ10101B	

1.4.3 2012A Current Input Module (with 2-wire transmitter power)

This module is designed specifically for two-wire transmitters and provides the necessary 24 V DC current limited supply to power the transmitter. An internal current sense resistor converts the current to a voltage for application to the A/D converter. All other features are the same as the voltage input module. This module uses the Voltage/Current Input Module (VCIM) Block for configuration of input parameters.

VCIM

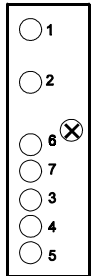

Catalog Number Description for 2012A		
BASE NUMBER	2012A	Current Input Module (with 2-wire transmitter power)
UNUSED	Z	Unused Character
ELECTRICAL CODE	10	General Purpose, ABB standard
INPUT RANGE	10	4 – 20 mA
ISOLATION	1	Isolated
MODEL	B	Design Level
Sample Number	2012AZ10101B	

1.4.4 2013A Thermocouple Input Module (with upscale burnout detecton)

The thermocouple input module is identical to the ±100 mV voltage input module except for the addition of upscale burnout detection circuitry. Thermocouple types allowed are: B, E, J, K, N, S, or T. This module uses the Thermocouple Input Module (TIM) Block for configuration of input parameters.

Cold junction compensation (CJC) for all thermocouples is provided automatically by the controller when this feature is enabled by connection of a thermocouple to built-in input 1. If automatic CJC is not enabled, a 2009A RTD Input Module with a 2-wire CJC sensor must be used to sense the temperature at the terminal block and provide CJC.

TIM

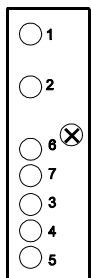

Catalog Number Description for 2013A		
BASE NUMBER	2013A	Thermocouple Input Module (with upscale burnout detecton)
UNUSED	Z	Unused Character
ELECTRICAL CODE	10	General Purpose, ABB standard
INPUT RANGE	10	±100 mV
ISOLATION	1	Isolated
MODEL	B	Design Level
Sample Number	2013AZ10101B	

1.4.5 2003A Current Output Module

The current output module provides an isolated 0-20 mA or 4-20 mA current output. An internal A/D converter reads back the output value to check for open outputs or broken wires. This module uses the Analog Output Module (AOM) Block for configuration of output parameters.

AOM

<input type="radio"/> 1
<input type="radio"/> 2
<input checked="" type="radio"/> 6
<input type="radio"/> 7
<input type="radio"/> 3
<input type="radio"/> 4
<input type="radio"/> 5

Catalog Number Description for 20033A

BASE NUMBER	2003A	Current Output Module
UNUSED	Z	Unused Character
ELECTRICAL CODE	10	General Purpose, ABB standard
OUTPUT RANGE	10	4 – 20 mA
ISOLATION	1	Isolated
MODEL	A	Design Level
Sample Number	2003AZ10101A	

PRODUCT DESCRIPTION

1.4.6 2004A Solid-State Relay Input Module

The Solid-State Relay Input module provides the necessary interfacing for AC or DC digital inputs when high isolation voltages are required (250V rms isolation limitation through connection terminals). This module uses the Digital Input Module (DIM) Block for configuration of input parameters.

DIM

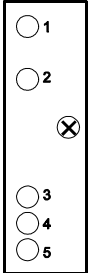

Catalog Number Description for 2006A

BASE NUMBER	2006A	Nonisolated Digital Input Module
UNUSED	Z	Unused Character
ELECTRICAL CODE	10	General Purpose, ABB standard
INPUT RANGE	10	2.5 to 28 VDC
	11	4 to 16 VDC
	12	10 to 32 VDC, 12 to 32 VAC
	13	35 to 60 VAC / VDC
	14	90 to 140 VAC / VDC
	15	180 to 280 VAC / VDC
UNUSED	0	Unused Character
MODEL	A	Design Level
Sample Number	2004AP10100A	

1.4.7 2005A Solid-State Relay Output Module

The Solid-State Relay Output module provides the necessary interfacing for AC or DC digital outputs when high isolation voltages are required (250V rms isolation limitation through connection terminals). This module uses the Digital Output Module (DOM) Block for configuration of output parameters.

DOM

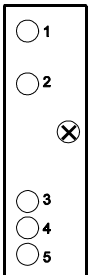

Catalog Number Description for 2006A

BASE NUMBER	2006A	Nonisolated Digital Input Module
UNUSED	Z	Unused Character
ELECTRICAL CODE	10	General Purpose, ABB standard
OUTPUT RANGE	10	5 to 60 VDC
	11	5 to 200 VDC
	12	12 to 140 VAC, SPST, NO
	13	24 to 280 VAC, SPST, NO
	14	24 to 280 VAC, SPST, NC
UNUSED	0	Unused Character
MODEL	A	Design Level
Sample Number	2005AP10100A	

PRODUCT DESCRIPTION**1.4.8 2006A Nonisolated Digital Input Module**

The Nonisolated Digital Input Module is primarily intended for instrument-to-instrument signaling. The module interfaces 24-volt on/off signals with no isolation or accepts switch contact closures without external power requirements. This module uses the Digital Input Module (DIM) Block for configuration of input parameters.

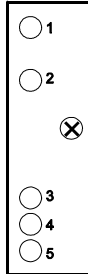
DIM**Catalog Number Description for 2006A**

BASE NUMBER	2006A	Nonisolated Digital Input Module
UNUSED	Z	Unused Character
ELECTRICAL CODE	10	General Purpose, ABB standard
INPUT RANGE	10	2.2 V to 24 VDC
UNUSED	0	Unused Character
MODEL	A	Design Level
Sample Number	2006AZ10100A	

1.4.9 2007A Nonisolated Digital Output Module

The Nonisolated Digital Output Module is primarily intended for instrument-to-instrument signaling. The module interfaces 24-volt on/off signals with no isolation or works as an open collector switch that also supports 5V TTL. This module uses the Digital Output Module (DOM) Block for configuration of output parameters.

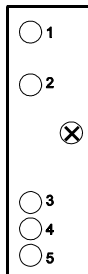
DOM**Catalog Number Description for 2007A**

BASE NUMBER	2007A	Nonisolated Digital Output Module
UNUSED	Z	Unused Character
ELECTRICAL CODE	10	General Purpose, ABB standard
OUTPUT RANGE	10	24 V, 50 mA TTL
UNUSED	0	Unused Character
MODEL	A	Design Level
Sample Number	2007AZ10100A	

PRODUCT DESCRIPTION

1.4.10 2011A Mechanical Relay Output Module

The Mechanical Relay Output Module may have dual SPST relays or a Form C relay. This module uses the Dual Digital Output Module (DDOM) Block for configuration of dual SPST output parameters or the Wide Digital Output Module (WDOM) Block for configuration of Form C output parameters.

**DDOM
WDOM**

<input type="radio"/> 1	<input type="radio"/> 13
<input type="radio"/> 2	<input type="radio"/> 14
	<input checked="" type="radio"/> 15
<input type="radio"/> 3	<input type="radio"/> 16
<input type="radio"/> 4	<input type="radio"/> 17
<input type="radio"/> 5	

Catalog Number Description for 2011A

BASE NUMBER	2011A	Mechanical Relay Output Module
UNUSED	Z	Unused Character
ELECTRICAL CODE	10	General Purpose, ABB standard
TYPE	10	Dual SPST, NO/NO
	11	Dual SPST, NC/NC
	12	Dual SPST, NO/NC
	20	Form C
UNUSED	0	Unused Character
MODEL	A	Design Level
Sample Number	2011AZ10100A	

1.4.11 2009A RTD Input Module

The RTD Input Module is available in two basic forms, 2-wire 0 to 4000 ohm (single wide) and 3-wire 0 to 400 ohm (double wide). RTD sensors use the Wide Resistance Input Module (WRIM) Block for configuration of 3-wire input parameters and the Resistance Input Module (RIM) Block for configuration of 2-wire input parameters.

RIM

<input type="radio"/> 1
<input type="radio"/> 2
<input checked="" type="radio"/> 6
<input type="radio"/> 7
<input type="radio"/> 3
<input type="radio"/> 4
<input type="radio"/> 5

Catalog Number Description for 2009A

BASE NUMBER	2009A	RTD Input Module
UNUSED	Z	Unused Character
ELECTRICAL CODE	10	General Purpose, ABB standard
REF. RESISTANCE	1	100 Ohm (3-wire 0 to 400 only)
	2	1000 Ohm (2-wire 0 to 4000 only)

WRIM

<input type="radio"/> 1	<input type="radio"/> 13
<input type="radio"/> 2	<input type="radio"/> 14
	<input checked="" type="radio"/> 15
<input type="radio"/> 6	
<input type="radio"/> 7	
<input type="radio"/> 3	
<input type="radio"/> 4	
<input type="radio"/> 5	

CONNECTION	2	2-Wire (0 to 4000 Ohm)
	3	3-Wire (0 to 400 Ohm)
	4	2-Wire CJC Sensor (1000 ohm RTD, Table 4-2)
MODEL	B	Design Level
Sample Number	2009AZ10130B	

1.4.12 2020N Remote I/O Interface Module

Remote Input and Output Modules expand the I/O capability of a MOD 30ML Multiloop Controller to a total of 100 discrete points. The remote modules communicate to the controller over the CS-31 Remote I/O Network, an RS-485 bus which connects the remote I/O base units to the 2020N Remote I/O plug-in module. This module is not required to reside in a communications slot, leaving the two communications channels on the controller open for host or peer-to-peer communications. See **Section 4.3.7** for remote I/O interface connections. Remote I/O digital connections are described in **IB-23C601**. This module uses the RIO block for configuration.

<p>RIO</p> <div style="border: 1px solid black; padding: 5px; display: inline-block;"> <table border="0" style="font-size: small;"> <tr><td><input type="radio"/> 1</td><td><input type="radio"/> 13</td></tr> <tr><td><input type="radio"/> 2</td><td><input type="radio"/> 14</td></tr> <tr><td><input type="radio"/> 6</td><td><input checked="" type="radio"/> 15</td></tr> <tr><td><input type="radio"/> 7</td><td><input type="radio"/> 15</td></tr> <tr><td><input type="radio"/> 3</td><td><input type="radio"/> 17</td></tr> <tr><td><input type="radio"/> 4</td><td><input type="radio"/> 17</td></tr> <tr><td><input type="radio"/> 5</td><td></td></tr> </table> </div>	<input type="radio"/> 1	<input type="radio"/> 13	<input type="radio"/> 2	<input type="radio"/> 14	<input type="radio"/> 6	<input checked="" type="radio"/> 15	<input type="radio"/> 7	<input type="radio"/> 15	<input type="radio"/> 3	<input type="radio"/> 17	<input type="radio"/> 4	<input type="radio"/> 17	<input type="radio"/> 5		<p>Catalog Number Description for 2020N</p> <table border="0" style="font-size: small;"> <tr> <td style="padding-right: 20px;">BASE NUMBER</td> <td style="padding-right: 20px;">2020N</td> <td>Remote I/O Interface Module</td> </tr> <tr> <td>UNUSED</td> <td>Z</td> <td>Unused Character</td> </tr> <tr> <td>ELECTRICAL CODE</td> <td>10</td> <td>General Purpose, ABB standard</td> </tr> <tr> <td>UNUSED</td> <td>000</td> <td>Unused Character</td> </tr> <tr> <td>MODEL</td> <td>B</td> <td>Design Level</td> </tr> <tr> <td>Sample Number</td> <td>2020NZ10000B</td> <td></td> </tr> </table>	BASE NUMBER	2020N	Remote I/O Interface Module	UNUSED	Z	Unused Character	ELECTRICAL CODE	10	General Purpose, ABB standard	UNUSED	000	Unused Character	MODEL	B	Design Level	Sample Number	2020NZ10000B	
<input type="radio"/> 1	<input type="radio"/> 13																																
<input type="radio"/> 2	<input type="radio"/> 14																																
<input type="radio"/> 6	<input checked="" type="radio"/> 15																																
<input type="radio"/> 7	<input type="radio"/> 15																																
<input type="radio"/> 3	<input type="radio"/> 17																																
<input type="radio"/> 4	<input type="radio"/> 17																																
<input type="radio"/> 5																																	
BASE NUMBER	2020N	Remote I/O Interface Module																															
UNUSED	Z	Unused Character																															
ELECTRICAL CODE	10	General Purpose, ABB standard																															
UNUSED	000	Unused Character																															
MODEL	B	Design Level																															
Sample Number	2020NZ10000B																																

1.5 COMMUNICATIONS MODULES

The descriptions included in this section give a brief overview of the functions and features of the communication modules. These modules can be used to add a second communication channel to the MOD 30ML.

1.5.1 2030N ICN Communication Module

The ICN Communication module provides Instrument Communication Network (ICN) communications capability for the MOD 30ML Multiloop Controller. The ICN is a proprietary network that allows peer-to-peer communications between the controllers and can be used with the MOD 30 Instrument line. It also uses a communication link to a computer running the Application Builder or PC30 series software or other operator interface software. The ICN Baud rate is 31,250 bits per second. The Model B ICN requires an external terminator such as the 2030F ICN Terminator.

<p>ICN</p> <div style="border: 1px solid black; padding: 5px; display: inline-block;"> <table border="0" style="font-size: small;"> <tr><td><input type="radio"/> 1</td><td><input type="radio"/> 13</td></tr> <tr><td><input type="radio"/> 2</td><td><input type="radio"/> 14</td></tr> <tr><td><input type="radio"/> 6</td><td><input checked="" type="radio"/> 15</td></tr> <tr><td><input type="radio"/> 7</td><td><input type="radio"/> 15</td></tr> <tr><td><input type="radio"/> 3</td><td><input type="radio"/> 16</td></tr> <tr><td><input type="radio"/> 4</td><td><input type="radio"/> 17</td></tr> <tr><td><input type="radio"/> 5</td><td></td></tr> </table> </div>	<input type="radio"/> 1	<input type="radio"/> 13	<input type="radio"/> 2	<input type="radio"/> 14	<input type="radio"/> 6	<input checked="" type="radio"/> 15	<input type="radio"/> 7	<input type="radio"/> 15	<input type="radio"/> 3	<input type="radio"/> 16	<input type="radio"/> 4	<input type="radio"/> 17	<input type="radio"/> 5		<p>Catalog Number Description for 2030N</p> <table border="0" style="font-size: small;"> <tr> <td style="padding-right: 20px;">BASE NUMBER</td> <td style="padding-right: 20px;">2030N</td> <td>ICN Communication Module</td> </tr> <tr> <td>UNUSED</td> <td>Z</td> <td>Unused Character</td> </tr> <tr> <td>ELECTRICAL CODE</td> <td>10</td> <td>General Purpose, ABB standard</td> </tr> <tr> <td>UNUSED</td> <td>000</td> <td>Unused Character</td> </tr> <tr> <td>MODEL</td> <td>B</td> <td>Design Level</td> </tr> <tr> <td>Sample Number</td> <td>2030NZ10000B</td> <td></td> </tr> </table>	BASE NUMBER	2030N	ICN Communication Module	UNUSED	Z	Unused Character	ELECTRICAL CODE	10	General Purpose, ABB standard	UNUSED	000	Unused Character	MODEL	B	Design Level	Sample Number	2030NZ10000B	
<input type="radio"/> 1	<input type="radio"/> 13																																
<input type="radio"/> 2	<input type="radio"/> 14																																
<input type="radio"/> 6	<input checked="" type="radio"/> 15																																
<input type="radio"/> 7	<input type="radio"/> 15																																
<input type="radio"/> 3	<input type="radio"/> 16																																
<input type="radio"/> 4	<input type="radio"/> 17																																
<input type="radio"/> 5																																	
BASE NUMBER	2030N	ICN Communication Module																															
UNUSED	Z	Unused Character																															
ELECTRICAL CODE	10	General Purpose, ABB standard																															
UNUSED	000	Unused Character																															
MODEL	B	Design Level																															
Sample Number	2030NZ10000B																																

PRODUCT DESCRIPTION

1.5.2 2032N RS-485 Communication Module for Modbus (2-Wire)

This RS-485 Communication module is a bidirectional transceiver that provides 2-wire Modbus communications capability for the instrument. This module can be used for either a point-to-point or point-to-multipoint network. The Modbus communications supported by this module are used only for reading and writing controller attributes.

MSC

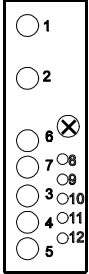

Catalog Number Description for 2032N

BASE NUMBER	2032N	RS-485 Communication Module for Modbus (2-Wire)
UNUSED	Z	Unused Character
ELECTRICAL CODE	10	General Purpose, ABB standard
UNUSED	000	Unused Character
MODEL	C	Design Level (optically isolated)
Sample Number	2032NZ10000C	

1.5.3 2033N RS-232 Communication Module for Modbus

The RS-232 Communication module is a driver/receiver that provides Extended Modbus communications capability for the instrument. The RS-232 module can be used for a point-to-point Modbus network. The Extended Modbus communications supported by this module include data base downloading, reading diagnostics, reading the system event queue, and reading and writing controller attributes.

MSC

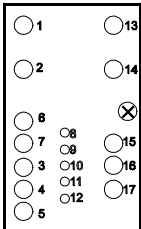

Catalog Number Description for 2033N

BASE NUMBER	2033N	RS-232 Communication Module for Modbus
UNUSED	Z	Unused Character
ELECTRICAL CODE	10	General Purpose, ABB standard
UNUSED	000	Unused Character
MODEL	A	Design Level
Sample Number	2033NZ10000A	

1.5.4 2034N RS-485 Communication Module for Modbus (4-Wire)

This RS-485 Communication module contains a driver and receiver that provide Extended Modbus communications capability for the instrument. This module can be used for either a point-to-point or point-to-multipoint Modbus network. The Extended Modbus communications supported by this module include data base downloading, reading diagnostics, reading the system event queue, and reading and writing controller attributes.

MSC

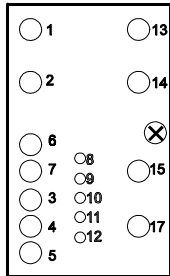

Catalog Number Description for 2034N

BASE NUMBER	2034N	RS-485 Communication Module for Modbus (4-Wire)
UNUSED	Z	Unused Character
ELECTRICAL CODE	10	General Purpose, ABB standard
UNUSED	000	Unused Character
MODEL	A	Design Level
Sample Number	2034NZ10000A	

1.5.5 2030F ICN Terminator

The ICN Terminator is used to provide a termination scheme for an ICN network. One termination is required per ICN.

Catalog Number Description for 2030F

BASE NUMBER	2030F	ICN Terminator
UNUSED	Z	Unused Character
Unused	0000	Unused Characters
FORMAT 2Flush Mount	1	Eurocard or 1800R
MODEL	A	Design Level
Sample Number	2030FZ10100A	

PRODUCT DESCRIPTION

2 MECHANICAL INSTALLATION

2.1 GENERAL

Read these instructions thoroughly before starting installation. Installation personnel should be qualified technicians.

Mechanical installation involves:

- Unpacking (**Section 2.2**)
- Planning and Installing optional I/O and memory modules if these items are being used (**Section 2.3**)
- Mounting (**Section 2.4**)

2.1.1 Displays and Cleaning

The display is protected by an overlay that can be removed after installation. The face of the display, while made of scratch-resistant plastic, can be abraded by harsh materials such as paper towels and industrial wipes. Lens cleaning tissues and soft cloths are suitable for cleaning displays. Remove dust from the rear of the instrument by removing it from the instrument housing and spraying exposed surfaces with non-corrosive, non-toxic, non-flammable inert dusting gas.

2.1.2 Environmental Specifications

Operating Temperature:	0 to +50°C (32 to 122°F)		
Storage Temperature:	-40 and +75°C (-40 and 167°F)		
Humidity	5 to 95 % RH, non condensing		
Altitude:	2000 meters max		
Ingress Protection:	Options 0,1,2	Front: IP22	Rear: IP20
	Option3 (NEMA 4)	Front: IP56	Rear: IP20
Pollution degree:	2		

2.2 UNPACKING

Unpack and visually inspect the instrument housing, controller, and associated modules for any damage. The instrument may be removed from its housing, if necessary, to install modules or change the communication jumper. Remove the controller from its housing by loosening the two retaining screws in the front panel and pulling the unit out of the housing. Save packing materials for any reshipment, or to support any claim of shipment damage. All damage claims are made against the carrier and are the responsibility of the customer.

Included in the shipping container is a bag containing mounting brackets and screws, and an information package. A card containing several copies of a writeable instrument identification tag is included in the information package. Write required data on the tag and insert it under the translucent strip at the bottom of the front panel after the controller is installed.

MECHANICAL INSTALLATION

2.3 INSTALLING MODULES

The controller can accommodate as many as eleven I/O modules. These optional plug-in modules expand the built-in I/O capacity of the controller. An optional memory module is also available. The I/O modules mount on the carrier board, and the memory module mounts on the CPU board as shown in Figure 1-1. The modules must be installed before placing the controller into operation.

2.3.1 I/O Module Planning

In general there is a high degree of flexibility in locating the I/O modules. The only specific location restrictions are as follows:

- Field I/O circuits for locations S7 through S11 must not operate at voltages above 30V rms, 42.4V peak, or 60V dc to comply with safety approval/certification requirements.
- Communications modules have a dedicated location determined by the communications port being used.
- There are special requirements for the 2003A current output module and the 2012A active current input module. Because of the heat generated by these modules, they must be installed in a slot that has no module in either adjacent slot. Slot 11 may be used as long as slot 10 is not a 2003A or a 2012A.
- To guarantee the accuracy of the built-in cold junction compensator, when used, there should be no module in slots 1 or 2 and no 2003A or 2012A in slots 3, 4 or 11.

Table 2-1 lists the available I/O module types, their associated data base memory block identifications, and the valid locations for each module type. An I/O planning form is provided to document the planned I/O configuration. An example of the form, listing built-in I/O assignments and the module layout for a controller with five I/O modules, is shown in Figure 2-2. See **Appendix A** for a blank copy of all planning forms.

⚠WARNING *Do not use any I/O module which is not listed in Table 2-1. When used in MOD 30ML systems, the listed modules are FM Approved and CSA Certified for use in Class I, Division 2, Group A, B, C or D hazardous (classified) locations. Substitution of a module not on the list voids the Approval/Certification.*

Some other factors which influence I/O module requirements are as follows:

- If the controller requires thermocouple inputs, the first thermocouple should be connected to built-in input 1 to provide automatic cold junction compensation for all inputs. If automatic cold junction compensation is not enabled, an I/O module must be installed to provide the compensation. See **Section 4.3.1** for more information.
- The layout of module locations on the carrier board, Figure 2-1, divides locations 1 through 10 into pairs allowing double wide modules to occupy only five different locations.
- Communications port 1 serves either the built-in communications circuits or module location S10 (S10 and S9 if module is double wide). If the communications function is being used, connections should first be made to the built-in communication circuit. This leaves module locations S9 and S10 available for other I/O functions. Location S8 (S8 and S7 if module is double wide) is always available for communications via port 2. See **Section 5** for more information.

MECHANICAL INSTALLATION

⚠WARNING *Do not use a 2011A Mechanical Relay Output Module when the installation environment contains chemicals which can degrade the materials used to seal the relay in the module. The sealing materials are as follows:*

- *Polybutylene Terephthalate, Polyplastics Co. Ltd., Compound No. 3270*
- *Polyphelene Suffide, Summitomo Chemical Co. Ltd., Compound No. 3601GL30*
- *Epoxy Resin, Summito Bakelite Co. Ltd., SUMIMAC ECR-9107K*

Degradation of the relay seal voids the Approval/Certification of the instrument for use in Class I, Division 2, Group A, B, C or D hazardous (classified) locations.

The controller power supply has the capacity to handle the base instrument load of 1220 mA plus any mix of built-in and modular I/O loads such that the total current consumption does not exceed 5000 milliamps (5 amps). Add the current consumption for the base instrument, built-in I/O, and each I/O module using the planning form in Appendix A, Verify that the total does not exceed 5000 milliamps.

2.3.2 I/O Module and Memory Module Installation Procedure

Install the modules as follows:

1. Loosen the 2 retaining screws in the front panel, Figure 1-1, and pull the instrument out of its housing.

! CAUTION: Support the instrument from the front and bottom or from the insulator plate whenever the instrument is outside its housing. Do not allow the full weight of the circuit boards to be suspended unsupported from the front panel as this may overstress the brackets at that end.

2. Place the instrument on a flat surface with the front panel overhanging the edge of the surface so that the black insulator plate is firmly supported. This positioning assures that the instrument is not damaged by the force applied when inserting I/O modules.
3. Plug each I/O module into its required location on the carrier board and tighten the retaining screw.
4. Use the memory module as dedcribed in **IB-1800-OPR Operation/Setup Manual**.

* **NOTE:** When installing the memory module it is important to orient it so that the catalog number label is visible when the module is plugged into the connector on the CPU board.

MECHANICAL INSTALLATION

Table 2-1. Module Types and Valid Locations

Module Type	Data Base Block Type	Module Width	Module Location
2001A Voltage Input 2002A Current Input	VCIM	Single	Any Location
2012A Current Input with 2-Wire Transmitter	VCIM	Single	Non-adjacent Locations
2003A Current Output	AOM	Single	Non-adjacent Locations
2004A Solid State Relay Input	DIM	Single	S1 through S6 (Note 1)
2005A Solid State Relay Output	DOM	Single	S1 through S6 (Note 1)
2006A Nonisolated Digital Input	DIM	Single	Any Location
2007A Nonisolated Digital Output	DOM	Single	Any location
2009A RTD Input (2 Wire)	RIM	Single	Any Location
2009A RTD Input (3 Wire)	WRIM	Double	Any pair of Locations
2011A Mechanical Relay Output (SPST) 2011A Mechanical Relay Output (Form C)	DDOM WDOM	Double	S1 & S2, S3 & S4, or S5 & S6 (Note 2)
2013A Thermocouple Input with Upscale Burnout Detection	TIM	Single	Any Location
2020N Remote I/O Interface Module	RIO	Double	Any Pair of Locations
2030N ICN Communication	ICN	Double	S7&S8 (Port 2) or S9&S10 (Port 1) (Note 3)
2032N RS-485 2-Wire Modbus Communication	MSC	Single	S8 (Port 2) or S10 (Port 1) (Note 3)
2033N RS-232 Modbus Communication 2034N RS-485 4-Wire Modbus Communication	MSC	Double	S7 & S8 (Port 2) or S9 & S10 (Port 1) (Note 3)

- * **NOTES:**
1. The maximum working voltage between adjacent terminal of circuits rated less than 30 V rms or 42.4 V peak or 60 Vdc must not be more than 150 V. The maximum working voltage between adjacent terminal of circuits rated greater than 30 V rms or 42.4 V peak or 60 Vdc must not be more than 300 V.
 2. If I/O circuit voltage is 30V rms, 42.4V peak, 60V dc or less, location pairs S7-S8 and S9-S10 can also be used.
 3. If a communications module is installed in location S10, built-in communication drivers are not available.

MOD 30ML I/O PLANNING FORM

Controller No. _____

Built-in I/O

Input 1: Thermocouple - Type J

Output 1: 20 mA

Input 2: mA w/ 24 Vdc Transmitter Power Supply

Output 2: 20 mA

Communications: 4-Wire RS-485 Modbus (port 1)

Modular I/O

I/O Module Locations

No.	Module	No.	Module	No.	Module	No.	Module	No.	Module	No.	Module
S1		S2	2005A	S3	2009A	S4	>-----	S5		S6	2003A
S7	2001A	S8		S9	2012A	S10		S11	2006A		//////////

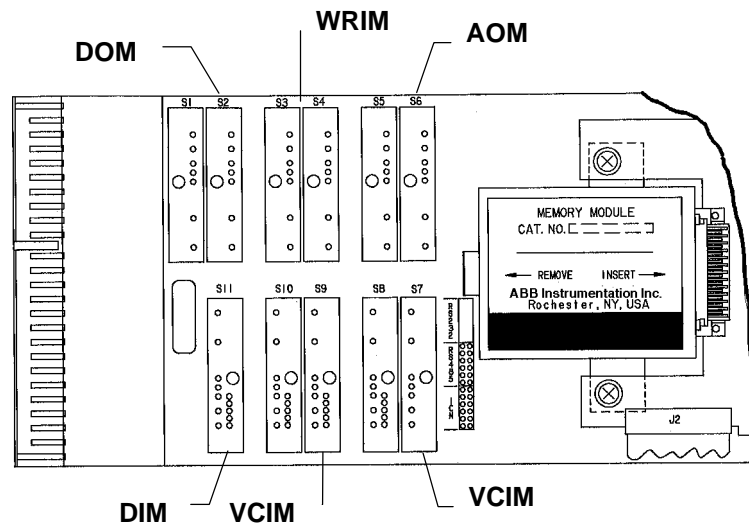

Figure 2-1. Example of an I/O Planning Form for a Controller with I/O Modules

MECHANICAL INSTALLATION

2.4 MOUNTING

The controller must be installed in an approved enclosure or installed in a means acceptable to the authority having jurisdiction for electrical installations.

⚠WARNING <i>Do not install a MOD 30ML controller in a residential, commercial or light industrial environment in the European Union.</i>

Select a mounting location where:

- There is minimum vibration.
- The ambient temperature is between 32 and 122°F (0 and 50°C) with a relative humidity of 5-95% RH (noncondensing). The ambient temperature and humidity requirements apply to the air directly below the controller.
- The installation allows for free air flow above and below the controller
- If it is necessary to mount two or more controllers above each other, and the room ambient temperature is above 70°F, heat generated by the lower instruments may raise the ambient of the upper instruments above the 122°F limit. To assure that operating temperatures are within specified limits, it is recommended that a fan be installed below the instruments to force air circulation over the instruments in an upward direction. Air velocity should be at least 100 to 200 feet per minute.
- The panel provides rigid support for a fully loaded 5.5-pound (2.5 kg) controller and any other panel devices.
- Electrical wiring routing and support are planned.

Mount the controller as follows:

1. Prepare the panel as indicated in Figure 2-2. Be sure to allow enough clearance under the front panel of each controller to access the communications jack in the bottom of the front panel (not present with NEMA 4 option).
2. Draw a 1/4" boundary around cutout for reference when caulking. Apply a 1/4" bead of silicon caulking (Loctite # 59530 or equivalent) on the panel around the cutout.

* **NOTE:** If NEMA 4 is not required, the controller can be installed without the gasket or the caulking.
3. Slide instrument housing only into panel cutout.
4. Insert brackets into slots in top and bottom of instrument housing.
Be sure the housing gasket is not pinched or twisted between the instrument housing and the front of the panel.
5. Tighten retaining screws to a torque of 5 inch-pounds (0.6 Nm) or 1-1/2 turns after contact is made with the back of the panel.
6. Wipe the excess silicon caulking to form a smooth fill and allow it to dry for 24 hours.
7. After the caulking has dried, insert the instrument into the housing and tighten the jack screw(s) to 7 to 10 inch-pounds (0.8 to 1.1 Nm) or 1-1/2 turns after the front face draws into the gasket (two screws for NEMA 4 option, one on top otherwise).

MECHANICAL INSTALLATION

MOUNTING DIMENSIONS

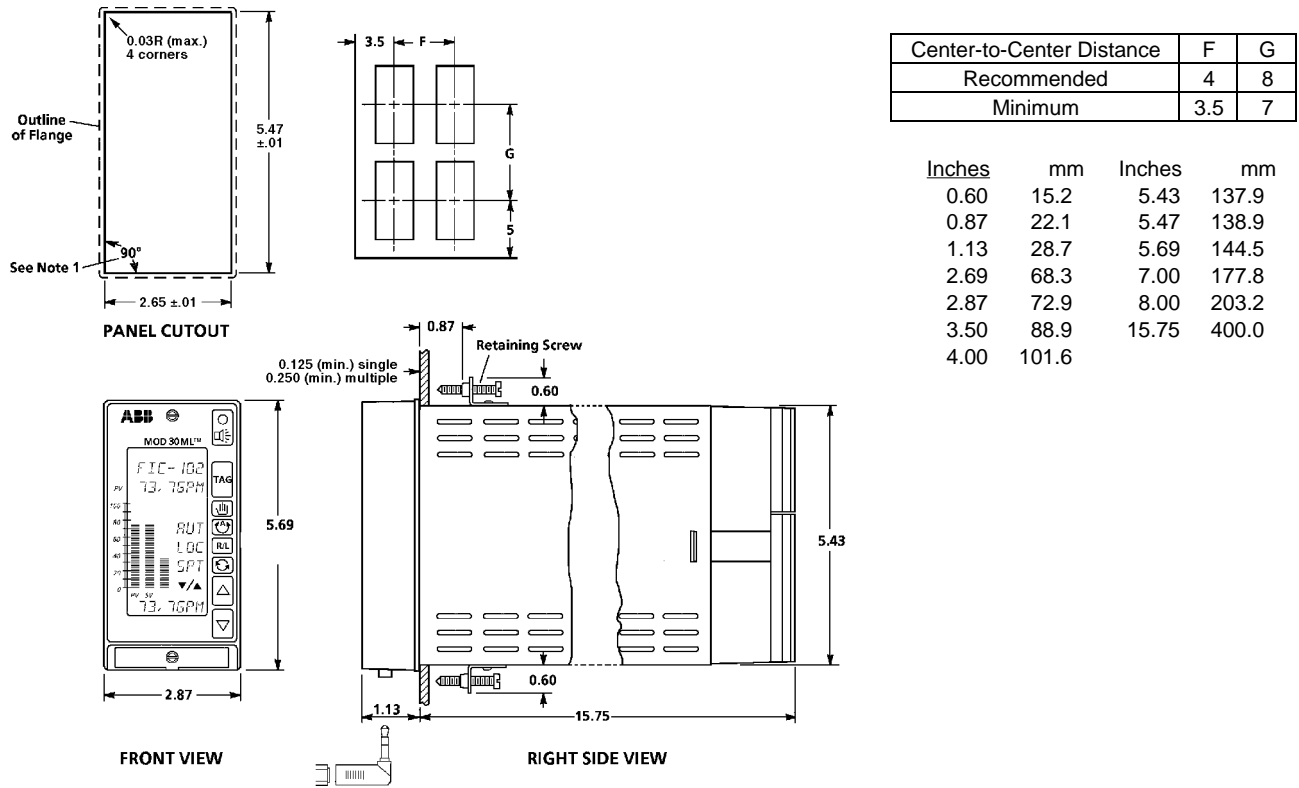

1.5 inch (38.1mm) clearance for optional communications jack.

- NOTES:
1. When mounting housing in panel cutout or rack and panel mounted bezel, turn retaining screws until point of screw touches rear of panel or bezel. Overtightening of retaining screws will distort housing. Housing must be square after retaining screws are tightened.
 2. Only the NEMA 4 option contains the gasket and lower front panel screw. Also, communication jack and service manual switch not present on NEMA 4 option.
 3. The 1801R has a bezel width of 2.735in (69.47mm) and uses the same panel cutout as the 1800R.

Figure 2-2 Controller Mounting Dimensions

MECHANICAL INSTALLATION

SECTION 3

POWER, GROUNDING, AND BUILT-IN I/O CONNECTIONS

3.1 GENERAL

Read this section thoroughly before making any connections. Installation personnel should be qualified technicians. Observe all electrical code requirements and safety standards applicable to these wiring procedures.

Specific instructions and connection diagrams for the various built-in inputs and outputs are provided in **Sections 3.3 through 3.7**. A listing of the applicable electrical specifications is included in each section.

3.2 CONNECTION GUIDELINES

The wiring connections described in this section are made with the controller installed in its operating location and with the power off. All connection terminals are located under a cover on the back of the instrument housing. Figure 3-1 shows the terminals with the cover removed.

! CAUTION *Do not connect any wires to terminals 23, 24, 48, and 49. Connections to these terminals can cause an instrument malfunction.*

The recommended procedure for making power, grounding, and built-in I/O connections is as follows:

1. Make a copy of the wiring planning sheet, **Appendix A**, and list each wire connection. It is recommended that the planning sheet be used to plan and document all wiring connections: power, grounding, built-in I/O, modular I/O, and communications. Connection instructions for modular I/O and communications are provided in **Sections 4 and 5**.
2. The power wire size must be from 14 AWG (1.6 mm) to 18 AWG (1.0 mm) with a 600V, -20°C +105°C UL, CSA approved rating.
3. The signal wire size can be as small as 22 AWG (0.65 mm). All analog input wiring must be shielded twisted pairs. Shields must be connected to a good noise free ground (the chassis ground terminal at the upper right hand corner of the housing is recommended). See **Section 3.4.4** for more information.
4. Route signal wiring less than 30 V rms, 42.4 V peak or 60 V dc from top left. Route signal wiring greater than 30 V rms, 42.4 V peak or 60 V dc from bottom right. Distribute to appropriate terminals.

POWER, GROUNDING, AND BUILT-IN I/O CONNECTIONS

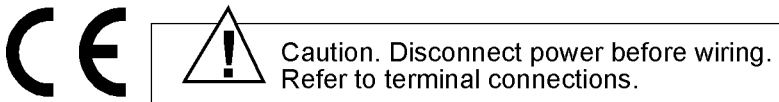
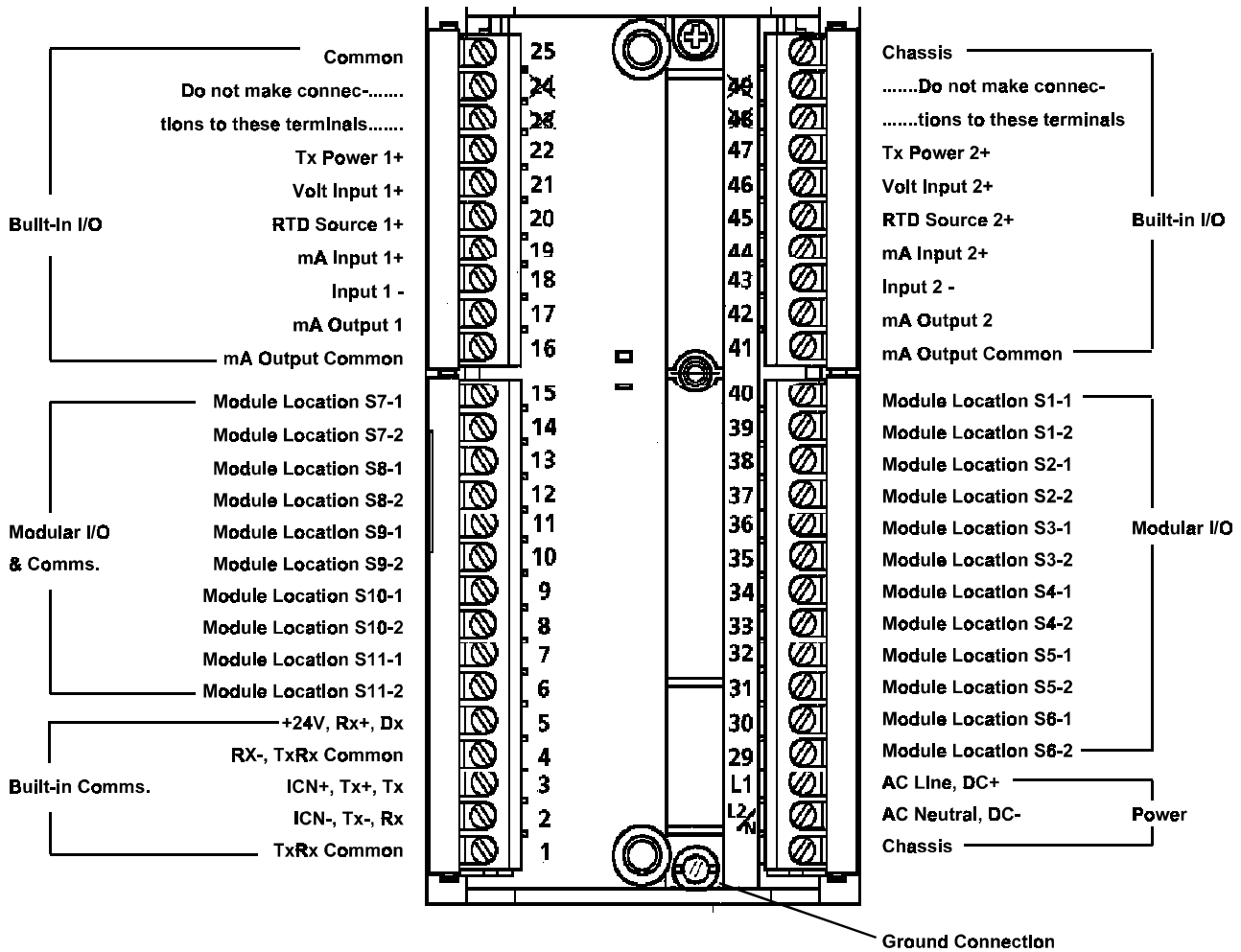

Figure 3-1. Electrical Connection Terminals

POWER, GROUNDING, AND BUILT-IN I/O CONNECTIONS

5. Use a small flat-head screwdriver to loosen appropriate connection screws and clamps on terminal blocks.
 6. Strip approximately 5/16 inch (8 mm) of insulation from the end of each wire, insert wires at assigned terminals and secure terminal screws and clamps.
 7. Make wiring connections using the following procedures:
 - a. Power connections - **Section 3.3**.
 - b. Ground and shield connections - **Section 3.4**.
 - c. Built-in process input connections for various types of inputs - **Section 3.5**
 - d. Built-in output connections - **Section 3.6**
 8. After all connections are completed and checked, do the following:
 - a. If modular I/O and communications are required, follow the procedures in **Sections 4 and 5**.
 - b. If all connections are completed, the ac power wiring can be connected at the distribution panel (ac source).
- * **NOTE:** Before putting the controller into operation, it must be configured using either the front panel keys or the 2006S Application Builder Software. See **Section 1.1.2** for related documents.

POWER, GROUNDING, AND BUILT-IN I/O CONNECTIONS

3.3 POWER CONNECTIONS

Δ WARNING *Avoid electrical shock. AC power wiring must **not** be connected at the **distribution panel** (ac source) until all wiring procedures are completed.*

All power wiring must be in compliance with the requirements of the National Electrical Code or Canadian Electrical Code. In any installation where the power source does not have one side of the line connected as a neutral conductor, both sides of the line must be overcurrent protected.

The controller does not contain a power disconnect switch. Install a disconnect switch or circuit breaker between the controller and its power source. Choose an accessible location as near to the controller as practical, and identify the switch or breaker as the disconnecting device for the controller.

The ac power connections are made to the power terminals shown in Figure 3-1 Route power cable from the bottom right hand side of the housing.

Power specifications for the controller are:

Power Supply Input:
Instrument Power Code 1: 85 to 250 V rms, 50 to 400 Hz
Instrument Power Code 0: 20 to 50 Vdc (———)
Power Consumption (120V rms, 60 Hz): 50 VA maximum
Transient Overvoltages: Classified as Installation (Overvoltage) Category II per IEC 664 (Specifies a maximum impulse withstand voltage of 1500 V for phase to earth voltage of 150 Vrms)
Interruption: No effect from 2 cycle dropout at 120V rms, 60 Hz.
Interference: No permanent effect from exposure to IEC 801-4 fast transients level 3, or IEC 801-5 surges level 3.

Internal Fuse:
DC Version: 4 amps, 250 V Slow Blow, soldered in
AC Version: 2.5 amps, 250 V Slow Blow, soldered in
External switch or circuit breaker rating:
DC Version: 3 amps, 28 VDC
AC Version: 1 amps, 250 VAC

POWER, GROUNDING, AND BUILT-IN I/O CONNECTIONS

3.4 GROUND CONNECTIONS

A protective ground terminal (green metal stud) is provided at the bottom of the terminal blocks near the power connections, Figure 3-1. Connect this terminal directly to the plant safety ground system. This terminal is to be used only for the protective ground conductor. Keep the ground wire as short as possible and use the largest practical wire gage.

3.4.1 Chassis and Shield Grounds

The green metal protective ground stud connects directly to the metal instrument chassis, and to the power input filter in the instrument power supply. The two terminals identified as chassis in Figure 3-1 are also internally connected to the protective ground stud. The chassis terminals can be used for shield connections.

3.4.2 Circuit Common Connections

The instrument circuit common is isolated from the protective ground. This makes it easier to avoid dc ground loops, and helps isolate the instrument from noise which may be present on the protective ground.

Instrument common is the negative return for both of the built-in analog output circuits. Common is available on terminals 16 and 41 for convenient connection of the outputs (see Figure 3-1 and **Section 3-7**).

Circuit common is also available at terminal 25 for connection to an instrument system ground. If the installation does not include an instrument system ground, then connect circuit common to one of the terminals identified as chassis in Figure 3-1. Never leave circuit common completely floating. Circuit common must always have some dc path to ground to prevent the possible build up of static charges, and to reduce noise pickup.

3.4.3 Electrical Noise

Electrical disturbances can be caused by lightning, motors and motor driven devices, relays, solenoids, and communication equipment. These disturbances often introduce electrical noise in power lines, transmission lines, and site grounds. The successful operation of any microprocessor-based device depends, in part, on the precautions taken to minimize the effect of these disturbances. Often called "transients" or "voltage spikes", this form of noise is infinitely variable in terms of amplitude, frequency, and duration.

Common sources of this type of noise are:

- loose or poor quality connections (especially power connections)
- arc welding equipment
- switches operating inductive loads
- relays, solenoids and other coil operated devices
- high current conductors – electric heater circuits
- fluorescent or neon lamps
- motors and motor driven devices
- switch mode devices – SCRs, thyristors
- lightning
- electrostatic discharges

POWER, GROUNDING, AND BUILT-IN I/O CONNECTIONS

3.4.4 Noise Prevention Measures

Primary power circuit distribution system:

- Ideally, each microprocessor-based device should be provided with an independent dedicated power source. Where this approach is not feasible due to space availability or cost per device, an acceptable alternative is to install constant voltage, isolation transformers in the branch circuit where the microprocessor-based device is installed.
- In addition to the above, install a combination transient surge suppressor and noise filter in the instrument side of the power distribution system. The combination device suppresses transients and effectively reduces other noise forms such as electromagnetic (EMI) and radio frequency (RFI) interferences. These devices can be connected to multiple units to reduce overall cost.

Input signals

- Twisted wire pairs are essential. The wire type should be stranded, not solid. The largest wire gauge allowed is best and the more twists per foot the better. A 2-inch lay (6 twists per foot) should be the minimum used.
- In addition to the above, signal wires should be physically isolated from all power conductors (separate conduit, cable race, etc.)
- Shielded wire is also essential. Shields must be terminated at the instrument or in the field in accordance with local regulations.

- ! CAUTION**
1. Never terminate a shield at both ends. One end must always be left "floating" or ground currents may be introduced.
 2. Thermocouple shields should be terminated at the process measurement end. Most thermocouples are constructed where the sensor is electrically equivalent to the process connection (grounded junction).

Equipment grounding:

- Grounding practices defined by the National Fire Protection Agency (NFPA) in their National Electrical Code (NEC) handbook or State agency amendments to this code should be strictly observed.
- Existing ground conductors and ground paths should be periodically inspected and tested to insure continuity and compliance with current code requirements.
- For best noise reduction performance, the microprocessor-based device's ground terminal should be connected to a nearby grounded large metal structure, using the shortest length wire possible. If a three-wire cordset is used to power the microprocessor-based device through a receptacle, the ground wire is generally too long and too noisy to be a good ground.

POWER, GROUNDING, AND BUILT-IN I/O CONNECTIONS

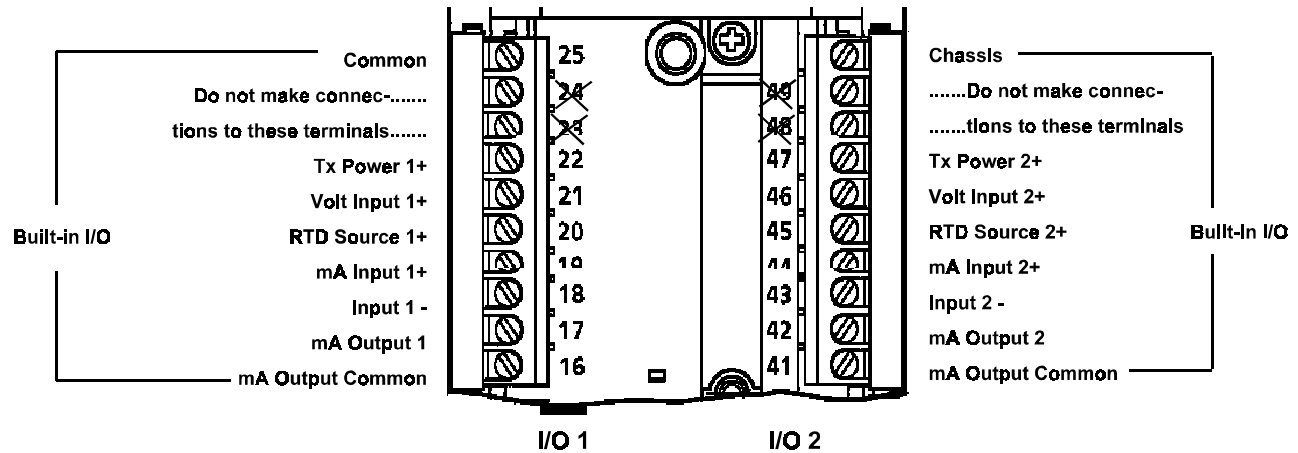

Caution. Disconnect power before wiring.
Refer to terminal connections.

Figure 3-2. Terminal Identifications for Built-in I/O

3.5 BUILT-IN PROCESS INPUT CONNECTIONS

Built-in inputs 1 and 2 are isolated universal analog inputs which accept volts dc, millivolts dc, milliamps dc (includes 2-wire transmitters), RTD, Thermocouple, and resistance signals. Connections to these inputs are made to the terminals shown in Figure 3-2. The input circuit diagrams in this section (Figures 3-3 to 3-9) identify Input 1 terminals as **I/O 1** and Input 2 terminals as **I/O 2**.

Each of the two built-in analog input circuits is isolated from every other circuit. It is recommended that either the Input– or the mA Input + terminal be connected to ground at some point in the system to prevent possible buildup of static electricity and reduce the pickup of noise.

The input circuit and input signal specifications for each input type are shown in the following sections:

- Volt, Millivolt and Thermocouple Input - **Section 3.5.1**
- RTD Input - **Section 3.5.2**
- Current Input from a 2-Wire Transmitter - **Section 3.5.3**
- Current Input from a Non 2-Wire Transmitter - **Section 3.5.4**
- Resistance Input - **Section 3.5.5**

General specifications for built-in process inputs are:

Input Isolation: Galvanic isolation using transformers and optical isolators. Input Common Mode Rating: 45V dc Common Mode Rejection: 120 dB @ 50/60 Hz Normal Mode Noise Filter: 20 dB minimum @ 60 Hz Maximum Normal Mode Voltage: 30V dc (except current input) Display Accuracy: Input accuracy \pm one least significant display digit
--

POWER, GROUNDING, AND BUILT-IN I/O CONNECTIONS

3.5.1 Built-In Voltage, Millivolt and Thermocouple Inputs

Make volt, millivolt and thermocouple input connections as shown in Figure 3.3. Always connect the first thermocouple input to the I/O 1 terminals to enable automatic cold junction compensation for all thermocouple inputs.

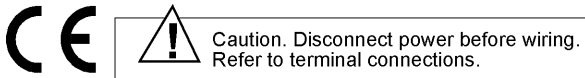
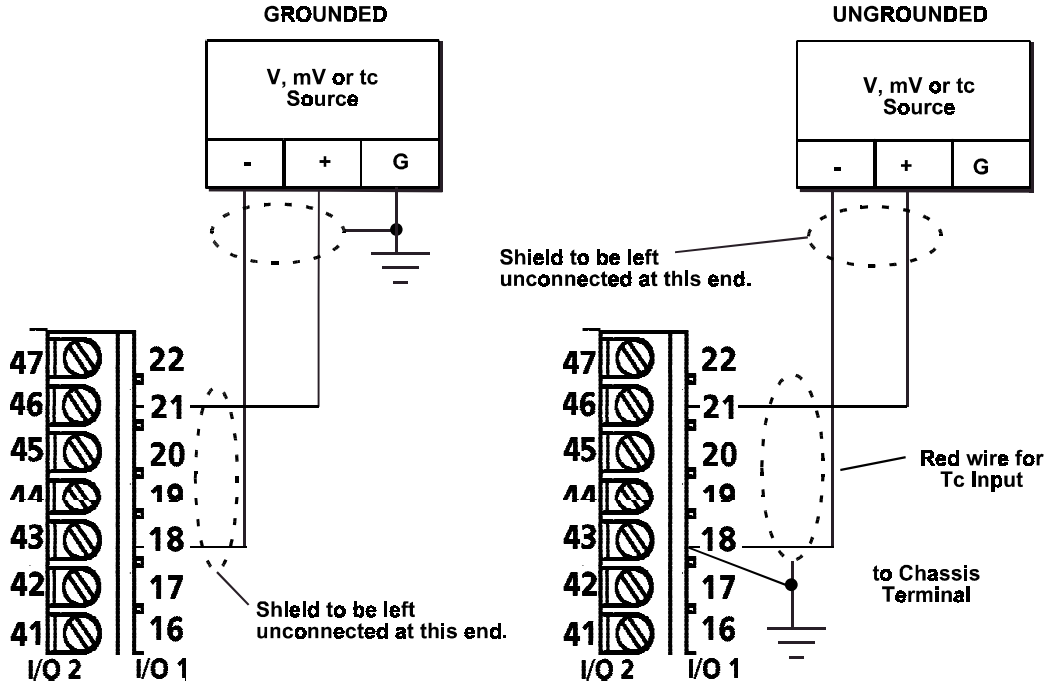

Figure 3-3. Built-in Voltage, Millivolt and Thermocouple Input Connections

Volt input specifications are:

Input Range: -10 mV to +6 Vdc
Input Impedance: 10M ohms minimum
Resolution: less than 50 microvolts
Accuracy: 0.05% of input or 100 microvolts, whichever is greater
Temperature Effect: 0.01% per °C or 10 microvolts per °C, whichever is greater
Burnout Detection: Reading goes downscale when any lead opens.

Millivolt and Thermocouple input specifications are:

Input Range: -10 to 120 mVdc
Temperature range limits for thermocouple inputs: See Table 4-1
Input Impedance: 10M ohms minimum
Resolution: less than 1 microvolt
Accuracy: 0.08% of input or 20 microvolts, whichever is greater
Temperature Effect: 0.01% per °C or 1 microvolt per °C, whichever is greater
Burnout Detection: Configurable for thermocouple inputs and millivolt signals which represent thermocouple inputs. Choices are upscale or downscale excursion of reading when any lead opens, or no detection.

POWER, GROUNDING, AND BUILT-IN I/O CONNECTIONS

3.5.2 Built-In RTD Input

Make RTD input connections as shown in Figure 3-4. See **Section 4.3.6** for a listing of materials, standards and sample RTDs supported by the instrument software.

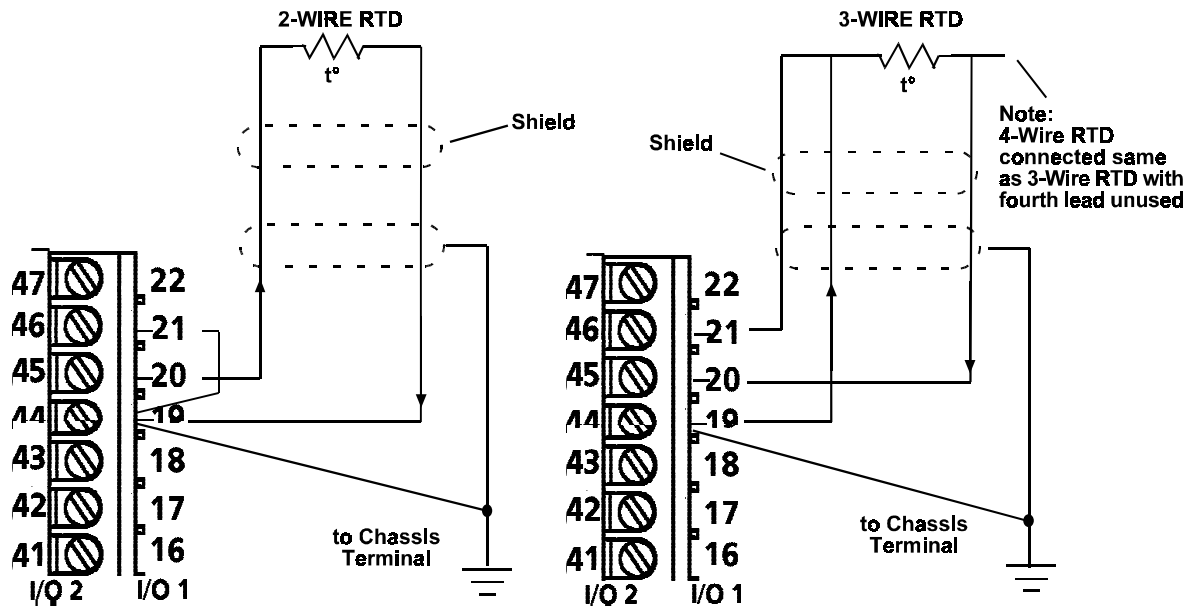

Caution. Disconnect power before wiring.
Refer to terminal connections.

Figure 3-4. Built-in RTD Input Connections

RTD input specifications are:

RTD Type: 3-Wire or 2-Wire

Range: Configurable

- Normal Range: 0 to 430 ohms
- Low Range: 0 to 55 ohms

Resolution: less than 0.004 ohms

Accuracy: $\pm 0.05\%$ of input resistance or 0.1 ohms whichever is greater

Temperature Effect: $\pm 0.01\%$ per $^{\circ}\text{C}$ or 0.01 ohms per $^{\circ}\text{C}$ whichever is greater

RTD Current: 250 microamps typical

Burnout Detection: Reading goes upscale when any lead opens

POWER, GROUNDING, AND BUILT-IN I/O CONNECTIONS

3.5.3 Built-In Current Input - 2-Wire Transmitter

Make input connections from a 2-wire transmitter as shown in Figure 3-5.

22mA Maximum Loop Current

When the maximum required loop current is 22 mA or less, make connections as shown in the left hand view of Figure 3-5. In this connection arrangement, the 2-wire loop receives its current from a 24V supply in the controller. The current supply is automatically connected in the circuit when the 2-wire input connection is made.

50 mA Maximum Loop Current

If the maximum required loop current is 50 mA, make connections as shown in the right hand view of Figure 3-5. In this connection arrangement, an external power supply must be used to meet the 50 mA requirement.

Current input and transmitter power supply specifications are:

Input Range: 0 to 20 mA dc, Limited to below 70 mA
Input Impedance: 50 ohms nominal
Resolution: less than 1 microamp
Accuracy: $\pm 0.1\%$ of input or 2 microamps, whichever is greater
Temperature Effect: 0.01% per °C or 0.2 microamps per °C, whichever is greater
Transmitter Power Supply: Isolated 24V dc, 20 mA transmitter power supply is built into controller. For current inputs above 20 mA, a separate external power supply must be used.

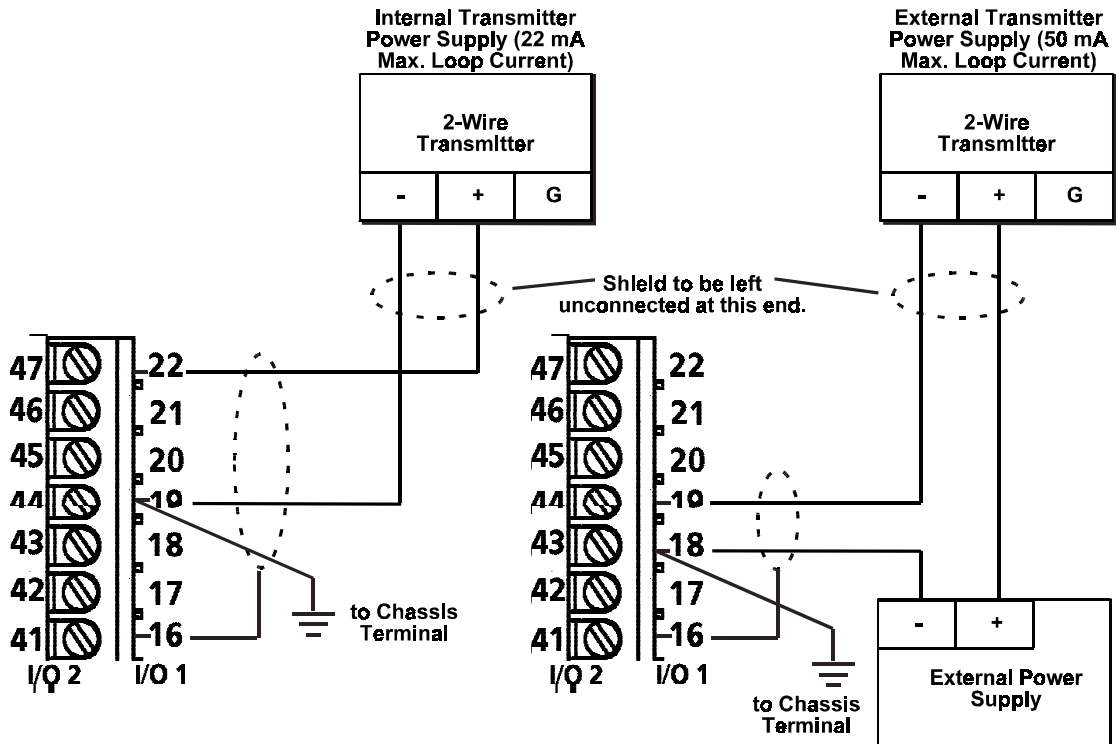

CE  Caution. Disconnect power before wiring. Refer to terminal connections.

Figure 3-5. Built-in 2-Wire Milliampere Current Input Connections

POWER, GROUNDING, AND BUILT-IN I/O CONNECTIONS

3.5.4 Built-In Current Input - Non 2-Wire Transmitter

Make current input connections from a non 2-wire transmitter as shown in Figure 3-6. Note that the transmitter must be powered from an external source which meets the transmitter power specifications.

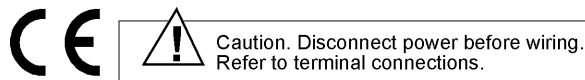
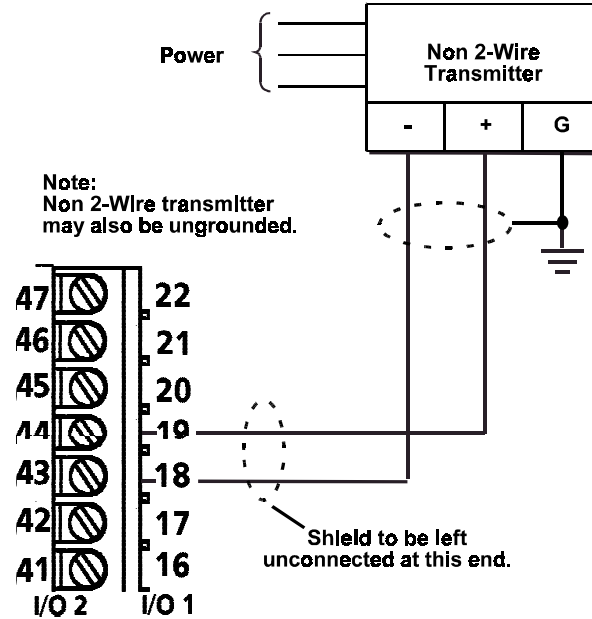

Figure 3-6. Built-in Non 2-Wire Current Input Connections

Current input specifications are:

Input Range: 0 to 54 mA dc, Limited to below 70 mA
Input Impedance: 50 ohms nominal
Resolution: less than 1 microamp
Accuracy: $\pm 0.1\%$ of input or 2 microamps, whichever is greater
Temperature Effect: 0.01% per $^{\circ}\text{C}$ or 0.2 microamps per $^{\circ}\text{C}$, whichever is greater

POWER, GROUNDING, AND BUILT-IN I/O CONNECTIONS

3.5.5 Built-In Resistance Input

The resistance input can be used to monitor a resistance which changes in proportion to a process related value such as a set-point. Make resistance input connections as shown in Figure 3-7.

The resistance input can also be used for a 2-wire RTD which is not on the list of supported RTDs in **Section 4.3.6**. Make the 2-wire RTD connections as shown in Figure 3-4. When using an RTD not supported by the instrument software, the data base must be configured to provide a user defined linearization using the Application Builder Software. Refer to **Section 1.1.2 Related Documents**.

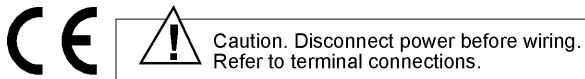
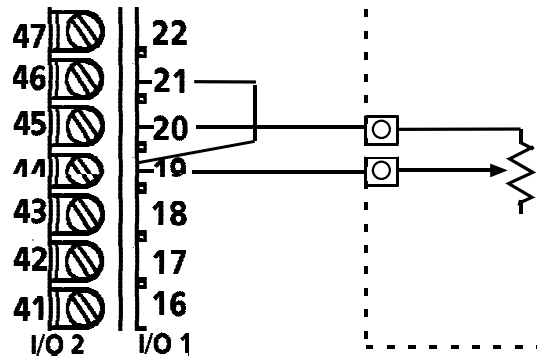

Figure 3-7. Built-In Resistance Input Connections

Resistance input specifications are:

- Range: Configurable
 - Normal Range: 0 to 430 ohms
 - Low Range: 0 to 55 ohms
- Resolution: less than 0.004 ohms
- Accuracy: $\pm 0.05\%$ of input resistance or 0.1 ohms whichever is greater

POWER, GROUNDING, AND BUILT-IN I/O CONNECTIONS

3.6 BUILT-IN OUTPUT CONNECTIONS

Built-in outputs 1 and 2 are milliamp analog control outputs. Connections to these outputs are made as shown in Figure 3-2. The output circuit diagrams, Figures 3-8 and 3-9 identify the Output 1 terminals as **I/O 1** and the Output 2 terminals as **I/O 2**.

The built-in outputs are always milliamp signals. When an application requires a voltage signal, a precision dropping resistor must be connected across the output terminals to generate the required voltage as shown in Figure 3-9.

Specifications for built-in outputs 1 and 2 are:

Range: 0 to 20 mA maximum, non-isolated
Resolution: 14 microamps
Accuracy: $\pm 0.2\%$ of setting or 14 microamps, whichever is greater
Temperature Effect: 0.01% per °C or 1 microamp per °C, whichever is greater
Load Resistance: 1000 ohms maximum at 22 mA
at 54 mA: 400 ohms maximum
Open Circuit Voltage: 25.5 volts typical
Ripple: 20 millivolts peak to peak at 100K Hz typical

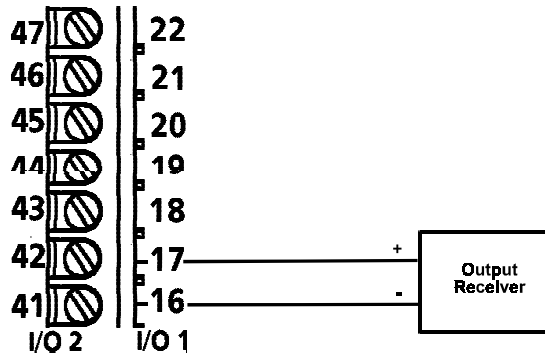

CE Caution. Disconnect power before wiring. Refer to terminal connections.

Figure 3-8. Built-in Milliampere Output Connections

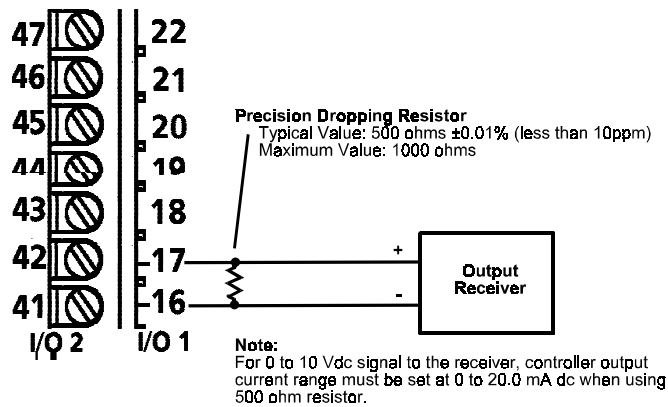

CE Caution. Disconnect power before wiring. Refer to terminal connections.

Figure 3-9. Built-in Voltage Output Connections

POWER, GROUNDING, AND BUILT-IN I/O CONNECTIONS

4

MODULAR I/O CONNECTIONS

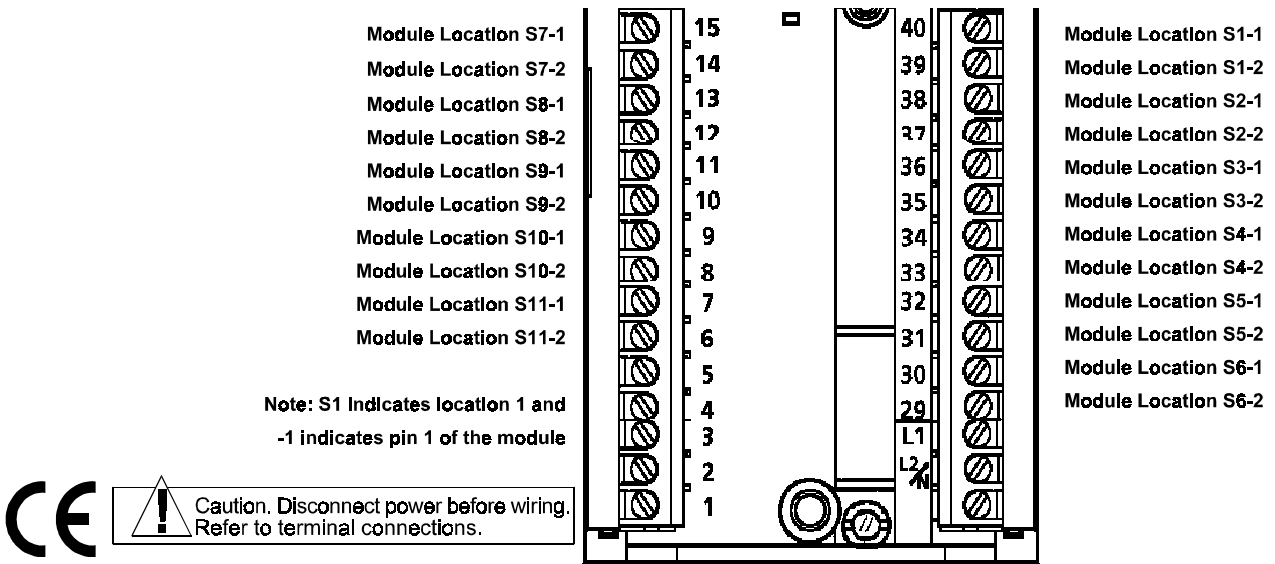

Figure 4-1. Terminal Identifications for Modular I/O

4.1 GENERAL

Read this section thoroughly before making any connections to modules. Installation personnel should be qualified technicians. Observe all electrical code requirements and safety standards applicable to these wiring procedures.

Specific instructions and connection diagrams for the various input and output modules are provided in **Sections 4.3 and 4.4**. A listing of the applicable electrical specifications is included with each diagram.

4.2 MODULAR I/O CONNECTION GUIDELINES

The wiring connections described in this section are made with the controller installed in its operating location and with the power off. All connection terminals are located under a cover on the back of the instrument housing. Figure 4-1 shows the modular connection terminals with the cover removed.

The recommended procedure for making connections to I/O modules is as follows:

1. The diagrams for single width modules show connections to a sample location (usually location 1). The terminal numbers for the actual location being used must be determined by matching pin numbers 1 and 2 in each diagram to the terminal numbers for the selected location as shown in Figure 4-1.
2. The spacing of module locations on the carrier board divides locations 1 through 10 into pairs allowing double wide modules to occupy only five different locations. The terminal numbers applicable to each dual location are shown on the connection diagrams for double wide modules.

MODULAR I/O CONNECTIONS

3. Route low-level signal wiring from the top left hand side of the housing and ac voltage wiring from the bottom right hand side and distribute to appropriate terminals.
4. Use a small, flat-head screwdriver to loosen appropriate connection screws and clamps on terminal blocks.
5. Strip approximately 5/16 inch (8 mm) of insulation from the end of each wire, insert wires at assigned terminals, and secure terminal screws and clamps.

<p>Δ WARNING All wiring connected to the controller terminals must be rated for the maximum voltage present, or alternately, wiring in circuits operating at greater than 30 volts must be rated for at least twice the circuit voltage.</p>

7. After all connections are completed and checked, do the following:
 - a. If communications are required, follow the applicable procedure in **Section 5**.
 - b. If all connections are completed, the ac power wiring can be connected at the distribution panel (ac source).

* **NOTE:** Before putting the controller into operation, it must be configured using either the front panel keys or the 2006S Application Builder Software. See **Section 1.1.2** for related documents.

4.3 MODULAR PROCESS INPUT CONNECTIONS

This section describes the process input connections for the following input module types:

- **2013A** Thermocouple Input Module with upscale burnout detection - **Section 4.3.1**
- **2004A** Solid-State Relay Input Module - **Section 4.3.2**
- **2006A** Nonisolated Digital Input Module - **Section 4.3.3**
- **2002A** Current Input Module - **Section 4.3.4**
- **2012A** Current Input Module with Two-Wire Transmitter - **Section 4.3.4**
- **2001A** Voltage Input Module - **Section 4.3.5**
- **2009A** RTD Input Module - **Section 4.3.6**
- **2020N** Remote I/O Interface Module - **Section 4.3.7**

4.3.1 2013A Thermocouple Input (TIM) and Cold Junction Compensation

Make thermocouple sensor connections as shown in Figure 4-2. The controller has automatic cold junction compensation which must be enabled by connection of a thermocouple to built-in input 1. When enabled, the automatic cold junction compensation provides compensation for both built-in and modular inputs, and use of a cold junction compensation module is not required. For any application requiring one or more thermocouple inputs, it is recommended that the first thermocouple be connected to built-in input 1 so that a cold junction module is not required.

In the event that a thermocouple cannot be connected to input 1, installation of a 2-wire RTD module with a CJC sensor is required for cold junction compensation. This module senses the temperature at the terminal block and provides cold junction compensation for all thermocouples connected to the controller.

The RTD sensor used for cold junction compensation is a platinum 1000 ohm RTD with an alpha of 0.00385. The sensor is Class B (0.12%) and has an operating temperature range of -50°C to $+650^{\circ}\text{C}$ (-58°F to $+1202^{\circ}\text{F}$). It is connected to a 2 wire RTD input module and installed in the housing.

Thermocouple input specifications are:

THERMOCOUPLE INPUT (with upscale burnout detection)

Types: B,E,J,K,N,R,S,T

Range: ± 100 mV DC (See Table 4-1 for temperature range limits)

Low limit: - 110 mV

Upper limit: + 110 mV

Input Resistance: 10 Megohms

Noise filter: 3 db at 3 Hz

Resolution: 16 bits

Sensitivity: 4 μV

Accuracy (calibrated): $\pm 0.1\%$ of span

Isolation : 250 Vrms

Max Survivable Input: ± 300 VDC or 250 VAC (Differential)

Common mode rejection: 100 db at 60 Hz typical

Normal mode rejection: 40 db at 60 Hz typical

RTD MODULE for COLD JUNCTION COMPENSATION (not required when automatic compensation is enabled)

Operating range: 0 to 50°C

Overrange: -20 to 70°C

Noise filter: 3 db at 4 Hz

Resolution: 16 bits

Sensitivity: 0.002°C

Accuracy: $\pm 0.5^{\circ}\text{C}$

Isolation : 250 Vrms

MODULAR I/O CONNECTIONS

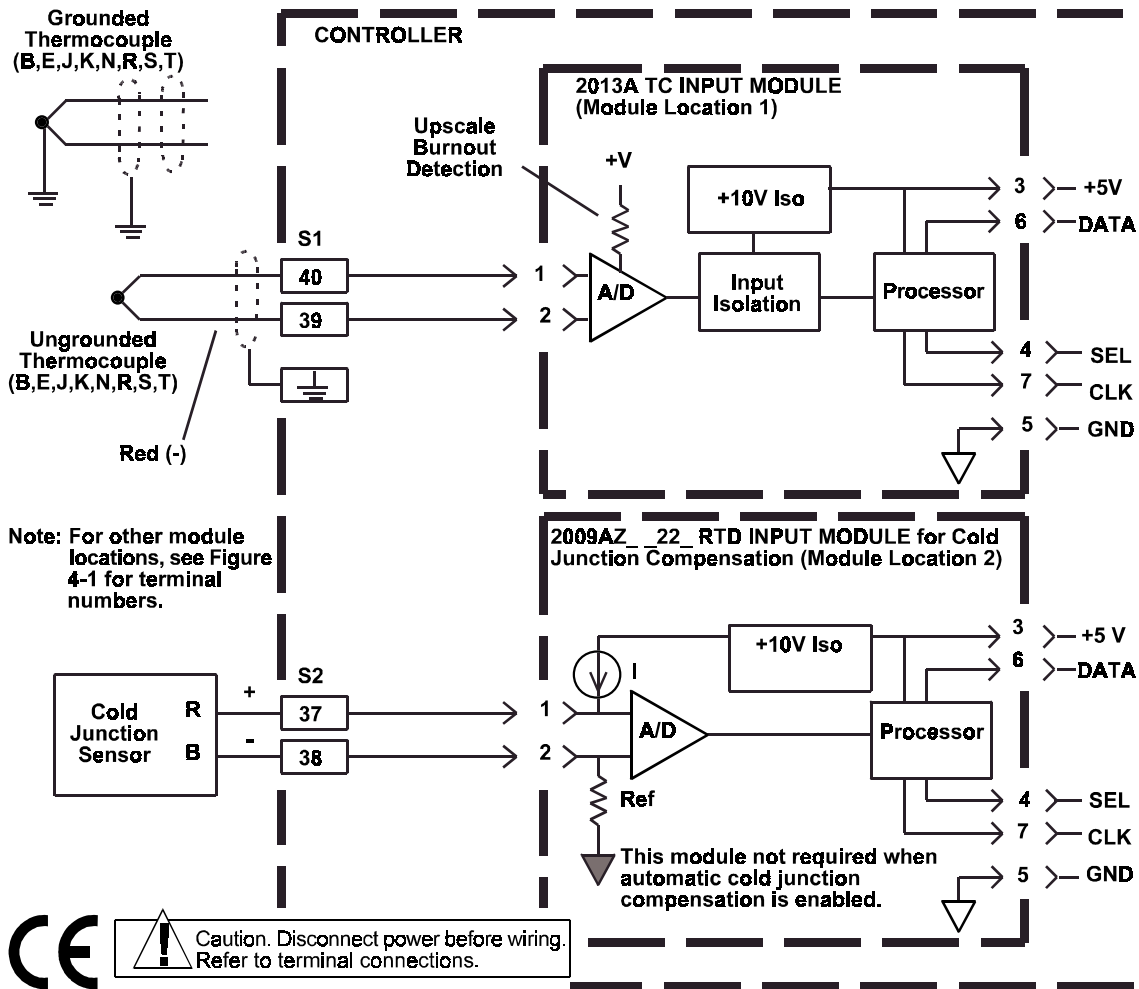

Figure 4-2. Typical Connections for a 2013A Thermocouple Input Module, and a 2009A RTD Module for Cold Junction Compensation

Table 4-1. Temperature Range Limits for Thermocouple Input Modules

Thermocouple	Measuring Range Limits			
	°C Lower	°C Upper	°F Lower	°F Upper
Type B	200	1820	392	3308
Type E	-200	1000	-328	1832
Type J	-210	760	-346	1400
Type K	-200	1372	-328	2501
Type N	0	1300	32	2372
Types R and S	0	1768	32	3214
Type T	-257	400	-430	752

4.3.2 2004A SSR Input (DIM)

Make Solid-State Relay (SSR) connections as shown in Figure 4-3. These input modules are used for sensing ON/OFF voltage levels. Each module provides optical isolation between the field devices and the control logic. This isolation is limited to 250 Vrms at the terminal block. Typical uses and applications for these input modules include sensing voltage and contact conditions from: proximity switches, limit switches, selector switches, push buttons, photoelectric switches, TTL compatible devices, float switches, or thermostats.

Wire rating: 600 V, -20°C +105°C UL, CSA approved

Δ WARNING All wiring connected to the controller terminals must be rated for the maximum voltage present, or alternately, wiring in circuits operating at greater than 30 volts must be rated for at least twice the circuit voltage.

Input specifications are:

DIGITAL INPUTS (ISOLATED)	_10_	_11_	_12_
Input voltage ranges	2.5-28Vdc	4-16Vdc	10-32Vdc, 12-32Vac
mA Input current at Max Line	30	45	25
Max Logic Low Input	1V, 0.2 mA	1V, 0.7 mA	3V, 1 mA
Input Resistance (Ohms)	900	300	1K (dc), 1.5K (ac)
Module Response Time (msec)	1.5	0.1	5
DIGITAL INPUTS (ISOLATED)	_13_	_14_	_15_
Input voltage ranges	35-60Vac/dc	90-140Vac/dc	180-280Vac/dc
mA Input current at Max Line	6 (dc), 25 (ac)	11	7
Max Logic Low Input	9V, 0.8 mA	45V, 3 mA	80V, 1.7 mA
Input Resistance	10K Ohms	14K Ohms	43K Ohms
Module Response Time (msec)	10 (dc), 15 (ac)	20	20

MODULAR I/O CONNECTIONS

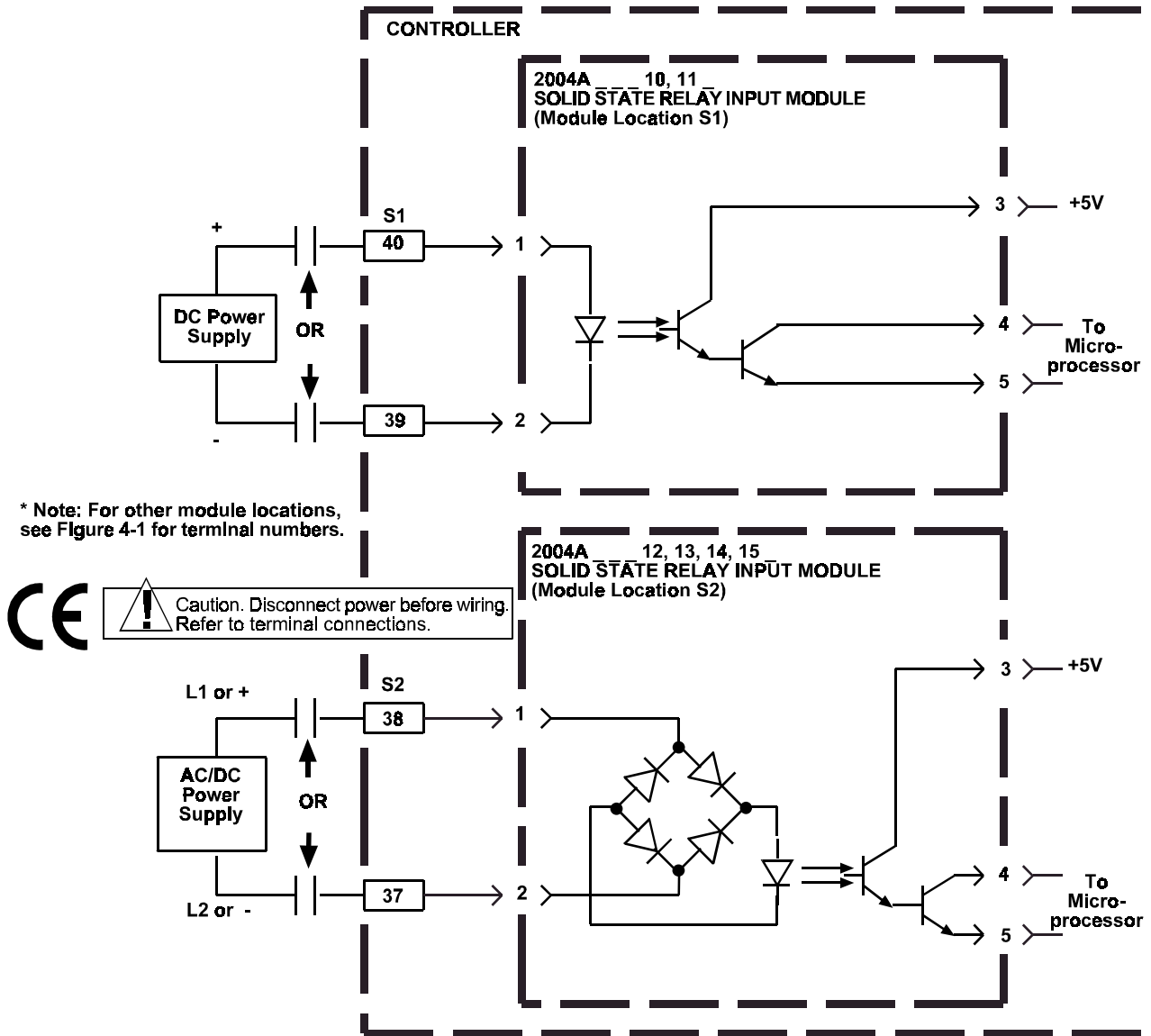

Figure 4-3. Typical Connections for a 2004A Solid State Relay Input Module

4.3.3 2006A Nonisolated Digital Input (DIM)

Make nonisolated digital input connections as shown in Figure 4-4. Input specifications are:

DIGITAL INPUTS (NONISOLATED)	
Input range	ON 2.2 to 24 VDC or 50 Ω maximum OFF 0 to 0.65 VDC or 50K Ω minimum
Max Input current	2.5 mA DC
Max Output current	20 mA DC
Response time	1 msec

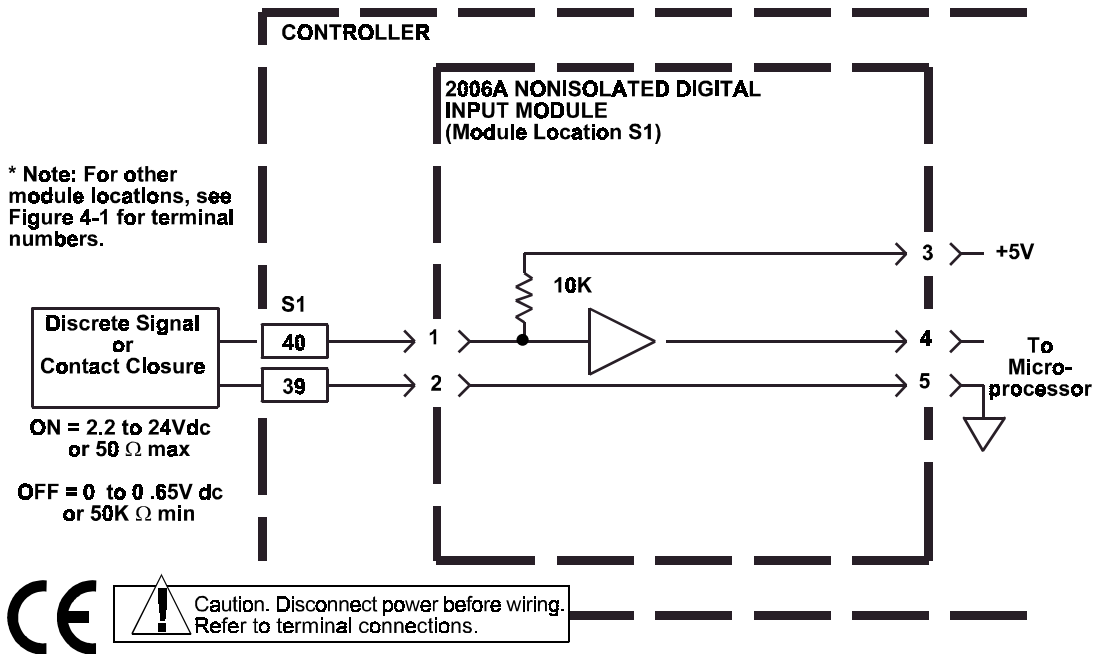

Figure 4-4. Typical Connections for a 2006A Nonisolated Digital Input Module

MODULAR I/O CONNECTIONS

4.3.4 2002A and 2012A Current Inputs (VCIM)

Make current input connections as shown in Figure 4-5 for 2-Wire Transmitter (2012A) and in Figure 4-6 for Non 2-Wire Transmitter (2002A).

2-Wire Transmitter (2012A)

The 2-wire version of the milliampere input receives its loop current from a 24V dc current supply built into the module. This current supply is automatically connected in the circuit when the 2-wire input connection is made. The load on the transmitter is nominally 100 ohms. Due to heat generated, this module must be installed in a location with no adjacent module on either side. Input specifications are:

ANALOG INPUT (CURRENT WITH 2-WIRE TRANSMITTER POWER)

- Range: (0-100%) 4 to 20mA
- Low limit: 0 mA
- Upper limit: 27.5 mA
- Input Resistance: 50 ohms
- Noise filter: 3 db at 5 Hz
- Resolution: 14 bits
- Sensitivity: 1 uA
- Accuracy (calibrated): $\pm 0.2\%$ of span
- Two Wire Excitation Supply
 - Open circuit voltage: 24V $\pm 5\%$
 - Short circuit current: maximum at 38 mA
- Isolation : 250 Vrms
- Max Survivable Input: ± 300 Vdc or 250 Vac (Differential)
- Common mode rejection: 100 db at 60 Hz minimum
- Normal mode rejection: 40 db at 60 Hz minimum

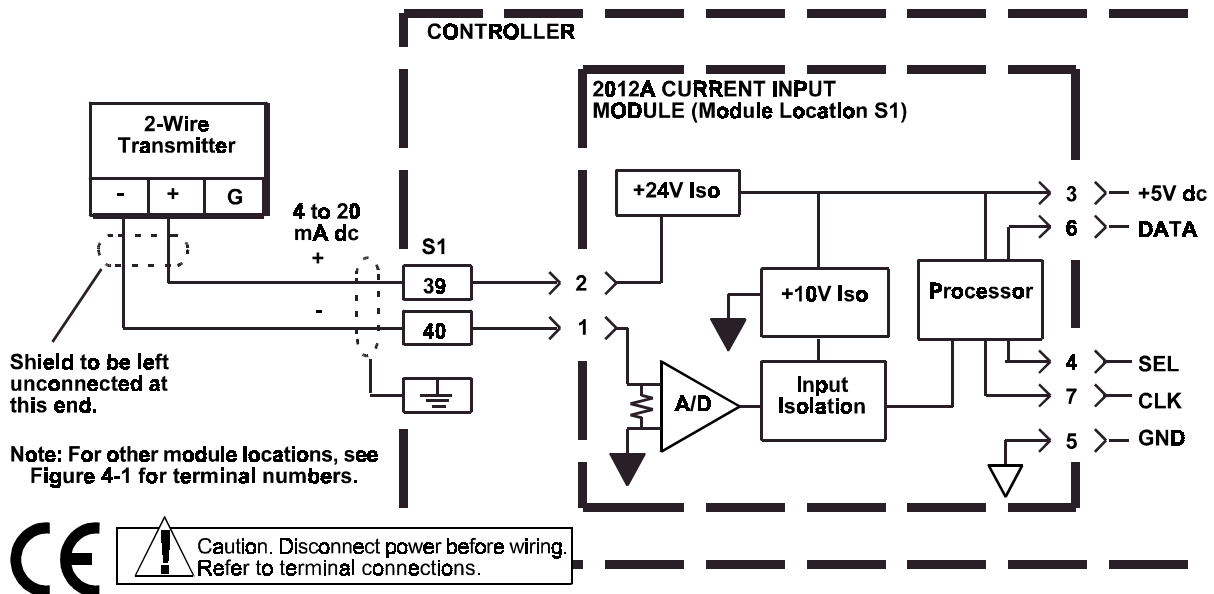

Figure 4-5. Typical Connections for a 2012A Current Input Module with 2-Wire Transmitter Power

Non 2-Wire Transmitter (2002A)

The non 2-wire transmitter version of the milliampere input receives its loop current from a supply in the transmitter. The transmitter load is nominally 100 ohms. The transmitter may be grounded or ungrounded. Input specifications are:

ANALOG INPUT (CURRENT)

Range: (0-100%) 4 to 20 mA

Low limit: 0 mA

Upper limit: 24 mA

Input Resistance: 250 ohm

Noise filter: 3 db at 5 Hz

Resolution: 13 bits

Sensitivity: 1.6 μ AAccuracy (calibrated): $\pm 0.2\%$ of span

Isolation : 250 Vrms

Max Survivable Input: 50 mA_{dc} (Differential)

Common mode rejection: 100 db at 60 Hz minimum

Normal mode rejection: 40 db at 60 Hz minimum

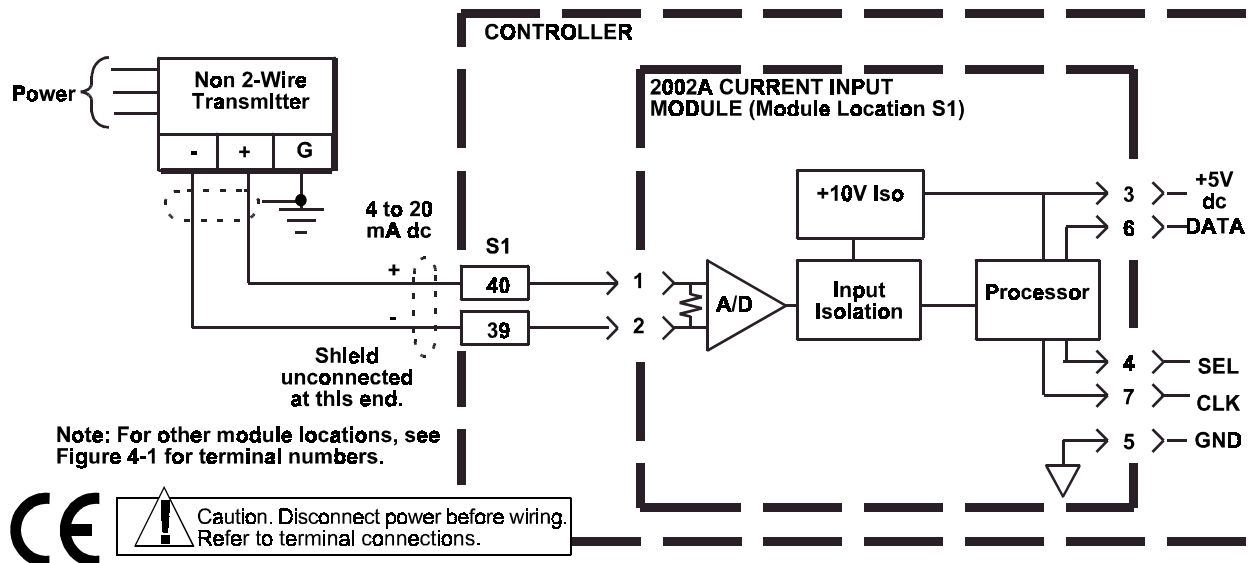

Figure 4-6. Typical Connections for a 2002A Current Input Module

MODULAR I/O CONNECTIONS

4.3.5 2001A Voltage Input (VCIM)

Make volt or millivolt connections as shown in Figure 4-7. Input specifications are:

ANALOG INPUT (VOLTAGE)
 Range: (0-100%) ± 10 Vdc, ± 100 mVdc
 Low limit: -11V, -110 mV
 Upper limit: +11V, +110 mV
 Input Resistance: 1 Megohm
 Noise filter: 3 db at 5 Hz, 3 db at 3 Hz
 Resolution: 16 bits
 Sensitivity: 0.4mV, 4 μ V
 Accuracy (calibrated): $\pm 0.1\%$ of span
 Isolation : 250 Vrms
 Max Survivable Input: ± 300 Vdc or 250 Vac (Differential)
 Common mode rejection: 100 db at 60 Hz minimum
 Normal mode rejection: 40 db at 60 Hz minimum

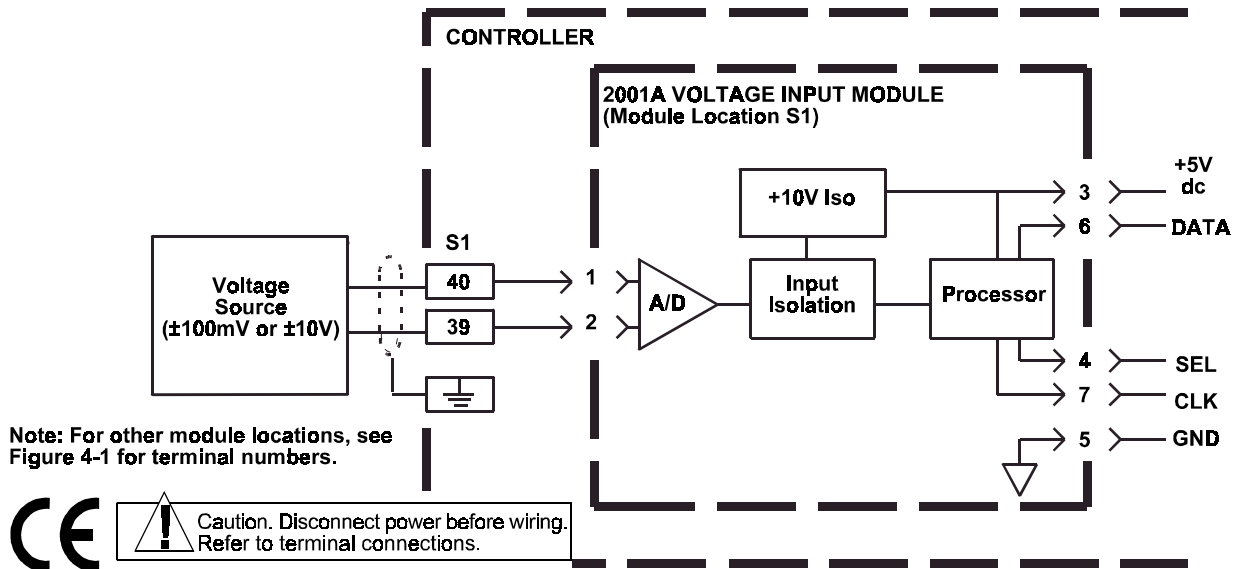

Figure 4-7, Typical Connections for a 2001A Voltage Input Module

4.3.6 2009A RTD Input (RIM, WRIM)

Make resistance input connections as shown in Figure 4-8. The 2 wire input module (RIM), uses a single wide case and the 3 wire input module (WRIM) uses a double wide case. Table 4-2 summarizes the RTD support standards and shows some sample RTDs.

Table 4-2. Supported RTD Materials and Standards and Sample RTDs

Sample RTDs and Appropriate Module			Supported RTD Materials and Standards		
Ω @ 0°C	Approx. Ω Range	RTD Module	Material	Alpha ($\Omega/\Omega/^\circ\text{C}$)	Standard
1000	184.94 to 3902.61	2 Wire	Platinum	0.003850	DIN 43760 (Note 1)
500	92.47 to 1951.31	2 Wire	Platinum	0.003850	DIN 43760 (Note 1)
1000	555.00 to 3169.25	2 Wire	Nickel	0.006720	Minco (Note 2)
100	18.49 to 390.26	3 Wire	Platinum	0.003850	DIN 43760 (Note 1)
98.129	16.66 to 311.87	3 Wire	Platinum	0.003923	SAMA RC21-4
100	17.07 to 332.62	3 Wire	Platinum	0.003902	Burns
100	17.26 to 403.70	3 Wire	Platinum	0.003911	Minco (Note 2)
120	66.60 to 380.31	3 Wire	Nickel	0.006720	Minco (Note 2)

1. Also meets IEC 751 and BS 1904 Standards.
2. Sometimes called U.S. Industrial Standard.

Input specifications for the 2 wire and the 3 wire input modules are:

<p>RTD INPUT</p> <p>Range (0 to 100%): 2 Wire: 0 to 4000 Ohms 3 Wire: 0 to 400 Ohms</p> <p>Low limit: 0 Ohms High limit: 2 Wire: 4200 Ohms 3 Wire: 400 Ohms</p> <p>Module Counts (0 to 100%): -25000 to 25000 (converted to 0 to 50000 in controller)</p> <p>Sensitivity (One Count) 2 Wire: 0.08 Ohms 3 Wire: 0.008 Ohms</p> <p>Accuracy, calibrated at 5V supply and 25°C: $\pm 0.05\%$ of Range (This equals an absolute accuracy of ± 25 counts or ± 2 ohms for the 2 wire input or ± 0.2 ohms for the 3 wire input or $\pm 0.519^\circ\text{C}$ for the Platinum DIN 43760 curve)</p> <p>Temperature Effect (0°C to 50°C): 0.1% of Range</p> <p>Noise filter: 3 db at 5 Hz</p> <p>Max Resistance Each Lead: 100 Ohms</p> <p>Excitation Current (maximum) 2 Wire: 0.25 mA 3 Wire: 0.6 mA</p> <p>Burnout Detection on all leads: Upscale</p> <p>Isolation: 250 Vrms</p> <p>Common mode rejection: 100 db at 60 Hz minimum</p> <p>Normal mode rejection: 40 db at 60 Hz minimum</p>

MODULAR I/O CONNECTIONS

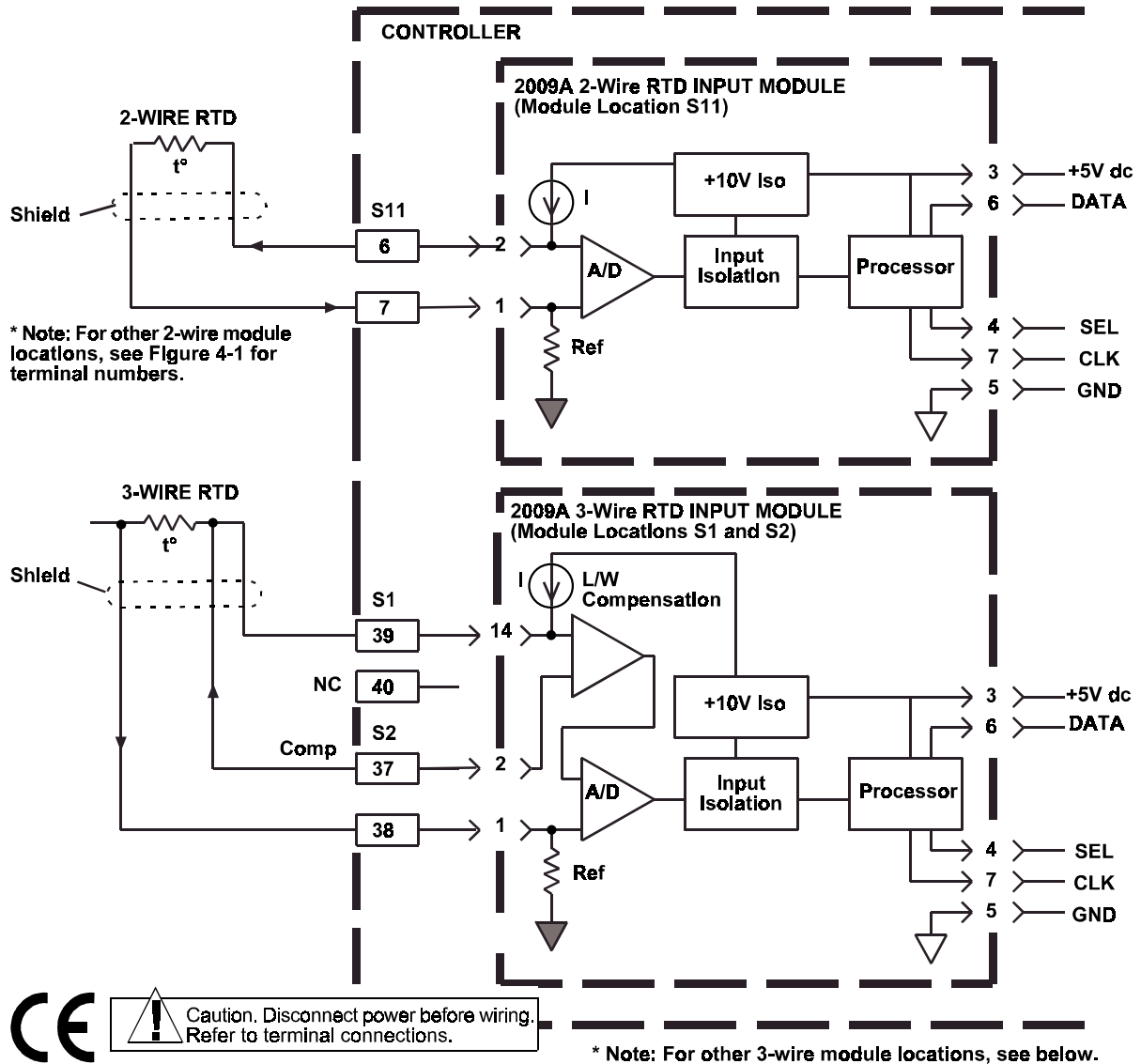

* Note: For other 3-wire module locations, see below.

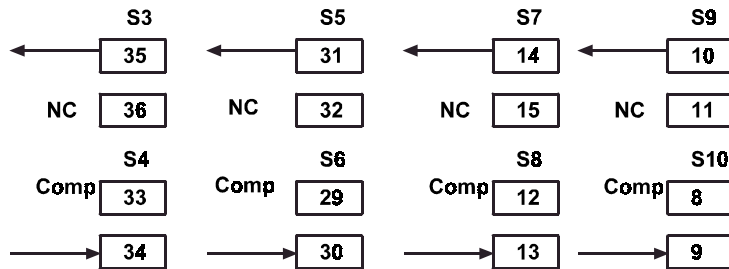

Figure 4-8. Typical Connections for a 2009A 2-Wire or 3-Wire RTD Input Module

* **NOTE:** The lead wire resistance effect is about +0.001 Ω/Ω (ohms per lead). Assuming 20 ohms per lead, the total error could be calculated as follows:

$$\text{Error} = ((0.001 \Omega/\Omega \times 20 \Omega/\text{lead}) \div 400\Omega \text{ Module Span}) \times 100\% = 0.005\%$$

4.3.7 2020N Remote I/O Interface Module (RIO)

Make remote I/O interface connections as shown in Figure 4-9. One remote I/O interface module is required for each remote I/O network. The remote I/O interface module is scanned every 50ms by the controller. Specifications are:

REMOTE I/O INTERFACE RS485 SERIAL NETWORK	
Bus Master	2020N Remote I/O Interface Module (end of bus)
Bus Slaves	Remote I/O Digital Modules
Maximum Length	500 meters (1600 feet)
Baud rate	187.5K
Max addresses	32 (31 slaves + 1 RIO master at address 0)
Termination	120 ohm resistor is required across the two conductors at the end of the cable (2 shipped with RIO module)
Shield	Required over 50 meters (160 feet)
REMOTE I/O INTERFACE CABLE	
Indoor use	Belden #9182
Indoor plenum use	Belden #89182
Underground use	Belden #9815 twisted twinax
Outdoors above ground use	NOT recommended
Wiring	Use same cable type throughout network. Avoid interruptions (wire to same terminals if necessary). Do not wire through terminal blocks.

Table 4-3. Supported Remote I/O Modules

	Module	Description
Digital Input Modules	ICSI 08 D1	8 non-isolated 24VDC input channels
	ICSI 08 E1	8 isolated 24VDC input channels
	ICSI 08 E3	8 isolated 120VAC input channels
	ICSI 16 D1	16 non-isolated 24VDC input channels
	ICSI 16 E1	16 isolated 24VDC input channels
Digital Output Modules	ICSO 08 R1	8 relay output channels 2A
	ICSO 08 Y1	8 transistor output channels 24VDC 2A
Digital Input/Output Modules	ICSK 20 F1	12 non-isolated 24VDC input channels and 8 isolated relay output channels
	ICSC 08 L1	8 user-configurable channels for 24VDC input or 24VDC 500mA transistor output

* **NOTE:** Modules are available in three forms: -120 for 110/120Vac external power, -230 for 220/230Vac external power and -24 for 24Vdc external power. All modules mount on a ECZ remote I/O module carrier. See **IB-23C601** for details on Remote I/O module installation and connection.

MODULAR I/O CONNECTIONS

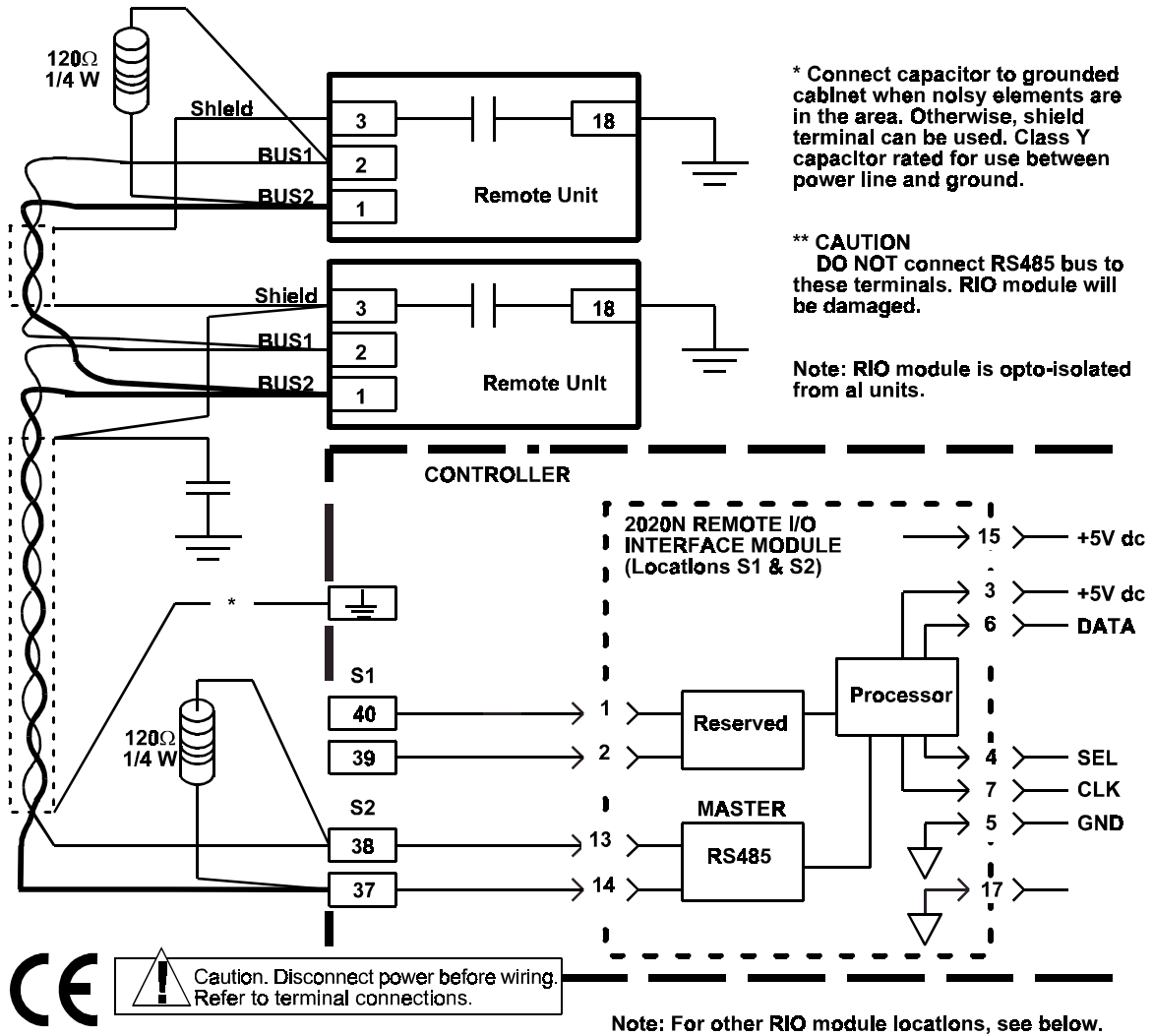

Note: For other RIO module locations, see below.

	S3	S5	S7	S9
**	36	**	32	**
	35		31	11
			15	10
	S4	S6	S8	S10
BUS1	34	BUS1	30	BUS1
BUS2	33	BUS2	29	BUS2
			13	9
			12	8

Figure 4-9. Typical Interface Circuit for 2020N Remote I/O Interface Module (RIO)

4.4 MODULAR OUTPUT CONNECTIONS

This section describes the process input connections for the following input module types:

- **2003A** Current Output Module - **Section 4.4.1**
- **2005A** Solid-State Relay Output Module - **Section 4.4.2**
- **2007A** Nonisolated Digital Output Module - **Section 4.4.3**
- **2011A** Dual Mechanical Relay Output Module - **Section 4.4.4**
- **2011A** Form C Mechanical Relay Output Module - **Section 4.4.5**

4.4.1 2003A Current Output (AOM)

Make current output connections as shown in Figure 4-10. Due to heat generated, this module must be installed in a location with no adjacent module on either side.

When the instrument is installed in the European Union, an interface filter must be connected in the signal wires to the module to comply with European Union (EU) Electromagnetic (EMC) requirements. Use a Phoenix Contact FILTRAB NEF1-1 or equivalent. Reference Phoenix Contact Ltd., P.O. Box 131, D32819, Blomberg, Lippe, Germany, Phone 52-35-320510.

Output specifications are:

ANALOG OUTPUT
 Range: (0-100%) 4 to 20 mA
 Low limit: 0 mA
 Upper limit: 25 mA
 Open circuit voltage: 26 Volts maximum
 load limit: 800 Ohms
 Isolation : 250 Vrms
 Resolution: 12 bits
 Sensitivity: 5 uA
 Accuracy: $\pm 0.2\%$ of span

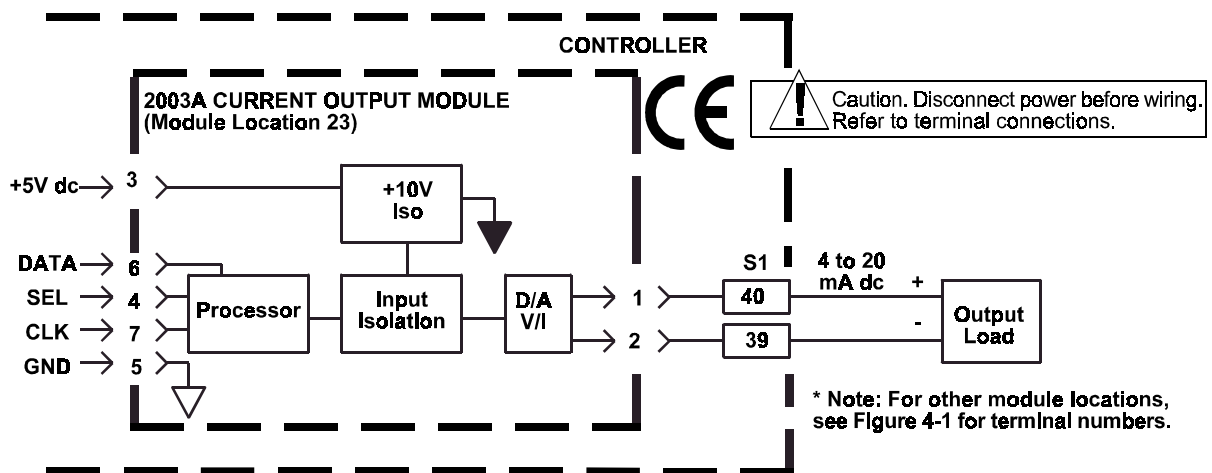

Figure 4-10. Typical Connections for a 2003A Current Output Module

MODULAR I/O CONNECTIONS

4.4.2 2005A SSR Output (DOM)

Recommended connections to a customer relay are shown in Figure 4-11. Make SSR output connections as shown in Figure 4-12.

DC output modules are used for controlling or switching DC loads. Each module provides optical isolation between the field devices and the control logic. This isolation is limited to 250 Vrms at the terminal block. Typical uses and applications for DC output modules include switching the following loads: DC relays, DC Solenoids, DC motor starters, or DC lamps or indicators. Wire rating: 600 V, -20°C +105°C UL, CSA approved. Module Fuse rating: 4 Amps, 250V.

DC DIGITAL OUTPUTS (ISOLATED)	<u>10</u>	<u>11</u>
Output voltage ranges	5-60 V	5-200 V
Max Output current	1A	0.55A
Turn-off time	0.75 msec	0.75 msec
Max Output voltage drop	1.6 V	1.6 V
Off-state leakage at max V	1 mA	2 mA

AC output modules are used for controlling or switching AC loads. Each module provides optical isolation between the field devices and the control logic. This isolation is limited to 250 Vrms at the terminal block. Typical uses and applications for AC output modules include switching the following loads: relays, solenoids and contactors, motor starters, heaters, lamps, or indicators. Wire rating: 600 V, -20°C +105°C UL, CSA approved. Module Fuse rating: 4 Amps, 250V.

AC DIGITAL OUTPUTS (ISOLATED)	<u>12</u>	<u>13</u>	<u>14</u>
Output voltage range	12-140 V	24-280 V	24-280 V
Max Output current	1A	1A	1A
Off-state leakage (2.5 at 120V)	5 mA	5 mA	5 mA
Minimum load current	20 mA	20 mA	20 mA
Response time	1/2 cycle	1/2 cycle	1/2 cycle
Max Output voltage drop	1.6 V	1.6 V	1.6V
Form A (Make)	A (Make)	B (Break)	
Type SPST-NO	SPST-NO	SPST-NC	

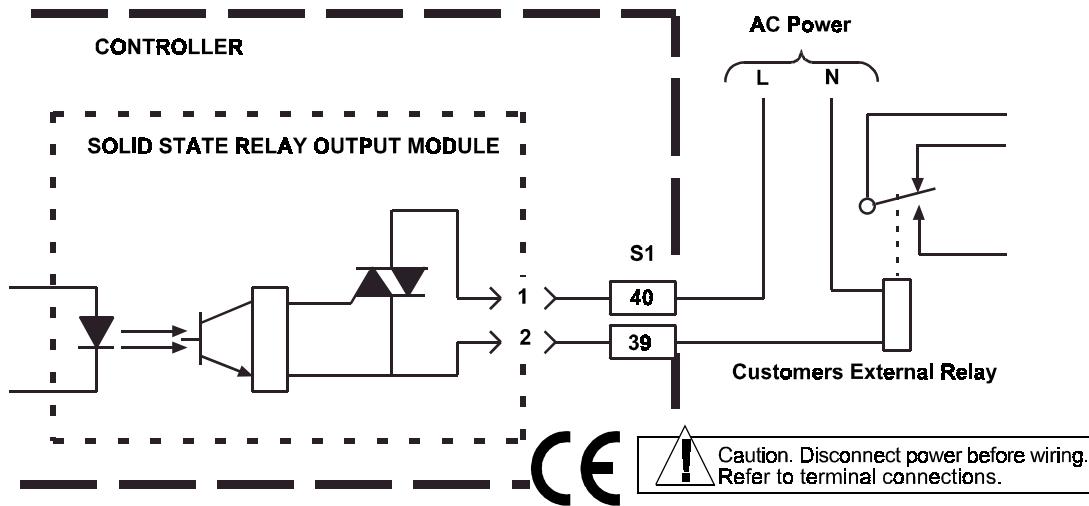

Figure 4-11. Recommended Connection to Solid State Relay

MODULAR I/O CONNECTIONS

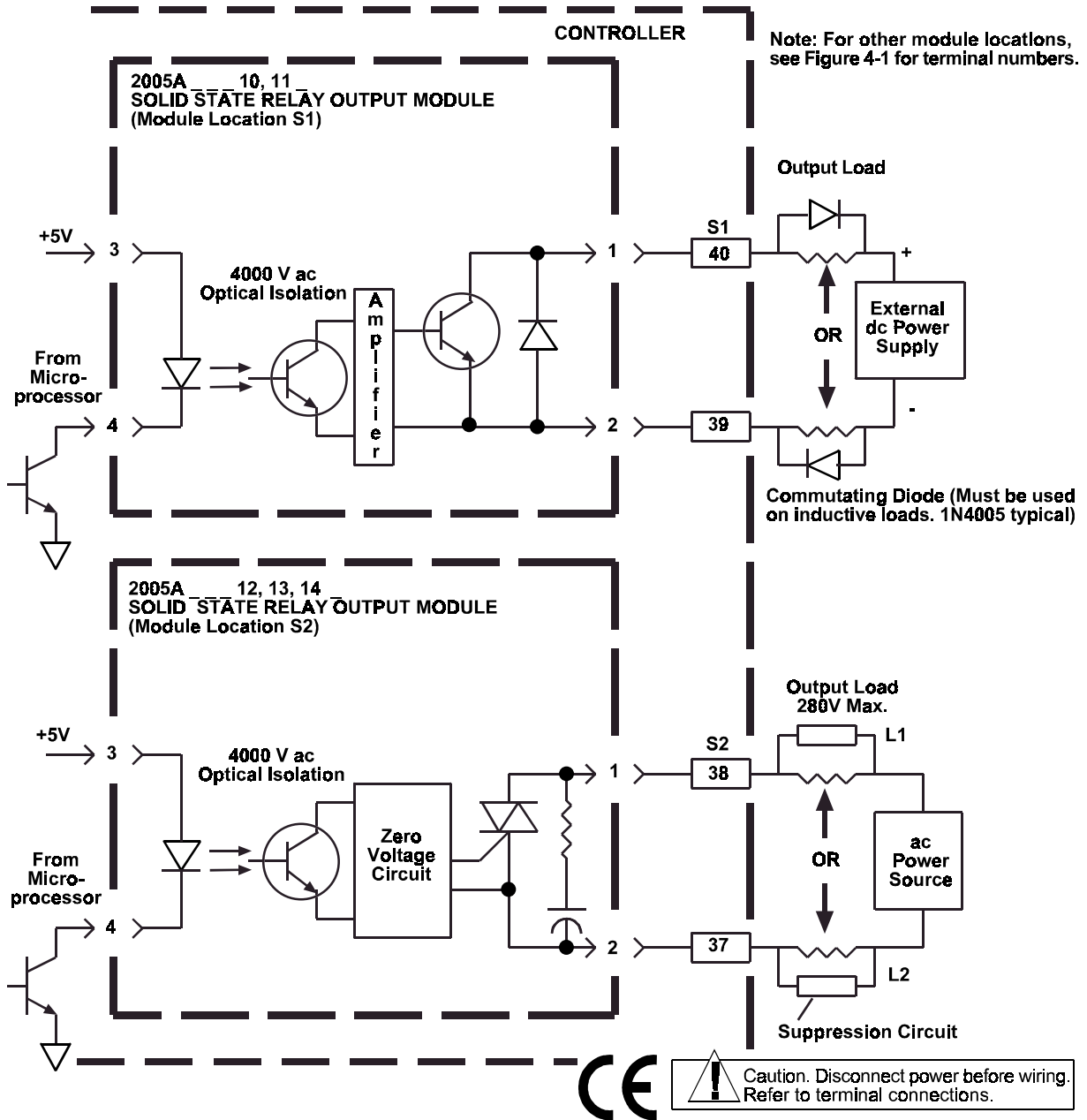

Figure 4-12. Typical Connections for a 2005A Solid State Relay Output Module

MODULAR I/O CONNECTIONS

4.4.3 2007A Nonisolated Digital Output (DOM)

Make nonisolated digital output connections as shown in Figure 4-13. Output specifications are:

DIGITAL OUTPUTS (NONISOLATED)	
Output voltage range	+5 to +24 Vdc
Max Output current	100 mAdc
Response time	100 usec
Mmaximum leakage current	100 uAdc

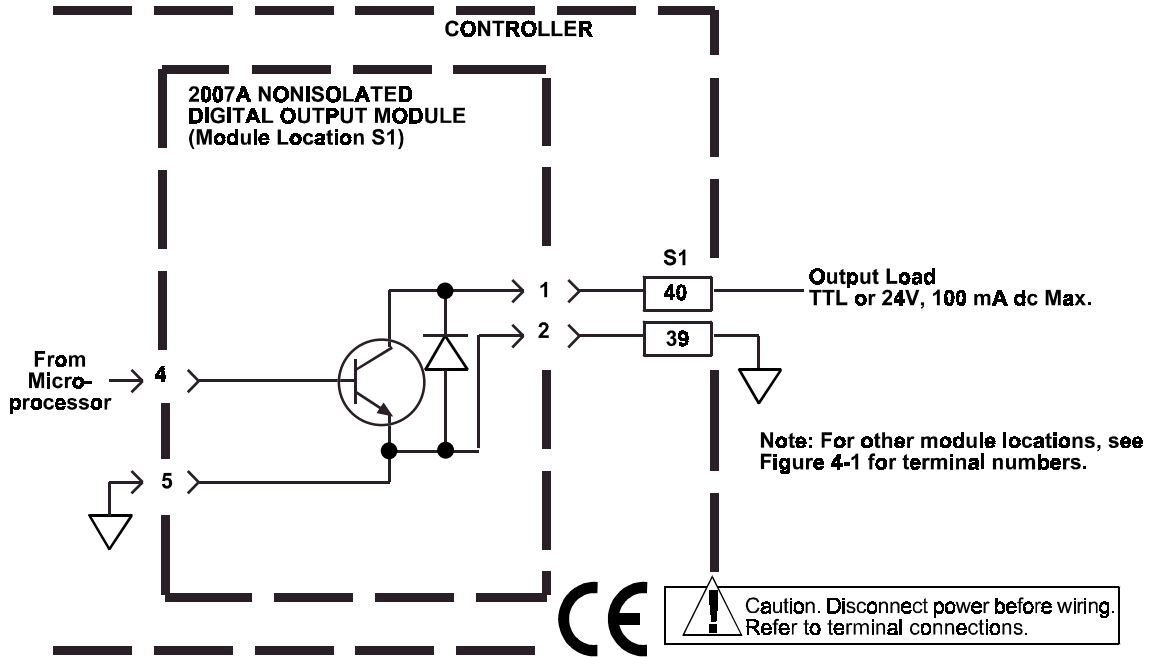

Figure 4-13. Typical Connections for a 2007A Nonisolated Digital Output Module

4.4.4 2011A Dual Mechanical Relay Outputs (DDOM)

Make mechanical relay output connections as shown in Figure 4-14. Output specifications are:

DUAL MECHANICAL RELAY OUTPUTS	
Configuration	Dual relays (NO/NO, NC/NC, NO/NC)
Power supply range	+ 5 VDC \pm 10%
Max Input Current	-10.0 mA DC
Contact load	3A at 60 VAC or 30 VDC
Contact resistance	0.10 ohms maximum
Isolation	250 Vrms (contacts to coil)
Current rating	3A per relay
Response time	10 msec

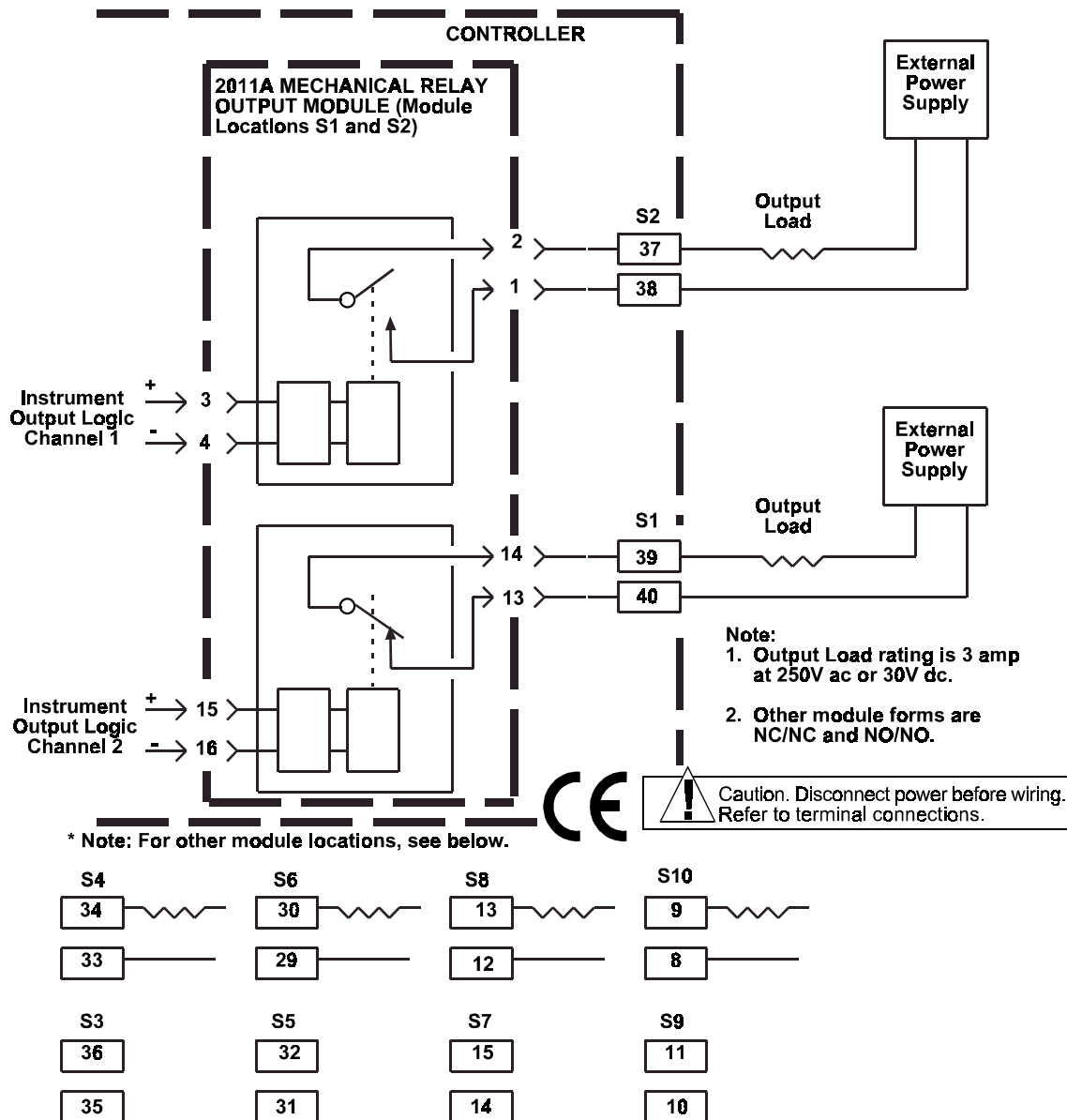

Figure 4-14. Typical Connections for a 2011A Mechanical Relay Output Module (Dual SPST, NO/NC)

MODULAR I/O CONNECTIONS

4.4.5 2011A Form C Mechanical Relay Outputs (WDOM)

Make mechanical relay output connections as shown in Figure 4-15.
 Wire rating: 600 V, -20°C +105°C UL, CSA approved. Output specifications are:

FORM C MECHANICAL RELAY OUTPUT	
Configuration	Form C single relay
Power supply range	+ 5 VDC ±10%
Max Input Current	-10.0 mA DC
Contact load	3A at 60 VAC or 30 VDC
Contact resistance	0.10 ohms maximum
Isolation	250 Vrms (contacts to coil)
Current rating	3A per relay
Response time	10 msec

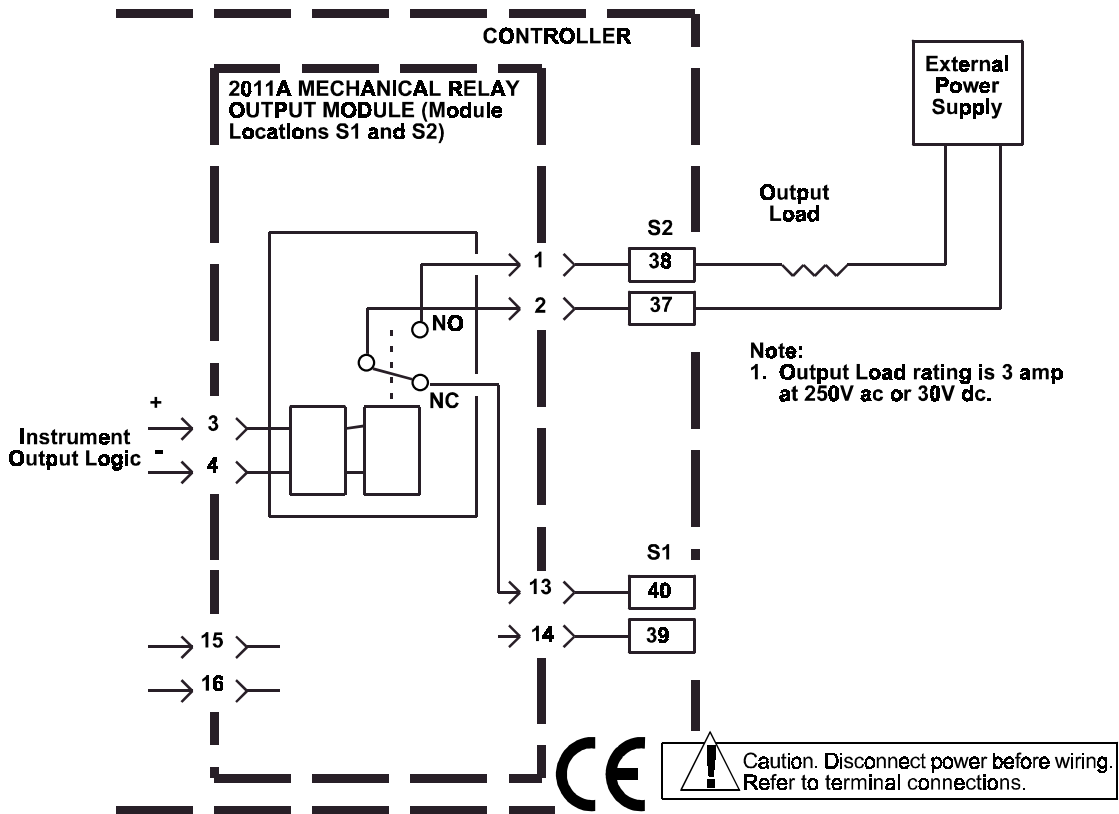

* Note: For other module locations, see below.

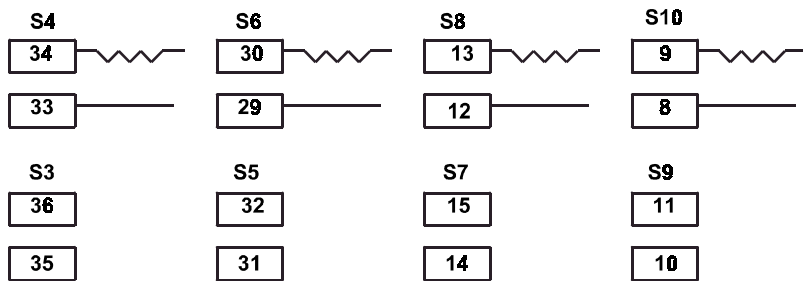

Figure 4-15. Typical Connections for a 2011AZ10200A Mechanical Relay Output Module (Form C)

5 COMMUNICATIONS CONNECTIONS

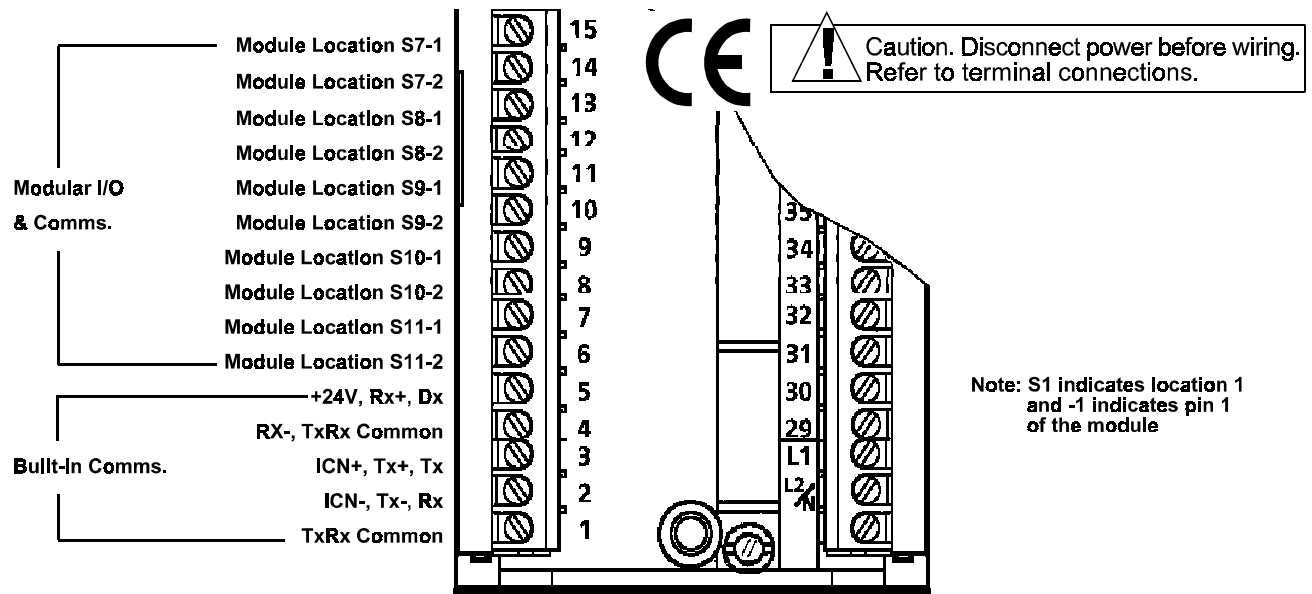

Figure 5-1. Terminal Identifications for Communications Network Connections

5.1 GENERAL

Read this section thoroughly before making connections. Installation personnel should be qualified technicians.

The controller provides communications capability for both ICN and Modbus networks. Two serial communication ports are available permitting the controller to communicate on two different networks simultaneously. Port 1 can use either built-in or modular communication drivers. Port 2 requires a modular driver. Communications connections are made to the terminals shown in Figure 5-1. The communications network diagrams in this section show connections for both the built-in and modular communications circuits.

In addition to the network communications capability, the controller provides an RS-232 communications port in the bottom of the front panel. This port permits connection of a portable computer for data base configuration using 2006S Application Builder Software.

COMMUNICATIONS CONNECTIONS

5.2 COMMUNICATION CONNECTION GUIDELINES

The wiring connections described in this section are made with the controller installed in its operating location and with the power off. All connection terminals are located under a cover on the back of the instrument housing. Figure 5-1 shows the communication connection terminals with the cover removed.

The recommended procedure for making communications connections is as follows:

1. Communications port 1 serves either the built-in communications circuits or I/O module location S10 (S10 and S9 if module is double wide). It is recommended that the built-in communication circuit be used for port 1. This leaves the module locations available for other purposes.
2. Communications port 2 serves I/O module location S8 (S8 and S7 if module is double wide). If required, a second communication network can be supported via this modular connection.
3. When using communication port 1, a communications jumper on the carrier board, Figure 5-2, must be positioned to select the communication type for the built-in circuits, or to deselect the built-in circuit if a module is used.
4. The built-in communications circuits are isolated from all other circuits. Terminal 1 (TX & RX common) is the communications circuit common for these built in circuits. When built-in communication is used, connect terminal 1 of each instrument on the communication bus together. This common line must be connected to ground at some point in the system to prevent the possible build up of a static charge, reduce noise pick up, and comply with EU EMC requirements.
5. Communications wiring should be shielded twisted pairs. Detailed cable requirements are provided in **Sections 5.4 and 5.5**.
6. The cable shields must be connected to a good noise free ground. Normally this should be one of the terminals identified as chassis in Figure 3-1. Alternatively, it is acceptable to use the shield to connect the commons among the instruments. If this arrangement is used, noise rejection may not be optimal.
7. Route communications wiring from the top left hand side of the housing and distribute to appropriate terminals.
8. Use a small, flat-head screwdriver to loosen appropriate connection screws and clamps on terminal blocks.
9. Strip approximately 5/16 inch (8 mm) of insulation from the end of each wire, insert wires at assigned terminals, and secure terminal screws and clamps.
10. Make wiring connections using the following procedures:
 - a. Front Panel RS-232 Communications Connections - **Section 5.3**.
 - b. Instrument Communications Network (ICN) Connections - **Section 5.4**.
 - c. Modbus Network Connections - **Section 5.5**.
11. After all connections are completed and checked, the ac power wiring can be connected at the distribution panel (ac source).

* **NOTE:** Before putting the controller into operation, it must be configured using either the front panel keys or the 2006S Application Builder Software. See **Section 1.1.2** for related documents.

COMMUNICATIONS CONNECTIONS

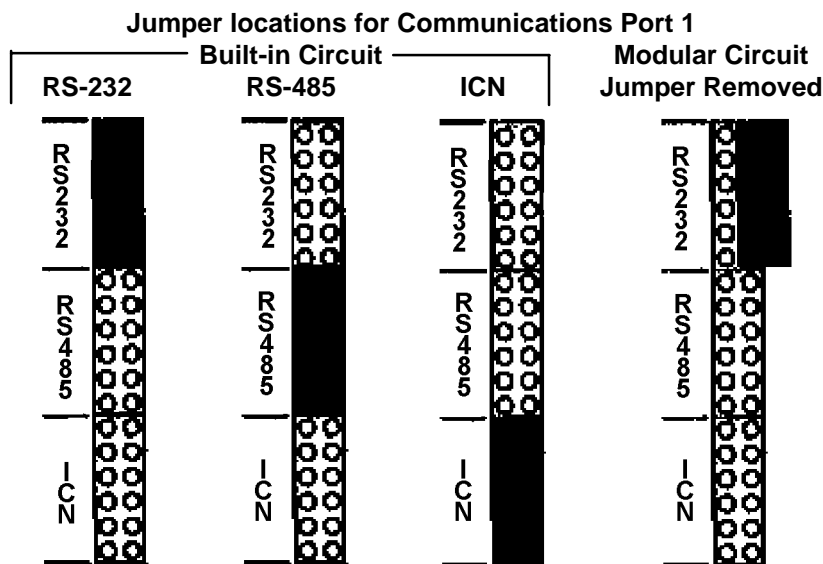
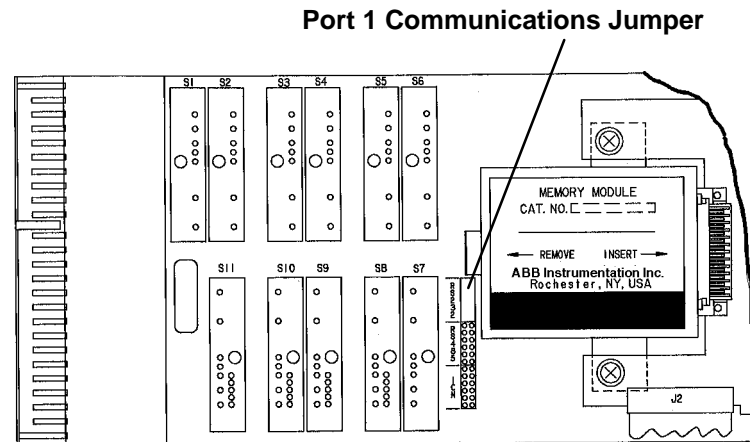

Figure 5-2. Locations for Port 1 Communications Jumper

5.3 FRONT PANEL RS-232 COMMUNICATIONS CONNECTION

The RS-232 communication port in the instrument front panel, Figure 1-1 (NOT present with NEMA 4), is used exclusively for data base configuration via connection of a portable computer. Use of this RS-232 port is subject to the following requirements:

- Connection to the port must be made using a cable which is available as an accessory to the instrument. The cable is terminated at one end with a plug-in connector for the instrument port, and at the other end with a connector compatible with a computer serial communication port.
- The communication jumper, Figure 5-2, must be positioned for RS-232 communication.

COMMUNICATIONS CONNECTIONS

- If connections are made to the built-in communication terminals, Figure 5-1, the connections must support RS-232 communication as shown in Figure 5-4, otherwise the RS-232 port in the front panel is not functional.
- The instrument data base must be configured to provide RS-232 communication on the built-in circuit; this is the default configuration.

When the built-in RS-232 circuit is being used for network communication, making a connection to the front panel RS-232 port disables the network receive function so that the instrument can receive data only from the device connected to the port. The transmit line is not affected.

5.4 INSTRUMENT COMMUNICATIONS NETWORK (ICN) CONNECTIONS

An example of a typical ICN configuration with both modular and built-in connections is shown in Figure 5-3.

5.4.1 Cable Requirements

The length of the ICN is the sum of the lengths of the physical two-wire bus between each node on the ICN. If the network includes MOD 30 instruments, the length of any MOD 30 instrument cables between the nodes and the instruments must be included in the total length. This length can be up to 2000 ft (609.6 m). Cable requirements for an ICN are dependent upon the length of the ICN as described below.

- When the total length is 500 ft (150 m) or less, use 18 AWG (1 mm) shielded twisted pair cable.
- When the total length is between 500 and 1500 ft (150 and 450 m):
 - Entire length of the ICN must be at virtually the same potential and voltage drop between any two points on ICN must not exceed 3V.
 - Cable capacitance for an ICN must be between 18 and 25 pf/ft (60-83 pf/m).
- When the total length exceeds 1500 ft (450 m) or if the ICN must be routed through high noise (EMI/RFI) environments, use 22 AWG (0.64 mm) shielded cable. If an ICN must be run next to power lines or other unusual noise frequencies, contact your service representative for assistance.

5.4.2 Addresses

Each device on an ICN must be assigned a unique address. Addresses are in the range of 0 through F hex (0 through 15 decimal). The address for the built-in circuit is configured through the front face of the instrument in Device Setup (see IB-1800R-OPR Setup Section). Addresses for modular circuits are set at the module as shown in Figure 5-3.

COMMUNICATIONS CONNECTIONS

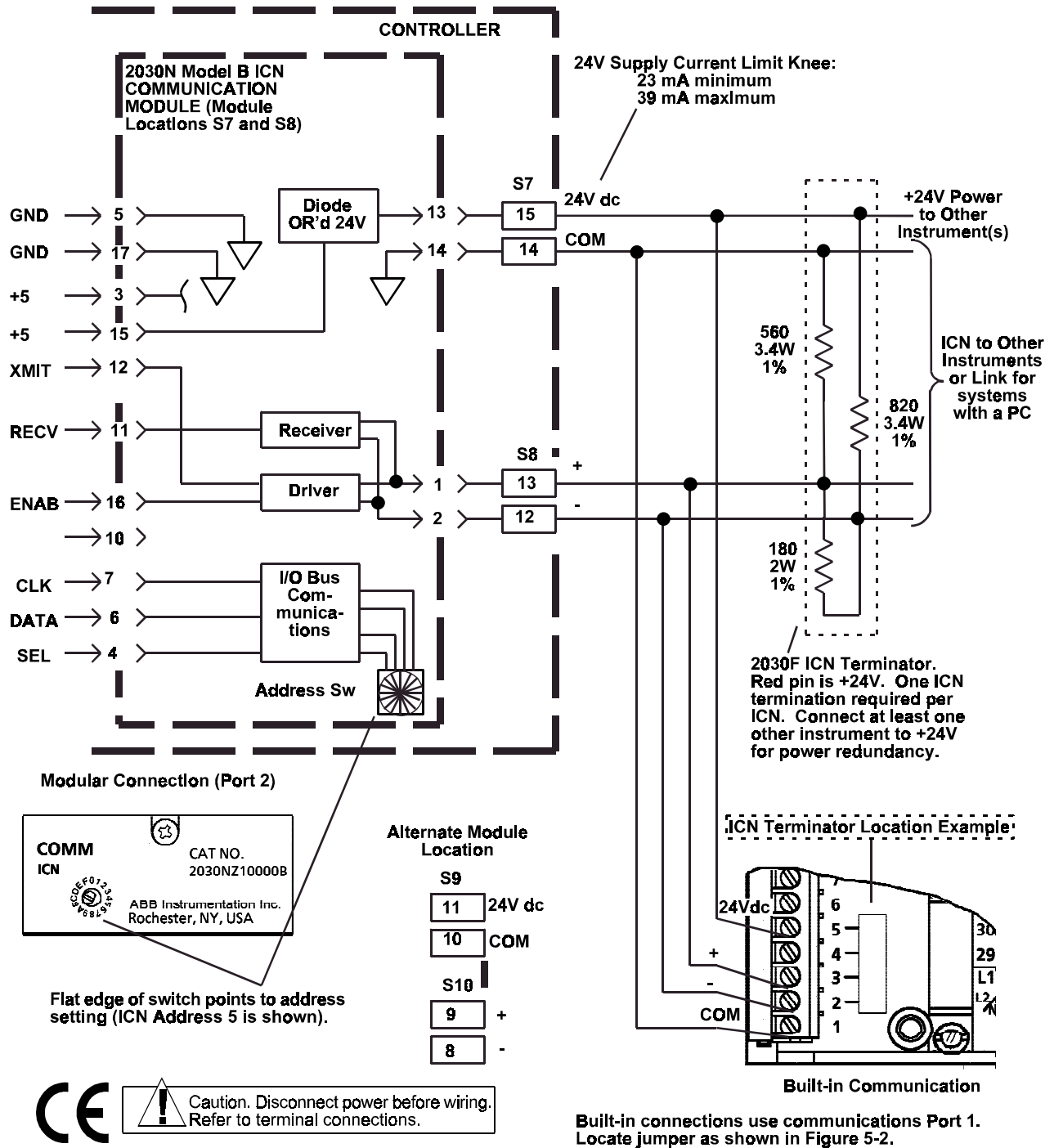

Figure 5-3. ICN Connections for Built-in and Modular Communication Circuits

COMMUNICATIONS CONNECTIONS

5.4.3 Termination

One set of ICN termination resistors must be installed on each ICN to prevent noise from being picked up by the ICN circuitry and generating a diagnostic alarm. The ICN termination scheme requires a nominal 24 volt DC power supply that can supply 15.4 mA. This supply is provided by both the built-in and modular circuits. The termination resistor network is provided in a 2030FZ00001A ICN Terminator. The terminator can be conveniently connected to an ICN at built-in terminals 2 - 5 as shown in Figure 5-3. Note that the terminator is connected to common via terminal 4 which is internally connected to terminal 1 (communications common) for ICN communication. The terminator can also be connected at the appropriate four terminals when a communications module is used.

Other factors affecting the termination scheme are as follows.

- The ICN cable shields should be connected directly to chassis ground **at one end only**.
- Be sure each network has only one terminator. If the controller is connected to an existing MOD 30 ICN, the network is already terminated and a terminator must not be connected to any new device.

5.5 MODBUS NETWORK CONNECTIONS

5.5.1 General

Numerous Modbus network connection arrangements are possible. Selection of a specific arrangement depends on the requirements of the application. The connection diagrams shown in this section provide typical examples of connection schemes which meet all the functional requirements of the Modbus protocol and the built-in and modular communication circuits.

Master and Slave Designations

The controller can function as either a Modbus master or Modbus slave. This functionality is determined by the configuration of the MSC block.

Communications Parameters

The baud rates available are: 150, 300, 600, 1200, 2400, 4800, 9600, 19200 or 38400. Parity can be none, even or odd, and there can be either 1 or 2 stop bits. These parameters are configurable via the MSC block.

The transmission mode of Modbus networks using either the built-in or modular circuits is RTU (Remote Terminal Unit).

RS-485 Network Considerations

The RS-485 specification allows as many as 32 devices on any given network. The number of devices can be increased by the use of repeaters. The Modbus network supports as many as 247 slave devices.

RS-485 Cable Requirements

For short runs of 10 to 25 ft (3 to 6m), virtually any 2-wire shielded or twisted pair is suitable. For runs up to 1000 ft (305 m), Belden 9502 Cable or an equivalent cable is recommended. This cable is a dual 24 AWG (0.5 mm) twisted pair with an overall foil shield. A drain wire is provided for grounding the shield. For runs up to 4000 ft (1219.2 m), Belden 9729 Cable or an equivalent cable is recommended. This cable is a dual 24 AWG (0.5 mm) twisted pair with a foil shield for each pair. The cable insulation is low dissipation (polypropylene). Two separate drain wires are provided for grounding the shields

* **NOTE:** Heavy braid shield cable may be required for certain noisy environments.

Addresses

Each slave on a Modbus network must have a unique address. Addresses 1 through 247 (01 through f7 in hexadecimal) are supported by the Modbus protocol. Addresses for the built-in circuit are assigned by configuration of a data base attribute. Addresses for modular circuits are set at the module as shown in Figure 5-7.

Communication Defaults

The 2033N and 2034N RS-485 modules have a COMM DEFAULTS switch which provides for communication with the module when its configuration is unknown. When the switch is set at YES, a set of default parameters is invoked. The parameters are: 9600 Baud, no parity, one stop bit, eight data bits, and the port functionality is slave.

5.5.2 RS-232 Modbus Communication

The built-in and modular circuits for RS-232 communication use a driver/receiver which supports a point-to-point Modbus network. The modular circuit is contained in a 2033N communications module. These circuits meet all RS-232C and V.28 specifications. They have a $\pm 9V$ output swing with a +5V supply, and $\pm 30V$ receiver input levels. All field connection terminals are optically isolated from the instrument circuitry. The maximum network cable length is 50 feet.

Both the built-in and modular circuits support the Extended Modbus protocol which provides full communications functionality between controllers, and between the controllers and the Application Builder software.

! CAUTION: If the modular communication option is used, be sure the module is wired properly before applying power. Although this module is isolated, it can be damaged if excessive voltage is applied across the input pins. This module is not a drop-in replacement for the ICN module (2030N), and will be damaged if ICN level voltages are applied to the input pins.

Connections for a typical RS-232 Modbus network using the built-in circuit is shown in Figure 5-4, and connections using the modular circuit are shown in Figure 5-5. Either a computer or the controller can act as the Modbus master.

COMMUNICATIONS CONNECTIONS

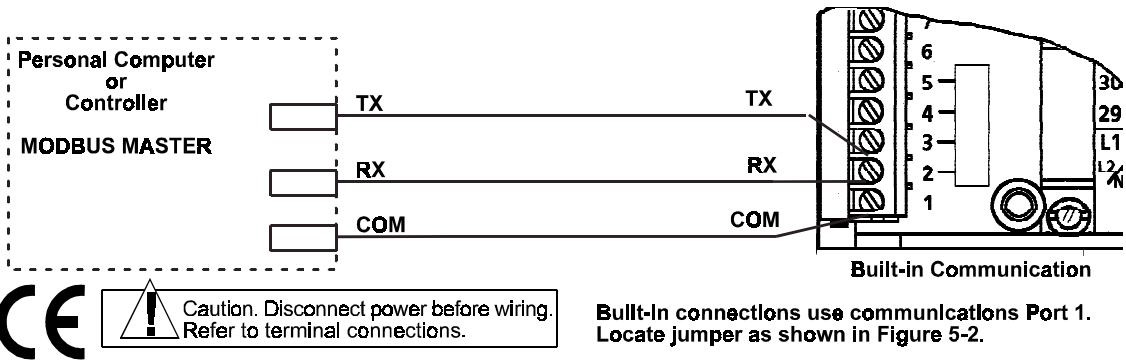

Figure 5-4. Typical Network Connections for Built-In Modbus RS-232 Communication

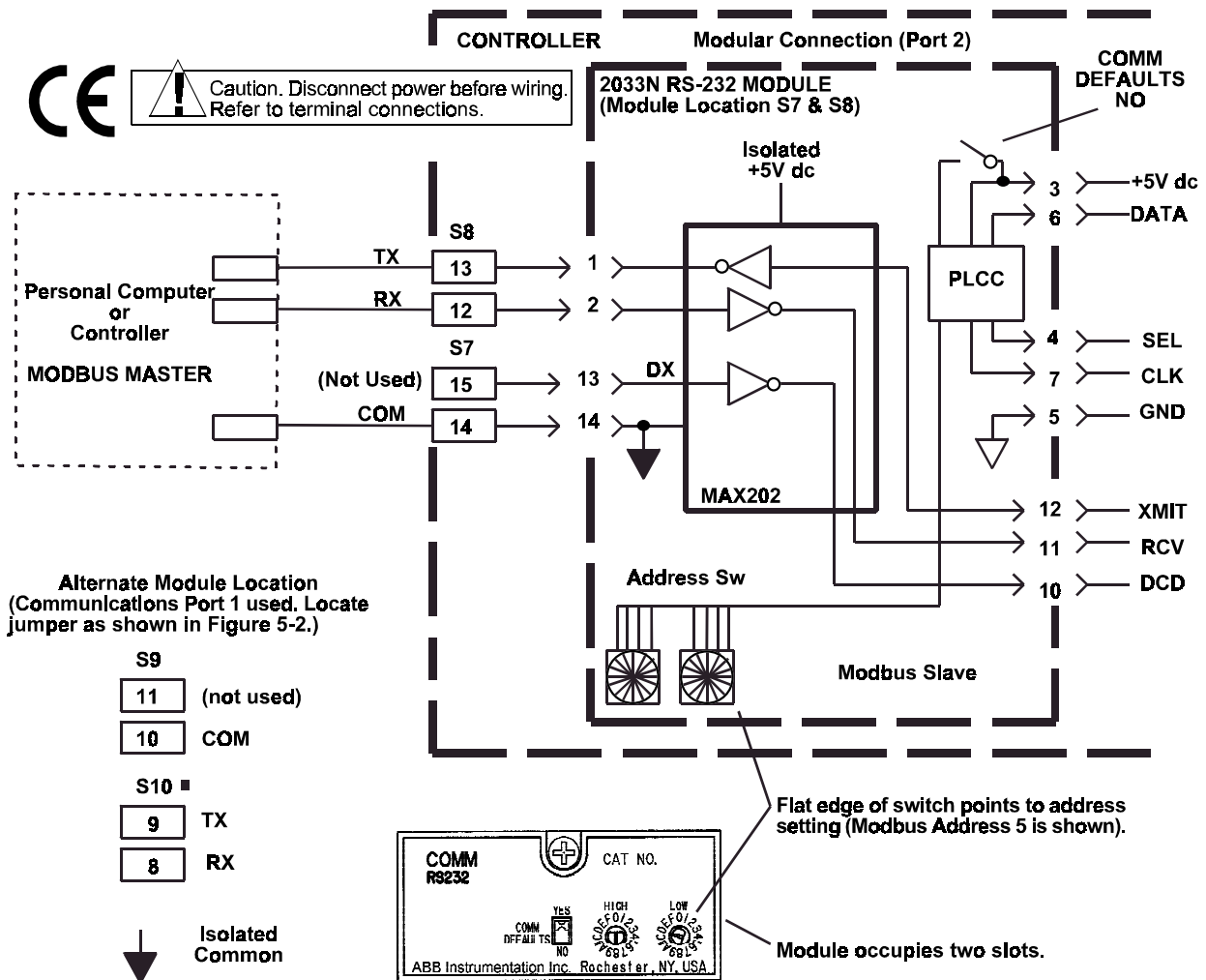

Figure 5-5. Typical Network Connections for Modular Modbus RS-232 Communication

5.5.3 RS-485 2-Wire Modbus Communication

The built-in and modular circuits for RS-485 2-wire communication use a transceiver which supports a 2-wire point-to-point or point-to-multipoint Modbus network. The modular circuit is contained in a 2032N communications module. All field connection terminals are isolated from the instrument circuitry.

! CAUTION: If the modular communication option is used, be sure the module is wired properly before applying power. Although this module is isolated, it can be damaged if excessive voltage is applied across the input pins. This module is not a drop-in replacement for the ICN module (2030N), and will be damaged if ICN level voltages are applied to the input pins.

Connections for a typical RS-485 2-wire Modbus network are shown in Figure 5-6. In this network, the personal computer acts as the Modbus master and the controller is the slave. The master is responsible for providing the bus stabilizing pull-up and pull-down resistors which keep the bus in a MARK/IDLE state when all the transmitters are tri-stated. Connect 120 ohm termination resistors across the transmission line at both ends as shown. The termination resistors may not be required if the line length is very short.

The built-in communications circuit provides a communications common connection at terminal 1 to provide improved noise resistance. The modular circuit does not use a communications common. When using the built-in circuit, connect the communications common as follows:

- Connect to terminal 1 of all instruments communicating on the network via the built-in circuit.
- Connect to the RS-485 interface board in the personal computer if a communications common terminal is available.
- Connect to ground at some point in the system.

COMMUNICATIONS CONNECTIONS

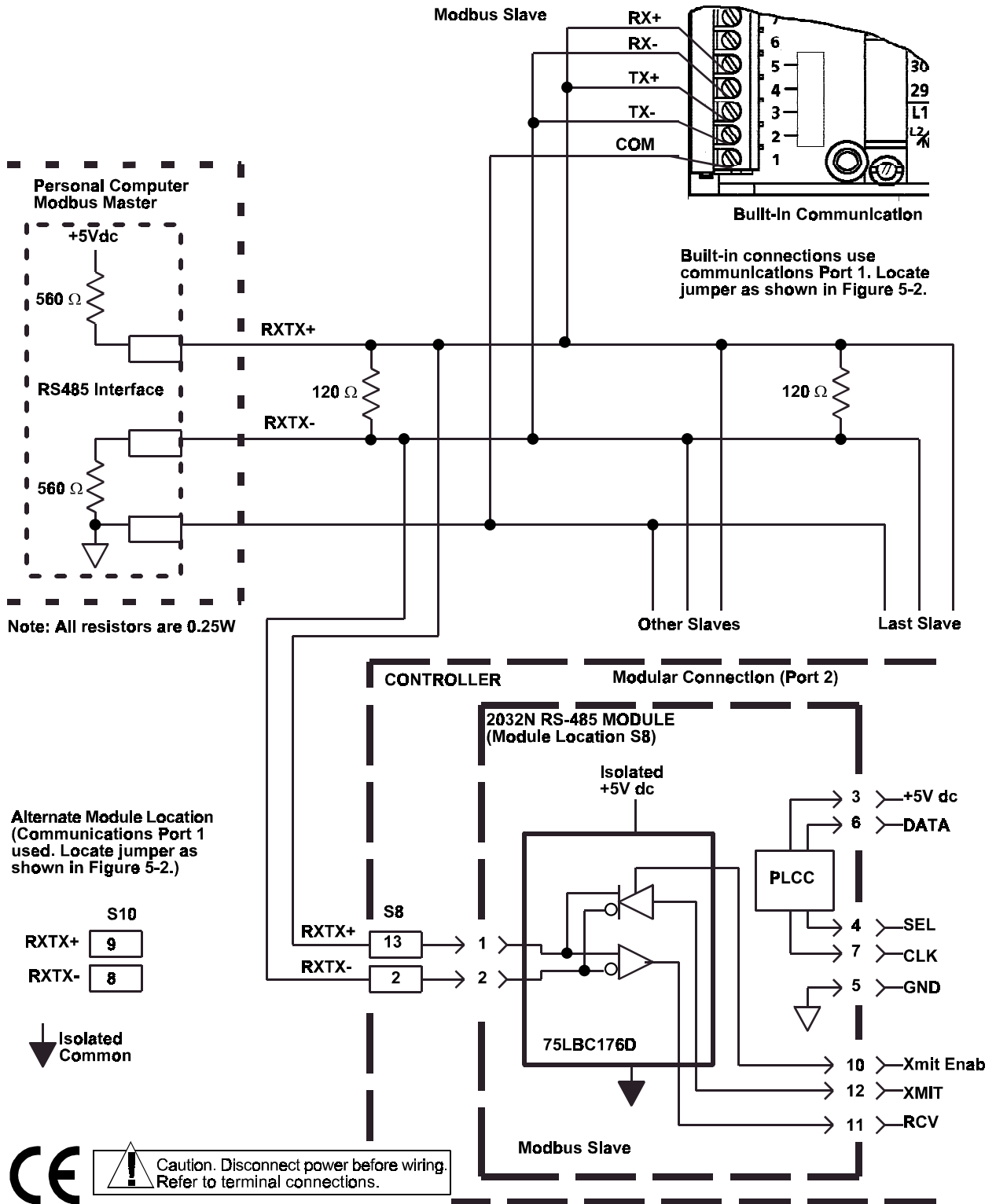

Figure 5-6. Typical Modbus Connections for an RS-485, 2-Wire Network

5.5.4 RS-485 4-Wire Modbus Communication

The built-in and modular circuits for RS-485 4-wire communication use a pair of transceivers which support a 4-wire point-to-point or point-to-multipoint Modbus network. The modular circuit is contained in a 2034N communications module. All field connection terminals are isolated from the instrument circuitry.

Both the built-in and modular circuits support the Extended Modbus protocol which provides full communications functionality between controllers, and between a controller and the Application Builder software.

! CAUTION: If the modular communication option is used, be sure the module is wired properly before applying power. Although this module is isolated, it can be damaged if excessive voltage is applied across the input pins. This module is not a drop-in replacement for the ICN module (2030N), and will be damaged if ICN level voltages are applied to the input pins.

P C Master

The diagram in Figure 5-8 shows connections for a typical RS-485 4-wire Modbus network in which a personal computer acts as the Modbus master and the controller is the slave. The master is responsible for providing the bus stabilizing resistors. When using the modular communications circuit, the module provides the slave function, and the TERM switch on the module must be set at NO to disconnect the resistors inside the module. Connect 120 ohm termination resistors across the transmission line at both ends as shown. The termination resistors may not be required if the line length is very short.

Controller Master

The diagram in Figure 5-9 shows connections for a typical RS-485 4-wire Modbus network in which one controller acts as the master, and the other controllers on the network are slaves. In this network, it is recommended that the modular communications circuit be used in the master because the 2034N module provides the required bus stabilizing resistors. The TERM switch on the master module must be set at YES to connect the resistors to the network. The TERM switch on each slave module must be set at NO to disconnect the resistors inside the module. Connect 120 ohm termination resistors across the transmission line at both ends as shown. These resistors may not be required if the line length is very short.

Communications Common

The built-in communications circuit has a communications common connection at terminal 1 to provide improved noise resistance. The modular circuits do not use a communications common. When using the built-in circuit, connect a communications common line as follows:

- Connect to terminal 1 of all instruments communicating on the network via the built-in circuit.
- When a personal computer or other host device is on the network, connect to the RS-485 interface board if a communications common terminal is available.
- Connect to ground at some point in the system.

COMMUNICATIONS CONNECTIONS

4-Wire/2-Wire Network

When several slaves on a network require only read and write capability, a mixture of 2-wire and 4-wire communication can be used to save slot space and transmission cable as shown in Figure 5-10. This arrangement allows a series of 2-wire slave controllers to be connected to a 4-wire master controller. The master provides the required bus stabilizing resistors via a 2034N module. The slaves are adequate for the read/write function using either the built-in circuit or a 2-wire 2032N single wide module.

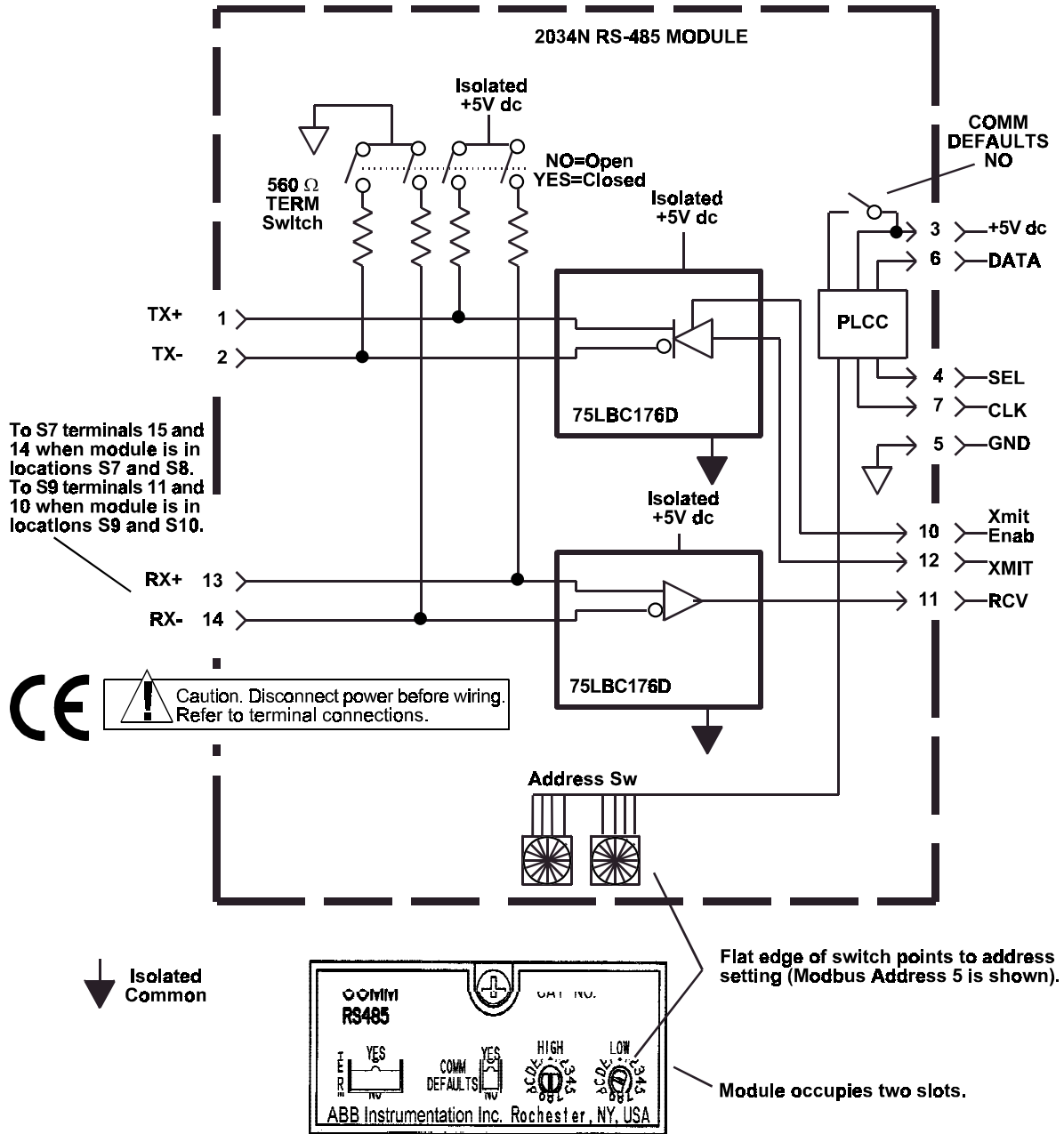

Figure 5-7. Simplified Diagram, 2034N RS-485, 4-Wire Module

COMMUNICATIONS CONNECTIONS

Built-in connections use communications Port 1. Locate jumper as shown in Figure 5-2.

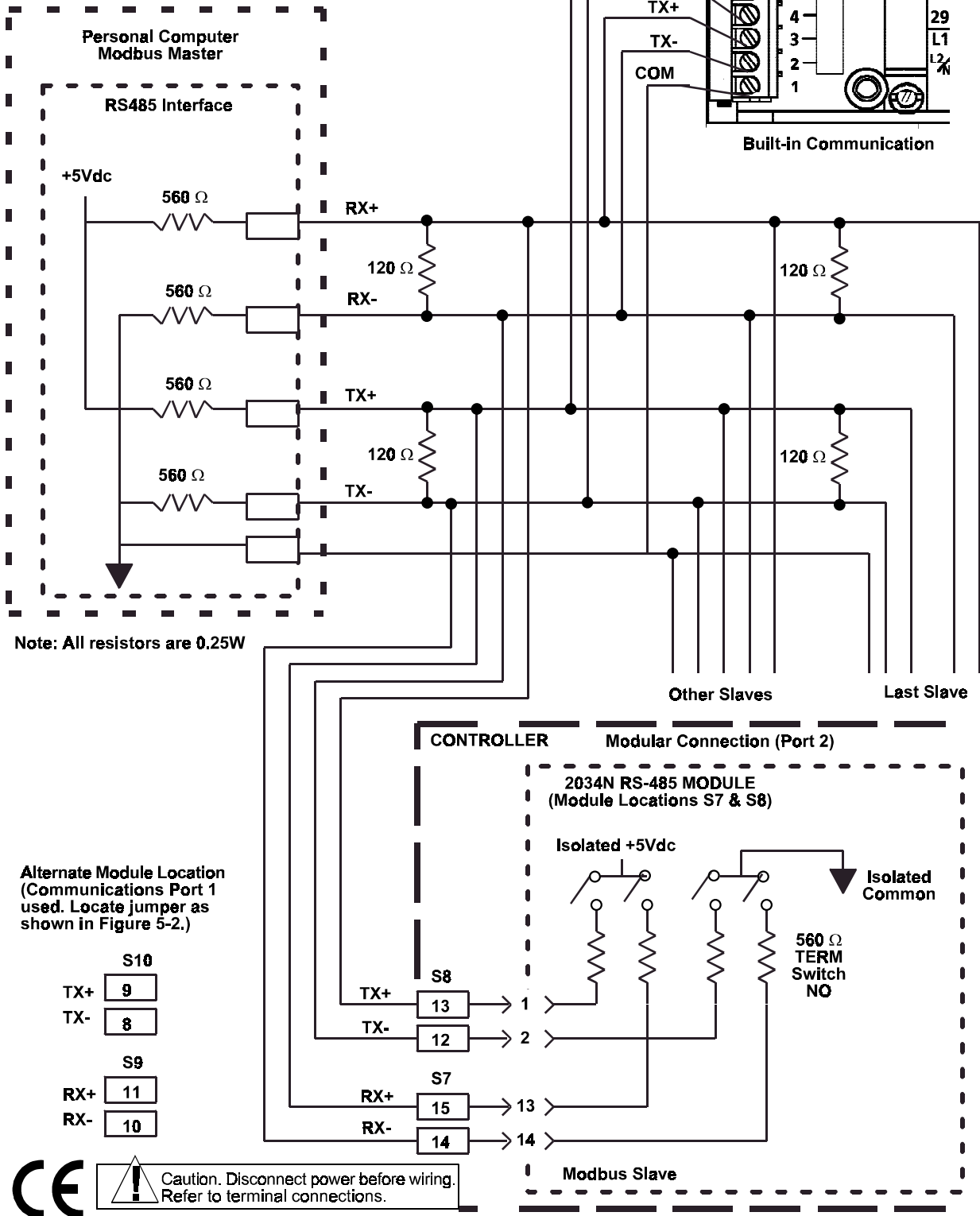

Figure 5-8. Typical Modbus Connections for an RS-485, 4-Wire Network (Slave Controller)

COMMUNICATIONS CONNECTIONS

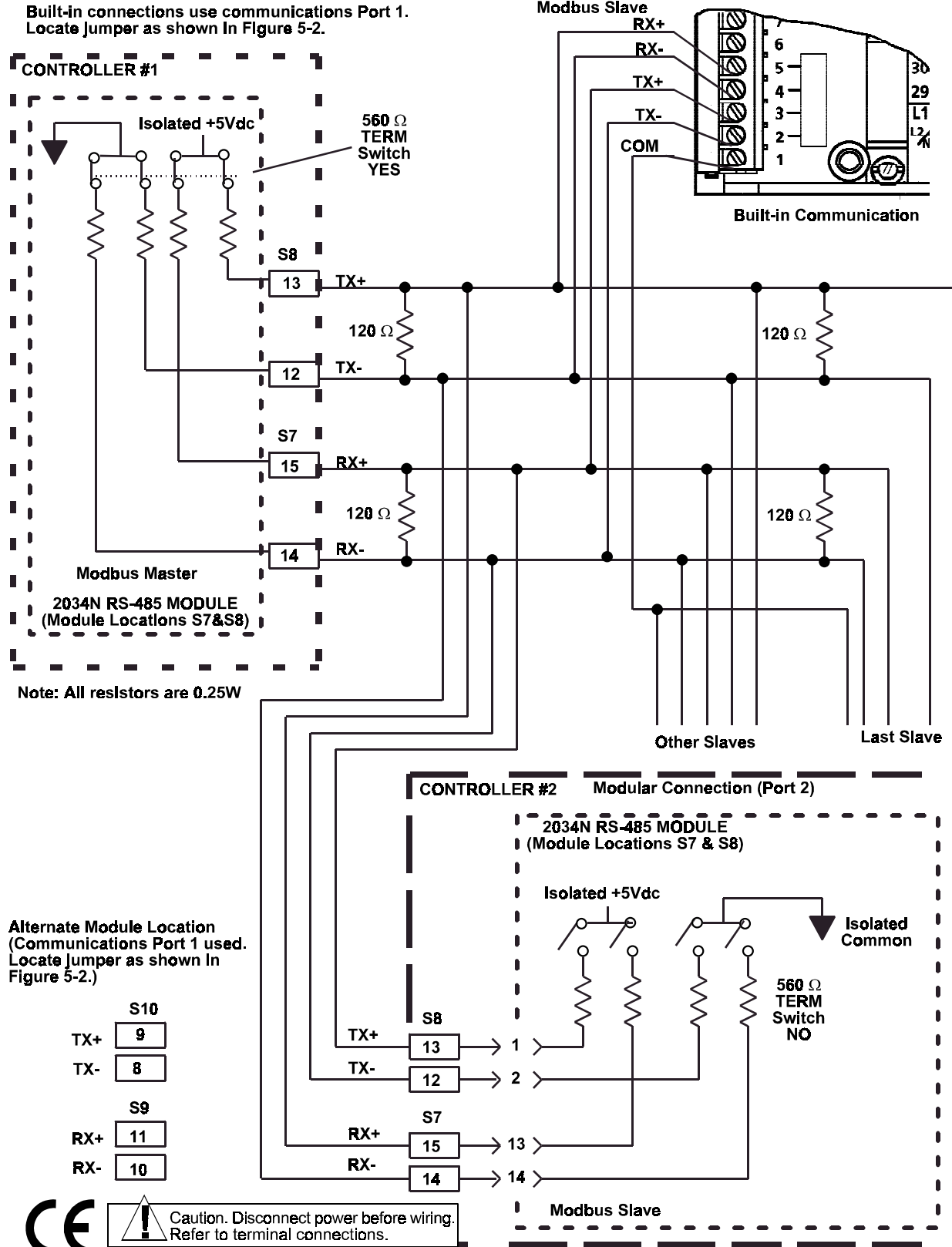

Figure 5-9. Typical Modbus Connections for an RS-485, 4-Wire Network (Master Controller)

COMMUNICATIONS CONNECTIONS

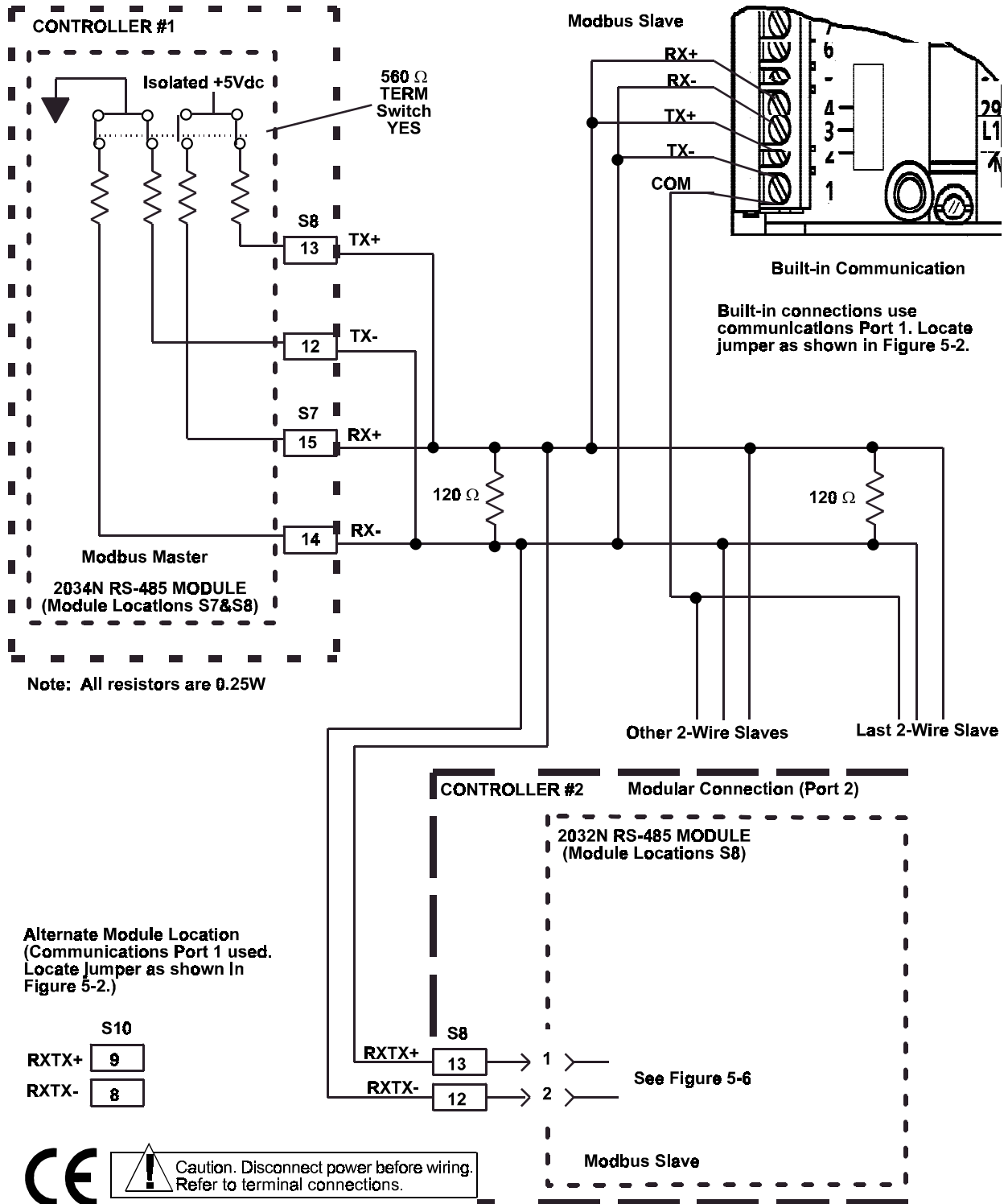

Figure 5-10. Typical Modbus Connections for a 4-Wire Master with 2-Wire Slaves

COMMUNICATIONS CONNECTIONS

APPENDIX A

A.1 MAINTENANCE

CAUTION. Disconnect power before servicing.

Use lens cleaning tissue or a soft cloth for cleaning the display overlay. Do not use paper towels or industrial wipes. Remove dust from the rear of the instrument by removing it from the instrument housing and spraying exposed surfaces with non-corrosive, non-toxic, non-flammable inert dusting gas.

A.2 PLANNING FORMS

The forms included in this appendix may be copied as necessary to record controller current consumption, the I/O plan, and wiring connection data.

APPENDIX A

CURRENT CONSUMPTION PLANNING FORM

CONTROLLER NUMBER _____

BUILT-IN I/O CURRENT CONSUMPTION

Description	Max. Supply Current (mA)	No. Used (1 or 2)	Current Subtotals
Transmitter Power Supply	150		
20 mA Output	140		
50 mA Output	410		
ICN Terminator	100		
Built-in I/O Current Subtotal	////////	////////	

MODULAR I/O CURRENT CONSUMPTION

Catalog No.	Description	Max. Supply Current (mA)	No. of Modules	Current Subtotals
2001A Model B	Voltage Input	80		
2002A Model B	Current Input	80		
2003A Model A	Current Output	350		
2004A Model A	Solid State Relay Input	12		
2005A Model A	Solid State Relay Output	12		
2006A Model A	Nonisolated Digital Input	10		
2007A Model A	Nonisolated Digital Output	20		
2009A Model B	RTD Input	80		
2011A Model A	Mechanical Relay Output	140		
2012A Model B	Current Input with 2-Wire Transmitter	350		
2013A Model B	Thermocouple Input	80		
2020N Model B	Remote I/O Interface	400		
2030N Model B	ICN Communication With terminator	500		
	ICN Communication Without terminator	300		
2032N Model C	RS-485 2-Wire Communication	180		
2033N Model A	RS-232 Communication	180		
2034N Model A	RS-485 4-Wire Communication	180		
	Modular I/O Current Subtotal	////////	////////	

TOTAL CURRENT CONSUMPTION (must not exceed 5000 mA)

Base Instrument Load	1220 mA
Built-in I/O Current Subtotal	mA
Modular I/O Current Subtotal	mA
Total Current Consumption	mA

MOD 30ML I/O PLANNING FORM

Controller No. _____

Built-in I/O

Input 1: _____

Output 1: _____

Input 2: _____

Output 2: _____

Communications: _____

Modular I/O

I/O Module Locations

No.	Module	No.	Module	No.	Module	No.	Module	No.	Module	No.	Module
S1		S2		S3		S4		S5		S6	
S7		S8		S9		S10		S11			////////

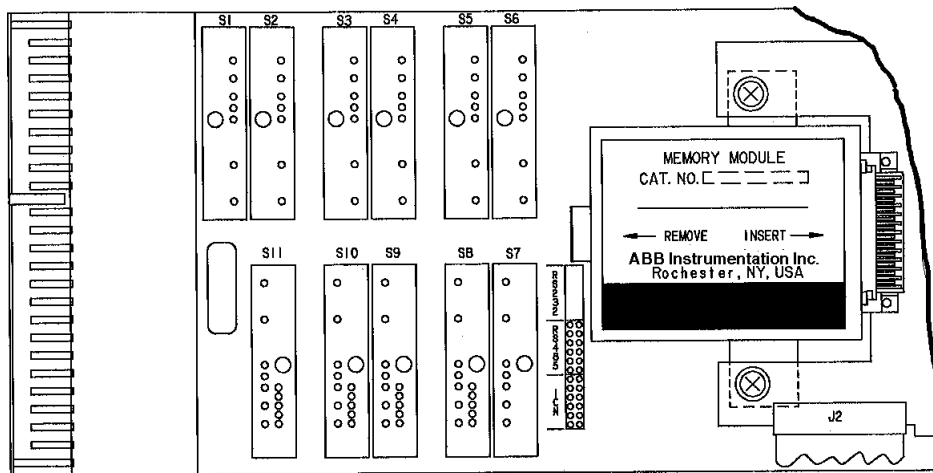

PRODUCTS AND SERVICING

A Comprehensive Instrumentation Range

Sensors, transmitters and related instruments for flow, temperature, pressure, level and other process variables

Flowmeters

electromagnetic, ultrasonic, turbine, differential pressure, Wedge, rotary shunt, coriolis.

Differential Pressure transmitters

electronic and pneumatic.

Temperature

sensors and transmitters, fiber optic systems.

Pressure transmitters

Level

sensors and controllers.

Tank gauging systems

Cable-length measuring systems

Indicators, recorders, controllers and process management systems

Recorders

circular and strip-chart types - single and multi-point - for temperature, pressure, flow and many other process measurements.

Controllers

digital display, electronic, pneumatic. Discrete single-loop and multi-loop controllers which can be linked to a common display station, process computer or personal computer.

Pneumatic panel or rack-mounted display and control instrumentation

Liquid and gas monitors and analyzers for on-line and laboratory applications

Sensors

pH, redox, selective ion, conductivity and dissolved oxygen.

Monitors and Analyzers

for water quality monitoring in environmental and power generation and general industrial applications.

Packaged analytical instrumentation laboratories

Gas analyzers

Zirconia, paramagnetic, infrared, thermal conductivity.

Servicing

ABB Instrumentation provides a comprehensive after sales service via a Worldwide Service Organization. Contact one of the following offices for details on your nearest Service and Repair Center.

United Kingdom

London
ABB Kent-Taylor Limited
Tel: (1480) 470781
FAX: (1480) 470787

United States of America

Rochester, New York
ABB Instrumentation Inc.
Tel: (716) 292-6050
Fax: (716) 273-6207

Italy

Lenno (Como)
ABB Kent-Taylor SpA
Tel: (0344) 58111
Fax: (0344) 56278



The Company's policy is one of continuous product improvement and the right is reserved to modify specifications contained herein without notice.

©1998 ABB Instrumentation

IB-1800R-INS, Issue 4.1 1/98

ABB Kent-Taylor Ltd.

St. Neots Cambs.
England, PE19 3EU
Tel: (01480) 475321
Fax: (01480) 217948

ABB Instrumentation Inc.

P.O. Box 20550
Rochester, New York 14602-0550
Tel: (716) 292-6050
Fax: (716) 273-6207

ABB Kent-Taylor SpA

22016 Lenno
Como, Italy
Tel: (0344) 58111
Fax: (0344) 56278