

Ultra-compact Remote I/O Modules to Match Most Applications

- 4-point, 8-point and 16-point models
- 4-point models measure 82 W x 32 D x 64.5 H mm; 8- and 16-point models measure 115 W x 32 D x 63 H mm
- Two-conductor cable communications to Omron Wired Remote I/O Master Modules (C200H-RM201 and C500-RM201) simplifies installation
- Two independent power supplies can be used since I/O terminals are isolated from the internal circuits
- Optional DIN track mounting brackets available



Ordering Information

■ REMOTE TRANSISTOR I/O MODULES

I/O classification	Internal I/O circuit common	I/O points	Rated voltage	I/O rated voltage	Part number
Input	NPN (+ common)	4	24 VDC	24 VDC	G730-VID04 DC24
Output	NPN (- common)				G730-VOD04 DC24
Input	NPN (+ common)	8			G730-VID08 DC24
	PNP (- common)				G730-VID08-1 DC24
Output	NPN (+ common)				G730-VOD08 DC24
	PNP (- common)				G730-VOD08-1 DC24
Input	NPN (+ common)	16			G730-VID16 DC24
Output	NPN (- common)				G730-VOD16 DC24

■ DIN TRACK MOUNTING ADAPTERS

Description	Applicable remote I/O modules	Part number
DIN track adapter	G730-V□D04	G730-Y31
	G730-V□D08	G730-Y30
	G730-V□D16	

Specifications

■ RATINGS

Inputs

G730-VID04, G730-VID08, G730-VID08-1, G730-VID16

Input current	10 mA max./point
ON delay	1.5 ms max.
OFF delay	1.5 ms max.
ON voltage	5 VDC max. at 24 VDC
OFF current	0.2 mA min.
Insulation method	Photocoupler
Input indicators	LED (orange)

Note: Connection conditions to input devices are indicated.

Outputs

G730-VOD04, G730-VOD08, G730-VOD08-1, G730-VOD16

Rated output current	0.3 A/point (See Note)
Residual voltage	0.6 V max.
Leakage current	0.1 mA max.
Insulation method	Photocoupler
Output indicators	LED (orange)

Note: Use at 2.4 A or less per common.

■ CHARACTERISTICS

Master module	For SYSMAC BUS Wired Remote I/O Systems: C200H-RM201, C500-RM201
Communication method	Two-conductor, half duplex
Synchronization method	Asynchronous
Transmission distance	200 m (total length)
Transmission speed	187.5 kbps
Transmission path	Two-conductor cable (VCTF 0.75 x 2 C is recommended)
Interface	RS-485
Operating voltage range	24 VDC $+10\%$ / -15%
Current consumption (See Note)	Output: 80 mA max. at 24 VDC Input: 70 mA max. at 24 VDC
Insulation resistance	20 M Ω min. at 250 VDC
Dielectric strength	500 VAC for 1 min between the input terminals and power supply and transmission paths, and between the power supply terminals and transmission terminals
Noise immunity	Power supply normal: 600 V for 10 min with a pulse width of 100 ns to 1 μ s Power supply common: 1.5 kV for 10 min with a pulse width of 100 ns to 1 μ s Coiling around transmission path: 1.5 kV for 10 min with a pulse width of 100 ns to 1 μ s Coiling around Unit: 600 V for 10 min with a pulse width of 100 ns to 1 μ s
Vibration resistance	10 to 55 Hz, 0.75-mm double amplitude for 2 hrs each in X, Y, and Z directions
Shock resistance	Destruction: 300 m/s ² (approx. 30G) Malfunction: 200 m/s ² (approx. 20G)
Ambient temperature	Operating: 0°C to 55°C (32°F to 131°F) Storage: -20°C to 65°C (-4°F to 149°F)
Ambient humidity	Operating: 35% to 85%
Mounting strength	No damage when 5 kgf (49N) pull load was applied for 10 s in all directions
Terminal strength	Tightening strength: 10 kgf • cm (0.98 N • m) for 10 s Pulling strength: 5 kgf (50 N) for 10 s
Weight	4-point model: Approx. 97 g (G730-Y31: approx. 19 g) 8-point/16-point models: Approx. 150 g (G730-Y30: approx. 27 g)
Approvals	UL recognized, File No. E41515; CSA certified, File No. LD31928

Note: The above current consumption is a value with all 4, 8, and 16 points turned ON excluding the current consumption of the external sensor connected to the input Remote Module and the current consumption of the load connected to the output Remote Module.

Nomenclature

■ EIGHT-POINT MODEL

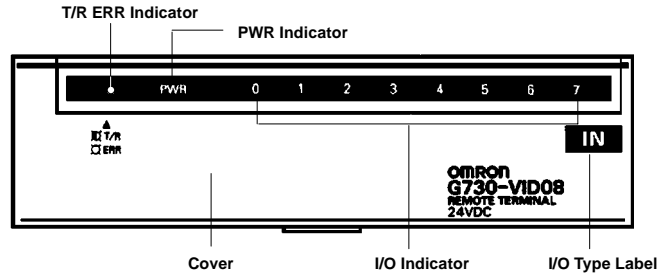

T/R ERR

Display	Function
Flashing	Flashes during normal transmission.
Lit	Lit while the Master Module is waiting for transmission or when a transmission error results.
Not lit	Turns OFF if a CPU error is detected during watchdog timer monitoring.

PWR Indicator

Lit when power is supplied.

I/O Indicator

Indicates the ON and OFF conditions of the I/O of the G730.

Cover

There are DIP switch terminals under the cover as shown in the illustration below.

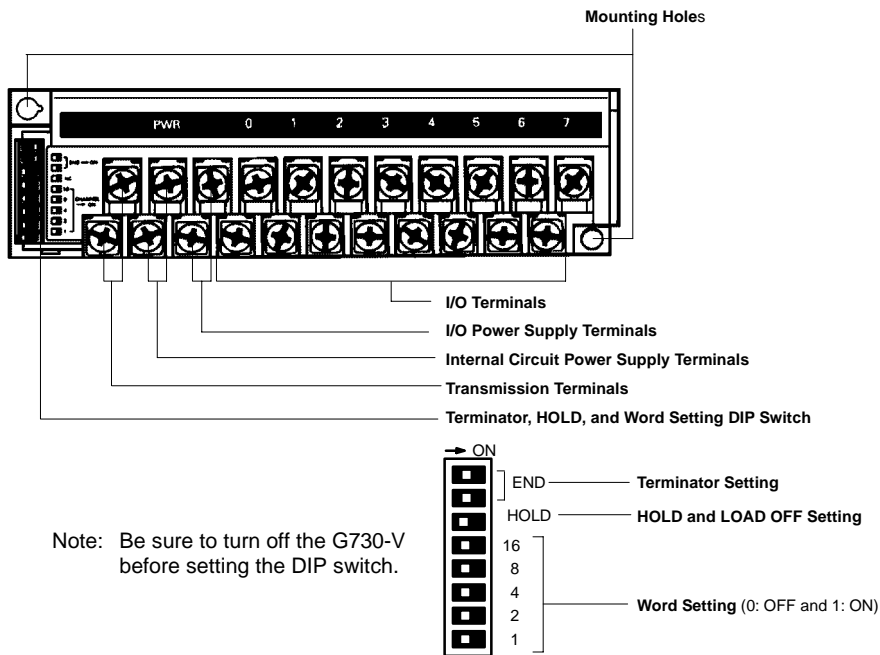

Mounting Hole

Use an M4 screw to mount the DIP switch terminals.

I/O Power Supply Terminals

Connect to a 24 VDC power supply.

Terminator Setting

The pins of the terminator must be set to ON. If these pins of the terminator are set to ON, the terminator resistance of the terminator is turned ON. There must be only one terminator in a system. The G730-V located farthest from the Master on the transmission path must be the terminator. These pins are factory-set to OFF.

Internal Circuit Power Supply Terminals

Connect to a 24 VDC power supply.

Transmission Terminals

Connect a transmission cable.

HOLD and LOAD OFF Setting

HOLD	LOAD OFF
If there is a Slave transmission error during signal transmission, the signal being transmitted is put on hold.	If there is a Slave transmission error during signal transmission, the output of the G730-V is turned OFF.

Note: If the Master has a data error or if there is no data from the Master, a Slave transmission error will result. The HOLD/LOAD OFF selector is factory-set to LOAD OFF.

Word Settings

Word	Switch					Word	Switch				
	1	2	4	8	16		1	2	4	8	16
0	OFF	OFF	OFF	OFF	OFF	16	OFF	OFF	OFF	OFF	ON
1	ON	OFF	OFF	OFF	OFF	17	ON	OFF	OFF	OFF	ON
2	OFF	ON	OFF	OFF	OFF	18	OFF	ON	OFF	OFF	ON
3	ON	ON	OFF	OFF	OFF	19	ON	ON	OFF	OFF	ON
4	OFF	OFF	ON	OFF	OFF	20	OFF	OFF	ON	OFF	ON
5	ON	OFF	ON	OFF	OFF	21	ON	OFF	ON	OFF	ON
6	OFF	ON	ON	OFF	OFF	22	OFF	ON	ON	OFF	ON
7	ON	ON	ON	OFF	OFF	23	ON	ON	ON	OFF	ON
8	OFF	OFF	OFF	ON	OFF	24	OFF	OFF	OFF	ON	ON
9	ON	OFF	OFF	ON	OFF	25	ON	OFF	OFF	ON	ON
10	OFF	ON	OFF	ON	OFF	26	OFF	ON	OFF	ON	ON
11	ON	ON	OFF	ON	OFF	27	ON	ON	OFF	ON	ON
12	OFF	OFF	ON	ON	OFF	28	OFF	OFF	ON	ON	ON
13	ON	OFF	ON	ON	OFF	29	ON	OFF	ON	ON	ON
14	OFF	ON	ON	ON	OFF	30	OFF	ON	ON	ON	ON
15	ON	ON	ON	ON	OFF	31	ON	ON	ON	ON	ON

Note: The word is factory-set to 0.

16-POINT MODEL

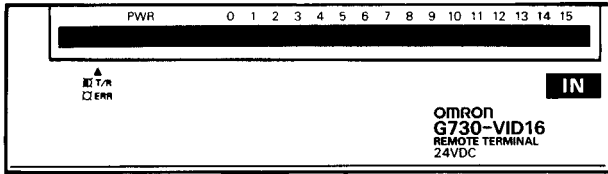

Note: I/O displays and I/O terminals are different from 8-point models. The appearance is otherwise the same as 8-point models. Terminal arrangement and I/O device connection examples are shown at the end of this data sheet.

4-POINT MODEL

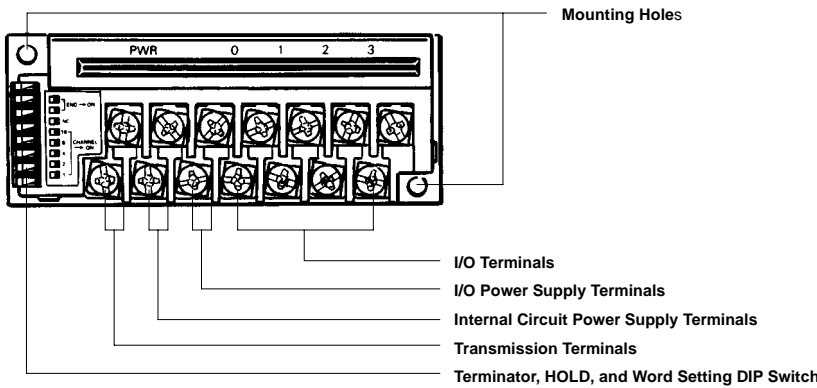

Note: The LED indicators, terminator, HOLD, and word setting methods are the same as for 8-point models.

Mounting Hole

Use an M4 screw to mount the DIP switch terminals.

I/O Power Supply Terminals

Connect to a 24 VDC power supply.

Internal Circuit Power Supply Terminals

Connect to a 24 VDC power supply.

Transmission Terminals

Connect a transmission cable.

Dimensions

Unit: mm (inch)

■ FOUR-POINT MODULES

G730-VID04
G730-VOD04

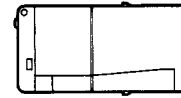
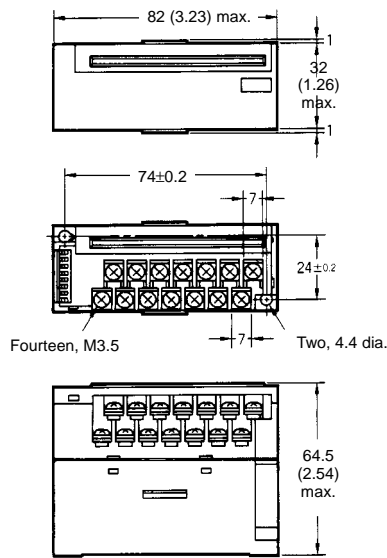
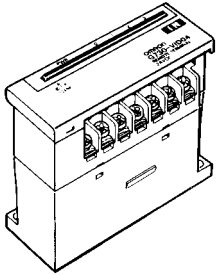

Mounting Holes

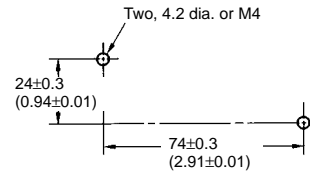

■ DIN TRACK ADAPTER

G730-Y31

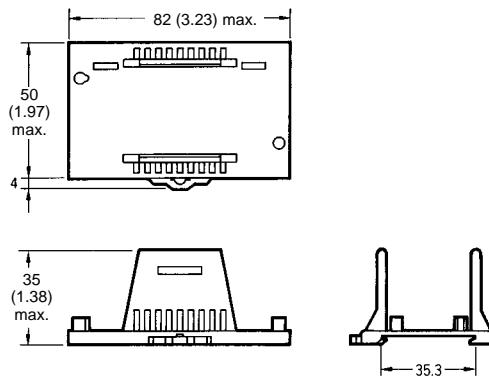
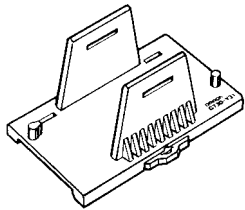

Dimensions with Module Mounted in Adapter

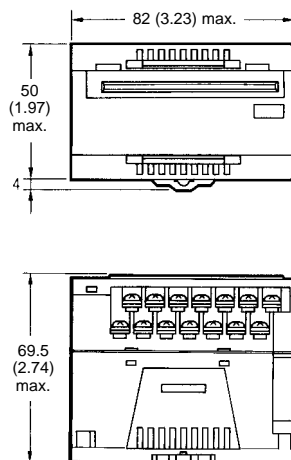
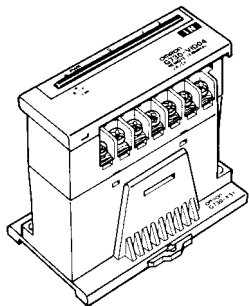

■ 8- AND 16-POINT MODULES

G730-VID08
 G730-VID08-1
 G730-VOD08
 G730-VOD08-1
 G730-VID16
 G730-VOD16

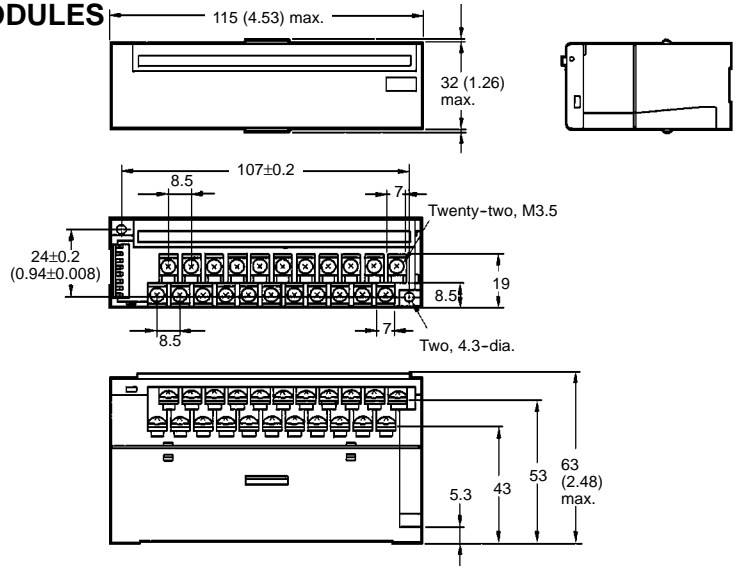
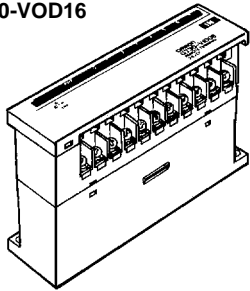

Mounting Holes

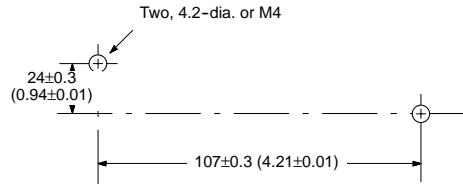

■ DIN TRACK ADAPTER

G730-Y30

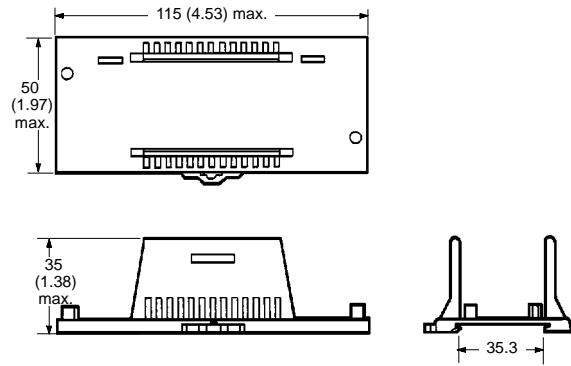
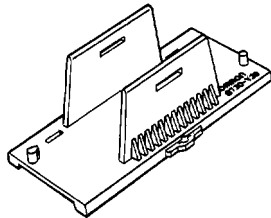

Dimensions with Module Mounted in Adapter

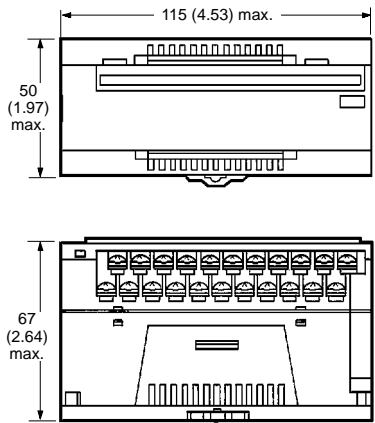
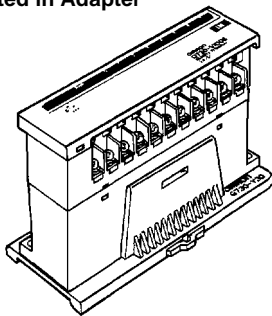

Installation

INTERNAL CIRCUIT CONFIGURATION

**G730-VID04
G730-VID08**

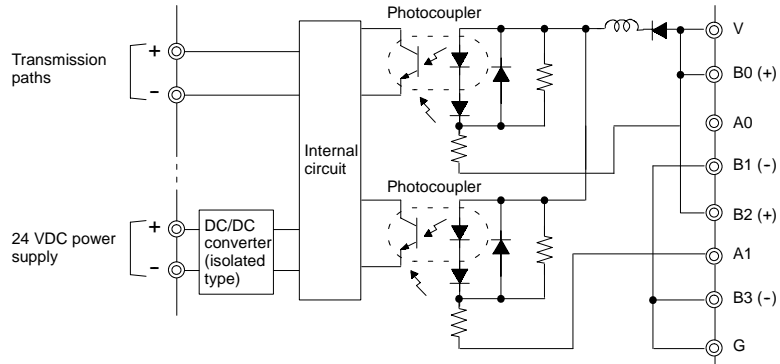

**G730-VOD04
G730-VOD08**

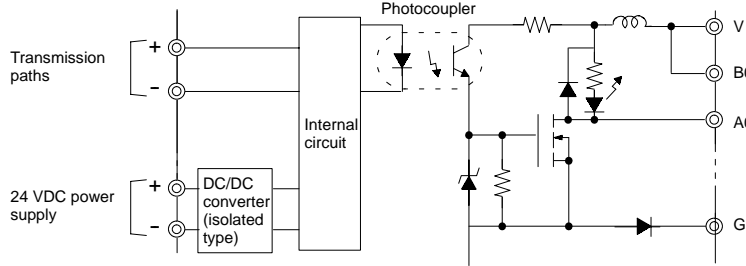

G730-VID08-1

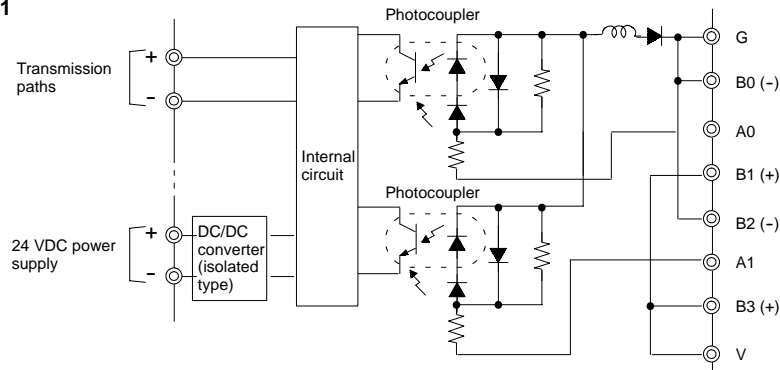

G730-VOD08-1

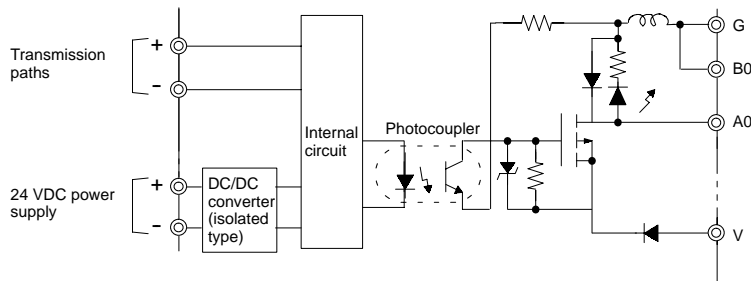

G730-VID16

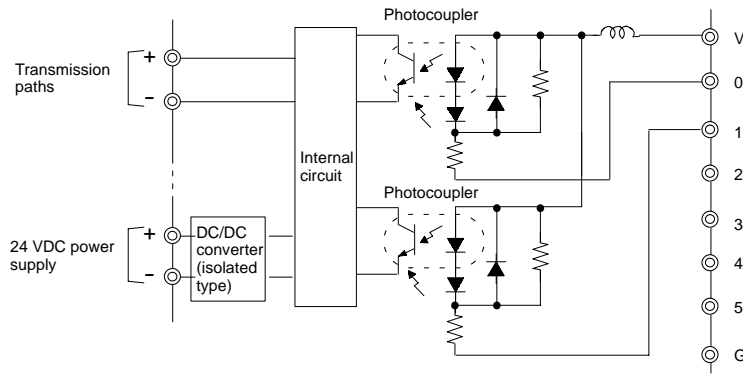

G730-VOD16

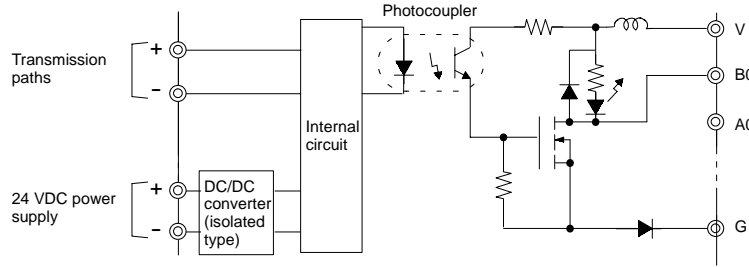

EXTERNAL CONNECTIONS

No relay terminal boards for the sensor loads are required.

**Three-wire System
G730-VID04/G730-VID08 with NPN Output
G730-VID08-1 with PNP Output**

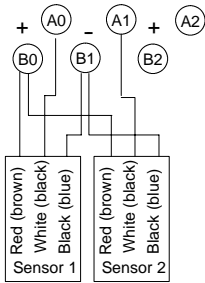

**Two-wire System
G730-VID04/G730-VID08**

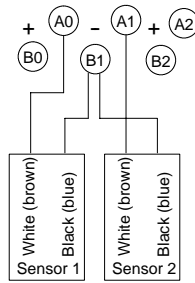

G730-VID08-1

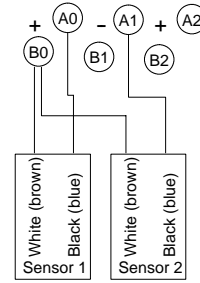

Input Blocks

G730-VID16 with NPN Output

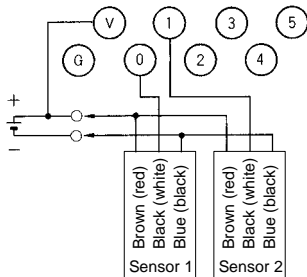

**Two-wire System
G730-VID16**

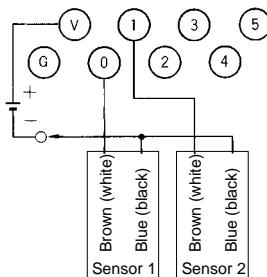

Output Blocks

G730-VOD04/G730-VOD08

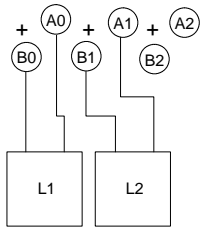

G730-VOD08-1

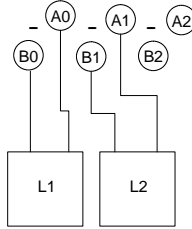

G730-VOD16

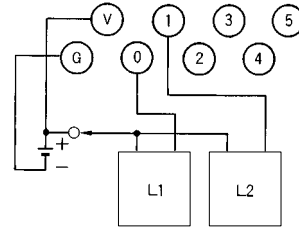

■ TERMINAL ARRANGEMENT AND I/O DEVICE CONNECTION EXAMPLES

Note: 1. The connections examples shown are for NPN models.

2. Wire colors have been changed as a result of changes in JIS standards for photoelectric and proximity sensors. Colors in parentheses are the old colors.

Input Terminals

G730-VID04

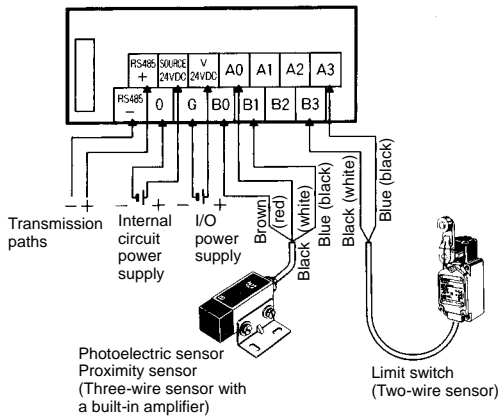

G730-VID08

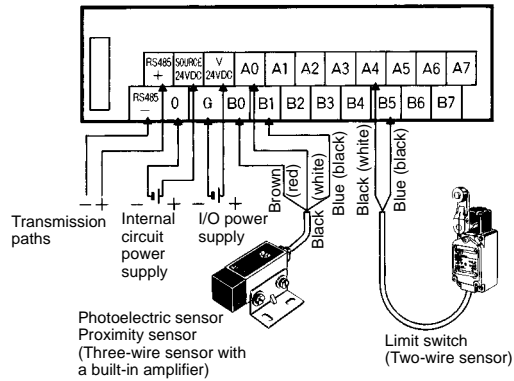

G730-VID16

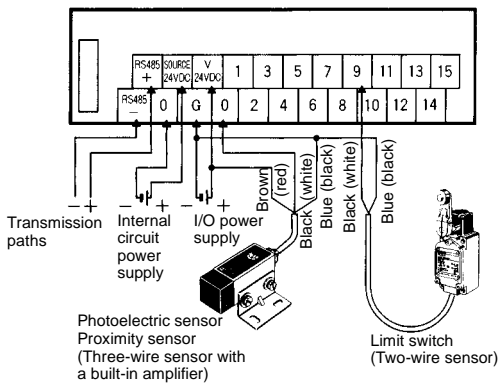

Output Terminals

G730-VOD04

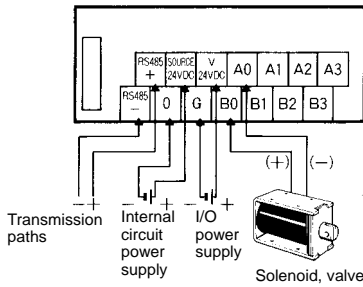

G730-VOD08

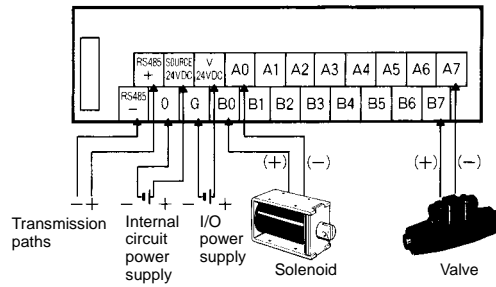

G730-VOD16

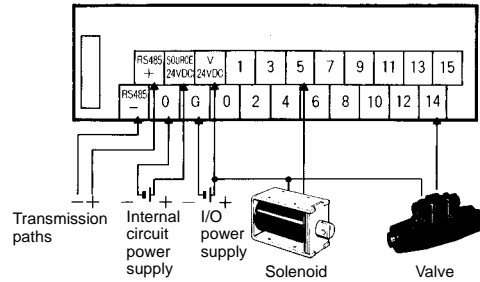

NOTE: DIMENSIONS SHOWN ARE IN MILLIMETERS. To convert millimeters to inches divide by 25.4.

OMRON[®]
OMRON ELECTRONICS, INC.
 One East Commerce Drive
 Schaumburg, IL 60173
1-800-55-OMRON

OMRON CANADA, INC.
 885 Milner Avenue
 Scarborough, Ontario M1B 5V8
416-286-6465