



QUANTA[®]

QXXXXP PROCESS SIGNAL DIGITAL PANEL METER

10288ML-02



This device is marked with the international caution symbol. It is important to read the Setup Guide before installing or commissioning this device as it contains important information relating to safety and EMC

It is the policy of NEWPORT to comply with all worldwide safety and EMC/EMI regulations that apply. NEWPORT is constantly pursuing certification of its products to the European New Approach Directives. NEWPORT will add the CE mark to every appropriate device upon certification.

© Copyright 2000, NEWPORT Electronics, Inc. All rights reserved. This documentation may not be copied, photocopied, reproduced, translated, or reduced to any electronic medium or machine-readable form, in whole or in part, without prior written consent of NEWPORT Electronics, Inc.

Additional products from

NEWPORT Electronics, Inc.

Counters	Rate Meters
Frequency Meters	Timers
PID Controllers	Totalizers
Clock/Timers	Strain Gauge Meters
Printers	Voltmeters
Process Meters	Multimeters
On/Off Controllers	Soldering Iron Testers
Recorders	pH pens
Relative Humidity	pH Controllers
Transmitters	pH Electrodes
Thermocouples	RTDs
Thermistors	Thermowells
Wire	Flow Sensors

For Immediate Assistance
In the U.S.A. and Canada: 1-800-NEWPORT[®]
In Mexico: (95) 800-NEWPORTSM
Or call your local NEWPORT Office.

NEWPORTnetSM On-Line Service
www.newportUS.com

Internet e-mail
info@newportUS.com

It is the policy of NEWPORT to comply with all worldwide safety and EMC/EMI regulations that apply. NEWPORT is constantly pursuing certification of its products to the European New Approach Directives. NEWPORT will add the CE mark to every appropriate device upon certification.

The information contained in this document is believed to be correct but NEWPORT Electronics, Inc. accepts no liability for any errors it contains, and reserves the right to alter specifications without notice.

WARNING: These products are not designed for use in, and should not be used for, patient connected applications.

PATENT NOTICE: This product is covered by one or more of the following patents: U.S. Pat. No. Des. 336,895; 5,274,577 / CANADA 2052599; 2052600 / ITALY 1249456; 1250938 / FRANCE BREVET No. 91 12756 / SPAIN 2039150; 2048066 / UK PATENT No. GB2 249 837; GB2 248 954 / GERMANY DE 41 34398 C2. Other US and International Patents pending or applied for.



This device is marked with the international caution symbol. It is important to read the Setup Guide before installing or commissioning this device as it contains important information relating to safety and EMC.

TABLE OF CONTENTS

SAFETY CONSIDERATIONS	ii
Q2000 MAIN ASSEMBLY	
1.0 Specifications	1
2.0 Mechanical Assembly and Installation	4
3.0 Power & Signal Input Connections	5
4.0 Configuration Procedure	6
5.0 Configuration Charts	7
6.0 Tests and Diagnostics	8
7.0 Main Board Connector Pin Assignments	9
8.0 Drawings	10
Q9000 MAIN ASSEMBLY	
9.0 Specifications	13
10.0 Mechanical Assembly and Installation	16
11.0 Power & Signal Input Connections	17
12.0 Configuration Procedure	18
13.0 Configuration Charts	19
14.0 Tests and Diagnostics	22
15.0 Main Board Connector Pin Assignments	23
16.0 Drawings	24
SIGNAL CONDITIONER BSCR &BSCR/0	
17.0 Specifications	26
18.0 Signal Input Connections	28
19.0 Tests and Diagnostics	29
20.0 Configuration Procedure	30
21.0 Configuration Charts	31
22.0 Calibration	32
23.3 Drawings	33
INSTALLATION INSTRUCTIONS	
24.0 Digital Panel Meter Installation Instructions	34
25.0 Power Requirements and Connections	36

Safety Considerations



This device is marked with the international caution symbol. It is important to read this manual before installing or commissioning this device as it contains important information relating to Safety and EMC (Electromagnetic Compatibility).

Unpacking & Inspection

Note

Unpack the instrument and inspect for obvious shipping damage. Do not attempt to operate the unit if damage is found.

This instrument is a panel mount device protected in accordance with Class I of EN 61010 (115/230 AC power connections). Installation of this instrument should be done by qualified personnel. In order to ensure safe operation, the following instructions should be followed.



This instrument has no power-on switch. An external switch or circuit-breaker shall be included in the building installation as a disconnecting device. It shall be marked to indicate this function, and it shall be in close proximity to the equipment within easy reach of the operator. The switch or circuit-breaker shall not interrupt the Protective Conductor (Earth wire), and it shall meet the relevant requirements of IEC 947-1 and IEC 947-3 (International Electrotechnical Commission). The switch shall not be incorporated in the main supply cord.

Furthermore, to provide protection against excessive energy being drawn from the main supply in case of a fault in the equipment, an overcurrent protection device shall be installed.



Note

- The **Protective Conductor** must be connected for safety reasons. Check that the power cable has the proper Earth wire, and it is properly connected. It is not safe to operate this unit without the Protective Conductor Terminal connected.
- Do not exceed voltage rating on the label located on the top of the instrument housing.
- Always disconnect power before changing signal and power connections.
- Do not use this instrument on a work bench without its case for safety reasons.
- Do not operate this instrument in flammable or explosive atmospheres.
- Do not expose this instrument to rain or moisture.
- Unit mounting should allow for adequate ventilation to ensure instrument does not exceed operating temperature rating.
- Use electrical wires with adequate size to handle mechanical strain and power requirements. Install without exposing bare wire outside the connector to minimize electrical shock hazards.

EMC Considerations

- Whenever EMC is an issue, always use shielded cables.
- Never run signal and power wires in the same conduit.
- Use signal wire connections with twisted-pair cables.
- Install Ferrite Bead(s) on signal wires close to the instrument if EMC problems persist.

Failure to follow all instructions and warnings may result in injury!

1.0 MAIN ASSEMBLY Q2000 SPECIFICATIONS

1.1 GENERAL

The Q2000 main assemblies are identified by an initial designator (BQ2) plus a power/display option numeral, zero thru nine (0-9).

The following table identifies the main assembly types:

Display Type	120 V ac	240 V ac	9-32 V dc	5 V ac	24 V ac
LED	BQ20	BQ22	BQ24	BQ26	BQ28
LCD	BQ21	BQ23	BQ25	BQ27	BQ29

The Digital Panel Meter/Controller consists of a main assembly, signal conditioner and interface options (if ordered) all housed in a 1/8 DIN case.

The main assembly consists of a main board and a display board which is permanently attached to it at a 90 degree angle.

The main board provides mounting for the power supply, circuit components, and connectors for plugging in the signal conditioner, optional analog card, and optional controller/communications interface card (requires removal of a bypass push-on jumper).

The display board includes the analog-to-digital converter, the LED or LCD display and the push-on jumper for programming the decimal points. Decimal point programming may also be done from the main board connector (J1).

1.2	POWER	
	AC Models:	24/120/240V +10/-15% 47-63 Hz
	Common Mode Voltage:	1500 Vp test (354 Vp per IEC spacing)
	DC Models:	5V \pm 5% (5V return common to signal LO) 9-32V (300V isolation from 9-32V return to signal LO)
	Source Impedance:	3 Ohms
	Ripple:	250 mV maximum
	Power Consumption:	5 watts maximum
1.3	DISPLAY	
	LED:	14.2mm (0.56 in), 7-segment light emitting diode
	Lens Color:	Red
	LCD:	12.7 mm (0.50 in), 7-segment liquid crystal
	Lens color:	Clear
	Range:	0 to \pm 1999
	Overload Indication:	Three least significant digits blanked, "1" or "-1" displayed
1.4	CONVERSION	
	Technique:	Auto-zero, dual slope, average value
	Signal Integration Period:	100ms, nominal
	Reading Rate:	2.5/s, nominal
1.5	ENVIRONMENTAL	
	Operating Temperature (Ambient):	0-60 °C
	Storage Temperature:	-40 to 85 °C
	Humidity:	To 95% RH, non-condensing, 0-40 °C
1.6	MECHANICAL	
	Case Material:	UL-rated 94V-0, polycarbonate
	Weight:	0.57 kg (with interface board)

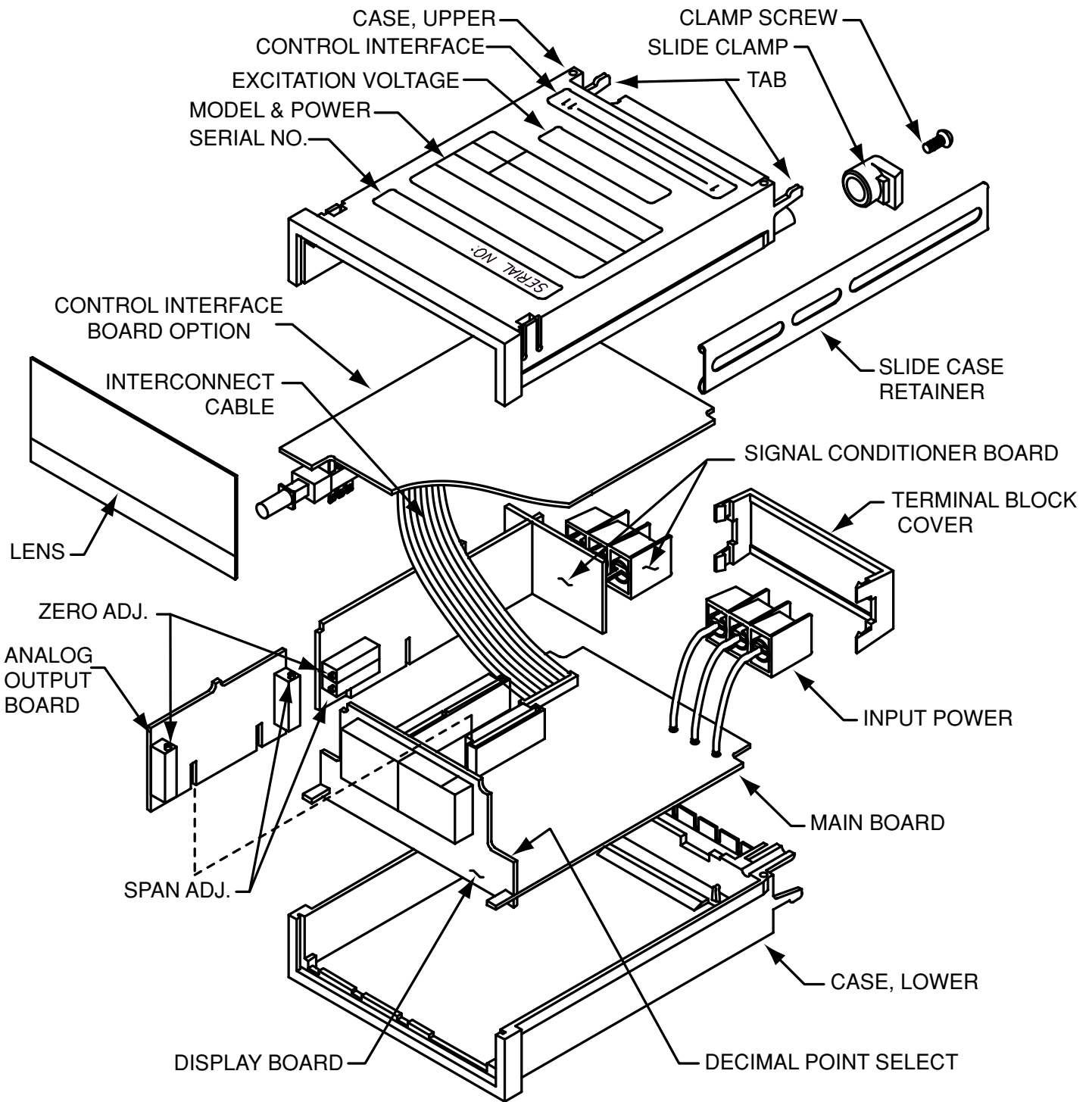

2.0 MECHANICAL ASSEMBLY & INSTALLATION

2.1 PANEL MOUNTING PROCEDURE (SEE FIGURE 1)

1. Remove the main board edge connector (J1), if installed.
2. Remove the interface board connector (J2), if installed.
3. Loosen two clamp screws on the rear of the case enough to rotate the two slide clamps.
4. Slide the two slide retainers toward the rear of the case and remove them.
5. From the front of the panel, insert the meter into the panel cutout.
6. Slide the slide retainers back onto the case and push up tightly against the rear of the panel.
7. Rotate the slide clamps back into their original position and tighten enough to hold the case in place. Overtightening can break the clamps.
8. Install any connectors removed.

2.2 LABELS (SEE FIGURE 2)

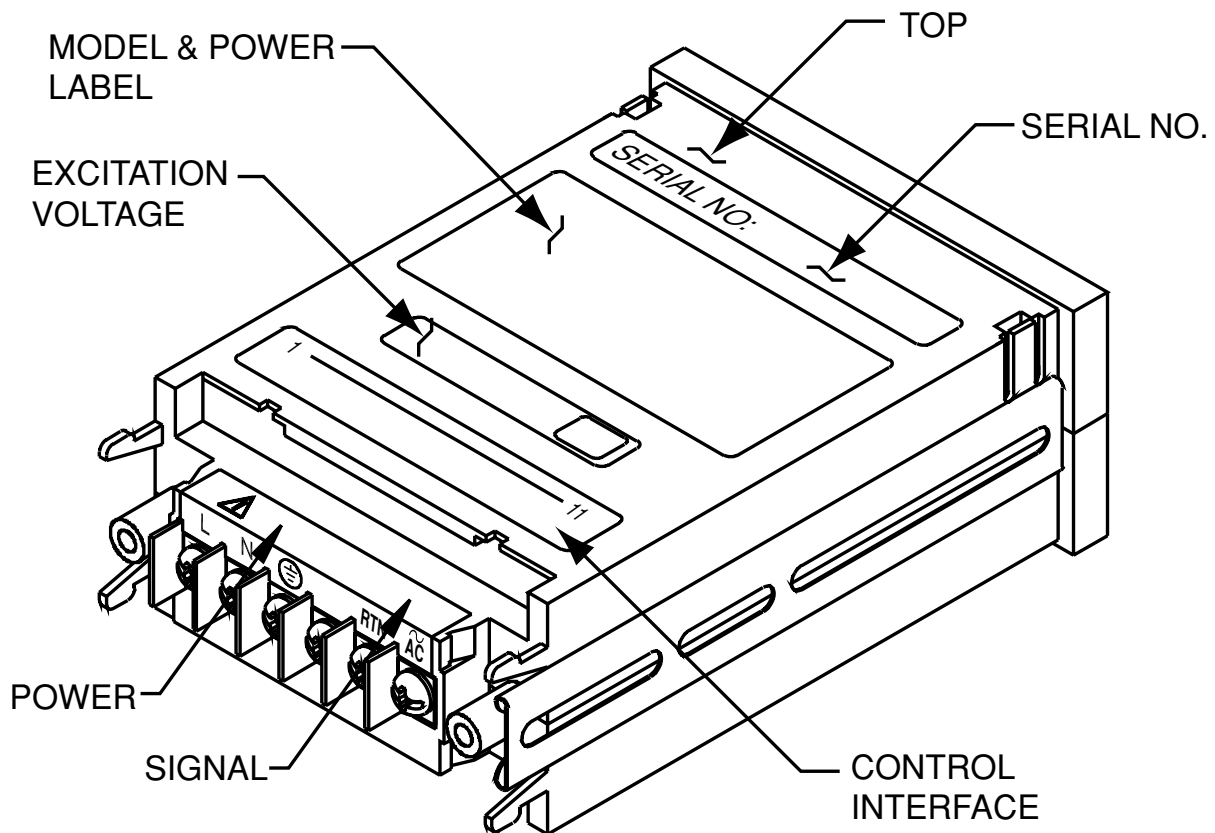

NOTE: READ LABELS FROM THE REAR

FIGURE 2. LABEL PLACEMENT

3.0 POWER & SIGNAL INPUT CONNECTIONS

WARNING: Incorrect power input can damage your PANEL METER.

3.1 POWER CONNECTIONS

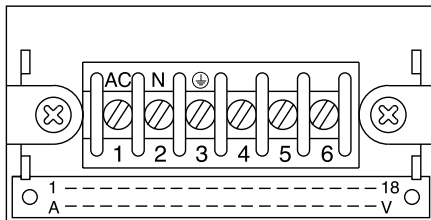

REAR TERMINAL VIEW

Terminal Connection	AC Versions	Wire Color
1	AC power HI	Black
2	AC power LO (neutral)	White
3	AC power GND	Green

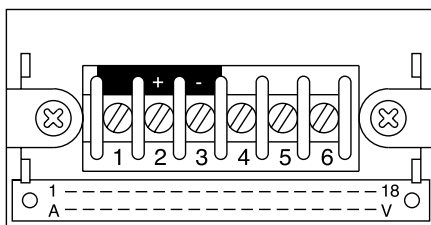

REAR TERMINAL VIEW

Terminal Connection	DC Versions
1	No connection
2	DC power +
3	DC power - (return)

3.2 SIGNAL INPUT CONNECTIONS

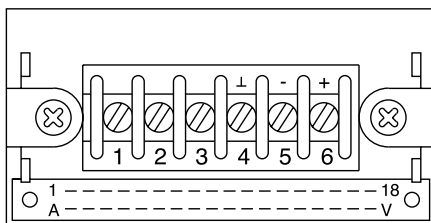

REAR TERMINAL VIEW

Terminal Connection	6 Terminal Versions Signal
4	Analog GND
5	Signal LO
6	Signal HI

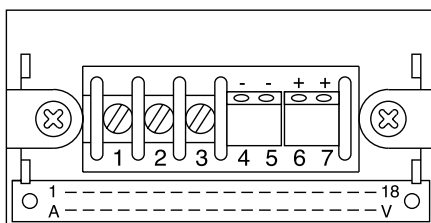

REAR TERMINAL VIEW

Terminal Connection	7 Terminal Versions Signal
4	-E (Excitation return)
5	-S (Signal LO input)
6	+S (Signal HI input)
7	+E (Excitation output)

4.0 CONFIGURATION PROCEDURE

This procedure is used to set the decimal point of the display and interface board signal bypass selections for the configuration of the Q2XXX Display and power options (BQ20 through BQ29).

The main assembly can be configured using the push-on jumpers provided or already positioned on the pin forests. Pin forest designations are shown at the top of every page of the configuration charts.

5.0 CONFIGURATION CHARTS

5.1 DECIMAL POINT SELECTION

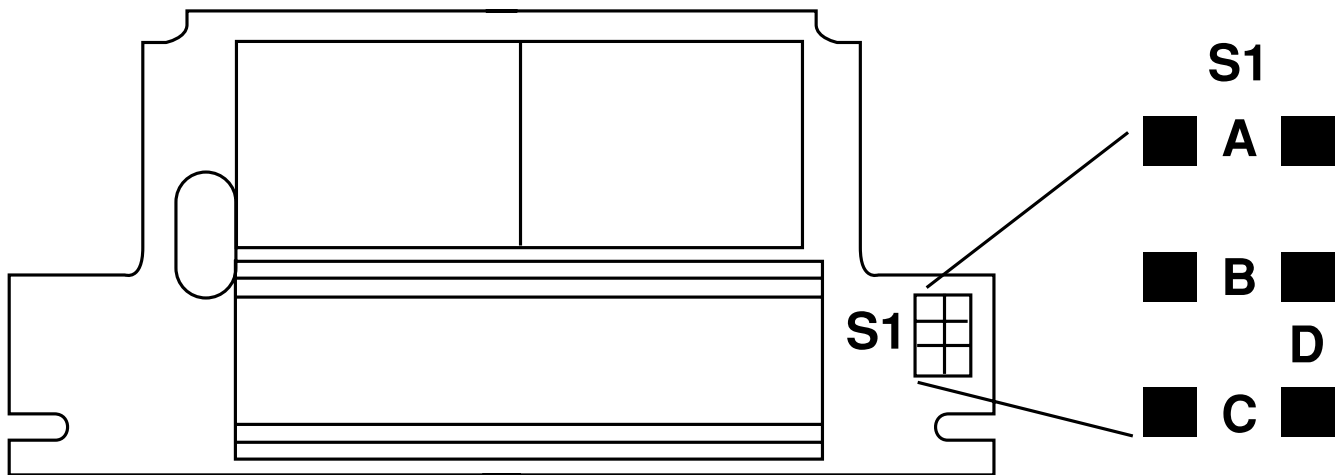

Step 1:		Remove all push-on jumpers not used in the desired configuration(s).
Step 2:		Select the desired configuration from the chart below, then install the push-on jumpers indicated.
Decimal Point Selection	S1	Alternate Decimal Point Selection Using Main Assembly Board (J1) Connector
Decimal Point (1.999)	A	Connect J1-K/9 to J1-6
Decimal Point (19.99)	B	Connect J1-J/8 to J1-6
Decimal Point (199.9)	C	Connect J1-H/7 to J1-6
No Decimal Point (1999)	D	No Connection

5.2 INTERFACE BOARD SIGNAL BYPASS SELECTION

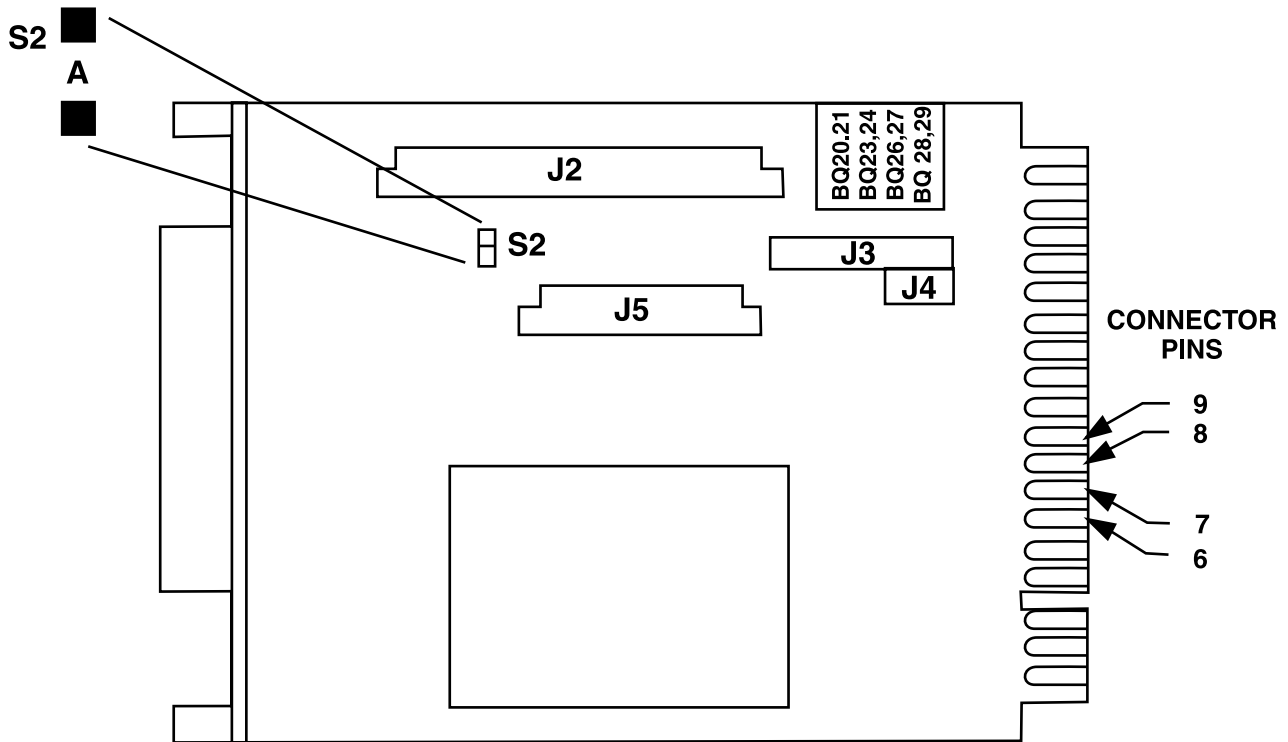

Step 1:	Check your Quanta part number for a zero (0) in the following position: Q2XX0X. If there is a zero (0) in that position, interface board signal bypass is required.
Step 2:	Remove all push-on jumpers not used in the desired configuration(s).
Step 3:	Select the desired configuration from the chart below, then install the push-on jumpers indicated.
Interface Board Signal Configuration	S2
Interface Board Signal Bypass	A

6.0 TESTS & DIAGNOSTICS

6.1 TEST CONFIGURATION REQUIREMENTS

The main assembly is designed to function with a signal conditioner board as a minimum configuration. There is no provision for testing a main assembly alone.

6.2 SIGNAL INPUT REQUIREMENTS

Signal input requirements for your configuration are identified in the signal conditioner section of this manual.

7.0 Main Board Connector Pinouts (J1)

(Left to right, looking at rear of case)

<u>Connection</u>	<u>Function</u>	
A-1	Spare	
B	Oscillator	40 kHz
2	-8.2 V dc	Analog power
C-3	Spare	
D	+ Pol (sign)	+ Polarity sign
4	$\overline{\text{HOLD}}$	LED Version Only
E-5	Spare	
F	Buffer	Integrator output
6	Digital Ground	
H-7	199.9 (Decimal Point)	Use with pin 6
J-8	19.99 (Decimal Point)	Use with pin 6
K-9	1.999 (Decimal Point)	Use with pin 6
L-10	Test (LED version only)	Use with pin M/11
M-11	+5 V dc	Analog and Digital Power
N-12	Analog output	Standard 1 mV/count
P-13	Spare	
R-14	Spare	Used with H & S options -Excitation sense
S-15	Analog Ground	
T-16	Analog Option - Return	Used with analog option
U	Analog Option - Out	Used with analog Option
17	+30 V dc	Unregulated power
V-18	Spare	Used with S option +Excitation sense
-	Indicates common pin. 50 mA maximum power available from all internal sources.	

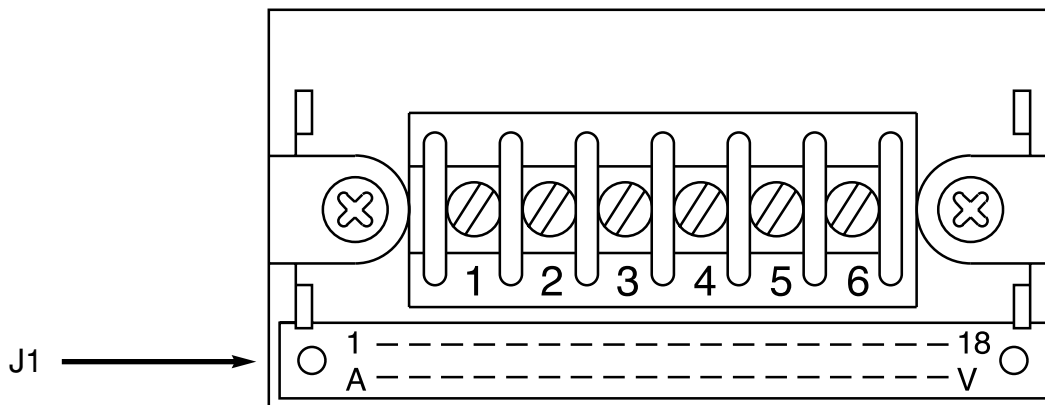

REAR TERMINAL VIEW

8.0 DRAWINGS

8.1 DIMENSIONS

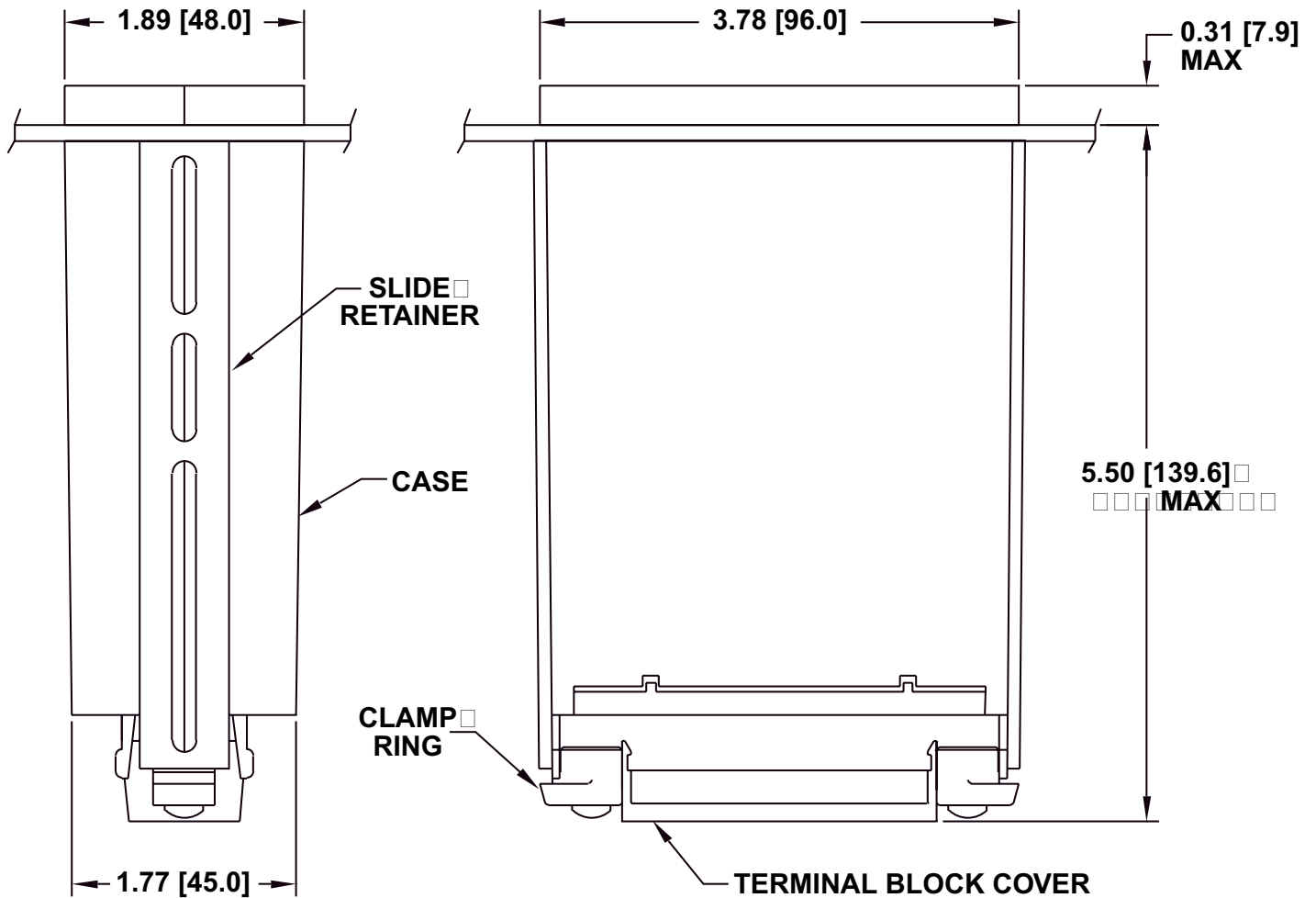

Notes: Dimensions are in inches ± 0.01 with millimeters in [] ± 0.25 mm.

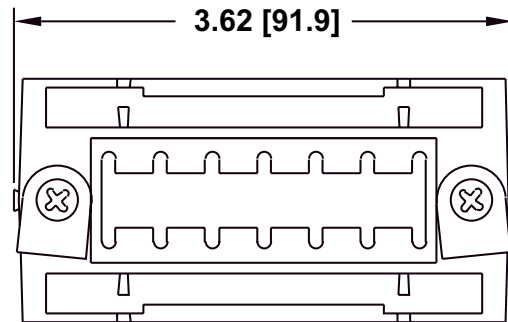
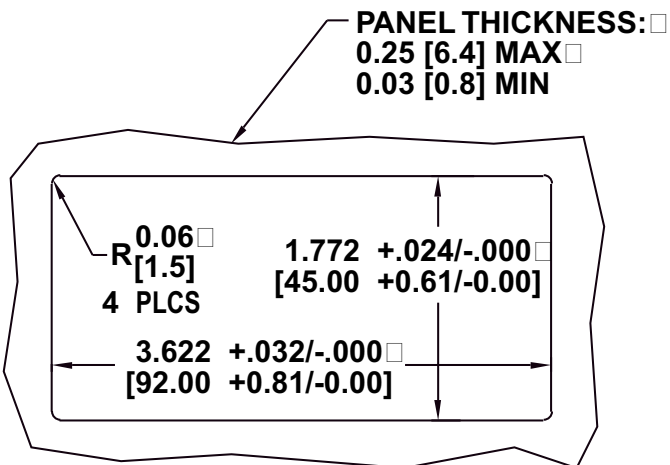

Terminal block cover and bezel not shown for clarity. Clamp rings rotated and slide retainers removed as shown for installation.

8.2 Q2000 MAIN ASSEMBLY LED

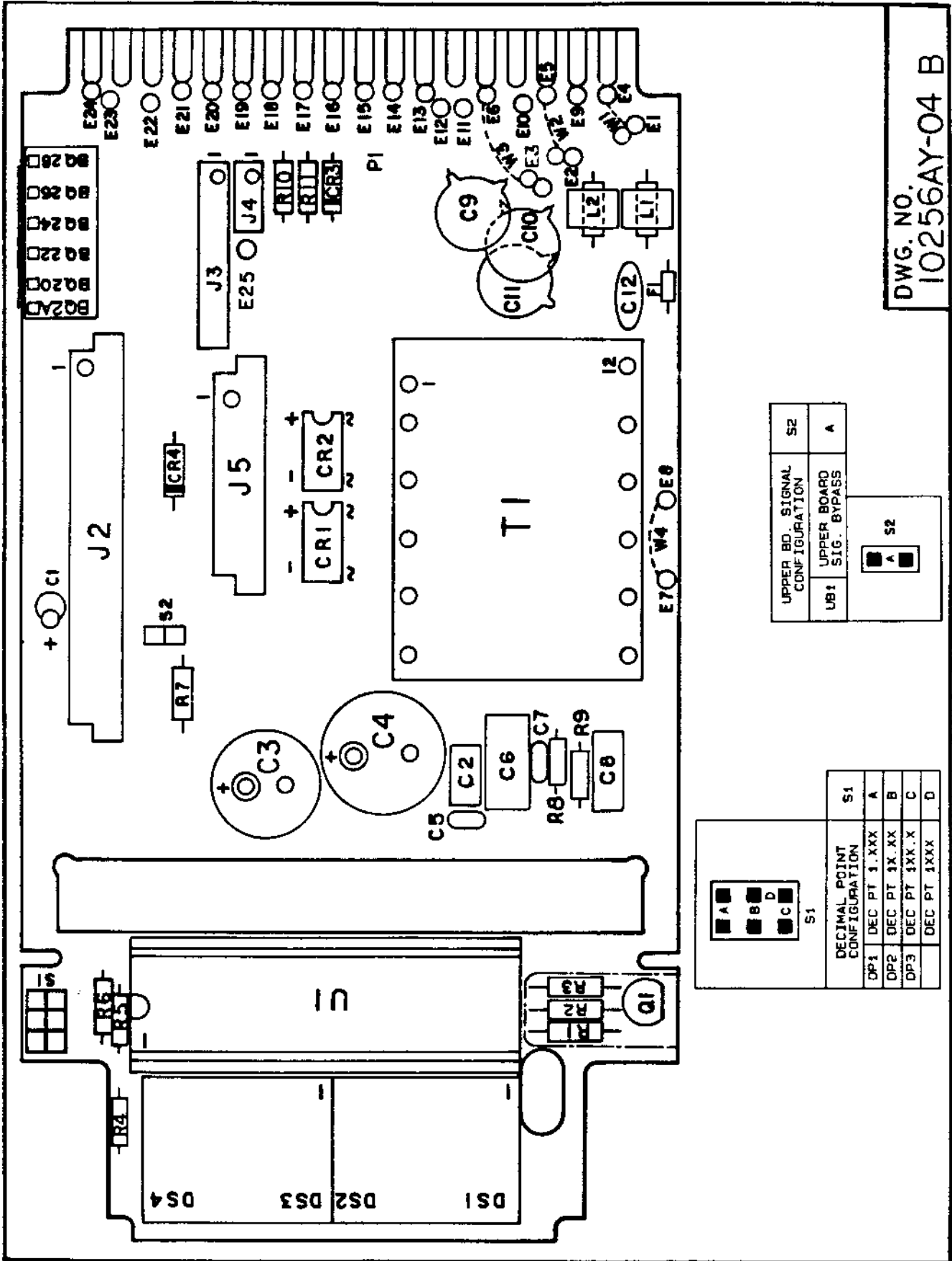

DWG. NO.
10256AY-04 B

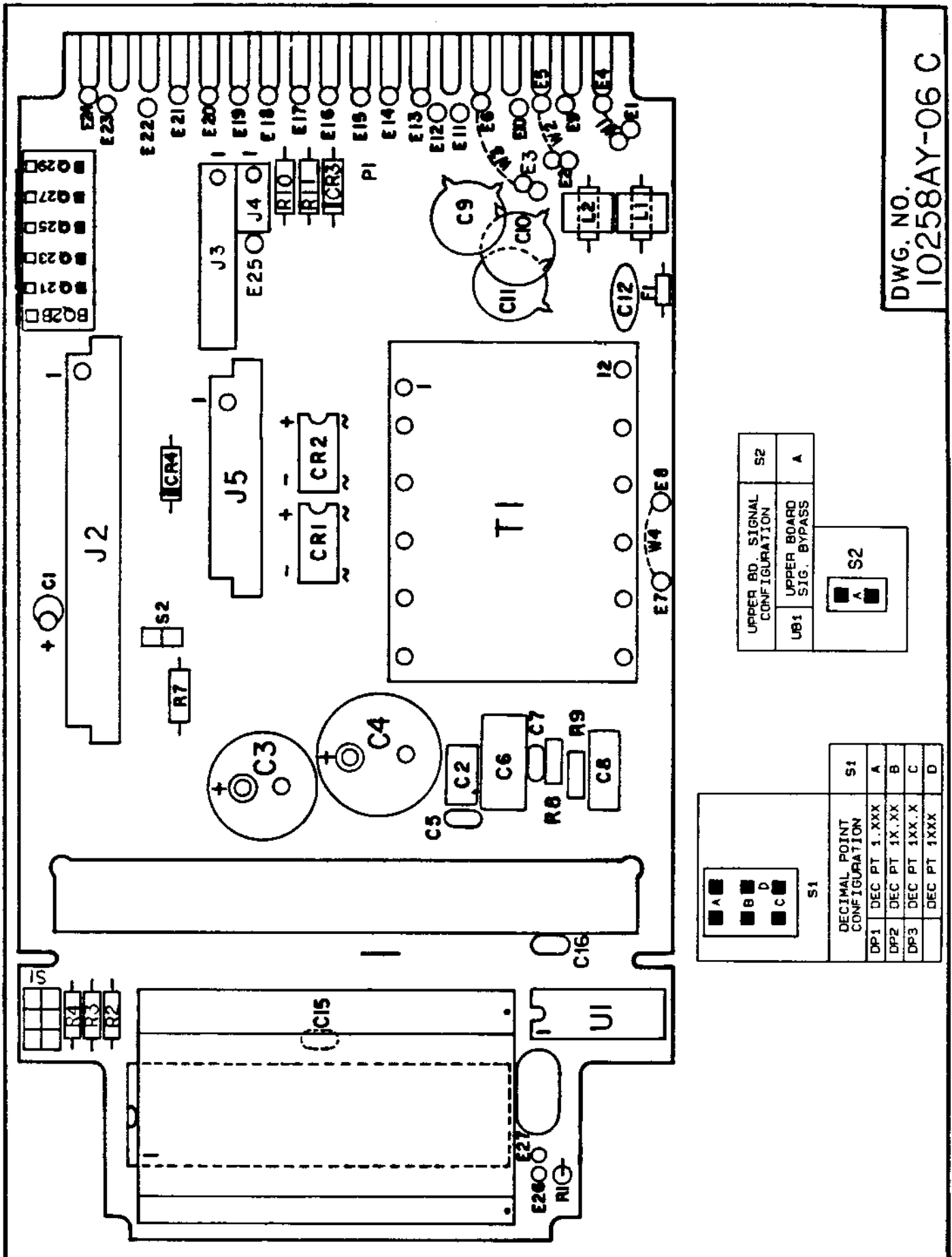

DWG. NO.
10258AY-06 C

9.0 MAIN ASSEMBLY Q9000 SPECIFICATIONS

9.1 GENERAL

Q9000 main assemblies are identified by an initial designator (BQ9) plus a power/display option numeral: 0, 2, 4, 6 or 8.

The following table identifies the main assembly types:

Display Type	120 V ac	240 V ac	9-32 V dc	5 V ac	24 V ac
LED	BQ90	BQ92	BQ94	BQ96	BQ98

The QUANTA Digital Panel Meter/Controller consists of a main assembly, signal conditioner and interface options (if ordered) all housed in a 1/8 DIN case.

The main assembly consists of a main board and a display board which is permanently attached to it at a 90 degree angle.

The main board provides mounting for the power supply, circuit components, and connectors for plugging in the signal conditioner, optional analog card, and optional controller/communications interface card (requires removal of a bypass push-on jumper).

The display board includes the analog-to-digital converter, the LED display and the push-on jumper for programming the decimal points. Decimal point programming may also be done from the main board connector (J1).

9.2	POWER	
	AC Models:	24/120/240V +10/-15% 47-63 Hz
	Common Mode Voltage:	1500 Vp test (354 Vp per IEC spacing)
	DC Models:	5V \pm 5% (5V return common to signal LO)
		9-32V (300V isolation from 9-32V return to signal LO)
	Source Impedance:	3 Ohms
	Ripple:	250mV maximum
	Power Consumption:	5 watts maximum
9.3	DISPLAY	
	LED:	14.2mm (0.56 in), 7-segment light emitting diode
	Lens Color:	Red
	Range:	0 to \pm 9999, digits flash from 10K-20K counts
	Overload Indication:	Four digits flash zeros at 20K and above
9.4	CONVERSION	
	Technique:	Auto-zero, dual slope, average value
	Signal Integration Period:	100ms, nominal
	Reading Rate:	2.5/s, nominal
9.5	ENVIRONMENTAL	
	Operating Temperature (Ambient):	0-60 °C
	Storage Temp.:	-40 to 85 °C
	Humidity:	To 95% RH, non-condensing, 0-40 °C
9.6	MECHANICAL	
	Case Material:	UL-rated 94V-0, polycarbonate
	Weight:	0.57 kg (with interface board)

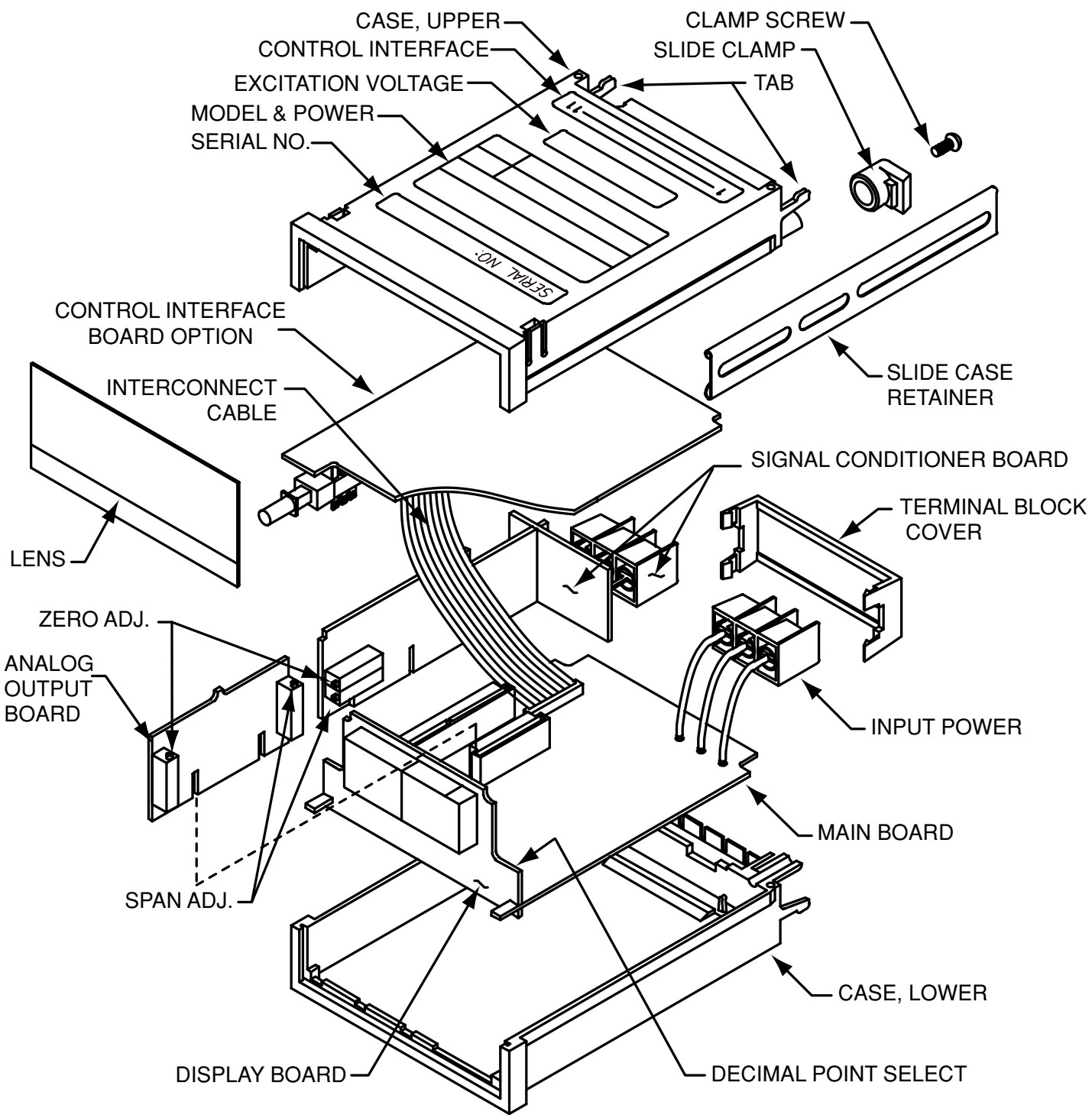

10.0 MECHANICAL ASSEMBLY & INSTALLATION

10.1 PANEL MOUNTING PROCEDURE (SEE FIGURE 3)

1. Remove the main board edge connector (J1), if installed.
2. Remove the interface board connector (J2), if installed.
3. Loosen two clamp screws on the rear of the case enough to rotate the two slide clamps.
4. Slide the two slide retainers toward the rear of the case and remove them.
5. From the front of the panel, insert the meter into the panel cutout.
6. Slide the slide retainers back onto the case and push up tightly against the rear of the panel.
7. Rotate the slide clamps back into their original position and tighten enough to hold the case in place. Overtightening can break the clamps.
8. Install any connectors removed.

10.2 LABELS (SEE FIGURE 4)

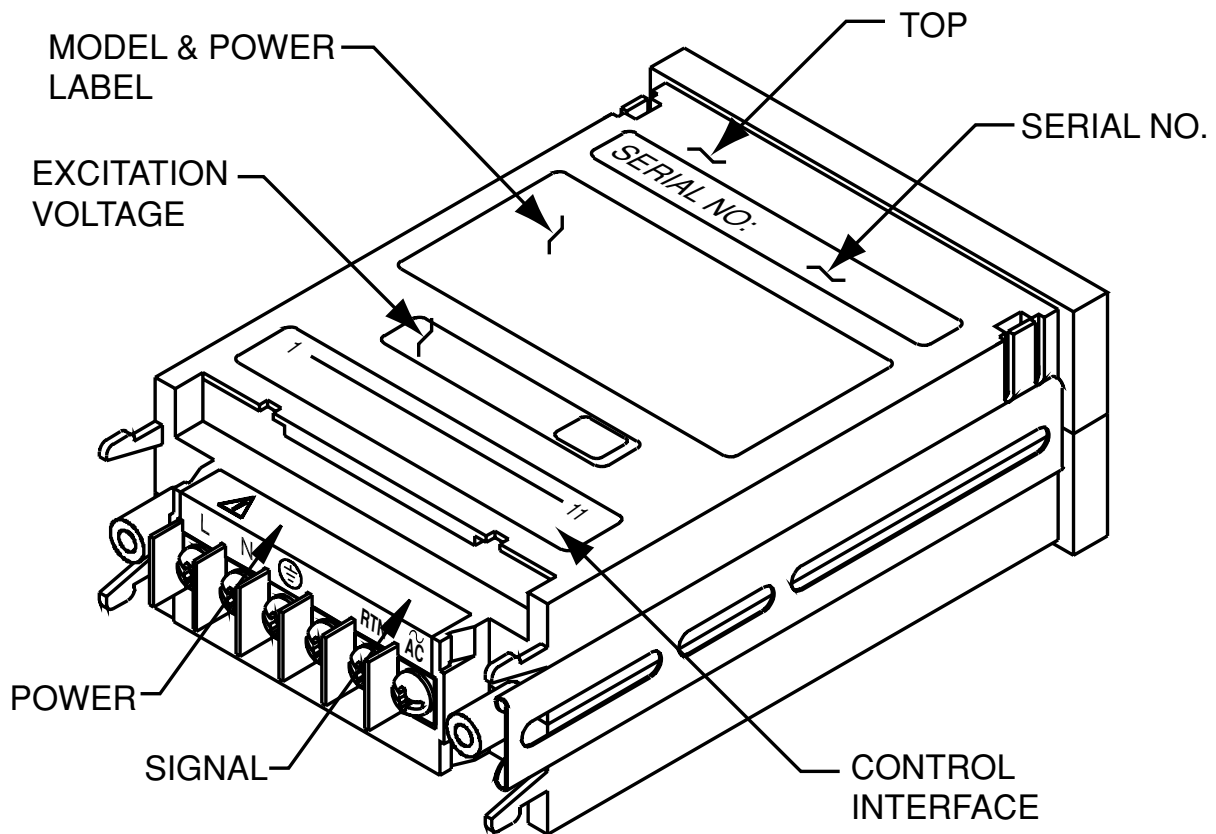

NOTE: READ LABELS FROM THE REAR

FIGURE 4. LABEL PLACEMENT

11.0 POWER & SIGNAL INPUT CONNECTIONS

WARNING: Incorrect power input can damage your PANEL METER.

11.1 POWER CONNECTIONS

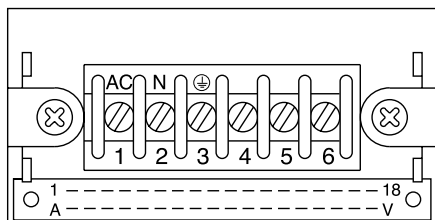

REAR TERMINAL VIEW

Terminal Connection	AC Versions	Wire Color
1	AC power HI	Black
2	AC power LO (neutral)	White
3	AC power GND	Green

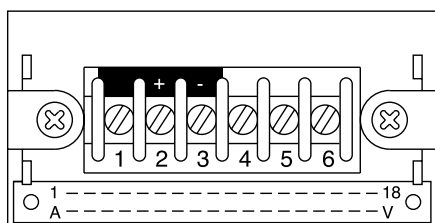

Terminal Connection	DC Versions
1	No connection
2	DC power +
3	DC power - (return)

11.2 SIGNAL INPUT CONNECTIONS

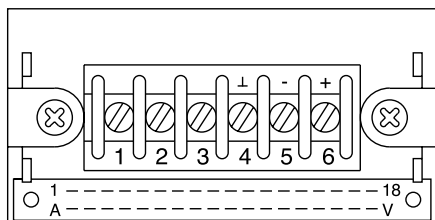

REAR TERMINAL VIEW

Terminal Connection	6 Terminal Versions Signal
4	Analog GND
5	Signal LO
6	Signal HI

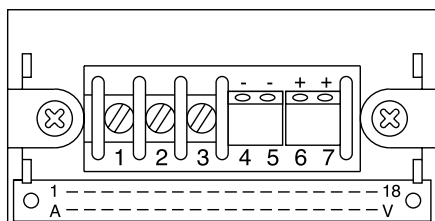

Terminal Connection	7 Terminal Versions Signal
4	-E (Excitation return)
5	-S (Signal LO input)
6	+S (Signal HI input)
7	+E (Excitation output)

12.0 CONFIGURATION PROCEDURE

This procedure is used to set the decimal point of the display and interface board signal bypass selections for the configuration of the Q9XXX display and power options (BQ90 through BQ98).

The main assembly can be configured using the push-on jumpers provided or already positioned on the pin forests. Pin forest designations are shown at the top of every page of the configuration charts.

13.0 CONFIGURATION CHARTS

13.1 DECIMAL POINT SELECTION

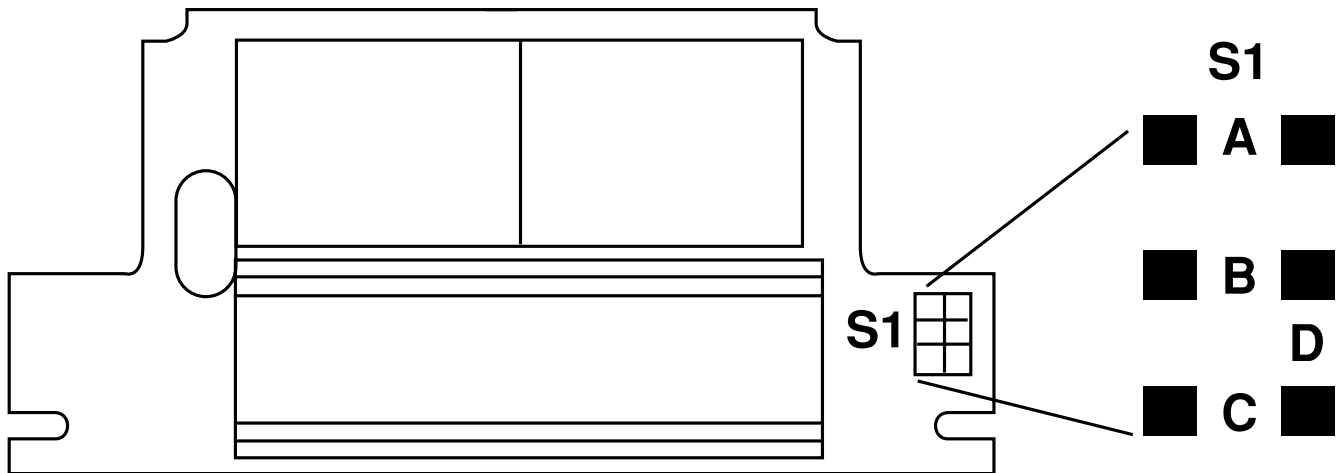

Step 1:	Remove all push-on jumpers not used in the desired configuration(s).	
Step 2:	Select the desired configuration from the chart below, then install the push-on jumpers indicated.	
Decimal Point Selection	S1	Alternate Decimal Point Selection Using Main Assembly Board (J1) Connector
Decimal Point (9.999)	A	Connect J1-K/9 to J1-6
Decimal Point (99.99)	B	Connect J1-J/8 to J1-6
Decimal Point (999.9)	C	Connect J1-H/7 to J1-6
No Decimal Point (9999)	D	No Connection

13.2 INTERFACE BOARD SIGNAL BYPASS SELECTION

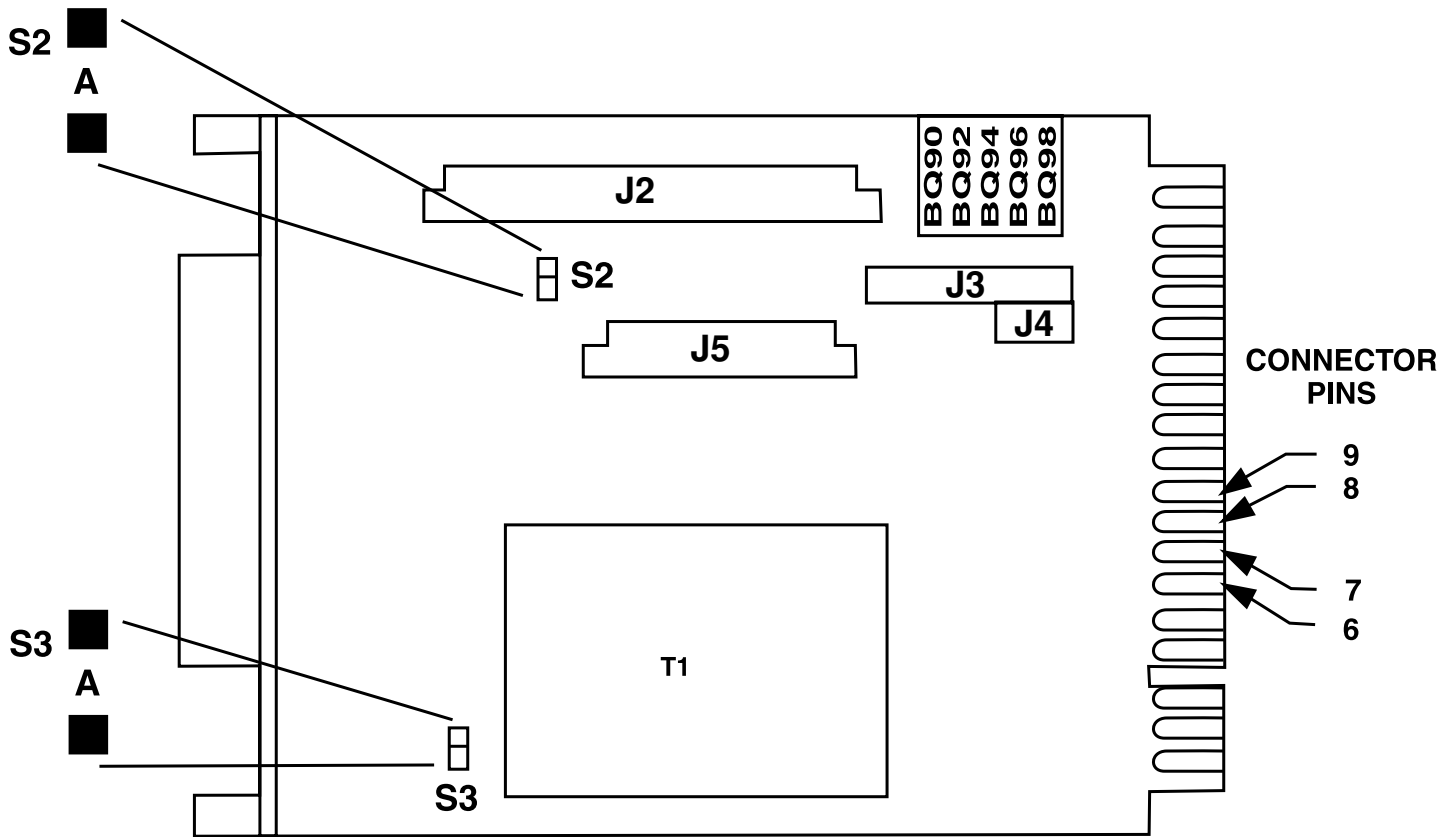

Step 1: Check your Quanta part number for a zero (0) in the following position: Q9XX0X. If there is a zero (0) in that position, interface board signal bypass is required.	
Step 2: Remove all push-on jumpers not used in the desired configuration(s).	
Step 3: Select the desired configuration from the chart below, then install the push-on jumpers indicated.	
Interface Board Signal Configuration	S2
Interface Board Signal Bypass	A

13.3 REFERENCE VOLTAGE (RV1, RV2)

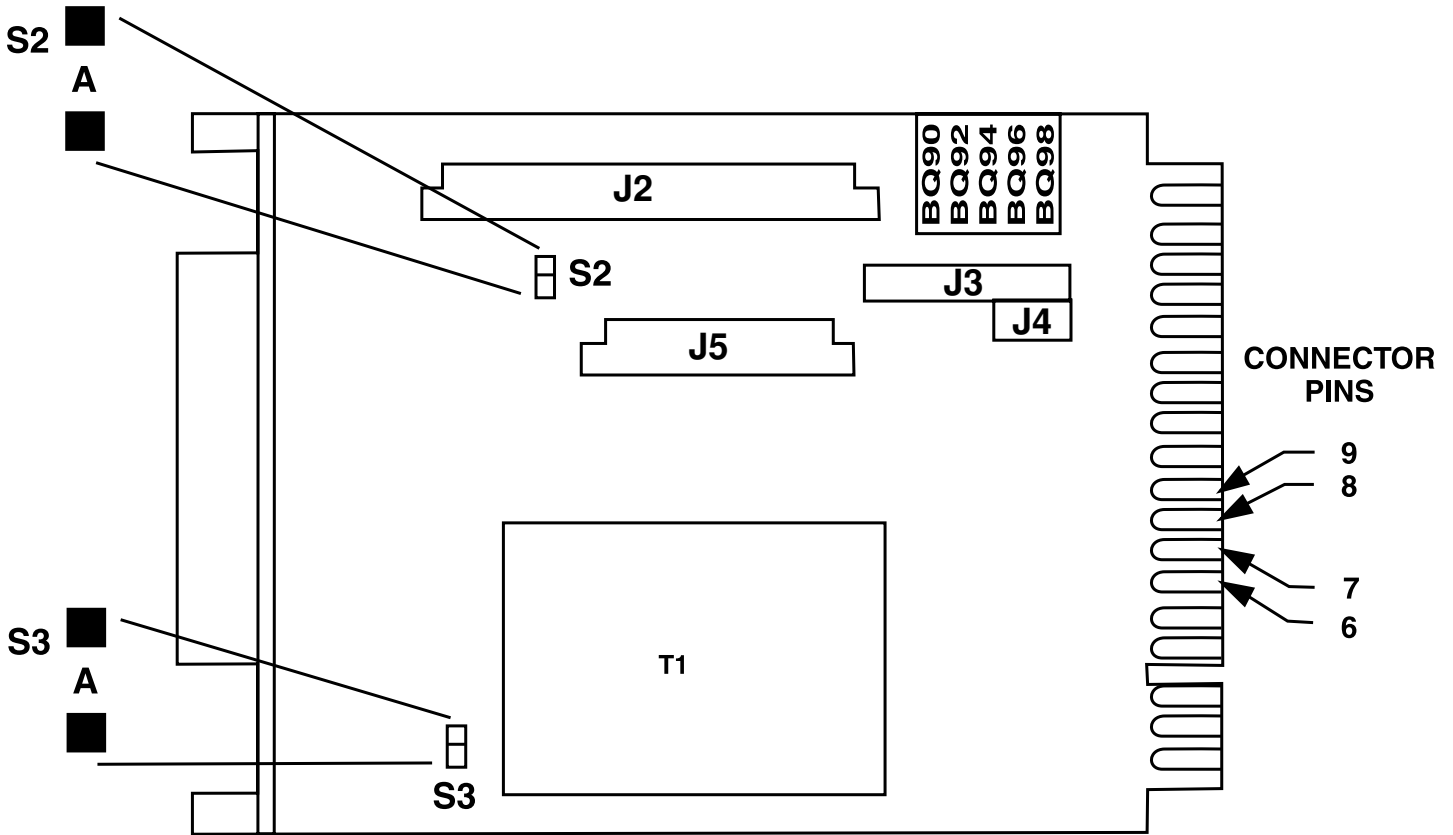

Step 1: Remove all push-on jumpers not used in the desired configuration(s).		
Step 2: Select the desired configuration from the chart below, then install the push-on jumpers indicated.		
Reference Voltage Configuration		S3
RV1	1 Volt	A
RV2	2 Volts	-

14.0 TESTS & DIAGNOSTICS

14.1 TEST CONFIGURATION REQUIREMENTS

The main assembly is designed to function with a signal conditioner board as a minimum configuration. There is no provision for testing a main assembly alone.

14.2 SIGNAL INPUT REQUIREMENTS

Signal input requirements for your configuration are identified in the signal conditioner section of this manual.

15.0 MAIN BOARD CONNECTOR PINOUTS (J1)

(Left to right, looking at rear of case)

<u>Connection</u>	<u>Function</u>	
A - 1	Spare	
B	Oscillator	100 kHz
2	-8.2 V dc	Analog power
C - 3	Spare	
D	+ Pol (sign)	+ Polarity sign
4	Hold	LED version only
E - 5	Spare	
F	Buffer	Integrator output
6	Digital Ground	
H - 7	XXX.X (Decimal Point)	Use with pin 6
J - 8	XX.XX (Decimal Point)	Use with pin 6
K - 9	X.XXX (Decimal Point)	Use with pin 6
L - 10	TEST	Use with pin M/11
M - 11	+5 V dc	Analog & digital power
N - 12	Analog output	Standard 1 mV/count
P 13	Spare	
R	Spare	
14	Used with H & S options - Excitation sense	
S - 15	Analog Ground	
T - 16	Analog Option - Return	Used with analog option
U	Analog Option - Out	Used with analog option
17	+30 V dc	Unregulated power
V - 18	Spare	Used with S option
-	+ Excitation sense	
-	Indicates common pin.	
	50 mA maximum power available from all internal sources.	

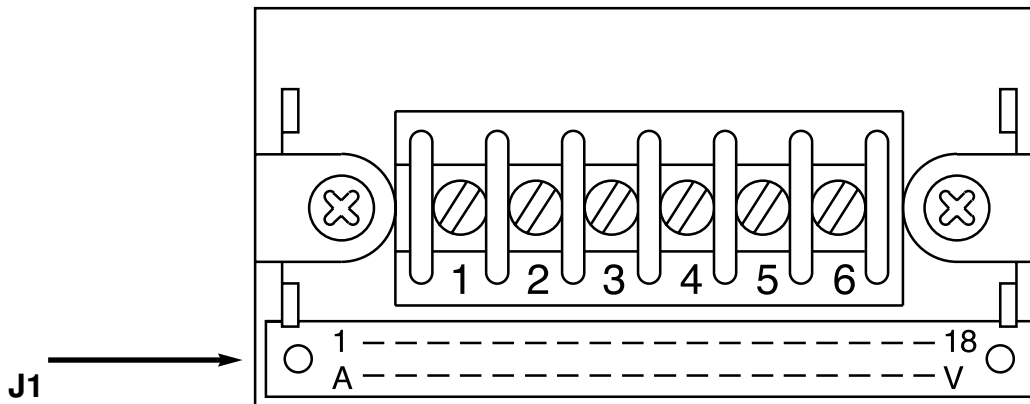

REAR TERMINAL VIEW

16.0 DRAWINGS

16.1 DIMENSIONS

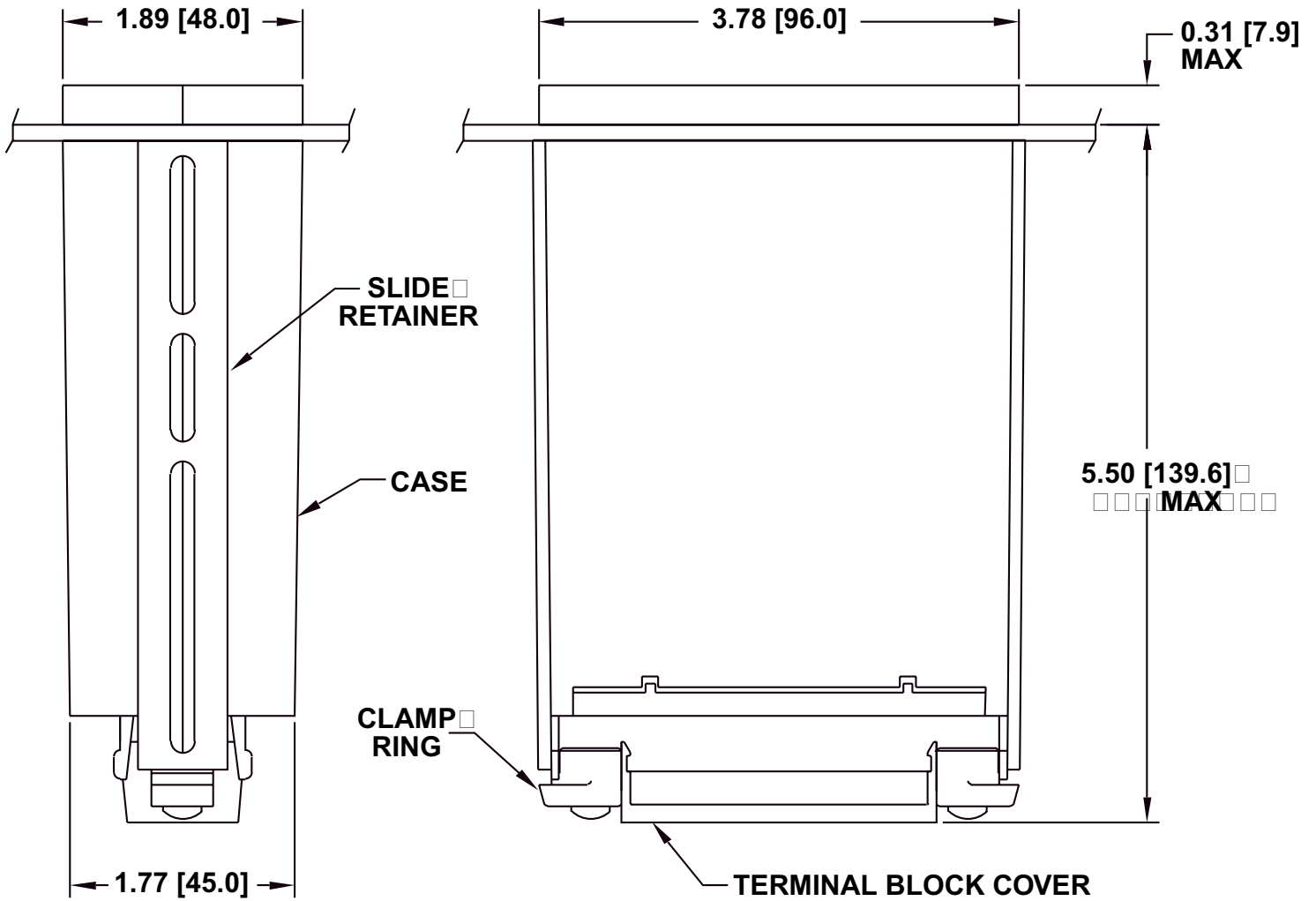

Notes: Dimensions are in inches ± 0.01 "
 with millimeters in [] ± 0.25 mm.

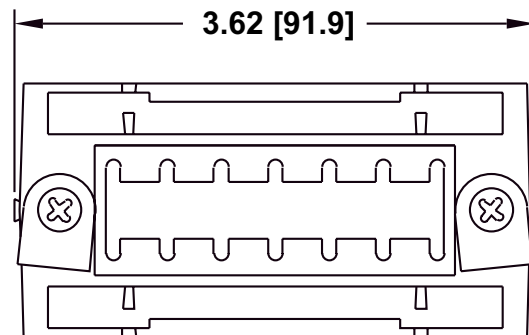
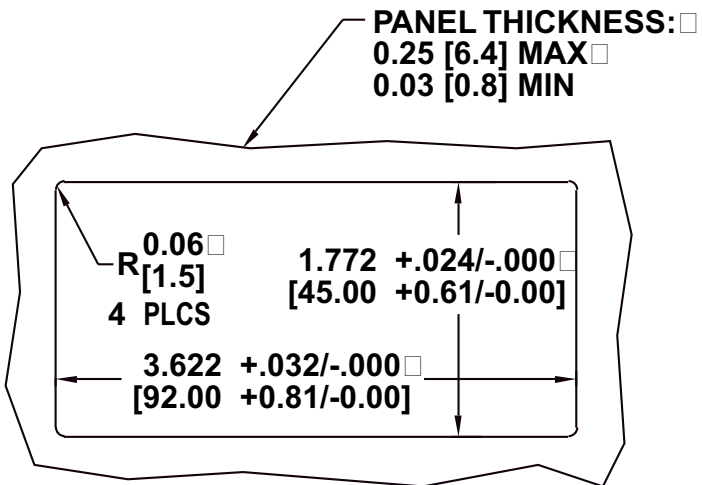

Terminal block cover and bezel not shown for clarity. Clamp rings rotated and slide retainers removed as shown for installation.

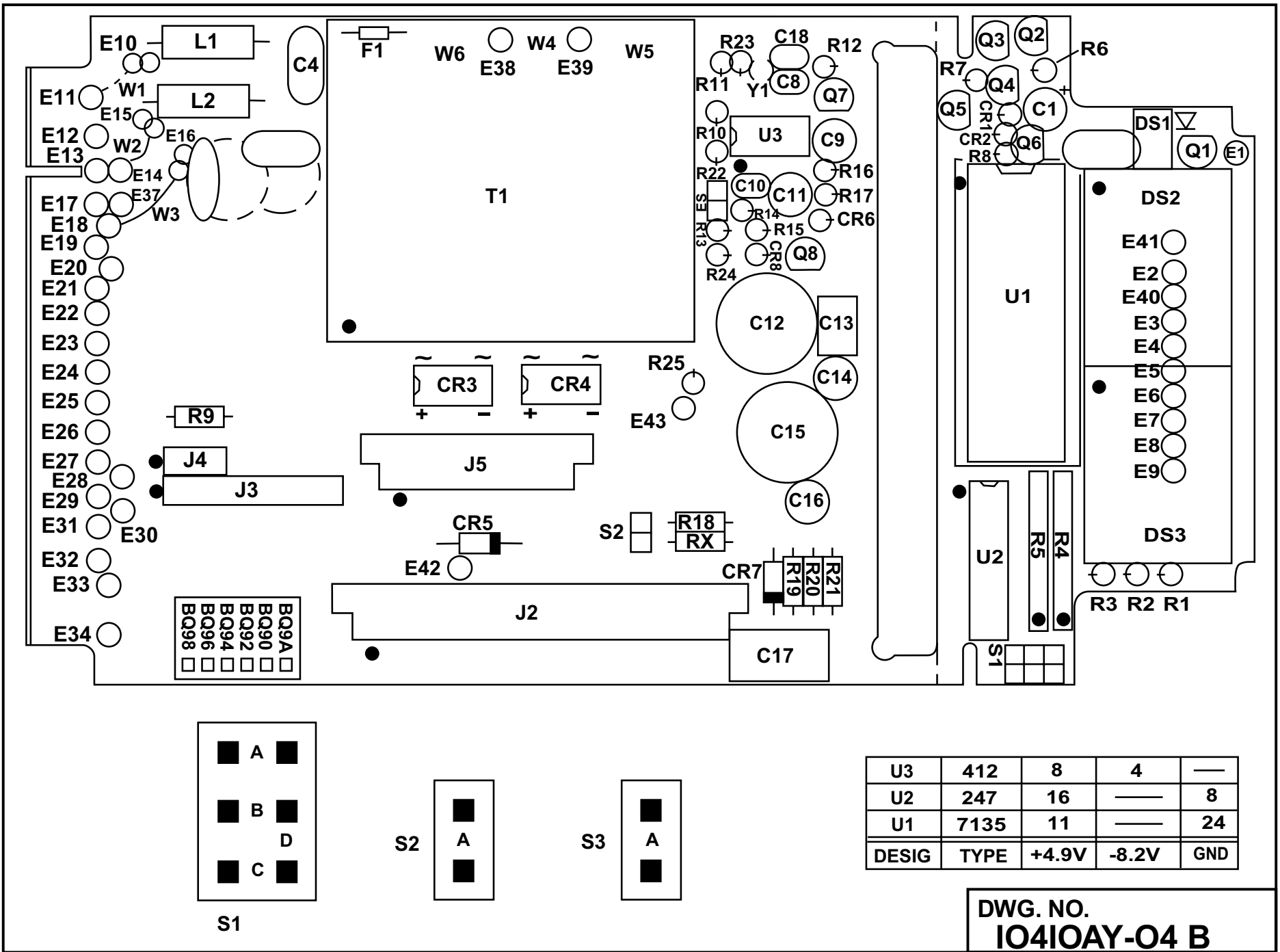

17.0 SPECIFICATIONS: BSCJ TYPE J THERMOCOUPLE INPUT

17.1 GENERAL

This option board, identified as BSCP (Q2000P or Q9000P), provides extensive offset and scaling capability, permitting a wide selection of readout span for input current spans of 1 to 50 mA FS or for input voltage spans of 0.5 to 20 V FS. The Q2000 or Q900 prefix is determined by the main assembly board used with the BSCP option board.

Selection of gain and offset ranges is made by push-on jumpers between 0.025" square pins on 0.1" centers. Six current ranges and six voltage ranges are provided, as well as push-on jumpers for offset and polarity to preserve the resolution and adjustability of the offset and gain potentiometers.

The BSCP has a restricted common-mode range: the BSCS strain gauge signal conditioner is recommended for signals with sizeable common-mode levels.

17.2 Q2000P & Q9000P: PROCESS SIGNAL INPUT SPECIFICATIONS

Configuration	Single-ended, meter ground common to input LO
Polarity	Bipolar
Span Ranges	Internally selectable by push-on jumpers 0 to 25% 25 to 50% 50 to 75% 75 to 100%
Zero Offset Ranges	Internally selectable by push-on jumpers -215 to -77 mV -77 to +54 mV +54 to +190 mV +165 to +295 mV
Fine Zero Offset	50% of full scale minimum (front panel adjustment by potentiometer)

VOLTAGE RECEIVER

Readout Range	-1999 TO +1999 (Q2000P)						
Readout Range	-9999 TO +9999 (Q9000P)						
Input Range	0.5	1.0	2.0	5.0	10.0	20.0	V FS
Input Impedance	0.10	0.25	0.50	1.09	1.04	1.02	MOhms
Bias Current	100	50	25	13	13	13	pA
NMR at 50/60 Hz	60	56	54	50	50	50	dB

Maximum Voltage: 250 Vp

DC CURRENT RECEIVER

Readout Range	-1999 TO +1999 (Q2000P)						
Readout Range	-9999 TO +9999 (Q9000P)						
Input Range	1.0	2.0	5.0	10.0	20.0	50.0	V FS
Maximum Current	16	22	35	50	70	112	mZA
Shunt Resistance	499	249	100	49.9	24.9	10.0	ohms
Full Scale Voltage Drop	0.5	0.5	0.5	0.5	0.5	0.5	V FS
NMR at 50/60 Hz	60	60	60	60	60	60	dB

Common Mode

Analog ground to ac ground

CMR at dc to 60 Hz 120 dB

CMV at dc to 60 Hz ± 1500 Vp per HV test
 ± 354 Vp per IEC spacing

Accuracy at 25°C

Maximum Errors
 Q2000P $\pm 0.05\%$ R ± 1 count
 Q9000P $\pm 0.05\%$ R ± 2 counts

Reading Tempco $\pm 0.01\%$ R/°C

Zero Tempco $\pm 0.01\%$ R/°C

Warmup to rated accuracy Less than 10 minutes

18.0 SIGNAL INPUT CONNECTIONS (TB1) (SEE FIGURE 5)

18.1 The signal input connections for the BSCJ thermocouple signal conditioner are made at the standard 3-terminal barrier strip:

<u>Terminal Connection</u>	<u>Signal</u>	<u>Input</u>
4	Analog GND	•
5	- Signal LO	— — — — — -
6	+ Signal HI	— — — — — +

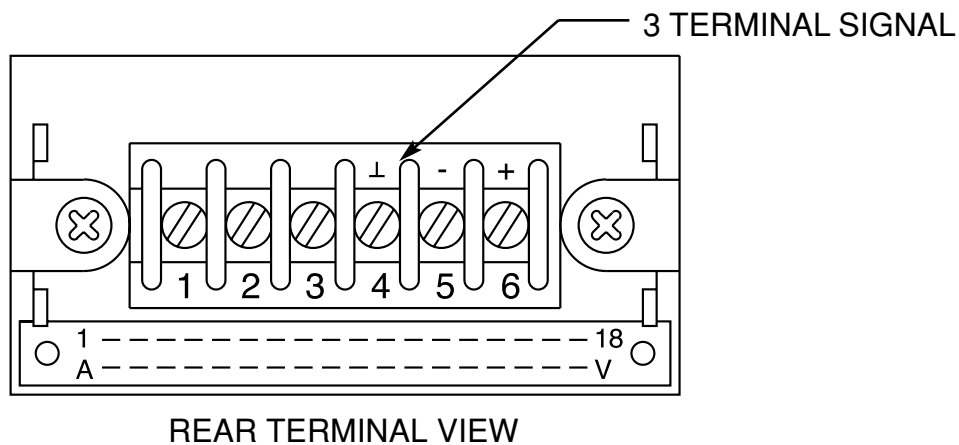

FIGURE 5. SIGNAL INPUT CONNECTIONS

19.0 TESTS AND DIAGNOSTICS

- The signal conditioner board BSCP is designed with a main assembly as a minimum configuration. There is no provision for testing a signal conditioner board alone.
- Signal input requirements for your configuration are identified in the specifications for the BSCP signal conditioner.
- Operating power and connections for your configuration are identified in the appropriate Main Assembly Section of this manual.

NOTE: If using Main Assembly Q2000, refer to Section BQ20/BQ29
If using Main Assembly Q9000, refer to Section BQ90/BQ98

- Inspect the panel meter for physical damage. If damage is apparent, resolve the damage with the shipper or your supplier.

19.1 FUNCTIONAL ELECTRICAL TESTING

NOTE: Perform this test after meter has been configured.

1. Short terminals 5 and 6 on barrier strip (TB1).
2. Apply proper power for your configuration to terminals 1, 2 and 3 on barrier strip (TB1).
3. Display will read approximately the zero offset number (ZON) from Section 20.3.

20.0 CONFIGURATION PROCEDURE

20.1 GENERAL

Use this procedure to determine the configuration of the BSCP Process Signal Option.

Configure the unit using push-on jumper provided separately or already positioned on the pin forests. Pin forests designations are shown with each configuration chart.

20.2 GLOSSARY

The chart below explains various terms which appear throughout the following procedure:

<u>Voltmeter Range Selection</u>	<u>Input Range, Fill Scale For Q2000P & Q9000P</u>
VM1	±190/235 mV
VM2	±233/350 mV
VM3	±348/450 mV
VM4	±440/580 mV
VM5	±575/850 mV
VM6	±800/1030 mV
VM7	±1.0/5.0 mV
VM8	±1.4/1.8 mV
VM9	±1.7/2.5 mV
VM10	±2.4/3.1 mV
VM11	±3.0/4.5 mV
VM12	±4.4/5.1 mV
VM13	±5.0/6.5 mV
VM14	±6.4/9.6 mV
VM15	±9.5/11.0 mV

<u>Current Range Selection</u>	<u>Input Range, Full Scale For Q2000P & Q9000P</u>
AM1	±370/470 mV
AM2	±460/700 mV
AM3	±690/800 mV
AM4	±790/940 mV
AM5	±935/1400 mV
AM6	±1.39/1.91 mV
AM7	±1.90/2.35 mV
AM8	±2.33/3.50 mV
AM9	±3.48/4.00 mV
AM10	±3.90/4.70 mV
AM11	±4.65/7.00 mV
AM12	±6.90/7.80 mV
AM13	±7.70/9.40 mV
AM14	±9.35/14.0 mV
AM15	±13.9/19.1 mV
AM16	±19.0/23.5 mV
AM17	±23.3/35.0 mV
AM18	±34.0/51.0 mV

<u>Zero Offset Selection</u>	<u>Output Count Offset Range</u>	
	<u>Q2000P</u>	<u>Q9000P</u>
Z01	-3000/-1895	-15000/-9475
Z02	-1900/-600	-9500/-3000
Z03	-605/+870	-3025/+4350
Z04	+865/+2100	+4325/+10500

<u>Abbr</u>	<u>Definition</u>
ZON	Zero Offset Number
LI	Lower Input Number
UI	Upper Input Number
LD	Lower Display Number
UD	Upper Display Number
G	Gain in Counts/Input

20.3 SELECTION

If the Input is to be configured as a:

- Voltmeter, proceed
- Ammeter, proceed to Selection 20.3.1
- Voltage Receiver, proceed to Section 20.3.3
- Current Receiver, proceed to Selection 20.3.2

20.3.2 Voltmeter Range Selection VM1,2,3,4,5,6,7,8,9,10,11,12,13,14,15 *

1. Specify the magnitude of the largest + or - input voltage:

Q2000P: VM = _____ Volts (For a 2000 count reading)

Q9000P: VM = _____ Volts (For a 10000 count reading)

2. Select the lowest range where VM (from step 1) is equal to or less

than

the limit of that range.

VM1 = 0.235 V VM6 = 1.030 V VM11 = 4.500 V

VM2 = 0.350 V VM7 = 1.500 V VM12 = 5.100 V

VM3 = 0.450 V VM8 = 1.800 V VM13 = 6.500 V

VM4 = 0.580 V VM9 = 2.500 V VM14 = 9.600 V

VM5 = 0.850 V VM10 = 3.100 V VM15 = 11.00 V

VM = _____ this selection will be used in configuring the meter (Section 21.1)

3. Proceed to Installation (section 20.4).

* Range Selection assumes that the meter has an offset range (Z03) selected which allows a shorted input to read 000 on the Q2000P display and 0000 on the Q9000P display.

4. Using the same LI, UI, LD and UD numbers, calculate the Gain (G) in Counts/Input.

$$\text{Gain (G)} = \frac{(\text{UD} - \text{LD})}{(\text{UI} - \text{LI})} = \underline{\hspace{2cm}}$$

5. Select the group of four VR ranges under the Input Span Range required.
6. Select one from the following group which contains the Gain (G) number calculated in step 4.

Voltage Receiver Selection	Input Span	Output Count Range	
		Q2000P	Q9000P
VR1	0/0.5 V	80/2850	400/14250
VR2	0/0.5 V	2840/5500	14200/27500
VR3	0/0.5 V	5490/8170	27450/40850
VR4	0/0.5 V	8160/10600	40800/53000
VR5	0/1.0 V	40/1260	200/6300
VR6	0/1.0 V	1255/2440	6275/12200
VR7	0/1.0 V	2430/3605	12150/18025
VR8	0/1.0 V	3595/4700	17975/23500
VR9	0/2.0 V	20/750	40/1155
VR10	0/2.0 V	745/1452	3725/7260
VR11	0/2.0 V	1450/2157	7250/1785
VR12	0/2.0 V	2155/2750	10775/13750
VR13	0/2.0 V	8/231	40/572
VR14	0/2.0 V	230/499	1150/2245
VR15	0/2.0 V	448/667	2240/3335
VR16	0/0.5 V	666/860	3330/4300
VR17	0/0.5 V	4/114.5	20/572
VR18	0/0.5 V	114/223	570/1115
VR19	0/0.5 V	222.5/331	570/1115
VR20	0/0.5 V	330.5/428	1652/2140
VR21	0/0.5 V	2/56.80	10/284
VR22	0/0.5 V	56.5/110.3	282/551
VR23	0/0.5 V	110/164.4	550/882
VR24	0/0.5 V	164.2/220	821/1100

VM = _____ this selection will be used in
configuring the meter (Section 21.1)

INSTALLATION

Select the degrees format required after calibration.

20.3.4 Current Receiver Selection

CR1, 2, 3, 4, 5, 6, 7, 8, 9, 10, 11, 12, 13, 14, 15, 16, 17, 18, 19, 20, 21, 22, 23, 24

1. Using the Input Span Range and the required Display Reading, calculate the zero offset required (with polarity).
(LI) Lower input = _____
(UI) Upper Input = _____
(LD) Lower Display = _____
(UD) Upper Display = _____
2. When specifying the Lower Input (LI) and Upper Input (UI), the maximum display reading for a Q2000P is ± 1999 . The maximum reading for a Q9000 is ± 9999 .
3. Select a Zero Offset Range (ZO) from the appropriate QUANTA series where the calculated Zero Offset Number (ZON) falls between the minimum and maximum numbers of that range.
4. Using the same LI, UI, LD and UD numbers, calculate the Gain (G) in Counts/Input.
$$\text{Gain (G)} = \frac{(\text{UD} - \text{LD})}{(\text{UI} - \text{LI})} = \underline{\hspace{2cm}}$$
5. Using the chart on the next page, select the Count Output Range required for the Input Span Range chosen.
6. Select the group of four CR ranges under the Input Span Range required.
7. Select one of the four ranges which contains the Gain (G) number calculated.

Voltage Receiver Selection	Input Span	Output Count Range	
		Q2000P	Q9000P
CR1	0.2/1.0 mA	50/1405	250/7025
CR2	0.2/1.0 mA	1400/2730	7000/13650
CR3	0.2/1.0 mA	2725/4055	13625/20275
CR4	0.2/1.0 mA	4050/5264	20250/26320
CR5	0.4/2.0 mA	25/702	125/3510
CR6	0.4/2.0 mA	700/1365	3500/6825
CR7	0.4/2.0 mA	1363/2027	6815/1135
CR8	0.4/2.0 mA	2025/2632	10125/31360
CR9	1.0/5.0 mA	10/282.5	50/1413
CR10	1.0/5.0 mA	281.5/550	1408/2750
CR11	1.0/5.0 mA	548/816	2740/4080
CR12	1.0/5.0 mA	815/1059	4075/5295
CR13	2.0/10.0 mA	5/141	25/705
CR14	2.0/10.0 mA	140.5/274.5	702/1372
CR15	2.0/10.0 mA	274/407.5	1370/2037
CR16	2.0/10.0 mA	407/529	2036/2645
CR17	4.0/20.0 mA	2.5/70.4	13/352
CR18	4.0/20.0 mA	70.2/137	351/685
CR19	4.0/20.0 mA	136.6/203.4	683/1017
CR20	4.0/20.0 mA	203/264	1015/1320
CR21	10.0/50.0 mA	1/28.2	5/141
CR22	10.0/50.0 mA	28.1/55	141/275
CR23	10.0/50.0 mA	54.8/81.6	274/408
CR24	10.0/50.0 mA	81.5/106	408/530

CR = _____ (counts/mA) This selection will be used in used in configuration (Selection 21.4)

8. Proceed to Installation (section 20,4)

20.4 INSTALLATION

20.4.1 General

If unit is to be configured as a voltmeter (VM1-15) or an ammeter (AM1-18) then zero offset (Z03) is required.

Select the Voltmeter (VM-15), Ammeter (AM1-18), Voltage Receiver (VR1-24), Current Receiver (CR1-24), and/or the Zero Offset (Z01-4) required. Install the push-on jumpers as per pages 44 through 52 depending on which range is required.

20.4.2 Reference Voltage (Q9000P only)

Select reference RV2 by removing any jumpers on position S3 as per Subsection 13.3 in Main Assembly Section BQ90/BQ98.

20.4.3 Decimal Point

If a decimal point is required, refer to the appropriate Main Assembly Section for location and configuration procedure.

NOTE: If using Main Assembly Q2000, refer to Section BQ20/BQ29.

If using Main Assembly Q9000, refer to Section BQ90/BQ98.

21. CONFIGURATION CHARTS

21.1 VOLTMETER (VM1-15)

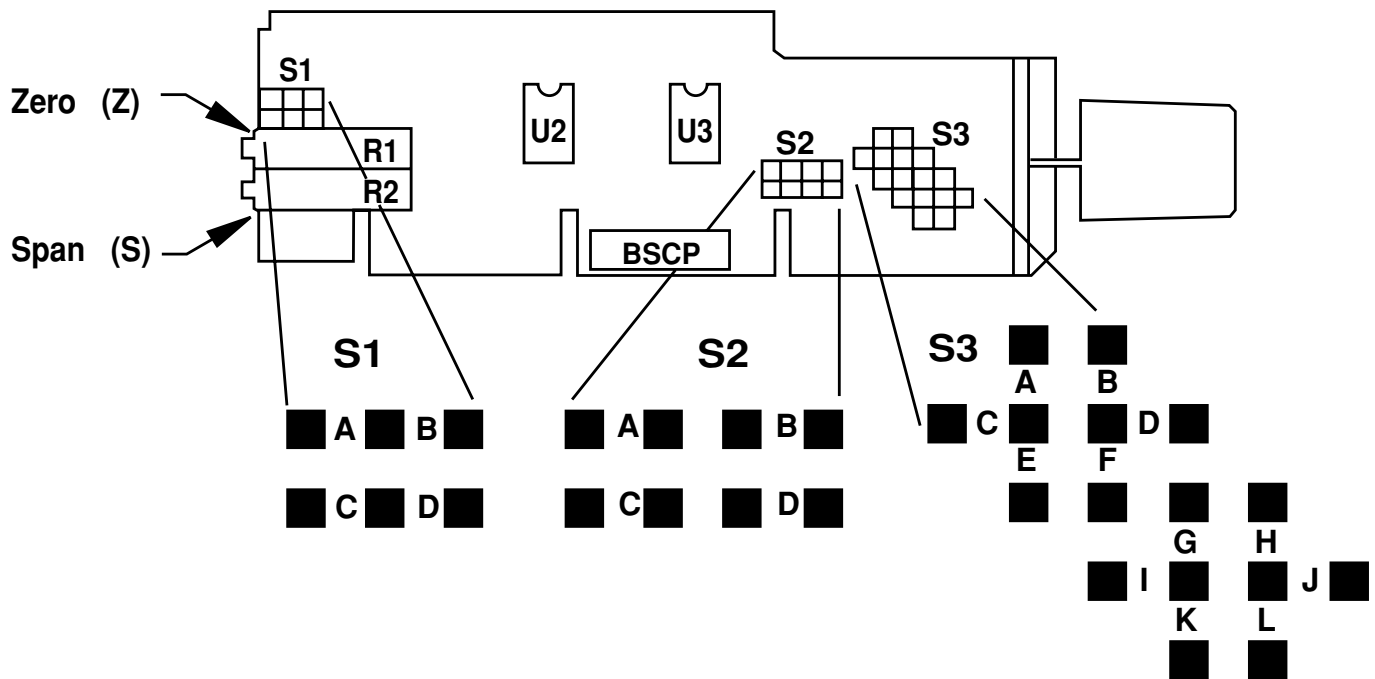

Step 1: Remove all push-on jumpers not used in the desired configuration(s).

Step 2: Select the desired configuration from the chart below, then install the push-on jumpers indicated.

Voltmeter Configuration*		S1	S2		S3		Input Resistance
VM1	±190/235 mV	B	C	D	G	-	100 kOhms
VM2	±233/350 mV	B	A	D	G	-	100 kOhms
VM3	±348/450 mV	B	B	C	G	-	100 kOhms
VM4	±440/580 mV	B	C	D	H	-	230 kOhms
VM5	±575/850 mV	B	A	D	H	-	230 kOhms
VM6	±800/1030 mV	B	C	D	J	-	230 kOhms

* Used on the Q2000P or Q9000P

21.1 VOLTMETER (VM7-15)

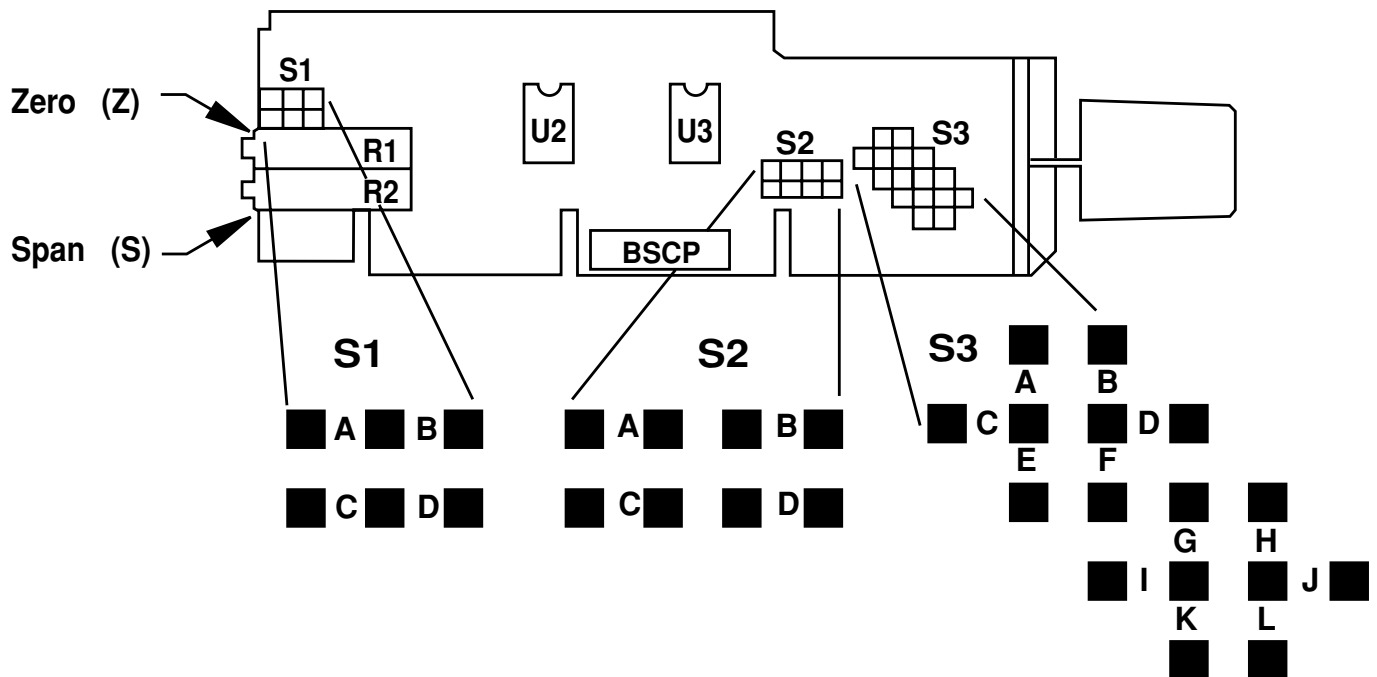

Voltmeter Configuration*		S1	S2		S3		Input Resistance
VM7	$\pm 1.0/1.5$ V	B	A	D	J	-	385 kOhms
VM8	$\pm 1.4/1.8$ V	B	C	D	J	K	325 kOhms
VM9	$\pm 1.2/2.5$ V	B	A	D	J	K	1 MOhms
VM10	$\pm 2.4/3.1$ V	B	C	D	I	-	1 MOhms
VM11	$\pm 3.0/4.5$ V	B	A	D	I	-	1 MOhms
VM12	$\pm 4.4/5.1$ V	B	B	C	I	-	1 MOhms
VM13	$\pm 5.0/6.5$ V	B	C	D	K	-	1 MOhms
VM14	$\pm 6.4/9.6$ V	B	A	D	K	-	1 MOhms
VM15	$\pm 9.5/11.0$ V	B	B	C	K	-	1 MOhms

* Used on the Q2000P or Q9000P

21.2 AMMETER (AM1-18)

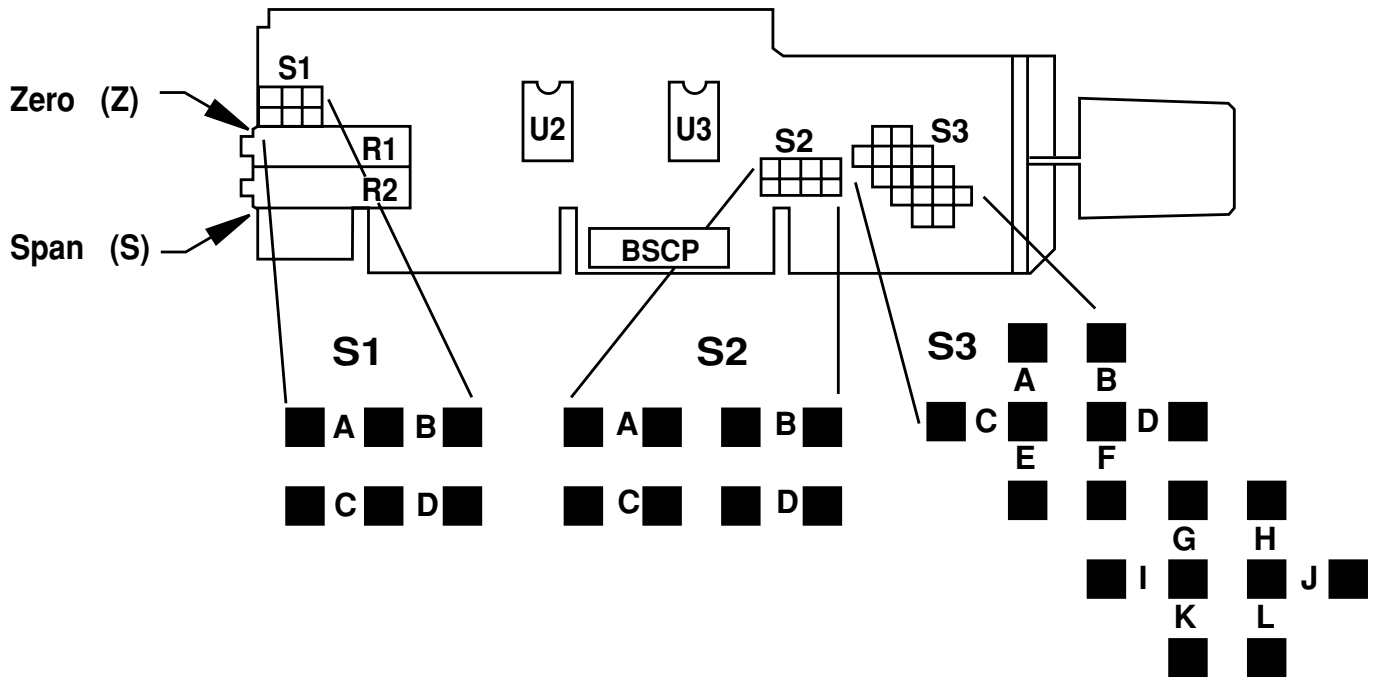

Step 1: Remove all push-on jumpers not used in the desired configuration(s).

Step 2: Select the desired configuration from the chart below, then install the push-on jumpers indicated.

Ammeter Configuration*		S1	S2		S3		Input Resistance
AM1	$\pm 370/470 \mu\text{A}$	B	C	D	A	G	490 ohms
AM2	$\pm 460/700 \mu\text{A}$	B	A	D	A	G	490 ohms
AM3	$\pm 690/800 \mu\text{A}$	B	B	C	A	G	490 ohms
AM4	$\pm 790/940 \mu\text{A}$	B	C	D	B	G	240 ohms
AM5	$\pm 935/1400 \mu\text{A}$	B	A	D	B	G	240 ohms
AM6	$\pm 1.39/1.91 \text{ mA}$	B	B	C	B	G	240 ohms ³

* Used on the Q2000P or Q9000P

21.1 VOLTMETER (VM7-15)

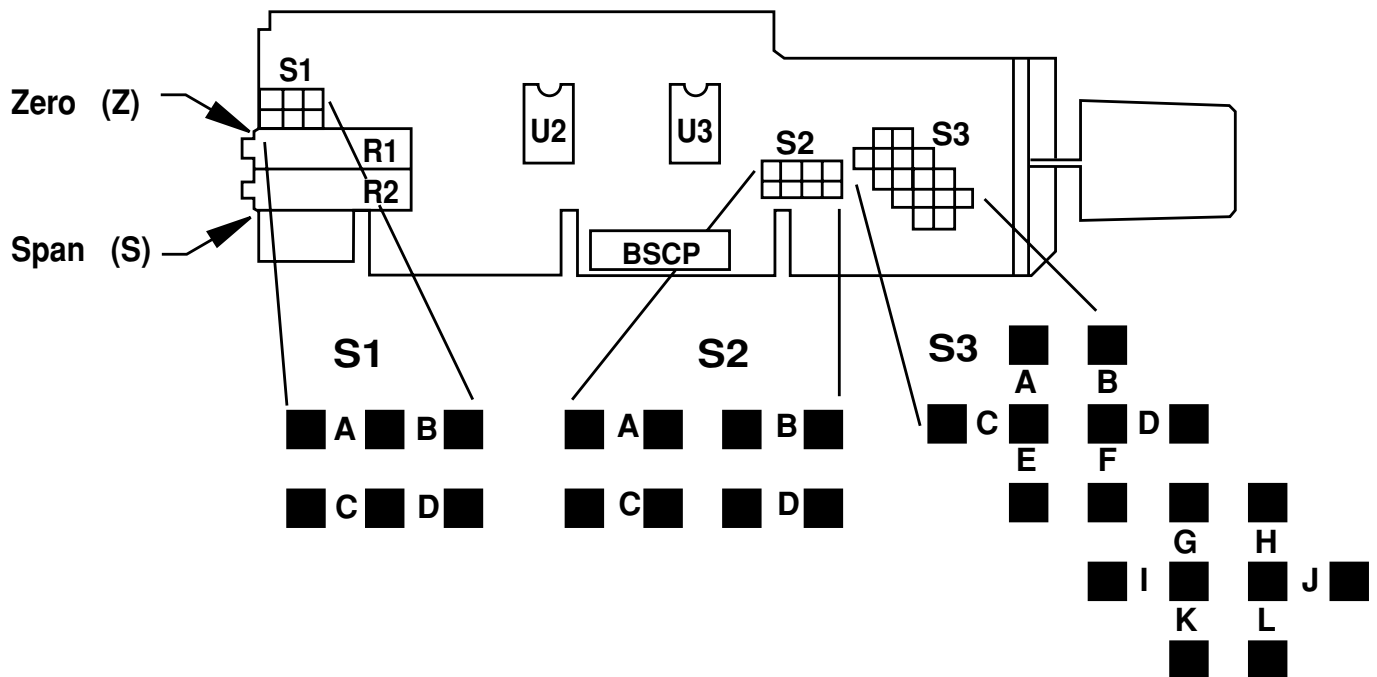

Ammeter Configuration*		S1	S2		S3		Input Resistance
AM7	$\pm 1.90/2.35$ mA	B	C	D	D	G	100 ohms
AM8	$\pm 2.33/3.50$ mA	B	A	D	D	G	100 ohms
AM9	$\pm 3.48/4.00$ mA	B	B	C	D	G	100 ohms
AM10	$\pm 3.90/4.70$ mA	B	C	D	F	G	50 ohms
AM11	$\pm 4.65/7.00$ mA	B	A	D	F	G	50 ohms
AM12	$\pm 6.90/7.80$ mA	B	B	C	F	G	50 ohms
AM13	$\pm 7.70/9.40$ mA	B	C	D	E	G	25 ohms
AM14	$\pm 9.35/14.0$ mA	B	A	D	E	G	25 ohms
AM15	$\pm 13.9/19.1$ mA	B	B	C	E	G	25 ohms
AM16	$\pm 19.0/23.5$ mA	B	C	D	C	G	10 ohms
AM17	$\pm 23.3/35.0$ mA	B	A	D	C	G	10 ohms
AM18	$\pm 34./51.0$ mA	B	B	C	C	G	10 ohms

* Used on the Q2000P or Q9000P

21.2 VOLTAGE RECEIVER (VR1-24)

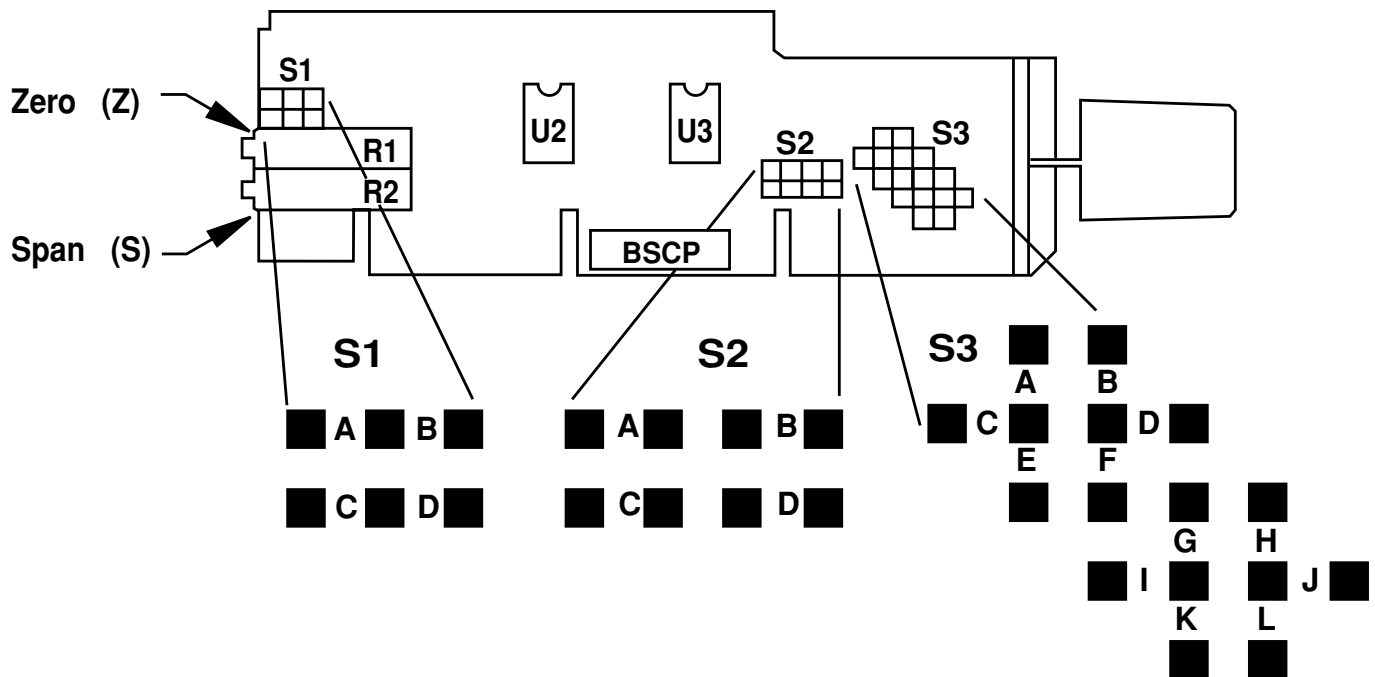

Step 1: Remove all push-on jumpers not used in the desired configuration(s).

Step 2: Select the desired configuration from the chart below, then install the push-on jumpers indicated.

Voltage Receiver Configuration*		S2		S3	Counts/Volts Q2000P	Counts/Volts Q9000P
VR1	0.5 V Input	A	B	G	80/2850	400/14250
VR2	0.5 V Input	B	C	G	2840/5500	14200/27500
VR3	0.5 V Input	A	D	G	5490/8170	27450/40850
VR4	0.5 V Input	C	D	G	8160/10600	40800/53000
VR5	1.0 V Input	A	B	H	40/1260	200/6300
VR6	1.0 V Input	B	C	H	1255/2440	6275/12200
VR7	1.0 V Input	A	D	H	2430/3605	12150/18025
VR8	1.0 V Input	C	D	H	3595/4700	17975/23500
VR9	2.0 V Input	A	B	J	20/750	100/3750
VR10	2.0 V Input	B	C	J	745/1452	3725/7260

* Used on the Q2000P or Q9000P

21.2 VOLTAGE RECEIVER (VR11-24)

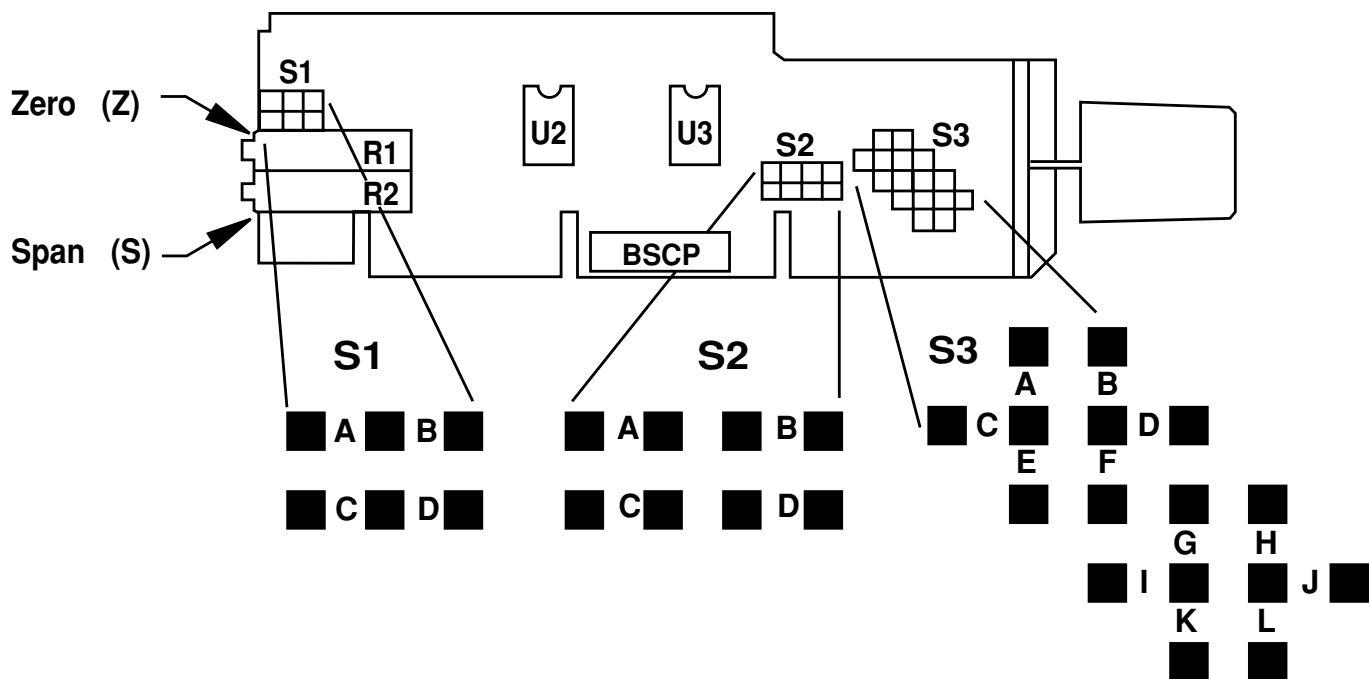

Voltage Receiver Configuration*		S2		S3	Counts/Volts Q2000P	Counts/Volts Q9000P
VR11	2.0 V Input	A	D	J	1450/2157	7250/1785
VR12	2.0 V Input	C	D	J	2155/2750	10775/13750
VR13	5.0 V Input	A	B	I	8/2231	40/1155
VR14	5.0 V Input	B	C	I	230/449	1150/2245
VR15	5.0 V Input	A	D	I	448/667	2240/3335
VR16	5.0 V Input	C	D	I	666/860	3330/4300
VR17	10.0 V Input	A	B	K	4/114.5	20/572
VR18	10.0 V Input	B	C	K	114/223	570/1115
VR19	10.0 V Input	A	D	K	222.5/331	1110/1655
VR20	10.0 V Input	C	D	K	330.5/428	1652/2140
VR21	20.0 V Input	A	B	L	2/56.8	10/284
VR22	20.0 V Input	B	C	L	56.5/110.3	282/551
VR23	20.0 V Input	A	D	L	110/164.4	550/822
VR24	20.0 V Input	C	D	L	164.2/220	820/1100

21.2 CURRENT RECEIVER (CR1-24)

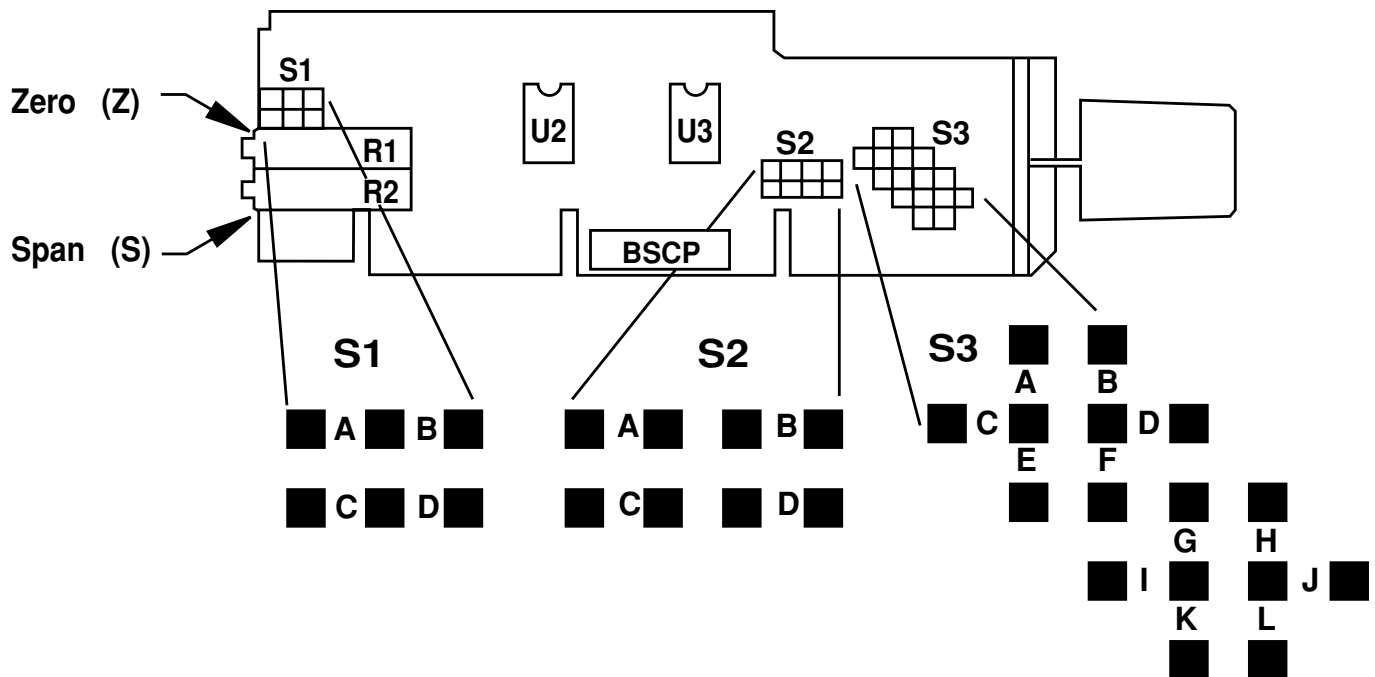

Step 1: Remove all push-on jumpers not used in the desired configuration(s).

Step 2: Select the desired configuration from the chart below, then install the push-on jumpers indicated.

Voltage Receiver Configuration*		S2		S3		Counts/Volts Q2000P	Counts/Volts Q9000P
CR1	0.2/1.0 mA Input	A	B	A	G	50/1405	250/7025
CR2	0.2/1.0 mA Input	B	C	A	G	1400/273	7000/13650
CR3	0.2/1.0 mA Input	A	D	A	G	2725/4055	13625/20275
CR4	0.2/1.0 mA Input	C	D	A	G	4050/5264	20250/26320
CR5	0.4/2.0 mA Input	A	B	B	G	25/702	125/3510
CR6	0.4/2.0 mA Input	B	C	B	G	700/1365	3500/6825
CR7	0.4/2.0 mA Input	A	D	B	G	1363/2027	6815/10135
CR8	0.4/2.0 mA Input	C	D	B	G	2025/26320	10125/13160
CR9	1.0/5.0 mA Input	A	B	D	G	10/282.5	50/1412
CR10	1.0/5.0 mA Input	B	C	D	G	281.5/550	147/2750

* Used on the Q2000P or Q9000P

CURRENT RECEIVER (CR11-24)

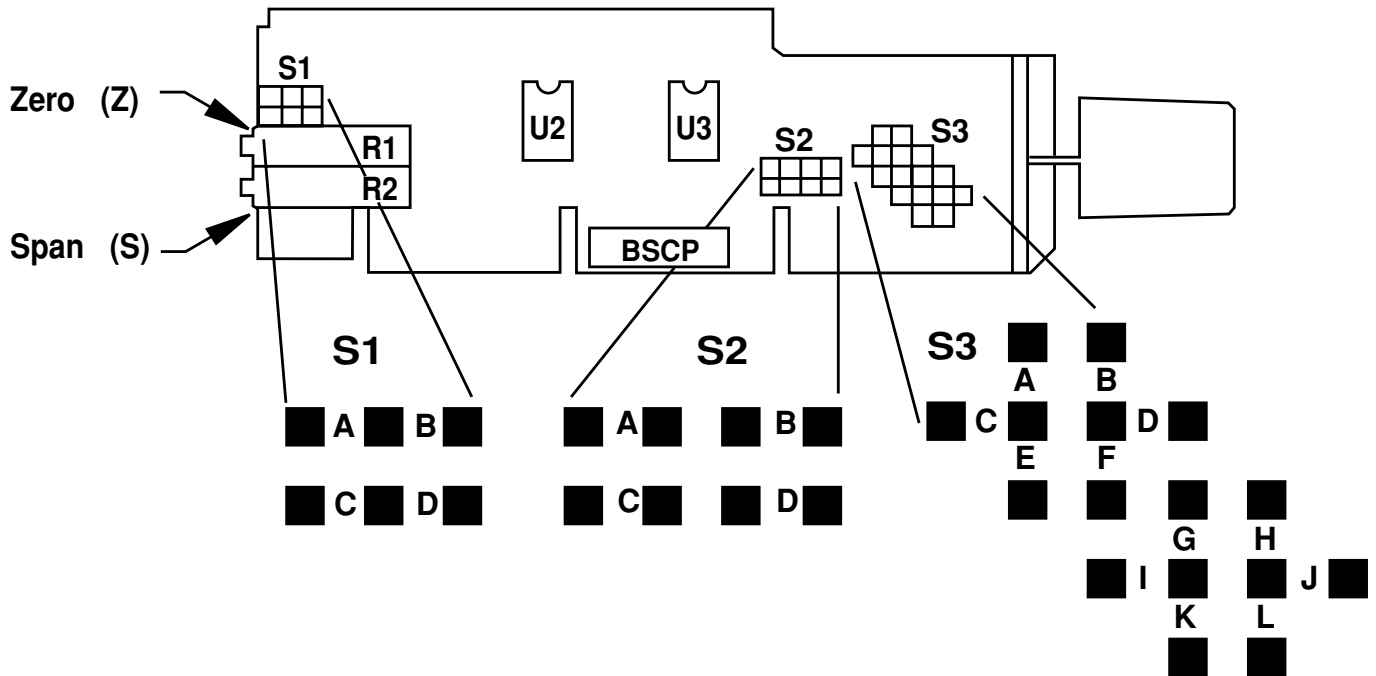

Voltage Receiver Configuration*		S2		S3		Counts/Volts Q2000P	Counts/Volts Q9000P
CR11	1.0/5.0 mA Input	A	D	D	G	548/816	2740/4080
CR12	1.0/5.0 mA Input	C	D	D	G	815/1059	4075/5295
CR13	2.0/10.0 mA Input	A	B	F	G	5/141	25/705
CR14	2.0/10.0 mA Input	B	C	F	G	140.5/274.5	702/1372
CR15	2.0/10.0 mA Input	A	D	F	G	274/407.5	21370/2037
CR16	2.0/10.0 mA Input	C	D	F	G	407/529	2035/2645
CR17	4.0/20.0 mA Input	A	B	E	G	2.5/70.4	12/352
CR18	4.0/20.0 mA Input	B	C	E	G	7.2/137	351/685
CR19	4.0/20.0 mA Input	A	D	E	G	136.6/203.4	683/1017
CR20	4.0/20.0 mA Input	C	D	E	G	203/264	1015/1320
CR21	10.0/50.0 mA Input	A	B	C	G	1/28.2	5/141
CR22	10.0/50.0 mA Input	B	C	C	G	28.1/55	140/275
CR23	10.0/50.0 mA Input	A	D	C	G	54.8/81.6	274/408
CR24	10.0/50.0 mA Input	C	D	C	G	81.5/106	407/530

21.2 ZERO OFFSET (ZO1-4)

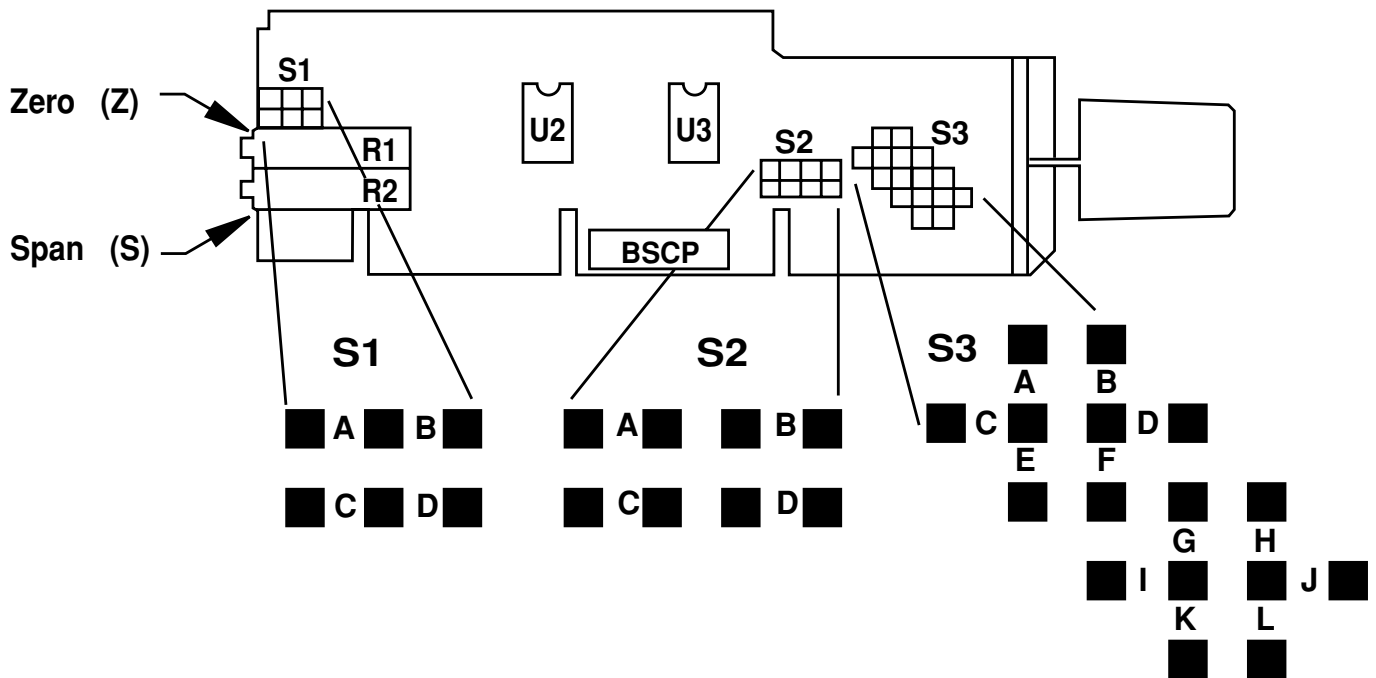

Step 1:		Remove all push-on jumpers not used in the desired configuration(s).	
Step 2:		Select the desired configuration from the chart below, then install the push-on jumpers indicated.	
Zero Offset Configuration			
	Q2000P	Q9000P	S1
ZO1	-3000/-1895 counts	-15000/-9475 counts	A
ZO2	-1900/-600 counts	-9500/-3000 counts	C
ZO3	-605/+870 counts	-3025/+4350 counts	B
ZO4	+865/+2100 counts	+4325/+10500 counts	D

22.0 CALIBRATION FOR Q2000P

NOTE: The numbers used bellow are derived from the selection Section 20.3.

22.1 VOLTMETER (VM1-15)

1. Apply a short to the input terminals and adjust the zero (z) pot (R1) to make the display read 000.
2. Apply an Input Voltage equal to the largest (+) magnitude of the VM range selected and adjust the span (s) pot (R2) to make the display read the appropriate number.
3. Repeat above steps as required to set the display within ± 1 count.

22.2 AMMETER (AM1-18)

1. Apply a short to the input terminals and adjust the zero (z) pot (R1) to make the display read 000.
2. Apply an Input Current equal to the largest (+) magnitude of the AM range selected and adjust the span (s) pot (R2) to make the display read the appropriate number.
3. Repeat above steps as required to set the display within ± 1 count.

22.3 VOLTAGE RECEIVER (VR1-24)

1. Apply a short to the input terminals and adjust the zero (Z) pot (R1) to make the display read the Zero Offset Number (ZON) calculated.
2. Apply an Input Voltage equal to the Upper Input (UI) number used and adjust the span (s) pot (R2) to make the display read that number.
3. Repeat above steps as required to set the display within ± 1 count.

22.4 CURRENT RECEIVER (CR1-24)

1. Apply a short to the input terminals and adjust the zero (Z) pot (R1) to make the display read the Zero Offset Number (ZON) calculated.
2. Apply an Input Voltage equal to the Upper Input (UI) number used and adjust the span (s) pot (R2) to make the display read that number.
3. Repeat above steps as required to set the display within ± 1 count.

23.0 CALIBRATION FOR Q9000P

NOTE: The numbers used below are derived from the selection Section 20.3.

22.1 VOLTMETER (VM1-15)

1. Apply a short to the input terminals and adjust the zero (z) pot (R1) to make the display read 0000.
2. Apply an Input Voltage equal to the largest (+) magnitude of the VM range selected and adjust the span (s) pot (R2) to make the display read the appropriate number.
3. Repeat above steps as required to set the display within ± 1 count.

22.2 AMMETER (AM1-18)

1. Apply a short to the input terminals and adjust the zero (z) pot (R1) to make the display read 0000.
2. Apply an Input Current equal to the largest (+) magnitude of the AM range selected and adjust the span (s) pot (R2) to make the display read the appropriate number.
3. Repeat above steps as required to set the display within ± 1 count.

22.3 VOLTAGE RECEIVER (VR1-24)

1. Apply a short to the input terminals and adjust the zero (Z) pot (R1) to make the display read the Zero Offset Number (ZON) calculated.
2. Apply an Input Voltage equal to the Upper Input (UI) number used and adjust the span (s) pot (R2) to make the display read that number.
3. Repeat above steps as required to set the display within ± 1 count.

22.4 CURRENT RECEIVER (CR1-24)

1. Apply a short to the input terminals and adjust the zero (Z) pot (R1) to make the display read the Zero Offset Number (ZON) calculated.
2. Apply an Input Voltage equal to the Upper Input (UI) number used and adjust the span (s) pot (R2) to make the display read that number.
3. Repeat above steps as required to set the display within ± 1 count.

25.0 DIGITAL PANEL METER INSTALLATION INSTRUCTIONS

IMPORTANT:

For proper installation electrical connections must be made according to the model number on the meter label. Write the model number in the following space and use the appropriate instructions for your model number.

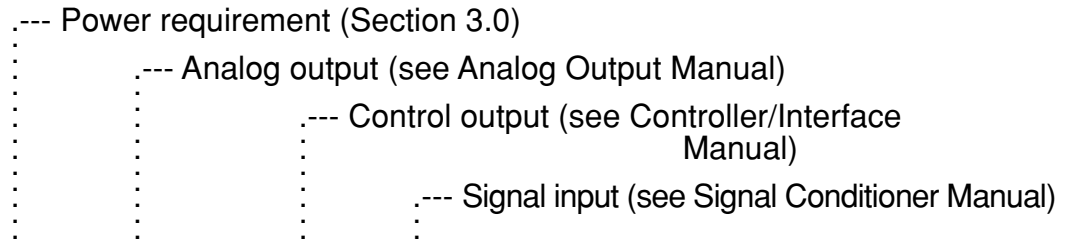

Model number Q2 _____

Model number Q9 _____

24.1 UNPACKING & INSPECTION

Your digital panel meter was systematically inspected and tested, then carefully packed before shipment.

Unpack the instrument and inspect for obvious shipping damage. Notify the freight carrier immediately upon discovery of any shipping damage.

24.2 MECHANICAL INSTALLATION

1. Insure that the panel cutout dimensions are as shown on figure next page.
2. Remove the lower printed circuit board edge connector, (if installed) J1, by pushing two molded plastic tabs away from the connector body and pulling the connector off the printed circuit board. Remove the printed circuit board edge connector, J2, if upper board output option was ordered.
3. Loosen two clamp screws on the rear of the case enough to rotate the two slide clamps.
4. Slide the two slide retainers toward the rear of the case and remove them.
5. From the front of the panel, insert the meter into the panel cutout.
6. Slide the slide retainers back onto the case and push up tightly against the rear of the panel.
7. Rotate the slide clamps back into their original position and tighten enough to hold the case in place. Overtightening can break the clamps.
8. Install the lower printed circuit board edge connector, if supplied, by pushing it on to the printed circuit board connections. Install the upper printed circuit board edge connector, if used.

PANEL THICKNESS

6,4 (.25) MAX
0,8 (.03) MIN

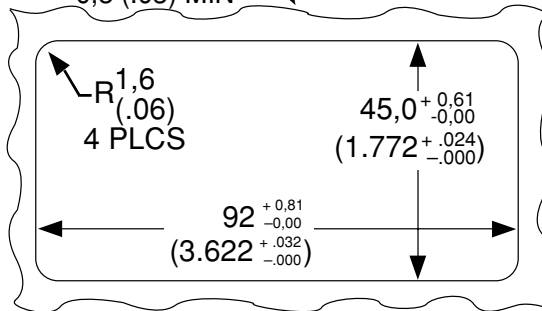

NOTE: Dimensions in Millimeters (Inches)

PANEL CUTOUT

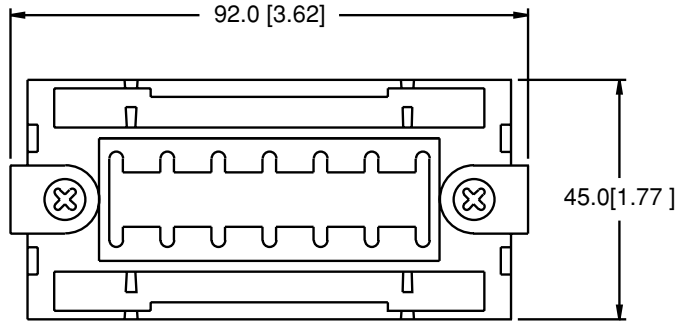

REAR VIEW

(TERMINAL BLOCK COVER AND BEZEL NOT SHOWN FOR CLARITY)
SLIDE CLAMPS ROTATED AND SLIDE RETAINERS
REMOVED AS SHOWN FOR INSTALLATION.

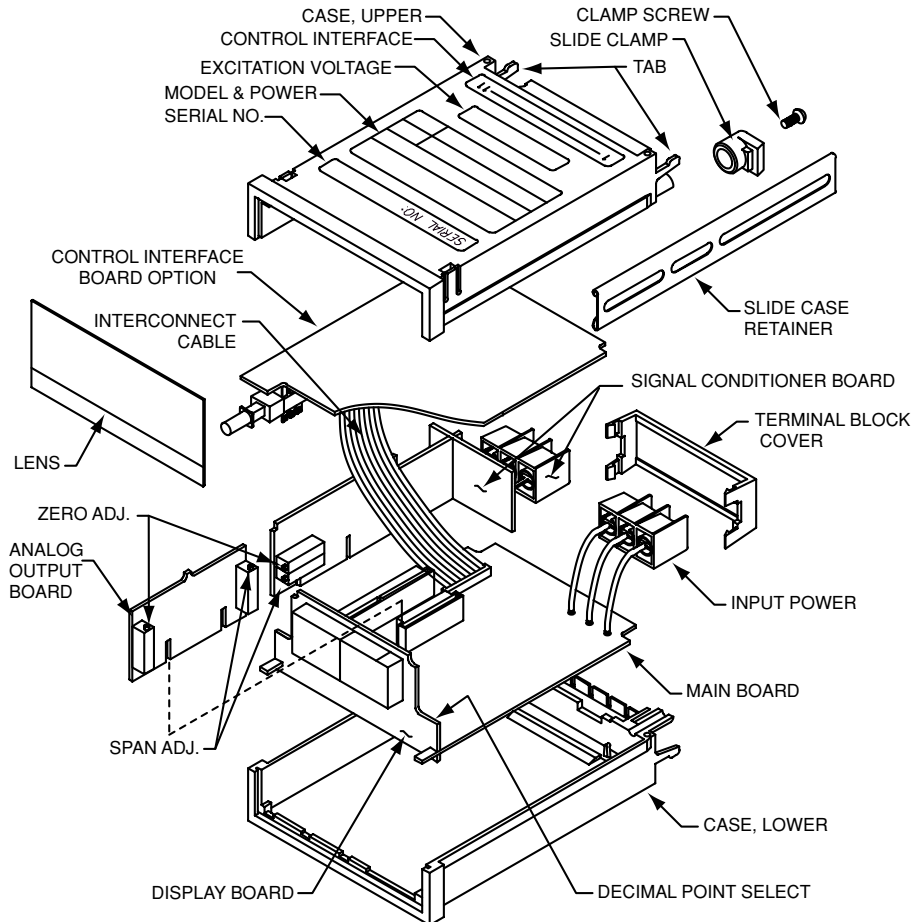

25.3.1 The standard meter is wired to operate from one of five power sources

Models	Power Requirements
Q20XXX, Q21XXX, Q90XXX	120 V ac (50-60 Hz)
Q22XXX, Q23XXX, Q92XXX	240 V ac (50-60 Hz)
Q24XXX, Q25XXX, Q94XXX	9-32 V dc
Q26XXX, Q27XXX, Q96XXX	5 V dc
Q28XXX, Q29XXX, Q98XXX	24 v ac (50-60 Hz)

24.3.2 Regardless of the power source used, connections are made to the same terminal barrier strip, TB1, as follows:

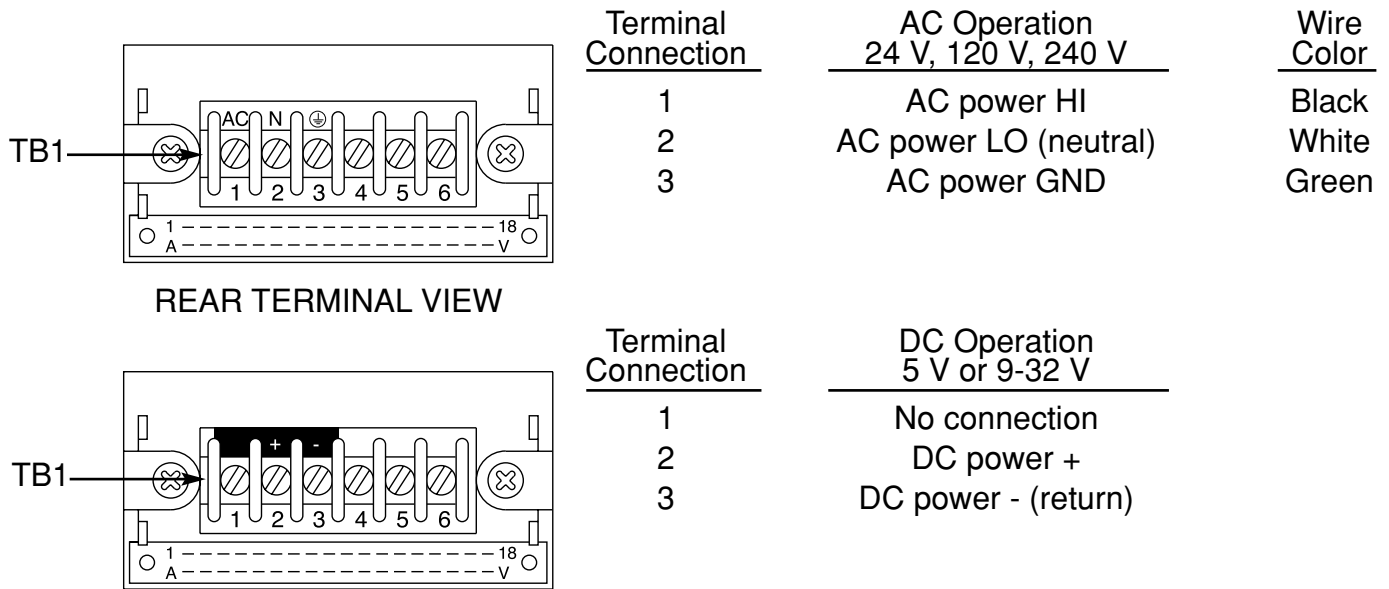

26.0 SIGNAL INPUT CONNECTIONS (TB1) (SEE FIGURE 5)

26.1 The signal input connections for the BSCJ thermocouple signal conditioner are made at the standard 3-terminal barrier strip:

Terminal Connection	Signal	Input
4	Analog GND	•
5	- Signal LO	— — -
6	+ Signal HI	— — +

