

SIEMENS

SIMATIC

ET 200BL

Interface module IM 155-8 PN
(6ES7155-8AR00-0AN0)

Equipment Manual

Introduction

1

Industrial Cybersecurity

2

Product overview

3

Wiring

4

Interrupts, error messages,
diagnostics and system
alarms

5

Technical specifications

6



Dimension drawing

A

Legal information

Warning notice system

This manual contains notices you have to observe in order to ensure your personal safety, as well as to prevent damage to property. The notices referring to your personal safety are highlighted in the manual by a safety alert symbol, notices referring only to property damage have no safety alert symbol. These notices shown below are graded according to the degree of danger.

 DANGER
indicates that death or severe personal injury will result if proper precautions are not taken.
 WARNING
indicates that death or severe personal injury may result if proper precautions are not taken.
 CAUTION
indicates that minor personal injury can result if proper precautions are not taken.
NOTICE
indicates that property damage can result if proper precautions are not taken.

If more than one degree of danger is present, the warning notice representing the highest degree of danger will be used. A notice warning of injury to persons with a safety alert symbol may also include a warning relating to property damage.

Qualified Personnel

The product/system described in this documentation may be operated only by **personnel qualified** for the specific task in accordance with the relevant documentation, in particular its warning notices and safety instructions. Qualified persons are those who, because of their training and experience, are familiar with the installation, assembly, commissioning, operation, decommissioning and disassembly of the product and can recognize risks and avoid possible hazards.

Proper use of Siemens products

Note the following:

 WARNING
Siemens products may only be used for the application described in the catalog and the associated usage information. If products and components from other manufacturers are used, these must be recommended or approved by Siemens. Proper transport, storage, installation, assembly, commissioning, operation and maintenance are required to ensure that the products operate safely and without any problems. The permissible ambient conditions must be complied with. The information in the relevant documentation must be observed.

Trademarks

All names identified by ® are registered trademarks of Siemens Aktiengesellschaft. The remaining trademarks in this publication may be trademarks whose use by third parties for their own purposes could violate the rights of the owner.

Disclaimer of Liability

We have reviewed the contents of this publication to ensure consistency with the hardware and software described. Since variance cannot be precluded entirely, we cannot guarantee full consistency. However, the information in this publication is reviewed regularly and any necessary corrections are included in subsequent editions.

Table of contents

1	Introduction.....	5
1.1	Introduction.....	5
1.2	Siemens Industry Online Support.....	6
1.3	SiePortal.....	6
1.4	ET 200BL Documentation Guide.....	7
1.4.1	Tool support.....	8
1.4.2	MultiFieldbus Configuration Tool (MFCT).....	8
1.4.3	SIMATIC Technical Documentation.....	10
2	Industrial Cybersecurity.....	12
2.1	Introduction to industrial cybersecurity.....	12
2.2	Cybersecurity information.....	12
2.3	Cybersecurity-relevant information.....	13
3	Product overview.....	14
3.1	Properties.....	14
3.2	Functions.....	16
3.2.1	Supported Ethernet services: ICMP, ARP, SNMP, LLDP.....	17
3.2.2	Port diagnostics.....	18
3.2.3	Disabling of ports.....	18
3.2.4	Isochronous real-time communication.....	18
3.2.5	Minimum update time 1 ms.....	19
3.2.6	Device replacement with topological configuration.....	19
3.2.7	Reading out service data.....	19
3.2.8	Reset to factory settings via PROFINET IO.....	20
3.2.9	Firmware update via PROFINET IO.....	20
3.2.10	Identification data I&M 0 to I&M 3.....	20
4	Wiring.....	21
4.1	Terminal assignment.....	21
4.2	Wiring diagram.....	22
5	Interrupts, error messages, diagnostics and system alarms.....	23
5.1	Status and error displays.....	23
5.2	Interrupts.....	26
5.2.1	Triggering a diagnostics interrupt.....	27
5.2.2	Triggering a hardware interrupt.....	27
5.2.3	Triggering a pull/plug interrupt.....	27

5.3	Alarms.....	28
5.3.1	Diagnostics alarms.....	28
5.3.2	Maintenance events.....	29
5.3.3	Channel diagnostics.....	29
5.3.4	Invalid configuration states of the ET 200BL on PROFINET IO.....	30
5.3.5	STOP of the IO controller and recovery of the IO device.....	31
6	Technical specifications.....	32
A	Dimension drawing.....	36

Introduction

1.1 Introduction

Purpose of the documentation

This documentation provides important information on configuring, installing, wiring and commissioning the ET 200BL distributed I/O system.

Basic knowledge required

A basic knowledge of automation technology is required to understand the documentation.

Validity of the documentation

This documentation applies to the distributed I/O system, ET 200BL.

Conventions

Please pay particular attention to notes highlighted as follows:

NOTE

Notes contain important information on the product, handling the product or on part of the documentation to which you should pay particular attention.

ID link for the digital nameplate



The ID Link is a globally unique identifier according to IEC 61406, which you will find in the future as a QR code on your product.

The figure shows an example of an ID link for the digital input module DI 16x24 VDC.

You can recognize the ID link by the frame with a black frame corner at the bottom right. The ID link takes you to the digital nameplate of your product.

Scan the QR code on the product or on the packaging label with a smartphone camera, barcode scanner or reader app. Call the ID link.

In the digital nameplate, you will find product data, manuals, declarations of conformity, certificates and other helpful information about your product.

Standards

You can find a dated reference to the respective standards or the EU Declaration of Conformity on the Internet (<https://sieportal.siemens.com/su/blGul>).

1.2 Siemens Industry Online Support

You can find current information on the following topics quickly and easily here:

- **Product support**
All the information and extensive know-how on your product, technical specifications, FAQs, certificates, downloads, and manuals.
- **Application examples**
Tools and examples to solve your automation tasks – as well as function blocks, performance information and videos.
- **Services**
Information about Industry Services, Field Services, Technical Support, spare parts and training offers.
- **Forums**
For answers and solutions concerning automation technology.
- **mySupport**
Your personal working area in Industry Online Support for messages, support queries, and configurable documents.

This information is provided by the Siemens Industry Online Support in the Internet (<https://support.industry.siemens.com>).

1.3 SiePortal

SiePortal is the catalog and ordering system of Siemens AG for automation and drive solutions on the basis of Totally Integrated Automation (TIA) and Totally Integrated Power (TIP).

You can find catalogs for all automation and drive products on the Internet (<https://mall.industry.siemens.com>).

1.4 ET 200BL Documentation Guide



The documentation for the SIMATIC ET 200BL distributed I/O system is arranged into three areas.

This arrangement enables you to access the specific content you require.

You can download the documentation free of charge from the Internet (<https://support.industry.siemens.com/cs/de/en/view/109987785>).

Basic information



The System Manual describes in detail the configuration, installation, wiring and commissioning of the SIMATIC ET 200BL distributed I/O system.

The online help of STEP 7 (TIA Portal) and STEP 7 MicroWIN support you during configuration and programming.

Examples:

- ET 200BL System Manual
- Online help TIA Portal
- STEP 7 MicroWIN online help

Device information



Equipment manuals contain a compact description of the module-specific information, such as properties, wiring diagrams, characteristics and technical specifications.

Examples:

- Equipment Manuals Interface Modules
- Equipment Manuals Digital Modules
- Equipment Manuals Analog Modules

General information



The function manuals contain detailed descriptions on general topics relating to the SIMATIC ET 200BL distributed I/O system.

Examples:

- Function Manual Diagnostics
- Function Manual Communication
- PROFINET Function Manual
- Function Manual Designing Interference-free Controllers

Manual Collection ET 200BL

The Manual Collection contains the complete documentation on the SIMATIC ET 200BL distributed I/O system gathered together in one file.

You can find the Manual Collection on the Internet.

(<https://support.automation.siemens.com/WW/view/en/109987784>)

1.4.1 Tool support

Tools

The tools described below support you in all steps: from planning, over commissioning, all the way to analysis of your system.

TIA Selection Tool

The TIA Selection Tool tool supports you in the selection, configuration, and ordering of devices for Totally Integrated Automation (TIA).

As successor of the SIMATIC Selection Tools, the TIA Selection Tool assembles the already known configurators for automation technology into a single tool.

With the TIA Selection Tool, you can generate a complete order list from your product selection or product configuration.

You can find the TIA Selection Tool on the Internet.

(<https://support.industry.siemens.com/cs/ww/en/view/109767888>)

1.4.2 MultiFieldbus Configuration Tool (MFCT)

MultiFieldbus Configuration Tool

MultiFieldbus Configuration Tool (MFCT) is a PC-based software and supports the configuration of MultiFieldbus- and DALI-devices. In addition, the MFCT offers convenient options for mass firmware updates of ET 200 devices with MultiFieldbus- support and reading service data for many other Siemens devices.

Functional scope of the MFCT

- MultiFieldbus configuration:
Engineering, configuration and diagnostics of MultiFieldbus-devices, provision of the required project files (project, UDT-, CSV- and EDS-file), transfer/export of the files to device and/or data memory.
- DALI configuration:
Device selection and online configuration of DALI devices.
- TM FAST:
Generation and download of FPGA-UPD- and FPGA-DB-files.

- Maintenance:
Topology scan of a Ethernet network, reading of service data, parameter assignment and firmware update.
- Settings:
Language switching German / English, network scanner speed, setting of the network adapter, installation of GSDML-and EDS-files.

System/installation requirements for MFCT

The MFCT runs under Microsoft Windows and does not require installation or administrator rights.

For MFCT you must also install the following software:

- Microsoft .NET Framework 4.8 (You can find an Offline Installer on the Internet. (<https://support.microsoft.com/en-us/topic/microsoft-net-framework-4-8-offline-installer-for-windows-9d23f658-3b97-68ab-d013-aa3c3e7495e0>))
- NPcap from directory "Misc"
- PG/PC interface from directory "Misc"
- Microsoft C++ Redistributable for x86-systems (you can find the installation data for download on the Internet. (https://aka.ms/vs/15/release/vc_redist.x86.exe))

The download of the tool and further information as well as documentation on the individual functions of the MFCT can be found on the Internet.

(<https://support.industry.siemens.com/cs/de/en/view/109773881>)

1.4.3 SIMATIC Technical Documentation

Additional SIMATIC documents will complete your information. You can find these documents and their use at the following links and QR codes.

The Industry Online Support gives you the option to get information on all topics. Application examples support you in solving your automation tasks.

Overview of the SIMATIC Technical Documentation

Here you will find an overview of the SIMATIC documentation available in Siemens Industry Online Support:



Industry Online Support International

(<https://support.industry.siemens.com/cs/ww/en/view/109742705>)

Watch this short video to find out where you can find the overview directly in Siemens Industry Online Support and how to use Siemens Industry Online Support on your mobile device:



Quick introduction to the technical documentation of automation products per video (<https://support.industry.siemens.com/cs/us/en/view/109780491>)



YouTube video: Siemens Automation Products - Technical Documentation at a Glance (<https://youtu.be/TwLSxxRQsA>)

Retention of the documentation

Retain the documentation for later use.

For documentation provided in digital form:

1. Download the associated documentation after receiving your product and before initial installation/commissioning. Use the following download options:
 - Industry Online Support International: (<https://support.industry.siemens.com>)
The article number is used to assign the documentation to the product. The article number is specified on the product and on the packaging label. Products with new, non-compatible functions are provided with a new article number and documentation.
 - ID link:
Your product may have an ID link. The ID link is a QR code with a frame and a black frame corner at the bottom right. The ID link takes you to the digital nameplate of your product. Scan the QR code on the product or on the packaging label with a smartphone camera, barcode scanner, or reader app. Call up the ID link.
2. Retain this version of the documentation.

Updating the documentation

The documentation of the product is updated in digital form. In particular in the case of function extensions, the new performance features are provided in an updated version.

1. Download the current version as described above via the Industry Online Support or the ID link.
2. Also retain this version of the documentation.

mySupport

With "mySupport" you can get the most out of your Industry Online Support.

Registration	You must register once to use the full functionality of "mySupport". After registration, you can create filters, favorites and tabs in your personal workspace.
Support requests	Your data is already filled out in support requests, and you can get an overview of your current requests at any time.
Documentation	In the Documentation area you can build your personal library.
Favorites	You can use the "Add to mySupport favorites" to flag especially interesting or frequently needed content. Under "Favorites", you will find a list of your flagged entries.
Recently viewed articles	The most recently viewed pages in mySupport are available under "Recently viewed articles".
CAX data	The CAX data area gives you access to the latest product data for your CAX or CAE system. You configure your own download package with a few clicks: <ul style="list-style-type: none"> • Product images, 2D dimension drawings, 3D models, internal circuit diagrams, EPLAN macro files • Manuals, characteristics, operating manuals, certificates • Product master data

You can find "mySupport" on the Internet. (<https://support.industry.siemens.com/My/ww/en>)

Application examples

The application examples support you with various tools and examples for solving your automation tasks. Solutions are shown in interplay with multiple components in the system - separated from the focus on individual products.

You can find the application examples on the Internet. (<https://support.industry.siemens.com/cs/ww/en/ps/ae>)

Industrial Cybersecurity

2.1 Introduction to industrial cybersecurity

Due to the digitalization and increasing networking of machines and industrial plants, the risk of cyber attacks is also growing. Appropriate protective measures are therefore mandatory, particularly in the case of critical infrastructure facilities.

This section provides an overview of security-related information pertaining to your SIEMENS device.

2.2 Cybersecurity information

Siemens provides products and solutions with industrial cybersecurity functions that support the secure operation of plants, systems, machines and networks.

In order to protect plants, systems, machines and networks against cyber threats, it is necessary to implement – and continuously maintain – a holistic, state-of-the-art industrial cybersecurity concept. Siemens' products and solutions constitute one element of such a concept.

Customers are responsible for preventing unauthorized access to their plants, systems, machines and networks. Such systems, machines and components should only be connected to an enterprise network or the internet if and to the extent such a connection is necessary and only when appropriate security measures (e.g. firewalls and/or network segmentation) are in place.

For additional information on industrial cybersecurity measures that may be implemented, please visit <https://www.siemens.com/cybersecurity-industry>.

Siemens' products and solutions undergo continuous development to make them more secure. Siemens strongly recommends that product updates are applied as soon as they are available and that the latest product versions are used. Use of product versions that are no longer supported, and failure to apply the latest updates may increase customer's exposure to cyber threats.

To stay informed about product updates, subscribe to the Siemens Industrial Cybersecurity RSS Feed under <https://new.siemens.com/cert>.

2.3 Cybersecurity-relevant information

Observe all cybersecurity-relevant information.

Topics with cybersecurity-relevant information	Reference
Operational application environment and security assumptions	
Requirements for the operational application environment of the system and security assumptions	You can find this section in the System Manual (https://support.industry.siemens.com/cs/ww/en/view/109987776).
Security properties of the product	
Access protection	Note the information on access protection in the Protection chapter of the System Manual (https://support.industry.siemens.com/cs/ww/en/view/109987776).
Secure operation	
Recommendations for safe operation	You can find cross-system information on the safe operation of interface modules in the System Manual (https://support.industry.siemens.com/cs/ww/en/view/109987776).
Corrective measures for known risks	Corrective measures for known risks are announced on the Siemens ProductCERT and Siemens CERT (https://siemens.com/productcert) web page. You can find more information on SIEMENS ProductCERT in the System Manual (https://support.industry.siemens.com/cs/ww/en/view/109987776).
Security checks	You can find descriptions of specific security measures, such as cyclic checks of the configuration via checksums, in the Industrial cybersecurity section of the System Manual (https://support.industry.siemens.com/cs/ww/en/view/109987776).
Secure decommissioning Products that contain security-relevant data must be securely decommissioned before disposal or resale.	You can find information on secure decommissioning in the System Manual (https://support.industry.siemens.com/cs/ww/en/view/109987776), Secure operation of the system section

Product overview

3.1 Properties

Article number

6ES7155-8AR00-0AN0 (IM 155-8 PN interface module with end cover)

View of the module

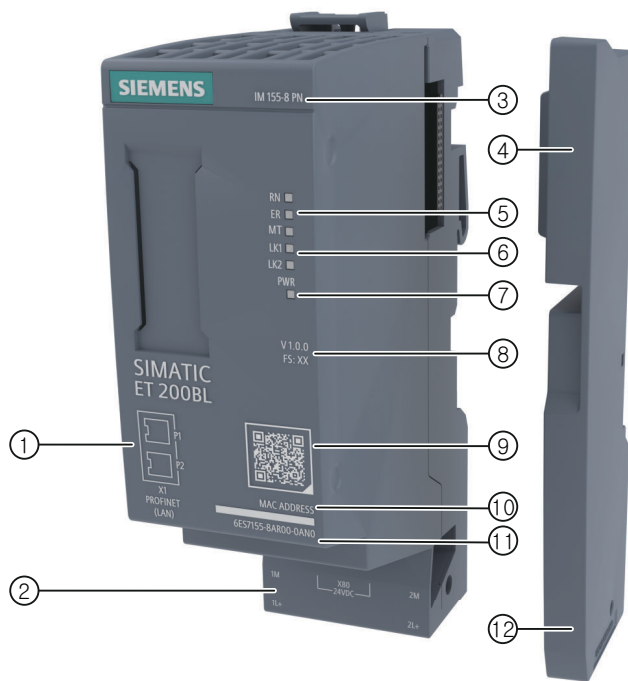

- | | | | |
|---|-----------------------------|---|--|
| ① | PROFINET connection | ⑦ | LED for supply voltage |
| ② | 24V DC power bus connection | ⑧ | Firmware version and function state |
| ③ | Module type and name | ⑨ | Identification Link |
| ④ | End cover | ⑩ | MAC address |
| ⑤ | LEDs for diagnostics | ⑪ | Article number of the interface module |
| ⑥ | LEDs for network status | ⑫ | Article number of the end cover |

Figure 3-1 View of the IM 155-8 PN interface module and the end cover

Properties

The module has the following properties:

- Technical properties
 - Connects the ET 200BL distributed I/O system with PROFINET IO
 - Supply voltage 1L+ 24 V DC (SELV/PELV). The end cover and the connection plug are included in the scope of delivery of the interface module.
- Supported functions ([Page 16](#))

Table 3-1 Version dependencies of the functions

Function	Function State (FS)	FW version	TIA Portal	MicroWin	Other engineering software with GSDML support (e.g. MFCT, TST)	GSD file (PROFINET IO)
Firmware update	01	V1.0.0 or higher	V18 or higher	V3.0 or higher	GSDML V2.45	X
I&M identification data	01	V1.0.0 or higher	V18 or higher	V3.0 or higher	GSDML V2.45	X
Parameter reassignment in RUN	01	V1.0.0 or higher	V18 or higher	V3.0 or higher	GSDML V2.45	X

Maximum configuration

- 16 I/O modules

Maximum amount of I/O data

Table 3-2 The maximum amount of I/O data

Features	Description
The maximum amount of address space per module	128 byte, per input/output
The maximum amount of address space per station	128 byte, per input/output

End cover

The end cover (article number: 6ES7193-8SE00-1AB0) is included in the scope of delivery of the interface module and also available separately as an accessory. The end cover is a plastic cover and used to close off the backplane bus of the ET 200BL.

Accessories and spare parts

The following accessories and spare parts can be ordered separately:

Table 3-3 Accessories and spare parts for the IM 155-8 PN interface module

Accessories and spare parts	Article number
24 V DC connector	6ES7193-4JB00-0AA0
Roll, light gray labeling strips	6ES7193-6LR10-0AA0
DIN A4 sheets, light gray labeling strips	6ES7193-6LA10-0AA0
Reference identification label	6ES7193-6LF30-0AW0
End cover bundle	6ES7193-8SE00-1AB0

A detailed list of the available accessories and spare parts can be found in the system manual ET 200BL distributed I/O system.

3.2 Functions

PROFINET IO

The interface module supports the following PROFINET IO functions:

- Integrated switch with 2 ports
- Supported Ethernet services: ICMP, ARP, SNMP, LLDP
- Port diagnostics
- Disabling of ports
- Isochronous real-time communication
- Minimum update time 1 ms
- Device replacement with topological configuration
- Reading out service data
- Reset to factory settings via PROFINET IO
- Firmware update via PROFINET IO

The interface module supports additional functions:

- Diagnostic alarms
- Identification data I&M 0 to 3

NOTE

Docking system

Do not use the IM 155-8 PN interface module as a docking station. The use as a docking unit (function: IO devices changing during operation) in a docking system is supported.

Requirements

Configuration takes place with GSDML (e.g. via STEP 7 V18).

Cabling with fixed connection setting

If you set a fixed connection setting of the port in STEP 7, you must also disable "Autonegotiation/Autocrossover".

For STEP 7 V18, you can find more information on this topic in the function manual "PROFINET with STEP 7 V18

(<https://support.industry.siemens.com/cs/ww/en/view/49948856>)".

Replacement of an IM 155-8 PN

In a replacement scenario, you could reset an IO device that is already in operation to its delivery state using "Reset to factory settings". Network parameters response to the project (device name, IP address, etc) needs to be configured.

You can find more information in the ET 200BL distributed I/O system manual.

3.2.1 Supported Ethernet services: ICMP, ARP, SNMP, LLDP

Supported Ethernet services: ICMP, ARP, SNMP, LLDP

The module supports the following standardized Ethernet services:

- **ICMP - Internet Control Message Protocol (RFC 792)**

ICMP is a protocol used to transmit informational and error messages over the Internet protocol.

- **ARP - Address Resolution Protocol (RFC 826)**

ARP is a protocol used to determine the hardware address (MAC) of an associated Internet Protocol (IP) address.

- **SNMP - Simple Network Monitoring Protocol (RFC 1157, RFC 3410)**

SNMP is a protocol for transmitting management information across networks.

- **LLDP – Link Layer Discovery Protocol (IEEE 802.1AB)**

LLDP is a protocol for identifying neighboring devices.

3.2.2 Port diagnostics

Port diagnostics

The device supports special diagnostics alarms that signal the quality of data transfer on the medium used.

3.2.3 Disabling of ports

Disabling of ports

The device supports the deactivation of the port by parameter assignment, so that all communication on this port is prevented.

3.2.4 Isochronous real-time communication

Synchronized transmission method for cyclic exchange of IRT data between PROFINET devices. A reserved bandwidth within the send clock is available for IRT data. The reserved bandwidth ensures that the IRT data is also transmitted in time-synchronized intervals, unaffected by other high network loading (e.g. TCP/IP communication or additional real time communication).

A topological configuration is required for IRT.

NOTE

IO controller as sync master with IRT communication

We recommend operating the IO controller also as a sync master when configuring the IRT communication.

Otherwise, IRT- and RT-configured IO devices may fail if the sync master fails.

You can find more information on the configuration of synchronized PROFINET devices in sync domains in the function manual PROFINET with STEP 7 V18 (<http://support.automation.siemens.com/WW/view/en/49948856>).

3.2.5 Minimum update time 1 ms

Minimum update time 1 ms

The shortest update cycle of IO data for this device is 1 ms. To achieve this value, the controller used must also support this time.

3.2.6 Device replacement with topological configuration

IO devices with this function can be replaced in a simple manner:

- The device name does not have to be assigned with the programming device.

The replacement IO device is assigned the device name by the IO controller and not by the programming device. The IO controller uses the configured topology and the neighboring relationships determined by the IO devices for this purpose. All involved devices must support the LLDP protocol (Link Layer Discovery Protocol). The configured target topology must match the actual topology.

If the IO devices were already used in another configuration, reset them to factory settings before reusing them. You can find information on this in the ET 200BL distributed I/O system manual.

You can find more information on this topic in the function manual PROFINET with STEP 7 V18 (<http://support.automation.siemens.com/WW/view/en/49948856>).

3.2.7 Reading out service data

Reading out service data

The function makes it possible to read out diagnostic and service information from the interface module.

In the case of a pending maintenance alarm, you can read out the service data and make it available to SIEMENS support for queries and product improvement.

The service data is read out using the TCP protocol. A connection on port 102 is opened for this.

Methods of reading service data

- Multi Fieldbus Configuration Tool (MFCT), V1.4.1 or higher

The download of the tool and additional information as well as documentation on the individual functions of the MFCT can be found on the Multi Fieldbus Configuration Tool (MFCT) (<https://support.industry.siemens.com/cs/de/de/view/109773881/en>).

3.2.8 Reset to factory settings via PROFINET IO

Reset to factory settings

Resetting to factory settings deletes the device name in the selected interface module. The device name in the interface module of other ET 200BL stations remains unchanged.

3.2.9 Firmware update via PROFINET IO

Firmware update via PROFINET IO

You can find information on how to perform a firmware update in the ET 200BL Distributed I/O system manual.

3.2.10 Identification data I&M 0 to I&M 3

Identification data I&M 0 to I&M 3

Identification and maintenance data (I&M data) is saved on the module. The data is:

- Read-only (I-data)
- Readable/writable (M-data)

Identification data (I&M0): Manufacturer information about the module that can only be read. Some identification data is also printed on the housing of the module, for example the article number and the serial number.

Maintenance data (I&M1, 2, 3): Plant-dependent information, e.g. installation location. Maintenance data is created during configuration and downloaded to the module. All modules of the ET 200BL distributed I/O system support identification data (I&M0 to I&M3).

The I&M identification data supports you in the following activities:

- Checking the system configuration
- Locating hardware changes in a plant
- Correcting faults in a plant
- Inspection of safe operation of a plant

Modules can be clearly identified online using the I&M identification data.

With TIA Portal, you can read out the identification data I&M (see online help of the TIA Portal).

You can find more information on the identification data I&M 0 to I&M 3 in the ET 200BL Distributed I/O System system manual.

Wiring

4.1 Terminal assignment

24 V DC supply voltage

The following table shows the signal names and the descriptions of the terminal assignment for a 24 V DC supply voltage.

Table 4-1 Terminal assignment 24 V DC supply voltage

View		Signal name ¹		Description
Connector	IM connection			
① 1L+		1	1L+	24 V DC
② 1M		2	1M	Ground
④ 2L+		3	2M	Ground (for looping through) ²
③ 2M		4	2L+	24 V DC (for looping through) ¹

¹ 1L+ and 2L+ as well as 1M and 2M are bridged internally.

² Maximum 10 A permitted.

PROFINET IO

The following table shows the signal name and description of the terminal assignment.

Table 4-2 PROFINET IO terminal assignment

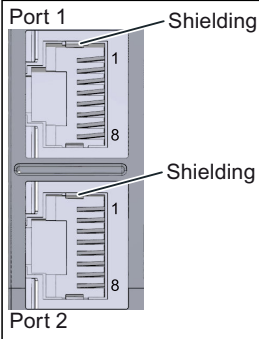
View	Signal name		Description
	1	TD	Transmit data +
	2	TD_N	Transmit data -
	3	RD	Receive data +
	4	TERM1	Terminal network 1
	5	TERM1	Terminal network 1
	6	RD_N	Receive data -
	7	TERM2	Terminal network 2
	8	TERM2	Terminal network 2

Reference

You can find more information on accessories and how to connect the interface module in the system manual ET 200BL distributed I/O system.

4.2 Wiring diagram

This section contains the pin assignment for the module.

This following figure shows an example of the wiring diagram of the interface module IM 155-8 PN.

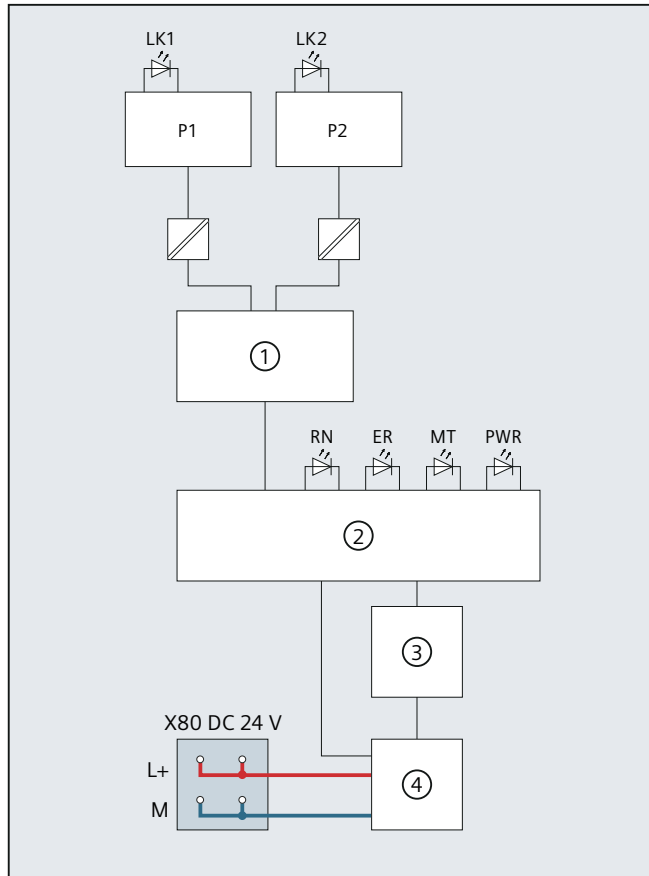

①	Switch	L+	24 V DC supply voltage
②	ET 200BL backplane bus interface and electronics	M	Ground
③	Backplane bus	LK 1, LK 2	Link TX/RX LED (green)
④	Internal power supply	RN	RUN LED (green)
X80 24 V DC	Supply voltage infeed	ER	ERROR LED (red)
P1	PROFINET interface X1 port 1	MT	MAINTENANCE LED (yellow)
P2	PROFINET interface X1 port 2	PWR	POWER LED (green)

Figure 4-1 Wiring diagram of IM 155-8 PN interface module

Interrupts, error messages, diagnostics and system alarms

5

5.1 Status and error displays

Introduction

Diagnostic by means of LEDs is an initial tool for error localization. In order to localize errors still further, you usually evaluate the display of the module status in STEP 7 or the diagnostics buffer of the CPU. The buffer contains plain text information on the error that has occurred. For example, you will find the number of the relevant error OB in the plain text information.

LED display

The following diagram shows the LED display on the interface module.

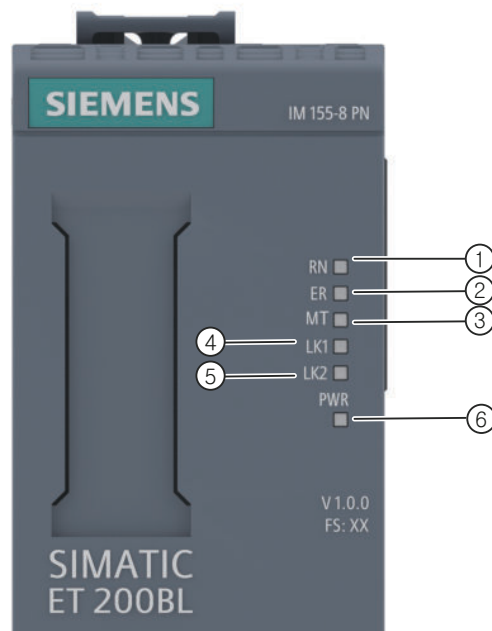

- ① RN (green)
- ② ER (red)
- ③ MT (yellow)
- ④ LK1 (green)
- ⑤ LK2 (green)
- ⑥ PWR (green)

Figure 5-1 LED display on the interface module

Meaning of the LEDs

The following tables describe the meanings of the status and error displays.

RN/ER/MT LED on the interface module

Table 5-1 RN/ER/MT status and error displays

LEDs			Meaning	Solution
RN (RUN)	ER (ERROR)	MT (MAINT)		
□ Off	□ Off	□ Off	No or insufficient supply voltage on interface module.	Check the supply voltage or turn it on at the interface module. *
■ On	■ On	■ On	Test of LEDs during startup: The three LEDs light up simultaneously for approximately 3 s.	-
☀ Flashes	Not relevant	Not relevant	Interface module is deactivated.	Activate the interface module with the configuration software or the user program.
			Interface module is not configured.	Configure the interface module with the configuration software.
			ET 200BL starts up.	-
			ET 200BL is being assigned parameters.	-
			ET 200BL is being reset to factory settings.	-
■ On	Not relevant	Not relevant	ET 200BL is currently exchanging data with the IO controller.	-
Not relevant	☀ Flashes	Not relevant	Module diagnostics is available.	Evaluate the diagnostics and eliminate the error.
			The preset configuration does not correspond to the actual configuration of the ET 200BL .	Check the structure of the ET 200BL to see whether a module is missing or defective, or whether a non-configured module is plugged.
			Invalid configuration states.	Refer to section Invalid configuration states of the ET 200BL on PROFINET IO (Page 30)
			Parameter error in the I/O module.	Evaluate the display of the module status in STEP 7 and eliminate the error in the respective I/O module.
Not relevant	Not relevant	■ On	Maintenance	Refer to section Maintenance events (Page 29)
☀ Flashes	☀ Flashes	☀ Flashes	The "Node flash test" is running (the LEDs LK1 and LK2 of the PROFINET interface also flash).	-
			Hardware or firmware defective (the LEDs LK1 and LK2 of the PROFINET interface do not flash).	Run a firmware update. If the error persists, contact Siemens Industry Online Support. Replace the interface module.

* PWR LED on (on the interface module): Check the backplane bus for a short circuit.

PWR LED on the interface module

Table 5-2 PWR status display on the interface module

PWR LED	Meaning	Solution
□ Off	No or insufficient supply voltage	Check the supply voltage.
■ On	Supply voltage present	-

LK1/LK2 LED on the interface module

Table 5-3 LK1/LK2 status display on the interface module

LEDs LK1/LK2	Meaning	Solution
□ Off	There is no Ethernet connection between the PROFINET IO interface of your PROFINET device and a communication partner (e.g. IO controller).	Check whether the bus cable to the switch/IO controller is interrupted.
■ On	There is an Ethernet connection between the PROFINET IO interface of your PROFINET device and a communication partner (e.g. IO controller).	-
⚡ Flashes	The "Node flash test" is running (the RN/ER/MT LEDs also flash).	-

LED display of configuration errors

Configuration errors of the ET 200BL distributed I/O system are output on the interface module by the ERROR (red) LED and the MAINT (yellow) LED

The following configuration errors are indicated by the LED:

- If more than one module is pulled out, the station stop might happen.
- Interruptions or short circuit on the backplane bus

Operating principle

You determine the information for cause of the error with the LED error display. After notification by the flash signal, the error type is displayed followed by the error location/error code.

The LED error display

- is active during POWER ON as well as during operation.
- has priority before all other states displayed by the ERROR LED (ER) and MAINT LED (MT).
- remains turned on until the cause of the error has been corrected.

Table 5-4 Display of error type and error location

Sequence	Description
1	The ERROR and MAINT LEDs flash 3x at 0.5 Hz Signaling of error type
2	MAINT LED flashes at 1 Hz Display of the error type (decimal)
3	The ERROR and MAINT LEDs flash 3x at 2 Hz Signaling of error location/error code

5.2 Interrupts

Sequence		Description
4	The ERROR LED flashes at 1 Hz	Display of tens digit (decimal) of the error location/error code
5	The MAINT LED flashes at 1 Hz	Display of ones digit (decimal) of the error location/error code
6	Repeat steps 1 to 5 until the cause of the error has been corrected.	

Error display

The following table shows the possible causes of error that can occur.

Table 5-5 Error display

Error type (MAINT)	Error location (ERROR/MAINT)	Cause of error	Remedy
1	02 to 16*	The number of pulled I/O modules is displayed. The diagnostics data is generated starting with two pulled I/O modules.	Check the configuration of the ET 200BL.

* Slot

5.2 Interrupts

Introduction

The I/O device generates interrupts as a reaction to specific error events. Interrupts are evaluated based on the I/O controller used.

Evaluating interrupts with I/O controllers

The ET 200BL distributed I/O system supports the following interrupts:

- Diagnostics interrupts
- Hardware interrupts
- Pull/plug module interrupts
- Maintenance events

In the event of an interrupt, interrupt OBs are automatically called in the CPU of the IO controller.

Information on the cause and class of the error is already available, based on the OB number and start information.

Detailed information on the error event can be obtained in the error OB using the instruction "RALRM" (read additional interrupt information).

System diagnostics

STEP 7 (TIA portal) offers innovative system diagnostics for the devices of the S7-1500 (IO controller CPU S7-1500) and the ET 200BL (IO device) automation system. Independent of the cyclic user program, alarms are made available on the display of the CPU S7-1500, the CPU web server and the HMI device.

For more information on system diagnostics, refer to the System Diagnostics function manual. (<http://support.automation.siemens.com/WW/view/en/59192926>).

5.2.1 Triggering a diagnostics interrupt

Triggering a diagnostics interrupt

For an incoming or outgoing event (e.g. wire break on a channel of an I/O module), the module triggers a diagnostics interrupt if this is configured accordingly.

The CPU interrupts the user program and processes the diagnostics block OB 82. The interrupt triggering event is logged in the start information of OB 82.

5.2.2 Triggering a hardware interrupt

Triggering a hardware interrupt

If there is a hardware interrupt, the CPU interrupts user program execution and processes the hardware interrupt block OB 40. The result that triggered the interrupt is added to the start information of the hardware interrupt block.

NOTE**Diagnostics "Hardware interrupt lost" (from I/O module)**

Avoid creating hardware interrupts cyclically.

If the hardware interrupt load is too high, hardware interrupts can get lost depending on the number of I/O modules and the communication load.

5.2.3 Triggering a pull/plug interrupt

Triggering a pull/plug interrupt

If there is a pull/plug interrupt, the CPU interrupts user program execution and processes the hardware interrupt block OB 83. The result that triggered the interrupt is added to the start information of OB 83.

5.3 Alarms

5.3.1 Diagnostics alarms

Actions after a diagnostics alarm

There can be more than one diagnostic alarm at a given time. Actions initiated by diagnostics alarms:

- The ERROR LED of the interface module flashes.
- Diagnostic data is reported as diagnostic interrupts to the CPU of the IO controller and can be read via data records.
- Incoming diagnostics alarms are saved to the diagnostics buffer of the I/O controller.
- OB 82 is called.

You can find more information on this topic in the STEP 7 online help.

Reading out the diagnostics data

Table 5-6 Reading the diagnostics with STEP 7

Automation system with IO controller	Application	See...
SIMATIC S7	Diagnostics as plain text in STEP 7 in online and diagnostics view	For STEP 7 V18, see the function manual "PROFINET with STEP 7".
	Instruction "RDREC" (SFB 52) Read data records from the IO device	
	Instruction "RALRM" (SFB 54) Receive interrupts from the IO device	

Additional information on the data records for PROFINET IO

The structure of the diagnostic data records and programming examples are available in the programming manual From PROFIBUS DP to PROFINET IO (<http://support.automation.siemens.com/WW/view/en/19289930>) and in Application example (<http://support.automation.siemens.com/WW/view/en/24000238>).

Causes of error and corrective measures

The causes of error and corrective measures for the diagnostics alarms are described in the manuals for I/O modules (<http://support.automation.siemens.com/WW/view/en/55679691/133300>) in the chapter, "Interrupts/diagnostics alarms".

5.3.2 Maintenance events

Triggering of a maintenance event

The PROFINET IO interfaces of the interface module support the diagnostic concept and maintenance concept in PROFINET IO according to the IEC 61158-6-10 standard. The goal is to detect and remove potential problems as soon as possible.

For the interface module, maintenance events signal to the user when a network component must be checked or replaced.

The CPU interrupts user program execution and processes the diagnostic block OB 82. The event that triggered the maintenance event is entered in the start information of the OB 82.

The interface module signals a maintenance event to the higher-level diagnostic system in the case of the following events:

Table 5-7 Triggering of a maintenance event

Maintenance alarm	Event	Meaning
Maintenance demanded (<i>maintenance demanded</i>) LED MAINT is lit.	Synchronization loss	<ul style="list-style-type: none"> No synchronization frame received No synchronization frame was received by the sync master within the timeout period after parameter assignment or during operation. Successive synchronization frames are located outside permitted limits (jitter)

System events in STEP 7 (TIA Portal)

The maintenance information is generated in STEP 7 with the following system events:

- Maintenance demanded - indicated for each port by a yellow wrench icon  in the device view or in the hardware configuration.

You can find more information in the STEP 7 online help.

5.3.3 Channel diagnostics

Function

Channel-related diagnostics provides information about channel faults in modules.

Channel faults are mapped as channel diagnostics data in IO diagnostics data records.

The data record is read using the instruction "RDREC".

Structure of the diagnostics data records

The data records supported by the ET 200BL distributed I/O system are based on the PROFINET IO standard - Application Layer Service Definition V2.2 or higher.

Coding of the extended channel diagnostics

With the IM 155-8 PN interface module, the following extended channel diagnostics are reported:

ChannelErrorType (CET)	ExtendedChannelError-Type (ECET)	Associated value AddValue	Diagnostics
0x0602	0x0692	Slot	Permitted number of I/O modules exceeded at slot.
0x0602	0x0694	0x02 to 0x10	More than one I/O module pulled. "Associated value Addvalue" is used to display the number of pulled I/O modules. Check the backplane bus connection.
0x0190	0x012C	Signed firmware version	The firmware has been loaded into the module. This firmware update takes effect after the interface module is restarted.
0x0190	0x0193	Signed firmware version	The firmware was not loaded into the module. This can be caused by many reasons, e.g. corrupted binary files or an incorrect signature.

5.3.4 Invalid configuration states of the ET 200BL on PROFINET IO

Invalid configuration states

The following invalid configuration states of the ET 200BL distributed I/O system lead to the failure of the IO device or prevent the exchange of user data with the I/O modules.

- Number of modules exceeds maximum configuration

NOTE

If you remove more than one I/O module, this results in a station stop. All I/O modules of the ET 200BL distributed I/O system fail (substitute value behavior) but the interface module is still exchanging data.

Revoking the station stop (by correcting the invalid configuration state) leads to a brief failure of the ET 200BL distributed I/O system and automatic recovery to the operation mode.

5.3.5 STOP of the IO controller and recovery of the IO device

STOP of the SIMATIC IO controller

Diagnostics frames received from the IO device while the IO controller is in STOP do not initiate a call of any corresponding OBs when the IO controller goes into RUN. You must read the data record E00C_H with the "RDREC" instruction in OB 100. This record contains all diagnostics for the slots assigned to an IO controller in an IO device.

Recovery of the SIMATIC IO device

If you want to read the diagnostics of a station after its return, you have to read the E00C_H data record with the "RDREC" instruction in OB 86. This record contains all diagnostics for the slots assigned to an IO controller in an IO device.

Technical specifications

Technical specifications of the IM 155-8 PN

The following table lists the technical specifications as of the issue date. You will find a data sheet including daily updated technical specifications on the Internet (<https://support.industry.siemens.com/cs/ww/en/pv/6ES7155-8AR00-0AN0/td?dl=en>).

Article number	6ES7155-8AR00-0AN0
General information	
Product type designation	IM 155-8 PN
HW functional status	from FS01
Firmware version	V1.0.0
<ul style="list-style-type: none"> FW update possible 	Yes
Vendor identification (VendorID)	0x002A
Device identifier (DeviceID)	0x031D
Product function	
<ul style="list-style-type: none"> I&M data 	Yes; I&M0 to I&M3
<ul style="list-style-type: none"> Module swapping during operation (hot swapping) 	No
<ul style="list-style-type: none"> Isochronous mode 	No
<ul style="list-style-type: none"> IRT 	Yes
Engineering with	
<ul style="list-style-type: none"> STEP 7 TIA Portal configurable/integrated from version 	STEP 7 V18 or higher; MicroWin V3.0 or higher; Configuration in ES via GSDML;
<ul style="list-style-type: none"> PROFINET from GSD version/GSD revision 	GSDML V2.45
Supply voltage	
Rated value (DC)	24 V
permissible range, lower limit (DC)	20.4 V
permissible range, upper limit (DC)	28.8 V
Reverse polarity protection	Yes
Short-circuit protection	Yes
Mains buffering	
<ul style="list-style-type: none"> Mains/voltage failure stored energy time 	5 ms
Input current	
Current consumption (rated value)	350 mA
Current consumption, max.	480 mA
Inrush current, max.	0.314 A
I^2t	0.00037 A ² ·s
Power loss	
Power loss, typ.	1.9 W

Article number	6ES7155-8AR00-0AN0
Address area	
Address space per module	
<ul style="list-style-type: none"> Address space per module, max. 	128 byte; For input and output data respectively
Address space per station	
<ul style="list-style-type: none"> Address space per station, max. 	128 byte; For input and output data respectively
Hardware configuration	
Rack	
<ul style="list-style-type: none"> number of modules per ET 200BL station, max. 	16
Interfaces	
Number of PROFINET interfaces	1; 2 ports (switch)
1. Interface	
Interface types	
<ul style="list-style-type: none"> RJ 45 (Ethernet) 	Yes; 2 integrated RJ45 ports
<ul style="list-style-type: none"> Number of ports 	2; integrated RJ45 ports
<ul style="list-style-type: none"> integrated switch 	Yes
<ul style="list-style-type: none"> BusAdapter (PROFINET) 	No
Protocols	
<ul style="list-style-type: none"> PROFINET IO Device 	Yes
<ul style="list-style-type: none"> PROFIBUS DP device 	No
<ul style="list-style-type: none"> Open IE communication 	Yes
<ul style="list-style-type: none"> Media redundancy 	No
PROFINET IO Device	
Services	
<ul style="list-style-type: none"> IRT 	Yes
<ul style="list-style-type: none"> PROFIenergy 	No
<ul style="list-style-type: none"> Shared device 	No
Interface types	
RJ 45 (Ethernet)	
<ul style="list-style-type: none"> Transmission procedure 	PROFINET with 100 Mbit/s full duplex (100BASE-TX)
<ul style="list-style-type: none"> 100 Mbps 	Yes
<ul style="list-style-type: none"> Autonegotiation 	Yes
<ul style="list-style-type: none"> Autocrossing 	Yes
Protocols	
Supports protocol for PROFINET IO	Yes
PROFIsafe	No
PROFIBUS	No
EtherNet/IP	No
Modbus TCP	No

Article number	6ES7155-8AR00-0AN0
Redundancy mode	
<ul style="list-style-type: none"> • PROFINET system redundancy (S2) 	No
Media redundancy	
<ul style="list-style-type: none"> – MRP 	No
<ul style="list-style-type: none"> – MRPD 	No
Open IE communication	
<ul style="list-style-type: none"> • TCP/IP 	Yes
<ul style="list-style-type: none"> • SNMP 	Yes
<ul style="list-style-type: none"> • LLDP 	Yes
Interrupts/diagnostics/status information	
Status indicator	Yes
Alarms	Yes
Diagnostics function	Yes
Diagnostics indication LED	
<ul style="list-style-type: none"> • RUN LED 	Yes; green LED
<ul style="list-style-type: none"> • ERROR LED 	Yes; red LED
<ul style="list-style-type: none"> • MAINT LED 	Yes; Yellow LED
<ul style="list-style-type: none"> • Monitoring of the supply voltage (PWR-LED) 	Yes; green PWR LED
<ul style="list-style-type: none"> • Connection display LINK TX/RX 	Yes; 2x green LED
Potential separation	
between backplane bus and electronics	No
between PROFINET and all other circuits	Yes; 1500 V AC (type test)
between supply and all other circuits	No
Isolation	
Isolation tested with	500 V AC/707 V DC, type test
Standards, approvals, certificates	
Network loading class	3
product functions / security / header	
PROFINET Security Class	1
signed firmware update	Yes
Secure Boot	Yes
safely removing data	Yes
Ambient conditions	
Ambient temperature during operation	
<ul style="list-style-type: none"> • horizontal installation, min. 	-30 °C
<ul style="list-style-type: none"> • horizontal installation, max. 	60 °C
<ul style="list-style-type: none"> • vertical installation, min. 	-30 °C
<ul style="list-style-type: none"> • vertical installation, max. 	50 °C

Article number	6ES7155-8AR00-0AN0
Altitude during operation relating to sea level	
<ul style="list-style-type: none"> • Installation altitude above sea level, max. 	5 000 m
Dimensions	
Width	35 mm
Height	117 mm
Depth	74 mm
Weights	
Weight, approx.	96 g

A

Dimension drawing

This appendix contains a dimension drawing of the module mounted on a mounting rail. Always observe the specified dimensions for installation in cabinets, control rooms, etc.

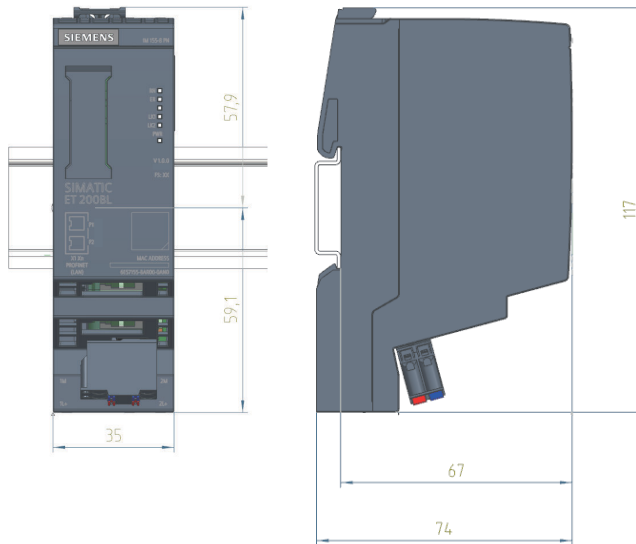

Figure A-1 Dimension drawing of the IM 155-8 PN interface module (front and side view)

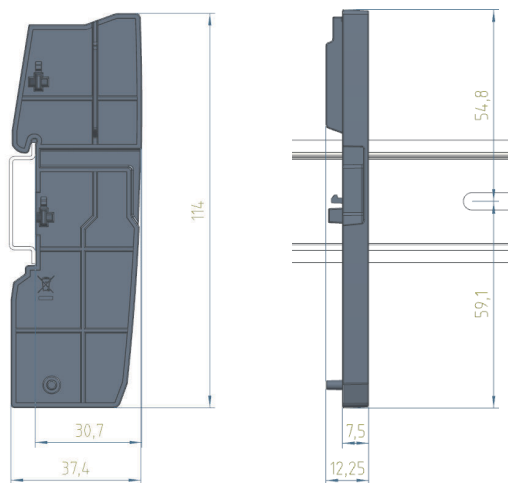

Figure A-2 Dimension drawing of the End Cover (front and side view)