

# SIEMENS

SIMATIC

ET 200SP

Analog input module  
AI 8xRTD/TC 2-wire HF  
(6ES7134-6JF00-0CA1)

Equipment Manual

Introduction

1

Industrial cybersecurity

2

Product overview

3

Wiring

4

Parameters/address space

5

Interrupts/diagnostics alarms

6

Technical specifications

7

Parameter data record

A



Representation of analog  
values

B

## Legal information

### Warning notice system

This manual contains notices you have to observe in order to ensure your personal safety, as well as to prevent damage to property. The notices referring to your personal safety are highlighted in the manual by a safety alert symbol, notices referring only to property damage have no safety alert symbol. These notices shown below are graded according to the degree of danger.

 <b>DANGER</b>
indicates that death or severe personal injury <b>will</b> result if proper precautions are not taken.
 <b>WARNING</b>
indicates that death or severe personal injury <b>may</b> result if proper precautions are not taken.
 <b>CAUTION</b>
indicates that minor personal injury can result if proper precautions are not taken.
<b>NOTICE</b>
indicates that property damage can result if proper precautions are not taken.

If more than one degree of danger is present, the warning notice representing the highest degree of danger will be used. A notice warning of injury to persons with a safety alert symbol may also include a warning relating to property damage.

### Qualified Personnel

The product/system described in this documentation may be operated only by **personnel qualified** for the specific task in accordance with the relevant documentation, in particular its warning notices and safety instructions. Qualified persons are those who, because of their training and experience, are familiar with the installation, assembly, commissioning, operation, decommissioning and disassembly of the product and can recognize risks and avoid possible hazards.

### Proper use of Siemens products

Note the following:

 <b>WARNING</b>
Siemens products may only be used for the application described in the catalog and the associated usage information. If products and components from other manufacturers are used, these must be recommended or approved by Siemens. Proper transport, storage, installation, assembly, commissioning, operation and maintenance are required to ensure that the products operate safely and without any problems. The permissible ambient conditions must be complied with. The information in the relevant documentation must be observed.

### Trademarks

All names identified by ® are registered trademarks of Siemens Aktiengesellschaft. The remaining trademarks in this publication may be trademarks whose use by third parties for their own purposes could violate the rights of the owner.

### Disclaimer of Liability

We have reviewed the contents of this publication to ensure consistency with the hardware and software described. Since variance cannot be precluded entirely, we cannot guarantee full consistency. However, the information in this publication is reviewed regularly and any necessary corrections are included in subsequent editions.

# Table of contents

<b>1</b>	<b>Introduction.....</b>	<b>5</b>
1.1	ET 200SP Documentation Guide.....	6
1.1.1	SIMATIC Technical Documentation.....	8
1.1.2	Tool support.....	10
1.1.3	Additional tools.....	12
1.1.3.1	MultiFieldbus Configuration Tool (MFCT).....	12
<b>2</b>	<b>Industrial cybersecurity.....</b>	<b>13</b>
2.1	Introduction to industrial cybersecurity.....	13
2.2	Cybersecurity information.....	13
2.3	Cybersecurity-relevant information.....	14
<b>3</b>	<b>Product overview.....</b>	<b>15</b>
3.1	Properties.....	15
<b>4</b>	<b>Wiring.....</b>	<b>18</b>
4.1	Connection diagram.....	18
4.2	System structure with BaseCarrier.....	20
4.3	Schematic circuit diagram.....	21
<b>5</b>	<b>Parameters/address space.....</b>	<b>22</b>
5.1	Measurement types and measuring ranges.....	22
5.2	Parameters.....	25
5.3	Explanation of parameters.....	30
5.4	Scalable measuring range.....	36
5.4.1	Configuration.....	38
5.4.2	Evaluating data record 235.....	39
5.5	Address space.....	41
<b>6</b>	<b>Interrupts/diagnostics alarms.....</b>	<b>47</b>
6.1	Status and error displays.....	47
6.2	Interrupts.....	49
6.2.1	Triggering of a diagnostics interrupt.....	49
6.2.2	Triggering a hardware interrupt.....	50
6.2.3	Triggering of a maintenance event.....	50
6.3	Alarms.....	50
6.3.1	Diagnostics alarms.....	51

6.3.2	Hardware interrupt messages.....	52
6.3.3	Maintenance alarms.....	53
<b>7</b>	<b>Technical specifications.....</b>	<b>55</b>
<b>A</b>	<b>Parameter data record.....</b>	<b>63</b>
A.1	Dependencies when configuring with GSD file.....	63
A.2	Parameter assignment and structure of parameter data record.....	67
A.3	Coding for measurement types.....	71
A.4	Coding for measuring ranges.....	72
A.5	Coding for temperature coefficient for temperature measurement.....	73
A.6	Limits for hardware interrupts.....	73
A.7	Errors when transferring the data record.....	75
A.8	Switchable wire break check.....	75
<b>B</b>	<b>Representation of analog values.....</b>	<b>77</b>
B.1	Measured values for wire break and reference channel mode.....	78
B.2	Representation of input ranges.....	79
B.3	Representation of analog values in voltage measuring ranges.....	80
B.4	Representation of analog values for resistance-type sensors.....	81
B.5	Representation of analog values for thermal resistors.....	82
B.6	Representation of analog values for thermocouples.....	84

# Introduction

## Purpose of the documentation

This manual supplements the ET 200SP distributed I/O system (<https://support.automation.siemens.com/WW/view/en/58649293>) system manual.

Functions that generally relate to the system are described in this system manual.

The information provided in this manual and in the system/function manuals supports you in commissioning the system.

## Changes compared to previous version

Compared to the previous version, this manual contains the following change:

- Wiring and block diagrams have been revised.
- Technical specifications have been updated.
- Security features have been added.

## Conventions

**CPU:** When the term "CPU" is used in the following, it applies to the CPUs of the S7-1500 automation system as well as to the CPUs/interface modules of the ET 200SP distributed I/O system.

**STEP 7:** In this documentation, "STEP 7" is used as a synonym for all versions of the configuration and programming software "STEP 7 (TIA Portal)".

Please also observe notes marked as follows:

---

### NOTE

A note contains important information on the product described in the documentation, on the handling of the product or on the section of the documentation to which particular attention should be paid.

---

## Recycling and disposal

For environmentally friendly recycling and disposal of your old equipment, contact a certified electronic waste disposal company and dispose of the equipment according to the applicable regulations in your country.

## 1.1 ET 200SP Documentation Guide



The documentation for the SIMATIC ET 200SP distributed I/O system is arranged into three areas.

This arrangement enables you to access the specific content you require.

You can download the documentation free of charge from the Internet (<https://support.industry.siemens.com/cs/ww/en/view/109742709>).

### Basic information



The System Manual describes in detail the configuration, installation, wiring and commissioning of the SIMATIC ET 200SP distributed I/O system.

The STEP 7 online help supports you in the configuration and programming.

Examples:

- ET 200SP System Manual
- System Manual ET 200SP HA/ET 200SP modules for devices used in a hazardous area
- Online help TIA Portal

### Device information



Equipment manuals contain a compact description of the module-specific information, such as properties, wiring diagrams, characteristics and technical specifications.

Examples:

- Equipment Manuals CPUs
- Equipment Manuals Interface Modules
- Equipment Manuals Digital Modules
- Equipment Manuals Analog Modules
- Equipment Manuals Motor Starter
- BaseUnits Equipment Manuals
- Equipment Manual Server Module
- Equipment Manuals Communications Modules
- Equipment Manuals Technology Modules

## General information



The function manuals contain detailed descriptions on general topics relating to the SIMATIC ET 200SP distributed I/O system.

Examples:

- Function Manual ET 200AL/ET 200SP Mixed Configuration
- Function Manual Diagnostics
- Function Manual Communication
- PROFINET Function Manual
- PROFIBUS Function Manual
- Function Manual Designing Interference-free Controllers
- MultiFieldbus Function Manual

## Product Information

Changes and supplements to the manuals are documented in a Product Information. The Product Information takes precedence over the device and system manuals.

You can find the latest Product Information on the ET 200SP distributed I/O system on the Internet. (<https://support.industry.siemens.com/cs/de/en/view/73021864>)

## Manual Collection ET 200SP

The Manual Collection contains the complete documentation on the SIMATIC ET 200SP distributed I/O system gathered together in one file.

You can find the Manual Collection on the Internet.

(<https://support.industry.siemens.com/cs/ww/en/view/84133942>)

## Manual Collection fail-safe modules

The Manual Collection contains the complete documentation on the fail-safe SIMATIC modules, gathered together in one file.

You can find the Manual Collection on the Internet.

### 1.1.1 SIMATIC Technical Documentation

Additional SIMATIC documents will complete your information. You can find these documents and their use at the following links and QR codes.

The Industry Online Support gives you the option to get information on all topics. Application examples support you in solving your automation tasks.

#### Overview of the SIMATIC Technical Documentation

Here you will find an overview of the SIMATIC documentation available in Siemens Industry Online Support:



Industry Online Support International  
(<https://support.industry.siemens.com/cs/ww/en/view/109742705>)

Watch this short video to find out where you can find the overview directly in Siemens Industry Online Support and how to use Siemens Industry Online Support on your mobile device:



Quick introduction to the technical documentation of automation products per video (<https://support.industry.siemens.com/cs/us/en/view/109780491>)



YouTube video: Siemens Automation Products - Technical Documentation at a Glance (<https://youtu.be/TwLSxxRQsA>)

#### Retention of the documentation

Retain the documentation for later use.

For documentation provided in digital form:

1. Download the associated documentation after receiving your product and before initial installation/commissioning. Use the following download options:
  - Industry Online Support International: (<https://support.industry.siemens.com>)  
The article number is used to assign the documentation to the product. The article number is specified on the product and on the packaging label. Products with new, non-compatible functions are provided with a new article number and documentation.
  - ID link:  
Your product may have an ID link. The ID link is a QR code with a frame and a black frame corner at the bottom right. The ID link takes you to the digital nameplate of your product. Scan the QR code on the product or on the packaging label with a smartphone camera, barcode scanner, or reader app. Call up the ID link.
2. Retain this version of the documentation.

## Updating the documentation

The documentation of the product is updated in digital form. In particular in the case of function extensions, the new performance features are provided in an updated version.

1. Download the current version as described above via the Industry Online Support or the ID link.
2. Also retain this version of the documentation.

## mySupport

With "mySupport" you can get the most out of your Industry Online Support.

<b>Registration</b>	You must register once to use the full functionality of "mySupport". After registration, you can create filters, favorites and tabs in your personal workspace.
<b>Support requests</b>	Your data is already filled out in support requests, and you can get an overview of your current requests at any time.
<b>Documentation</b>	In the Documentation area you can build your personal library.
<b>Favorites</b>	You can use the "Add to mySupport favorites" to flag especially interesting or frequently needed content. Under "Favorites", you will find a list of your flagged entries.
<b>Recently viewed articles</b>	The most recently viewed pages in mySupport are available under "Recently viewed articles".
<b>CAX data</b>	The CAX data area gives you access to the latest product data for your CAX or CAe system. You configure your own download package with a few clicks: <ul style="list-style-type: none"> <li>• Product images, 2D dimension drawings, 3D models, internal circuit diagrams, EPLAN macro files</li> <li>• Manuals, characteristics, operating manuals, certificates</li> <li>• Product master data</li> </ul>

You can find "mySupport" on the Internet. (<https://support.industry.siemens.com/My/ww/en>)

## Application examples

The application examples support you with various tools and examples for solving your automation tasks. Solutions are shown in interplay with multiple components in the system - separated from the focus on individual products.

You can find the application examples on the Internet. (<https://support.industry.siemens.com/cs/ww/en/ps/ae>)

## AI-powered online support chat

The "AskSUPPORT" function is an advanced AI-controlled platform that gives you access to the powerful knowledge base of the Siemens Support Portal (<https://sieportal.siemens.com/en-de/support>). You do not just receive mechanical answers to your questions, but precise, interactive informational material. This allows you to effectively speed up your research and decision processes.

The following link (<https://support.industry.siemens.com/cs/ww/en/view/109974274>) provides current information on the availability of AskSUPPORT:

You can also access the entry by means of the "AI powered Online Support Chat" command in the "Help" menu in TIA Portal.

## 1.1.2 Tool support

### Tools

The tools described below support you in all steps: from planning, over commissioning, all the way to analysis of your system.

#### TIA Selection Tool

The TIA Selection Tool tool supports you in the selection, configuration, and ordering of devices for Totally Integrated Automation (TIA).

As successor of the SIMATIC Selection Tools, the TIA Selection Tool assembles the already known configurators for automation technology into a single tool.

With the TIA Selection Tool, you can generate a complete order list from your product selection or product configuration.

You can find the TIA Selection Tool on the Internet.

(<https://support.industry.siemens.com/cs/ww/en/view/109767888>)

#### SIMATIC Automation Tool

You can use the SIMATIC Automation Tool to perform commissioning and maintenance activities on various SIMATIC S7 stations as bulk operations independent of TIA Portal.

The SIMATIC Automation Tool offers a wide range of functions:

- Scanning of a PROFINET/Ethernet system network and identification of all connected CPUs
- Assignment of addresses (IP, subnet, Gateway) and device name (PROFINET device) to a CPU
- Transfer of the date and the programming device/PC time converted to UTC time to the module
- Program download to CPU
- RUN/STOP mode switchover
- CPU localization through LED flashing
- Reading out of CPU error information
- Reading the CPU diagnostic buffer
- Reset to factory settings
- Firmware update of the CPU and connected modules

You can find the SIMATIC Automation Tool on the Internet.

(<https://support.industry.siemens.com/cs/ww/en/view/98161300>)

## PRONETA

SIEMENS PRONETA (PROFINET network analysis) is a commissioning and diagnostic tool for PROFINET networks. PRONETA Basic has two core functions:

- In the network analysis, you get an overview of the PROFINET topology. Compare a real configuration with a reference installation or make simple parameter changes, e.g. to the names and IP addresses of the devices.
- The "IO test" is a simple and rapid test of the wiring and the module configuration of a plant, including documentation of the test results.

You can find SIEMENS PRONETA Basic on the Internet:

(<https://support.industry.siemens.com/cs/ww/en/view/67460624>)

SIEMENS PRONETA Professional is a licensed product that offers you additional functions. It offers you simple asset management in PROFINET networks and supports operators of automation systems in automatic data collection/acquisition of the components used through various functions:

- The user interface (API) offers an access point to the automation cell to automate the scan functions using MQTT or a command line.
- With PROFlenergy diagnostics, you can quickly detect the current pause mode or the readiness for operation of devices that support PROFlenergy and change these as needed.
- The data record wizard supports PROFINET developers in reading and writing acyclic PROFINET data records quickly and easily without PLC and engineering.

You can find SIEMENS PRONETA Professional on the Internet.

(<https://www.siemens.com/proneta-professional>)

## SINETPLAN

SINETPLAN, the Siemens Network Planner, supports you in planning automation systems and networks based on PROFINET. The tool facilitates professional and predictive dimensioning of your PROFINET installation as early as in the planning stage. In addition, SINETPLAN supports you during network optimization and helps you to exploit network resources optimally and to plan reserves. This helps to prevent problems in commissioning or failures during productive operation even in advance of a planned operation. This increases the availability of the production plant and helps improve operational safety.

The advantages at a glance

- Network optimization thanks to port-specific calculation of the network load
- Increased production availability thanks to online scan and verification of existing systems
- Transparency before commissioning through importing and simulation of existing STEP 7 projects
- Efficiency through securing existing investments in the long term and the optimal use of resources

You can find SINETPLAN on the Internet

(<https://new.siemens.com/global/en/products/automation/industrial-communication/profinet/sinetplan.html>).

## 1.1.3 Additional tools

### 1.1.3.1 MultiFieldbus Configuration Tool (MFCT)

#### MultiFieldbus Configuration Tool

MultiFieldbus Configuration Tool (MFCT) is PC-based software and supports the configuration of MultiFieldbus-Devices and DALI-modules. In addition, the MFCT offers convenient options for bulk firmware updating of ET 200 devices with MultiFieldbus-support and reading of service data for many other Siemens devices.

##### Functional scope of the MFCT

- MultiFieldbus configuration:  
Engineering, configuration and diagnostics of MultiFieldbus-devices, provision of the required project files (project, UDT-, CSV- and EDS-file), transfer/export of the files to device and/or data memory.
- DALI configuration:  
Device selection and online configuration of DALI modules.
- TM FAST:  
Generation and download of FPGA-UPD- and FPGA-DB-files.
- Maintenance:  
Topology scan of a Ethernet network, reading of service data, parameter assignment and firmware update.
- Settings:  
Language switching German / English, network scanner speed, setting of the network adapter, installation of GSDML-and EDS-files.

##### System/installation requirements for MFCT

The MFCT runs under Microsoft Windows and does not require installation or administrator rights.

For MFCT you must also install the following software:

- Microsoft .NET Framework 4.8 (You can find an Offline Installer on the Internet. (<https://support.microsoft.com/en-us/topic/microsoft-net-framework-4-8-offline-installer-for-windows-9d23f658-3b97-68ab-d013-aa3c3e7495e0>))
- Npcap from directory "Misc"
- PG/PC interface from directory "Misc"
- Microsoft C++ Redistributable for x86-systems (you can find the installation data for download on the Internet. ([https://aka.ms/vs/15/release/vc\\_redist.x86.exe](https://aka.ms/vs/15/release/vc_redist.x86.exe)))

The download of the tool and further information as well as documentation on the individual functions of the MFCT can be found on the Internet.

(<https://support.industry.siemens.com/cs/ww/en/view/109773881>)

# Industrial cybersecurity

## 2.1 Introduction to industrial cybersecurity

Digitalization and the increasing networking of machines and industrial plants are also increasing the risk of cyberattacks. Appropriate protective measures are therefore mandatory, particularly in the case of critical infrastructure facilities.

Refer to the general information and measures on the subject of industrial cybersecurity in the ET 200SP Distributed I/O System

(<https://support.industry.siemens.com/cs/ww/en/view/58649293>) System Manual.

This section provides an overview of security-relevant information pertaining to your SIEMENS device.

## 2.2 Cybersecurity information

Siemens provides products and solutions with industrial cybersecurity functions that support the secure operation of plants, systems, machines and networks.

In order to protect plants, systems, machines and networks against cyber threats, it is necessary to implement – and continuously maintain – a holistic, state-of-the-art industrial cybersecurity concept. Siemens' products and solutions constitute one element of such a concept.

Customers are responsible for preventing unauthorized access to their plants, systems, machines and networks. Such systems, machines and components should only be connected to an enterprise network or the internet if and to the extent such a connection is necessary and only when appropriate security measures (e.g. firewalls and/or network segmentation) are in place.

For additional information on industrial cybersecurity measures that may be implemented, please visit

<https://www.siemens.com/cybersecurity-industry>.

Siemens' products and solutions undergo continuous development to make them more secure. Siemens strongly recommends that product updates are applied as soon as they are available and that the latest product versions are used. Use of product versions that are no longer supported, and failure to apply the latest updates may increase customer's exposure to cyber threats.

To stay informed about product updates, subscribe to the Siemens Industrial Cybersecurity RSS Feed under

<https://www.siemens.com/cert>.

## 2.3 Cybersecurity-relevant information

Observe all relevant cybersecurity information.

You can find the supported security functions of the module in the Technical Specifications (Page 55) under "Security". The functions are described in detail in the section on industrial cybersecurity in the system manual (<https://support.industry.siemens.com/cs/ww/en/view/58649293>).

## Product overview

### 3.1 Properties

#### Article number

- 6ES7134-6JF00-0CA1 (packing unit: 1 unit)
- 6ES7134-6JF00-2CA1 (packing unit: 10 units)

#### View of the module

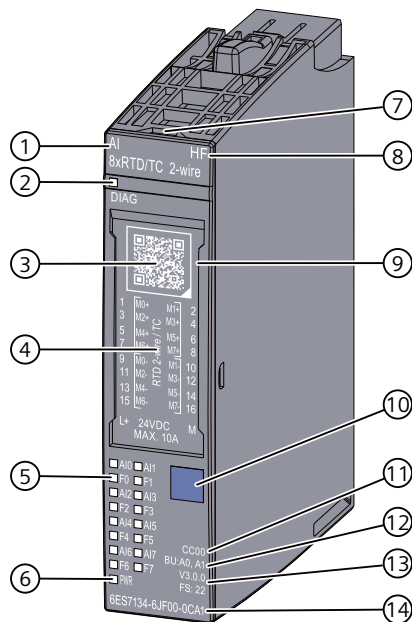

- |  |  |
|--|--|
| ① Module type and name                       | ⑧ Function class   |
| ② LED for diagnostics                        | ⑨ Insertion option for optional labeling strips            |
| ③ QR code for identification link            | ⑩ Color coding module type                                 |
| ④ Wiring diagram                             | ⑪ Color code for selecting the color identification labels |
| ⑤ LEDs for channel status and channel fault  | ⑫ BU type  |
| ⑥ LED for supply voltage                     | ⑬ Firmware revision level and release number               |
| ⑦ Slot for optional equipment labeling plate | ⑭ Article number   |

Figure 3-1 View of the AI 8xRTD/TC 2-wire HF module

## Properties

The module has the following technical properties:

- Analog input module with 8 inputs
- 4 measurement types, can be set per channel
  - Thermal resistor (RTD)
  - Thermocouple (TC)
  - Resistor
  - Voltage
- Resolution: Up to 16 bits including sign
  - Can be extended to max. 3 decimal places via the scalable measuring range for the measuring types RTD and TC.
- Configurable diagnostics (per channel)
- Hardware interrupt on limit violation can be set (two high and two low limits per channel)
- Adjustable compensation
  - RTD: Compensation of the line resistance for a 2-wire connection
  - TC: external or internal temperature compensation
- interference frequency suppression, adjustable

The module supports the following functions:

Table 3-1 Version dependencies of the functions

Function	HW version	FW version	STEP 7		GSD file	
			TIA Portal	V5.x	PROFINET IO	PROFIBUS DP
Firmware update	FS01	As of V2.0.0	As of V13	As of V5.5 SP3 with HSP 0227 as of V3.0	X	X
Identification data I&M0 to I&M3	FS01	As of V2.0.0	As of V13	As of V5.5 SP3 with HSP 0227 as of V3.0	X	X
Reconfiguration in RUN	FS01	As of V2.0.0	As of V13	As of V5.5 SP3 with HSP 0227 as of V3.0	X	X
Value status (PROFINET IO only)	FS01	As of V2.0.0	As of V13	As of V5.5 SP3 with HSP 0227 as of V3.0	X	X
Calibration in runtime	FS01	As of V2.0.0	As of V13	As of V5.5 SP3 with HSP 0227 as of V3.0	X	X
Scalable measuring range	FS01	As of V2.0.0	As of V13	As of V5.5 SP3 with HSP 0227 as of V2.0	X	X <sup>1</sup>
Configurable conductor resistance	FS01	As of V2.0.0	As of V13	As of V5.5 SP3 with HSP 0227 as of V3.0	X	X <sup>1</sup>

<sup>1</sup> Due to the limited number of parameters of a maximum of 244 bytes per ET 200SP station with a PROFIBUS GSD configuration, the configuration options are restricted. The parameter can only be parameterized later via data record 128.

Function	HW version	FW version	STEP 7		GSD file	
			TIA Portal	V5.x	PROFINET IO	PROFIBUS DP
Switchable wire-break check	FS01	As of V2.0.0	As of V13	As of V5.5 SP3 with HSP 0227 as of V3.0	X	X
Extended interference frequency suppression <ul style="list-style-type: none"> <li>• 60 Hz (18.75 ms)</li> <li>• 50 Hz (22.5 ms)</li> <li>• 16.6 Hz (67.5 ms)</li> </ul>	FS01	As of V2.1.0	As of V16 with HSP 0357	As of V5.5 SP3 with HSP0227 as of V12.0	X	X <sup>1</sup>
Module-internal shared input (MSI)	FS22	As of V3.0.0	As of V21 with HSP 0495	As of V5.7 SP3 HF3 with HSP0348 V2.0	X	-

<sup>1</sup> Due to the limited number of parameters of a maximum of 244 bytes per ET 200SP station with a PROFIBUS GSD configuration, the configuration options are restricted. The parameter can only be parameterized later via data record 128.

## Accessories

The following accessories must be ordered separately:

- Labeling strips
- Color identification labels
- Equipment labeling plate
- Shield connection

## See also

You can find additional information on the accessories in the ET 200SP distributed I/O system (<http://support.automation.siemens.com/WW/view/en/58649293>) system manual.

## Wiring

### 4.1 Connection diagram

This section contains the pin assignments of the module and the various connection types. You can find information on wiring the BaseUnit in the ET 200SP distributed I/O system (<http://support.automation.siemens.com/WW/view/en/58649293>) system manual.

---

#### NOTE

- The load group of the module must begin with a light-colored BaseUnit. Keep this in mind also during the configuration.
- When using floating sensors, bridge the m- connections and connect to ground / FE. This increases the immunity of the module.

Bridging and connecting are not necessary for disabled and disconnected inputs.

---



---

#### NOTE

##### Compensation of the conductor resistance for RTD or resistance measurement

For compensation of the conductor resistance, a fixed value for the parasitic conductor resistance of the entire measuring loop can be entered via the corresponding parameter.

---

### Pin assignment

The following table shows an example of the pin assignment of the analog input module on the BaseUnit BU type A0/A1:

Description	Signal	Terminal	BaseUnit BU type A0/A1	Terminal	Signal	Description
Measurement cable positive, channel 0	M <sub>0+</sub>	1		2	M <sub>1+</sub>	Measurement cable positive, channel 1
Measurement cable positive, channel 2	M <sub>2+</sub>	3		4	M <sub>3+</sub>	Measurement cable positive, channel 3
Measurement cable positive, channel 4	M <sub>4+</sub>	5		6	M <sub>5+</sub>	Measurement cable positive, channel 5
Measurement cable positive, channel 6	M <sub>6+</sub>	7		8	M <sub>7+</sub>	Measurement cable positive, channel 7
Measurement cable negative, channel 0	M <sub>0-</sub>	9		10	M <sub>1-</sub>	Measurement cable negative, channel 1
Measurement cable negative, channel 2	M <sub>2-</sub>	11		12	M <sub>3-</sub>	Measurement cable negative, channel 3

<sup>1)</sup> Infeed only with light-colored BaseUnit

Description	Signal	Terminal	BaseUnit BU type A0/A1	Terminal	Signal	Description	
Measurement cable negative, channel 4	M <sub>4</sub> -	13		14	M <sub>5</sub> -	Measurement cable negative, channel 5	
Measurement cable negative, channel 6	M <sub>6</sub> -	15		16	M <sub>7</sub> -	Measurement cable negative, channel 7	
24 V DC supply voltage <sup>1)</sup>	L+	L+		7	M	M	Ground
				9			
				11			
				13			
				15			
			L+				

<sup>1)</sup> Infeed only with light-colored BaseUnit

### Connection types

Linear resistance or resistance temperature detectors (RTD)	Thermocouples/voltage
2-wire connection	2-wire connection

## 4.2 System structure with BaseCarrier

The figure below shows the pinning of the PCB connector of the BaseCarrier in top view.

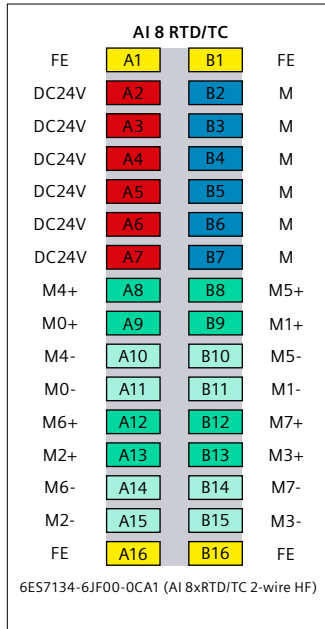

Figure 4-1 Pinning AI 8xRTD/TC 2-wire HF

You can find more information in the ET 200SP System Structure with BaseCarrier (<https://support.industry.siemens.com/cs/ww/en/view/109988377>) function manual

### 4.3 Schematic circuit diagram

This section contains the schematic circuit diagram of the analog input module.

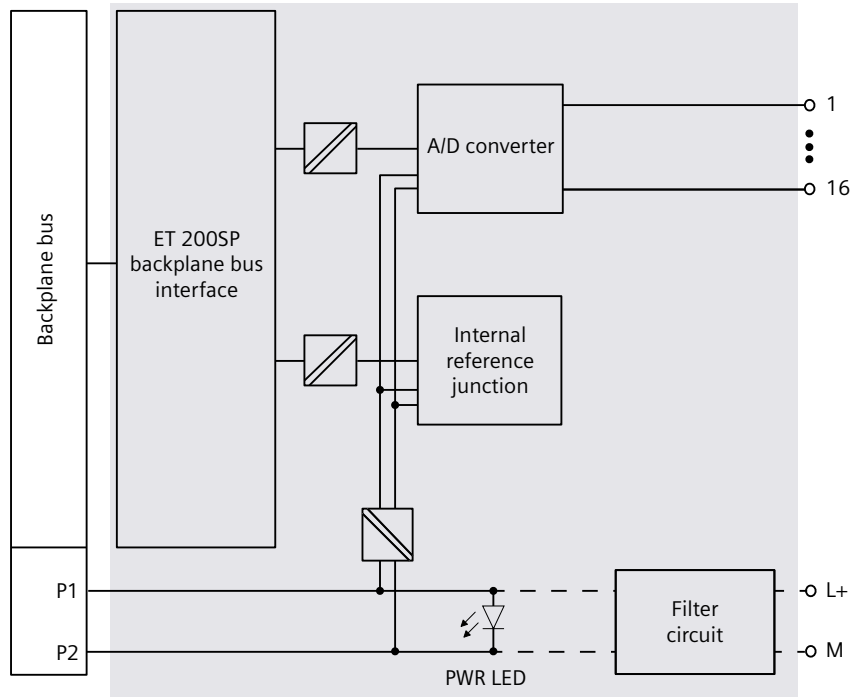

Figure 4-2 Circuit diagram AI 8xRTD/TC 2-wire HF

## Parameters/address space

### 5.1 Measurement types and measuring ranges

The following table describes the measuring range and the temperature coefficients you can configure for each measurement type:

Table 5-1 Measurement types and measuring ranges

Measurement type	Measuring range	Temperature coefficient
Disabled	–	–
Voltage	±50 mV / ±80 mV / ±250 mV / ±1 V	
Resistor (2-wire connection)	150 Ω / 300 Ω / 600 Ω / 3 kΩ / 6 kΩ	–
	PTC	-
Thermal resistor RTD (2-wire connection)	Climatic / Standard Pt 100 Pt 200 Pt 500 Pt 1000	Pt 0.00385 / Pt 0.003916 / Pt 0.003902 / Pt 0.00392 / Pt 0.00385055
	Climatic / Standard Ni 100 Ni 120 Ni 200 Ni 500 Ni 1000	Ni 0.00618 / Ni 0.00672
	Climatic <sup>1</sup> / Standard <sup>1</sup> Ni 1000	Ni 0.005
Thermocouple (TC)	Type E, N, J, K, L, S, R, B, T, C, U, TXX (acc. to GOST)	-

<sup>1</sup> For sensors LG-Ni 1000 from Siemens Building Ltd (Landis & Stäfa).

## Special features when using PTC resistors

PTCs are suitable for monitoring temperature and as thermal protection devices for complex drives or transformer windings.

- Choose "Resistor (2-wire)" and "PTC" in the parameter assignment.
- Connect the PTC to the 2-wire connection technology.
- Use the PTC resistors, type A (PTC thermistor) in accordance with DIN/VDE 0660, part 302.
- If "Underflow" diagnostics is enabled, a "Violation of low limit" diagnostics is generated for resistance values  $< 18 \Omega$ , indicating a short-circuit.
- Sensor data for the PTC resistor:

Table 5-2 Using PTC resistors

Property	Technical specifications	Comment
Switching points	<b>Behavior with rising temperature</b>	
	$< 550 \Omega$	<b>Normal range:</b> • SIMATIC S7: Bit 0 = "0", Bit 2 = "0" (in the PII)
	550 $\Omega$ to 1650 $\Omega$	<b>Prewarning range:</b> • SIMATIC S7: Bit 0 = "0", Bit 2 = "1" (in the PII)
	$> 1650 \Omega$	<b>Response range:</b> • SIMATIC S7: Bit 0 = "1", Bit 2 = "0" (in the PII)
	<b>Behavior with falling temperature</b>	
	$> 750 \Omega$	<b>Response range:</b> • SIMATIC S7: Bit 0 = "1", Bit 2 = "0" (in the PII)
	750 $\Omega$ to 540 $\Omega$	<b>Prewarning range:</b> • SIMATIC S7: Bit 0 = "0", Bit 2 = "1" (in the PII)
	$< 540 \Omega$	<b>Normal range:</b> • SIMATIC S7: Bit 0 = "0", Bit 2 = "0" (in the PII)
	<b>Reaction to short-circuit</b>	
	$< 18 \Omega$	• SIMATIC S7: Bit 7 (IB x+1) = "1", Bit 0 = "0" and Bit 2 = "0"
(RRT-5) °C (RRT+5) °C (RRT+15) °C Measuring voltage/ voltage at the PTC	Max. 550 $\Omega$ min. 1330 $\Omega$ min. 4000 $\Omega$ Max. 7.5 V <sup>1</sup>	TNF = Rated response temperature of the sensor (according to DIN/VDE 0660)

<sup>1</sup> Below 23 k $\Omega$

**Assignment in the process image of the inputs (PII) with SIMATIC S7**

Table 5-3 Assignment in the process image of the inputs (PII) with SIMATIC S7

Bit →	Bit 7	Bit 6	Bit 5	Bit 4	Bit 3	Bit 2	Bit 1	Bit 0
Byte ↓								
IB x	0 <sub>B</sub> : No short-circuit 1 <sub>B</sub> : Short-circuit	Reserved <sup>1</sup>						
IB x+1	Reserved <sup>1</sup>					Measured temperature 0 <sub>B</sub> : outside prewarning range 1 <sub>B</sub> : in pre-warning range	Reserved <sup>1</sup>	Measured temperature 0 <sub>B</sub> : below actuating range 1 <sub>B</sub> : in actuating range

<sup>1</sup> Reserved bits must be set to 0

**Notes on programming**

- Bits 0+2 are relevant for evaluation in the process image of the inputs. You can monitor, for example, the temperature of a motor using bits 0+2.
- Bits 0+2 in the process image of the inputs cannot be saved. During parameter assignment, take into consideration that a motor, for example, starts up in a controlled manner (via an acknowledgment).
- Bits 0+2 can never be set at the same time; they are set one after the other.

**NOTICE****No measurement is possible in the following cases:**

- When I/O modules are pulled out
- When supply voltage to the I/O module fails
- When there is a wire break or short-circuit in the measuring lines

You should therefore always evaluate the diagnostic entries of AI 8×RTD/TC 2-wire HF for safety reasons.

## Example

The diagram shows the temperature curve and the associated switching points.

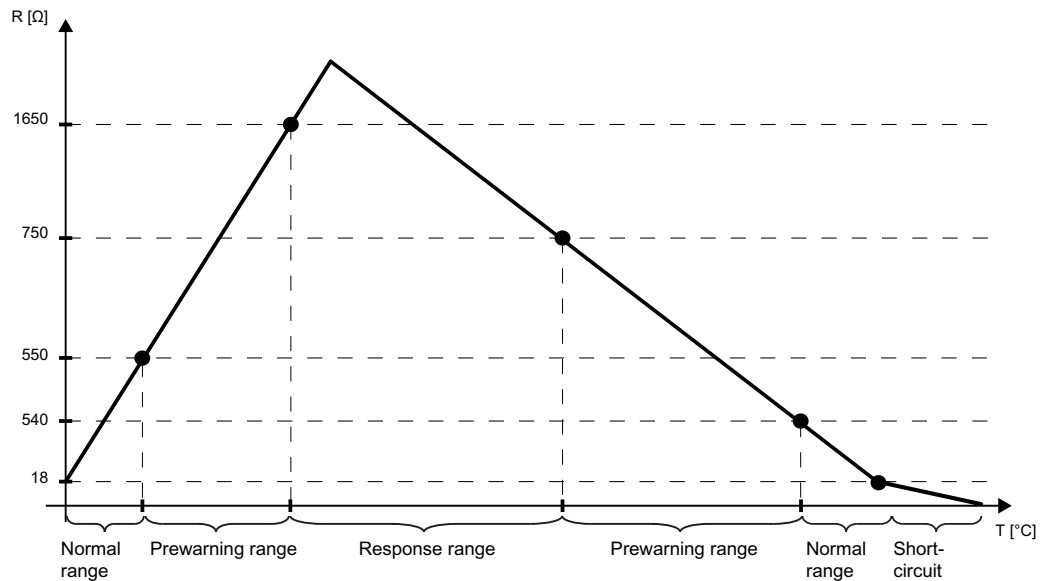

Figure 5-1 Temperature curve with prewarning range

## See also

[Technical specifications \(Page 55\)](#)

## 5.2 Parameters

### Parameters of the AI 8xRTD/TC 2-wire HF

Specify the module properties with the various parameters in the course of your STEP 7 configuration. The following table lists the configurable parameters. The effective range of the configurable parameters depends on the type of configuration.

The following configurations are possible:

- Central operation on an ET 200SP CPU or on an ET 200SP Open Controller
- Distributed operation on PROFINET IO in an ET 200SP system
- Distributed operation with PROFIBUS DP in an ET 200SP system

In addition to assigning parameters with the configuration software, you can also set the parameters in RUN mode (dynamically) using the user program. When assigning parameters in the user program, use the "WRREC" instruction to transfer the parameters to the module using the data records; see section Parameter assignment and structure of parameter data record ([Page 67](#)).

## 5.2 Parameters

The following parameter settings are possible:

Table 5-4 Configurable parameters and their defaults (GSD file)

Parameters	Value range	Default	Reconfigura- tion in RUN	Scope with configuration software e.g. STEP 7 (TIA Portal)	
				GSD file PROFINET IO	GSD file PROFIBUS DP
Diagnostics: Missing supply voltage L+	<ul style="list-style-type: none"> <li>• Disable</li> <li>• Enable</li> </ul>	Disable	Yes	Channel	Channel
Diagnostics: Reference junction	<ul style="list-style-type: none"> <li>• Disable</li> <li>• Enable</li> </ul>	Disable	Yes	Channel	Module
Diagnostics: Overflow	<ul style="list-style-type: none"> <li>• Disable</li> <li>• Enable</li> </ul>	Disable	Yes	Channel	Module
Diagnostics: Underflow	<ul style="list-style-type: none"> <li>• Disable</li> <li>• Enable</li> </ul>	Disable	Yes	Channel	
Diagnostics: Wire break	<ul style="list-style-type: none"> <li>• Disable</li> <li>• Enable</li> </ul>	Disable	Yes	Channel	Channel
Type/range of meas- urement	<ul style="list-style-type: none"> <li>• Disabled</li> </ul>	Thermal resistor (2-wire connection) Pt 100 standard range	Yes	Channel	Channel
	<ul style="list-style-type: none"> <li>• Voltage <math>\pm 50</math> mV</li> <li>• Voltage <math>\pm 80</math> mV</li> <li>• Voltage <math>\pm 250</math> mV</li> <li>• Voltage <math>\pm 1</math> V</li> </ul>				
	Resistor (2-wire connection) <ul style="list-style-type: none"> <li>• 150 <math>\Omega</math></li> <li>• 300 <math>\Omega</math></li> <li>• 600 <math>\Omega</math></li> <li>• 3 k<math>\Omega</math></li> <li>• 6 k<math>\Omega</math></li> </ul>				
	Resistor (2-wire connection) PTC		Yes	Channel	Channel

- <sup>1</sup> Interference frequency suppression: Interfering signals at 400 Hz are automatically included in the filtering at 50 Hz.
- <sup>2</sup> The settings in the "Interference frequency suppression" parameter have a direct effect on the conversion time of the channel. The analog value is therefore also affected by additionally set filtering via the "Smoothing" parameter.
- <sup>3</sup> Due to the limited number of parameters of a maximum of 244 bytes per ET 200SP station with a PROFIBUS GSD configuration, the parameter assignment options are restricted. The parameter length of the I/O module is 24 bytes with PROFIBUS GSD configuration. However, if necessary you can set these parameters using data records 0 to 7 or data record 128, see appendix "Parameter data record".
- <sup>4</sup> Only for configuration with PROFIBUS GSD file: The set reference junction is used with the additional parameter "Kx Reference junction activated" in the case of "Enable". In the case of "Disable", "No reference channel mode" is used for RTD and "Fixed reference temperature" is used for TC.
- <sup>5</sup> Thermocouple types B and C are not suitable for reference junction temperatures below 0 °C on account of their defined characteristic curve as of 0 °C.
- <sup>6</sup> By selecting this interference frequency suppression with shorter integration time, the attenuation of the interference frequency that can be achieved is reduced (see Technical Specifications).

Parameters	Value range	Default	Reconfiguration in RUN	Scope with configuration software e.g. STEP 7 (TIA Portal)	
				GSD file PROFINET IO	GSD file PROFIBUS DP
Type/range of measurement	Thermal resistor (2-wire connection) <ul style="list-style-type: none"> <li>Pt 100 climatic range</li> <li>Pt 200 climatic range</li> <li>Pt 500 climatic range</li> <li>Pt 1000 climatic range</li> </ul>	Thermal resistor (2-wire connection) Pt 100 standard range	Yes	Channel	Channel
	Thermal resistor (2-wire connection) <ul style="list-style-type: none"> <li>Pt 100 standard range</li> <li>Pt 200 standard range</li> <li>Pt 500 standard range</li> <li>Pt 1000 standard range</li> </ul>				
	Thermal resistor (2-wire connection) <ul style="list-style-type: none"> <li>Ni 100 climatic range</li> <li>Ni 120 climatic range</li> <li>Ni 200 climatic range</li> <li>Ni 500 climatic range</li> <li>Ni 1000 climatic range</li> </ul>		Yes	Channel	Channel
	Thermal resistor (2-wire connection) <ul style="list-style-type: none"> <li>Ni 100 standard range</li> <li>Ni 120 standard range</li> <li>Ni 200 standard range</li> <li>Ni 500 standard range</li> <li>Ni 1000 standard range</li> </ul>				
	Thermocouple <ul style="list-style-type: none"> <li>Type B (PtRh-PtRh)</li> <li>Type N (NiCrSi-NiSi)</li> <li>Type E (NiCr-CuNi)</li> <li>Type R (PtRh-Pt)</li> <li>Type S (PtRh-Pt)</li> <li>Type J (Fe-CuNi)</li> <li>Type L (Fe-CuNi)</li> <li>Type T (Cu-CuNi)</li> <li>Type K (NiCr-NiAl)</li> <li>Type U (Cu-CuNi)</li> </ul>		Yes	Channel	Channel

- Interference frequency suppression: Interfering signals at 400 Hz are automatically included in the filtering at 50 Hz.
- The settings in the "Interference frequency suppression" parameter have a direct effect on the conversion time of the channel. The analog value is therefore also affected by additionally set filtering via the "Smoothing" parameter.
- Due to the limited number of parameters of a maximum of 244 bytes per ET 200SP station with a PROFIBUS GSD configuration, the parameter assignment options are restricted. The parameter length of the I/O module is 24 bytes with PROFIBUS GSD configuration. However, if necessary you can set these parameters using data records 0 to 7 or data record 128, see appendix "Parameter data record".
- Only for configuration with PROFIBUS GSD file: The set reference junction is used with the additional parameter "Kx Reference junction activated" in the case of "Enable". In the case of "Disable", "No reference channel mode" is used for RTD and "Fixed reference temperature" is used for TC.
- Thermocouple types B and C are not suitable for reference junction temperatures below 0 °C on account of their defined characteristic curve as of 0 °C.
- By selecting this interference frequency suppression with shorter integration time, the attenuation of the interference frequency that can be achieved is reduced (see Technical Specifications).

## 5.2 Parameters

Parameters	Value range	Default	Reconfiguration in RUN	Scope with configuration software e.g. STEP 7 (TIA Portal)	
				GSD file PROFINET IO	GSD file PROFIBUS DP
	<ul style="list-style-type: none"> <li>Type C (WRe-WRe)</li> <li>Type TXK</li> </ul>				
Temperature coefficient	<ul style="list-style-type: none"> <li>Pt 0.00385055</li> <li>Pt 0.003916</li> <li>Pt 0.003902</li> <li>Pt 0.00392</li> <li>Pt 0.00385</li> <li>Ni 0.00618</li> <li>Ni 0.00672</li> <li>LG-Ni 0.005</li> </ul>	Pt 0.00385055	Yes	Channel	Channel
Temperature unit	<ul style="list-style-type: none"> <li>Degrees Celsius</li> <li>Degrees Fahrenheit</li> <li>Kelvin</li> </ul>	Degrees Celsius	Yes	Channel	Module
Reference junction <sup>5</sup>	<ul style="list-style-type: none"> <li>No reference channel mode</li> <li>Reference channel of the module</li> <li>Internal reference junction<sup>5</sup></li> <li>Reference channel of group 0 to 3</li> <li>Fixed reference temperature</li> </ul>	No reference channel mode	Yes	Channel	Channel
Smoothing	<ul style="list-style-type: none"> <li>None</li> <li>Weak</li> <li>Medium</li> <li>Strong</li> </ul>	None	Yes	Channel	Channel
Interference frequency suppression <sup>3</sup>	<ul style="list-style-type: none"> <li>60 Hz (50 ms)</li> <li>50 Hz (60 ms) <sup>1</sup></li> <li>16.6 Hz (180 ms)</li> <li>60 Hz (18.75 ms) <sup>6</sup></li> <li>50 Hz (22.5 ms) <sup>1,6</sup></li> <li>16.6 Hz (67.5 ms) <sup>6</sup></li> </ul>	50 Hz (60 ms)	Yes	Channel	Module
Scalable measuring range	<ul style="list-style-type: none"> <li>Disable</li> <li>Enable</li> </ul>	Disable	Yes	Channel	-

<sup>1</sup> Interference frequency suppression: Interfering signals at 400 Hz are automatically included in the filtering at 50 Hz.

<sup>2</sup> The settings in the "Interference frequency suppression" parameter have a direct effect on the conversion time of the channel. The analog value is therefore also affected by additionally set filtering via the "Smoothing" parameter.

<sup>3</sup> Due to the limited number of parameters of a maximum of 244 bytes per ET 200SP station with a PROFIBUS GSD configuration, the parameter assignment options are restricted. The parameter length of the I/O module is 24 bytes with PROFIBUS GSD configuration. However, if necessary you can set these parameters using data records 0 to 7 or data record 128, see appendix "Parameter data record".

<sup>4</sup> Only for configuration with PROFIBUS GSD file: The set reference junction is used with the additional parameter "Kx Reference junction activated" in the case of "Enable". In the case of "Disable", "No reference channel mode" is used for RTD and "Fixed reference temperature" is used for TC.

<sup>5</sup> Thermocouple types B and C are not suitable for reference junction temperatures below 0 °C on account of their defined characteristic curve as of 0 °C.

<sup>6</sup> By selecting this interference frequency suppression with shorter integration time, the attenuation of the interference frequency that can be achieved is reduced (see Technical Specifications).

Parameters	Value range	Default	Reconfiguration in RUN	Scope with configuration software e.g. STEP 7 (TIA Portal)	
				GSD file PROFINET IO	GSD file PROFIBUS DP
Measuring range resolution	<ul style="list-style-type: none"> <li>2 decimal places</li> <li>3 decimal places</li> </ul>	2 decimal places	Yes	Channel	-
Measuring range center	<ul style="list-style-type: none"> <li>Value within the nominal range of the measuring range</li> </ul>	0	Yes	Channel	-
Conductor resistance	<ul style="list-style-type: none"> <li>0 to 50000 mΩ</li> </ul>	0	Yes	Channel	-
Hardware interrupt high limit 1 <sup>3</sup>	<ul style="list-style-type: none"> <li>Disable</li> <li>Enable</li> </ul>	Disable	Yes	Channel	-
High limit 1 <sup>3</sup>	<ul style="list-style-type: none"> <li>Value</li> </ul>	8500	Yes	Channel	-
Hardware interrupt low limit 1 <sup>3</sup>	<ul style="list-style-type: none"> <li>Disable</li> <li>Enable</li> </ul>	Disable	Yes	Channel	-
Low limit 1 <sup>3</sup>	<ul style="list-style-type: none"> <li>Value</li> </ul>	-2000	Yes	Channel	-
Hardware interrupt high limit 2 <sup>3</sup>	<ul style="list-style-type: none"> <li>Disable</li> <li>Enable</li> </ul>	Disable	Yes	Channel	-
High limit 2 <sup>3</sup>	<ul style="list-style-type: none"> <li>Value</li> </ul>	8500	Yes	Channel	-
Hardware interrupt low limit 2 <sup>3</sup>	<ul style="list-style-type: none"> <li>Disable</li> <li>Enable</li> </ul>	Disable	Yes	Channel	-
Low limit 2 <sup>3</sup>	<ul style="list-style-type: none"> <li>Value</li> </ul>	-2000	Yes	Channel	-
Potential group	<ul style="list-style-type: none"> <li>Use potential group of the left module (dark-colored BaseUnit)</li> <li>Enable new potential group (light-colored BaseUnit)</li> </ul>	Use potential group of the left module (dark-colored BaseUnit)	No	Module	Module

- <sup>1</sup> Interference frequency suppression: Interfering signals at 400 Hz are automatically included in the filtering at 50 Hz.
- <sup>2</sup> The settings in the "Interference frequency suppression" parameter have a direct effect on the conversion time of the channel. The analog value is therefore also affected by additionally set filtering via the "Smoothing" parameter.
- <sup>3</sup> Due to the limited number of parameters of a maximum of 244 bytes per ET 200SP station with a PROFIBUS GSD configuration, the parameter assignment options are restricted. The parameter length of the I/O module is 24 bytes with PROFIBUS GSD configuration. However, if necessary you can set these parameters using data records 0 to 7 or data record 128, see appendix "Parameter data record".
- <sup>4</sup> Only for configuration with PROFIBUS GSD file: The set reference junction is used with the additional parameter "Kx Reference junction activated" in the case of "Enable". In the case of "Disable", "No reference channel mode" is used for RTD and "Fixed reference temperature" is used for TC.
- <sup>5</sup> Thermocouple types B and C are not suitable for reference junction temperatures below 0 °C on account of their defined characteristic curve as of 0 °C.
- <sup>6</sup> By selecting this interference frequency suppression with shorter integration time, the attenuation of the interference frequency that can be achieved is reduced (see Technical Specifications).

**NOTE****Unused channels**

"Deactivate" unused inputs in the parameter assignment to shorten the cycle time of the module.

A deactivated input always returns the value 7FFF<sub>H</sub>.

**NOTE**

For user calibration with a calibration device, deactivate the "Wire-break check" parameter or function.

## 5.3 Explanation of parameters

### Diagnostics: Missing supply voltage L+

Enabling of the diagnostics for missing or insufficient supply voltage L+.

### Diagnostics: Reference junction

Enabling of the reference junction diagnostics if the reference temperature of the reference junction needs to be determined for the TC channel being operated.

### Reference junction using the PROFINET GSD file

A BaseUnit with an internal temperature sensor (BU..T), the reference channel of group 0, 1, 2, 3, or channel 0 of the I/O module, if it has been configured as "Thermal resistor Pt100 climatic range Degrees Celsius", can be used as reference junction for the TC measurement.

A possible parameter assignment is represented below:

Table 5-5 RTD channel

Setting	Description
No reference channel mode	The temperature value at channel 0 can be used as a reference value for the entire module.
Reference channel of group 0, 1, 2, 3	The channel acts as a <b>transmitter</b> for the reference junction temperature of a group. The distribution is performed via the interface module. The RTD channel must be parameterized as follows: <ul style="list-style-type: none"> <li>• Measurement type/measuring range "Thermal resistance Pt100 climate range"</li> <li>• Temperature unit "Degrees Celsius"</li> </ul>

Table 5-6 TC channel

Setting	Description
Reference channel of the module	The corresponding TC channel uses channel 0 of the same module as the reference junction temperature. Channel 0 must be configured as follows, otherwise the reference junction diagnostics is triggered: <ul style="list-style-type: none"> <li>• Measurement type/measuring range "Thermal resistance Pt100 climate range"</li> <li>• Temperature unit "Degrees Celsius"</li> <li>• Reference junction "No reference channel mode"</li> </ul>
Internal reference junction	The reference junction temperature is read by an internal temperature sensor on the BaseUnit. Diagnostics: Reference junction is triggered if there is an incorrect BaseUnit type.
Reference channel of group 0, 1, 2, 3	The channel acts as a <b>receiver</b> for the reference junction temperature of a group. The RTD channel must be parameterized as <b>sender</b> as follows: <ul style="list-style-type: none"> <li>• Measurement type/measuring range "Thermal resistance Pt100 climate range"</li> <li>• Temperature unit "Degrees Celsius"</li> <li>• Reference junction: Must be the same reference channel of the group</li> </ul>
Fixed reference temperature	The reference temperature of the thermocouple is set to 0 °C. As a result, no temperature compensation is performed.

**NOTE****Shared Device and "Reference channel of group 0, 1, 2, 3"**

If the transmitter and receiver for the reference junction temperature of a group are assigned to different IO controllers, then both IO controllers must be performing data exchange with the IO device to ensure error-free operation of the temperature compensation.

## Reference junction using the PROFIBUS GSD file

A BaseUnit with an internal temperature sensor (BU..T), the reference channel of group 0, 1, 2, 3, or channel 0 of the I/O module, if it has been configured as "Thermal resistor Pt100 climatic range Degrees Celsius", can be used as reference junction for the TC measurement.

The set temperature unit (e.g. Degrees Celsius) is valid for the entire module with temperature compensation "Reference channel of the module" and "Reference channel of group 0, 1, 2, 3".

Table 5-7 RTD channel

Setting	Description
No reference channel mode	The temperature value at channel 0 can be used as a reference value for the entire module.
Reference channel of group 0, 1, 2, 3	The channel acts as a <b>transmitter</b> for the reference junction temperature of a group. The distribution is performed via the interface module. The RTD channel must be parameterized as follows: <ul style="list-style-type: none"> <li>• Measurement type/measuring range "Thermal resistance Pt100 climate range"</li> <li>• Temperature unit "Degrees Celsius"</li> </ul>

Setting	Description
Channel x Reference junction activated	<ul style="list-style-type: none"> <li>• Disable: Channel x is configured with the setting "No reference channel mode".</li> <li>• Enable: Channel x is configured with the setting selected for the "Reference junction" parameter.</li> </ul>

Table 5-8 TC channel

Setting	Description
Reference channel of the module	The corresponding TC channel uses channel 0 of the same module as the reference junction temperature. This channel must be parameterized as follows, otherwise the reference junction diagnostics is triggered: <ul style="list-style-type: none"> <li>• Measurement type/measuring range "Thermal resistance Pt100 climate range"</li> <li>• Temperature unit "Degrees Celsius"</li> <li>• Reference junction "No reference channel mode"</li> </ul>
Internal reference junction	The reference junction temperature is read by an internal temperature sensor on the BaseUnit. Diagnostics: Reference junction is triggered if there is an incorrect BaseUnit type.
Reference channel of group 0, 1, 2, 3	The channel acts as a <b>receiver</b> for the reference junction temperature of the group. The RTD channel must be parameterized as <b>sender</b> as follows: <ul style="list-style-type: none"> <li>• Measurement type/measuring range "Thermal resistance Pt100 climate range"</li> <li>• Temperature unit "Degrees Celsius"</li> <li>• Reference junction: Must be the same reference channel of the group</li> </ul>
Fixed reference temperature	The reference temperature of the thermocouple is set to 0 °C. As a result, no temperature compensation is performed.

Setting	Description
Channel x Reference junction activated	<ul style="list-style-type: none"><li>• Disable: Channel x is configured with the setting "Fixed reference temperature".</li><li>• Enable: Channel x is configured with the setting selected for the "Reference junction" parameter.</li></ul>

### Diagnostics: Overflow

Enabling of the diagnostics when the measured value exceeds the overrange.

### Diagnostics: Underflow

Enabling of the diagnostics when the measured value falls below the underrange.

### Diagnostics: Wire break

Enabling of the diagnostics if the module has no current flow or the current is insufficient for measurement at the correspondingly assigned input.

### Type/range of measurement

See the section Measurement types and measuring ranges ([Page 22](#)).

### Temperature coefficient

The temperature coefficient depends on the chemical composition of the material. In Europe, only one value is used per sensor type (default value).

The temperature coefficient ( $\alpha$  value) indicates by how much the resistance of a specific material changes relatively if the temperature increases by 1 °C.

The other values facilitate a sensor-specific setting of the temperature coefficient and enhance accuracy.

### Temperature unit

Selection between Degrees Celsius, Fahrenheit and Kelvin as the temperature unit for the selected measuring range.

## Smoothing

The individual measured values are smoothed by filtering. The smoothing can be set in 4 levels.

Smoothing time = number of module cycles (k) x cycle time of the module.

The following figure shows how many module cycles it takes for the smoothed analog value to approach 100%, depending on the configured smoothing. This applies to every signal change at the analog input.

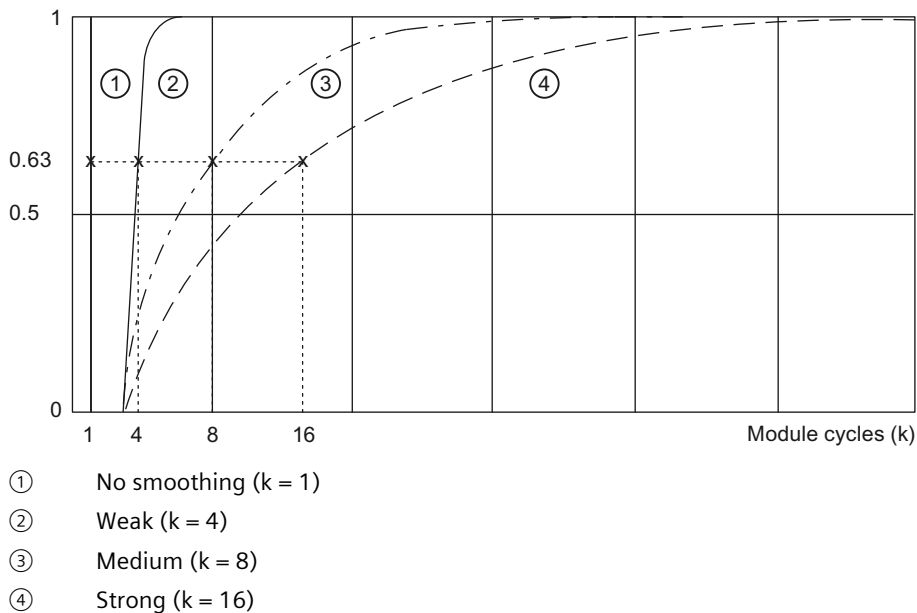

Figure 5-2 Smoothing for AI 8xRTD/TC 2-wire HF

## Interference frequency suppression

Suppresses the interferences affecting analog input modules that are caused by the frequency of the AC voltage network used.

The frequency of the AC voltage network is likely to have a negative effect on measured values particularly with measurement in the low voltage range and on thermocouples. With this parameter, the user specifies the line frequency that is predominant in the plant.

## Scalable measuring range

See the Scalable measuring range [\(Page 36\)](#) section.

## Measuring range resolution

See the Scalable measuring range [\(Page 36\)](#) section.

### Measuring range center

See the Scalable measuring range ([Page 36](#)) section.

### Conductor resistance

Parameters for the measurement types resistor and thermal resistor.

Used to compensate for the conductor resistance without having to interfere with the sensor wiring.

If the "Conductor resistor" parameter is configured higher than a value 0 mΩ, the module then automatically uses the factory calibration data.

### Hardware interrupt enable

Enabling of a hardware interrupt if the high limit 1/2 or the low limit 1/2 is violated.

### Low limit 1/2

Specify a threshold which triggers a hardware interrupt when violated.

### High limit 1/2

Specify a threshold which triggers a hardware interrupt when violated.

### Potential group

A potential group consists of a group of directly adjacent I/O modules within an ET 200SP station, which are supplied via a common supply voltage.

A potential group begins with a light-colored BaseUnit through which the required voltage is supplied for all modules of the potential group. The light-colored BaseUnit interrupts the three self-assembling voltage buses P1, P2 and AUX to the left neighbor.

Specify the slot in which a light-colored BaseUnit with supply voltage infeed or a dark-colored BaseUnit is to be located (see ET 200SP Distributed I/O System Manual (<https://support.industry.siemens.com/cs/ww/en/view/58649293>)). All additional I/O modules of this potential group are plugged into dark-colored BaseUnits. You take the potential of the self-assembling voltage buses P1, P2 and AUX from the left neighbor.

The station configuration must be completed with a server module.

### See also

You can find additional information in the system manual ET 200SP distributed I/O system (<https://support.industry.siemens.com/cs/ww/en/view/58649293>).

## 5.4 Scalable measuring range

### Function

The scalable measuring range is a limited section of a measuring range supported by the module.

It allows you to increase the resolution for a configurable section.

- The function is enabled with the "Scalable measuring range" parameter.
- The "Measuring range resolution" parameter determines the resolution to 2 or 3 decimal places for a configurable section of the measuring range.
- The "Measuring range center" parameter determines the temperature over which the scalable measuring range is symmetrically spanned.

### NOTE

The scalable measuring range is available for the temperature measuring ranges of thermal resistors (RTD) standard and thermocouples. The measuring ranges for voltage, resistor and thermal resistor climatic are not supported.

The scalable measuring range is valid for the following ranges:

- Nominal range
- Underrange
- Overrange

### Value ranges

Table 5-9 Value ranges

Scalable measuring range	Measuring range resolution		Values hex.
	2 decimal places	3 decimal places	
Overflow	> 325.11	> 32.511	7FFF <sub>H</sub>
High limit	325.11	32.511	7EFF <sub>H</sub>
Measuring range center	0	0	0 <sub>H</sub>
Low limit	-325.12	-32.512	8100 <sub>H</sub>
Underflow	<-325.12	<-32.512	8000 <sub>H</sub>

To obtain an absolute temperature, the measuring range center in the application program (as offset) must be calculated with the value of the user data of the scalable measuring range.

The measuring range center is always output in the user data as the value "0". The user data are correspondingly mapped to the bipolar input ranges in S7 format. Underflow / overflow is also formed in accordance with the limits of S7.

## Rules

- The measuring range center must be within the nominal range of the underlying measuring range. It is specified in integers.
- The scalable measuring range is spanned symmetrically over the measuring range center. Depending on the resolution, various value ranges result (①, ②).
- The scalable measuring range is limited by underflow and overflow of the underlying measuring range:
  - It is clipped at the underflow when it falls below the limit.
  - It is clipped at the overflow when it exceeds the limit (③).

## Example

The following example illustrates the effect of scalable measuring ranges:

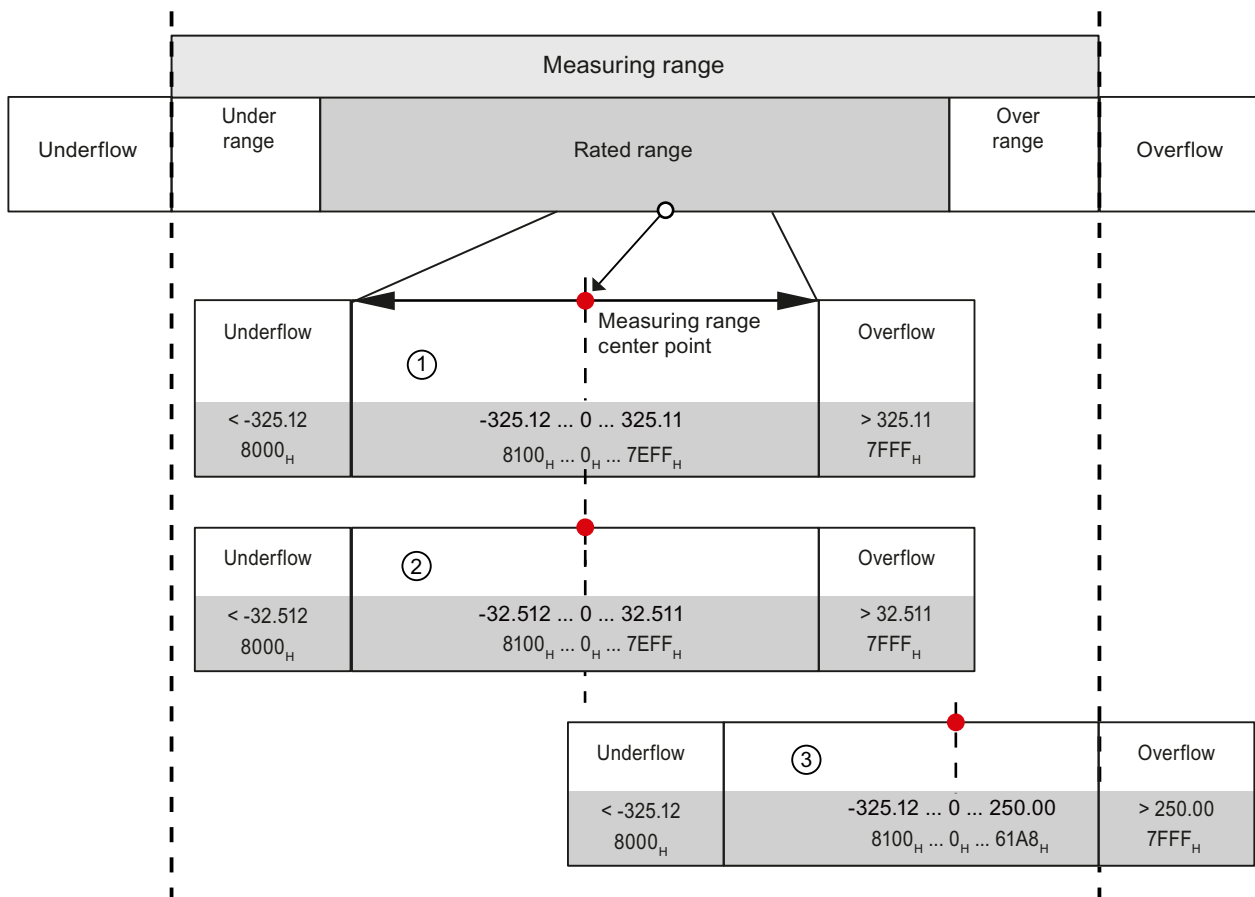

- ① Scalable measuring range with 2 decimal places in hexadecimal S7 format
- ② Scalable measuring range with 3 decimal places in hexadecimal S7 format
- ③ Scalable measuring range which is cut off at the overflow of the underlying measuring range (clipping)

Figure 5-3 Examples of scalable measuring ranges

### 5.4.1 Configuration

#### Requirement

You must select a valid temperature measuring range for configuration.

#### Configuration

The function is activated using the "Scalable measuring range" parameter. The following figure shows an example of a configuration in STEP 7:

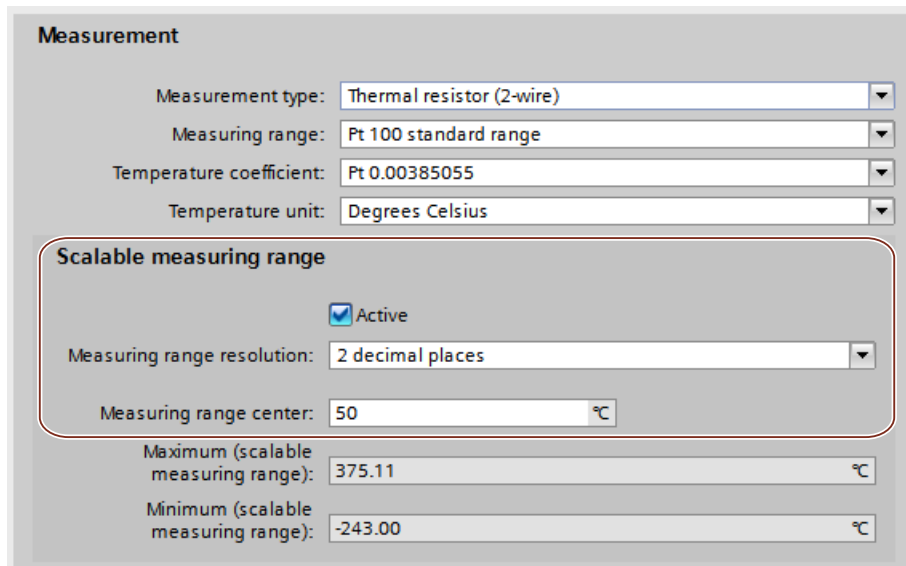

Figure 5-4 Configuration for the scalable measuring range

#### Reference

You will find more information on the configuration in the STEP 7 online help.

## 5.4.2 Evaluating data record 235

### Evaluation in the user program

In the user program, you can evaluate the status and the limits of the scalable measuring range with data record 235, which may result by reaching underflow/overflow.

### Parameter

The following table shows the structure of the parameter:

The channel parameter blocks are identical and are shown based on the example of Channel 0.

Table 5-10 Structure of data record 235

Bit →	Bit 7	Bit 6	Bit 5	Bit 4	Bit 3	Bit 2	Bit 1	Bit 0
Byte ↓								
0...1	<b>Header information</b>							
0	Reserved <sup>1</sup>		Major Version = 00 <sub>B</sub>		Minor Version = 0000 <sub>B</sub>			
1	Length of the parameter data per channel = 8 <sub>D</sub> (0000 1000 <sub>B</sub> )							
2...9	<b>Channel 0 channel parameter block</b>							
2	Reserved <sup>1</sup>					Clipping		Scalable measuring range
						0 <sub>B</sub> : No 1 <sub>B</sub> : Yes	0 <sub>B</sub> : Disabled 1 <sub>B</sub> : Enabled	
3	Reserved <sup>1</sup>				Measuring range resolution			
					010 <sub>B</sub> : 2 decimal places 011 <sub>B</sub> : 3 decimal places			
4	Measuring range center							
5								
6	Overflow							
7								
8	Underflow							
9								
10...17	<b>Channel 1 channel parameter block</b>							
18...25	<b>Channel 2 channel parameter block</b>							
26...33	<b>Channel 3 channel parameter block</b>							
34...41	<b>Channel 4 channel parameter block</b>							
42...49	<b>Channel 5 channel parameter block</b>							
50...57	<b>Channel 6 channel parameter block</b>							
58...65	<b>Channel 7 channel parameter block</b>							

<sup>1</sup> Reserved bits must be set to 0

## Description of the parameters

Table 5-11 Description of the parameters from data record 235

Parameter	Description
Scalable measuring range enabled	1 = Function is active for this channel.
Clipping	1 = Scalable measuring range cut off at the overflow / underflow of the underlying measuring range (see Examples of scalable measuring ranges).
Resolution	2 or 3 decimal places
Measuring range center	Temperature in whole °C / °F / K ("working point" for the scaling)
Overflow/underflow	Limits of the scalable measuring range

## Example

The following example shows the values for a thermal resistor Pt 100 Standard, °C:

Table 5-12 Example of a thermal resistor Pt 100 Standard

Hex. value	Dec. value	Evaluation of data record 235
00 <sub>H</sub>	0	V0.0
08 <sub>H</sub>	8	8 bytes
03 <sub>H</sub>	3	Scalable measuring range active and clipped (clipping)
02 <sub>H</sub>	2	Resolution: 2 decimal places
02EE <sub>H</sub>	750	Measuring range center: 750 °C
61A8 <sub>H</sub>	25000	Overflow (Maximum): 250.00 + 750 = 1000.00 °C Scalable measuring range is clipped at the overflow.
8100 <sub>H</sub>	-32512	Underflow (Minimum): -325.12 + 750 = 424.88 °C

## See also

[Scalable measuring range \(Page 36\)](#)

## 5.5 Address space

The module can be configured in various ways in STEP 7; see the following table. Depending on the configuration, additional/different addresses are assigned in the process image of the inputs.

### Configuration options of AI 8×RTD/TC 2-wire HF

You can configure the module with STEP 7 (TIA Portal) or with a GSD file. When you configure the module by means of the GSD file, the configurations are available under different short designations/module names; see following table. The following configurations are possible:

Table 5-13 Configuration options with GSD file

Configuration	Short designation/module name in the GSD file	Configuration software e.g., with STEP 7 (TIA Portal)	
		GSD file PROFINET IO	GSD file PROFIBUS DP
1 x 8-channel without value status	AI 8xRTD/TC 2-wire HF V2.0	X	X
1 x 8-channel with value status	AI 8xRTD/TC 2-wire HF V2.0, QI	X	X
1 x 8-channel without value status	AI 8xRTD/TC 2-wire HF V2.1	X	X
1 x 8-channel with value status	AI 8xRTD/TC 2-wire HF V2.1, QI	X	X
1 x 8-channel without value status	AI 8xRTD/TC 2-wire HF 3.0	X	X
1 x 8-channel with value status for module-internal shared input with up to 4 submodules	AI 8xRTD/TC 2-wire HF 3.0, MSI	X	-
1 x 8-channel with value status	AI 8xRTD/TC 2-wire HF 3.0, QI	X	X

### Value status (Quality Information, QI)

The value status is always enabled for the following module names:

- AI 8×RTD/TC 2-wire HF V2.0, QI
- AI 8×RTD/TC 2-wire HF V2.1, QI
- AI 8×RTD/TC 2-wire HF V3.0, QI
- AI 8×RTD/TC 2-wire HF V3.0, MSI

An additional bit is assigned to each channel for the value status. The bit for the value status indicates whether the input value read in by the user program is valid (0 = value is incorrect).

You can find more information on evaluating the value status in the ET 200SP Distributed I/O System Manual (<https://support.automation.siemens.com/WW/view/en/58649293>).

**Address space for configuration as 1 x 8-channel AI 8×RTD/TC 2-wire HF Vx.x**

The table below shows the address space allocation with configuration as a 1 x 8-channel module without value status. You can freely assign the start address for the module. The addresses of the channels are derived from the start address. "IB" stands for input byte.

The table applies to these configurations:

- AI 8×RTD/TC 2-wire HF V2.0
- AI 8×RTD/TC 2-wire HF V2.1
- AI 8×RTD/TC 2-wire HF V3.0

Table 5-14 Address space for configuration as 1 x 8-channel AI 8×RTD/TC 2-wire HF Vx.x

Bit →	Bit 7	Bit 6	Bit 5	Bit 4	Bit 3	Bit 2	Bit 1	Bit 0	Description
Byte ↓									
Assignments in the process image of the inputs (PII)									
IB x									Channel 0 (input CH0)
IB x +1									
IB x +2									Channel 1 (input CH1)
IB x +3									
IB x +4									Channel 2 (input CH2)
IB x +5									
IB x +6									Channel 3 (input CH3)
IB x +7									
IB x +8									Channel 4 (input CH4)
IB x +9									
IB x +10									Channel 5 (input CH5)
IB x +11									
IB x +12									Channel 6 (input CH6)
IB x +13									
IB x +14									Channel 7 (input CH7)
IB x +15									

**Address space for configuration as 1 x 8-channel AI 8×RTD/TC 2-wire HF Vx.x, QI**

The table below shows the address space allocation with configuration as a 1 x 8-channel module with value status. You can freely assign the start address for the module. The addresses of the channels are derived from the start address. "IB" stands for input byte.

The table is valid for these configurations:

- AI 8×RTD/TC 2-wire HF V2.0, QI
- AI 8×RTD/TC 2-wire HF V2.1, QI
- AI 8×RTD/TC 2-wire HF V3.0, QI

Table 5-15 Address space for configuration as 1 x 8-channel AI 8xRTD/TC 2-wire HF Vx.x, QI

Bit → Byte ↓	Bit 7	Bit 6	Bit 5	Bit 4	Bit 3	Bit 2	Bit 1	Bit 0	Description
Assignments in the process image of the inputs (PII)									
IB x									Channel 0 (input CH0)
IB x +1									
IB x +2									Channel 1 (input CH1)
IB x +3									
IB x +4									Channel 2 (input CH2)
IB x +5									
IB x +6									Channel 3 (input CH3)
IB x +7									
IB x +8									Channel 4 (input CH4)
IB x +9									
IB x +10									Channel 5 (input CH5)
IB x +11									
IB x +12									Channel 6 (input CH6)
IB x +13									
IB x +14									Channel 7 (input CH7)
IB x +15									
IB x +8	QI7	QI6	QI5	QI4	QI3	QI2	QI1	QI0	Value status (QI) for inputs at channels 0 to 7 (QI0 to QI7)

### Address space for configuration as 1 x 8-channel AI 8xRTD/TC 2-wire HF V3.0, MSI

The table below shows the address space allocation with configuration as a 1 x 8-channel module with value status for the module-internal shared input with up to 4 submodules. Channels 0 to 7 of the module are copied into up to 4 submodules. Channels 0 to 7 are then available with identical input values in different submodules. These submodules can be assigned to up to 4 IO controllers when the module is used in a shared device. Each IO controller has read access to the same channels.

#### Value status (Quality Information, QI)

The meaning of the value status depends on the submodule on which it occurs.

For the 1st submodule (= basic submodule), value status 0 indicates: The module detects that an error is pending at the channel and that the value is faulty.

For the 2nd, 3rd, 4th submodule (= MSI submodule), value status 0 indicates:

- The value is faulty.
- The basic submodule is not yet assigned parameters (not ready).
- The connection between the IO controller and the basic submodule has been interrupted.
- The IO controller of the basic submodule is in STOP or POWER OFF state.

## 5.5 Address space

The following table shows the address space allocation with submodules 1 and 4 and the value status. The addresses of the channels are derived from the start address. "IB" stands for input byte.

Table 5-16 Address space for configuration as 1 x 8-channel AI 8xRTD/TC 2-wire HF V3.0, MSI

Bit → Byte ↓	Bit 7	Bit 6	Bit 5	Bit 4	Bit 3	Bit 2	Bit 1	Bit 0	Description
Assignments in the process image of the inputs (PII) 1. Submodule (basic submodule)									
IB a									Channel 0 (input CH0)
IB a +1									
IB a +2									Channel 1 (input CH1)
IB a +3									
IB a +4									Channel 2 (input CH2)
IB a +5									
IB a +6									Channel 3 (input CH3)
IB a +7									
IB a +8									Channel 4 (input CH4)
IB a +9									
IB a +10									Channel 5 (input CH5)
IB a +11									
IB a +12									Channel 6 (input CH6)
IB a +13									
IB a +14									Channel 7 (input CH7)
IB a +15									
IB a +8	Q17	Q16	Q15	Q14	Q13	Q12	Q11	Q10	Value status (QI) for inputs at channels 0 to 7 (Q10 to Q17)
Assignments in the process image of the inputs (PII) 2. Submodule (MSI submodule)									
IB b									Channel 0 (input CH0)
IB b +1									
IB b +2									Channel 1 (input CH1)
IB b +3									
IB b +4									Channel 2 (input CH2)
IB b +5									
IB b +6									Channel 3 (input CH3)
IB b +7									
IB b +8									Channel 4 (input CH4)
IB b +9									
IB b +10									Channel 5 (input CH5)
IB b +11									
IB b +12									Channel 6 (input CH6)
IB b +13									

Bit → Byte ↓	Bit 7	Bit 6	Bit 5	Bit 4	Bit 3	Bit 2	Bit 1	Bit 0	Description
IB b +14									Channel 7 (input CH7)
IB b +15									
IB b +16	Q17	Q16	Q15	Q14	Q13	Q12	Q11	Q10	Value status (QI) for inputs at channels 0 to 7 (Q10 to Q17)
Assignments in the process image of the inputs (PII) 3. Submodule (MSI submodule)									
IB c									Channel 0 (input CH0)
IB c +1									
IB c +2									Channel 0 (input CH0)
IB c +3									
IB c +4									Channel 2 (input CH2)
IB c +5									
IB c +6									Channel 3 (input CH3)
IB c +7									
IB c +8									Channel 4 (input CH4)
IB c +9									
IB c +10									Channel 5 (input CH5)
IB c +11									
IB c +12									Channel 6 (input CH6)
IB c +13									
IB c +14									Channel 7 (input CH7)
IB c +15									
IB c +16	Q17	Q16	Q15	Q14	Q13	Q12	Q11	Q10	Value status (QI) for inputs at channels 0 to 7 (Q10 to Q17)
Assignments in the process image of the inputs (PII) 4. Submodule (MSI submodule)									
IB d									Channel 0 (input CH0)
IB d +1									
IB d +2									Channel 0 (input CH0)
IB d +3									
IB d +4									Channel 2 (input CH2)
IB d +5									
IB d +6									Channel 3 (input CH3)
IB d +7									
IB d +8									Channel 4 (input CH4)
IB d +9									
IB d +10									Channel 5 (input CH5)
IB d +11									
IB d +12									Channel 6 (input CH6)
IB d +13									

## 5.5 Address space

Bit →	Bit 7	Bit 6	Bit 5	Bit 4	Bit 3	Bit 2	Bit 1	Bit 0	Description
Byte ↓									
IB d +14									Channel 7 (input CH7)
IB d +15									
IB d +16	Q17	Q16	Q15	Q14	Q13	Q12	Q11	Q10	Value status (QI) for inputs at channels 0 to 7 (Q10 to Q17)

## Reference

You can find information on the **Module-internal Shared Input (MSI)** functionality in the STEP 7 online help or in the SIMATIC PROFINET with STEP 7 (<https://support.industry.siemens.com/cs/ww/en/view/49948856>) Function Manual.

## Interrupts/diagnostics alarms

### 6.1 Status and error displays

#### LED displays

The figure below shows the LED displays (status and error displays) of the module.

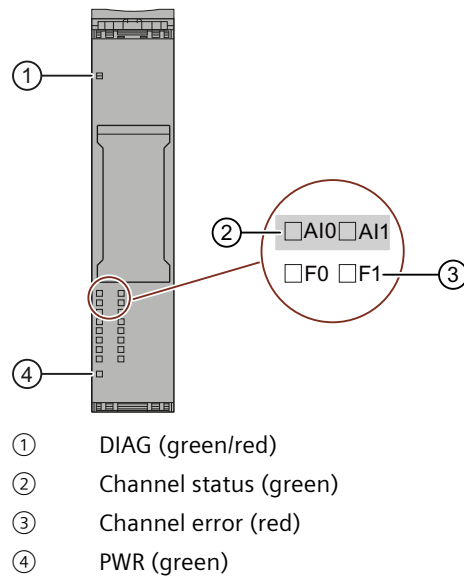

Figure 6-1 LED display

#### Meaning of the LED displays

The following tables explain the meaning of the status and error messages. Remedies for diagnostics alarms can be found in section Diagnostics alarms [\(Page 51\)](#).

### LED DIAG

Table 6-1 Error display of the DIAG LED

LED DIAG	Meaning
□ Off	Backplane bus supply of the system is interrupted or switched off
⚡ Flashes	Module parameters not assigned
■ On	Module parameters assigned and no module/channel diagnostics data available
⚡ Flashes	Module parameters assigned and module/channel diagnostics available

### Channel status/channel error LED

Table 6-2 Status and error display of the LED channel status / channel error

LEDs		Meaning
Channel status	Channel error	
□ Off	□ Off	Channel deactivated or no load voltage L+
■ On	□ Off	Channel activated and no channel diagnostics data available
□ Off	■ On	Channel activated and channel diagnostics available
■ On	■ On	Not permitted (error)

### PWR LED

Table 6-3 Status display of the PWR LED

PWR LED	Meaning
□ Off	Supply voltage L+ missing
■ On	Supply voltage L+ present

## 6.2 Interrupts

### Introduction

The IO device generates interrupts as a reaction to specific error events. Interrupts are evaluated based on the IO controller used.

### Evaluating interrupts with IO controllers

The module supports the following interrupts

- Diagnostics interrupts
- Hardware interrupts
- Maintenance events

In the event of an interrupt, interrupt OBs are automatically called in the CPU of the IO controller.

Information on the cause and type of the error is already available, based on the OB number and start information.

Detailed information on the error event can be obtained in the error OB using the instruction "RALRM" (read additional interrupt information).

### 6.2.1 Triggering of a diagnostics interrupt

#### Triggering of a diagnostics interrupt

For an incoming or outgoing event (e.g. wire break on a channel of an I/O module), the module triggers a diagnostics interrupt if this is configured accordingly.

The CPU interrupts processing of the user program and processes the diagnostics block OB 82. The event which led to the interrupt is entered in the start information of the OB 82.

## 6.2.2 Triggering a hardware interrupt

### Triggering a hardware interrupt

In the event of a hardware interrupt, the CPU interrupts processing of the user program and processes the hardware interrupt OB, e.g. OB 40. The event that triggered the interrupt is entered in the start information of the hardware interrupt OB.

For detailed information on the error event, refer to the hardware interrupt organization block with the "RALRM" instruction (read additional interrupt info) and to the STEP 7 online help.

---

#### NOTE

##### Diagnostics "Hardware interrupt lost" (from I/O module)

Do not use hardware interrupts for functional purposes (e.g. cyclic generation of hardware interrupts).

If the hardware interrupt load is too high, hardware interrupts can get lost depending on the number of I/O modules and the communication load.

---

## 6.2.3 Triggering of a maintenance event

### Triggering of a maintenance event

For the module, maintenance events signal to the user when a plant component needs to be checked or replaced.

The CPU interrupts the processing of the user program and processes the diagnostic error interrupt OB (OB 82). The event that triggered the maintenance event is entered in the start information of the diagnostic error interrupt OB.

## 6.3 Alarms

### Introduction

The module generates the following alarms:

- Diagnostics alarms
- Hardware interrupts
- Maintenance alarms

### 6.3.1 Diagnostics alarms

A diagnostics alarm is generated and the DIAG LED flashes red on the module for each diagnostics event. You can read out the diagnostics alarms, for example, in the diagnostics buffer of the CPU. You can evaluate the error codes with the user program.

Table 6-4 Diagnostics alarms, their meaning and remedies

Diagnostics alarms	Error code	Meaning	Solution
Wire break	6 <sub>H</sub>	Resistance of sensor circuit too high	Use a different sensor type or modify the wiring, for example, using cables with larger cross-section
		Wire break between the module and sensor	Connect the cable
		Channel not connected (open)	<ul style="list-style-type: none"> <li>Deactivate diagnostics</li> <li>Connect or deactivate the channel</li> </ul>
Violation of high limit <sup>1</sup>	7 <sub>H</sub>	Value lies above the overrange.	Correct module/sensor interplay
		Wire break <sup>2</sup>	See Wire break
Violation of low limit <sup>1</sup>	8 <sub>H</sub>	Value lies below the underrange.	Correct module/sensor interplay
Error	9 <sub>H</sub>	Internal module error has occurred (diagnostics alarm on channel 0 applies to the entire module).	Replace module
Parameter assignment error	10 <sub>H</sub>	The module cannot evaluate parameters for the channel. Incorrect parameter assignment.	<ul style="list-style-type: none"> <li>Correct the parameter assignment, e.g. configure wire break diagnostics only for the permitted measuring ranges.</li> </ul>
Supply voltage missing	11 <sub>H</sub>	Missing or insufficient supply voltage L+	<ul style="list-style-type: none"> <li>Check the supply voltage L+ at the BaseUnit</li> <li>Check BaseUnit type</li> </ul>
Reference channel error (reference junction)	15 <sub>H</sub>	Reference temperature of the reference junction for the TC channel being operated with compensation is invalid.	<ul style="list-style-type: none"> <li>Check BaseUnit type</li> <li>Select correct reference junction through parameter assignment<sup>3</sup></li> <li>Check whether the reference junction (reference channel of the group 0, 1, 2, 3) is only assigned once as the sender in the entire setup.</li> </ul>
Hardware interrupt lost	16 <sub>H</sub>	At least one hardware interrupt could not be reported because there were too many pending hardware interrupts.	Correct the program or the process
Channel temporarily unavailable	1F <sub>H</sub>	Firmware update in progress or update has been canceled. The module does not read any process values in this state.	<ul style="list-style-type: none"> <li>Wait for firmware update.</li> <li>Restart the firmware update.</li> </ul>
		The channel is currently being calibrated.	<ul style="list-style-type: none"> <li>Complete calibration.</li> </ul>

<sup>1</sup> The alarm refers to the diagnostics and depends on the configured measuring range.

<sup>2</sup> For resistor and thermal resistor measuring ranges with deactivated diagnostics for "wire break", this is reported by the "Violation of high limit" diagnostic.

<sup>3</sup> Shared Device and diagnostics "Reference temperature": If the sender and receiver of the reference junction temperature of a group are assigned to different IO controllers, you may need to download both configurations again in the case of diagnostics. First download the configuration containing the receiver.

**NOTE**

**Diagnostic messages in the measured value of analog input modules**

Each analog input module supplies the measured value 7FFF<sub>H</sub> or 8000<sub>H</sub> depending on the parameter assignment when an error is detected.

**6.3.2 Hardware interrupt messages**

**Evaluating hardware interrupts with IO controller**

The module generates a hardware interrupt at the following events:

- Violation of low limit 1
- Violation of high limit 1
- Violation of low limit 2
- Violation of high limit 2

You can obtain detailed information on the event in the hardware interrupt organization block with the "RALARM" (read additional interrupt information) instruction and in the STEP 7 online help.

The module channel that triggered the hardware interrupt is entered in the start information of the organization block. The following figure shows the assignment to the bits of double word 8 in local data.

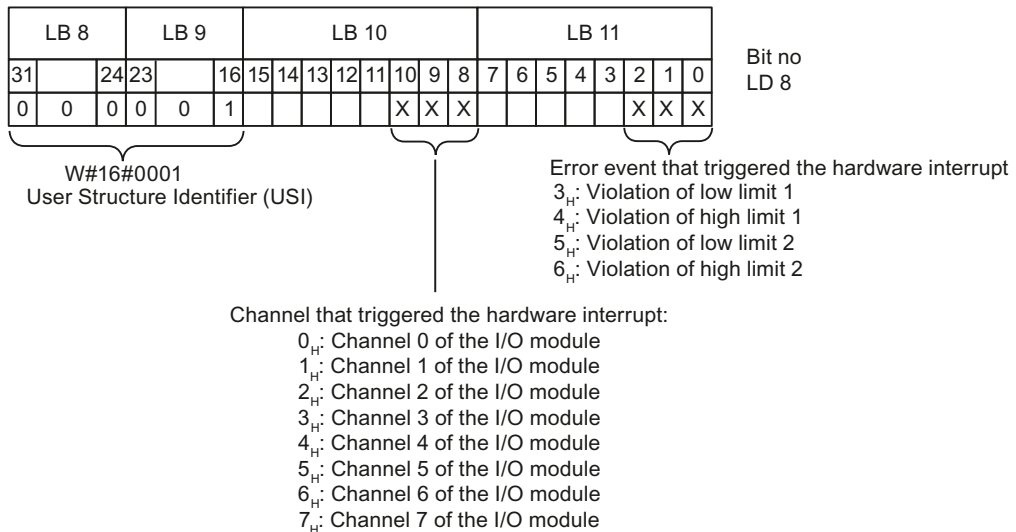

Figure 6-2 OB start information

## Structure of the additional interrupt information

Table 6-5 Structure of the additional interrupt information

Data block name	Content	Comment	Bytes
USI (User Structure Identifier)	W#16#0001	additional interrupt information for hardware interrupts of the I/O module	2
Channel that triggered the hardware interrupt.			
<b>Channel</b>	B#16#00 to B#16#07	Channel 0 to 7 of the I/O module	1
Event that triggered the hardware interrupt.			
<b>Event</b>	B#16#03	Violation of low limit 1	1
	B#16#04	Violation of high limit 1	
	B#16#05	Violation of low limit 2	
	B#16#06	Violation of high limit 2	

### 6.3.3 Maintenance alarms

For the module, maintenance events signal to the user when a plant component needs to be checked or replaced.

The CPU interrupts the processing of the user program and processes the diagnostic error interrupt OB (OB 82). The event that triggered the maintenance event is entered in the start information of the diagnostic error interrupt OB.

#### Maintenance required alarms

Every time maintenance required is detected, a maintenance event is generated. However, it has no influence on the LED DIAG on the module.

---

#### NOTE

Maintenance alarms have no direct influence on the function of the module.

---

Table 6-6 Maintenance required alarms, their meaning and possible remedies

Maintenance required alarm	Error code	Meaning / Cause	Solution
<b>Security event:</b> Firmware successfully downloaded and activated for use after a reset	0191 <sub>H</sub>	The firmware was successfully loaded into the module. This firmware update takes effect after the module is restarted.	-
<b>Security event:</b> Firmware integrity checks failed.	0192 <sub>H</sub>	The firmware was not successfully loaded into the module. This can have many different reasons, e.g. corrupted binary files or an incorrect signature.	Verify if the firmware update file you are using comes from a secure source. Download the firmware again from the Siemens support website and repeat the firmware update.

### System events in STEP 7 (TIA Portal)

The maintenance information is generated in STEP 7 (TIA Portal) with the following system events:

- Maintenance required - indicated for each port by a wrench with a green background  in the device view or in the hardware configuration.

You can find more information in the STEP 7 online help.

# Technical specifications

## Technical specifications of the AI 8xRTD/TC 2-wire HF

The following table shows the technical specifications as of 09/2019. You will find a data sheet including daily updated technical specifications on the Internet

(<https://support.industry.siemens.com/cs/ww/en/pv/6ES7134-6JF00-0CA1/td?dl=en>).

Article number	6ES7134-6JF00-0CA1
<b>General information</b>	
Product type designation	AI 8xRTD/TC 2-wire HF
HW functional status	FS22 or higher
Firmware version	V3.0.0
<ul style="list-style-type: none"> <li>FW update possible</li> </ul>	Yes
usable BaseUnits	BU type A0, A1
Color code for module-specific color-coded label	CC00
<b>Product function</b>	
<ul style="list-style-type: none"> <li>I&amp;M data</li> </ul>	Yes; I&M0 to I&M3
<ul style="list-style-type: none"> <li>Isochronous mode</li> </ul>	No
<ul style="list-style-type: none"> <li>Measuring range scalable</li> </ul>	Yes
<b>Engineering with</b>	
<ul style="list-style-type: none"> <li>STEP 7 TIA Portal configurable/integrated from version</li> </ul>	V21 HSP0495 / integrated as of V21.1
<ul style="list-style-type: none"> <li>STEP 7 configurable/integrated from version</li> </ul>	V5.7 SP3 HF3 with HSP0348 V2.0 / integrated as of V5.8
<ul style="list-style-type: none"> <li>PCS 7 configurable/integrated from version</li> </ul>	V10.1
<ul style="list-style-type: none"> <li>PROFIBUS from GSD version/GSD revision</li> </ul>	One GSD file each, Revision 3 and 5 and higher
<ul style="list-style-type: none"> <li>PROFINET from GSD version/GSD revision</li> </ul>	GSDML V2.45
<b>Operating mode</b>	
<ul style="list-style-type: none"> <li>Oversampling</li> </ul>	No
<ul style="list-style-type: none"> <li>MSI</li> </ul>	Yes
<b>CiR - Configuration in RUN</b>	
Reparameterization possible in RUN	Yes
Calibration possible in RUN	Yes
<b>Supply voltage</b>	
Rated value (DC)	24 V
permissible range, lower limit (DC)	19.2 V
permissible range, upper limit (DC)	28.8 V
Reverse polarity protection	Yes

<b>Article number</b>	<b>6ES7134-6JF00-OCA1</b>
<b>Input current</b>	
Current consumption (rated value)	34 mA
Current consumption, max.	35 mA
<b>Power loss</b>	
Power loss, typ.	0.75 W; rated voltage, 50 % active channels, 50 % of range
<b>Address area</b>	
<b>Address space per module</b>	
• Address space per module, max.	16 byte; + 1 byte for QI information
<b>Hardware configuration</b>	
Automatic encoding	Yes
• Mechanical coding element	Yes
• Type of mechanical coding element	Type A
<b>Selection of BaseUnit for connection variants</b>	
• 2-wire connection	BU type A0, A1
<b>Analog inputs</b>	
Number of analog inputs	8
• For voltage measurement	8
permissible input voltage for voltage input (destruction limit), max.	30 V
Constant measurement current for resistance-type transmitter, typ.	2 mA
Cycle time (all channels), min.	Sum of the basic conversion times and additional processing times (depending on the parameterization of the active channels)
Technical unit for temperature measurement adjustable	Yes; °C/°F/K
<b>Input ranges (rated values), voltages</b>	
• -1 V to +1 V	Yes; 16 bit incl. sign
– Input resistance (-1 V to +1 V)	1 MΩ
• -250 mV to +250 mV	Yes; 16 bit incl. sign
– Input resistance (-250 mV to +250 mV)	1 MΩ
• -50 mV to +50 mV	Yes; 16 bit incl. sign
– Input resistance (-50 mV to +50 mV)	1 MΩ
• -80 mV to +80 mV	Yes; 16 bit incl. sign
– Input resistance (-80 mV to +80 mV)	1 MΩ
<b>Input ranges (rated values), thermocouples</b>	
• Type B	Yes; 16 bit incl. sign
– Input resistance (Type B)	1 MΩ
• Type C	Yes; 16 bit incl. sign
– Input resistance (Type C)	1 MΩ

Article number	6ES7134-6JF00-0CA1
<ul style="list-style-type: none"> <li>• Type E                             <ul style="list-style-type: none"> <li>– Input resistance (Type E)</li> </ul> </li> <li>• Type J                             <ul style="list-style-type: none"> <li>– Input resistance (type J)</li> </ul> </li> <li>• Type K                             <ul style="list-style-type: none"> <li>– Input resistance (Type K)</li> </ul> </li> <li>• Type L                             <ul style="list-style-type: none"> <li>– Input resistance (Type L)</li> </ul> </li> <li>• Type N                             <ul style="list-style-type: none"> <li>– Input resistance (Type N)</li> </ul> </li> <li>• Type R                             <ul style="list-style-type: none"> <li>– Input resistance (Type R)</li> </ul> </li> <li>• Type S                             <ul style="list-style-type: none"> <li>– Input resistance (Type S)</li> </ul> </li> <li>• Type T                             <ul style="list-style-type: none"> <li>– Input resistance (Type T)</li> </ul> </li> <li>• Type U                             <ul style="list-style-type: none"> <li>– Input resistance (Type U)</li> </ul> </li> <li>• Type TXK/TXK(L) to GOST                             <ul style="list-style-type: none"> <li>– Input resistance (Type TXK/TXK(L) to GOST)</li> </ul> </li> </ul>	Yes; 16 bit incl. sign 1 MΩ Yes; 16 bit incl. sign 1 MΩ Yes; 16 bit incl. sign 1 MΩ Yes; 16 bit incl. sign 1 MΩ Yes; 16 bit incl. sign 1 MΩ Yes; 16 bit incl. sign 1 MΩ Yes; 16 bit incl. sign 1 MΩ Yes; 16 bit incl. sign 1 MΩ Yes; 16 bit incl. sign 1 MΩ Yes; 16 bit incl. sign 1 MΩ Yes; 16 bit incl. sign 1 MΩ
<b>Input ranges (rated values), resistance thermometer</b> <ul style="list-style-type: none"> <li>• Ni 100                             <ul style="list-style-type: none"> <li>– Input resistance (Ni 100)</li> </ul> </li> <li>• Ni 1000                             <ul style="list-style-type: none"> <li>– Input resistance (Ni 1000)</li> </ul> </li> <li>• LG-Ni 1000                             <ul style="list-style-type: none"> <li>– Input resistance (LG-Ni 1000)</li> </ul> </li> <li>• Ni 120                             <ul style="list-style-type: none"> <li>– Input resistance (Ni 120)</li> </ul> </li> <li>• Ni 200                             <ul style="list-style-type: none"> <li>– Input resistance (Ni 200)</li> </ul> </li> <li>• Ni 500                             <ul style="list-style-type: none"> <li>– Input resistance (Ni 500)</li> </ul> </li> <li>• Pt 100                             <ul style="list-style-type: none"> <li>– Input resistance (Pt 100)</li> </ul> </li> </ul>	Yes; 16 bit incl. sign 1 MΩ Yes; 16 bit incl. sign 1 MΩ Yes; 16 bit incl. sign 1 MΩ Yes; 16 bit incl. sign 1 MΩ Yes; 16 bit incl. sign 1 MΩ Yes; 16 bit incl. sign 1 MΩ Yes; 16 bit incl. sign 1 MΩ

Article number	6ES7134-6JF00-OCA1
<ul style="list-style-type: none"> <li>• Pt 1000                             <ul style="list-style-type: none"> <li>– Input resistance (Pt 1000)</li> </ul> </li> <li>• Pt 200                             <ul style="list-style-type: none"> <li>– Input resistance (Pt 200)</li> </ul> </li> <li>• Pt 500                             <ul style="list-style-type: none"> <li>– Input resistance (Pt 500)</li> </ul> </li> </ul>	Yes; 16 bit incl. sign 1 MΩ Yes; 16 bit incl. sign 1 MΩ Yes; 16 bit incl. sign 1 MΩ
<b>Input ranges (rated values), resistors</b> <ul style="list-style-type: none"> <li>• 0 to 150 ohms                             <ul style="list-style-type: none"> <li>– Input resistance (0 to 150 ohms)</li> </ul> </li> <li>• 0 to 300 ohms                             <ul style="list-style-type: none"> <li>– Input resistance (0 to 300 ohms)</li> </ul> </li> <li>• 0 to 600 ohms                             <ul style="list-style-type: none"> <li>– Input resistance (0 to 600 ohms)</li> </ul> </li> <li>• 0 to 3000 ohms                             <ul style="list-style-type: none"> <li>– Input resistance (0 to 3000 ohms)</li> </ul> </li> <li>• 0 to 6000 ohms                             <ul style="list-style-type: none"> <li>– Input resistance (0 to 6000 ohms)</li> </ul> </li> <li>• PTC                             <ul style="list-style-type: none"> <li>– Input resistance (PTC)</li> </ul> </li> </ul>	Yes; 15 bit 1 MΩ Yes; 15 bit 1 MΩ Yes; 15 bit 1 MΩ Yes; 15 bit 1 MΩ Yes; 15 bit 1 MΩ
<b>Thermocouple (TC)</b> <b>Temperature compensation</b> <ul style="list-style-type: none"> <li>– parameterizable</li> <li>– Reference channel of the module</li> <li>– internal comparison point</li> <li>– Reference channel of the group</li> <li>– Number of reference channel groups</li> <li>– fixed reference temperature</li> </ul>	Yes Yes Yes; with BaseUnit type A1 Yes 4; Group 0 to 3 Yes
<b>Cable length</b> <ul style="list-style-type: none"> <li>• shielded, max.</li> </ul>	200 m; 50 m with thermocouples
<b>Analog value generation for the inputs</b> Measurement principle	integrating (Sigma-Delta)
<b>Integration and conversion time/resolution per channel</b> <ul style="list-style-type: none"> <li>• Resolution with overrange (bit including sign), max.</li> <li>• Integration time, parameterizable</li> <li>• Basic conversion time, including integration time (ms)                             <ul style="list-style-type: none"> <li>– additional processing time for wire-break check</li> </ul> </li> </ul>	16 bit Yes 2 ms; In the ranges resistance thermometers, resistors and thermocouples

Article number	6ES7134-6JF00-0CA1
<ul style="list-style-type: none"> <li>Interference voltage suppression for interference frequency <math>f_1</math> in Hz</li> </ul>	16.6 / 50 / 60 Hz
<ul style="list-style-type: none"> <li>Conversion time (per channel)</li> </ul>	180 / 60 / 50 / (67.5 / 22.5 / 18.75) ms
<b>Smoothing of measured values</b>	
<ul style="list-style-type: none"> <li>Number of smoothing levels</li> </ul>	4
<ul style="list-style-type: none"> <li>parameterizable</li> </ul>	Yes
<ul style="list-style-type: none"> <li>Step: None</li> </ul>	Yes
<ul style="list-style-type: none"> <li>Step: low</li> </ul>	Yes; 4x smoothing
<ul style="list-style-type: none"> <li>Step: Medium</li> </ul>	Yes; 8x smoothing
<ul style="list-style-type: none"> <li>Step: High</li> </ul>	Yes; 16x smoothing
<b>Encoder</b>	
<b>Connection of signal encoders</b>	
<ul style="list-style-type: none"> <li>for voltage measurement</li> </ul>	Yes
<ul style="list-style-type: none"> <li>for resistance measurement with two-wire connection</li> </ul>	Yes
<ul style="list-style-type: none"> <li>for resistance measurement with three-wire connection</li> </ul>	No
<ul style="list-style-type: none"> <li>for resistance measurement with four-wire connection</li> </ul>	No
<b>Errors/accuracies</b>	
Linearity error (relative to input range), (+/-)	0.01 %; $\pm 0.1$ % for resistance thermometers and resistance
Temperature error (relative to input range), (+/-)	0.0009 %/K; $\pm 0.005$ % / K at thermocouple
Crosstalk between the inputs, min.	-50 dB
Repeat accuracy in steady state at 25 °C (relative to input range), (+/-)	0.05 %
<b>Operational error limit in overall temperature range</b>	
<ul style="list-style-type: none"> <li>Voltage, relative to input range, (+/-)</li> </ul>	0.1 %
<ul style="list-style-type: none"> <li>Resistance, relative to input range, (+/-)</li> </ul>	0.1 %
<b>Basic error limit (operational limit at 25 °C)</b>	
<ul style="list-style-type: none"> <li>Voltage, relative to input range, (+/-)</li> </ul>	0.05 %
<ul style="list-style-type: none"> <li>Resistance, relative to input range, (+/-)</li> </ul>	0.05 %
<b>Interference voltage suppression for <math>f = n \times (f_1 \pm 1 \%)</math>, <math>f_1 =</math> interference frequency</b>	
<ul style="list-style-type: none"> <li>Series mode interference (peak value of interference &lt; rated value of input range), min.</li> </ul>	70 dB; With conversion time 67.5 / 22.5 / 18.75 ms: 40 dB
<ul style="list-style-type: none"> <li>Common mode voltage, max.</li> </ul>	10 V
<ul style="list-style-type: none"> <li>Common mode interference, min.</li> </ul>	90 dB
<b>Interrupts/diagnostics/status information</b>	
Diagnostics function	Yes

<b>Article number</b>	<b>6ES7134-6JF00-OCA1</b>
<b>Alarms</b>	
<ul style="list-style-type: none"> <li>Diagnostic alarm</li> <li>Limit value alarm</li> </ul>	<p>Yes</p> <p>Yes; two upper and two lower limit values in each case</p>
<b>Diagnoses</b>	
<ul style="list-style-type: none"> <li>Monitoring the supply voltage</li> <li>Wire break</li> <li>Short-circuit</li> <li>Group error</li> <li>Overflow/Underflow</li> </ul>	<p>Yes</p> <p>Yes; channel by channel</p> <p>No</p> <p>Yes</p> <p>Yes; channel by channel</p>
<b>Diagnostics indication LED</b>	
<ul style="list-style-type: none"> <li>Monitoring of the supply voltage (PWR-LED)</li> <li>Channel status display</li> <li>for channel diagnostics</li> <li>for module diagnostics</li> </ul>	<p>Yes; green PWR LED</p> <p>Yes; green LED</p> <p>Yes; red LED</p> <p>Yes; green/red DIAG LED</p>
<b>Potential separation</b>	
<b>Potential separation channels</b>	
<ul style="list-style-type: none"> <li>between the channels</li> <li>between the channels and backplane bus</li> <li>between the channels and the power supply of the electronics</li> </ul>	<p>No</p> <p>Yes</p> <p>Yes</p>
<b>Permissible potential difference</b>	
between the inputs (UCM)	10 V DC
<b>Isolation</b>	
Isolation tested with	707 V DC (type test)
<b>Security</b>	
signed firmware update	Yes; Firmware V3.0.0 or higher
<b>Ambient conditions</b>	
<b>Ambient temperature during operation</b>	
<ul style="list-style-type: none"> <li>horizontal installation, min.</li> <li>horizontal installation, max.</li> <li>vertical installation, min.</li> <li>vertical installation, max.</li> </ul>	<p>-30 °C</p> <p>60 °C</p> <p>-30 °C</p> <p>50 °C</p>
<b>Altitude during operation relating to sea level</b>	
<ul style="list-style-type: none"> <li>Installation altitude above sea level, max.</li> </ul>	5 000 m; Restrictions for installation altitudes > 2 000 m, see manual
<b>Absolute humidity</b>	
<ul style="list-style-type: none"> <li>dew point, min.</li> </ul>	-60 °C; suitable for dry room applications

<b>Article number</b>	<b>6ES7134-6JF00-0CA1</b>
<b>Dimensions</b>	
Width	15 mm
Height	73 mm
Depth	58 mm
<b>Weights</b>	
Weight, approx.	32 g

## Operational and basic error limits for thermal resistors

Error limits for thermal resistors	
Operational limit (in the entire temperature range, in relation to input range)	
• Pt 100, Pt 200, Pt 500, Pt 1000 standard	±1.0 K
• Pt 100, Pt 200, Pt 500, Pt 1000 climatic	± 0.25 K
• Ni 100, Ni 120, Ni 200, Ni 500, Ni 1000 standard and climatic	± 0.4 K
Basic error limit (operational limit at 25 °C, in relation to input range)	
• Pt 100, Pt 200, Pt 500, Pt 1000 standard	± 0.6 K
• Pt 100, Pt 200, Pt 500, Pt 1000 climatic	± 0.13 K
• Ni 100, Ni 120, Ni 200, Ni 1000 standard and climatic	± 0.2 K

## Operational and basic error limits for thermocouples <sup>1</sup>

Error limits for thermocouples	
Operational limit for thermocouples (in the entire temperature range)	±1.5 K
Basic error limit for thermocouples (operational limit at 25 °C)	±1 K
Overall error limits when using internal compensation	
• Operational limit (in the entire temperature range at static thermal state, ambient temperature change < 0.3 K/min)	± 2.5 K
• Basic error limit (operational limit at 25 °C at static thermal state, ambient temperature change < 0.3 K/min)	±1.5 K

<sup>1</sup> The indicated error limits apply as of the following temperatures:

Thermocouple type T: -200 °C  
 Thermocouple type K: -100 °C  
 Thermocouple type B: +700 °C  
 Thermocouple type N: -150 °C  
 Thermocouple type E: -150 °C  
 Thermocouple type R: +200 °C  
 Thermocouple type S: +100 °C

## Dimension drawing

See manual ET 200SP BaseUnits

(<http://support.automation.siemens.com/WW/view/en/59753521>)

## Parameter data record

### A.1 Dependencies when configuring with GSD file

When configuring the module with a GSD file, remember that the settings of some parameters are dependent on each other.

#### Configuring with a PROFINET GSD file

The table lists the properties and their dependencies on the measurement type and measuring range for PROFINET.

Table A-1 Dependencies of the measurement type / measuring range

Measurement type	Measuring range	Temperature coefficient	Reference junction	Temperature unit	Conductor resistance
Disabled	*	*	*	*	*
Voltage	±50 mV, ±80 mV, ±250 mV, ±1 V	*	*	*	*
Resistor	150 Ω, 300 Ω, 600 Ω, 3 kΩ, 6 kΩ	*	*	*	x
Resistor	PTC	*	*	*	*
Thermal resistor	Pt100 climatic	Pt 0.00385055 Pt 0.003916 Pt 0.003902 Pt 0.00392 Pt 0.00385	Reference channel of group 0, 1, 2, 3	Degrees Celsius	x
			No reference channel mode	Degrees Celsius Degrees Fahrenheit	
	Pt200 Climatic Pt500 Climatic Pt1000 Climatic	Ni 0.00618 Ni 0.00672	No reference channel mode	Degrees Celsius Degrees Fahrenheit	

x = property is allowed, – = property is **not allowed**, \* = property is not relevant

- Use of "Reference channel of the module":
  - Channel 0 must be set as "Pt100 climatic" with temperature unit: "Degrees Celsius".
  - For each TC channel of this module that is intended to use channel 0 as reference, "Reference junction" must be set to "Reference channel of the module".
- Use of "Reference channel of group 0, 1, 2, 3":
  - An RTD channel must be set as "Pt100 climatic" with temperature unit: "Degree Celsius".
  - The "Reference junction" of this channel must be configured with "Reference channel of group 0, 1, 2, 3".
  - There must only be one RTD channel with "Reference junction" = "Reference channel of group 0, 1, 2, 3" per group 0, 1, 2, 3 and I/O device!
  - Each TC channel in the I/O device which is to use this reference must be configured with "Reference channel of group 0, 1, 2, 3" at "Reference junction".
  - If the reference channel is on channel 0, it can be used simultaneously as "Reference channel of the module".

A.1 Dependencies when configuring with GSD file

Measurement type	Measuring range	Temperature coefficient	Reference junction	Temperature unit	Conductor resistance
Thermal resistor	LG-Ni 1000 climatic	LG-Ni 0.005	No reference channel mode	Degrees Celsius Degrees Fahrenheit	x
Thermal resistor	Pt100 Standard Pt200 Standard Pt500 Standard Pt1000 Standard	Pt 0.00385055 Pt 0.003916 Pt 0.003902 Pt 0.00392 Pt 0.00385	No reference channel mode	Degrees Celsius Degrees Fahrenheit Kelvin	x
	Ni100 Standard Ni120 Standard Ni200 Standard Ni500 Standard Ni1000 Standard	Ni 0.00618 Ni 0.00672			
	LG-Ni 1000 standard	LG-Ni 0.005			
Thermocouple	Type B, N, E, R, S, J, L, T, K, U, C, TXK	*	Reference channel of the module <sup>1</sup> Internal reference junction Reference channel of group 0, 1, 2, 3 <sup>2</sup>	Degrees Celsius Degrees Fahrenheit Kelvin	*
			Fixed reference temperature		

x = property is allowed, – = property is **not allowed**, \* = property is not relevant

- 1 Use of "Reference channel of the module":
  - Channel 0 must be set as "Pt100 climatic" with temperature unit: "Degrees Celsius".
  - For each TC channel of this module that is intended to use channel 0 as reference, "Reference junction" must be set to "Reference channel of the module".
- 2 Use of "Reference channel of group 0, 1, 2, 3":
  - An RTD channel must be set as "Pt100 climatic" with temperature unit: "Degree Celsius".
  - The "Reference junction" of this channel must be configured with "Reference channel of group 0, 1, 2, 3".
  - There must only be one RTD channel with "Reference junction" = "Reference channel of group 0, 1, 2, 3" per group 0, 1, 2, 3 and I/O device!
  - Each TC channel in the I/O device which is to use this reference must be configured with "Reference channel of group 0, 1, 2, 3" at "Reference junction".
  - If the reference channel is on channel 0, it can be used simultaneously as "Reference channel of the module".

**Configuring with a PROFINET GSD file**

The table lists the properties and their dependencies on the measurement type for PROFINET.

Table A-2 Dependencies on the measurement type

Measurement type	Scalable measuring range	Measuring range resolution	Diagnostics				
			Underflow	Overflow	Wire break	Missing supply voltage L+	Reference junction
Disabled	*	*	*	*	*	*	*
Voltage	–	*	x	x	–	x	–

x = property is allowed, – = property is **not allowed**, \* = property is not relevant

- 1 Property is not relevant if "Fixed reference temperature" is used

Measurement type	Scalable measuring range	Measuring range resolution	Diagnostics				
			Underflow	Overflow	Wire break	Missing supply voltage L+	Reference junction
Resistor	–	*	x	x	x	x	–
Resistor	–	*	x	–	–	x	–
Thermal resistor	x	2 and 3 decimal places	x	x	x	x	–
Thermocouple	x	2 and 3 decimal places	x	x	x	x	x <sup>1)</sup>

x = property is allowed, – = property is **not allowed**, \* = property is not relevant

<sup>1</sup> Property is not relevant if "Fixed reference temperature" is used

### Configuring with a PROFIBUS GSD file

The table lists the properties and their dependencies on the measurement type and measuring range for PROFIBUS.

Measurement type	Measuring range	Temperature coefficient	Slot reference junction	Temperature unit	Diagnostics			
					Underflow / overflow	Wire break	Missing supply voltage L+	Reference junction
Disabled	*	*	*	*	*	*	*	*
Voltage	±50 mV ±80 mV ±250 mV ±1 V	*	*	*	x	–	x	–
Resistor	150 Ω 300 Ω 600 Ω 3 kΩ 6 kΩ	*	*	*	x	x	x	–
Resistor	PTC <sup>3</sup>	*	*	*	x	–	x	–
Thermal resistor	Pt100 climatic	Pt 0.00385055 Pt 0.003916 Pt 0.003902	Reference channel of group 0, 1, 2, 3	Degrees Celsius	x	x	x	–

x = property is allowed, – = property is **not allowed**, \* = property is not relevant

- Use of the "Reference channel of the module":
  - Channel 0 must be set to "Pt100 climatic" with the temperature unit "Degrees Celsius".
  - For each TC channel of this module that is intended to use channel 0 as reference, "Reference junction" must be set to "Enable".
- Use of "Reference channel of group 0":
  - An RTD channel must be configured as "Pt100 climatic" with temperature unit "Degree Celsius".
  - "Reference channel of group 0, 1, 2, 3" must be configured as the "Reference junction" of this channel.
  - There must only be one RTD channel with "Reference junction activated" = "Enabled" per group and line!
  - Each TC channel of this line which is to use this reference must be configured with "Enabled" for "Reference junction activated".
- Underflow = 8000<sub>H</sub>; wire break and overflow lead to 01<sub>H</sub> (triggered) → (no diagnostics), wire break and overflow are therefore not relevant.

A.1 Dependencies when configuring with GSD file

Measurement type	Measuring range	Temperature coefficient	Slot reference junction	Temperature unit	Diagnostics			
					Underflow / overflow	Wire break	Missing supply voltage L+	Reference junction
Thermal resistor	Pt100 climatic	Pt 0.00392 Pt 0.00385	No reference channel mode	Degrees Celsius Degrees Fahrenheit	x	x	x	–
	Pt200 Pt500 Pt1000 climatic	Pt 0.00385055 Pt 0.003916 Pt 0.003902 Pt 0.00392 Pt 0.00385	No reference channel mode	Degrees Celsius Degrees Fahrenheit	x	x	x	–
Thermal resistor	Pt100 Pt200 Pt500 Pt1000 standard	Pt 0.00385055 Pt 0.003916 Pt 0.003902 Pt 0.00392 Pt 0.00385	No reference channel mode	Degrees Celsius Degrees Fahrenheit Kelvin	x	x	x	–
	Ni100 Ni120 Ni200 Ni500 Ni1000 climatic	Ni 0.00618 Ni 0.00672	No reference channel mode	Degrees Celsius Degrees Fahrenheit	x	x	x	–
	Ni100 Ni120 Ni200 Ni500 Ni1000 standard	Ni 0.00618 Ni 0.00672	No reference channel mode	Degrees Celsius Degrees Fahrenheit Kelvin	x	x	x	–
Thermal resistor	LG-Ni 1000 climatic	LG-Ni 0.005	No reference channel mode	Degrees Celsius Degrees Fahrenheit	x	x	x	–

x = property is allowed, – = property is **not allowed**, \* = property is not relevant

- 1 Use of the "Reference channel of the module":
  - Channel 0 must be set to "Pt100 climatic" with the temperature unit "Degrees Celsius".
  - For each TC channel of this module that is intended to use channel 0 as reference, "Reference junction" must be set to "Enable".
- 2 Use of "Reference channel of group 0":
  - An RTD channel must be configured as "Pt100 climatic" with temperature unit "Degree Celsius".
  - "Reference channel of group 0, 1, 2, 3" must be configured as the "Reference junction" of this channel.
  - There must only be one RTD channel with "Reference junction activated" = "Enabled" per group and line!
  - Each TC channel of this line which is to use this reference must be configured with "Enabled" for "Reference junction activated".
- 3 Underflow = 8000<sub>H</sub>; wire break and overflow lead to 01<sub>H</sub> (triggered) → (no diagnostics), wire break and overflow are therefore not relevant.

## A.2 Parameter assignment and structure of parameter data record

Measurement type	Measuring range	Temperature coefficient	Slot reference junction	Temperature unit	Diagnostics			
					Underflow / overflow	Wire break	Missing supply voltage L+	Reference junction
Thermal resistor	LG-Ni 1000 standard	LG-Ni 0.005	No reference channel mode	Degrees Celsius Degrees Fahrenheit Kelvin	x	x	x	–
Thermocouple	Type B, N, E, R, S, J, L, T, K, U, C, TXK	*	Reference channel of the module <sup>1</sup> Internal reference junction Reference channel of group 0, 1, 2, 3 <sup>2</sup>	Degrees Celsius Degrees Fahrenheit Kelvin	x	x	x	x
			Fixed reference temperature	Degrees Celsius Degrees Fahrenheit Kelvin	x	x	x	*

x = property is allowed, – = property is **not allowed**, \* = property is not relevant

- 1 Use of the "Reference channel of the module":
  - Channel 0 must be set to "Pt100 climatic" with the temperature unit "Degrees Celsius".
  - For each TC channel of this module that is intended to use channel 0 as reference, "Reference junction" must be set to "Enable".
- 2 Use of "Reference channel of group 0":
  - An RTD channel must be configured as "Pt100 climatic" with temperature unit "Degree Celsius".
  - "Reference channel of group 0, 1, 2, 3" must be configured as the "Reference junction" of this channel.
  - There must only be one RTD channel with "Reference junction activated" = "Enabled" per group and line!
  - Each TC channel of this line which is to use this reference must be configured with "Enabled" for "Reference junction activated".
- 3 Underflow = 8000<sub>H</sub>; wire break and overflow lead to 01<sub>H</sub> (triggered) → (no diagnostics), wire break and overflow are therefore not relevant.

## A.2 Parameter assignment and structure of parameter data record

The data record of the module has an identical structure, regardless of whether you configure the module with PROFIBUS DP or PROFINET IO. With data record 128, you can reconfigure the module in your user program regardless of your programming. This means that you can use all the functions of the module even if you configured it via PROFIBUS-GSD.

### Parameter assignment in the user program

You can reassign the module parameters in RUN. For example, the measuring range of selected channels can be changed in RUN without having an effect on the other channels.

## Changing parameters in RUN

The "WRREC" instruction is used to transfer the parameters to the module using data record 128. The parameters set with STEP 7 will not be changed on the CPU, which means that the parameters set in STEP 7 will be valid again after a restart.

## Output parameter STATUS

If errors occur when transferring parameters with the "WRREC" instruction, the module continues operation with the previous parameter assignment. The STATUS output parameter contains a corresponding error code.

You will find a description of the "WRREC" instruction and the error codes in the STEP 7 online help.

## Structure of data record 128 (as of V2.1)

The following table shows the structure of data record 128.

Table A-3 Structure of data record 128

Bit →	Bit 7	Bit 6	Bit 5	Bit 4	Bit 3	Bit 2	Bit 1	Bit 0
Byte ↓								
0...1	<b>Header information</b>							
0	Reserved <sup>1</sup>		Major Version = 01 <sub>B</sub>		Minor Version = 0000 <sub>B</sub>			
1	Length of a channel parameter block = 22 <sub>D</sub> (0001 0110 <sub>B</sub> )							
2...23	<b>Channel 0 channel parameter block</b>							
2	<b>Measurement type</b> BYTE: See table Coding for measurement types <a href="#">(Page 71)</a>							
3	<b>Measuring range</b> BYTE: See table Coding for measuring ranges <a href="#">(Page 72)</a>							
4	<b>Temperature coefficient</b> BYTE: See table Coding for temperature coefficient for temperature measurement <a href="#">(Page 73)</a>							
5	<b>Interference frequency suppression</b>				<b>Smoothing</b>			
	0001 <sub>B</sub> : 60 Hz (50 ms) 0010 <sub>B</sub> : 50 Hz (60 ms) 0100 <sub>B</sub> : 16.6 Hz (180 ms) 1010 <sub>B</sub> : 60 Hz (18.75 ms) as of V2.1 1011 <sub>B</sub> : 50 Hz (22.5 ms) as of V2.1 1100 <sub>B</sub> : 16.7 Hz (67.5 ms) as of V2.1				0000 <sub>B</sub> : None 0001 <sub>B</sub> : Weak 0010 <sub>B</sub> : Medium 0011 <sub>B</sub> : Strong			
6	<b>Reference junction</b> • For RTD as reference channel transmitter • For TC as reference channel receiver				Reserved <sup>1</sup>		<b>Temperature unit</b>	

<sup>1</sup> Reserved bits must be set to 0

## A.2 Parameter assignment and structure of parameter data record

Bit →	Bit 7	Bit 6	Bit 5	Bit 4	Bit 3	Bit 2	Bit 1	Bit 0
Byte ↓								
6	0000 <sub>B</sub> : No reference channel mode 0010 <sub>B</sub> : Reference channel operation of the module 0011 <sub>B</sub> : Internal reference junction 1000 <sub>B</sub> : Reference channel of group 0 1001 <sub>B</sub> : Reference channel of group 1 1010 <sub>B</sub> : Reference channel of group 2 1011 <sub>B</sub> : Reference channel of group 3 1111 <sub>B</sub> : fixed reference temperature				Reserved <sup>1</sup>		00 <sub>B</sub> : Degrees Celsius 01 <sub>B</sub> : Degrees Fahrenheit 10 <sub>B</sub> : Kelvin (not for climatic measuring range)	
7	<b>Hardware interrupt low limit 1</b> 0 <sub>B</sub> : Disabled 1 <sub>B</sub> : Enabled	<b>Hardware interrupt high limit 1</b> 0 <sub>B</sub> : Disabled 1 <sub>B</sub> : Enabled	<b>Hardware interrupt low limit 2</b> 0 <sub>B</sub> : Disabled 1 <sub>B</sub> : Enabled	<b>Hardware interrupt high limit 2</b> 0 <sub>B</sub> : Disabled 1 <sub>B</sub> : Enabled	Reserved <sup>1</sup>			
8	<b>Diagnostics overflow</b> 0 <sub>B</sub> : Disabled 1 <sub>B</sub> : Enabled	<b>Diagnostics Underflow</b> 0 <sub>B</sub> : Disabled 1 <sub>B</sub> : Enabled	<b>Diagnostics Reference junction</b> 0 <sub>B</sub> : Disabled 1 <sub>B</sub> : Enabled	<b>Diagnostics: Wire break</b> 0 <sub>B</sub> : Disabled 1 <sub>B</sub> : Enabled	Reserved <sup>1</sup>			<b>Diagnostics: Missing supply voltage L+</b> 0 <sub>B</sub> : Disabled 1 <sub>B</sub> : Enabled
9	Reserved <sup>1</sup>				<b>Measuring range resolution</b> 010 <sub>B</sub> : 2 decimal places 011 <sub>B</sub> : 3 decimal places		<b>Scalable measuring range</b> 0 <sub>B</sub> : Disabled 1 <sub>B</sub> : Enabled	
10	Reserved <sup>1</sup>							
11	Reserved <sup>1</sup>							
12	<b>Hardware interrupt high limit 1:</b>							
13	WORD: For value range, see table Limits for hardware interrupts ( <a href="#">Page 73</a> )							
14	<b>Hardware interrupt low limit 1</b>							
15	WORD: For value range, see table Limits for hardware interrupts ( <a href="#">Page 73</a> )							
16	<b>Hardware interrupt high limit 2</b>							
17	WORD: For value range, see table Limits for hardware interrupts ( <a href="#">Page 73</a> )							
18	<b>Hardware interrupt low limit 2</b>							
19	WORD: For value range, see table Limits for hardware interrupts ( <a href="#">Page 73</a> )							
20	<b>Cable resistance, 0 to 50 000 mΩ</b>							
21	WORD: Value range: 0 to 50000 <sub>D</sub>							
22	<b>Measuring range center</b>							
23	(in integers, temperature unit as the channel in byte 6 is set) WORD: For value range, see table Representation of analog values ( <a href="#">Page 77</a> )							
24...45	<b>Channel 1 channel parameter block</b>							
46...67	<b>Channel 2 channel parameter block</b>							
68...89	<b>Channel 3 channel parameter block</b>							

<sup>1</sup> Reserved bits must be set to 0

A.2 Parameter assignment and structure of parameter data record

Bit →	Bit 7	Bit 6	Bit 5	Bit 4	Bit 3	Bit 2	Bit 1	Bit 0
Byte ↓								
90...111	Channel 4 channel parameter block							
112...1-34	Channel 5 channel parameter block							
134...1-55	Channel 6 channel parameter block							
156...1-77	Channel 7 channel parameter block							

<sup>1</sup> Reserved bits must be set to 0

**Structure of data records 0 to 7**

The following tables show the structure of the data records 0 to 7. The header information and the channel parameter blocks are identical to data record 128. With data records 0 to 7, the header information and the channel parameter block of a channel are written.

Table A-4 Structure of data record 0

Bit →	Bit 7	Bit 6	Bit 5	Bit 4	Bit 3	Bit 2	Bit 1	Bit 0
Byte ↓								
0...1	Header information							
2...23	Channel 0 channel parameter block							

Table A-5 Structure of data record 1

Bit →	Bit 7	Bit 6	Bit 5	Bit 4	Bit 3	Bit 2	Bit 1	Bit 0
Byte ↓								
0...1	Header information							
2...23	Channel 1 channel parameter block							

Table A-6 Structure of data record 2

Bit →	Bit 7	Bit 6	Bit 5	Bit 4	Bit 3	Bit 2	Bit 1	Bit 0
Byte ↓								
0...1	Header information							
2...23	Channel 2 channel parameter block							

Table A-7 Structure of data record 3

Bit →	Bit 7	Bit 6	Bit 5	Bit 4	Bit 3	Bit 2	Bit 1	Bit 0
Byte ↓								
0...1	Header information							
2...23	Channel 3 channel parameter block							

Table A-8 Structure of data record 4

Bit →	Bit 7	Bit 6	Bit 5	Bit 4	Bit 3	Bit 2	Bit 1	Bit 0
Byte ↓								
0...1	Header information							
2...23	Channel 4 channel parameter block							

Table A-9 Structure of data record 5

Bit →	Bit 7	Bit 6	Bit 5	Bit 4	Bit 3	Bit 2	Bit 1	Bit 0
Byte ↓								
0...1	Header information							
2...23	Channel 5 channel parameter block							

Table A-10 Structure of data record 6

Bit →	Bit 7	Bit 6	Bit 5	Bit 4	Bit 3	Bit 2	Bit 1	Bit 0
Byte ↓								
0...1	Header information							
2...23	Channel 6 channel parameter block							

Table A-11 Structure of data record 7

Bit →	Bit 7	Bit 6	Bit 5	Bit 4	Bit 3	Bit 2	Bit 1	Bit 0
Byte ↓								
0...1	Header information							
2...23	Channel 7 channel parameter block							

## A.3 Coding for measurement types

### Coding for measurement types

The following table contains the coding for the measurement types of the analog input module.

Table A-12 Coding for measurement types

Measurement type	Coding
Disabled	0000 0000
Voltage	0000 0001
Resistor, 2-wire connection	0000 0110
Thermal resistor, 2-wire connection	0000 1001
Thermocouple	0000 1010

## A.4 Coding for measuring ranges

### Coding for measuring ranges

The following table contains the coding for the measuring ranges of the analog input module.

Table A-13 Coding for measuring ranges

Measuring range	Coding
Voltage	
50 mV	0000 0001
80 mV	0000 0010
250 mV	0000 0011
1 V	0000 0101
Resistance	
150 $\Omega$	0000 0001
300 $\Omega$	0000 0010
600 $\Omega$	0000 0011
3 k $\Omega$	0000 0100
6 k $\Omega$	0000 0101
PTC	0000 1111
Thermal resistor climatic	
Pt 100	0000 0000
Pt 200	0000 0111
Pt 500	0000 1000
Pt 1000	0000 1001
Thermal resistor standard	
Pt 100	0000 0010
Pt 200	0000 1011
Pt 500	0000 0100
Pt 1000	0000 0101
Thermal resistor climatic	
Ni 100	0000 0001
Ni 120	0000 1101
Ni 200	0001 0001
Ni 500	0001 0011
Ni 1000	0000 1010
Thermal resistor standard	
Ni 100	0000 0011
Ni 120	0000 1100
Ni 200	0001 0000
Ni 500	0001 0010
Ni 1000	0000 0110
Thermal resistor	
LG Ni 1000 climatic	0001 1101
LG Ni 1000 standard	0001 1100
Thermocouple	
Type B	0000 0000
Type N	0000 0001
Type E	0000 0010
Type R	0000 0011
Type S	0000 0100
Type J	0000 0101

Measuring range	Coding
Type L	0000 0110
Type T	0000 0111
Type K	0000 1000
Type U	0000 1001
Type C	0000 1010
Type TXK	0000 1011

## A.5 Coding for temperature coefficient for temperature measurement

### Coding for temperature coefficient for temperature measurement

The following table contains the coding for the temperature coefficients of the analog input module.

Table A-14 Coding for temperature coefficient for temperature measurement

Temperature coefficient	Coding
Pt 0.00385055	0000 0000
Pt 0.003916	0000 0001
Pt 0.003902	0000 0010
Pt 0.00392	0000 0011
Pt 0.00385	0000 0100
Ni 0.00618	0000 1000
Ni 0.00672	0000 1001
LG-Ni 0.005	0000 1010

## A.6 Limits for hardware interrupts

### Limits for hardware interrupts

The following tables show the permissible limits of the hardware interrupts for the measurement type.

- The value in use is specified.
- The limits depend on the measurement type and the measuring range.
- The value for the overflow must be larger than the value for the underflow.
- The limits are specified as decimal values.

A.6 Limits for hardware interrupts

The conversion to the respective temperature unit is (1 digit = 0.1) for the standard range and (1 digit = 0.01) for the climate range, see section Representation of analog values (Page 77).

Table A-15 Limits for resistor and voltage

Resistor (all possible measuring range settings)	Voltage	
32510	32510	Overflow
1	-32511	Underflow

Table A-16 Limits for thermocouple types B, C, and E

Thermocouple									
Type B			Type C			Type E			
°C	°F	K	°C	°F	K	°C	°F	K	
20699	32765	23431	24999	32765	27731	11999	21919	14731	Overflow
-1199	-1839	1533	-1199	-1839	1533	-2699	-4539	33	Underflow

Table A-17 Limits for thermocouple types R, S, J, and L

Thermocouple									
Types R, S			Type J			Type L			
°C	°F	K	°C	°F	K	°C	°F	K	
20189	32765	22921	14499	26419	17231	11499	21019	14231	Overflow
-1699	-2739	1033	-2099	-3459	633	-1999	-3279	733	Underflow

Table A-18 Limits for thermocouple types T, K, and U

Thermocouple									
Type T			Type K			Type U			
°C	°F	K	°C	°F	K	°C	°F	K	
5399	10039	8131	16219	29515	18951	8499	15619	11231	Overflow
-2699	-4539	33	-2699	-4539	33	-1999	-3279	733	Underflow

Table A-19 Limits for thermocouple types N and TXK

Thermocouple						
Type N			Type TXK			
°C	°F	K	°C	°F	K	
15499	28219	18231	10499	19219	13231	Overflow
-2699	-4539	33	-1999	-3279	733	Underflow

Table A-20 Limits for thermal resistor

Thermal resistor					
Standard			Climatic		
°C	°F	K	°C	°F	

Thermal resistor						
Pt	9999	18319	12731	15499	31099	Overflow
	-2429	-4053	303	-14499	-22899	Underflow
Ni, Ni-LG	2949	5629	5681	29499	32765	Overflow
	-1049	-1569	1683	-10499	-15699	Underflow

## A.7 Errors when transferring the data record

### Error transferring the data record

The module always checks all values of the data record to be sent. The module applies the values from the data record only when all values have been transmitted without errors.

The WRREC instruction for writing data records returns corresponding error codes when errors occur in the STATUS parameter, see also the description of the "STATUS" parameter in the STEP 7 online help).

The following table shows the module-specific error codes and their meaning for parameter data record 128.

Error code in STATUS parameter (hexadecimal)				Meaning	Solution
Byte 0	Byte 1	Byte 2	Byte 3		
DF	80	B0	xx	Number of the data record unknown.	Enter a valid number for the data record.
DF	80	B1	xx	Length of the data record incorrect.	Enter a valid value for the data record length.
DF	80	B2	xx	Module cannot be reached.	<ul style="list-style-type: none"> <li>• Check station</li> <li>• Plug the module in correctly.</li> <li>• Check the parameters of the WRREC block.</li> </ul>
DF	80	I0	xx	Wrong version or error in the header information.	Correct the version, length and number of parameter blocks.
DF	80	I1	xx	Parameter error	Check the parameters of the module.

## A.8 Switchable wire break check

### Function

The "Switchable wire break check" is available for thermocouples. It switches off the wire break check for the module.

This is required, for example, to calibrate thermocouples, since the test current necessary for a wire break check leads to measurement errors during calibration.

A.8 Switchable wire break check

The function has no effect on channels that are not assigned in the thermocouple mode.

**NOTE**

**Startup and parameter reassignment**

The wire break check is switched on again at each startup and during any parameter reassignment of the module.

**Switch-off via the user program**

You can deactivate the wire break check using data record 237.

Table A-21 Structure of data record 237, switchable wire break check

Byte	Function	Format	Value	Description
0	Command	UBYTE	80 <sub>H</sub>	Wire break check
1	Identifier	UBYTE	00 <sub>H</sub>	Not relevant
2	Channel number	UBYTE	FF <sub>H</sub>	All channels
3	Calibration step	UBYTE	FF <sub>H</sub>	First triggering
4	Measurement type	UBYTE	00 <sub>H</sub>	Not relevant
5	Measuring range	UBYTE	00 <sub>H</sub>	Not relevant
6	Action	UBYTE	01 <sub>H</sub>	Deactivate wire break check
			02 <sub>H</sub>	Activate wire break check
7...17	Reserved	UBYTE	00 <sub>H</sub>	Not relevant

## Representation of analog values

This appendix shows the analog values for all measuring ranges supported by the analog input module AI 8xRTD/TC 2-wire HF.

### Measured value resolution

The resolution of the analog values differs depending on the analog module and its parameter assignment.

Each analog value is written left aligned to the tags. The bits marked with "x" are set to "0".

---

#### NOTE

##### Temperature values

The digitized temperature values are the result of a conversion in the analog module. The following resolution therefore does not apply to temperature values.

---

Table B-1 Resolution of the analog values

Resolution in bits including sign	Values		Analog value	
	Decimal	Hexadecimal	High byte	Low byte
14	4	4 <sub>H</sub>	Sign 0 0 0 0 0 0 0	0 0 0 0 0 1 x x
15	2	2 <sub>H</sub>	Sign 0 0 0 0 0 0 0	0 0 0 0 0 0 1 x
16	1	1 <sub>H</sub>	Sign 0 0 0 0 0 0 0	0 0 0 0 0 0 0 1

## B.1 Measured values for wire break and reference channel mode

### Measured values for wire break

Table B-2 Measured values for a wire break as a function of enabled diagnostic information in RTD and TC operating modes

Programmable diagnostics		Measured value		Explanation
Wire break	Underflow			
Enable	*	32767	7FFF <sub>H</sub>	The "wire break" diagnostics is reported.
Disable	*	32767	7FFF <sub>H</sub>	No diagnostics reported. A wire-break check is carried out (i.e. test current flows).
Disable <sup>1</sup>	*	Undefined		No "wire break" diagnostics is reported. No wire-break check is carried out (i.e. no test current flows). This is required to calibrate thermocouples, since the measuring current necessary for a wire-break check leads to measurement errors during calibration.

\* Parameter assignment not relevant

<sup>1</sup> The wire-break check can only be disabled via data set 237.

Table B-3 Measured values in case of a line break in a TC measurement with enabled reference junction (reference channel) depending on enabled diagnostic information

Case	Programmable diagnostics				Measured value			
	Reference channel		TC channel		Reference channel		TC channel	
	Wire break	Underflow	Wire break	Underflow				
1	Enable <sup>3</sup>	* <sup>3</sup>	*	* <sup>2</sup>	32767 <sup>3</sup>	7FFF <sub>H</sub> <sup>3</sup>	32767 <sup>4</sup>	7FFF <sub>H</sub> <sup>4</sup>
2	Disable <sup>3</sup>	* <sup>3</sup>	*	* <sup>2</sup>	32767 <sup>3</sup>	7FFF <sub>H</sub> <sup>3</sup>	32767 <sup>4</sup>	7FFF <sub>H</sub> <sup>4</sup>
3	*	*	Enable <sup>3</sup>	* <sup>3</sup>	Valid	Valid	32767 <sup>3</sup>	7FFF <sub>H</sub> <sup>3</sup>
4	*	*	Disable <sup>3</sup>	* <sup>3</sup>	Valid	Valid	32767 <sup>3</sup>	7FFF <sub>H</sub> <sup>3</sup>
5	*	*	Disable <sup>1,3</sup>	* <sup>3</sup>	Valid	Valid	Undefined	

\* Parameter assignment not relevant

<sup>1</sup> The wire-break check can only be disabled via data set 237.

<sup>2</sup> Diagnostics is suppressed in the event of a reference channel error.

<sup>3</sup> Channel with line break

<sup>4</sup> Measured value taken from the reference channel

Explanations of the cases:

Case	Reference channel	TC channel
1	The "wire break" diagnostics is reported. This has a higher priority than the "Underflow" diagnostics.*	The "Reference channel error" diagnostics is reported if this is enabled. Where own pending diagnostic information ("overflow" or "underflow") is reported as outgoing. Wire break diagnostics is detected independently of the measured value and has the same priority as the

Case	Reference channel	TC channel
		"Reference channel error" diagnostics. Both items of diagnostic information can be pending simultaneously. The measured value of the reference channel (RTD channel) is adopted for the TC channel. The validity of the measured value of the TC channel is irrelevant.
2	No diagnostics reported. A wire-break check is carried out (i.e. test current flows).*	Behavior corresponds to case 1.
3	Measured values are in the valid measuring range	The "wire break" diagnostics is reported.*
4	Measured values are in the valid measuring range	No diagnostics reported. A wire-break check is carried out (i.e. test current flows).*
5	Measured values are in the valid measuring range	No "wire break" diagnostics is reported. No wire-break check is carried out (i.e. no test current flows). This is required to calibrate thermocouples, since the measuring current necessary for a wire-break check leads to measurement errors during calibration.*

\* Channel with wire break

## B.2 Representation of input ranges

In the following tables, you can find the digitized representation of the bipolar and unipolar input ranges. The resolution is 16 bits.

Table B-4 Bipolar input ranges

Dec. value	Measured value in %	Data word																Range
		2 <sup>15</sup>	2 <sup>14</sup>	2 <sup>13</sup>	2 <sup>12</sup>	2 <sup>11</sup>	2 <sup>10</sup>	2 <sup>9</sup>	2 <sup>8</sup>	2 <sup>7</sup>	2 <sup>6</sup>	2 <sup>5</sup>	2 <sup>4</sup>	2 <sup>3</sup>	2 <sup>2</sup>	2 <sup>1</sup>	2 <sup>0</sup>	
32767	>117.589	0	1	1	1	1	1	1	1	1	1	1	1	1	1	1	1	Overflow
32511	117.589	0	1	1	1	1	1	1	0	1	1	1	1	1	1	1	Overrange	
27649	100.004	0	1	1	0	1	1	0	0	0	0	0	0	0	0	1		
27648	100.000	0	1	1	0	1	1	0	0	0	0	0	0	0	0	0	Nominal range	
1	0.003617	0	0	0	0	0	0	0	0	0	0	0	0	0	0	1		
0	0.000	0	0	0	0	0	0	0	0	0	0	0	0	0	0	0		
-1	-0.003617	1	1	1	1	1	1	1	1	1	1	1	1	1	1	1		
-27648	-100.000	1	0	0	1	0	1	0	0	0	0	0	0	0	0	0		
-27649	-100.004	1	0	0	1	0	0	1	1	1	1	1	1	1	1	1	Underrange	
-32512	-117.593	1	0	0	0	0	0	0	1	0	0	0	0	0	0	0		
-32768	<-117.593	1	0	0	0	0	0	0	0	0	0	0	0	0	0	0	Underflow	

## B.3 Representation of analog values in voltage measuring ranges

Table B-5 Unipolar input ranges

Dec. value	Measured value in %	Data word															Range	
		2 <sup>15</sup>	2 <sup>14</sup>	2 <sup>13</sup>	2 <sup>12</sup>	2 <sup>11</sup>	2 <sup>10</sup>	2 <sup>9</sup>	2 <sup>8</sup>	2 <sup>7</sup>	2 <sup>6</sup>	2 <sup>5</sup>	2 <sup>4</sup>	2 <sup>3</sup>	2 <sup>2</sup>	2 <sup>1</sup>		2 <sup>0</sup>
32767	>117.589	0	1	1	1	1	1	1	1	1	1	1	1	1	1	1	1	Overflow
32511	117.589	0	1	1	1	1	1	1	0	1	1	1	1	1	1	1	1	Overrange
27649	100.004	0	1	1	0	1	1	0	0	0	0	0	0	0	0	0	1	
27648	100.000	0	1	1	0	1	1	0	0	0	0	0	0	0	0	0	0	Nominal range
1	0.003617	0	0	0	0	0	0	0	0	0	0	0	0	0	0	0	1	
0	0.000	0	0	0	0	0	0	0	0	0	0	0	0	0	0	0	0	
-1	-0.003617	1	1	1	1	1	1	1	1	1	1	1	1	1	1	1	1	Underrange
-4864	-17.593	1	1	1	0	1	1	0	1	0	0	0	0	0	0	0	0	
-32768	<-17.593	1	0	0	0	0	0	0	0	0	0	0	0	0	0	0	0	Underflow

### B.3 Representation of analog values in voltage measuring ranges

The following tables list the decimal and hexadecimal values (codes) of the possible voltage measuring ranges.

Table B-6 Voltage measuring range  $\pm 1$  V

Values		Voltage measuring range		Range
Dec.	Hex.	$\pm 1$ V		
32767	7FFF	> 1.176 V		Overflow
32511	7EFF	1.176 V		Overrange
27649	6C01			
27648	6C00	1 V		Nominal range
20736	5100	0.75 V		
1	1	36.17 $\mu$ V		
0	0	0 V		
-1	FFFF			
-20736	AF00	-0.75 V		
-27648	9400	-1 V		
-27649	93FF			Underrange
-32512	8100	-1.176 V		
-32768	8000	<-1.176 V		Underflow

Table B-7 Voltage measuring range  $\pm 500$  mV to  $\pm 50$  mV

Values		Voltage measuring range			Range
Dec.	Hex.	$\pm 250$ mV	$\pm 80$ mV	$\pm 50$ mV	
32767	7FFF	> 294.0 mV	> 94.1 mV	> 58.8 mV	Overflow
32511	7EFF	294.0 mV	94.1 mV	58.8 mV	Overrange

Values		Voltage measuring range			Range
27649	6C01				Overrange
27648	6C00	250 mV	80 mV	50 mV	Nominal range
20736	5100	187.5 mV	60 mV	37.5 mA	
1	1	9.04 $\mu$ V	2.89 $\mu$ V	1.81 $\mu$ V	
0	0	0 mV	0 mV	0 mV	
-1	FFFF				
-20736	AF00	-187.5 mV	-60 mV	-37.5 mV	
-27648	9400	-250 mV	-80 mV	-50 mV	Underrange
-27649	93FF				
-32512	8100	-294.0 mV	-94.1 mV	-58.8 mV	Underflow
-32768	8000	<-294.0 mV	<-94.1 mV	<-58.8 mV	

## B.4 Representation of analog values for resistance-type sensors

The following tables list the decimal and hexadecimal values (codes) of the possible resistance-type sensors.

Table B-8 Resistance-type sensors from 150  $\Omega$  to 6000  $\Omega$

Values		Resistance-type sensor range					Range
Dec.	Hex.	150 $\Omega$	300 $\Omega$	600 $\Omega$	3000 $\Omega$	6000 $\Omega$	
32767	7FFF	> 176.38 $\Omega$	> 352.77 $\Omega$	> 705.53 $\Omega$	> 3527.7 $\Omega$	> 7055.3 $\Omega$	Overflow
32511	7EFF	176.38 $\Omega$	352.77 $\Omega$	705.53 $\Omega$	3527.7 $\Omega$	7055.3 $\Omega$	Overrange
27649	6C01						
27648	6C00	150 $\Omega$	300 $\Omega$	600 $\Omega$	3000 $\Omega$	6000 $\Omega$	Nominal range
20736	5100	112.5 $\Omega$	225 $\Omega$	450 $\Omega$	2250 $\Omega$	4500 $\Omega$	
1	1	5.43 m $\Omega$	10.85 m $\Omega$	21.70 m $\Omega$	108.5 m $\Omega$	217 m $\Omega$	
0	0	0 $\Omega$	0 $\Omega$	0 $\Omega$	0 $\Omega$	0 $\Omega$	
-32768	8000	(negative values are physically impossible)					Underflow <sup>1</sup>

<sup>1</sup> If the resistors are not connected correctly or the conductor resistance is too high

## B.5 Representation of analog values for thermal resistors

### NOTE

A higher resolution can be configured for the measuring range for the standard thermal resistors, see section Scalable measuring range (Page 36).

The tables below list the decimal and hexadecimal values (codes) of the thermal resistors.

Table B-9 Thermal resistor Pt 100, 200, 500, 1000 standard

Pt x00 standard in °C (1 digit = 0.1 °C)	Values		Pt x00 standard in °F (1 digit = 0.1 °F)	Values		Pt x00 standard in K (1 digit = 0.1 K)	Values		Range
	Dec.	Hex.		Dec.	Hex.		Dec.	Hex.	
> 1000.0	32767	7FFF	> 1832.0	32767	7FFF	> 1273.2	32767	7FFF	Overflow
1000.0	10000	2710	1832.0	18320	4790	1273.2	12732	31BC	Overrange
:	:	:	:	:	:	:	:	:	
850.1	8501	2135	1562.1	15621	3D05	1123.3	11233	2BE1	
850.0	8500	2134	1562.0	15620	3D04	1123.2	11232	2BE0	Nominal range
:	:	:	:	:	:	:	:	:	
-200.0	-2000	F830	-328.0	-3280	F330	73.2	732	2DC	
-200.1	-2001	F82F	-328.1	-3281	F32F	73.1	731	2DB	Underrange
:	:	:	:	:	:	:	:	:	
-243.0	-2430	F682	-405.4	-4054	F02A	30.2	302	12E	
< -243.0	-32768	8000	< -405.4	-32768	8000	< 30.2	32768	8000	Underflow

Table B-10 Thermal resistor Pt 100, 200, 500, 1000 climatic

Pt x00 climatic in °C (1 digit = 0.01 °C)	Values		Pt x00 climatic in °F (1 digit = 0.01 °F)	Values		Range
	Dec.	Hex.		Dec.	Hex.	
> 155.00	32767	7FFF	> 311.00	32767	7FFF	Overflow
155.00	15500	3C8C	311.00	31100	797C	Overrange
:	:	:	:	:	:	
130.01	13001	32C9	266.01	26601	67E9	
130.00	13000	32C8	266.00	26600	67E8	Nominal range
:	:	:	:	:	:	
-120.00	-12000	D120	-184.00	-18400	B820	
-120.01	-12001	D11F	-184.01	-18401	B81F	Underrange
:	:	:	:	:	:	
-145.00	-14500	C75C	-229.00	-22900	A68C	
< -145.00	-32768	8000	< -229.00	-32768	8000	Underflow

Table B-11 Thermal resistor Ni 100, 120, 200, 500, 1000, LG-Ni 1000 standard

Ni x00 standard in °C (1 digit = 0.1 °C)	Values		Ni x00 standard in °F (1 digit = 0.1 °F)	Values		Ni x00 standard in K (1 digit = 0.1 K)	Values		Range
	Dec.	Hex.		Dec.	Hex.		Dec.	Hex.	
> 295.0	32767	7FFF	> 563.0	32767	7FFF	> 568.2	32767	7FFF	Overflow
295.0 : 250.1	2950 : 2501	B86 : 9C5	563.0 : 482.1	5630 : 4821	15FE : 12D5	568.2 : 523.3	5682 : 5233	1632 : 1471	Overrange
250.0 : -60.0	2500 : -600	9C4 : FDA8	482.0 : -76.0	4820 : -760	12D4 : FD08	523.2 : 213.2	5232 : 2132	1470 : 854	Nominal range
-60.1 : -105.0	-601 : -1050	FDA7 : FBE6	-76.1 : -157.0	-761 : -1570	FD07 : F9DE	213.1 : 168.2	2131 : 1682	853 : 692	Underrange
< -105.0	-32768	8000	< -157.0	-32768	8000	< 168.2	32768	8000	Underflow

Table B-12 Thermal resistor Ni 100, 120, 200, 500, 1000, LG-Ni 1000 climatic

Ni x00 climatic in °C (1 digit = 0.01 °C)	Values		Ni x00 climatic in °F (1 digit = 0.01 °F)	Values		Range
	Dec.	Hex.		Dec.	Hex.	
> 295.00	32767	7FFF	> 327.66	32767	7FFF	Overflow
295.00 : 250.01	29500 : 25001	733C : 61A9	327.66 : 280.01	32766 : 28001	7FFE : 6D61	Overrange
250.00 : -60.00	25000 : -6000	61A8 : E890	280.00 : -76.00	28000 : -7600	6D60 : E250	Nominal range
-60.01 : -105.00	-6001 : -10500	E88F : D6FC	-76.01 : -157.00	-7601 : -15700	E24F : C2AC	Underrange
< - 105.00	-32768	8000	< - 157.00	-32768	8000	Underflow

## B.6 Representation of analog values for thermocouples

### NOTE

A higher resolution can be configured for thermocouples, see section Scalable measuring range (Page 36).

The tables below list the decimal and hexadecimal values (codes) of the thermocouples.

Table B-13 Thermocouple type B

Type B in °C	Values		Type B in °F	Values		Type B in K	Values		Range
	Dec.	Hex.		Dec.	Hex.		Dec.	Hex.	
> 2070.0	32767	7FFF	> 3276.6	32767	7FFF	> 2343.2	32767	7FFF	Overflow
2070.0	20700	50DC	3276.6	32766	7FFE	2343.2	23432	5B88	Overrange
:	:	:	:	:	:	:	:	:	
1820.1	18201	4719	2786.6	27866	6CDA	2093.3	20933	51C5	
1820.0	18200	4718	2786.5	27865	6CD9	2093.2	20932	51C4	Nominal range
:	:	:	:	:	:	:	:	:	
0.0	0	0000	32.0	320	0140	273.2	2732	0AAC	
-0.1	-1	FFFF	31.9	319	013F	273.1	2731	0AAB	Underrange
:	:	:	:	:	:	:	:	:	
-120.0	-1200	FB50	-184.0	-1840	F8D0	153.2	1532	05FC	
< -120.0	-32768	8000	< -184.0	-32768	8000	< 153.2	-32768	8000	Underflow

Table B-14 Thermocouple type C

Type C in °C	Values		Type C in °F	Values		Type C in K	Values		Range
	Dec.	Hex.		Dec.	Hex.		Dec.	Hex.	
> 2500.0	32767	7FFF	> 3276.6	32767	7FFF	> 2773.2	32767	7FFF	Overflow
2500.0	25000	61A8	3276.6	32766	7FFE	2773.2	27732	6C54	Overrange
:	:	:	:	:	:	:	:	:	
2315.1	23151	5A6F	2786.6	27866	6CDA	2588.3	25883	651B	
2315.0	23150	5A6E	2786.5	27865	6CD9	2588.2	25882	651A	Nominal range
:	:	:	:	:	:	:	:	:	
0.0	0	0000	32.0	320	0140	273.2	2732	0AAC	
-0.1	-1	FFFF	31.9	319	013F	273.1	2731	0AAB	Underrange
:	:	:	:	:	:	:	:	:	
-120.0	-1200	FB50	-184.0	-1840	F8D0	153.2	1532	05FC	
< -120.0	-32768	8000	< -184.0	-32768	8000	< 153.2	-32768	8000	Underflow

Table B-15 Thermocouple type E

Type E in °C	Values		Type E in °F	Values		Type E in K	Values		Range
	Dec.	Hex.		Dec.	Hex.		Dec.	Hex.	
> 1200.0	32767	7FFF	> 2192.0	32767	7FFF	> 1473.2	32767	7FFF	Overflow
1200.0	12000	2EE0	2192.0	21920	55A0	1473.2	14732	398C	Overrange
:	:	:	:	:	:	:	:	:	
1000.1	10001	2711	1832.1	18321	4791	1273.3	12733	31BD	
1000.0	10000	2710	1832.0	18320	4790	1273.2	12732	31BC	Nominal range
:	:	:	:	:	:	:	:	:	
-270.0	-2700	F574	-454.0	-4540	EE44	3.2	32	0020	
< -270.0	-32768	8000	< -454.0	-32768	8000	< 3.2	-32768	8000	Underflow

Table B-16 Thermocouple type J

Type J in °C	Values		Type J in °F	Values		Type J in K	Values		Range
	Dec.	Hex.		Dec.	Hex.		Dec.	Hex.	
> 1450.0	32767	7FFF	> 2642.0	32767	7FFF	> 1723.2	32767	7FFF	Overflow
1450.0	14500	38A4	2642.0	26420	6734	1723.2	17232	4350	Overrange
:	:	:	:	:	:	:	:	:	
1200.1	12001	2EE1	2192.1	21921	55A1	1473.3	14733	398D	
1200.0	12000	2EE0	2192.0	21920	55A0	1473.2	14732	398C	Nominal range
:	:	:	:	:	:	:	:	:	
-210.0	-2100	F7CC	-346.0	-3460	F27C	63.2	632	0278	
< -210.0	-32768	8000	< -346.0	-32768	8000	< 63.2	-32768	8000	Underflow

Table B-17 Thermocouple type K

Type K in °C	Values		Type K in °F	Values		Type K in K	Values		Range
	Dec.	Hex.		Dec.	Hex.		Dec.	Hex.	
> 1622.0	32767	7FFF	> 2951.6	32767	7FFF	> 1895.2	32767	7FFF	Overflow
1622.0	16220	3F5C	2951.6	29516	734C	1895.2	18952	4A08	Overrange
:	:	:	:	:	:	:	:	:	
1372.1	13721	3599	2501.7	25017	61B9	1645.3	16453	4045	
1372.0	13720	3598	2501.6	25016	61B8	1645.2	16452	4044	Nominal range
:	:	:	:	:	:	:	:	:	
-270.0	-2700	F574	-454.0	-4540	EE44	3.2	32	0020	
< -270.0	-32768	8000	< -454.0	-32768	8000	< 3.2	-32768	8000	Underflow

Table B-18 Thermocouple type L

Type L in °C	Values		Type L in °F	Values		Type L in K	Values		Range
	Dec.	Hex.		Dec.	Hex.		Dec.	Hex.	
> 1150.0	32767	7FFF	> 2102.0	32767	7FFF	> 1423.2	32767	7FFF	Overflow
1150.0	11500	2CEC	2102.0	21020	521C	1423.2	14232	3798	Overrange
:	:	:	:	:	:	:	:	:	
900.1	9001	2329	1652.1	16521	4089	1173.3	11733	2DD5	
900.0	9000	2328	1652.0	16520	4088	1173.2	11732	2DD4	Nominal range
:	:	:	:	:	:	:	:	:	
-200.0	-2000	F830	-328.0	-3280	F330	73.2	732	02DC	
< -200.0	-32768	8000	< -328.0	-32768	8000	< 73.2	-32768	8000	Underflow

Representation of analog values

B.6 Representation of analog values for thermocouples

Table B-19 Thermocouple type N

Type N in °C	Values		Type N in °F	Values		Type N in K	Values		Range
	Dec.	Hex.		Dec.	Hex.		Dec.	Hex.	
> 1550.0	32767	7FFF	> 2822.0	32767	7FFF	> 1823.2	32767	7FFF	Overflow
1550.0	15500	3C8C	2822.0	28220	6E3C	1823.2	18232	4738	Overrange
:	:	:	:	:	:	:	:	:	
1300.1	13001	32C9	2372.1	23721	5CA9	1573.3	15733	3D75	
1300.0	13000	32C8	2372.0	23720	5CA8	1573.2	15732	3D74	Nominal range
:	:	:	:	:	:	:	:	:	
-270.0	-2700	F574	-454.0	-4540	EE44	3.2	32	0020	
< -270.0	-32768	8000	< -454.0	-32768	8000	< 3.2	-32768	8000	Underflow

Table B-20 Thermocouples R and S

Types R, S in °C	Values		Types R, S in °F	Values		Types R, S in K	Values		Range
	Dec.	Hex.		Dec.	Hex.		Dec.	Hex.	
> 2019.0	32767	7FFF	> 3276.6	32767	7FFF	> 2292.2	32767	7FFF	Overflow
2019.0	20190	4EDE	3276.6	32766	7FFE	2292.2	22922	598A	Overrange
:	:	:	:	:	:	:	:	:	
1769.1	17691	451B	3216.3	32163	7DA3	2042.3	20423	4FC7	
1769.0	17690	451A	3216.2	32162	7DA2	2042.2	20422	4FC6	Nominal range
:	:	:	:	:	:	:	:	:	
-50.0	-500	FE0C	-58.0	-580	FDBC	223.2	2232	08B8	
-50.1	-501	FE0B	-58.1	-581	FDBB	223.1	2231	08B7	Underrange
:	:	:	:	:	:	:	:	:	
-170.0	-1700	F95C	-274.0	-2740	F54C	103.2	1032	0408	
< -170.0	-32768	8000	< -274.0	-32768	8000	< 103.2	< 1032	8000	Underflow

Table B-21 Thermocouple type T

Type T in °C	Values		Type T in °F	Values		Type T in K	Values		Range
	Dec.	Hex.		Dec.	Hex.		Dec.	Hex.	
> 540.0	32767	7FFF	> 1004.0	32767	7FFF	> 813.2	32767	7FFF	Overflow
540.0	5400	1518	1004.0	10040	2738	813.2	8132	1FC4	Overrange
:	:	:	:	:	:	:	:	:	
400.1	4001	0FA1	752.1	7521	1D61	673.3	6733	1AAD	
400.0	4000	0FA0	752.0	7520	1D60	673.2	6732	1AAC	Nominal range
:	:	:	:	:	:	:	:	:	
-270.0	-2700	F574	-454.0	-4540	EE44	3.2	32	0020	
< -270.0	-32768	8000	< -454.0	-32768	8000	< 3.2	-32768	8000	Underflow

Table B-22 Thermocouple type U

Type U in °C	Values		Type U in °F	Values		Type U in K	Values		Range
	Dec.	Hex.		Dec.	Hex.		Dec.	Hex.	
> 850.0	32767	7FFF	> 1562.0	32767	7FFF	> 1123.2	32767	7FFF	Overflow
850.0 : 600.1	8500 : 6001	2134 : 1771	1562.0 : 1112.1	15620 : 11121	2738.0 : 2B71	1123.2 : 873.3	11232 : 8733	2BE0 : 221D	Overrange
600.0 : -200.0	6000 : -2000	1770 : F830	1112.0 : -328.0	11120 : -3280	2B70 : F330	873.2 : 73.2	8732 : 732	221C : 02DC	Nominal range
< -200.0	-32768	8000	< -328.0	-32768	8000	< 73.2	-32768	8000	Underflow

Table B-23 Thermocouple type TXK (GOST)

Type TXK in °C	Values		Type TXK in °F	Values		Type TXK in K	Values		Range
	Dec.	Hex.		Dec.	Hex.		Dec.	Hex.	
> 1050.0	32767	7FFF	> 1922.0	32767	7FFF	>1323.2	32767	7FFF	Overflow
1050.0 : 800.1	10500 : 8001	2904 : 1F41	1922.0 : 1472.1	19220 : 14721	4B14 : 3981	1323.2 : 1073.3	13232 : 10733	33B0 : 29ED	Overrange
800.0 : 0.0 : -200.0	8000 : 0 : -2000	1F40 : 0000 : F830	1472.0 : 32.0 : -328.0	14720 : 320 : -3280	3980 : 0140 : F330	1073.2 : 273 : 73.2	10732 : 2730 : 732	29EC : 0AAA : 02DC	Nominal range
< -200.0	-32768	8000	< -328.0	-32768	8000	<73.2	-32768	8000	Underflow